

GoldStar

MODEL OS-7020

OSCILLOSCOPE

SERVICE MANUAL

GoldStar

MODEL OS-7020

OSCILLOSCOPE

SERVICE MANUAL

 **GoldStar Precision Co., Ltd.**

CONTENTS

	Page
1. General -----	1
2. Specifications -----	2
3. Accessories -----	5
4. External View -----	7
5. Preventive Maintenance -----	9
5-1 Cleaning -----	9
5-2 Visual inspection -----	10
5-3 Periodical calibration -----	10
6. Measuring instruction -----	11
6-1 Probe phase adjustment -----	11
6-2 Voltage measurement -----	12
6-3 Frequency measurement -----	14
6-4 Rise(fall) time measurement -----	15
6-5 Pulse width measurement -----	16
6-6 Phase measurement -----	16
7. Circuit description -----	18
8. Calibration -----	21
8-1 Period of check and calibration -----	21
8-2 Test equipment required -----	21
8-3 Preliminary procedure -----	21
8-4 Preliminary control settings -----	23
8-5 Initial starting procedure -----	23
9. Semiconductor lead configurations -----	34
10. Electrical parts list -----	35
(1) ATTENUATOR -----	35
(2) CH1 INPUT AMP -----	36

(3) CH2 INPUT AMP.-----	39
(4) VERTICAL CONTROL -----	42
(5) VERTICAL MAIN AMP. -----	44
(6) TRIGGER AMP. -----	46
(7) SWEEP GENERATOR -----	47
(8) TIMING CIRCUIT -----	49
(9) HORIZONTAL MAIN AMP. -----	50
(10) CHOP PULSE GENERATOR -----	52
(11) HIGH VOLT & CRT DRIVE -----	53
(12) POWER SUPPLY -----	55
(13) PANEL & OTHERS -----	57
11. Electrical Parts arrangement -----	59
(with Adjustment Location)	
12. Block diagram -----	62
13. Schematic diagrams -----	63
14. Wiring diagram -----	75
15. Mechanical parts List and exploded view -	77

NOTICE

This Service Manual describes the most typical product of this model. If there are any specific differences between this Manual and the servicing unit, please contact GoldStar Precision sales office in your area.

1. General

The OS-7020 is a compact-type and advanced class oscilloscope which covers a frequency bandwidth from DC to 20MHz

- 1) CRT(Cathode-Ray Tube) has a viewing area 8x10 div and high intensity quantitative measurement is possible by means of the stable accelerating potential of 2KV.
- 2) Vertical deflection factor is from 5mV/div to 5V/div in a 1-2-5 sequence. x5 Magnifier increases sensitivity of each deflection.
- 3) Horizontal deflection system provides sweep rates from 0.2 μ S/div to 0.2S/div in a 1-2-5 sequence. 10 times sweep magnification and X-Y operation for Lissajou's pattern.
- 4) The Trigger system provides an internal triggering, external triggering and TV-triggering.

2. SPECIFICATIONS

CRT(Cathode-Ray Tube)

Type

6" screen with internal graticule parallax free acceleration
potential : Approximately 2KV

Phosphor

P31(standard)

Useful screen area

8x10div(1 div= 10mm)

Trace Rotation Provided

Intensity Control Provided

Focus Control Possible

Scale illumination Variable

Vertical Deflection system

Frequency Response & Rise Time

DC to 20MHZ(-3dB) and 17.5nS or less

DC to at least 7MHZ and 50nS or less at x5 Magnifier extends

AC coupled lower(-3dB) frequency is 10HZ or less

Deflection factor

VARIABLE is pushed(x1)

5mV/div to 5V/div in 10 calibrated steps in a 1-2-5

sequence(accuracy $\pm 3\%$, 10°C - 35°C)

VARIABLE is pulled(PULL x 5MAG)

The uncalibrated continuous control extends deflection factor

from 1mV/div to at least 12.5V/div in the 5V/div

position(accuracy $\pm 5\%$, 10°C - 35°C)

Display mode

CH1(normal or add), CH2(normal or invert), Alternate, chopped
(approximate 250KHZ)

Input impedance

1Mohm in parallel with 20pF(+2pF)

Maximum input voltage

300V(DC + peak AC) or 500Vp-p AC(1KHz or less)

Input coupling

AC - GND - DC

Horizontal Deflection system

Sweep rate

0.2 μ s/div to 0.2s/div in 19 calibrated steps in a 1-2-5 sequence. Uncalibrated continuous control extends deflection factor to at least 0.5 seconds per division in the 0.2s/div position(accuracy \pm 3%, 10 $^{\circ}$ C - 35 $^{\circ}$ C)
x10MAG extends maximum sweep rate to 20ns/div(accuracy \pm 5%, 10 $^{\circ}$ C - 35 $^{\circ}$ C)

Triggering system

MODE

Automatic, Normal, TV-V, TV-H

SOURCE

CH1, CH2, LINE, External

COUPLING

AC : 25HZ to full bandwidth

HF Rejection : use signal below 15KHz

LF Rejection : use signal over 15KHz

DC : DC to full bandwidth

HOLD OFF

Variable

Slope

+ or -

TV sync polarity

TV(-)

Sensitivity and frequency

	20HZ - 2MHZ	2MHZ - 20MHZ
INT	0.5div	1.5div
EXT	200mV	800mV

TV-V Sensitivity

Trigger level is 1 division or more with displayed amplitude of sync signal portion of composite signal.

External trigger input impedance

1Mohm in parallel with 20pF(+2pF)

maximum input voltage

300V(DC + peak AC) or 500Vp-p AC(1KHz or less)

X-Y Operation

CH1 : Horizontal

CH2 : Vertical

Deflection factor

same as vertical deflection

Accuracy

X ; $\pm 3\%$ (10°C - 35°C)

Y ; $\pm 3\%$ (10°C - 35°C)

Additional error for magnifier $\pm 2\%$

X-bandwidth

DC to at least 500KHZ

Phase error

3° or less from DC to 20KHZ

Z-AXIS input

Positive-going signal decrease intensity 5Vp-p

noticeable modulation at normal intensity for DC-2MHz

Input impedance 47Kohm

Maximum input voltage 30V(DC + peak AC)

coupling DC

Calibrator

Approximate 1KHz frequency 0.5V($\pm 3\%$) square wave.

CH1 Signal output

Output voltage is at least 20mV/div into a 50ohm Load.

Bandwidth is 50Hz to at least 4MHz.

Power supply

Votlage(50/60HZ)	Fuse
100V(90-110V)	2A
120V(108-132V)	2A
220V(198-242V)	1A
240V(216-264V)	1A

Power supply frequency 50,60,400Hz

Power consumption Approx. 35W

Environment

Limit of operation temperature	0-40°C(32-104°F)
Limit of operation humidity	35-85%
Rated range of use temperature	10-35°C (50-95°F)
Rated range of use humidity	45-85%
Storage and transport temperature	-20-70°C(-4 - 158°F)

Dimension and weight

Approx. 290(W) x 145(H) x 375(D)mm
(11.6(W) x 5.8(H) x 15(D) inches)
Approx. 8.0Kg(17.6Ibs)

3. ACCESSORIES

This instrument is shipped along with following accessories

FUSE	1
AC power cord	1
Operation manual	1

4. EXTERNAL VIEW

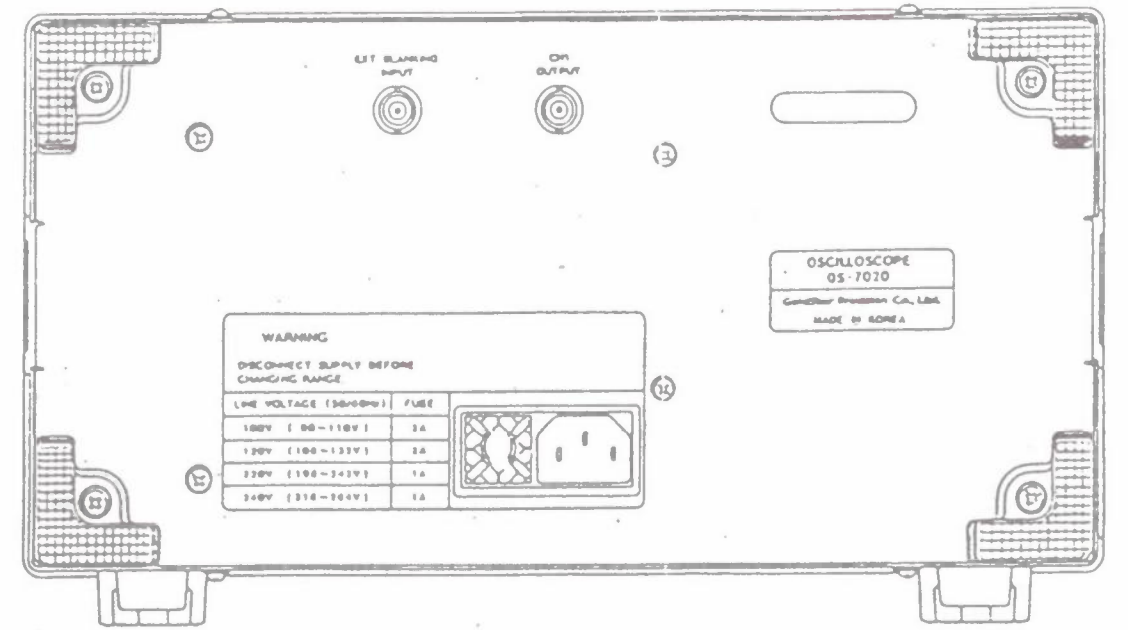
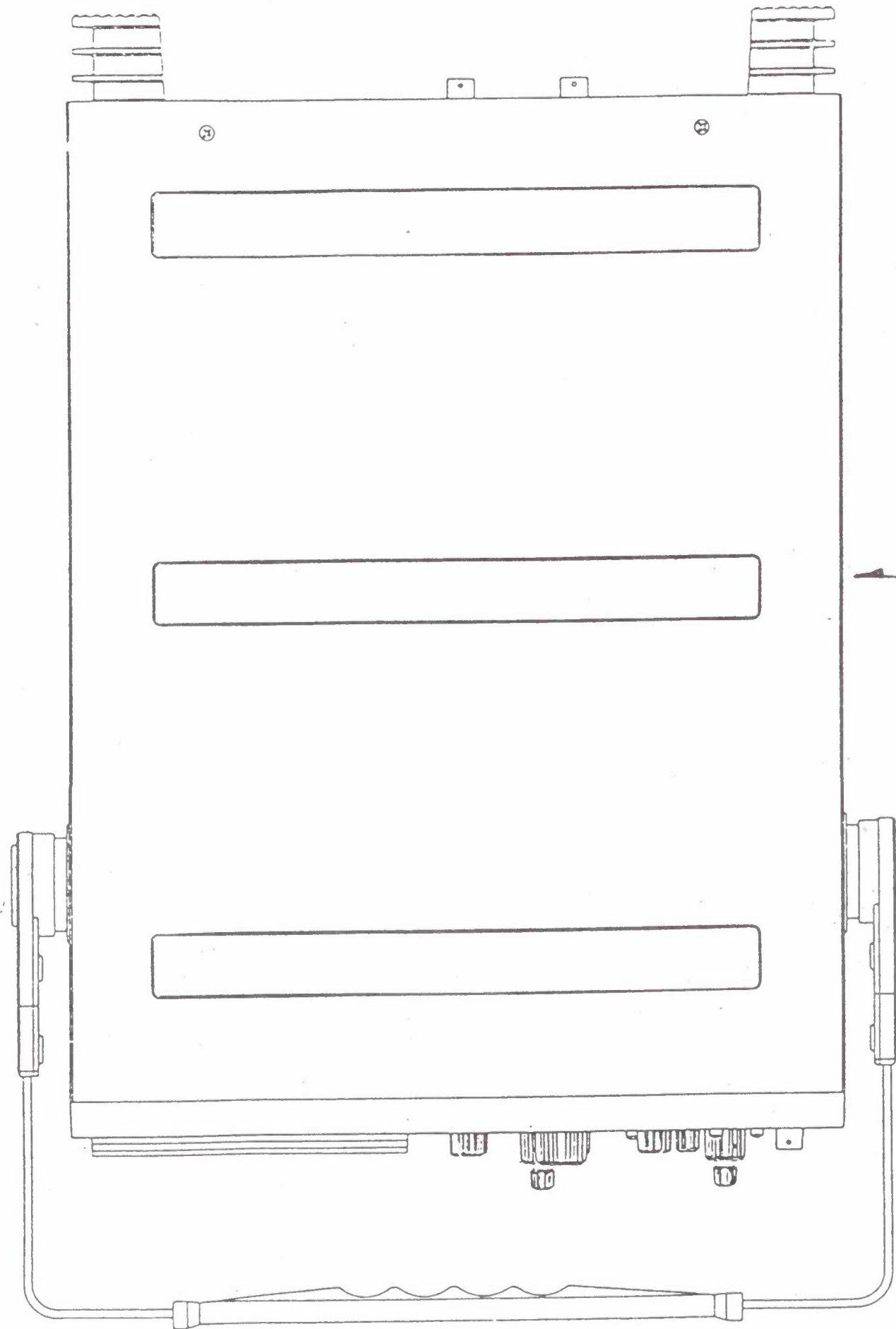

REAR VIEW

FRONT VIEW

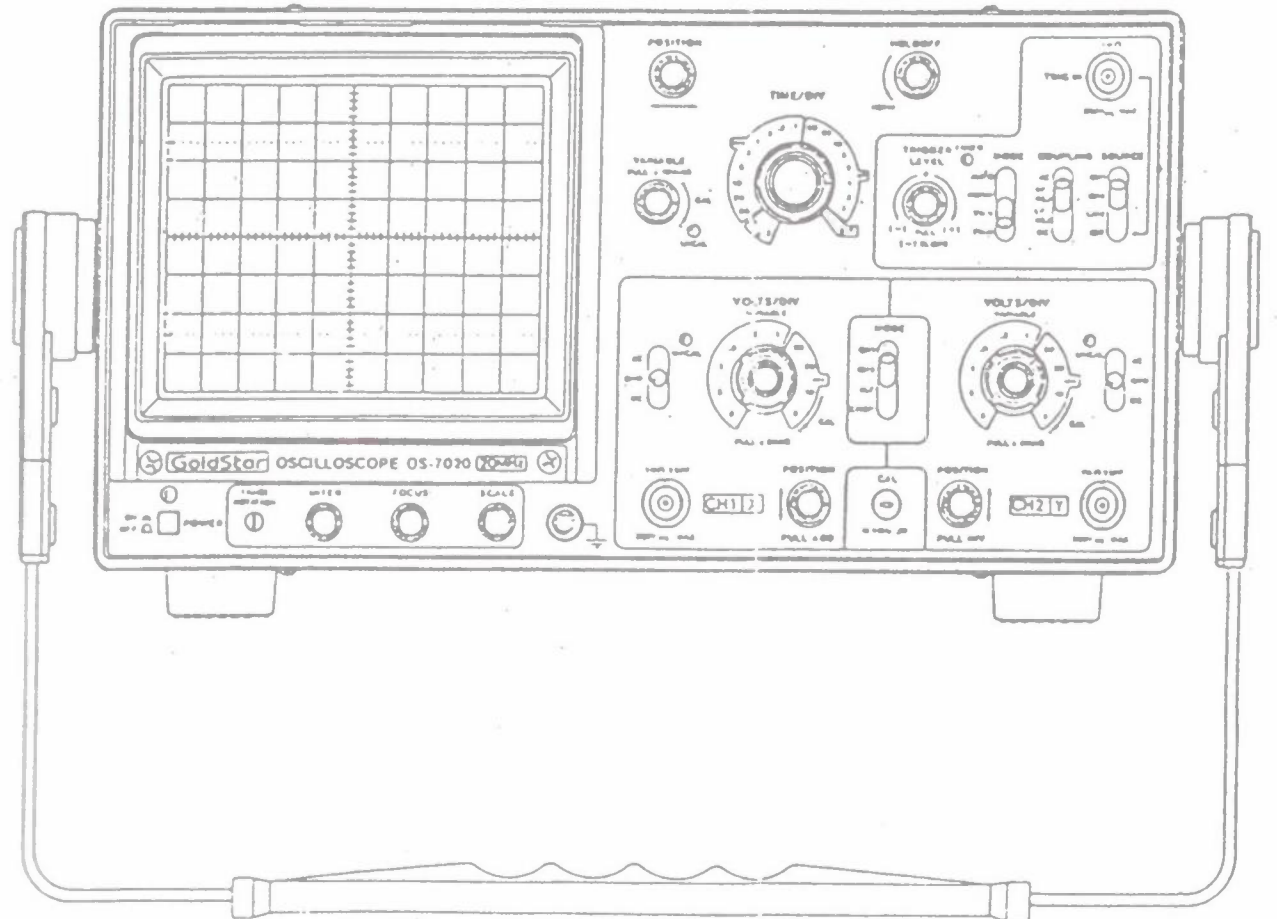

5. PREVENTIVE MAINTENANCE

These are the precautions on preventive maintenance which will protect the instrument from trouble and keep it clean for a long time.

5-1 Cleaning

Since the extent of instrument smearing depends on the ambient condition in which the oscilloscope is used, the frequency of the cleaning operations cannot be defined initially.

Cleaning should be accomplished as required.

Dust deposited inside the instrument affects the normal flow of cooling air and invites the local overheating of components parts of results in trouble.

Smearred switch contacts of connector pins can be the cause of defective contact, and smearing of the circuit can cause arcing between circuits, particularly in moist season.

Cleaning agents recommended and those prohibited are listed as below.

Recommended agent	Alcohol, gasoline or keroscene
Prohibited agent	Acetone, tri-ethyl-ketone lacquer thinner or agent containing ketone series solvent

Cleaning the cover

Normal smearing of the cover can be cleaned by washing the cover with a neutral chemical cleaner. For greasy smearing, use a recommended agent with a soft cloth.

Front and other panels.

Clean the smearred panel with a soft cloth moistened with a recommended agent.

Dust in-instrument

The best way to remove dust inside the instrument is the blowing of compressed air. Remove persistent dust with a soft painting brush and blow the air again.

CRT

The CRT screen will be smeared if it is used for too long without the filter. Ordinary dust or finger print left on the CRT can be cleaned by a soft cloth. Use a soft cloth moisted with alcohol to remove persistent smearing.

Filter

The filter may be clogged when used for a long time.

Dust or fingerprint can be cleaned with a dry soft cloth.

Use a soft cloth moisted with alcohol to remove persistent smearing.

5-2 Visual inspection

The instrument should be inspected occasionally for such defects as broken connections, improperly seated transistors, damaged circuit boards, and heat-damaged parts. The corrective procedure for most visible defects is apparent ; however, particular care must be taken if heat-damaged components are found.

Overheating usually indicates other trouble in the instrument; therefore, correcting the cause of the overheating is important to prevent the recurrence of the damage.

5-3 Periodical Calibration

In order to use the oscilloscope accurately, periodical calibration of circuit is essential. When this oscilloscope is used frequently, a calibration will be required at every 1,000hours of operation.

The frequency of calibration may be extended to 6 months, if the oscilloscope is used infrequently.

6. MEASURING INSTRUCTION

6-1 Probe phase Adjustment

Proper adjustment of the probe phasing is required before measurements as the incorrect phasing results in erroneous measurements when the $\times 10$ position is selected.

1. Set the controls as follows ;

VOLTS/DIV 0.1V

VARIABLE CAL

TIME/DIV 0.5ms

(sweep)VARIABLE CAL

(Horizontal)POSITION CENTER

2. Set the probe switch to $\times 10$ and connect the probe between the input connector and the CAL OUT terminal.

3. Display the calibration voltage waveform with 5 divisions amplitude

4. Adjust the variable capacitor of the probe using the small driver, and set the top of the waveform to the correct phasing shown in Fig. 6-1

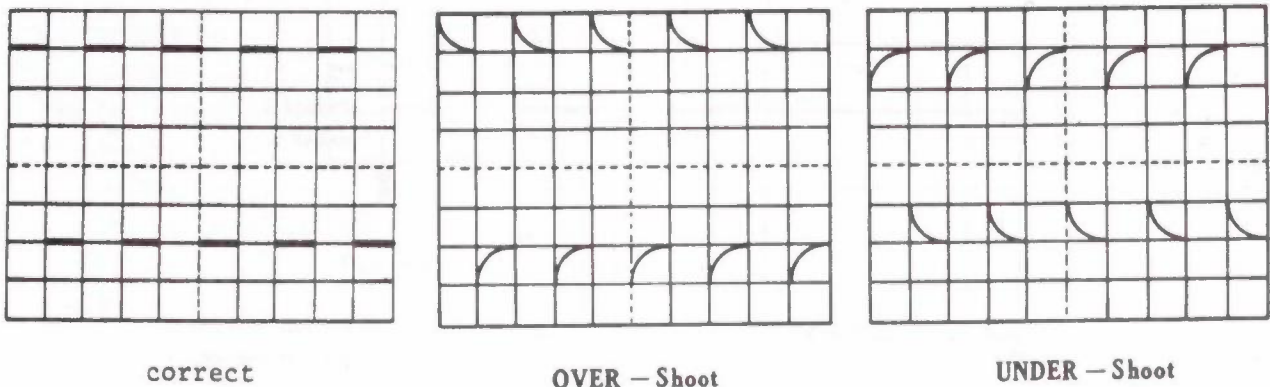

Fig 6-1. Phasing of probe & Waveform

6-2 Voltage measurement

6-2-1 DC Voltage Measurement

1. Set the AC-GND-DC switch to GND. The vertical position of the trace in this case is used as 0-volt reference line as shown in Fig. 6-2. Adjust the vertical position control in order to place the trace exactly on a horizontal graticule, which facilitates the reading of signal voltage.

2. Set the trigger MODE switch to AUTO.

Select a sweep rate so that the trace may not flicker.

3. Set the AC-GND-DC switch to DC, and apply the voltage to be measured to the input connector. The vertical displacement of the trace gives the voltage amplitude of the signal. When the trace shifts upward, the measured voltage is positive with regard to the ground potential when the trace shifts downward, the voltage is negative.

The voltage can be obtained by Equation(1) or (2).

- a. Measurement with the x1 position of the probe

$$\text{Voltage(V)} = \text{VOLTS/DIV setting value(V/div)} \\ \times \text{Displayed amplitude of input} \\ \text{signal(div)} \text{ ----- (1)}$$

- b. Measurement with the X10 position of the probe

$$\text{Voltage(V)} = \text{VOLTS/DIV setting value(V/div)} \\ \times \text{Displayed amplitude of input} \\ \text{signal(div)} \times 10 \text{ -----(2)}$$

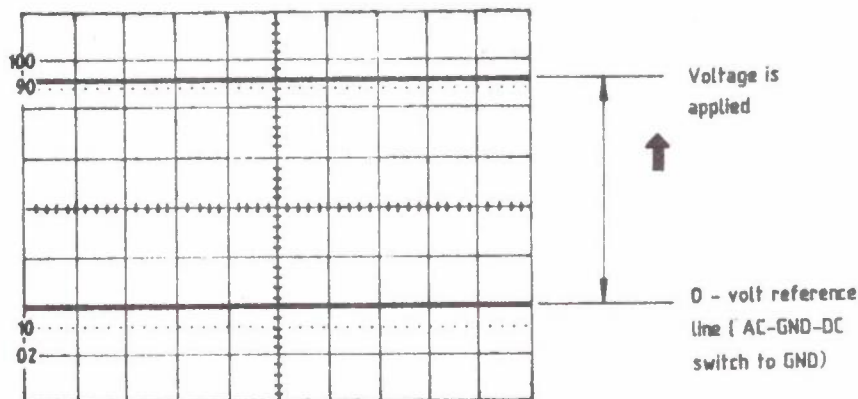

Fig 6-2. DC Voltage measurement

6-2-2 AC voltage measurement

The measurement of the voltage waveform is performed as follows ; Set the VOLTS/DIV switch in order to obtain the amplitude for easy reading, read the amplitude as shown in Fig. 6-3 and calculate by equation(1) or (2).

When the waveform superimposed on DC current is measured, set the AC-GND-DC switch to DC in order to measure the value including DC component, or set this switch to AC in order to measure AC component only.

The measured value by means of this procedure is peak value(V_{p-p}). Effective value(V_{rms}) of a sine wave signal can be given by Equation(3).

$$\text{Effective voltage}(V_{rms}) = \frac{\text{Peak voltage}(V_{p-p})}{2\sqrt{2}} \quad \text{--- (3)}$$

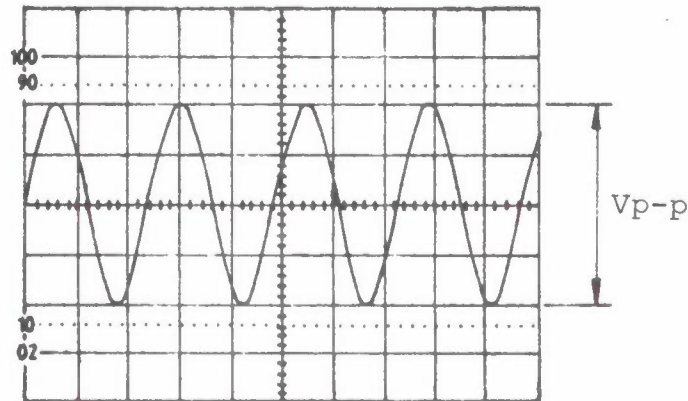

Fig 6-3. AC Voltage measurement

6-3 Frequency measurement

The first method ; Calculate the one cycle time(interval) of the input signal and obtain the frequency by equation(4)

$$\text{Frequency(Hz)} = \frac{1 \text{ (C)}}{\text{PERIOD(S)}} \quad \text{----- (4)}$$

The second method ; Count the repetition number N per 10 divisions in the viewing area, and calculate the frequency by Equation (5)

$$\text{Frequency(Hz)} = \frac{N(C)}{\text{TIME/DIV setting value(s/div) \times 10(div)}} \quad (5)$$

When N is large(30-50), the second method can give a high accuracy level than that obtained with the first method. This accuracy is approximately equal to the rated accuracy of sweep rate. However, when N is small, the count below decimal point becomes very ambiguous, which results in considerable error.

For the measurement of comparatively low frequencies having a simple pattern such as sine wave, square wave, triangle wave, and sawtooth wave, measurement with high accuracy can be effected by the following method ; Operate the oscilloscope as an X-Y scope, make the Lissajou's pattern by applying the signal of which frequency is known, and read the necessary value.

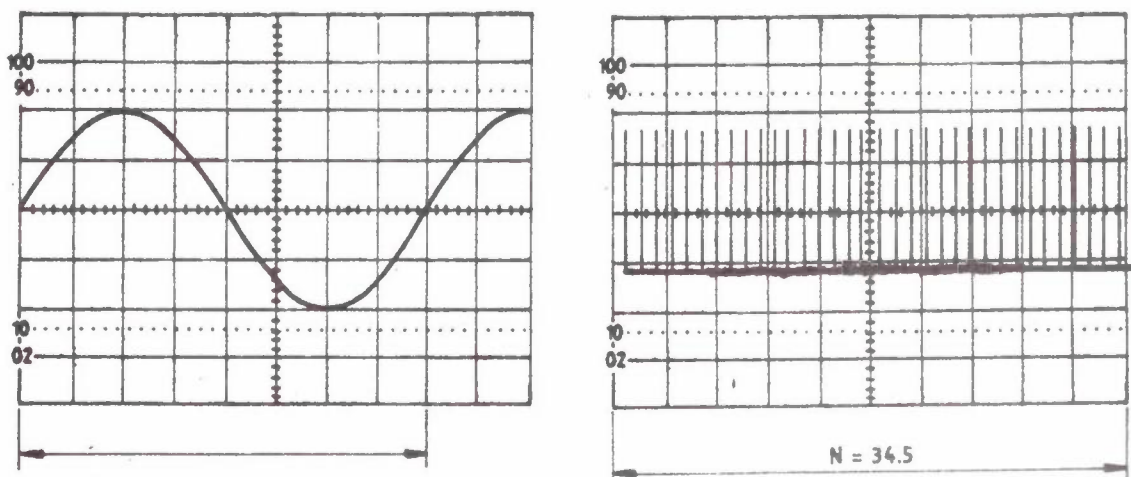

Fig 6-4. Frequency measurement

6-4 Rise(Fall) time measurement

1. Display the pulse waveform vertically and horizontally in the same manner as for the pulsewidth measurement procedure.
2. Turn the horizontal POSITION control in order to set the upper 10% point of the waveform on the vertical center line of the graticule. Read the distance T1 between the vertical center line and the point at which the rising (falling) edge crosses the horizontal center line.
3. Shift and set the lower 10% point of the waveform to the vertical center line of the graticule as shown by the dotted line in Fig 6-5. Read the distance T2 between the vertical center line and the point at which the rising (or falling) edge crosses the horizontal center line.
4. Calculate the rise(or fall) time by substituting the sum of T1 and T2

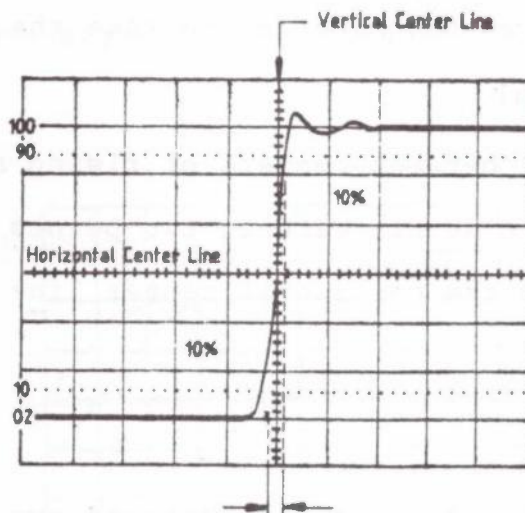

Fig 6-5 Rise(or fall) time measurement

6-5 Pulsewidth Measurement

The basic pulsewidth measurement procedure is as follows ;

1. Display the pulse waveform vertically so that the distance between the top part of the pulse waveform and the horizontal center line of the graticule may be equal to the distance between the bottom part of the pulse and the horizontal center line as shown in Fig. 6-6

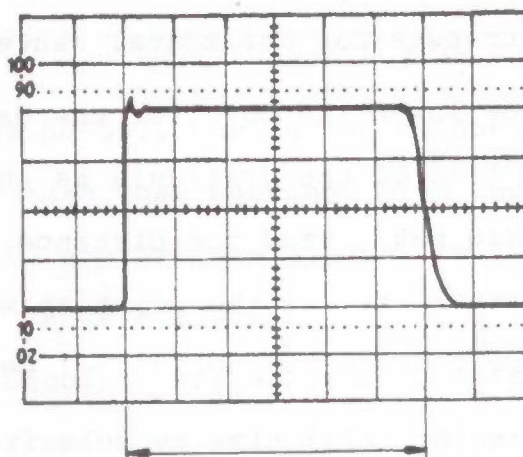

Fig 6-6 Pulsewidth measurement

2. Set the TIME/DIV switch in order to make the easy observation of the signal.
3. Read the distance between centers of rising and falling edges, i.e., the distance between two points at which pulse edges cross the horizontal center line of the graticule.

6-6 Phase Measurement

The measurement of phase difference between two signals, there are the following two methods ;

The first one is the Lissajou's pattern method by using the instrument as an X-Y scope. The phase difference of

signals can be calculated from the amplitude A and B of the pattern shown in Fig 6-7 and by Equation(6)

$$\text{Phase difference(deg)} = \sin^{-1} \frac{A}{B} \quad \text{----- (6)}$$

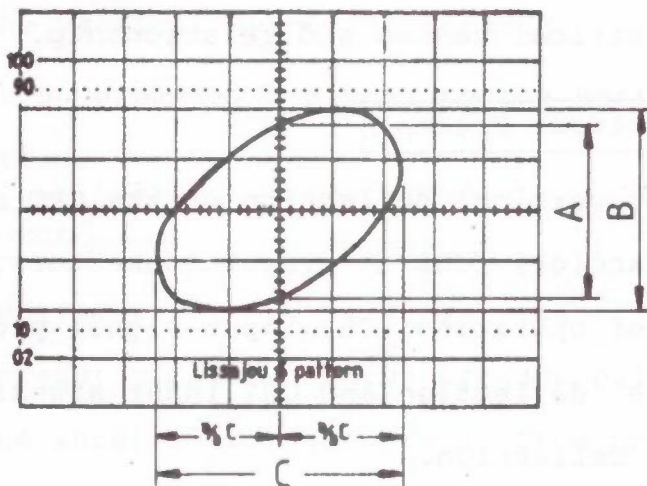

Fig 6-7 Phase difference measurement using X-Y operation

The second method is an application of dual-trace function

Fig 6-8 shows an example of dual-trace display of leading and lagging sine wave signals having the same frequency.

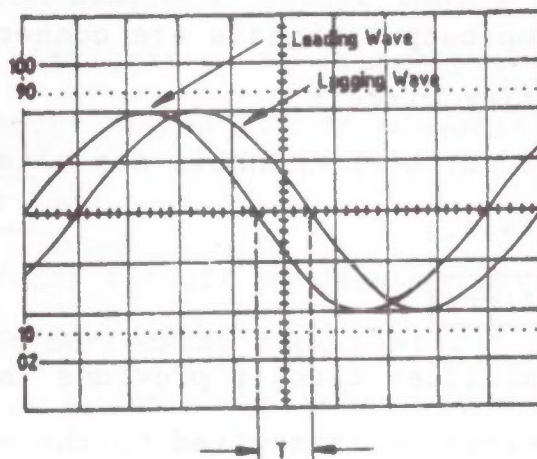

Fig 6-8 Phase difference measurement by dual-trace display

7. CIRCUIT DESCRIPTION

The block diagram (page 62) shows the overall relationship between all of the circuits. Complete schematics of each circuit are also given in section schematic diagrams (page 63-to 75)

Refer to these diagrams throughout the following circuit description for electrical values and relationship.

Channel 1 & 2 Vertical Preamp

Input signals for vertical deflection on the CRT can be connected to the "CH1 X" and (or) "CH2 Y" input connectors.

In the X-Y mode of operation, CH1 input signal provides the horizontal (X-axis) deflection and CH2 input signal provides the vertical (Y-axis) deflection.

The Channel 1 and 2 Vertical Preamp circuits provide control of input coupling, vertical deflection factor, DC balance, Vertical position and vertical gain.

They also contain a stage to provide a sample of the input signal to the Trigger Preamp circuit for internal triggering from the Channel 1 and (or) Channel 2 signal only.

Vertical switching circuit

The vertical switching circuit determines whether the CH1 or CH2 or both Vertical Preamp output signals are connected to the Vertical Output Amplifier circuit.

In the ALT and CHOP modes, both channels are alternately displayed on a shared time basis.

Vertical Output Amplifier

The Vertical Output Amplifier circuit provides the final amplification for the signal before it is applied to the vertical deflection plates of the CRT.

Trigger Preamp

The Trigger Preamp circuit amplifies the internal trigger signal to the level necessary to drive the Trigger Generator circuit. Input signal for the Trigger Preamp circuit is obtained by sampling the signal applied to channel 1 or the composite vertical signal from the Vertical Switching circuit.

This circuit also provides a signal to the Horizontal Amplifier for X-Y operation.

Trigger Generator

The Trigger Generator circuit produces trigger pulses to start the Sweep Generator circuit. These trigger pulses are derived either from the internal trigger signal from the vertical deflection system, an external signal connected to the external TRIG Input connector or a sample of the line voltage applied to the instrument.

Controls are provided in this circuit to select trigger level, slope and source. The trigger MODE switch determines the operating mode for the trigger circuit. In the NORM position, a sweep is produced only when a trigger pulse is received from the Trigger Generator circuit. Operation in the AUTO position is the same mode as NORM position, except that a free-running trace is displayed when a trigger pulse is not present or when the amplitude of the trigger signal is not adequate.

Sweep Generator

The Sweep Generator circuit produces a sawtooth voltage which is amplified by the Horizontal Amplifier circuit to provide horizontal deflection on the CRT. This sawtooth voltage is generated on command(trigger pulse) from the Trigger Generator circuit.

The Sweep Generator circuit also produces an unblanking gate to unblank the CRT during sweep time.

Horizontal Amplifier

The Horizontal Amplifier circuit provides the output signal to the CRT horizontal deflection plates. In all positions of the TIME/DIV select switch except X-Y, the horizontal deflection signal is a sawtooth from the Sweep Generator circuit. In the X-Y position, the horizontal deflection signal is obtained from the Channel 1 Vertical Preamp through the Trigger Preamp circuit. In addition, the horizontal amplifier contains the horizontal magnifier and the horizontal positioning circuits.

Power Supply

The low-voltage Power Supply circuit provides the operation power for this instrument from five regulated supplies and one unregulated supply. The Power Input stage is provided with a Voltage Selector Assembly. This selector allows selection of the nominal operating voltage and regulating range for the instrument.

Calibrator

The Calibrator circuit produces a square-wave output with accurate amplitude and frequency. This output is available as a squarewave voltage at the CAL 0.5V(1KHz) connector.

The effect of these input signals is to either increase or decrease the trace intensity, or to completely blank portions of the display.

CRT Circuit

The CRT Circuit provides the high-voltage and control circuits necessary for operation of the Cathod-Ray Tube (CRT).

TEST EQUIPMENT REQUIRED

Description	Minimum specification	Usage	Example of applicable test equipment
1. Constant amplitude signal generator	50kHz reference frequency; maximum frequency 70MHz; variable amplitude	Check horizontal, vertical and trigger bandwidth.	
2. Standard amplitude calibrator	Amplitude accuracy: 0.25%, variable amplitude; 5mV to 40V; frequency: 1 kHz square wave	Check horizontal and vertical gain.	
3. Square-wave generator	Variable frequency: 10Hz to 1MHz; output amplitude; 10mV to 100V	Check probe and vertical compensation.	
4. Digital voltmeter	0.1% accuracy	Check power supply.	
5. Time mark generator	0.1% accuracy	Check horizontal timing.	
6. Cable	Impedance, 50 ohms; type, RG-58/U; length, 42 inches, connectors, BNC	External trigger operation check. Horizontal gain check and adjustment.	
7. Termination	Impedance, 50 ohms; connectors, BNC	Vertical amplifier compensation checks and adjustment.	
8. Attenuator	Ratio, 1/10; connectors, BNC; impedance, 50 ohms	Vertical amplifier bandwidth check.	
9. T-connector	Connectors, BNC	External trigger operation checks.	

8-4. Preliminary control settings

Set the instrument controls as follows, when starting the calibration procedures.

Controls	Settings	Controls	Settings
FOCUS	Midrange	SWP VAR	Fully clockwise
TRACE ROTATION	As desired		
- VERT -			
V. POSITION	Midrange, pushed in		
V. VARIABLE	CAL, fully clockwise		
INPUT COUPLING	GND (AC-GND-DC)	- TRIG -	
VOLTS/DIV	5 mV/DIV	TRIG. COUPLE	AC
V.MODE	CH1	LEVEL	Midrange, Normal
CH2 INV	Normal, Pushed in	SLOPE	+ Normal
- HORZ -			
H. POSITION	Midrange	MODE	AUTO
PULL x10 MAG	Normal, Pushed in		
TIME/DIV	1 ms	TRIG. SOURCE	CH1

8-5. Initial starting procedure.

1. Rotate the INTENSITY control to the midrange and set the POWER switch to ON.
2. Wait a few seconds for the cathode ray tube (CRT) to warm up. A trace should appear on the CRT.
3. If trace disappears, increase (clockwise) the INTENSITY control setting until the trace is easily observed, or roughly check/adjust the DC balance to get a trace as same as ②.
4. Adjust the FOCUS control for the best focused display.
5. Readjust the POSITION controls if necessary, to center the trace.

Power Supply System

* NOTE : Before you start operation, see the adjustment locations in the pullout pages.

Control setting

Preset the controls as given in the preliminary control setting.

- ① Check low voltage supply, if necessary.
 - a. Connect the digital voltmeter(DVM) between the +12V line (P810-4) and ground.
; +11.7 to +12.3V
 - b. Connect the DVM between the -12V Line(P810 -2) and ground.
; -12.3 to -11.7V
 - c. Connect the DVM between the +5V line(P810 -3) and ground.
; +4.8 to 5.2V
 - d. Connect the DVM between the +51V line(P810 -5) and ground.
; +50.5 to 51.5V
 - i) Conect THE PROB(10x1) with X+(R674) and X-(R663) on the horizontal board.
 - ii) Set O'SCOPE VOLT/DIV to 5V. RANGE and also, the lines of wave form of CH1 and CH2 must be coincided with Ref Line.

NOTE ; Ref to figure as following.
 - iii) Set the H-POSITION to the left side.
 - iv) Adjust VR805 as following ;

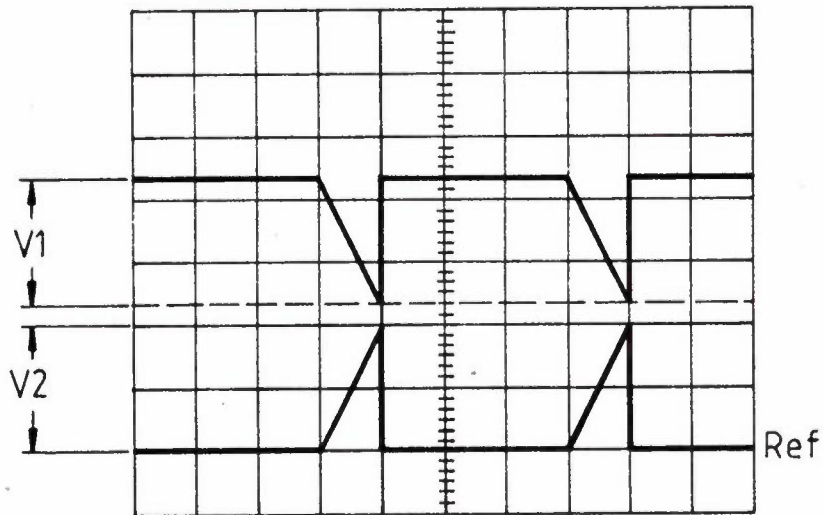

$$(V1 = V2)$$

V1 MUST BE SAME AS V2

- e. Connect the DVM between the +160V line(P810 -6) and ground.
; +150 to +170V
 - f. Connect the DVM between the +180V line(P810 -7) and ground.
; +170 to 190V
 - g. Connect the DVM between the +18V line(P804-1) and ground.
; +17 to +19V
2. Check high voltage supply
- a. Connect the DVM between the H.V.(P612-6) and ground with a high voltage probe.
 - b. Check for a reading of -1, 995 to -1, 805V

DISPLAY

Control setting

Preset the controls as given in the preliminary control setting.

③ Check/adjust INTEN ADJ.

Set the Trig MODE switch to the AUTO, and set the TIME/DIV switch to the 1 ms.

- Connect the digital voltmeter (DVM) to the R688 (or CR614) and ground.
- Adjust the INTENSITY control so that the DVM indicates 20 V.
- Observe the trace of CRT.
- Adjust the grid bias adjustment VR610 for the trace makes a just appear.

④ Check/adjust trace rotation.

- Position the trace to the center graticule line.
- Check that the trace is in parallel with the center horizontal line.
- Adjust TRACE ROTATION (screwdriver adjustment on front panel) for a trace that is in parallel with the horizontal graticule lines.

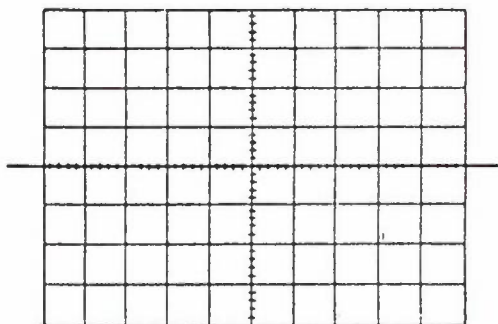

⑤ Check/geometry

- Set the TIME/DIV to the 0.1 ms, and the input coupling switch to DC.
- Connect the constant amplitude signal generator to the input.
- Set the VOLTS/DIV switch setting for a full-screen (8 division) deflection.
- Check that horizontal bowing is less than ± 0.35 division.

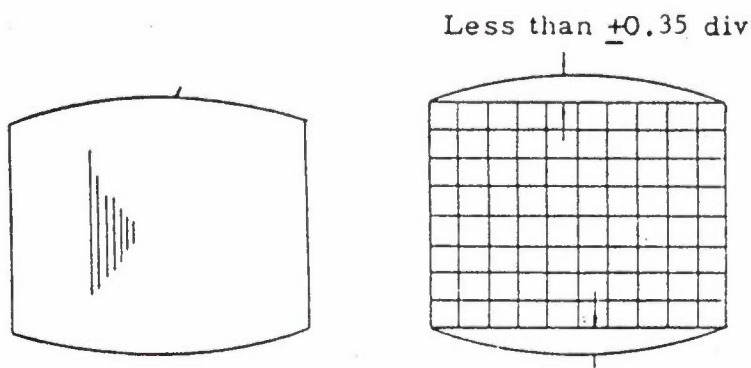

⑥ Check/adjust astigmatism and FOCUS.

- a. Set the TIME/DIV switch to the X-Y position, and the input coupling switch to GND.
- b. Set the INTENSity control for a small spot, as the following figure, using the position controls.

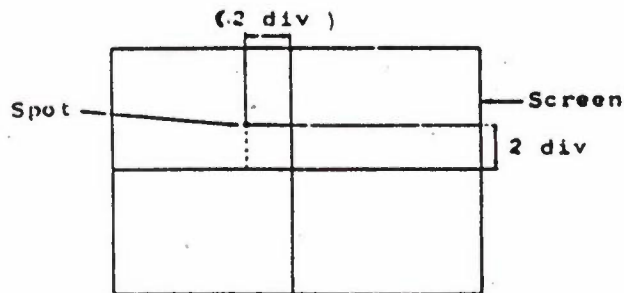

- c. Check that the spot is round.
- d. Adjust the FOCUS adjustment and astig. adjustment VR803 for a round spot.

HORIZONTAL SYSTEM

Control settings

Presct the controls as given in the preliminary control settings.

⑦ Check/adjust horizontal gain.

- a. Set the input AC-GND-DC to DC.
- b. Connect the cable to the output of the time mark generator.
- c. Set the time mark generator for 0.5ms time marks.
- d. Check that the time marks align with the graticule lines over the center eight divisions, within 3 %.
- e. Adjust the H GAIN adjustment VR605 so that the time marks coincide with the middle eight graticule lines.

⑧ Check/adjust Horizontal $\times 10$ MAG Gain.

- a. Set the TIME/DIV switch to 0.5ms.
- b. Set $\times 10$ MAG (pull out the knob of the POSITION control).
- c. Check that the one-cycle time marks align with the ten-divisions graticule lines, within 5 %.

- d. Adjust the MAG GAIN adjustment VR606 so that one-cycle time marks coincide with the ten-division graticule lines.
 - e. Push in the POSITION control after adjustment and check.
- ⑨ Check/adjust MAG CENT.
- a. Set the TIME/DIV switch to 0.5ms.
 - b. So that the knob of H.POSITION is pulled out (x10 MAG), the left end of the trace is brought to the center point and then the knob of H.POSITION is depressed.
 - c. Observe the movement of the left end of the trace.
 - d. Adjust the MAG CENT adjustment VR607 for the movement of the left end of the trace within ± 0.2 div.
- ⑩ Check/adjust low speed sweep accuracy.
- a. Set the time mark generator for 5 ms time marks.
 - b. Set the TIME/DIV switch to 5 ms.
 - c. Check that the time marks align with the graticule lines over the middle eight divisions, within 3 %.
 - d. Adjust the 5 ms/DIV adjustment VR609 so that the time marks coincide with the middle eight graticule lines.
- ⑪ Check/adjust high speed sweep accuracy.
- a. Set the input coupling switch to DC.
 - b. Set the time mark generator for 5 μ s time marks.
 - c. Set the TIME/DIV switch to 5 μ s.
 - d. Check that the time marks align with the graticule lines over the middle eight divisions.
 - e. Adjust VC601 so that the time marks coincide with middle eight graticule lines.

VERTICAL SYSTEM

- ⑫ Check/adjust DC balance (Step attenuator balance).
 - a. Set the VOLTS/DIV switch to the 5 mV position.
 - b. Position the trace to the horizontal center line.
 - c. Change the VOLTS/DIV switch to the 10 mV position.
 - d. Check that the trace is within ± 1.0 division of the center horizontal line.
 - e. Adjust the CH1 (CH2) DC balance adjustment, VR301(CH1) or VR401 (CH2), for a trace at the horizontal center line.
 - f. Repeat the part (a) through (e) until less than ± 0.05 division shift is noted when changing the VOLTS/DIV setting.
- ⑬ Check/adjust vertical position center.
 - a. Set the POSITION control of CH1(CH2) to center Position.
 - b. Set the V-MODE control to ALT mode.
 - c. Adjust the CH1(CH2) position center adjustment, VR304(VR404), for a trace at the horizontal center line.
- ⑭ Check/adjust $\times 1$ AC GAIN.
 - a. Set the TIME/DIV switch to the 1 ms position.
 - b. Set the VOLTS/DIV switch to the 10 mV position.
 - c. Set the input coupling switch to DC.
 - d. Connect the square-wave generator (using 1 kHz output range).
 - e. Adjust the output amplitude of that generator for 5 division deflection of screen.
 - f. Check the high-voltage level of pulse is flat.

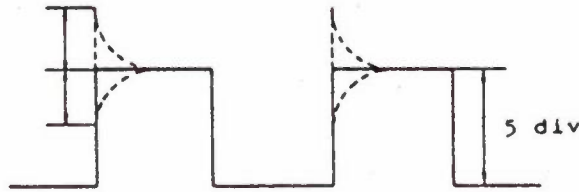

- g. Adjust the $\times 1$ AC GAIN VR302 (CH1), VR402 (CH2) adjustment for a flat level.
- ⑮ Check/adjust vertical gain.
- Set the VOLTS/DIV switch to the 10 mV position and the input coupling switch to DC.
 - Connect the standard amplitude calibrator to the input connector.
 - Set the standard amplitude calibrator for a 50 mVp-p (5 divisions for display) signal.
 - Check for a display of five divisions.
 - Adjust the GAIN adjustment VR303 (CH1), VR403 (CH2) for a display of 5 divisions within 3%.
 - Check all the VOLTS/DIV switch settings.
- ⑯ Check/adjust input capacity (ATT: $\div 1$).
- Set the VOLTS/DIV switch to the 10 mV position.
 - Set the input coupling switches to DC.
 - Connect the L-C meter to the input terminals.
 - Check the input capacity for approx. 23 pF.
- ⑰ Check/adjust vertical step response.
- Set the VOLTS/DIV switch to the 5 mV position.
 - Set the TIME/DIV switch to the 0.5 μ s position.
 - Connect the fast-rise, positive output (50 mV, 1 MHz) of the square-wave generator to the input. Use a 50 Ω termination and cable.
 - Adjust the square-wave generator output for a 5-divisions display.
 - CH1 - Adjust VC501 so that a square wave is flat.
CH2 Then, adjust VC502 for overshoot of +0.1 div.

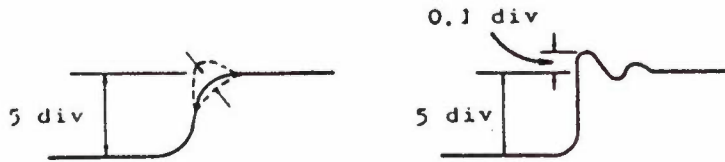

18 Check/adjust attenuation compensation.

(ATT : $\div 10$, $\div 100$)

- a. Set the input coupling switch to DC.
- b. Connect the square-wave generator to the CH1 (CH2) input terminal check for a square wave that is flat (flat top) under the following settings.

ATT	VOLTS/DIV	Square-wave-generator output
$\div 10$	0.1 V	0.5 V
$\div 100$	1 V	5 V

- c. Adjust the trimmer capacitors (refer to the circuit board illustration with adjustment location - page 60) for a square wave that is flat (flat top) under the following settings.

ATT	VOLTS/DIV	Square-wave generator output	Adjust CH1 (CH2)
$\div 10$	0.1 V	0.5 V	VC302 (VC402)
$\div 100$	1 V	5 V	VC 304 (VC404)

19 Check/adjust input capacity (ATT: $\div 10$, $\div 100$).

- a. Connect the L-C meter to the input connector.
- b. Check the input capacity for approximately 20 pF.
- c. Adjust the trimmer capacitors for a 2 pF input capacity under the following settings.

ATT	VOLTS/DIV	Adjust CH1 (CH2)
÷1	5mV	_____
÷10	0.1V	VC301(VC401)
÷100	1V	VC303(VC403)

②0 X-Y operation

20-1 Check/adjust X gain.

- a. Set the TIME/DIV switch to X-Y, the input coupling switch of CH1 to AC, the input coupling switch of CH2 to GND.
- b. Set the VOLTS/DIV switch to the 10mV position.
- c. Connect the standard amplitude calibrator to the CH1 input connector.
- d. Set the standard amplitude calibrator for 50mV.
- e. Check for a display of five divisions.
- f. Adjust the X GAIN adjustment VR608 for a display of five divisions within 6%.

20-2 Check/adjust X position center.

- a. Set the TIME/DIV switch to the X-Y position, and the horizontal POSITION control to the midposition, the input coupling switch of CH1 to GND.
- b. Check to see that the round spot is near the center graticule and is within +0.2 division against horizontal line.
- c. Adjust the X CENT adjustment VR305 to the position spot at the center.

20-3 Adjust and repeat in accordance to Par. 20-1-f and Par. 20-2-C in order to the same as Par. 20-1 and Par. 20-2.

②1 Check/adjust TRIG CENT.

- a. Set the TRIG COUPLE switch to AC, the TRIG SOURCE switch to CH1, the TRIG SLOPE knob push in, the VOLTS/DIV switch to 50mV, the TIME/DIV switch to 10uS.

- b. Connect the sine-wave generator to the input connector for a 0.5 div (50 kHz).
- c. Set the TRIG LEVEL knob to the midposition.
- d. Adjust VR602, so that synchronization is effected on the waveform, 0.5 div on the screen.
- e. Next, set the TRIG SLOPE to - (pulled out state) and insure that the waveform is triggered. After confirmation, leave the TRIG SLOPE in depressed state. Readjust when stepped out.

② Check/Adjust DC TRIG.

- a. Set the TRIG. COUPLE switch to DC, the TRIG. SOURCE to CH1, the VOLTS/DIV. to 50mV, the TIME/DIV. to 10uS.
- b. Connect the sine-wave generator to the input connector of CH1 for a 0.5 div(50KHz).
- c. Set the TRIG. level knob to the midposition.
- d. Adjust VR306 so that synchronization is effected on the waveform, 0.5 div on the screen.
- e. Next, set the TRIG. SLOPE to - (pull out state) and insure that the waveform is triggered. After confirmation, leave the TRIG. SLOPE in depressed state.
Readjust when stepped out.
- f. Repeat from a to e in CH2 with VR405 instead of VR306.

CALIBRATOR

- ⑳ Check/Adjust CAL. terminal(0.5Vp-p, 1KHz)
- a. Connect the CAL. terminal to the input of frequency counter(FC-5015)
 - b. Adjust VR408 so that the the frequency be 1KHz±20Hz.
 - c. Next, connect the CAL. terminal to the input of CH1.
 - d. Adjust VR407 so that 5 div. be abserved.
 - e. VOLTS/DIV. is set to 0.1mV

9. SEMICONDUCTOR LEAD CONFIGURATIONS

Table Marking for transistor electrode (bottom view)









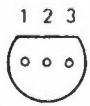

Type of transistor	Electrode marking
2SA1206 2SC2037 2SC2901 KSC1674Y	 <p>1. Emitter 2. Base 3. Collector</p>
2SK30A-Y 2SK304E	 <p>1. Source 2. Gate 3. Drain</p>
2SC1907 KTA1015Y KTC1815Y	 <p>1. Emitter 2. Collector 3. Base</p>
2N2907A	 <p>1. Source 2. Drain 3. Gate</p>
2SB861 2SD613	 <p>Top view 1. Base 2. Collector 3. Emitter</p>
2SB648A 2SD668A	 <p>1. Emitter 2. Collector 3. Base</p>
2SB718C 2SD758C	 <p>1. Base 2. Collector 3. Emitter</p>

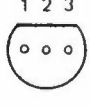
Table Marking for diode electrode

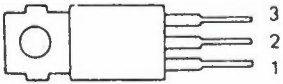
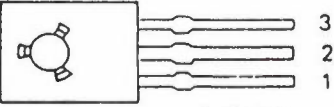
Type of diode	Electrode making	Polarity
1N4005 1N4148 1S953 ESJA52-12 1SS83		
DZ-2.4 DZ-24B DZ-5.1, DZ-9.1B DZ-5.6B		
WO-04S	<p style="text-align: center;">Top view</p> 	

10. ELECTRICAL PARTS LIST

(1), ATTENUATORS

PAGE:1

NO.	FND NO	DESCRIPTION & SPEC.	PART NUMBER	QTY	UNIT
1	ATT301	ATTENUATOR,ADR 255SA (E773-1036)	522-028	1	EA
2	ATT401	ATTENUATOR,ADR 255SA (E773-1036)	522-028	1	EA
3	C301	CAP M.F,400V,K, 0.047UF	CH2GL473K	1	EA
4	C302	CAP CER,50V,J,47PF(TC BLACK)	CT1HL470J	1	EA
5	C303	CAP CER,50V,K,220PF	CKIHL221K	1	EA
6	C304	CAP CER,50V,K,220PF	CK1HL221K	1	EA
7	C401	CAP M.F,400V,K,0.047UF	CH2GL473K	1	EA
8	C402	CAP CER,50V,J,47PF(TC BLACK)	CT1HL470J	1	EA
9	C403	CAP CER,50V,K,220PF	CKIHL221K	1	EA
10	C404	CAP CER,50V,K,220PF	CK1HL221K	1	EA
11	P301	CONNECTOR WAFER,LW-0640-02 H.L	531-001-7	1	EA
12	P401	CONNECTOR WAFER,LW-0640-02 H.L	531-001-7	1	EA
13	R301	RES,M.F,1/4W,0.5%,900K	RMBP9003D	1	EA
14	R302	RES,M.F,1/4W,0.5%,111K	RMBP1113D	1	EA
15	R303	WIRE BUS 10MM,0.60D	871-056	1	EA
16	R304	RES,M.F,1/4W,0.5%,990K	RMBP9903D	1	EA
17	R305	RES,M.F,1/4W,0.5%,10.1K	RMBP1012D	1	EA
18	R306	RES,C.F,1/4W,5%,22	REOBP220J	1	EA
19	R307	WIRE BUS 10MM,0.60D	871-056	1	EA
20	R401	RES,M.F,1/4W,0.5%,900K	RMBP9003D	1	EA
21	R402	RES,M.F,1/4W,0.5%,111K	RMBP1113D	1	EA
22	R403	WIRE BUS 10MM,0.6 D	871-056	1	EA
23	R404	RES,M.F,1/4W,0.5%,990K	RMBP9903D	1	EA
24	R405	RES,M.F,1/4W,0.5%,10.1K	RMBP1012D	1	EA
25	R406	RES,C.F,1/4W,5%,22	RDOBP220J	1	EA
26	R407	WIRE BUS 10MM,0.60D	871-056	1	EA
27	R499	RES,C.F,1/4W,5%,22	RDOBP220J	1	EA
28	S301	SWITCH LEVER,SLR 023	521-071	1	EA
29	S401	SWITCH LEVER,SLR 023	521-071	1	EA
30	VC301	CAP TRIMMER,CT5-N-10,0 - 10PF	581-133	1	EA
31	VC302	CAP TRIMMER,CT5-N-10,0 - 10PF	"	1	EA
32	VC303	CAP TRIMMER,CT5-N-10,0 - 10PF	"	1	EA
33	VC304	CAP TRIMMER,CT5-N-10,0 - 10PF	"	1	EA
34	VC401	CAP TRIMMER,CT5-N-10,0 - 10PF	"	1	EA
35	VC402	CAP TRIMMER,CT5-N-10,0 - 10PF	"	1	EA
36	VC403	CAP TRIMMER,CT5-N-10,0 - 10PF	"	1	EA
37	VC404	CAP TRIMMER,CT5-N-10,0 - 10PF	"	1	EA

NO.	FND NO	DESCRIPTION & SPEC.	PART NUMBER	QTY	UNIT
1	C305	CAP CER,500V,K,1000PF	CK2HL102K	1	EA
2	C306	CAP CER,50V,K,100PF(TC BLACK)	CT1HL101K	1	EA
3	C307	CAP CER,50V,Z,0.01UF	CK1HL103Z	1	EA
4	C308	CAP CER,50V,Z,1000PF	CK1HL102Z	1	EA
5	C309	CAP CER,50V,Z,0.01UF	CK1HL103Z	1	EA
6	C310	CAP CER,50V,Z,0.01UF	CK1HL103Z	1	EA
7	C311	CAP CER,50V,Z,1000PF	CK1HL102Z	1	EA
8	C312	CAP ELE,16V,R,100UF(SRA)	581-135	1	EA
9	C313	CAP ELE,16V,R,47UF(SRE)	581-134	1	EA
10	C314	CAP ELE,16V,R,100UF(SRA)	581-135	1	EA
11	C319	CAP CER,50V,Z,0.01UF	CK1HL103Z	1	EA
12	C320	CAP CER,50V,Z,0.01UF	CK1HL103Z	1	EA
13	C322	CAP ELE,16,R,100UF(SRA)	581-135	1	EA
14	C323	CAP ELE,16V,R,100UF(SRA)	581-135	1	EA
15	C325	CAP CER,50V,Z,4700PF	CK1HL472Z	1	EA
16	C326	CAP CER,50V,K,470PF	CK1HL471K	1	EA
17	C327	CAP ELE,16V,R,100UF(SRA)	581-135	1	EA
18	C328	CAP CER,50V,Z,0.01UF	CK1HL103Z	1	EA
19	C329	CAP ELE,(BP),16V,M,10UF	581-090-1	1	EA
20	C341	CAP CER,50V,Z,2700PF	CK1HL272Z	1	EA
21	CC301	CAP CHIP,18PF	983-012	1	EA
22	CR301	DIODE 1S1588 or DS4148	585-002	1	EA
23	CR302	DIODE ZENER,DZ-7.5B	585-075	1	EA
24	CR303	DIODE ZENER,DZ-9.1B	585-152	1	EA
25	L301	INDUCTOR,0.47UH,LALO4NAR47M	628-178	1	EA
26	LED301	LED,RED,KLR124E	588-031	1	EA
27	P303	CONNECTOR WAFER,LW-0640-03 H.L	531-002-7	1	EA
28	P306	CONNECTOR WAFER,LW-0640-04 H.L	531-033-7	1	EA
29	Q301	TRANSISTOR,2SC1907	611-184	1	EA
30	Q302	FET,2SK304E	611-140	1	EA
31	Q303	TRANSISTOR,KSC1674-Y	611-130-1	1	EA
32	Q304	TRANSISTOR,2SC2901	611-151	1	EA
33	Q305	TRANSISTOR,2SA1029D	611-133	1	EA
34	Q306	TRANSISTOR,2SC535C	611-155	1	EA
35	Q307	TRANSISTOR,2SC535C	611-155	1	EA
36	Q308	TRANSISTOR,2SA1029D	611-133	1	EA
37	Q309	TRANSISTOR,2SA1029D	611-133	1	EA
38	Q312	TRANSISTOR,2SC535C	611-155	1	EA
39	Q313	TRANSISTOR,2SC535C	611-155	1	EA
40	Q314	TRANSISTOR,2N2907A	611-016	1	EA
41	Q315	TRANSISTOR,2SC1907	611-184	1	EA
42	R308	RES,M.F,1/4W,0.5%,500K	RMBP5003D	1	EA
43	R309	RES,M.F,1/4W,0.5%,500K	RMBP5003D	1	EA
44	R311	RES,M.F,1/4W,1%,68	RMBP68ROF	1	EA
45	R312	RES,C.F,1/4W,5%,10	RDOBP100J	1	EA
46	R313	BUS WIRE,10MM,0.60D	871-056	1	EA
47	R314	RES,M.F,1/4W,1%,2.7K	RMBP ϕ 2R7F	1	EA
48	R315	RES,M.F,1/4W,1%,121	RMBP1210F	1	EA
49	R316	RES,M.F,1/4W,1%,3.3K	RMBP3301F	1	EA
50	R317	RES,M.F,1/4W,1%,3.3K	RMBP3301F	1	EA

NO.	FND NO	DESCRIPTION & SPEC.	PART NUMBER	QTY	UNIT
51	R318	RES,M.F,1/4W,1%,3.9K	RMBP3901F	1	EA
52	R319	RES,M.F,1/4W,1%,10K	RMBP1002F	1	EA
53	R320	RES,M.F,1/4W,1%,6.8K	RMBP6801F	1	EA
54	R321	RES,C.F,1/4W,5%,430	RDOBP431J	1	EA
55	R322	RES,M.F,1/4W,1%,680	RMBP6800F	1	EA
56	R323	RES,M.F,1/4W,1%,68	RMBP68ROF	1	EA
57	R325	RES,M F,1/4W,1%,820	RMBP8200F	1	EA
58	R326	RES,C.F,1/4W,5%,10	RCOBP100J	1	EA
59	R327	RES,M F,1/4W,0.5%,12K	RMBP1202D	1	EA
60	R328	RES,M.F,1/4W,0.5%,60K	RMBP6002D	1	EA
61	R329	RES,M.F,1/4W,0.5%,3K	RMBP3001D	1	EA
62	R330	RES,C.F,1/4W,5%,10	RDOBP100J	1	EA
63	R331	RES,C.F,1/4W,5%,10	RDOBP100J	1	EA
64	R332	RES,C.F,1/4W,5%,1K	RDOBP102J	1	EA
65	R334	RES,C.F,1/4W,5%,270K	RDOBP274J	1	EA
66	R335	RES,C.F,1/4W,5%,220	RDOBP221J	1	EA
67	R336	RES,M.F,1/4W,1%,4.7K	RMBP4701F	1	EA
68	R337	RES,M.F,1/4W,1%,4.7K	RMBP4701F	1	EA
69	R338	RES,C.F,1/4W,5%,27	RDOBP270J	1	EA
70	R340	RES,C.F,1/4W,5%,22	RDOBP220J	1	EA
71	R341	RES,M F,1/4W,1%,820	RMBP8200F	1	EA
72	R342	RES,M.F,1/4W,1%,820	RMBP8200F	1	EA
73	R344	RES,C.F,1/4W,5%,120	RDOBP121J	1	EA
74	R345	RES,C.F,1/4W,5%,22K	RDOBP223J	1	EA
75	R346	RES,M.F,1/4W,1%,1K	RMBP1001F	1	EA
76	R347	RES,M.F,1/4W,1%,1K	RMBP1001F	1	EA
77	R348	RES,M.F,1/4W,1%,3.3K	RMBP3301F	1	EA
78	R349	RES,M.F,1/4W,1%,3K	RMBP3001F	1	EA
79	R352	RES,M.F,1/4W,1%,15K	RMBP1502F	1	EA
80	R355	RES,M.F,1/4W,1%,3.3K	RMBP3301F	1	EA
81	R356	RES,M F,1/4W,1%,3.3K	RMBP3301F	1	EA
82	R357	RES,C.F,1/4W,5%,22	RDOBP220J	1	EA
83	R358	RES,C.F,1/4W,5%,56	RDOBP560J	1	EA
84	R360	RES,M.F,1/4W,1%,560	RMBP5600F	1	EA
85	R361	RES,M.F,1/4W,1%,560	RMBP5600F	1	EA
86	R362	RES,M.F,1/4W,1%,350	RMBP3500F	1	EA
87	R364	RES,M.F,1/4W,1%,1K	RMBP1001F	1	EA
88	R365	RES,C.F,1/4W,5%,150	RDOBP151J	1	EA
89	R366	RES,C.F,1/4W,5%,15K	RDOBP153J	1	EA
90	R367	RES,C.F,1/4W,5%,12	RDOBP120J	1	EA
91	R368	RES,C.F,1/4W,5%,10K	RDOBP103J	1	EA
92	R370	RES,C.F,1/4W,5%,2.7K	RDOBP272J	1	EA
93	R397	RES,C.F,1/4W,5%,4.7K	RDOBP472J	1	EA
94	R398	RES,M.F,1/4W,1%,430	RMBP4300F	1	EA
95	RA301	RES ARRAY,RA-OSC-V	591-325	1	EA
96	RC301	RES,CHIP,750	574-048	1	EA
97	U301	IC,LF356N	591-324	1	EA
98	VR301	RES SEMI FIXED,H1 ϕ 21A-22KB	572- ϕ 66	1	EA
99	VR302	RES SEMI FIXED,562Z-330B	572-305	1	EA
100	VR303	RES SEMI FIXED,562Z-100B	572-018	1	EA

NO.	FND NO	DESCRIPTION & SPEC.	PART NUMBER	QTY	UNIT
101	VR304	RES SEMI FIXED,562Z-47KB	572-002	1	EA
102	VR305	RES SEMI FIXED,562Z-10KB	572-001	1	EA
103	VR306	RES SEMI FIXED,H0621A-4,7KB	572-307	1	EA
104	C351	CAP CER 500V,+5%,470PF,TC	CT2HL471J	1	EA
105	R380	RES C.F,1/4W,+5%,33K	RDOB333J	1	EA
106	C318	CAP CER,50V,+5%,680PF,TC	CT1ML681J	1	EA
107	C350	CAP CER,500V,+5%,10PF,TC	CT2HL1 ϕ J	1	EA

NO.	FND NO	DESCRIPTION & SPEC.	PART NUMBER	QTY	UNIT
1	C405	CAP CER, 500V, Z, 1000PF	CK2HL102Z	1	EA
2	C406	CAP CER, 50V, K, 100PF (TC BLACK)	CT1HL101K	1	EA
3	C407	CAP CER, 50V, Z, 0.01UF	CK1HL103Z	1	EA
4	C408	CAP CER, 50V, Z, 1000PF	CK1HL102Z	1	EA
5	C409	CAP CER, 50V, Z, 0.01UF	CK1HL103Z	1	EA
6	C410	CAP CER, 50V, Z, 0.01UF	CK1HL103Z	1	EA
7	C411	CAP CER, 50V, Z, 1000PF	CK1HL102Z	1	EA
8	C412	CAP ELE, 16V, R, 100UF (SRA)	581-135	1	EA
9	C413	CAP ELE, 16V, R, 100UF (SRE)	581-134	1	EA
10	C414	CAP ELE, 16V, R, 100UF (SRA)	581-135	1	EA
11	C416	CAP CER, 50V, 5%, T.C, 47P	CT1HL470J	1	EA
12	C419	CAP CER, 50V, Z, 0.01UF	CK1HL103Z	1	EA
13	C420	CAP CER, 50V, Z, 0.01UF	CK1HL103Z	1	EA
14	C421	CAP CER, 50V, Z, 0.01UF	CK1HL103Z	1	EA
15	C422	CAP ELE, 16V, R, 100UF (SRA)	581-135	1	EA
16	C423	CAP ELE, 16V, R, 100UF (SRA)	581-135	1	EA
17	C425	CAP CER, 50V, Z, 4700PF	CK1HL472Z	1	EA
18	C426	CAP CER, 50V, K, 470PF	CK1HL471K	1	EA
19	C427	CAP ELE, 16V, R, 100UF (SRA)	581-135	1	EA
20	C428	CAP CER, 50V, Z, 0.01UF	CK1HL103Z	1	EA
21	C441	CAP CER, 50V, Z, 2700PF	CK1HL272Z	1	EA
22	CC401	CAP CHIP, 18PF	983-012	1	EA
23	CR401	DIODE, 1SS1588 or DS4148	585-002	1	EA
24	CR402	DIODE ZENER, DZ-7.5B	585-075	1	EA
25	L401	INDUCTOR, 0.47UH, LAL04NAR47M	628-178	1	EA
26	LED401	LED, RED, KLR124E	588-031	1	EA
27	P403	CPMMECTOR WAFER, LW-0640-03 H.L	531-002-7	1	EA
28	P404	CONNECTOR WAFER, LW-0640-03 H.L	531-002-7	1	EA
29	P405	CONNECTOR WAFER, LW-0640-02 H.L	531-001-7	1	EA
30	Q401	TRANSISTOR, 2SC1907	611-184	1	EA
31	Q402	FET, 2SK304E	611-140	1	EA
32	Q403	TRANSISTOR, KSC1674-Y	611-130-1	1	EA
33	Q404	TRANSISTOR, 2SC2901	611-151	1	EA
34	Q405	TRANSISTOR, 2SZ1029D	611-133	1	EA
35	Q406	TRANSISTOR, 2SC535C	611-155	1	EA
36	Q407	TRANSISTOR, 2SC535C	611-155	1	EA
37	Q408	TRANSISTOR, 2SA1029D	611-133	1	EA
38	Q409	TRANSISTOR, 2SA1029D	611-133	1	EA
39	Q410	TRANSISTOR, 2SA1029D	611-133	1	EA
40	Q411	TRANSISTOR, 2SA1029D	611-133	1	EA
41	Q412	TRANSISTOR, 2SC535C	611-155	1	EA
42	Q413	TRANSISTOR, 2SC535C	611-155	1	EA
43	Q414	TRANSISTOR, 2N2907A	611-016	1	EA
44	R408	RES, M.F, 1/4W, 0.5%, 500K	RMBP5003D	1	EA
45	R409	RES, M.F, 1/4W, 0.5%, 500K	RMBP5003D	1	EA
46	R410	RES, C.F, 1/4W, 5%, 10M	RDOCP106J	1	EA
47	R411	RES, M.F, 1/4W, 1%, 68	RMBP68ROF	1	EA
48	R412	RES, C.F, 1/4W, 5%, 10	RDOBP100J	1	EA
49	R413	WIRE BUS 10MM 0.60D	871-056	1	EA
50	R414	RES, C.F, 1/4W, 5%, 4.7K	RDOBP4701J	1	EA

NO.	FND NO	DESCRIPTION & SPEC.	PART NUMBER	QTY	UNIT
51	R415	RES,M.F,1/4W,1%,121	RMBP1210F	1	EA
52	R416	RES,M.F,1/4W,1%,3.3K	RMBP3301F	1	EA
53	R417	RES,M.F,1/4W,1%,3.3K	RMBP3301F	1	EA
54	R418	RES,M.F,1/4W,1%,3.9K	RMBP3901F	1	EA
55	R419	RES,M.F,1/4W,1%,10K	RMBP1002F	1	EA
56	R420	RES,M.F,1/4W,1%,6.8K	RMBP6801F	1	EA
57	R421	RES,C.F,1/4W,5%,430	RDOBP431J	1	EA
58	R422	RES,M.F,1/4W,1%,680	RMBP6800F	1	EA
59	R423	RES,M.F,1/4W,1%,68	RMBP68ROF	1	EA
60	R425	RES,M.F,1/4W,1%,820	RMBP8200F	1	EA
61	R426	RES,C.F,1/4W,5%,10	RDOBP100J	1	EA
62	R427	RES,M.F,1/4W,0.5%,12K	RMBP1202D	1	EA
63	R428	RES,M.F,1/4W,0.5%,60K	RMBP60Q2D	1	EA
64	R429	RES,M.F,1/4W,0.5%,3K	RMBP3001D	1	EA
65	R430	RES,C.F,1/4W,5%,10	RDOBP100J	1	EA
66	R431	RES,C.F,1/4W,5%,10	RDOBP100J	1	EA
67	R432	RES,C.F,1/4W,5%,1K	RDOBP102J	1	EA
68	R434	RES,C.F,1/4W,5%,270K	RDOBP274J	1	EA
69	R435	RES,C.F,1/4W,5%,220	RDOBP221J	1	EA
70	R436	RES,M.F,1/4W,1%,4.7K	RMBP4701F	1	EA
71	R437	RES,M.F,1/4W,1%,4.7K	RMBP4701F	1	EA
72	R438	RES,C.F,1/4W,5%,27	RDOBP270J	1	EA
73	R439	RES,M.F,1/4W,1%,220	RMBP2200F	1	EA
74	R440	RES,C.F,1/4W,5%,22	RDOBP220J	1	EA
75	R441	RES,M.F,1/4W,1%,820	RMBP8200F	1	EA
76	R442	RES,M.F,1/4W,1%,820	RMBP8200F	1	EA
77	R444	RES,C.F,1/4W,5%,120	RDOBP121J	1	EA
78	R445	RES,C.F,1/4W,5%,22K	RDOBP223J	1	EA
79	R446	RES,M.F,1/4W,1%,1K	RMBP1001F	1	EA
80	R447	RES,M.F,1/4W,1%,1K	RMBP1001F	1	EA
81	R448	RES,M.F,1/4W,1%,3.3K	RMBP3301F	1	EA
82	R449	RES,M.F,1/4W,1%,3K	RMBP3001F	1	EA
83	R450	RES,M.F,1/4W,1%,3K	RMBP3001F	1	EA
84	R451	RES,M.F,1/4W,1%,3.3K	RMBP3301F	1	EA
85	R452	RES,M.F,1/4W,5%,15K	RMBP1502F	1	EA
86	R453	RES,C.F,1/4W,5%,4.7K	RDOBP472J	1	EA
87	R455	RES,M.F,1/4W,1%,3.3K	RMBP3301F	1	EA
88	R456	RES,M.F,1/4W,1%,3.3K	RMBP3301F	1	EA
89	R457	RES,C.F,1/4W,5%,22	RDOBP220J	1	EA
90	R458	RES,C.F,1/4W,5%,56	RDOBP560J	1	EA
91	R459	RES,C.F,1/4W,5%,82	RDOBP820J	1	EA
92	R460	RES,M.F,1/4W,1%,560	RMBP5600F	1	EA
93	R461	RES,M.F,1/4W,1%,560	RMBP5600F	1	EA
94	R462	RES,M.F,1/4W,1%,350	RMBP3500F	1	EA
95	R463	RES,M.F,1/4W,1%,2.2K	RMBP2201F	1	EA
96	R464	RES,M.F,1/4W,1%,1K	RMBP1001F	1	EA
97	R465	RES,C.F,1/4W,5%,150	RDOBP151J	1	EA
98	R466	RES,C.F,1/4W,5%,15K	RDOBP153J	1	EA
99	R498	RES,M.F,1/4W,1%,430	RMBP4300F	1	EA
100	RA401	RES ARRAY,RA-OSC-V	591-325	1	EA

NO.	FND NO	DESCRIPTION & SPEC.	PART NUMEER	QTY	UNIT
101	RC401	RES,CHIP,750	574-048	1	EA
102	U401	IC,LF356N	591-324	1	EA
103	VR401	RES SEMI FIXED,H1 ϕ 21A-22KB	572- ϕ 66	1	EA
104	VR402	RES SEMI FIXED,562Z-330B	572-305	1	EA
105	VR403	RES SEMI FIXED,562Z-100B	572-018	1	EA
106	VR404	RES SEMI FIXED,562Z-47KB	572-002	1	EA
107	VR405	RES SEMI FIXED,562Z-10KB	572-001	1	EA
108	C451	CAP CER 500V,+5%,470PF,TC	CT2HL271J	1	EA
109	R480	RES C.F,1/4W,+5%,33K	RDOBP333J	1	EA
110	C450	CAP C.F,500V,+5%,10PF,T.C	CT2HL100J	1	EA

NO.	FND NO	DESCRIPTION & SPEC.	PART NUMBER	QTY	UNIT
1	C343	CAP CER, 50V, K, 470PF	CK1HL471K	1	EA
2	C430	CAP CER, 50V, Z, 1500PF	CK1HL152Z	1	EA
3	C433	CAP CER, 50V, J, 30PF (TC BLACK)	CT1CL300J	1	EA
4	C438	CAP P.P, 50V, K, 0.22UF	CQ1HL224K	1	EA
5	C443	CAP CER, 50V, K, 470PF	CK1HL471K	1	EA
6	CR304	DIODE, 1S953	585-147	1	EA
7	CR305	DIODE, 1S953	"	1	EA
8	CR306	DIODE, 1S953	"	1	EA
9	CR307	DIODE, 1S953	"	1	EA
10	CR404	DIODE, 1S953	"	1	EA
11	CR405	DIODE, 1S953	"	1	EA
12	CR406	DIODE, 1S953	"	1	EA
13	CR407	DIODE, 1S953	"	1	EA
14	CR410	DIODE, 1S953	"	1	EA
15	P302	CONNECTOR WAFER, LW-0640-02 H.L	531-001-7	1	EA
16	P304	CONNECTOR WAFER, LW-0640-03 H.L	531-002-7	1	EA
17	P305	CONNECTOR WAFER, LW-0640-02 H.L	531-001-7	1	EA
18	P407	CONNECTOR WAFER, LW-0640-02 H.L	531-001-7	1	EA
19	Q415	TRANSISTOR, KTA1015-Y	611-014-1	1	EA
20	Q416	TRANSISTOR, 2SC1907	611-184	1	EA
21	Q417	TRANSISTOR, 2SC1907	"	1	EA
22	Q418	TRANSISTOR, KTA1015-Y	611-014-1	1	EA
23	R376	RES, C.F, 1/4W, 5%, 100	RDOBP101J	1	EA
24	R377	RES, C.F, 1/4W, 5%, 27	RDOBP270J	1	EA
25	R378	RES, C.F, 1/4W, 5%, 2K	RDOBP202J	1	EA
26	R467	RES, C.F, 1/4W, 5%, 100	RDOBP101J	1	EA
27	R468	RES, C.F, 1/4W, 5%, 27	RDOBP270J	1	EA
28	R469	RES, C.F, 1/4W, 5%, 2K	RDOBP202J	1	EA
29	R470	RES, M.F, 1/4W, 0.5%, 680	RMBP6800F	1	EA
30	R471	RES, M.F, 1/4W, 0.5%, 680	RMBP6800F	1	EA
31	R472	RES, M.F, 1/4W, 1%, 220	RMBP2200F	1	EA
32	R473	RES, M.F, 1/4W, 1%, 220	RMBP2200F	1	EA
33	R474	RES, M.F, 1/4W, 1%, 470	RMBP4700F	1	EA
34	R475	RES, M.F, 1/4W, 1%, 470	RMBP4700F	1	EA
35	R476	RES, M.F, 1/4W, 1%, 130	RMBP1300F	1	EA
36	R477	RES, M.F, 1/4W, 1%, 100	RMBP1000F	1	EA
37	R478	RES, M.F, 1/4W, 1%, 130	RMBP1300F	1	EA
38	R479	RES, M.F, 1/4W, 1%, 15K	RMBP1502F	1	EA
39	R481	RES, C.F, 1/4W, 5%, 47	RDOBP470J	1	EA
40	R482	RES, C.F, 1/4W, 5%, 4.7K	RDOBP472J	1	EA
41	R483	RES, C.F, 1/4W, 5%, 4.7K	RDOBP472J	1	EA
42	R484	RES, C.F, 1/4W, 5%, 4.7K	RDOBP472J	1	EA
43	R485	RES, C.F, 1/4W, 5%, 2.2K	RDOBP222J	1	EA
44	R486	RES, C.F, 1/4W, 5%, 4.7K	RDOBP472J	1	EA
45	R487	RES, M.F, 1/4W, 1%, 100	RMBP1000F	1	EA
46	R491	RES, C.F, 1/4W, 5%, 4.7K	RDOBP472J	1	EA
47	R492	RES, C.F, 1/4W, 5%, 10K	RDOBP103J	1	EA
48	R493	RES, C.F, 1/4W, 5%, 4.7K	RDOBP472J	1	EA
49	R494	RES, C.F, 1/4W, 5%, 1.8K	RDOBP182J	1	EA
50	R495	RES, C.F, 1/4W, 5%, 820	RDOBP821J	1	EA

NO.	FND NO	DESCRIPTION & SPEC.	PART NUMBER	QTY	UNIT
51	R496	RES, C.F, 1/4W, 5%, 330	RDOBP331J	1	EA
52	R497	RES, C.F, 1/4W, 5%, 220	RDOBP221J	1	EA
53	R500	RES, M.F, 1/4W, 1%, 100	RMBP1000F	1	EA
54	S402	SWITCH LEVER, SLR 024	521-049	1	EA
55	U402	IC, FD74LS74A	591-074-9	1	EA
56	U403	IC, GD74LS14	591-075-9	1	EA
57	U404	IC, HD74LS00P	591-001Y	1	EA
58	VR407	RES SEMI FIXED, 562Z-470B	572-021	1	EA
59	VR408	RES, VAR SR19R-220-B.GSA	572-071	1	EA
60	C446	CAP C.F, 50V, Z, 2700PF	CK1EL104Z	1	EA

NO.	FND NO	DESCRIPTION & SPEC.	PART NUMBER	QTY	UNIT
1	C324	CAP ELE, 16V, R, 100UF (SRA)	581-135	1	EA
2	C434	CAP ELE, 16V, R, 100UF (SRA)	581-135	1	EA
3	C435	CAP CER, 50V, A, 0.01UF	CK1HL103Z	1	EA
4	C436	CAP CER, 50V, Z, 0.01UF	CK1HL103Z	1	EA
5	C437	CAP CER, 50V, Z, 0.01UF	CK1HL103Z	1	EA
6	C439	CAP ELE, 16V, R, 100UF (SRA)	581-135	1	EA
7	C440	CAP ELE, 16V, R, 100UF (SRA)	581-135	1	EA
8	C501	CAP CER, 50V, J, 100PF (TC BLACK)	CT1HL101J	1	EA
9	C502	CAP CER, 50V, J, 68PF (TC BLACK)	CT1HL680J	1	EA
10	C503	CAP CER, 500V, K, 82PF (T.C)	CT2HL820K	1	EA
11	C504	CAP CER, 500V, K, 82PF (T.C)	CT2HL820K	1	EA
12	C505	CAP CER, 500V, Z, 0.01UF	CK2HL103Z	1	EA
13	C506	CAP CER, 500V, Z, 0.01UF	CK2HL103Z	1	EA
14	C507	CAP CER, 500V, C, 1PF (TC BLACK)	CT2HL010C	1	EA
15	C508	CAP CER, 500V, C, 1.5PF (TC BLACK)	CT2HL1R5C	1	EA
16	C510	CAP CER, 500V, Z, 0.01UF	CK2HL103Z	1	EA
17	C511	CAP CER, 50V, Z, 0.01UF	CK1HL103Z	1	EA
18	C512	CAP CER, 50V, Z, 0.1UF	CK1HL104Z	1	EA
19	C513	CAP CER, 500V, z, 0.01UF	CK2HL103Z	1	EA
20	C514	CAP ELE, 16V, R, 100UF (SRA)	581-135	1	EA
21	C515	CAP ELE, 16V, R, 100UF (SRA)	581-135	1	EA
22	C516	CAP CER, 50V, J, 47PF (TC BLACK)	CT1HL470J	1	EA
23	CR501	DIODE ZENER, DZW-5.6	585-155	1	EA
24	CR502	DIODE ZENER, DZ-5.1	585-111	1	EA
25	CR503	DIODE ZENER, DZ-5.6B	585-056-1	1	EA
26	L501	INDUCTOR, 2.2UH, LAL04NA2R2M	628-179	1	EA
27	L502	INDUCTOR, 2.2UH, LAL04NA2R2M	"	1	EA
28	P408	CONNECTOR WAFER, LW 0640-05 H.L	531-018-7	1	EA
29	P501	CONNECTOR PIN, 5115	532-007	1	EA
30	P502	CONNECTOR PIN, 5115	"	1	EA
31	Q501	TRANSISTOR, 2SA1206	611-021	1	EA
32	Q502	TRANSISTOR, 2SA1206	"	1	EA
33	Q503	TRANSISTOR, 2SC2901	611-151	1	EA
34	Q504	TRANSISTOR, 2SC2901	611-151	1	EA
35	Q505	TRANSISTOR, KTA1015-Y	611-014-1	1	EA
36	Q506	TRANSISTOR, KTA1015-Y	"	1	EA
37	Q507	TRANSISTOR, 2SC2901	611-151	1	EA
38	Q508	TRANSISTOR, 2SC2901	611-151	1	EA
39	Q509	TRANSISTOR, KTA1015-Y	611-014-1	1	EA
40	Q510	TRANSISTOR, KTA1015-Y	"	1	EA
41	Q511	TRANSISTOR, 2SD758C	611-187	1	EA
42	Q512	TRANSISTOR, 2SD758C	"	1	EA
43	Q513	TRANSISTOR, 2SB718C	611-188	1	EA
44	Q514	TRANSISTOR, 2SB718C	"	1	EA
45	R501	RES, C.F, 1/4W, 5%, 6.8K	RDOBP682J	1	EA
46	R502	RES, M.F, 1/4W, 5%, 2.7K	RMBP2700F	1	EA
47	R503	RES, C.F, 1/4W, 1%, 1K	RDOBP102J	1	EA
48	R504	RES, M.F, 1/4W, 1%, 1K	RMBP1001F	1	EA
49	R505	RES, M.F, 1/4W, 1%, 1K	RMBP1001F	1	EA
50	R506	RES, C.F, 1/4W, 5%, 68	RDOBP680J	1	EA

NO.	FND NO	DESCRIPTION & SPEC.	PART NUMBER	QTY	UNIT
51	R507	RES,M.F,1/4W,1%,100	RMBP1000F	1	EA
52	R508	RES,M.F,1/4W,1%,100	RMBP1000F	1	EA
53	R509	RES,C.F,1/4W,5%,10	RDOBP100J	1	EA
54	R510	RES,C.F,1/4W,5%,220	RDOBP221J	1	EA
55	R511	RES,C.F,1/4W,5%,330	RDOBP331J	1	EA
56	R512	RES,C.F,1/4W,5%,330	RDOBP331J	1	EA
57	R513	RES,M.F,1/4W,1%,330	RMBP3300F	1	EA
58	R514	RES,M.F,1/4W,1%,330	RMBP3300F	1	EA
59	R515	RES,C.F,1/4W,5%,1K	RDOBP102J	1	EA
60	R516	RES,C.F,1/4W,5%,1K	RDOBP102J	1	EA
61	R517	RES,C.F,1/4W,5%,22	RDOBP220J	1	EA
62	R518	RES,C.F,1/4W,5%,22	RDOBP220J	1	EA
63	R519	RES,M.F,1/4W,1%,1K	RMBP1001F	1	EA
64	R520	RES,M.F,1/4W,1%,1K	RMBP1001F	1	EA
65	R521	RES.M.O,2W,5%,12K	RS02P123J	1	EA
66	R522	RES,M.O,2W,5%,12K	RS02P123J	1	EA
67	R523	RES,M.O,2W,5%,12K	RS02P123J	1	EA
68	R524	RES,M.O,2W,5%,12K	RS02P123J	1	EA
69	R525	RES,M.O,1W,5%,27K	RS01P273J	1	EA
70	R526	RES,C.F,1/4W,5%,220	RDOBP221J	1	EA
71	R527	RES,C.F,1/4W,5%,220	RDOBP221J	1	EA
72	R528	RES,M.F,1/4W,1%,150	RMBP1500F	1	EA
73	R529	RES,M.F,1/4W,1%,150	RMBP1500F	1	EA
74	R530	RES,M.F,1/4W,1%,100	RMBP1000F	1	EA
75	R531	RES,M.F,1/4W,1%,1K	RMBP1001F	1	EA
76	R532	RES,M.F,1/4W,1%,1K	RMBP1001F	1	EA
77	R533	RES,M.O,1W,5%,150	RS01P151J	1	EA
78	R534	RES,C.F,1/4W,5%,270K	RDOBP274J	1	EA
79	R535	RES,C.F,1/4W,5%,279K	RDOBP274J	1	EA
80	TH501	THERMISTOR,NTC 4.7 OHM	579-015	1	EA
81	VC501	CAP TRIMMER,CT5-N-40,0 - 40PF	581-132	1	EA
82	VC502	CAP TRIMMER,CT5-N-40,0 - 40PF	"	1	EA
83	VR501	RES SEMI FIXED,562Z-1KB	572-005	1	EA

NO.	FNE NO	DESCRIPTION & SPEC.	PANT NUMBER	QTY	UNIT
1	C601	CAP M.F,250V,K,0.047UF	CH2EL473K	1	EA
2	C602	CAP CER,50V,K,330PF	CK1HL331K	1	EA
3	C603	CAP CER,50V,Z,1000PF	CK1HL102Z	1	EA
4	C604	CAP ELE,(BP),50V,M,1UF	581-117	1	EA
5	C605	CAP CER,50V,Z,0.01UF	CK1HL103Z	1	EA
6	C606	CAP CER,50V,J,33PF	CK1HL330J	1	EA
7	C608	CAP CER,50V,Z,0.01UF	CK1HL103Z	1	EA
8	C666	CAP ELE,25V,R,22UF(SM)	CE1EL226R	1	EA
9	C668	CAP ELE,25V,R,22UF(SM)	CE1EL226R	1	EA
10	C689	CAP CER,50V,Z,0.01UF	CK1HL103Z	1	EA
11	C690	CAP ELE,25V,R,22UF(SM)	CE1EL226R	1	EA
12	C691	CAP ELE,25V,R,22UF(SM)	CE1EL226R	1	EA
13	CR601	DIODE,1S953	585-147	1	EA
14	P601	CONNECTOR WAFER,LW-0640-02 H.L	531-001-7	1	EA
15	P602	CONNECTOR WAFER,LW-0640-04 H.L	531-003-7	1	EA
16	P603	CONNECTOR WAFER,LW-0640-02 H.L	531-001-7	1	EA
17	Q601	FET,2SK30A-Y	611-182	1	EA
18	Q602	TRANSISTOR,2SC2037	611-183	1	EA
19	Q603	TRANSISTOR,2SC2037	611-183	1	EA
20	Q604	TRANSISTOR,KTA1015-Y	611-014-1	1	EA
21	R601	RES,C.F,1/4W,5%,5.6K	RDOBP562J	1	EA
22	R602	RES,C.F,1/4W,5%,10K	RDOBP103J	1	EA
23	R603	RES,C.F,1/4W,5%,3K	RDOBP302J	1	EA
24	R604	RES,C.F,1/4W,5%,33K	RDOBP333J	1	EA
25	R605	RES,C.F,1/4W,5%,12K	RDOBP123J	1	EA
26	R606	RES,C.F,1/4W,5%,3.3K	RDOBP332J	1	EA
27	R607	RES,C.F,1/4W,5%,39K	RDOBP393J	1	EA
28	R608	RES,C.F,1/4W,5%,470K	RDOBP474J	1	EA
29	R609	RES,C.F,1/4W,5%,100	RDOBP101J	1	EA
30	R610	RES,C.F,1/4W,5%,10K	RDOBP103J	1	EA
31	R612	RES,C.F,1/4W,5%,15K	REOBP153J	1	EA
32	R613	RES,C.F,1/4W,5%,10K	RDOBP103J	1	EA
33	R614	RES,C.F,1/4W,5%,22	RDOBP220J	1	EA
34	R615	RES,C.F,1/4W,5%,22	RDOBP220J	1	EA
35	R616	RES,C.F,1/4W,5%,470	RDOBP471J	1	EA
36	R728	RES,C.F,1/4W,5%,1K	RDOB H02J	1	EA
37	S601	SWITCH LEVER,SLR 024	521-049K	1	EA
38	S602	SWITCH LEVER,SLR 024	521-049K	1	EA
39	S603	SWITCH LEVER,SLR 024	521-049K	1	EA
40	VR601	RES VAR,V16L4 PCB TYPE(E113-10061)	571-057	1	EA
41	VR602	RES SEM FIXED,562Z-47KB	572-002	1	EA
42	R618	RES,C.F,1/4W,5%,1.2K	RDOBP122J	1	EA
43	CR626	DIODE,1S1588 OR DS4148	585-002	1	EA
44	C696	CAP MYLAR,400V,0.002UF	CP2GL223K	1	EA
45	C698	CAP CER,500V,+5%,47PF	CK2HL470J	1	EA

NO.	FND NO	DESCRIPTION & SPEC.	PATR NUMBER	QTY	UNIT
1	C612	CAP CER, 50V, C, 1PF	CK1HL010C	1	EA
2	C616	CAP CER, 50V, J, 39PF	CK1HL390J	1	EA
3	C617	CAP CER, 50V, J, 82PF(TC BLACK)	CT1HL820J	1	EA
4	C622	CAP CER, 50V, J, 10PF	CK1HL100J	1	EA
5	C623	CAP CER, 50V, C, 1 PF	CK1HL010C	1	EA
6	C678	CAP ELE, 25V, R, 22UF(SM)	CE1EL226R	1	EA
7	C680	CAP ELE, 25V, R, 2.2UF(SM)	CE1EL225R	1	EA
8	C681	CAP ELE, 25V, R, 22UF(SM)	CE1EL226R	1	EA
9	C682	CAP ELE, 25V, R, 22UF(SM)	CE1EL226R	1	EA
10	C683	CAP ELE, 25V, R, 22UF(SM)	CE1EL226R	1	EA
11	C684	CAP ELE, 25V, R, 22UF(SM)	CE1EL226R	1	EA
12	C692	CAP ELE, 25V, R, 22UF(SM)	CE1EL226R	1	EA
13	C693	CAP ELE, 250V, R, 4.7UF(SM)	CE2EL475R	1	EA
14	CR603	DIODE, 1S953	585-147	1	EA
15	CR604	DIODE, 1S953	585-147	1	EA
16	CR605	DIODE, 1S953	585-147	1	EA
17	K601	RELAY, MZ-12HS	526-020	1	EA
18	LED601	LED, GRN, KLG124E	588-032	1	EA
19	P607	CONNECTOR WAFER, LW-0640-02 H.L	531-001-7	1	EA
20	P608	CONNECTOR WAFER, LW-0640-03 H.L	531-002-7	1	EA
21	Q605	FET, 2SK, 304E	611-140	1	EA
22	Q606	TRANSISTOR, 2SC1907	611-184	1	EA
23	Q607	TRANSISTOR, 2SC2901	611-151	1	EA
24	Q608	TRANSISTOR, 2SA1206	611-021	1	EA
25	Q609	TRANSISTOR, KTC1815-Y	611-001-1	1	EA
26	R625	RES, C.F, 1/4W, 5%, 2.2K	RDOBP222J	1	EA
27	R627	RES, C.F, 1/4W, 5%, 33K	RDOBP333J	1	EA
28	R628	RES, C.F, 1/4W, 5%, 100	RDOBP101J	1	EA
29	R629	RES, C.F, 1/4W, 5%, 4.7K	RDOBP472J	1	EA
30	R631	RES, C.F, 1/4W, 5%, 15K	RDOBP153J	1	EA
31	R632	RES, C.F, 1/4W, 5%, 82	RDOBP820J	1	EA
32	R633	RES, C.F, 1/4W, 5%, 100	RDOBP101J	1	EA
33	R634	RES, C.F, 1/4W, 5%, 10K	RDOBP103J	1	EA
34	R635	RES, C.F, 1/4W, 5%, 4.7K	RDOBP472J	1	EA
35	R636	RES, C.F, 1/4W, 5%, 4.7K	RDOBP472J	1	EA
36	R637	RES, C.F, 1/4W, 5%, 2K	RDOBP202J	1	EA
37	R638	RES, C.F, 1/4W, 5%, 120K	RDOBP124J	1	EA
38	R675	RES, C.F, 1/4W, 5%, 56K	RDOBP563J	1	EA
39	R676	RES, C.F, 1/4W, 5%, 470	RDPBP471J	1	EA
40	R712	RES, C.F, 1/4W, 5%, 4.7K	RDOBP472J	1	EA
41	R713	RES, C.F, 1/4W, 5%, 3.3K	RDOBP332J	1	EA
42	R714	RES, C.F, 1/4W, 5%, 47	RDOBP470J	1	EA
43	R715	RES, C.F, 1/4W, 5%, 4.7K	RDOBP472J	1	EA
44	R716	RES, C.F, 1/4W, 5%, 1K	RDOBP102J	1	EA
45	R717	RES, C.F, 1/4W, 5%, 1K	RDOBP102J	1	EA
46	R718	RES, C.F, 1/4W, 5%, 1K	RDOBP102J	1	EA
47	R732	RES, C.F, 1/4W, 5%, 100	REOBP101J	1	EA
48	U601	IC, SN74LS122N	591-212	1	EA
49	U602	IC, HD74LSOOP	591-001Y	1	EA
50	U603	IC, GD74LS14	591-075-9	1	EA

NO.	RND NO	DESCRIPTION & SPEC.	PART NUMBER	QTY	UNIT
51	U604	IC,GD74LS74A	591-074-9	1	EA
52	U605	IC,GD74LS10	591-045-9	1	EA
53	U607	IC,TL072CP	591-323	1	EA
54	VC601	CAP TRIMMER,CT5-N-40,0 - 40PF	581-132	1	EA
55	VR604	RES SEMI FIXED,562Z-2,2KB	572-006	1	EA
56	VR608	RES SEMI FIXED,562Z-2,2KB	572-006	1	EA
57	Z601	DIODE ZENER,DZ-24B	585-150	1	EA
58	C697	CAP CER 50V 0.01UF	CK1HL103K	1	EA
59	R734	RES,C.F,1/4W,5%,4.7K	REOBP472J	1	EA
60	CR627	DIODE 1S1588 OR DS 4148	585-002	1	EA
61	CR628	DIODE 1S1588 OR DS 4148	585-002	1	EA

(8), TIMING CIRCUIT

PAGE:15

NO.	FND NO	DESCRIPTION & SPEC.	PART NUMBER	QTY	UNIT
1	C610	CAP M.F,250V,F,1UF	CH2EL105F	1	EA
2	C611	CAP M.F,250V,F,0.01UF	CH2EL103F	1	EA
3	C618	CAP M.F,250V,K,0.047UF	CH2EL473K	1	EA
4	C619	CAP ELE,25V,R,1UF(SM)	CE1EL105R	1	EA
5	C620	CAP CER,50V,K,680PF	CK1HL681K	1	EA
6	C679	CAP ELE,25V,R,47UF(SM)	CE1EL476R	1	EA
7	CR602	DIODE,1N4148	585-002	1	EA
8	L604	RELAY,MZ-5HS	526-025	1	EA
9	LED602	LED,RED,KLR,124E	588-031	1	EA
10	P606	CONNECTOR WAFER,LW-0640-02 HALIM	531-001-7	1	EA
11	R611	RES,C.F,1/4W,5%,390	RDOBP391J	1	EA
12	R617	RES,M.F,1/4W,0.5%,110K	RMBP1103D	1	EA
13	R619	RES,M.F,1/4W,0.5%,4.4M	RMBP4404D	1	EA
14	R620	RES,M.F,1/4W,0.5%,1.1M	RMBP1104D	1	EA
15	R621	RES,M.F,1/4W,0.5%,220K	RMBP2203D	1	EA
16	R622	RES,M.F,1/4W,0.5%,2.2M	RMBP2204D	1	EA
17	R623	RES,M.F,1/4W,0.5%,440K	RMBP4403D	1	EA
18	R624	RES,C.F,1/4W,5%,470	RDOBP471J	1	EA
19	R626	RES,C.F,1/4W,5%,270	RDOBP271J	1	EA
20	R630	RES,M.F,1/4W,1%,680K	RMBP6803F	1	EA
21	R729	RES,M.F,1/4W,0.5%,44K	RMBP4402D	1	EA
22	R733	RES,C.F,1/4W,5%,1.2K	RDOBP122J	1	EA
23	S605	SWITCH ROTARY,8394003	522-027	1	EA
24	VR603	RES VAR,V16L5ZS (E113-3146)	571-054	1	EA
25	VR609	RES SEMI FIXED,562Z-2.2KB	572-006	1	EA

NO.	FND NO	DESCRIPTION & SPEC.	PART NUMBER	QTY	UNIT
1	C626	CAP CER, 50V, D, 5PF (TC BLACK)	CT1HL050D	1	EA
2	C630	CAP CER, 50V, J, 22PF (TC BLACK)	CT1HL220J	1	EA
3	C631	CAP CER, 500V, K, 1000PF	CK2HL102K	1	EA
4	C633	CAP MYLAR, 250V, K, 0.047UF	CP2EL473K	1	EA
5	C634	CAP ELE, 25V, R, 22UF (SM)	CE1EL226R	1	EA
6	C635	CAP CER, 500V, K, 470PF	CK2HL471K	1	EA
7	C637	CAP MYLAR, 250V, K, 0.047UF	CP2EL473K	1	EA
8	C672	CAP CER, 500V, Z, 0.01UF	CK2HL103Z	1	EA
9	C673	CAP ELE, 25V, R, 22UF (SM)	CE1EL226R	1	EA
10	C674	CAP ELE, 25V, R, 22UF (SM)	CE1EL226R	1	EA
11	C675	CAP ELE, 25V, R, 22UF (SM)	CE1EL226R	1	EA
12	C676	CAP ELE, 25V, R, 22UF (SM)	CE1EL226R	1	EA
13	C677	CAP ELE, 25V, R, 22UF (SM)	CE1EL226R	1	EA
14	C685	CAP ELE, 25V, R, 22UF (SM)	CE1EL226R	1	EA
15	C687	CAP ELE, 25V, R, 22UF (SM)	CE1EL226R	1	EA
16	C688	CAP ELE, 25V, R, 22UF (SM)	CE1EL226R	1	EA
17	CR607	DIODE, 1S953	585-147	1	EA
18	CR608	DIODE, 1N4148	585-002	1	EA
19	CR609	DIODE, 1N4148	585-002	1	EA
20	CR624	DIODE, 1N4148	585-002	1	EA
21	K603	RELAY, MZ-12HS	526-020	1	EA
22	P609	CONNECTOR WAFER, LW-0640-04 H.L	531-003-7	1	EA
23	P610	CONNECTOR WAFER, LW-0640-07 H.L	531-059-7	1	EA
24	Q611	TRANSISTOR, 2SC1907	611-184	1	EA
25	Q612	TRANSISTOR, 2SC1907	611-184	1	EA
26	Q613	TRANSISTOR, 2SA1206	611-021	1	EA
27	Q614	TRANSISTOR, 2SC1907	611-184	1	EA
28	Q615	TRANSISTOR, 2SA1206	611-021	1	EA
29	Q616	TRANSISTOR, 2SC1907	611-184	1	EA
30	Q617	TRANSISTOR, 2SD668A	611-185	1	EA
31	Q618	TRANSISTOR, 2SB648A	611-186	1	EA
32	Q619	TRANSISTOR, 2SB648A	611-186	1	EA
33	Q620	TRANSISTOR, 2SD668A	611-185	1	EA
34	R641	RES, M.F, 1/4W, 1%, 330	RMBP3300F	1	EA
35	R642	RES, C.F, 1/4W, 5%, 18K	RDOBP183J	1	EA
36	R643	RES, V.F, 1/4W, 1%, 5.6K	RMBP5601F	1	EA
37	R644	RES, M.F, 1/4W, 1%, 1.2K	RMBP1201F	1	EA
38	R645	RES, M.F, 1/4W, 1%, 1K	RMBP1001F	1	EA
39	R646	RES, M.F, 1/4W, 1%, 2.2K	RMBP2201F	1	EA
40	R647	RES, C.F, 1/4W, 5%, 180	RDOBP181J	1	EA
41	R649	RES, M.F, 1.4W, 1%, 1.2K	RMBP1201F	1	EA
42	R650	RES, M.F, 1/4W, 1%, 5.6K	RMBP5601F	1	EA
43	R651	RES, M.F, 1/4W, 1%, 2.2K	RMBP2201F	1	EA
44	R652	RES, M.F, 1/2W, 1%, 100K	RMBP1003F	1	EA
45	R653	RES, V.F, 1/4W, 1%, 560	RMBP5600F	1	EA
46	R654	RES, C.F, 1/4W, 5%, 1.5K	RDOBP152J	1	EA
47	R655	RES, C.F, 1/4W, 5%, 27	RDOBP270J	1	EA
48	R656	RES, M.F, 1/4W, 1%, 8.2K	RMBP8201F	1	EA
49	R657	RES, M.F, 1/4W, 1%, 8.2K	RMBP8201F	1	EA
50	R658	RES, C.F, 1/4W, 5%, 1.8K	RDOBP182J	1	EA

NO.	FND NO	DESCRIPTION & SPEC.	PART NUMBER	QTY	UNIT
51	R659	RES, M.F, 1/4W, 1%, 1.2K	RMBP1201F	1	EA
52	R660	RES, C.F, 1/2W, 5%, 270K	RDOCP274J	1	EA
53	R661	RES, M.F, 1/4W, 1%, 18K	RMBP1802F	1	EA
54	R662	RES, C.F, 1/4W, 5%, 2K	RDOCP202J	1	EA
55	R663	RES, C.F, 1/4W, 5%, 100	RDOBP101J	1	EA
56	R664	RES, C.F, 1/2W, 5%, 47K	RDOCP473J	1	EA
57	R665	RES, M.F, 1/4W, 1%, 2.2K	RMBP2201F	1	EA
58	R666	RES, M.F, 1/4W, 1%, 18K	RMBP1802F	1	EA
59	R667	RES, M.F, 1/4W, 1%, 1.2K	RMBP1201F	1	EA
60	R668	RES, C.F, 1/4W, 5%, 1.5K	RDOBP152J	1	EA
61	R669	RES, M.F, 1/4W, 1%, 560	RMBP5600F	1	EA
62	R670	RES, M.F, 1/2W, 1%, 100K	RMCP1003F	1	EA
63	R671	RES, C.F, 1/2W, 5%, 270K	RDOCP274J	1	EA
64	R672	RES, C.F, 1/2W, 5%, 47K	RDOCP473J	1	EA
65	R674	RES, C.F, 1/4W, 5%, 100	RDOBP101J	1	EA
66	R721	RES, C.F, 1/4W, 5%, 10	RDOBP100J	1	EA
67	R722	RES, C.F, 1/4W, 5%, 10	RDOBP100J	1	EA
68	R723	RES, C.F, 1/4W, 5%, 10	RDOBP100J	1	EA
69	R724	RES, C.F, 1/4W, 5%, 10	RDOBP100J	1	EA
70	VR605	RES SEMI FIXED, 562Z-1KB	572-005	1	EA
71	VR606	RES SEMI FIXED, H ϕ 621A-100B	572-035	1	EA
72	VR607	RES SEMI FIXED, H ϕ 621A-1KB	572-035	1	EA
73	R702	RES, C.F, 1/8W, 5%, 18K	RDOAP183J	1	EA
74	C632	CAP CER, 500V, K, 100PF	CK2HL101K	1	EA

NO.	FND NO	DESCRIPTION & SPEC.	PART NUMBER	QTY	UNIT
1	C641	CAP CER,50V,Z,1000PF	CK1HL102Z	1	EA
2	C642	CAP CER,50V,K,100PF	CK1HL101K	1	EA
3	C643	CAP CER,50V,K,470PF	CK1HL471K	1	EA
4	C667	CAP ELE,25V,R,22UF(SM)	CE1EL226R	1	EA
5	CR610	DIODE,1S953	585-147	1	EA
6	CR611	DIODE,1S953	585-147	1	EA
7	P604	CONNECTOR WAFER,LW-0640-02 H.L	531-001-7	1	EA
8	P605	CONNECTOR WAFER,LW-0640-04 H.L	531-003-7	1	EA
9	R677	RES,C.F,1/4W,5%,2.2K	RDOBP222J	1	EA
10	R678	RES,C.F,1/4W,5%,2.2K	RDOBP222J	1	EA
11	R680	RES,C.F,1/4W,5%,2.2K	RDOBP222J	1	EA
12	R725	RES,C.F,1/4W,5%,270	RDOBP271J	1	EA
13	U606	IC,GD74LS02	591-054-9	1	EA
14	CR629	DIODE,1S1588 OR DS 4148	585-002	1	EA
15	C687	CAP ELE,25V,22UF	CE1EL226R	1	EA

NO.	FND NO	DESCRIPTION & SPEC.	PART NUMBER	QTY	UNIT
1	C649	CAP MYLAR, 400V, F, 0.022UF	CP2GL223K	1	EA
2	C650	CAP MYLAR, 250V, K, 0.047UF	CP2EL473K	1	EA
3	C651	CAP CER, 2KV, Z, 0.01UF	CK2FL103Z	1	EA
4	C652	CAP CER, 3KV, 1000PF, DE1110E102M	CK3FL102M	1	EA
5	C653	CAP CER, 3KV, 1000PF, DE1110E102M	CK3FL102M	1	EA
6	C654	CAP CER, 2KV, Z, 0.01UF	CK2FL103Z	1	EA
7	C655	CAP CER, 2KV, Z, 0.01UF	CK2FL103Z	1	EA
8	C656	CAP CER, 2KV, Z, 0.01UF	CK2FL103Z	1	EA
9	C657	CAP CER, 2KV, Z, 0.01UF	CK2FL103Z	1	EA
10	C658	CAP CER, 3KV, 1000PF, DE1110E102M	CK3FL102M	1	EA
11	C659	CAP ELE, 160V, R, 1UF(SM)	CE2CL105R	1	EA
12	C660	CAP CER, 50V, 0.02UF	CK1HL224Z	1	EA
13	C661	CAP ELE, 25V, R, \$&UF(SM)	CE1EL476R	1	EA
14	C663	CAP ELE, 25V, R, 47UF(SM)	CE1EL476R	1	EA
15	C664	CAP CER, 50V, Z, 4700PF	CK1HL472Z	1	EA
16	C669	CAP ELE, 25V, R, 22UF(SM)	CE1EL226R	1	EA
17	C670	CAP ELE, 25V, R, 22UF(SM)	CE1EL226R	1	EA
18	C694	CAP ELE, 25V, R, 100UF(SM)	CE1EL107R	1	EA
19	C825	CAP CER, 500V, Z, 0.01UF	CK2HL103Z	1	EA
20	C828	CAP CER, 500V, Z, 0.01UF	CK2HL103Z	1	EA
21	CR614	DIODE, 1SS83	585-132	1	EA
22	CR615	DIODE, 1SS83	585-132	1	EA
23	CR616	DIODE, ESJA52-12	585-149	1	EA
24	CR617	DIODE, ESJA52-12	"	1	EA
25	CR618	DIODE, ESJA52-12	"	1	EA
26	CR619	DIODE, ESJA52-12	"	1	EA
27	CR620	DIODE, 1S953	585-147	1	EA
28	CR621	DIODE, 1N4148	585-002	1	EA
29	CR622	DIODE, 1N4148	585-002	1	EA
30	F601	FUSE, 125/250V, 0.25A, MF51NMTYPE	563-040	1	EA
31	FH601	PUSE PIN 20mm, PCB Type	563-037	1	EA
32	NL601	NEON-LAMP, NE-68	561-009	1	EA
33	NL602	NEON-LAMP, NE-68	561-009	1	EA
34	P611	CONNECTOR WAFER, LW-0640-03	531-002-7	1	EA
35	P612	CONNECTOR WAFER, LW-0640-06	531-005-7	1	EA
36	P613	CONNECTOR WAFER, LW-0640-02	531-001-7	1	EA
37	P805	CONNECTOR WAFER, LW-0640-04	531-003-7	1	EA
38	P806	CONNECTOR WAFER, LW-0640-03	531-002-7	1	EA
39	P807	CONNECTOR WAFER, LW-0640-02	531-001-7	1	EA
40	P808	CONNECTOR WAFER, LW-0640-02	531-001-7	1	EA
41	Q621	TRANSISTOR, 2SC1907	611-184	1	EA
42	Q622	TRANSISTOR, 2SC1907	611-184	1	EA
43	Q623	TRANSISTOR, 2SD668A	611-185	1	EA
44	Q629	TRANSISTOR, 2SD613D	611-125Y	1	EA
45	Q630	RTANSISTOR, KTC1815-Y	611-001-1	1	EA
46	Q631	TRANSISTOR, KTA1015-Y	611-014-1	1	EA
47	Q632	TRANSISTOR, 2SB648A	611-186	1	EA
48	Q806	TRANSISTOR, 2SD668A	611-185	1	EA
49	R679	RES, C. F, 1/4W, 5%, 2.2K	RDOBP222J	1	EA
50	Q807	TRANSISTOR, KTA1 ϕ 15	611-014-1	1	EA

NO.	FND NO	DESCRIPTION & SPEC.	PART NUMBER	QTY	UNIT
51	R681	RES,C.F,1/4W,5%,18K	RDOBP183J	1	EA
52	R682	RES,C.F,1/2W,5%,47K	RDOCP473J	1	EA
53	R683	RES,C.F,1/4W,5%,3.9K	RDOBP392J	1	EA
54	R684	RES,C.F,1/4W,5%,4.8K	RDOBP472J	1	EA
55	R685	RES,C.F,1/4W,5%,470	RDOBP471J	1	EA
56	R686	RES,M.F,1/4W,1%,139K	RMBP1393F	1	EA
57	R687	RES,C.F,1/4W,5%,47K	RDOBP473J	1	EA
58	R688	RES,C.F,1/4W,5%,220	RDOBP221J	1	EA
59	R689	RES,C.F,1/4W,5%,10K	RDOBP103J	1	EA
60	R691	RES,C.F,1/4W,5%,1K	RDOBP102J	1	EA
61	R692	RES,C.F,1/4W,5%,1.5K	RDOBP152J	1	EA
62	R693	RES,C.F,1/4W,5%,10K	RDOBP103J	1	EA
63	R694	RES,C.F,1/4W,5%,330K	RDOBP334J	1	EA
64	R695	RES,C.F,1/2W,1%,16M	RGCP1605F	1	EA
65	R696	RES,C.F,1/4W,5%,100K	RDOBP104J	1	EA
66	R697	RES,C.F,1/4W,5%,3M	RDOBP305J	1	EA
67	R698	RES,C.F,1/4W,5%,82K	RDOBP823J	1	EA
68	R699	RES,C.F,1/4W,5%,100K	RDOBP104J	1	EA
69	R700	RES,C.F,1/2W,1%,16M	RGCP1605F	1	EA
70	R701	RES,C.F,1/4W,5%,270K	RDOBP274J	1	EA
71	R705	RES,C.F,1/4W,5%,330	RDOBP331J	1	EA
72	R706	RES,C.F,1/4W,5%,100K	RDOBP104J	1	EA
73	R708	RES,C.F,1/4W,5%,1.2K	RDOBP122J	1	EA
74	R709	RES,C.F,1/4W,5%,390	RDOBP391J	1	EA
75	R710	RES,C.F,1/4W,5%,1.5K	RDOBP152J	1	EA
76	R711	RES,C.F,1/4W,5%,680	RDOBP681J	1	EA
77	R719	RES,C.F,1/4W,5%,10	RDOBP100J	1	EA
78	R720	RES,C.F,1/4W,5%,10	RDOBP100J	1	EA
79	R726	RES,C.F,1/4W,5%,2.2	RDOBP2R2J	1	EA
80	R727	RES,C.F,1/4W,5%,8.2K	RDOBP822J	1	EA
81	R730	RES,C.F,1/4W,5%,7.5K	RDOBP752J	1	EA
82	R825	RES,C.F,1/2W,5%,130	RDOCP131J	1	EA
83	R826	RES,C.F,1/4W,5%,82K	RDOBP823J	1	EA
84	R827	RES,C.F,1/4W,5%,100K	RDOBP104J	1	EA
85	T601	TRANSFORMER,HVT-3D 4011	622-017	1	EA
86	VR610	RES SEMI FIXED,562Z-220KB	572-003	1	EA
87	VR803	RES SEMI FIXED,562Z-220KB	572-003	1	EA
88	R735	RES,C.F,1/4W,5%,2.7K	RDOBP272J	1	EA

NO.	FND NO	DESCRIPTION & SPEC.	PART NUMBER	QTY	UNIT
1	C801	CAP ELE, 25V, R, 2200UF (SMS)	CE1EL228R	1	EA
2	C803	CAP CER, 50V, Z, 0.22UF	CK1HL224Z	1	EA
3	C804	CAP CER, 50V, Z, 0.1UF	CK1HL104Z	1	EA
4	C805	CAP ELE, 25V, R, 220UF (SM)	CE1EL227R	1	EA
5	C806	CAP CER, 50V, Z, 0.22UF	CK1HL224Z	1	EA
6	C807	CAP ELE, 25V, R, 220UF (SM)	CE1EL227R	1	EA
7	C808	CAP CER, 50V, Z, 0.1UF	CK1HL104Z	1	EA
8	C809	CAP ELE, 25V, R, 220UF (SM)	CE1EL227R	1	EA
9	C810	CAP ELE, 25V, R, 2200UF (SMS)	CE1EL228R	1	EA
10	C812	CAP CER, 50V, Z, 0.22UF	CK1HL224Z	1	EA
11	C813	CAP CER, 50V, Z, 0.1UF	CK1HL104Z	1	EA
12	C814	CAP ELE, 25V, R, 220UF (SM)	CE1EL227R	1	EA
13	C815	CAP ELE, 100V, R, 47UF (SM)	CE2AL476R	1	EA
14	C816	CAP ELE, 100V, R, 47UF (SM)	CE2AL476R	1	EA
15	C817	CAP ELE, 100V, R, 4.7UF (SM)	CE2AL475R	1	EA
16	C818	CAP ELE, 250V, R, 47UF (SRA)	581-137	1	EA
17	C819	CAP ELE, 250V, R, 47UF (SRA)	581-137	1	EA
18	C820	CAP ELE, 250V, R, 4.7UF (SM)	CE2EL475R	1	EA
19	C821	CAP ELE, 50V, R, 1000UF (SM)	CE1HL108R	1	EA
20	C822	CAP ELE, 35V, R, 470UF (SMS)	581-139	1	EA
21	C823	CAP ELE, 35V, R, 470UF (SMS)	581-139	1	EA
22	C824	CAP ELE, 35V, R, 470UF (SMS)	581-139	1	EA
23	CR801	DIODE BRIDGE, WO-04S (400V1.5A)	585-153	1	EA
24	CR802	DIODE BRIDGE, WO-04S (400V1.5A)	585-153	1	EA
25	CR803	DIODE, 1N4148	585-002	1	EA
26	CR804	DIODE BRIDGE, WO-04S (400V1.5A)	585-153	1	EA
27	CR805	DIODE BRIDGE, WO-04S (400V1.5A)	585-153	1	EA
28	CR806	DIODE, 1N4148	585-002	1	EA
29	CR807	DIODE, 1N4005	585-154	1	EA
30	CR808	DIODE BRIDGE, WO-04S (400V1.5A)	585-153	1	EA
31	P801	CONNECTOR WAFER, LW-1143-04 H.L	531-072-7	1	EA
32	P802	CONNECTOR WAFER, LW-1143-07 H.L	531-016-7	1	EA
33	P803	CONNECTOR WAFER, LW-0640-02 H.L	531-001-7	1	EA
34	P804	CONNECTOR WAFER, LW-0640-02 H.L	531-001-7	1	EA
35	P809	CONNECTOR WAFER, LW-0640-03 H.L	531-002-7	1	EA
36	P810	CONNECTOR WAFER, LW-0640-07 H.L	531-059-7	1	EA
37	P811	CONNECTOR WAFER, LW-0640-05 H.L	531-018-7	1	EA
38	P812	CONNECTOR WAFER, LW-0640-03 H.L	531-002-7	1	EA
39	P813	CONNECTOR WAFER, LW-0640-02 H.L	531-001-7	1	EA
40	Q801	TRANSISTOR, 2SB861	611-189	1	EA
41	Q802	TRANSISTOR, 2SB861	611-189	1	EA
42	Q803	TRANSISTOR, 2SD613D	611-125Y	1	EA
43	R801	RES, M.F, 1/4W, 1%, 12K	RMBP1202F	1	EA
44	R802	RES, M.F, 1/4W, 1%, 12K	RMBP1202F	1	EA
45	R803	RES, C.F, 1/4W, 5%, 560K	RDOB564J	1	EA
46	R804	RES, C.F, 1/4W, 5%, 27K	RDOB273J	1	EA
47	R805	RES, C.F, 1/4W, 5%, 130K	RDOB134J	1	EA
48	R806	RES, C.F, 1/4S, 5%, 27K	RDOB273J	1	EA
49	R807	RES, M.O, 2W, 5%, 4.7K	RS02P472J	1	EA
50	R808	RES, C.F, 1/4W, 5%, 8.2	RDOB8R2J	1	EA

NO.	FND NO	DESCRIPTION & SPEC.	PART NUMBER	QTY	UNIT
51	R809	RES, M.F, 1/4W, 1%, 82	RMBP82ROF	1	EA
52	R810	RES, M.F, 1/4W, 1%, 455	RMBP4550F	1	EA
53	R811	RES, C.F, 1/2W, 5%, 47	RDOCP470J	1	EA
54	R812	RES, 2W, 5%, 1.5K	RSO2P152J	1	EA
55	R813	RES, C.F, 1/4W, 5%, 6.8	RDOBP688J	1	EA
56	R814	RES, M.F, 1/4W, 1%, 100	RMBP1000F	1	EA
57	R815	RES, C.F, 1/4W, 5%, 10K	RDOBP103J	1	EA
58	R816	RES, M.F, 1/4W, 1%, 270	RMBP2700F	1	EA
59	R817	RES, C.F, 1/4W, 5%, 560	RDOBP561J	1	EA
60	R818	RES, M.F, 1/4W, 1%, 130K	RMBP1303F	1	EA
61	R819	RES, C.F, 1/4W, 5%, 1K	RDOBP102J	1	EA
62	R824	RES, C.F, 1/4W, 5%, 1.5K	RDOBP152J	1	EA
63	R828	RES, C.F, 1/4W, 5%, 560	RDOBP561J	1	EA
64	U802	IC, GL7912	595-009	1	EA
65	U803	IC, GL7805	591-310-9	1	EA
66	U804	IC, TL071CP	591-279S	1	EA
67	U805	IC, TL071CP	591-279S	1	EA
68	U806	IC, UA7818	591-326	1	EA
69	U807	IC, TL071CP	591-279S	1	EA
70	VR801	RES SEMI FIXED, 562Z-10KB	572-001	1	EA

NO.	FND NO	DESCRIPTION & SPEC.	PART NUMBER	QTY	UNIT
1		PCB SC10,LAMP BOARD	513-281	1	EA
2		PCB SC3,VERTICAL BOARD	513-284	1	EA
3		PCB SC6,HORIZONTAL BOARD	513-283	1	EA
4		PCB SC8,POWER SUPPLY BOARD	513-285	1	EA
5		PCB SC9,CRT SOCKET BOARD	513-282	1	EA
6		CRT,150BTB31A	631-007	1	EA
7	F101	FUSE,125V 2A,MF51NM Type	563-035	1	EA
8	J902	SOCKET CRT,S-Bo891-01	535-017	1	EA
9	L101	ROTATION COIL,20M	638-005	1	EA
10	LED101	LED,GRN,KLG114E	588-020	1	EA
11	P101	CONNECTOR,BNC-RB(UG-1094/U)	531-164	1	EA
12	P102	CONNECTOR,BNC-RB(UC-1094/U)	531-164	1	EA
13	P103	CONNECTOR,BNC-RB(UC-1094/U)	531-164	1	EA
14	P104	CONNECTOR,BNC-RB(UG-1094/U)	531-164	1	EA
15	P105	CONNECTOR,BNC-RB(UG-1094/U)	531-164	1	EA
16	P106	TERMINAL,CAL OUT	539-010	1	EA
17	P107	TERMINAL GROUND	537-018	1	EA
18	P108	ACINLET,GSS42R34FOR2T	531-170	1	EA
19	P901	CONNECTOR WAFER,LW-0640-02 H.L	531-001-7	1	EA
20	PL1001	LAMP,100mA14V	561-020	1	EA
21	PL1002	LAMP,100mA14V	561-020	1	EA
22	PL1003	LAMP,100mA14V	561-020	1	EA
23	R101	RES,C.F,1/4W,5%,47	RDOBP470J	1	EA
24	R102	RES,C.F,1/4W,5%,47	RDOBP470J	1	EA
25	R103	RES,C.F,1/4W,5%,120	RDOBP121J	1	EA
26	SW101	SWITCH POWER,SDL1P	521-070	1	EA
27	T101	TRANSFORMER ASS'Y,POWER	622-016	1	EA
28	TL101	TERMINAL LUG,GP840074	537-037	1	EA
29	VR101	RES VAR,K161100-10KB	571-056	1	EA
30	VR102	RES VAR,K161100-10KB	571-056	1	EA
31	VR103	RES VAR,VM16N (E708-1068)	571-058	1	EA
32	VR104	RES VAR,K161100-10KB	571-056	1	EA
33	VR105	RES VAR,K16110-5KB	571-044	1	EA
34	VR106	RES VAR,K161110-5M111-50KB	571-053	1	EA
35	VR107	RES VAR,V16L4 LUG TYPE(E113-10061)	571-055	1	EA
36	VR108	RES VAR,V16L4 LUG TYPE(E113-10061)	571-055	1	EA
*****	*****	***** PART-LIST of OS-7020	//	The End	*****

SC-6. HORIZONTAL BOARD

11. ELECTRICAL PARTS ARRANGEMENT (With Adjustment Locations)

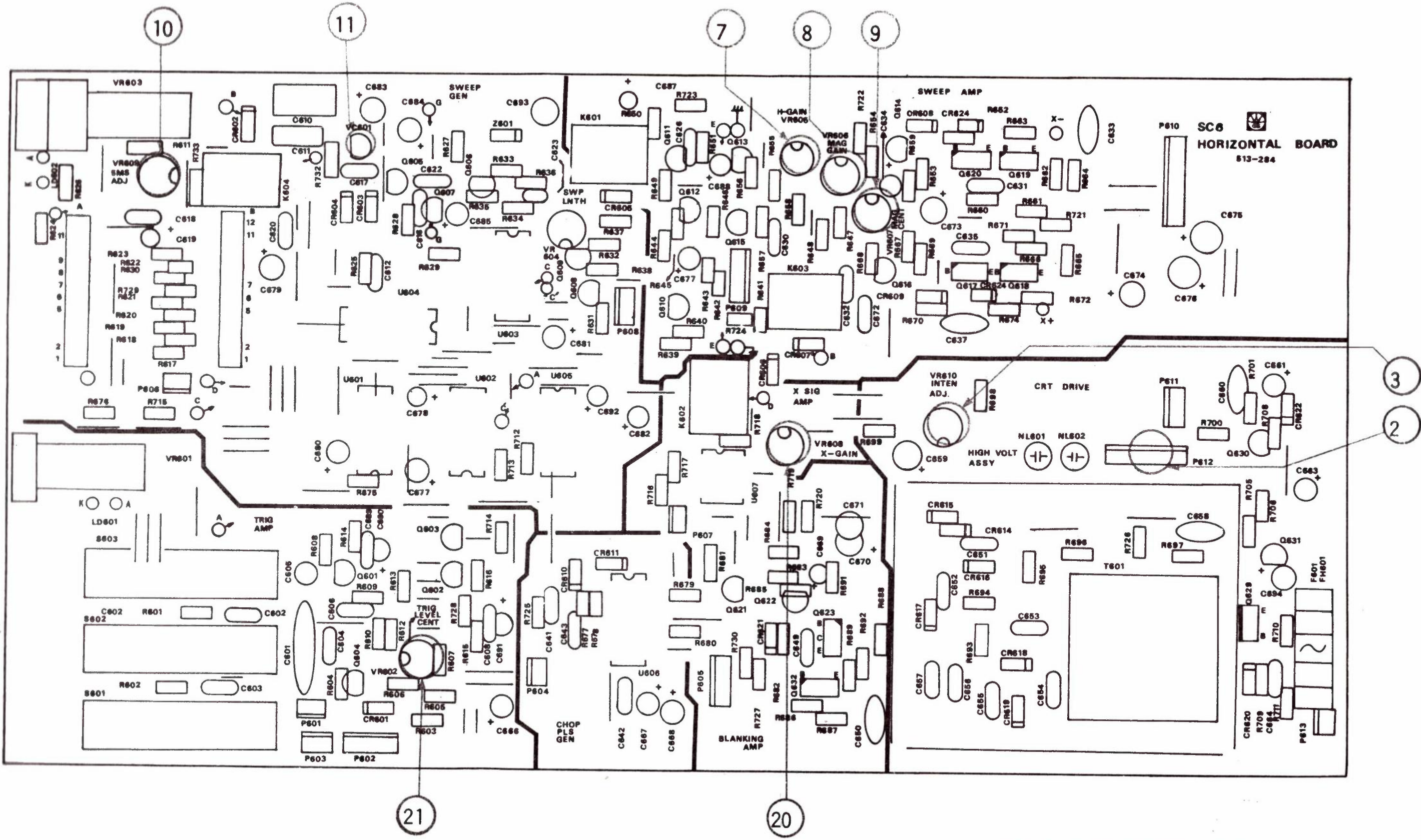

SC-6. HORIZONTAL BOARD

SC-3. VERTICAL BOARD

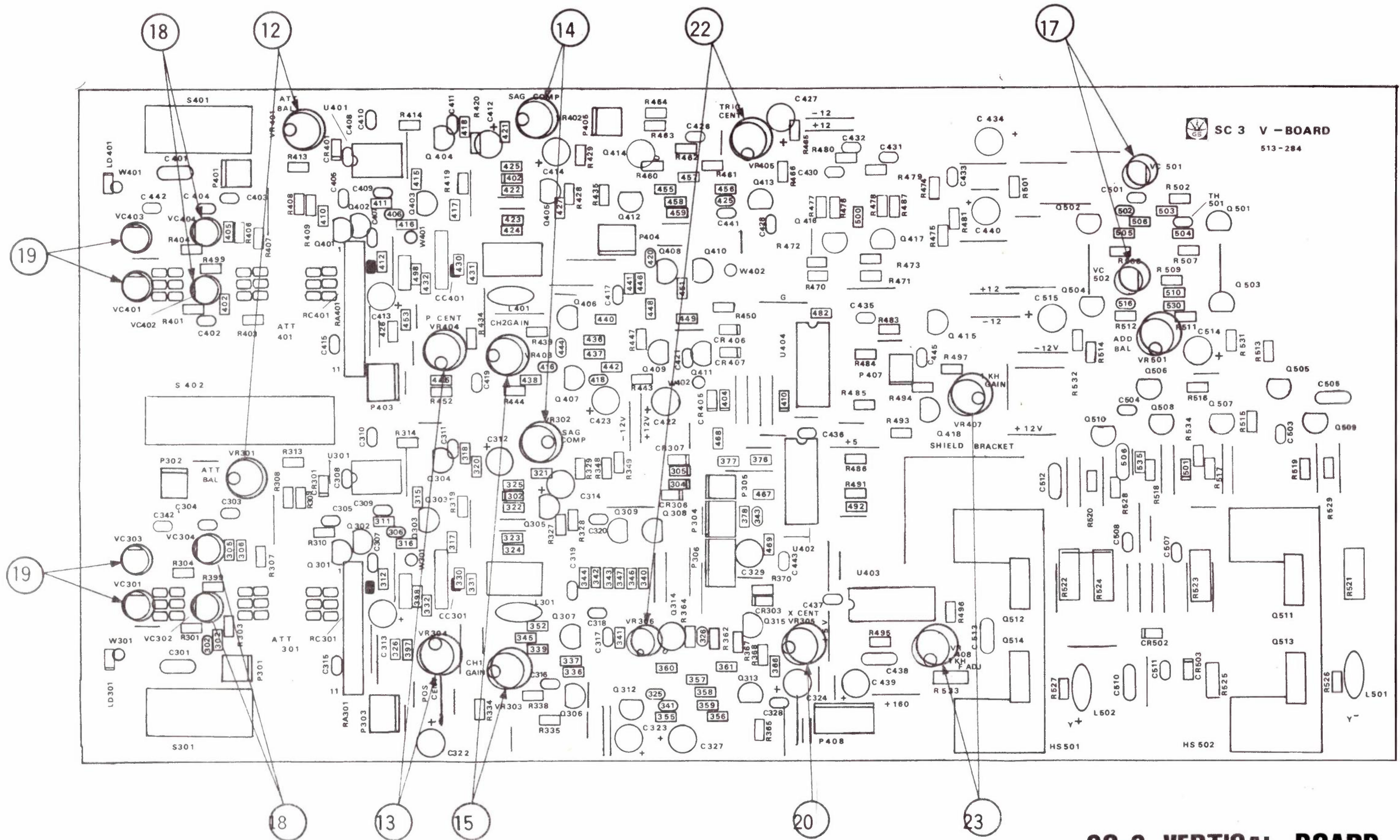

SC-3. VERTICAL BOARD

SC-8. POWER SUPPLY BOARD

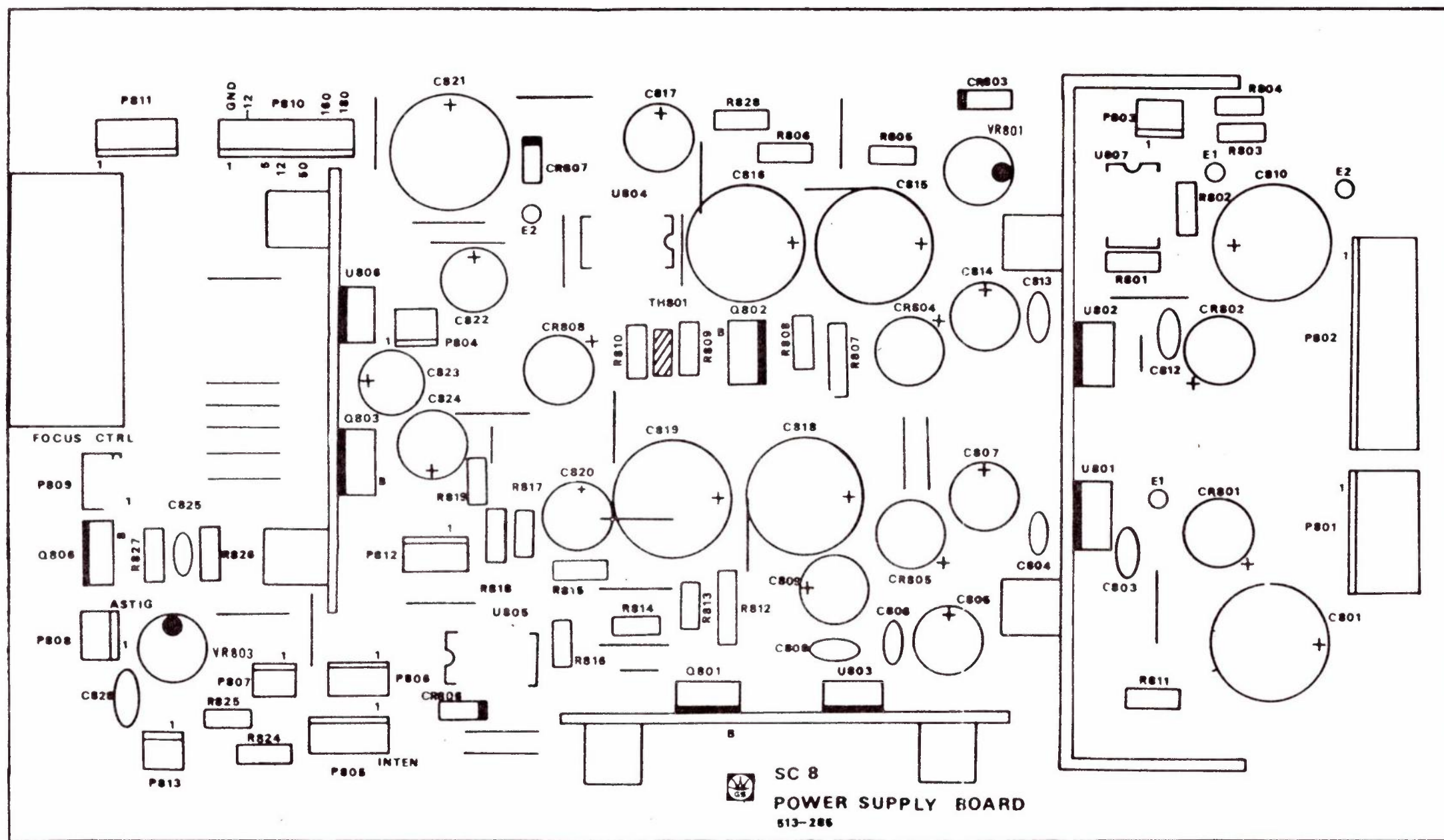

SC-8 POWER SUPPLY BOARD

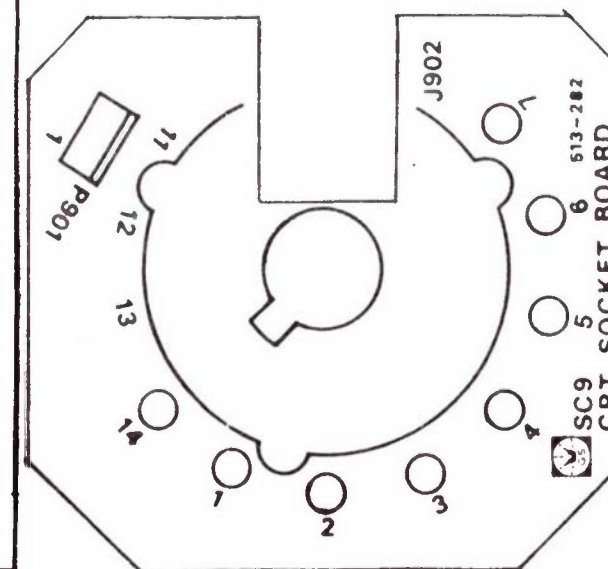

SC-9 CRT SOCKET BOARD



SC-10 LAMP BOARD

BLOCK DIAGRAM

12. BLOCK DIAGRAM

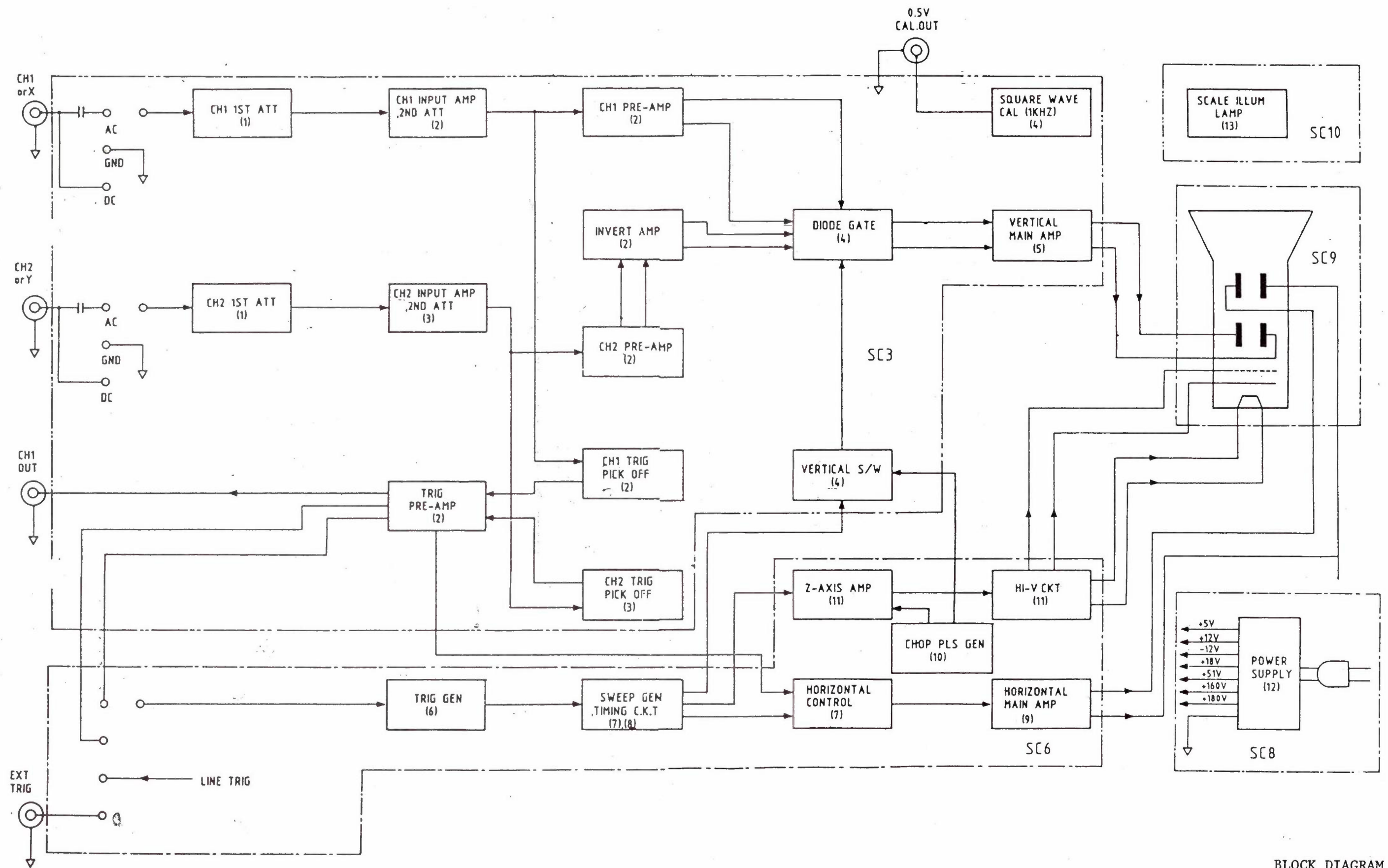

BLOCK DIAGRAM

ATTENUATOR (1)

13. SCHEMATIC DIAGRAMS

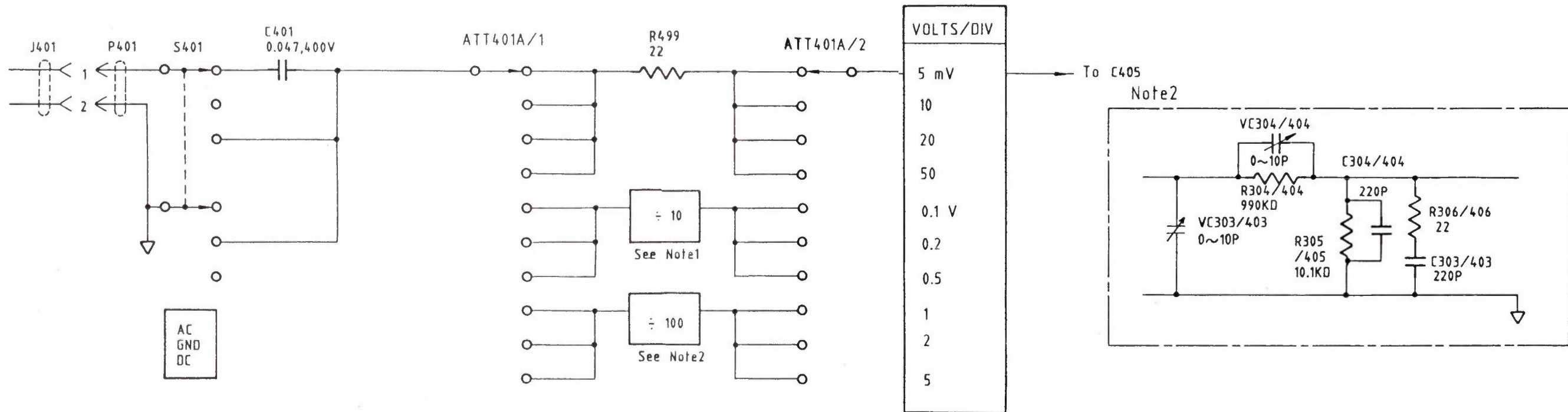
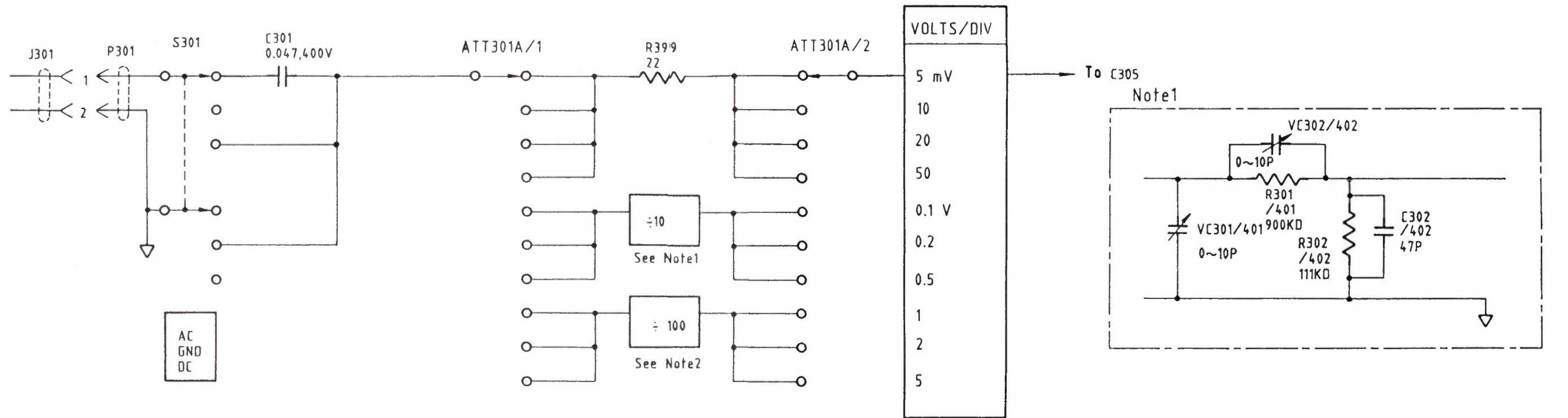

CH1 LNPUT AMP.(2)

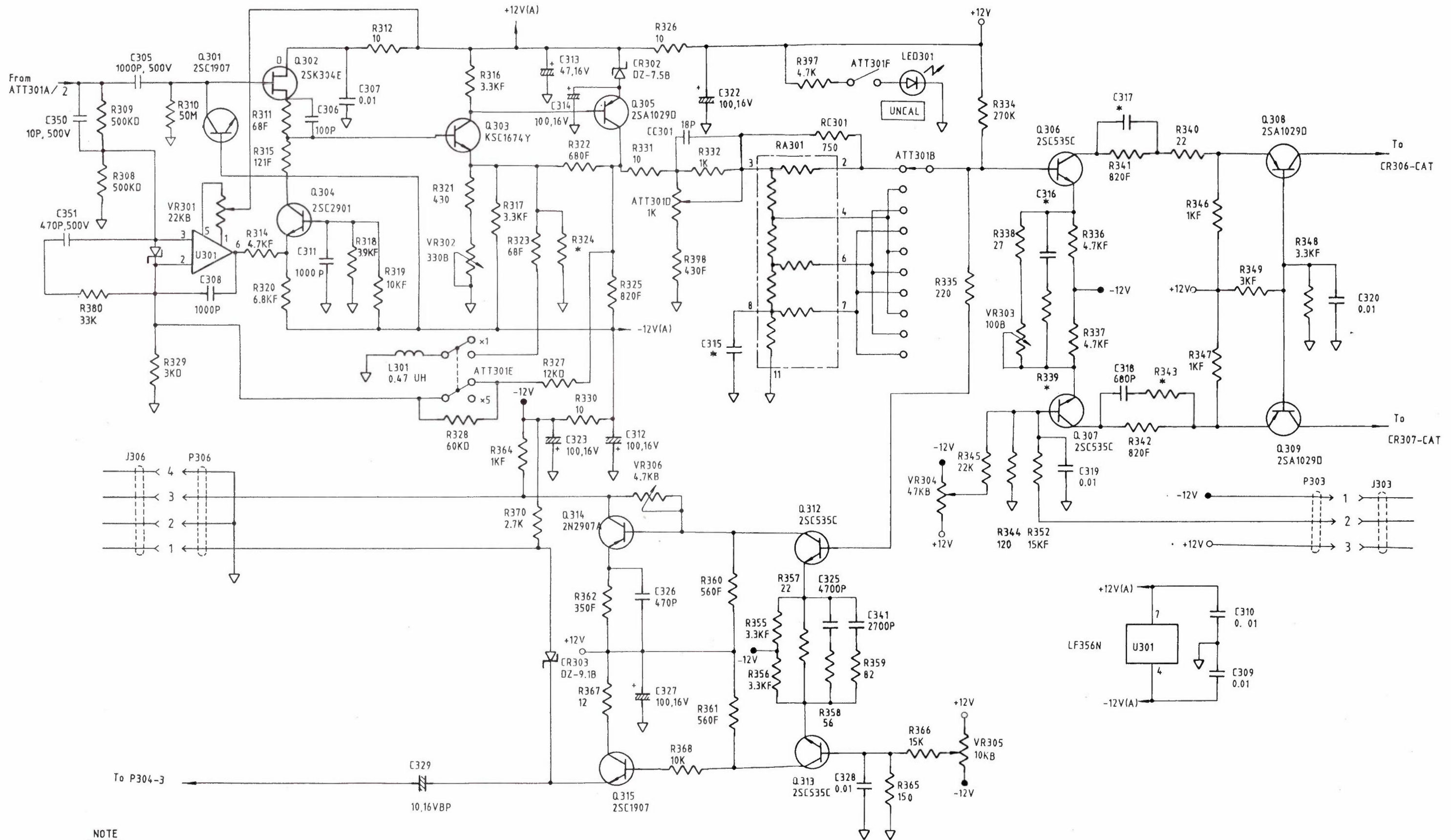

NOTE
 *: FACTORY SELECTED VALUE

CH1 INPUT(2)

CH2 INPUT AMP (3)

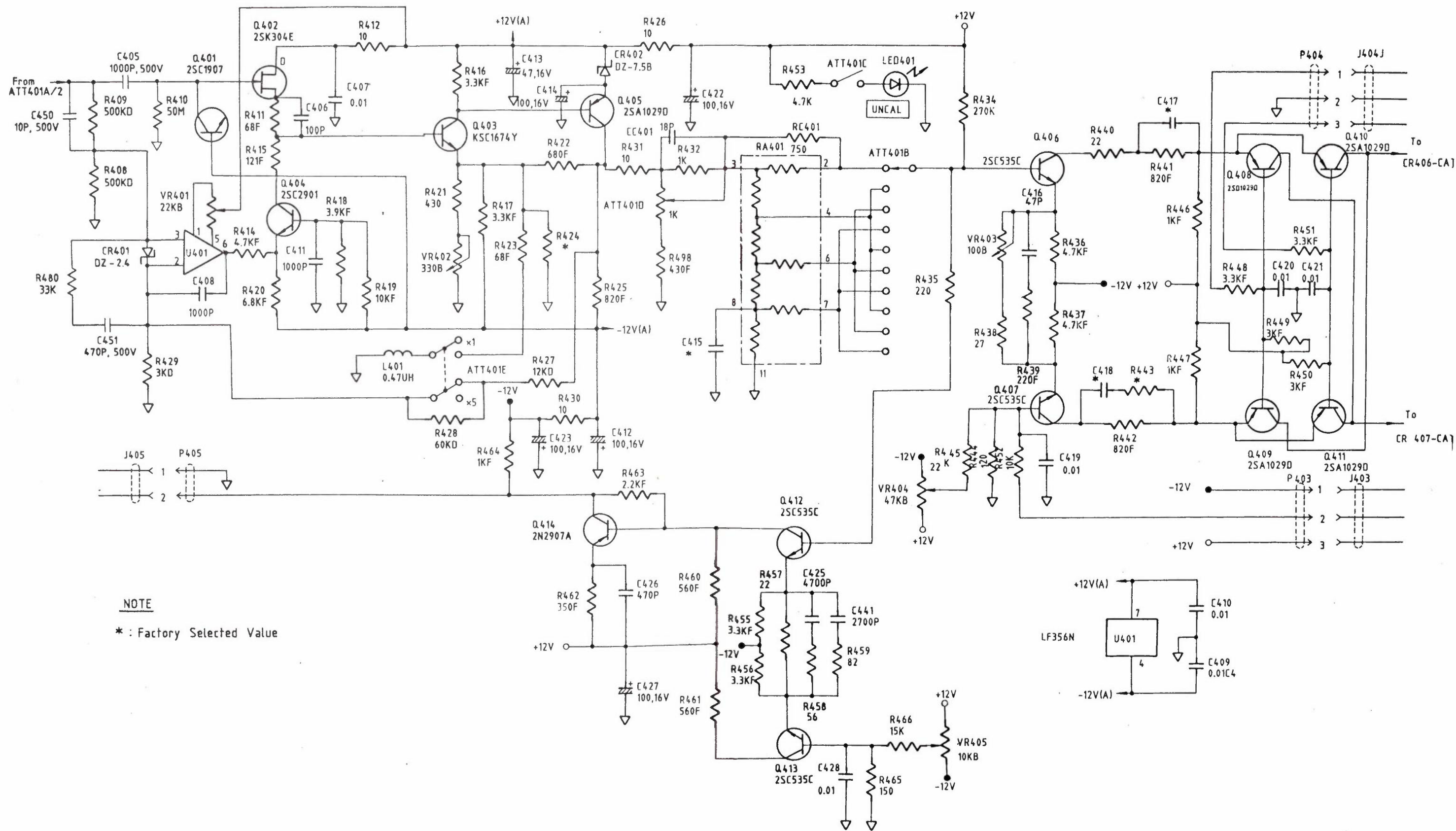

NOTE
 * : Factory Selected Value

VERTICAL CONTROL (4)

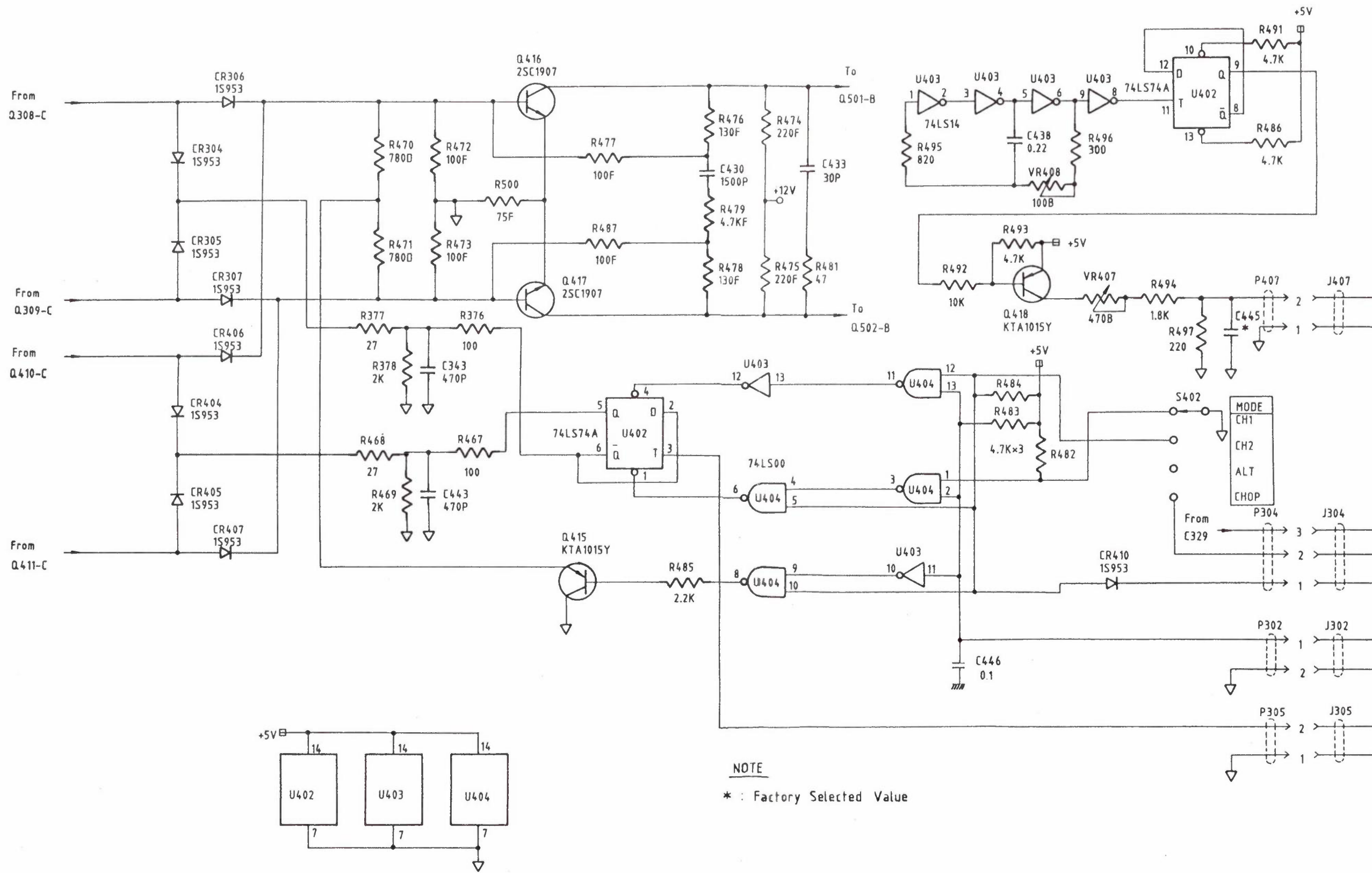

VERTICAL MAIN AMP (5)

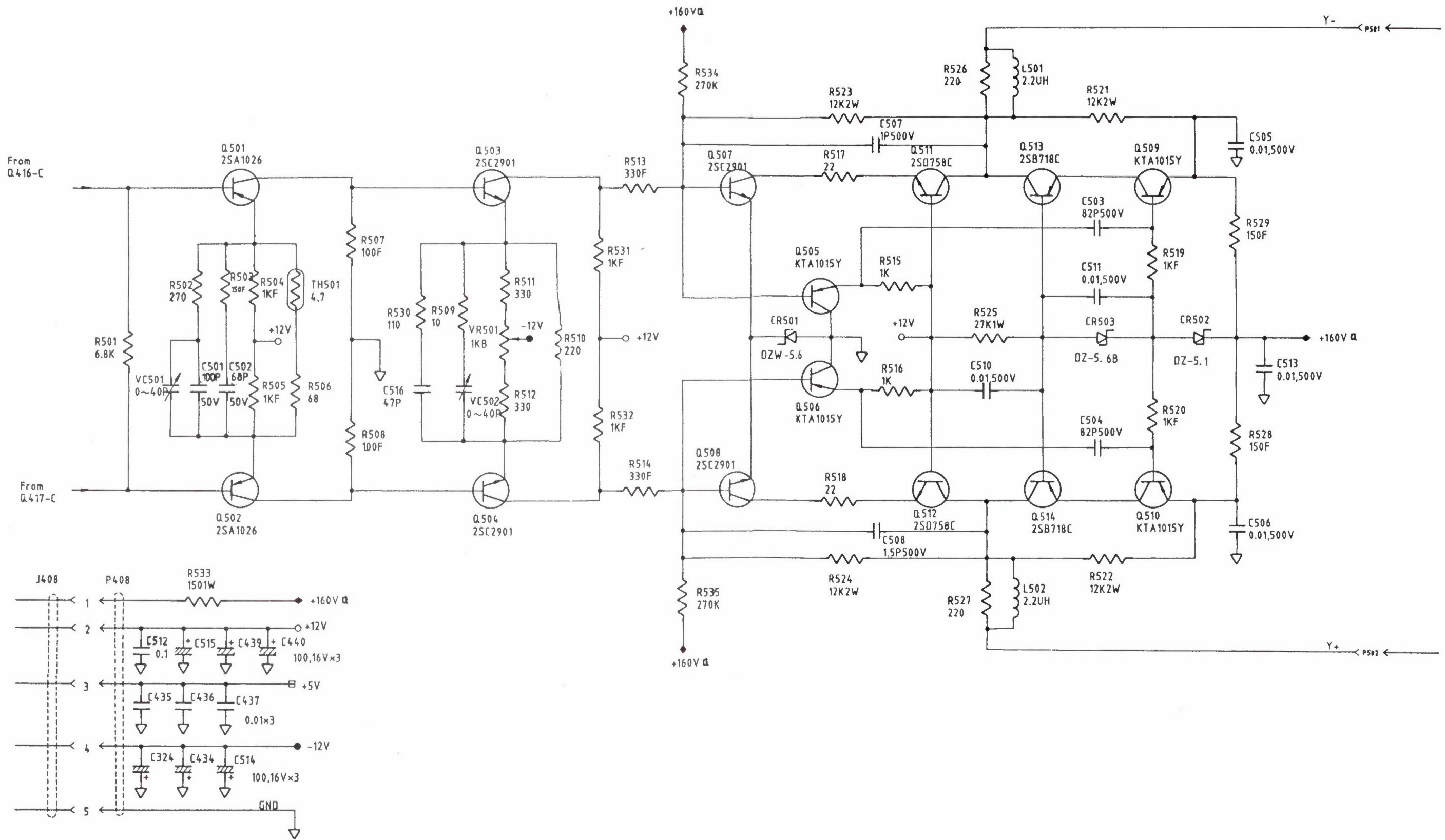

VERTICAL MAIN AMP(5)

TRIG - AMP (6)

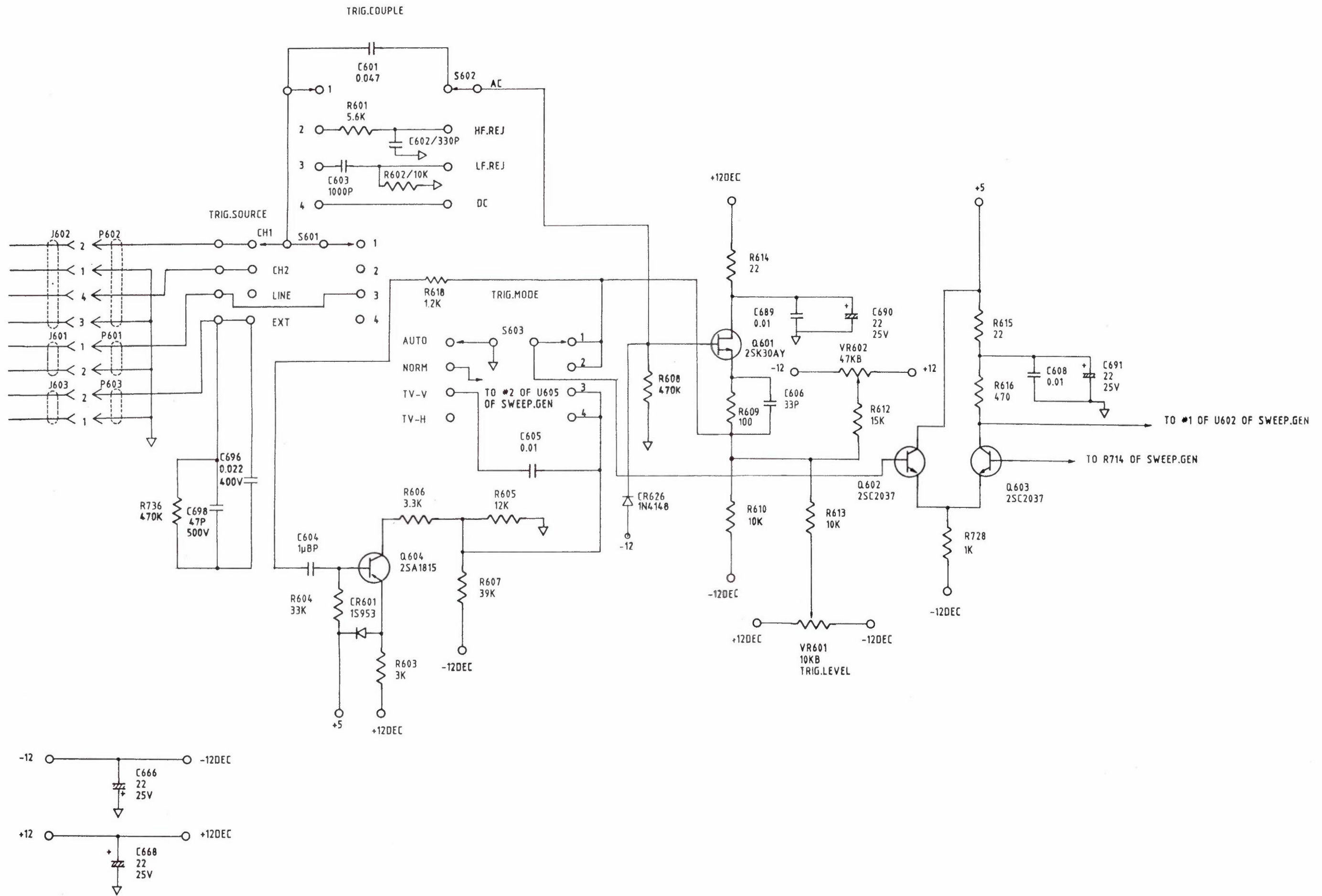

SWEEP GEN (7)

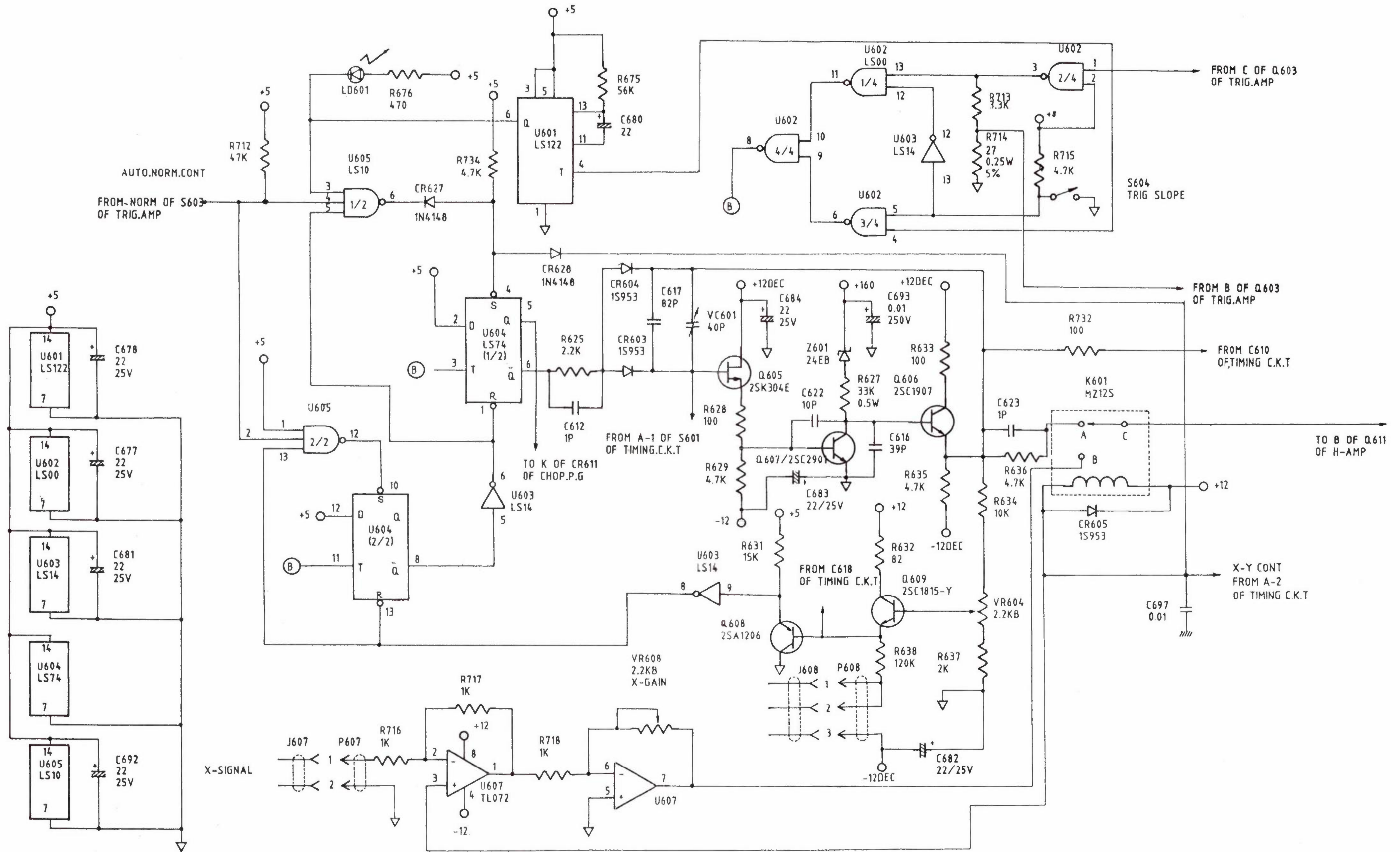

SWEEP GEN (7)

TIMING C.K.T (8)

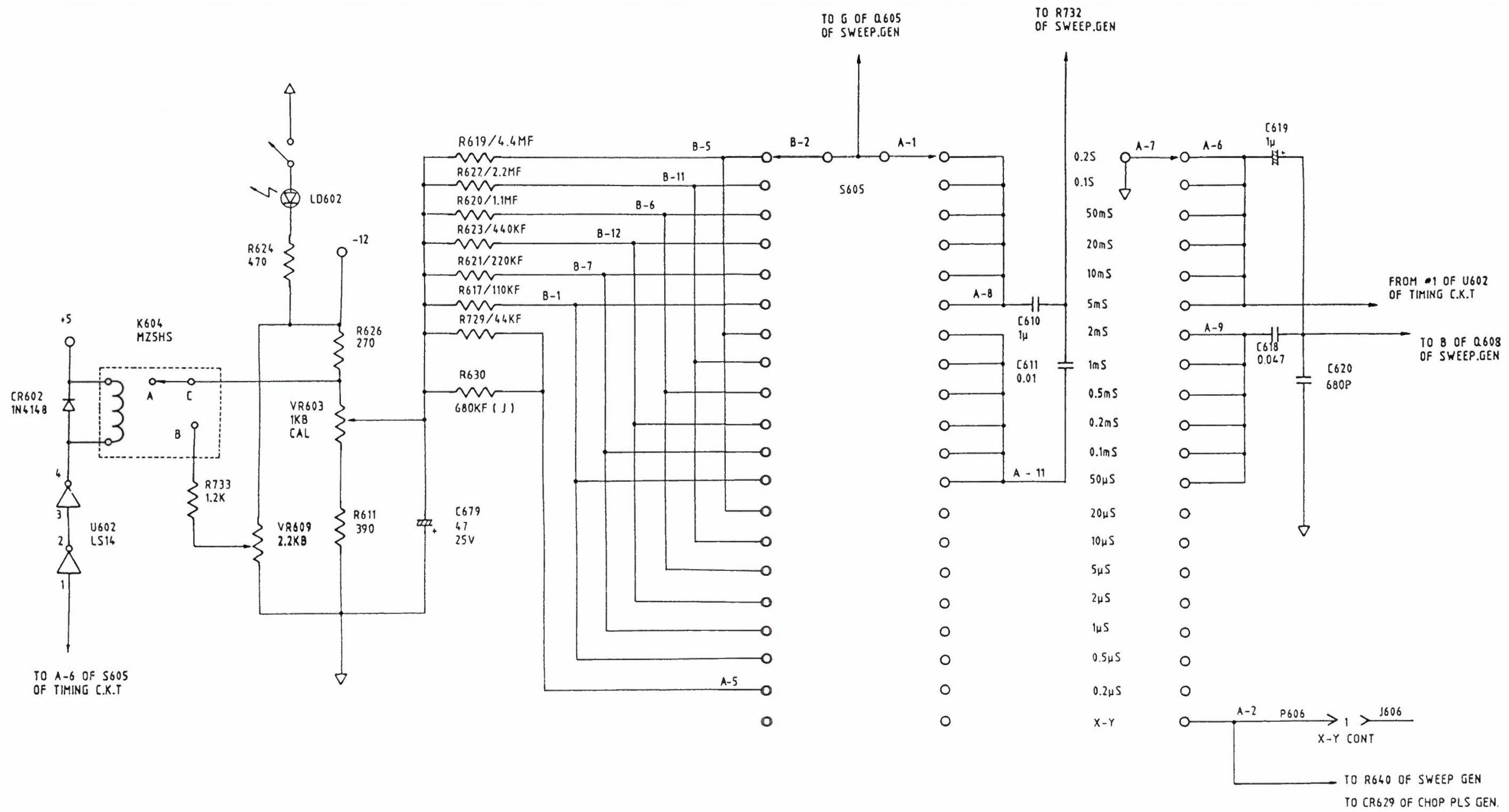

TIMING C.K.T(8)

H-MAIN AMP (9)

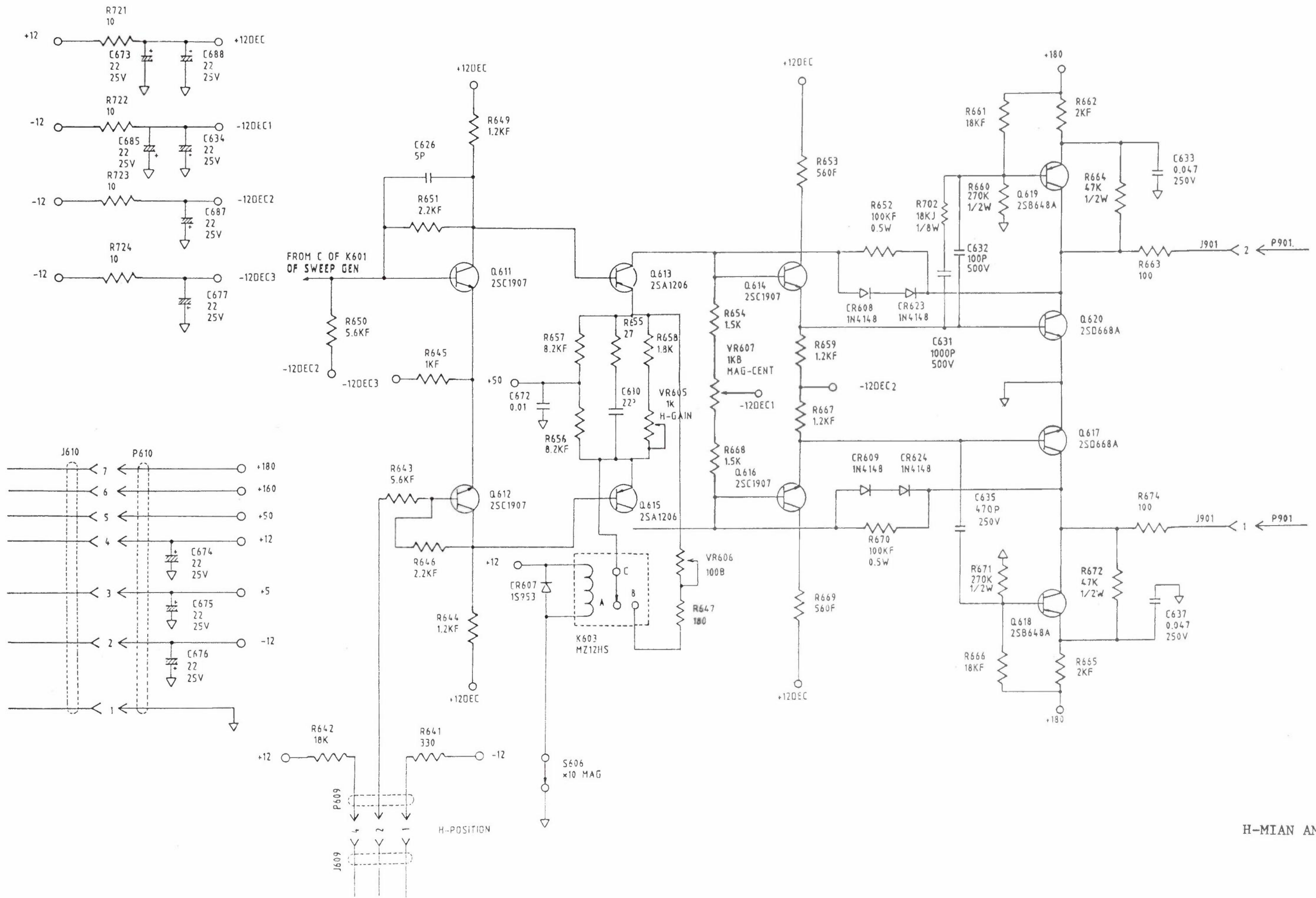

H-MIAN AMP (9)

CHOP PLS GEN (10)

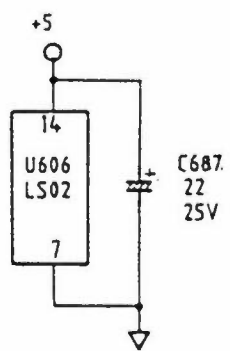
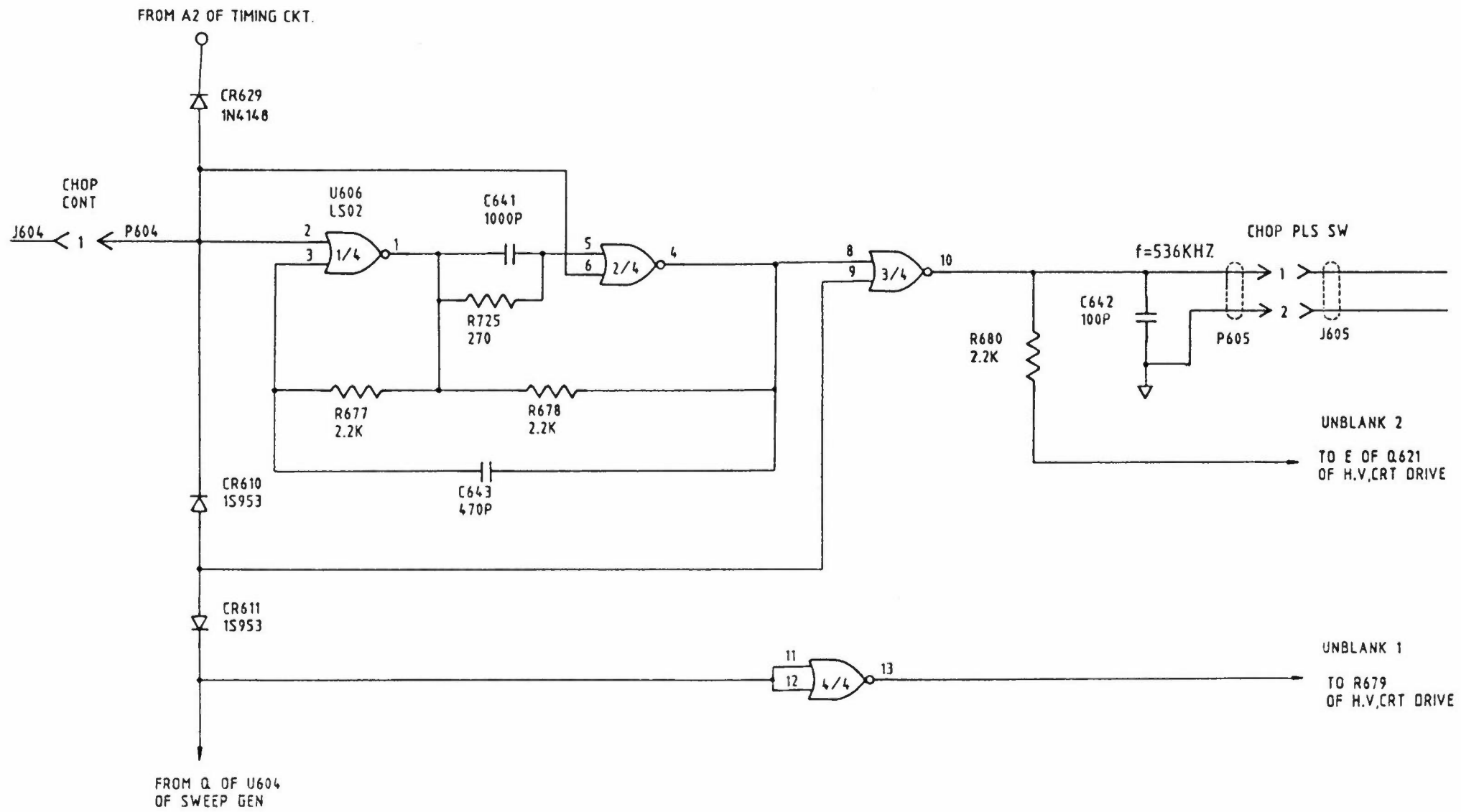

H.V. CRT DRIVE (11)

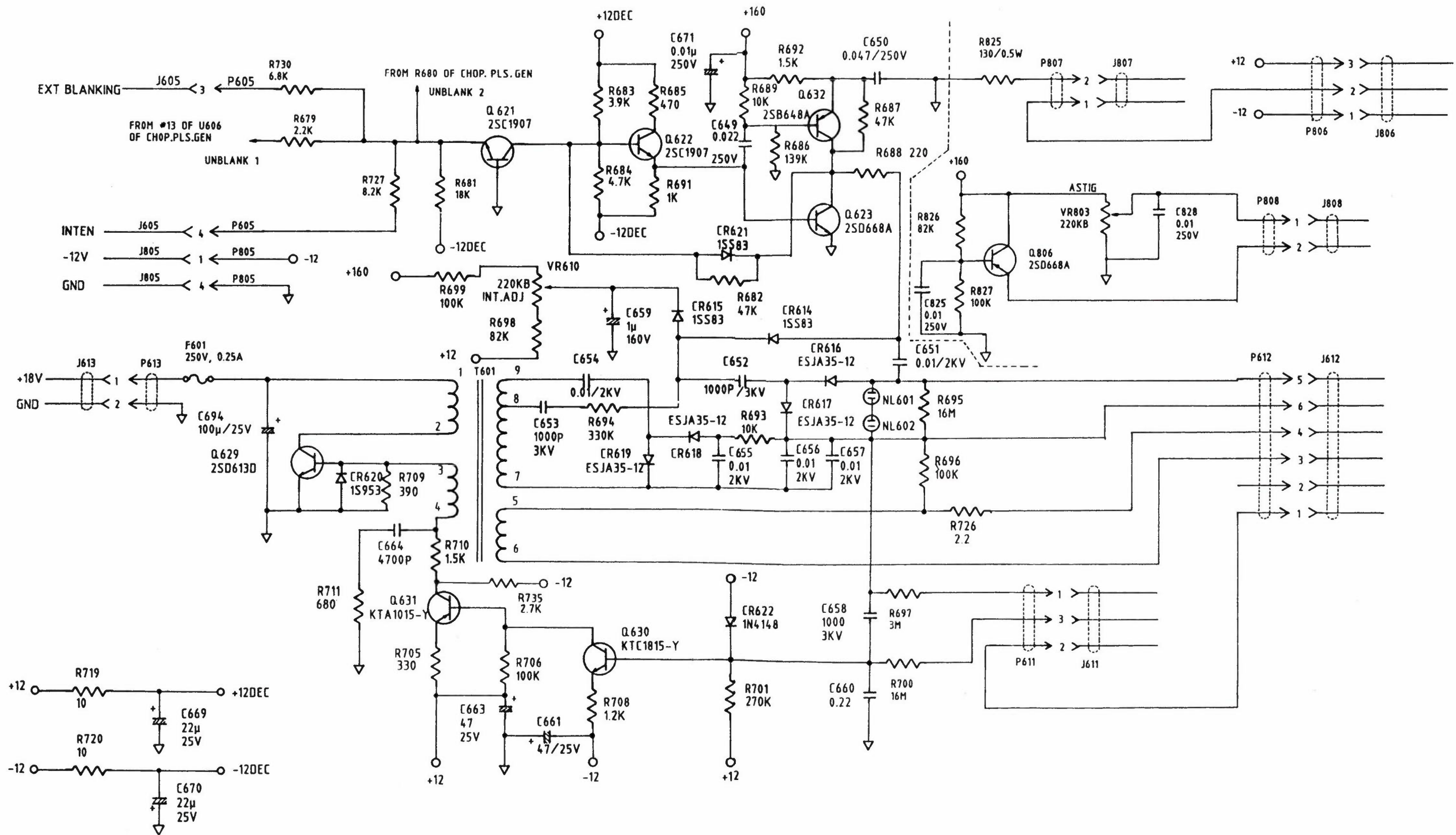

H.V CRT DRIVE(11)

POWER SUPPLY (12)

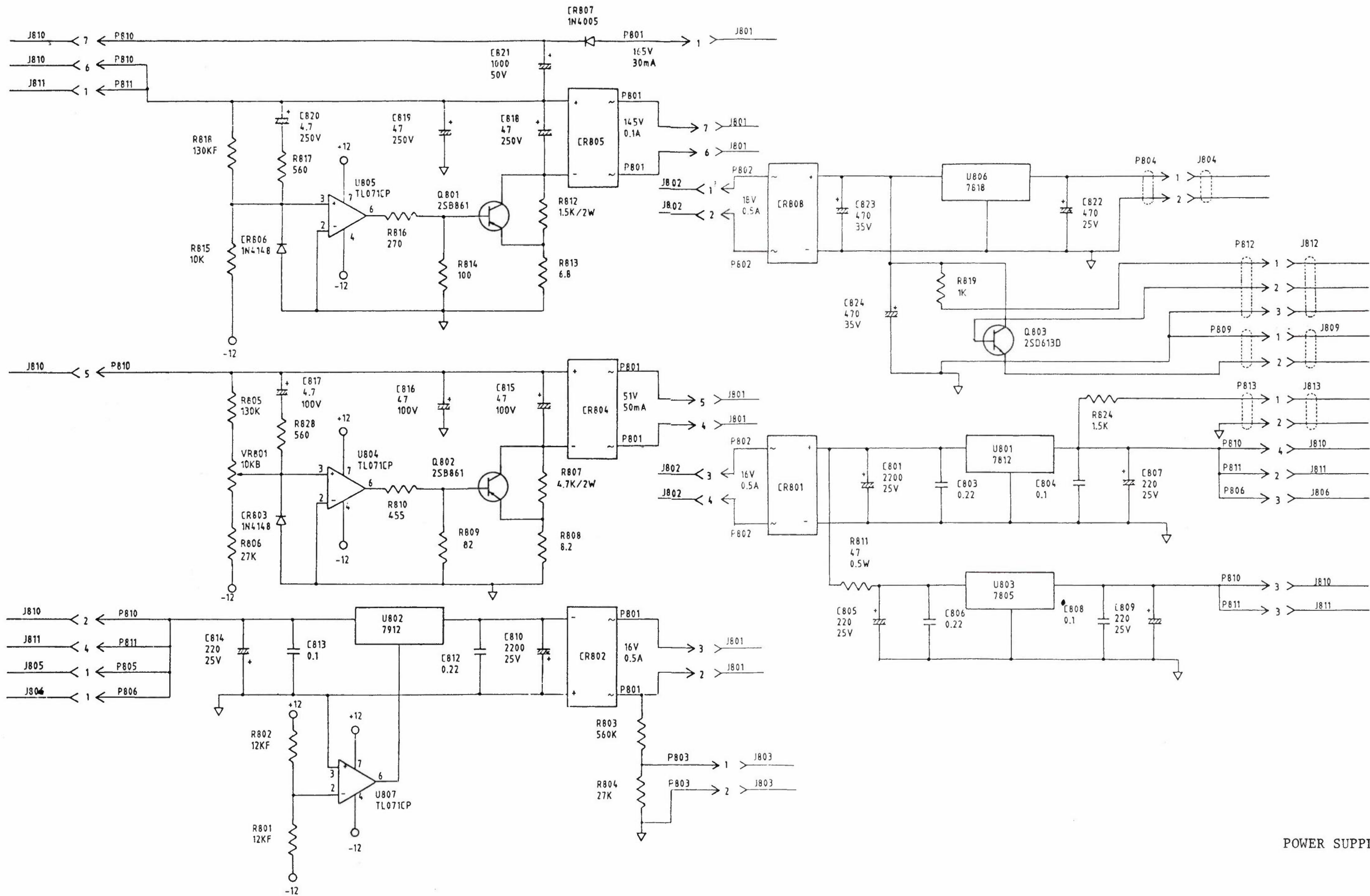

POWER SUPPLY(12)

WIRING DIAGRAM

14. WIRING DIAGRAM

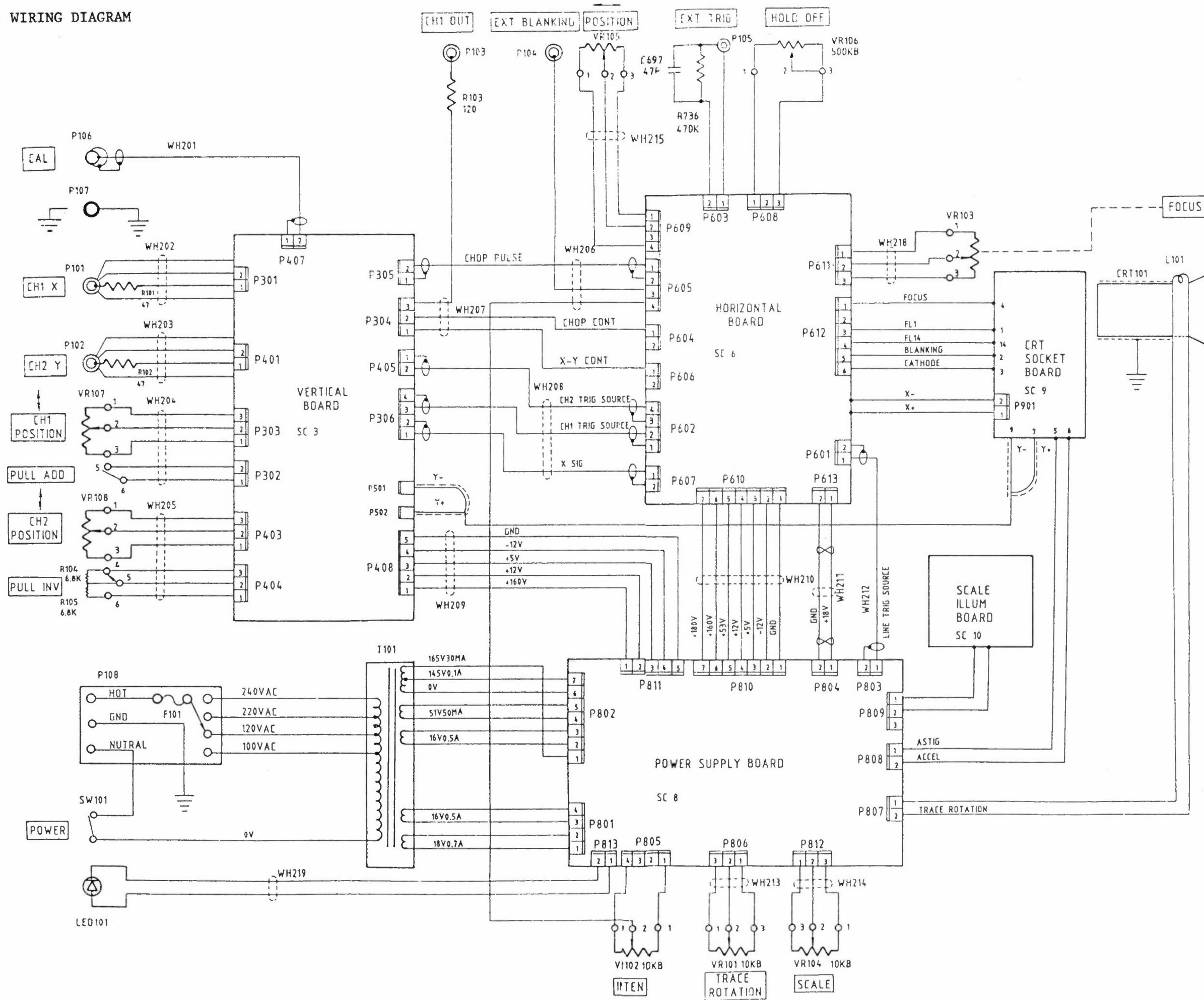

WIRING DIAGRAM

EXPLODED VIEW

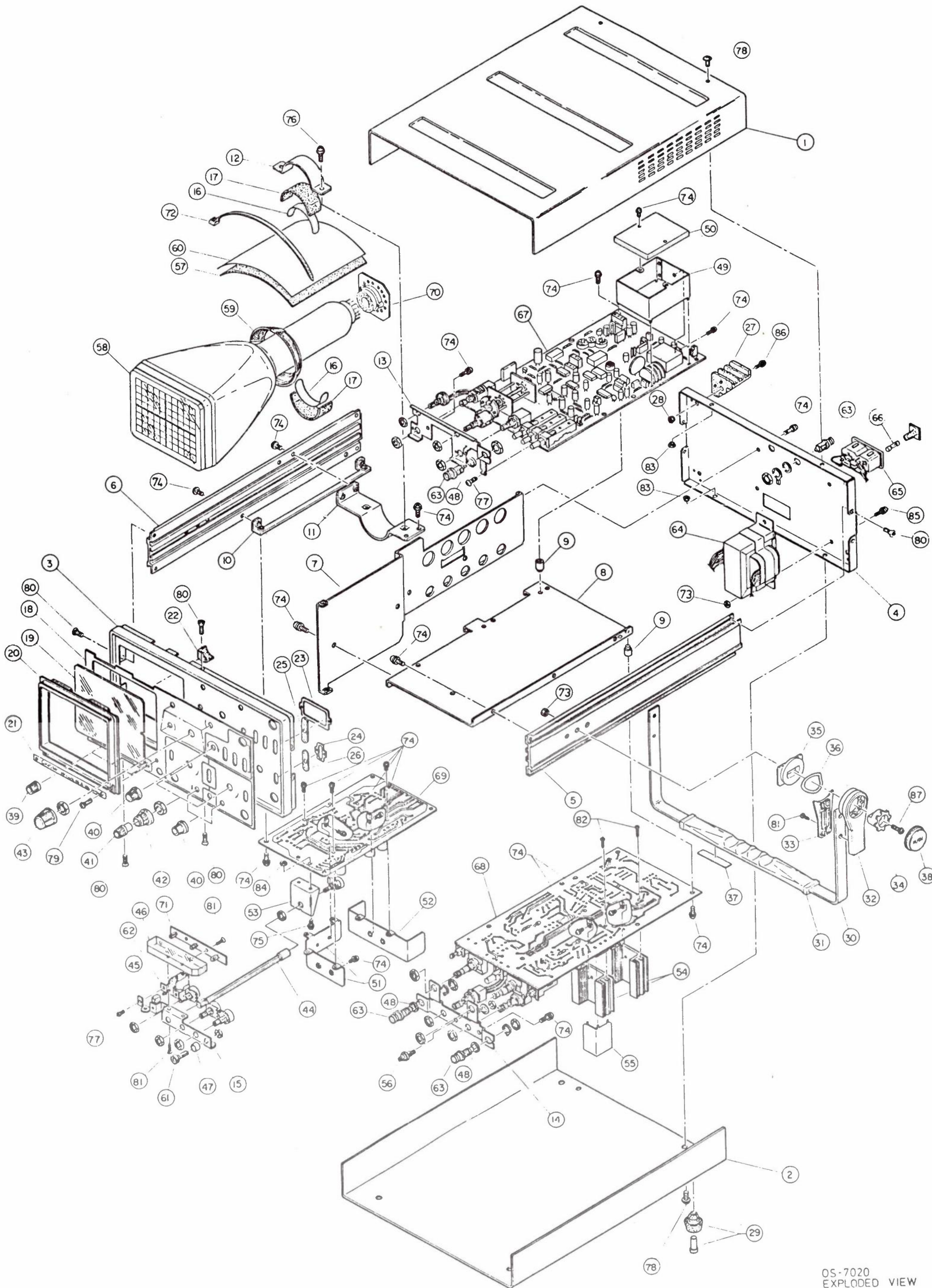

OS-7020
EXPLODED VIEW

15. MECHANICAL PARTS LIST AND EXPLODED VIEW

NO	PART NO.	DESC.	Q'TY	REMARK
1	219-152	COVER, TOP	1	
2	219-151	COVER, BOTTOM	1	
3	215-083	FRONT CASE	1	
4	247-087	REAR PANEL	1	
5	227-050	FRAME RIGHT	1	
6	227-051	FRAME LEFT	1	
7	242-214	PLATE, VERTICAL	1	
8	242-215	PLATE, HORIZONTAL	1	
9	363-073	SPACER	11	
10	235-194	BK'T, PCB MTG	1	
11	235-198	BASE, CRT MTG	1	
12	235-196	BK'T, CRT MTG	1	
13	235-193	BK'T, HORIZONTAL	1	
14	235-192	BK'T VERTICAL	1	
15	235-190	BK'T, CONTROL	1	
16	362-015	GND SPRING	2	
17	360-016	PAD, RUBBER	2	
18	247-088	FRONT PANEL	1	
19	587-032	FILTER	1	
20	354-006	HOOD	1	
21	277-639	LABEL	1	
22	265-012	BLOCK, CRT MTG	4	
23	341-020	RUBBER GUIDE I	1	
24	341-021	RUBBER GUIDE II	3	
25	358-046-1	RUBBER PLATE I	4	
26	358-046-2	RUBBER PLATE II	2	

NO	PART NO.	DESC.	Q'TY	REMARK
27	397-001	REAR FOOT	4	
28	313-051-2	PRESSNUT M4	4	
29	397-002	DOWN FOOT	4	
30	367-023	HANDLE	1	
31	367-025	HANDLE MOLDING	1	
32	347-001	ARM	2	
33	347-002	COVER, ARM	2	
34	335-002	BOSS	2	
35	387-009	FLANGE	2	
36	262-006	SPRING WASHER	2	
37	278-010	BADGE GOLDSTAR	1	
38	375-012	CAP	2	
39	369-046	KNOB 1	3	
40	369-047	KNOB 2	6	
41	369-048	KNOB 3	2	
42	369-049	KNOB 4	2	
43	369-050	KNOB 5	1	
44	374-002	EXTENSION ROD	1	
45	369-051	KNOB POWER	1	
46	242-216	ILLUMINATION PLATE	1	
47	317-046	WASHER, MTG. GND	1	
48	317-045	WASHER MTG. BNC	3	
49	215-084	OVEN CASE	1	
50	219-153	OVEN COVER	1	
51	566-061	HEATSINK I	2	
52	566-062	HEATSINK II	1	

NO	PART NO.	DESC.	Q'TY	REMARK
53	235-191	BK'T MTG FOCUS	1	
54	566-065	HEATSINK B-222	2	
55	235-197	SHIELD BK'T	1	
56	539-010	TERMINAL, CAL ASS'Y	1	
57	358-047	RUBBER CRT RAP	1	
58	631-007	C.R.T(105BTD31A)	1	
59	638-005	ROTION COIL	1	
60	873-023	U-MATER PLATE	1	
61	537-018	TERMINAL GND	1	
62	521-070	SWITCH POWER	1	
63	531-164	CONN. BNC-RS(UG-1094)	5	
64	622-016	TRANSFORMER	1	
65	531-170	AC INLET. GSS42R34	1	
66	563-035	FUSE 115V2A	1	
67	511-283-A	HORIZONTAL BOARD ASS'Y	1	
68	511-284-A	VERTICAL BOARD ASS'Y	1	
69	511-285-A	POWER SUPPLY B/D ASS'Y	1	
70	511-282-A	CRT SOCKET BOARD ASS'Y	1	
71	511-281-A	LAMP BOARD ASS'Y	1	
72	556-012	TIE WRAP	1	
73	NHB04-00U	NUT	2	
74	MPC03A06U	SCREW	4	
75	MPC03A08U	SCREW	2	
76	MPC03A12U	SCREW	2	
77	MPC03A06U	SCREW	3	
78	MTC03 -06P	TRUSS HEAD SCREW	4	

NO	PART NO.	DESC.	Q'TY	REMARK
79	MTC03 -08P	TRUSS HEAD SCREW	2	
80	MCC03A-06U	COUNTERSUNK HEAD SCREW	10	
81	TRM03 -06P	TAPPING SCREW	4	
82	TRM03 -15P	TAPPING SCREW	4	
83	313-051-1	PRESS NUT M3	4	
84	NHB03 -00U	NUT	2	
85	MPC04A12U	SCREW	2	
86	MPC04A16U	SCREW	4	
87	MPC04A18U	SCREW	2	



GoldStar Precision Co., Ltd.

20, Yeouido-dong, Yeongdongpo-gu, Seoul 150, Korea
19th Fl., East Tower, Lucky-Goldstar Twin Tower
Tel: 787-6848~57, Tlx: GSRADAR K22838 Fax: (02) 784-1646
Cable: GOLDRADAR

GoldStar Precision

13013 East 166th Street, Cerritos, Ca. 90701-2295 U.S.A.
Tel: (213) 404-0101, Tlx: (910) 583-5719LGILA
Fax: (213) 926-0849