

Engine & Cooling	Fuel	Ignition	Electrical	Running gear	Torque settings	Capacities	Notes & Illustrations
------------------	------	----------	------------	--------------	-----------------	------------	-----------------------



# Automotive Technical DATA BOOK

Click on one of the buttons above to view data for this car. To return to this screen and make another choice, click anywhere on the data screen.

MENU

HELP

## Engine and cooling system Croma 2000 CHT 1986 to 1989

Type		154 A1.000
Capacity (cm <sup>3</sup> ) / number of cylinders		1995 / 4
Compression ratio / pressure	bar	9.5 / _
Oil pressure	bar	[3.4 to 4.9]
Oil temperature	°C	100
Valve clearance - inlet	mm	0.35±0.04
Valve clearance - exhaust	mm	0.40±0.04
Firing order		1-3-4-2
No 1 cylinder position		TBE
Thermostat opening temperature	°C	81 to 85
Radiator cap pressure	bar	0.98

## Fuel system Croma 2000 CHT 1986 to 1989

Idle speed - manual [auto]	rpm	750±50
Fast idle speed - manual [auto]	rpm	_
CO @ idle speed [3000 rpm] - see page VI	%	1.0 to 2.0
HC @ idle speed [3000 rpm] - see page VI	ppm	≤1200
CO <sub>2</sub> @ idle speed [3000 rpm] - see page VI	%	_
O <sub>2</sub> @ idle speed [3000 rpm] - see page VI	%	_
Carburettor / fuel injection		Weber
Type / ref		34 DAT 54 / 250
Main jet / needle		100, 110
Injection pressure	bar	_
Pump pressure	bar	0.24 to 0.29
Octane rating	RON	98[R]

## Ignition system Croma 2000 CHT 1986 to 1989

Type		AEI
Ignition coil		Marelli BAE 207A
Primary resistance	ohms	0.75 to 0.81
Ballast resistor	ohms	_
Voltage - Tmnl 15(+) to earth	V	_
Distributor		Marelli
Points gap (air gap)	mm	_
Dwell angle	° (%)	_
Condenser capacity	µF	_
Rotation		_
Ignition timing - basic [static	° Crankshaft @ rpm	10 BTDC @ idle
V = Vacuum  NV = No Vacuum		NV
Total ignition advance	° Crankshaft @ rpm	_
	° Crankshaft @ rpm	_
	° Crankshaft @ rpm	_
Centrifugal check.	° Crankshaft @ rpm	0 to 4 @ 2100
	° Crankshaft @ rpm	8 to 12 @ 3000
	° Crankshaft @ rpm	13 to 17 @ 4500
Vacuum range check	mbar	67 to 427
Maximum vacuum advance	° Crankshaft	8 to 10
Spark plugs		Bosch/Champion
Type		WR6DC / RN7YC
Electrode gap	mm	0.60 to 0.70

## Electrical system Croma 2000 CHT 1986 to 1989

Battery	V / CC / RC	12 / 210 / 65
Alternator voltage / full load current / engine rpm		14.0 to 14.3 / _ / 3500
Starter motor current / voltage - cranking	A / V	270 / 9.2
- locked	A / V	_

## Running gear Croma 2000 CHT 1986 to 1989

<b>Brakes -</b>		
Front (min. friction material thickness)	mm	1.5
Rear (min. friction material thickness)	mm	1.5

<b>Tyres</b>		
Saloon	Size	175/70x14: 195/60x14
Estate / Van	Size	_
Pressure - front / rear - Saloon	bar	175: 2.0 / 2.0 <sup>1</sup>
- Estate / Van	bar	_

## Front suspension / wheel alignment

Toe-in (+) / Toe-out (-)	mm [°]	-1.0 to +1.0
Camber		-20'±20'
Castor		+2°30' to 3°10'
King pin inclination		_

## Rear suspension / wheel alignment

Toe-in (+) / Toe-out (-)	mm [°]	+2.0 to 5.0
Camber		-20'±20'

## Torque wrench settings Croma 2000 CHT 1986 to 1989

Cylinder head - stage 1	Nm	20
- stage 2	Nm	40
Cylinder head - stage 3	Nm	+ 90°
- stage 4	Nm	+ 90°
Big-end bearings	Nm	74
Main bearings	Nm	20 <sup>2</sup>
Clutch cover	Nm	20
Flywheel [driveplate]	Nm	142
Front hubs	Nm	360
Rear hubs	Nm	320
Wheel nuts / bolts	Nm	98
Spark plugs	Nm	25 to 30

## Capacities Croma 2000 CHT 1986 to 1989

Engine oil & filter	litres	5.5
Gearbox - 4-speed [5-speed]	litres	1.5 to 1.6
Automatic transmission - refill	litres	_
Final drive	litres	WT
Cooling system	litres	9.0
Fuel tank	litres	70

## Notes and Illustrations

<sup>1</sup>195: 2.2 / 2.2  
<sup>2</sup>Centre bearing: + 120°. Others: + 80°

1: Idle speed    2: CO / Mixture

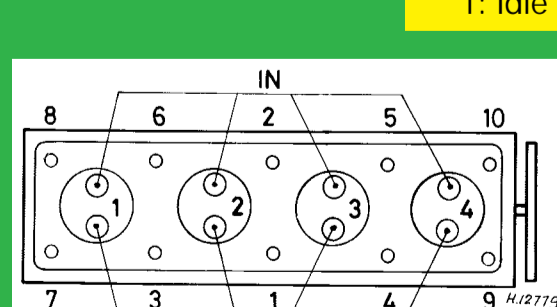

1995 cm<sup>3</sup>, 8V

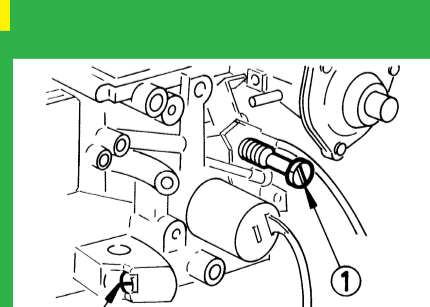

Weber DAT