

| | | | | | | | |
|------------------|------|----------|------------|--------------|-----------------|------------|-----------------------|
| Engine & Cooling | Fuel | Ignition | Electrical | Running gear | Torque settings | Capacities | Notes & Illustrations |
|------------------|------|----------|------------|--------------|-----------------|------------|-----------------------|



Automotive Technical DATA BOOK

Click on one of the buttons above to view data for this car. To return to this screen and make another choice, click anywhere on the data screen.

MENU **HELP**

Engine and cooling system Maverick 2.4i 1993 to 1996

| | | |
|---|-----------------------------|--------------|
| Type | KA24E. BF. 91kW. 91/441/EEC | |
| Capacity (cm ³) / number of cylinders | 2389 / 4 | |
| Compression ratio / pressure | bar | 8.6 / 13.24 |
| Oil pressure | bar | [4.1 to 4.8] |
| Oil temperature | °C | 80 |
| Valve clearance - inlet | mm | 0: Hyd. |
| Valve clearance - exhaust | mm | 0: Hyd. |
| Firing order | 1-3-4-2 | |
| No 1 cylinder position | TCE | |
| Thermostat opening temperature | °C | 76.5 |
| Radiator cap pressure | bar | 0.78 to 0.98 |

Fuel system Maverick 2.4i 1993 to 1996

| | | |
|---|---------|--------------|
| Idle speed - manual [auto] | rpm | 800±50 |
| Fast idle speed - manual [auto] | rpm | — |
| CO @ idle speed [3000 rpm] - see page VI | % | — |
| HC @ idle speed [3000 rpm] - see page VI | ppm | — |
| CO ₂ @ idle speed [3000 rpm] - see page VI | % | — |
| O ₂ @ idle speed [3000 rpm] - see page VI | % | — |
| Carburettor / fuel injection | — | |
| Type / ref | PCM EFI | |
| Main jet / needle | — | |
| Injection pressure | bar | 2.26 to 2.94 |
| Pump pressure | bar | — |
| Octane rating | RON | 91[U] |

Ignition system Maverick 2.4i 1993 to 1996

| | | |
|---------------------------------|--------------------|------------------|
| Type | Computerized | |
| Ignition coil | — | |
| Primary resistance | ohms | — |
| Ballast resistor | ohms | — |
| Voltage - Tmnl 15(+) to earth | V | — |
| Distributor | — | |
| Points gap (air gap) | mm | — |
| Dwell angle | ° (%) | — |
| Condenser capacity | µF | — |
| Rotation | — | |
| Ignition timing - basic [static | ° Crankshaft @ rpm | 10±2 BTDC @ ≤850 |
| V = Vacuum NV = No Vacuum | — | |
| Total ignition advance | ° Crankshaft @ rpm | Computer control |
| Centrifugal check. | ° Crankshaft @ rpm | Computer control |
| Vacuum range check | mbar | Computer control |
| Maximum vacuum advance | ° Crankshaft | — |
| Spark plugs | _/Champion | |
| Type | RN9YCC | |
| Electrode gap | mm | 0.80 |

Electrical system Maverick 2.4i 1993 to 1996

| | | |
|---|--------------------|---|
| Battery | V / CC / RC | — |
| Alternator voltage / full load current / engine rpm | 14 / 60, 65, 70/ _ | |
| Starter motor current / voltage - cranking | A / V | — |
| - locked | A / V | — |

Running gear Maverick 2.4i 1993 to 1996

| | | |
|---|-----------------|----------------------|
| Brakes - | | |
| Front (min. friction material thickness) | mm | 2.0 |
| Rear (min. friction material thickness) | mm | 2.0 |
| Tyres | | |
| Saloon | Size | — |
| Estate / Van | Size | 215/80x15: 235/75x15 |
| Pressure - front / rear - Saloon | bar | — |
| - Estate / Van | bar | 3D: 1.8 / 2.2' |
| Front suspension / wheel alignment | | |
| Toe-in (+) / Toe-out (-) | mm [°] | +3.0 to 5.0 |
| Camber | 0 to +1° | |
| Castor | +1°10' to 2°10' | |
| King pin inclination | +7°36' to 8°36' | |
| Rear suspension / wheel alignment | | |
| Toe-in (+) / Toe-out (-) | mm [°] | — |
| Camber | — | |

Torque wrench settings Maverick 2.4i 1993 to 1996

| | | |
|-------------------------|----|------------------|
| Cylinder head - stage 1 | Nm | 29 |
| - stage 2 | Nm | 78 |
| Cylinder head - stage 3 | Nm | - 360° (slacken) |
| - stage 4 | Nm | 29 + 83° |
| Big-end bearings | Nm | 15 + 63° |
| Main bearings | Nm | 49 |
| Clutch cover | Nm | 26 |
| Flywheel [driveplate] | Nm | 147 |
| Front hubs | Nm | WSM |
| Rear hubs | Nm | WSM |
| Wheel nuts / bolts | Nm | 123 |
| Spark plugs | Nm | 25 |

Capacities Maverick 2.4i 1993 to 1996

| | | |
|---------------------------------|--------|--------------------|
| Engine oil & filter | litres | 4.3 |
| Gearbox - 4-speed [5-speed] | litres | 3.5. Transfer: 2.3 |
| Automatic transmission - refill | litres | — |
| Final drive | litres | Rear: 2.8 |
| Cooling system | litres | 6.9 |
| Fuel tank | litres | 3D: 72. 5D: 80 |

Notes and Illustrations

5D: 1.9 / 2.5

1: Idle speed 2: CO / Mixture

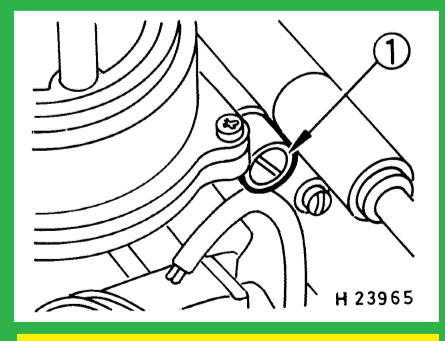
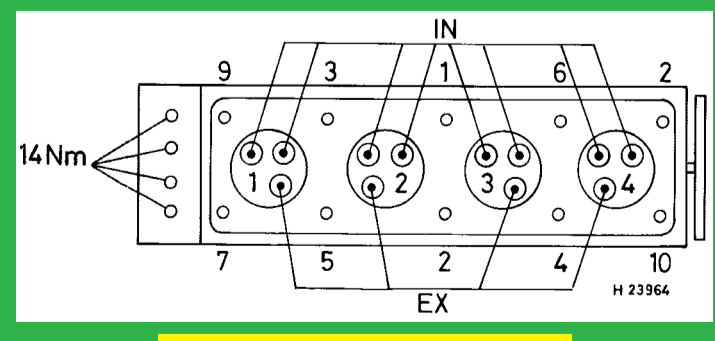

2389 cm³, 12V

PCM EFI