

Engine & Cooling	Fuel	Ignition	Electrical	Running gear	Torque settings	Capacities	Notes & Illustrations
------------------	------	----------	------------	--------------	-----------------	------------	-----------------------



Automotive Technical DATA BOOK

Click on one of the buttons above to view data for this car. To return to this screen and make another choice, click anywhere on the data screen.

MENU

HELP

Engine and cooling system 205, 1.4 XS, SR, GT 1990 to 1992

Type	TU3S (K2A) (62kW)	
Capacity (cm ³) / number of cylinders	1360 / 4	
Compression ratio / pressure	bar	9.3 / _
Oil pressure	bar	1.5 [3.0]
Oil temperature	°C	80
Valve clearance - inlet	mm	0.20
Valve clearance - exhaust	mm	0.40
Firing order	1-3-4-2	
No 1 cylinder position	FE	
Thermostat opening temperature	°C	88
Radiator cap pressure	bar	1.0

Fuel system 205, 1.4 XS, SR, GT 1990 to 1992

Idle speed - manual [auto]	rpm	750±50
Fast idle speed - manual [auto]	rpm	_
CO @ idle speed [3000 rpm] - see page VI	%	1.0 to 2.0
HC @ idle speed [3000 rpm] - see page VI	ppm	≤1200
CO ₂ @ idle speed [3000 rpm] - see page VI	%	≥9.0
O ₂ @ idle speed [3000 rpm] - see page VI	%	_
Carburettor / fuel injection	Solex	
Type / ref	32-34 Z2 409	
Main jet / needle	117, 130	
Injection pressure	bar	_
Pump pressure	bar	0.25
Octane rating	RON	97[E 95 RON]

Ignition system 205, 1.4 XS, SR, GT 1990 to 1992

Type	Electronic	
Ignition coil	_	
Primary resistance	ohms	0.7
Ballast resistor	ohms	_
Voltage - Tmnl 15(+) to earth	V	_
Distributor	Bosch	
Points gap (air gap)	mm	_
Dwell angle	° (%)	_
Condenser capacity	µF	_
Rotation	Anticlockwise	
Ignition timing - basic [static	° Crankshaft @ rpm	4 BTDC @ 750
V = Vacuum NV = No Vacuum	NV	
Total ignition advance	° Crankshaft @ rpm	C052-D039
	° Crankshaft @ rpm	_
	° Crankshaft @ rpm	_
Centrifugal check.	° Crankshaft @ rpm	8 to 13 @ 1400
	° Crankshaft @ rpm	18 to 22 @ 2200
	° Crankshaft @ rpm	30 to 34 @ 6400
Vacuum range check	mbar	160 to 320
Maximum vacuum advance	° Crankshaft	9 to 12
Spark plugs	Eyquem/Champion	
Type	FC58LS / C7YCX	
Electrode gap	mm	0.80

Electrical system 205, 1.4 XS, SR, GT 1990 to 1992

Battery	V / CC / RC	12 / 175 / 60
Alternator voltage / full load current / engine rpm	13.8 to 14.8 / _ / 3000	
Starter motor current / voltage - cranking	A / V	_
- locked	A / V	_

Running gear 205, 1.4 XS, SR, GT 1990 to 1992

Brakes -		
Front (min. friction material thickness)	mm	1.0
Rear (min. friction material thickness)	mm	_

Tyres		
Saloon	Size	165/70x13
Estate / Van	Size	_
Pressure - front / rear - Saloon	bar	1.8 / 2.0
- Estate / Van	bar	_

Front suspension / wheel alignment

Toe-in (+) / Toe-out (-)	mm [°]	+1.0±0.5 PW
Camber		0±30'
Castor		+3°±30'
King pin inclination		+9°45'±30'

Rear suspension / wheel alignment

Toe-in (+) / Toe-out (-)	mm [°]	+1.7±0.8 PW
Camber		-50'±30'

Torque wrench settings 205, 1.4 XS, SR, GT 1990 to 1992

Cylinder head - stage 1	Nm	20
- stage 2	Nm	+ 240°
Cylinder head - stage 3	Nm	_
- stage 4	Nm	_
Big-end bearings	Nm	40
Main bearings	Nm	WSM
Clutch cover	Nm	15
Flywheel [driveplate]	Nm	65 LkC
Front hubs	Nm	265
Rear hubs	Nm	215
Wheel nuts / bolts	Nm	85
Spark plugs	Nm	28

Capacities 205, 1.4 XS, SR, GT 1990 to 1992

Engine oil & filter	litres	3.5
Gearbox - 4-speed [5-speed]	litres	2.0
Automatic transmission - refill	litres	_
Final drive	litres	WT
Cooling system	litres	5.8
Fuel tank	litres	50

Notes and Illustrations

1: Idle speed 2: CO / Mixture

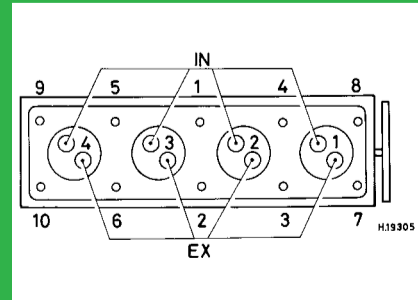

1360 cm³, TU3

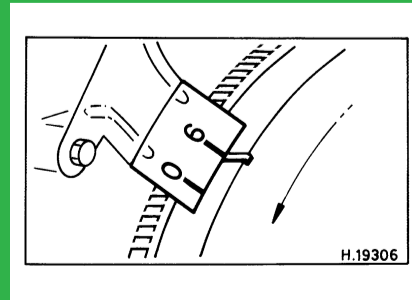

1360 cm³, TU3

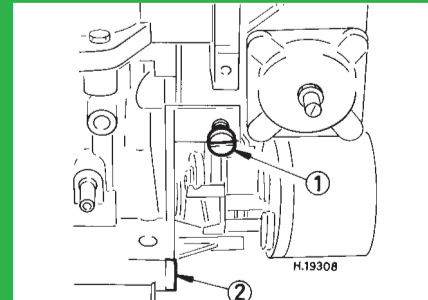

Solex Z2