

Engine & Cooling	Fuel	Ignition	Electrical	Running gear	Torque settings	Capacities	Notes & Illustrations
------------------	------	----------	------------	--------------	-----------------	------------	-----------------------

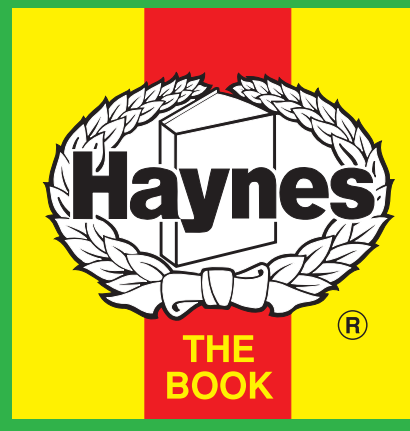

Automotive Technical DATA BOOK

Click on one of the buttons above to view data for this car. To return to this screen and make another choice, click anywhere on the data screen.

MENU

HELP

Engine and cooling system

740, 2.3i 1988 to 1991

Type	B230E. SOHC 8V. 96kW	
Capacity (cm ³) / number of cylinders	2316 / 4	
Compression ratio / pressure	bar	10.3 / ≥8.8
Oil pressure	bar	[2.5 to 8.0]
Oil temperature	°C	80
Valve clearance - inlet	mm	0.30 to 0.40
- exhaust	mm	0.30 to 0.40
Firing order	1-3-4-2	
No 1 cylinder position	TBE	
Thermostat opening temperature	°C	87 to 97 or 92 to 102
Radiator cap pressure	bar	1.5

Fuel system

740, 2.3i 1988 to 1991

Idle speed - manual [auto]	rpm	900±50
Fast idle speed - manual [auto]	rpm	—
CO @ idle speed [3000 rpm] - see page VI	%	1.0-0.5+1.0
HC @ idle speed [3000 rpm] - see page VI	ppm	≤1200
CO ₂ @ idle speed [3000 rpm] - see page VI	%	—
O ₂ @ idle speed [3000 rpm] - see page VI	%	—
Carburettor / fuel injection	Bosch	
Type / ref	CIS (K-Jetronic)	
Main jet / needle	—	
Injection pressure	bar	3.5 to 4.0
Pump pressure	bar	4.4 to 5.2
Octane rating	RON	95[E 95 RON]

Ignition system

740, 2.3i 1988 to 1991

Type	EZ118K	
Ignition coil	Bosch	
Primary resistance	ohms	0.6 to 0.8
Ballast resistor	ohms	—
Voltage - Tmnl 15(+) to earth	V	—
Distributor	Bosch	
Points gap (air gap)	mm	—
Dwell angle	° (%)	—
Condenser capacity	µF	—
Rotation	Clockwise	
Ignition timing - basic [static	° Crankshaft @ rpm	12 BTDC @ 900±50
V = Vacuum NV = No Vacuum	NV	
Total ignition advance	° Crankshaft @ rpm	27 to 31 @ 2500
	° Crankshaft @ rpm	—
	° Crankshaft @ rpm	—
Centrifugal check.	° Crankshaft @ rpm	Computer control
	° Crankshaft @ rpm	—
	° Crankshaft @ rpm	—
Vacuum range check	mbar	Computer control
Maximum vacuum advance	° Crankshaft	—
Spark plugs	Bosch/Champion	
Type	WR6DC / RN7YC	
Electrode gap	mm	0.70 to 0.80

Electrical system

740, 2.3i 1988 to 1991

Battery	V / CC / RC	12 / 450 / 90
Alternator voltage / full load current / engine rpm	13.8 to 14.6 / _ / 3000	
Starter motor current / voltage - cranking	A / V	1.1kW: 70 / 11.5 ¹
- locked	A / V	1.1kW: 480 to 560 / 7.4 ²

Running gear

740, 2.3i 1988 to 1991

Brakes -		
Front (min. friction material thickness)	mm	3.0
Rear (min. friction material thickness)	mm	2.0
Tyres		
Saloon	Size	185/65x15
Estate / Van	Size	185/65x15
Pressure - front / rear - Saloon	bar	1.9 / 1.9
- Estate / Van	bar	1.9 / 2.1
Front suspension / wheel alignment		
Toe-in (+) / Toe-out (-)	mm [°]	+3.5±1.0
Camber	-0.2° to +0.8°	
Castor	+4.5° to 5.5°	
King pin inclination	—	
Rear suspension / wheel alignment		
Toe-in (+) / Toe-out (-)	mm [°]	+2.0±3.0
Camber	WSM	

Torque wrench settings

740, 2.3i 1988 to 1991

Cylinder head - stage 1	Nm	20
- stage 2	Nm	60
- stage 3	Nm	+ 90°
- stage 4	Nm	—
Big-end bearings	Nm	20 + 90°
Main bearings	Nm	110
Clutch cover	Nm	—
Flywheel [driveplate]	Nm	70 N
Front hubs	Nm	100 + 45°
Rear hubs	Nm	WSM
Wheel nuts / bolts	Nm	85
Spark plugs	Nm	25

Capacities

740, 2.3i 1988 to 1991

Engine oil & filter	litres	3.9
Gearbox - 4-speed [5-speed]	litres	1.6
Automatic transmission - refill	litres	2.0
Final drive	litres	1.6
Cooling system	litres	8.5
Fuel tank	litres	60

Notes and Illustrations

¹1.4kW: 75 / 11.5. 2kW: 65 to 95 / 11.5. Hitachi: 300 / 8.8

²1.4kW: 625 to 800 / 4.5. 2kW: 700 to 880 / 4.5. Hitachi: 880 / 3

1: Idle speed 2: CO / Mixture

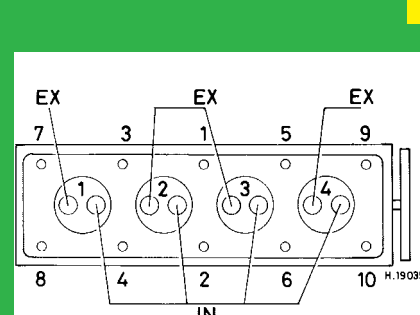
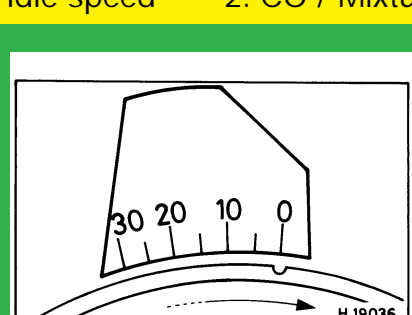
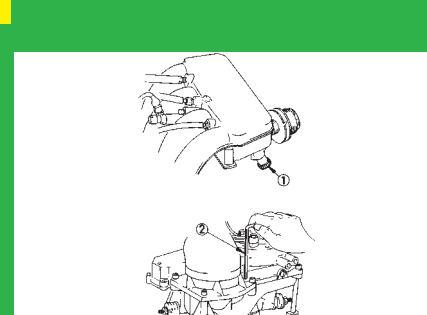
2316 cm³, 8V2316 cm³, 8V

K-Jetronic