

CHAPTER 28



ENGINE BALANCING AND BALANCE SHAFTS

OBJECTIVES

After studying Chapter 28, the reader will be able to:

1. Prepare for Engine Repair (A1) ASE certification test content area "C" (Engine Block Diagnosis and Repair).
2. Explain the causes of primary and secondary engine vibration.
3. Describe why balance shafts are used.
4. Explain what parts are rotating weight and what parts are reciprocating weight.
5. List the steps needed to balance an engine.

KEY TERMS

Dampening (p. 547)

Primary Vibration (p. 547)

Rocking Couple (p. 547)

Secondary Vibration (p. 547)

ENGINE BALANCE

Anything that rotates will vibrate. This means that an engine will vibrate during operation, although engine designers attempt to reduce the vibration as much as possible. When pistons move up and down in the cylinders they create a **primary vibration**, which is a strong low-frequency vibration.

A counterweight on the crankshaft opposite the piston/rod assembly helps reduce this vibration. An inline 4-cylinder engine has very little primary vibration because as two pistons are traveling upward in the cylinders, two are moving downward at the same time, effectively canceling out primary unbalances. See Figure 28-1.

Four-cylinder engines, however, suffer from a vibration at twice engine speed. This is called a **secondary vibration**, which is a weak high-frequency vibration caused by a slight difference in the inertia of the pistons at top dead center compared to bottom dead center. This vibration is most noticeable at high-engine speeds, especially if the engine size is greater than 2.0 liters. The larger the displacement of the engine, the larger the bore and the heavier the pistons contribute to the buzzing-type secondary vibration. See Figure 28-2.

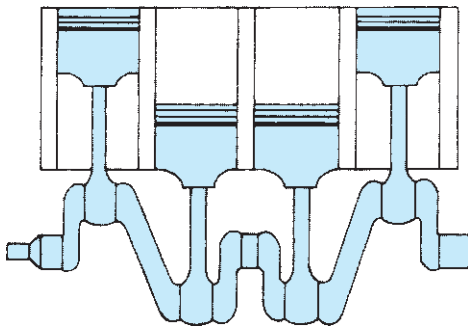

FIGURE 28-1 In a 4-cylinder engine, the two outside pistons move upward at the same time as the inner pistons move downward, which reduces primary unbalance.

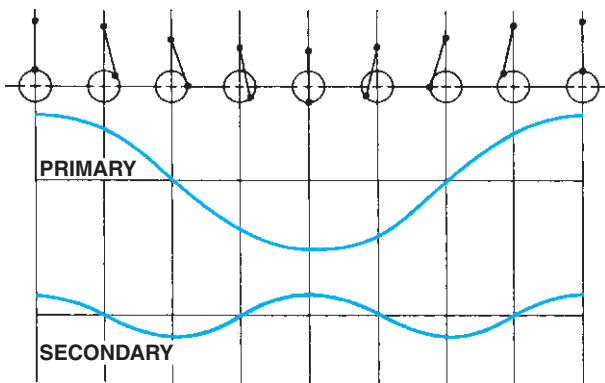

FIGURE 28-2 Primary and secondary vibrations in relation to piston position.

BALANCE SHAFTS

Some engines use balance shafts to dampen normal engine vibrations. **Dampening** is reducing the vibration to an acceptable level. A balance shaft that is turning at crankshaft speed, but in the opposite direction, is used on a 3-cylinder inline engine. Weights on the ends of the balance shaft move in a direction opposite to the direction of the end piston. When the piston goes up, the weight goes down, and when the piston goes down, the weight goes up. This reduces the end-to-end rocking action on the 3-cylinder inline engine.

Another type of balance shaft system is designed to counterbalance vibrations on a 4-stroke, 4-cylinder engine. Two shafts are used, and they turn at *twice* the engine speed. One shaft turns in the same direction as the crankshaft, and the other turns in the opposite direction. The oil pump gears are used to drive the reverse-turning shaft. Counterweights on the balance shafts are positioned to oppose the natural rolling action of the engine, as well as the secondary vibrations caused by the piston and rod movements. This design is shown in Figure 28-3.

Balance shafts are commonly found on the larger-displacement (over 2.0 liter) 4-cylinder automotive engines. Mitsubishi introduced counterbalance shafts on 4-cylinder engines in 1974. Since the late 1980s, both Ford and General Motors added a balance shaft to many of their V-6 engines. These 90-degree V-6 engines use a split-crank journal to create an even-firing arrangement, but these engines suffer from forces that cause the engine to rock back and forth. This motion is called a **rocking couple** and is dampened by the use of

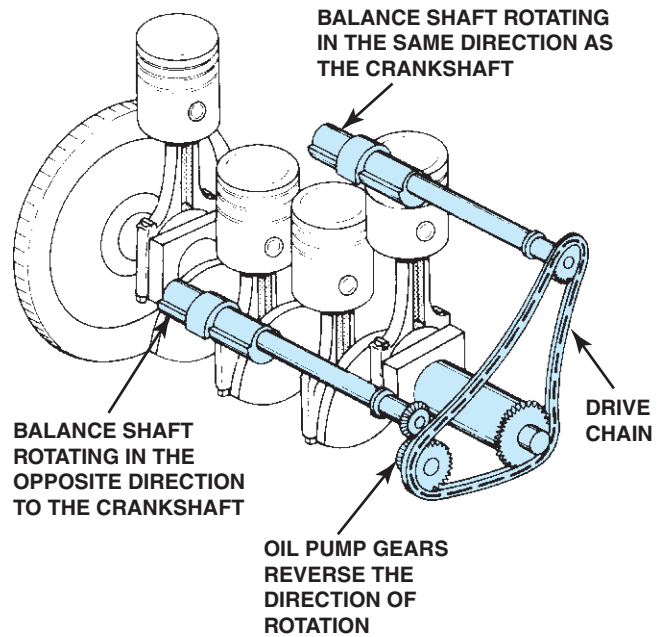

FIGURE 28-3 Two counter-rotating balance shafts used to counterbalance the vibrations of a 4-cylinder engine.

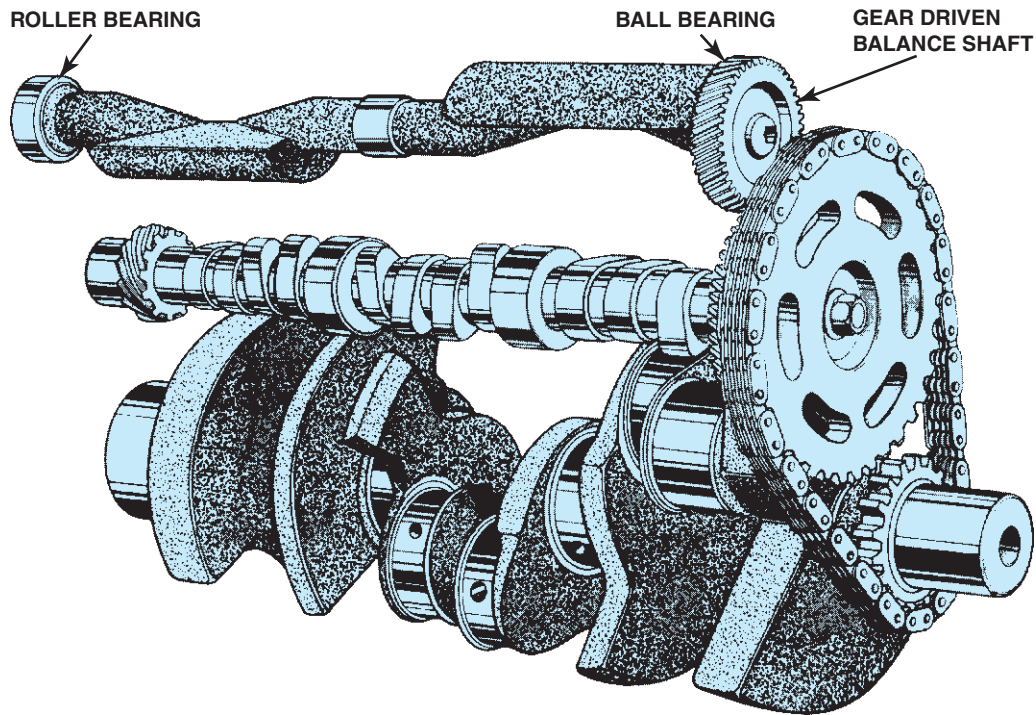

FIGURE 28-4 Many 90-degree V-6 engines use a balance shaft to reduce vibrations and effectively cancel a rocking motion (rocking couple) that causes the engine to rock front to back.

a balance shaft. Other V-6 engines that use a 60-degree V-6 engine do not create a rocking couple and, therefore, do not need a balance shaft. See Figure 28-4. The addition of balance shafts makes a big improvement in the smoothness of the engine. In V-6 engines, the improvement is most evident during idling and low-speed operation, whereas in the 4-cylinder engines, balance shafts are especially helpful at higher engine speeds.

BALANCING AN ENGINE

For any engine to operate with a minimum amount of vibration, all of the reciprocating parts must be close to the same weight. Production engines use parts that are usually within 3 grams of each other and result in a relatively smooth operating engine.

NOTE: A gram is 1/28 of an ounce or the weight of a typical small paper clip.

Custom engine builders attempt to get all reciprocating parts to 1 gram or less. The reason for such accuracy is that any unbalance is increased greatly by centrifugal force as the engine operates. The force of the unbalance increases by the square of the speed. In other words, if the engine RPM doubles, the force of any unbalance is multiplied by four. An unbalance of

1 ounce that is 1 inch from the center of rotation becomes a force of 7 ounces at 500 RPM. At 5000 RPM, this same 1 ounce of unbalance would be increased to 44 pounds.

Engine Balancing Procedure

All rotating and reciprocating parts of an engine are balanced. Before the engine can be balanced, all of the following parts are needed:

- Crankshaft
- Vibration damper (harmonic balancer)
- Flywheel or flex plate
- Pressure plate
- All bolts, lock washers, keys, and spacers needed to assemble the above parts on the crankshaft
- Connecting rods
- Pistons
- Wrist pins

To balance a V-type engine, the following additional parts are needed:

- Rod bearings
- Piston rings
- Wrist pin locks (if full-floating piston pins)

The first step is to equalize the *reciprocating mass*, which includes the pistons and rods. Reciprocating weight is also called *inertia weight*. The pistons should be weighed, including the piston pin and rings, to determine the lightest. Material should be ground from the heavier pistons until they match the weight of the lightest piston. Material should be removed from the weight balancing pads.

CAUTION: Do not grind or attempt to remove weight from the piston pin. This could weaken a highly stressed part and could lead to engine failure.

Connecting rods have a big end and a small end. The big end of the rod is considered to be part of the rotating weight and the small end part of the reciprocating weight after the rod has been reconditioned. The two ends should be weighed and matched separately. See Figure 28-5.

After all of the rods have been weighed, then material should be removed from the balancing pads of the heavier rods until they match the lightest rods. See Figure 28-6.

Bob Weights

Bob weights are attached to the rod journals on V-type engines to simulate the weight of the rods and pistons. See Figure 28-7. The bob weight must equal the total of the following for each journal:

- Rotating weight
- A percentage of the reciprocating weight
- An amount for the weight of the oil trapped between the journal and the bearing. The rotating weight includes the big end of the connecting rod and the connecting rod bearings.



FIGURE 28-5 Weighing the big end of a connecting rod on a scale that keeps it perfectly horizontal so that each end can be weighed separately.

NOTE: On V-8 engines, two rods share a crankpin so that the calculations for bob weight, including the weight of both big ends of the connecting rods and bearings, should be taken into consideration.

The reciprocating weight includes the small end of the rod(s) and the piston assemblies, which include the rings, pin, and locks, if equipped.

Balancing Factor

A balancing factor is a formula used to determine what percentage (usually 50%) of the reciprocating weight needs to be included in the bob weight. Most balancing machines



FIGURE 28-6 Removing material from the balancing pad on the small end of the rod to match it to the weight of the small end of the lightest rod being used in the engine.

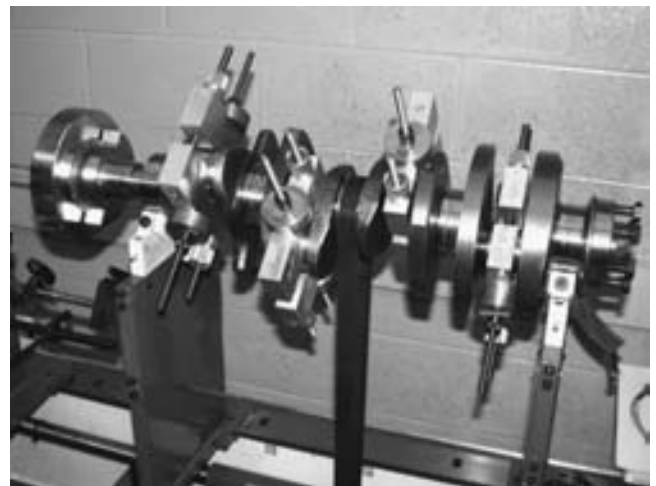

FIGURE 28-7 A crankshaft with bob weights attached.

calculate the bob weight automatically after inputting all of the weight information and then display where and how much material needs to be removed to achieve proper balance. See Figure 28-8.

A drill is commonly used to remove weight from the counterweight of the crankshaft to achieve proper balance. See Figure 28-9. After the specified material has been removed, the counterweight is checked again by the balance machine. When the procedure has been completed, the *rotating assembly* is then in balance.

Sometimes weight has to be added to a crankshaft to achieve proper balance. In this case, a hole is drilled parallel to the crankshaft in a counterweight and extra heavy metal is added.



FIGURE 28-8 The display of a crankshaft balancer showing where weight needs to be removed to achieve a balanced assembly.



FIGURE 28-9 A drill is usually used to remove weight from the crankshaft to achieve proper balance.

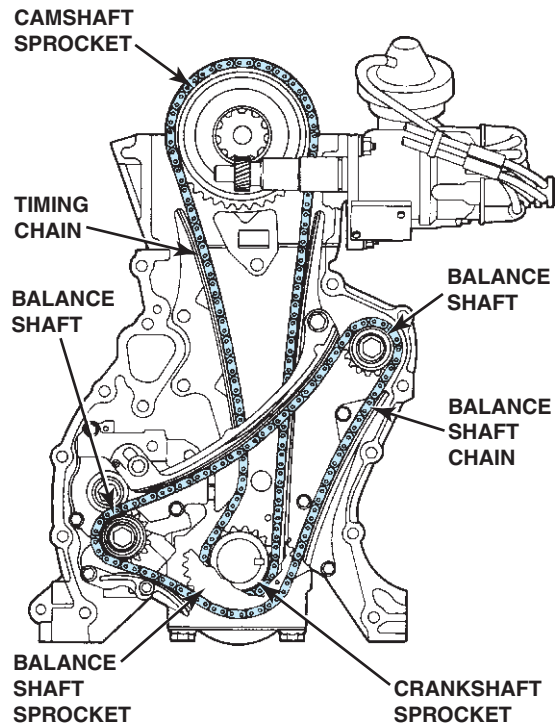

FIGURE 28-10 Worn balance shaft bearings and chains can be the cause of a noisy engine.



TECH TIP

NOISY ENGINE? CHECK THE CHAINS

Some 4-cylinder engines use multiple chains to drive the overhead camshafts and balance shafts. See Figure 28-10. If any one of these chains has stretched, it can cause noise as it hits the chain guide. Bearings for the balance shafts are also a common cause of engine noise.



FREQUENTLY ASKED QUESTION

WHAT IS "HEAVY METAL?"

Heavy metal, also called Mallory metal, is a tungsten steel alloy that is one and half times heavier than lead. It is used to add weight to a crankshaft if needed usually on engines that have been stroked using a stroker crankshaft. The heavy metal must be installed parallel to the centerline axis of the crankshaft.

ROD WEIGHING Step-by-Step



STEP 1

The equipment needed to weigh connecting rods includes the scale and the connecting rod big-end and small-end holding fixtures.



STEP 2

Before starting, double-check that all rods have been reconditioned and that the bolts and nuts are replaced, if necessary.



STEP 3

Start the weighing process by weighing the fixture used to hold the small end of the rod and then set the scale to zero.



STEP 4

Select the proper-size holding fixture for the big end of the rod.



STEP 5

Insert the big end of the rod into the holding fixture and place the small end on the scale.



STEP 6

Read and record the weight of the small end of the rod.

(continued)

ROD WEIGHING **continued**



STEP 7 Install the big-end fixture on the scale.



STEP 8 Set the scale to zero, which disregards the weight of the holding fixture. The weight of the holding fixture is called the tare weight.



STEP 9 Weigh the big end of the rod.



STEP 10 Record all weights from all connecting rods to be used in the engine. Compare the readings and determine where weight must be removed to make all rods weigh the same as the lightest rod in the set.



STEP 11 Use a grinder to remove material from the small-end or big-end balancing pad to achieve the proper weight.



STEP 12 Remeasure the weight of the rod after grinding.

CRANKSHAFT BALANCING Step-by-Step



STEP 1

Before the crankshaft can be checked for balance, the crankshaft has to be installed onto the balancer and the sensor at the end adjusted to eliminate any runout.



STEP 2

The bearings on which the crankshaft rides must be properly lubricated.



STEP 3

All necessary dimensions and weights are entered into the balancer and the balancer itself does the necessary calculations.



STEP 4

After the correct bob weights have been attached to the rod bearing journals and all necessary preliminary steps have been completed, the balancer is turned on and the crankshaft is spun.



STEP 5

After the crankshaft stops spinning, the balancer displays the amount of weight (in grams) that should be removed and its location.



STEP 6

An air-powered die grinder is being used to remove a small amount of weight from the crankshaft in the location specified by the balancer.

(continued)

CRANKSHAFT BALANCING continued

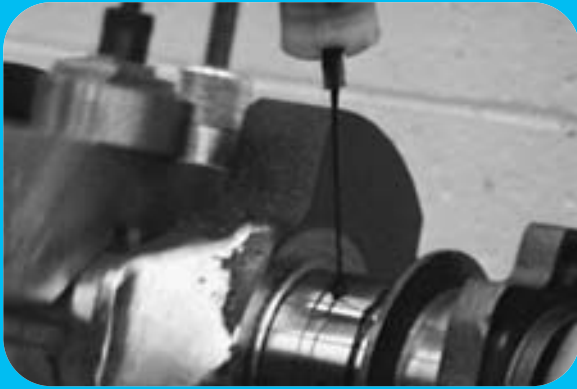

STEP 7

Before spinning the crankshaft to recheck the balance, the rubbing blocks are again lubricated.



STEP 8

The crankshaft is spun again to check the balance after material has been removed.



STEP 9

A small amount of additional material is being removed using a hand grinder.

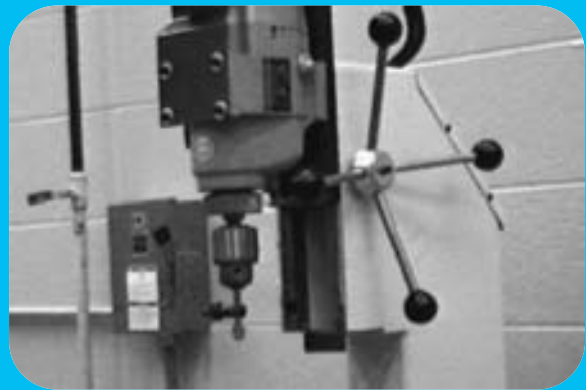

STEP 10

If more weight needs to be removed, the balancer is programmed to direct the technician as to how deep to drill into the counterweight and with which diameter drill bit.



STEP 11

This counterweight has been drilled to reduce its weight. The bigger the diameter and the deeper the hole is drilled, the more weight is removed from the crankshaft counterweight.



STEP 12

After weight has been drilled or ground from the crankshaft, the display will indicate that it is within acceptable balance tolerance.

SUMMARY

1. Primary vibration is a strong low-frequency vibration caused by the movement of the piston traveling up and down in the cylinder.
2. Secondary vibration is created by the slight differences in the inertia of the pistons between top dead center and bottom dead center.
3. Balance shafts are used to counteract vibration created in the engine.
4. Proper balancing of the engine is important for smooth operation.
5. Both rotating weight and reciprocating weight are considered during the balancing procedure.

REVIEW QUESTIONS

1. Why is a balance shaft needed on some V-6 engines?
2. What parts must be measured when measuring rotating weight?
3. What parts must be measured when measuring reciprocating weight?
4. What is done to the crankshaft to achieve a balanced rotating engine assembly?

CHAPTER QUIZ

1. What part(s) primarily causes primary vibration?
 - a. Harmonic balancer
 - b. Pistons
 - c. Flex plate
 - d. Big end of the connecting rod
2. What part(s) primarily causes secondary vibration?
 - a. Harmonic balancer
 - b. Pistons
 - c. Flex plate
 - d. Big end of the connecting rod
3. Why does a 4-cylinder engine have very little, if any, primary vibration?
 - a. A 4-cylinder engine uses a splayed crankshaft.
 - b. A 4-cylinder engine has two pistons traveling upward at the same time two pistons are traveling downward, thereby canceling primary vibration.
 - c. Two cylinders fire at the same time, reducing the primary vibration.
 - d. The bore of 4-cylinder engines is small, reducing the primary vibration.
4. A balance shaft used in a 90-degree V-6 engine is used to correct what type of force?
 - a. Primary vibration
 - b. Secondary vibration
 - c. Rocking couple
 - d. Rolling couple
5. A gram weighs about the same as a _____.
 - a. Paper clip
 - b. Chicken feather
 - c. Penny
 - d. Dime
6. Reciprocating weight is also called _____.
 - a. Balance weight
 - b. Bob weight
 - c. Rotating weight
 - d. Inertia weight
7. Connecting rods should be weighed and balanced _____.
 - a. Before reconditioning
 - b. After reconditioning

8. Pistons and connecting rods can be ground from what area when removing weight?
 - a. Balancing pad
 - b. Weight bore
 - c. Sides
 - d. Thrust surface(s)
9. Which of the following is not reciprocating weight?
 - a. Piston
 - b. Big end of a connecting rod
 - c. Small end of a connecting rod
 - d. Piston ring
10. How is the crankshaft usually balanced?
 - a. Material is welded onto the counterweight.
 - b. Pistons are replaced until a matched set is achieved.
 - c. Material is drilled out of the counterweight.
 - d. Heavy metal is used to increase the weight of the counterweight.