

Cellular Mobile Radio Systems: Designing Systems for Capacity Optimization  
Husni Hammuda

Copyright © 1997 by John Wiley & Sons Ltd  
Print ISBN 0-471-95641-4 Electronic ISBN 0-470-84254-9

# **Cellular Mobile Radio Systems**

# **Cellular Mobile Radio Systems**

***Designing Systems for Capacity Optimization***

**Husni Hammuda**

*Ericsson Ltd*

*Guildford, Surrey*

**JOHN WILEY & SONS**

**Chichester · New York · Weinheim · Brisbane · Toronto · Singapore**

Copyright © 1997 by John Wiley & Sons Ltd  
Baffins Lane, Chichester,  
West Sussex PO19 1UD, England

National 01243 779777  
International (+44) 1243 779777

e-mail (for orders and customer service enquiries): cs-books @ wiley.co.uk

Visit our Home Page on <http://www.wiley.co.uk> or <http://www.wiley.com>

Reprinted June 1998

All Rights Reserved. No part of this publication may be reproduced, stored in a retrieval system, or transmitted, in any form or by any means, electronic, mechanical, photocopying, recording, scanning or otherwise, except under the terms of the Copyright, Designs and Patents Act, 1988 or under the terms of a licence issued by the Copyright Licensing Agency, 90 Tottenham Court Road, London, W1P 9HE, UK, without the permission in writing of the Publisher, with the exception of any material supplied specifically for the purpose of being entered and executed on a computer system, for exclusive use by the purchaser of the publication.

Neither the authors nor John Wiley & Sons Ltd accept any responsibility or liability for loss or damage occasioned by any person or property through using the material, instructions, methods or ideas contained herein, or acting or refraining from acting as a result of such use. The authors and Publisher expressly disclaim all implied warranties, including merchantability of fitness for any particular purpose. There will be no duty on the authors or Publisher to correct any errors or defects in the software.

Designations used by companies to distinguish their products are often claimed as trademarks. In all instances where John Wiley & Sons is aware of a claim, the product names appear in initial capital or capital letters. Readers, however, should contact the appropriate companies for more complete information regarding trademarks and registration.

#### *Other Wiley Editorial Offices*

John Wiley & Sons, Inc., 605 Third Avenue,  
New York, NY 10158-0012, USA

VCH Verlagsgesellschaft mbH,  
Pappelallee 3, D-69469 Weinheim, Germany

Jacaranda Wiley Ltd, 33 Park Road, Milton,  
Queensland 4064, Australia

John Wiley & Sons (Canada) Ltd, 22 Worcester Road,  
Rexdale, Ontario M9W 1L1, Canada

John Wiley & Son (Asia) Pte Ltd, 2 Clementi Loop #02-01,  
Jin Xing Distripark, Singapore 0512

#### *Library of Congress Cataloging-in-Publication Data*

Hammuda, H.

Cellular mobile radio systems: designing systems for capacity optimization / H. Hammuda.

p. cm.

Includes bibliographical references and index.

ISBN 0-471-95641-4

1. Cellular radio. I. Title.

TK6570.M6H26 1997

621.3845'6—dc21

97-9343

CIP

#### *British Library Cataloguing in Publication Data*

A catalogue record for this book is available from the British Library

ISBN 0 471 95641 4

Typeset in 10½/12½pt Palatino by Pure Tech India Ltd, Pondicherry

Printed and bound in Great Britain by Biddles Ltd, Guildford and King's Lynn

This book is printed on acid-free paper responsibly manufactured from sustainable forestation, for which at least two trees are planted for each one used for paper production.

**To  
My Parents,  
Wife, and  
Daughters**

# Contents

<b>1</b>	<b>Introduction</b>	<b>1</b>
<b>2</b>	<b>Measures of Spectral Efficiency in Cellular Land Mobile Systems</b>	<b>7</b>
2.1	Introduction	7
2.2	Importance of Spectral Efficiency Measures	8
2.3	Possible Measures of Spectral Efficiency	9
2.3.1	Mobiles/Channel	9
2.3.2	Users/Cell	11
2.3.3	Channels/MHz	11
2.3.4	Erlangs/MHz	12
2.4	Best Measures of Spectral Efficiency in Cellular Systems	12
2.4.1	Practical Considerations of the Measure Erlangs/MHz/km <sup>2</sup>	13
2.4.2	Alternative Spectral Efficiency Measures	14
2.5	A Possible Spectral Efficiency Measure for Digital Systems	16
2.6	Measures of Spectral Efficiency and the Quality of Cellular Systems	17
<b>3</b>	<b>Spectral Efficiency of Analogue Modulation Techniques</b>	<b>21</b>
3.1	Introduction	21
3.2	Basic Analogue Modulation Techniques	22
3.2.1	Analogue Baseband Signal Transmission	25
3.2.2	Double-Sideband (DSB) Modulation	28
3.2.3	Amplitude Modulation (AM)	33
3.2.4	Single-Sideband (SSB) Modulation	35
3.2.5	Angle (Non-linear) Modulation	37
3.2.6	General Comparison of Various Analogue Modulation Techniques	39
3.3	Mathematical Interpretation of Channels/MHz/km <sup>2</sup>	40
3.4	Calculation of the Number of Cells per Cluster $N_c$	42
3.4.1	Cellular Geometry	43
3.4.2	Cell Shapes	43
3.4.3	Principles of Hexagonal Geometry	43
3.5	Relationship Between Co-channel Re-use Ratio and Protection Ratio in a Cellular System	46
3.5.1	Definition of Protection Ratio	46
3.6	Co-channel Interference Models	47
3.6.1	General Features of the Geographical Models	49
3.6.2	General Features of the Statistical Models	50
3.6.3	Model I: Geographical Model with One Interferer	51

3.6.4	Model II: Geographical Model with Six Interferers	55
3.6.5	Model III: Geographical Model with Several Tiers of Interferers	58
3.6.6	Model IV: Fading Only Statistical Model	62
3.6.7	Model V: Shadowing Only Statistical Model	65
3.6.8	Model VI: Fading and Shadowing Statistical Model	66
3.7	Comparison of the Various Models	68
3.7.1	Mathematical Justification of the Geographical Models	72
3.8	Spectral Efficiency of Modulation Techniques Based on the Six Interferers Geographical Model	74
3.8.1	Factors Governing the Cell Area $A$	75
<b>4</b>	<b>Spectral Efficiency of Digital Modulation Techniques</b>	<b>79</b>
4.1	Introduction	79
4.2	Basic Digital Modulation Techniques	80
4.2.1	Digital Amplitude Modulation (AM) Techniques	82
4.2.2	Digital Frequency Modulation (FM) Techniques	83
4.2.3	Digital Phase Modulation (PM) Techniques	84
4.2.4	$M$ -ary Digital Modulation Schemes	84
4.2.5	Hybrid Digital Modulation Schemes	85
4.2.6	Performance Comparison of Various Digital Modulation Techniques	85
4.3	Voice Coding (Speech Digitisation)	89
4.3.1	Basic Types of Voice Coders	91
4.3.2	General Comparison of Various Voice Coders	92
4.3.3	A Voice Coder for Cellular Systems	93
4.4	Spectral Efficiency of Digital Modulation Techniques Within Cellular Systems	94
4.4.1	Practical or Subjective Approach	95
4.4.2	Theoretical or Objective Approach	95
4.4.3	Comparison of the Subjective and Objective Approaches	97
<b>5</b>	<b>Spectral Efficiency of Multiple Access Techniques</b>	<b>101</b>
5.1	Introduction	101
5.2	Basic Multiple Access Techniques	102
5.2.1	Frequency Division Multiple Access (FDMA)	103
5.2.2	Time Division Multiple Access (TDMA)	104
5.2.3	Code Division Multiple Access (CDMA)	106
5.3	Theoretical Efficiency of Multiple Access Techniques	109
5.3.1	Multiplexing with Orthogonal Signals	109
5.3.2	Multiplexing with Non-orthogonal Signals	111
5.3.3	Synchronous and Asynchronous Multiplexing	112
5.3.4	TDMA Versus FDMA Using the Sampling Theorem	113
5.4	Practical Efficiency of Multiple Access Techniques	113
5.5	Multiple Access Efficiency Factor	114
5.5.1	Multiple Access Efficiency Factor for FDMA	115
5.5.2	Multiple Access Efficiency Factor for WB-TDMA	116
5.5.3	Multiple Access Efficiency Factor for NB-TDMA	118
5.5.4	Multiple Access Efficiency Factor for CDMA	118
5.5.5	Typical Values for $\eta_T$	119

<b>6 Overall Spectral Efficiency of Cellular Systems – Evaluation and Results</b>	<b>123</b>
6.1 Introduction	123
6.2 Overall Spectral Efficiency of Cellular Systems	123
6.2.1 Calculation of the Channel Spacing for Various Cellular Systems	124
6.3 Effect of Bandwidth Expansion on Spectral Efficiency	125
6.3.1 Six-Interferer Cellular Model	126
6.3.2 Spread Spectrum	127
6.3.3 Wideband Frequency Modulation	128
6.3.4 The Shannon Limit	129
6.3.5 Double-Sideband, Amplitude and Single-Sideband Modulation	130
6.3.6 Comparison of Bandwidth Expansion Methods	130
6.4 Power–Bandwidth Exchange in Digital Systems and Spectral Efficiency	132
6.4.1 Digital AM Techniques	132
6.4.2 Digital FM Techniques	132
6.4.3 Digital PM Techniques	132
6.4.4 Hybrid AM/PM Digital Techniques	133
6.5 Alternative Spectral Efficiency Measure: Erlangs/MHz/km <sup>2</sup>	133
6.6 Evaluation of some Existing and Proposed Cellular Systems	136
6.6.1 Modulation Efficiency of Analogue and Digital Techniques	136
6.6.2 Spectral Efficiency of Cellular Systems	137
<b>7 Methods of Obtaining a value for the Protection Ratio</b>	<b>153</b>
7.1 Introduction	153
7.2 Definition and Mathematical Representation of the Protection Ratio	153
7.3 Methods of Evaluation	155
7.3.1 Mathematical Derivation	155
7.3.2 Objective Measurements	156
7.3.3 Subjective Tests	158
7.3.4 Field Trials	160
7.4 Comparison and Recommendations	161
7.4.1 Recommendations and Suggestions for the Subjective Assessment of the Protection Ratio	162
<b>8 Concluding Remarks</b>	<b>165</b>
<b>9 Recommendations and Suggestions for Future Work</b>	<b>173</b>
<b>APPENDIX A: An Alternative Co-channel Interference Model</b>	<b>175</b>
<b>APPENDIX B: Erlang B Table-Block Calls Cleared Model</b>	<b>177</b>
<b>APPENDIX C: Abbreviations</b>	<b>187</b>
<b>APPENDIX D: List of Symbols</b>	<b>191</b>
<b>Index</b>	<b>195</b>

# Preface

The idea of the book was born during the time when the second generation cellular system was looming on the horizon. At that time, the world was divided into three distinct camps as far as looking for a standard: Europe, North America and Japan. It was obvious at the outset that Europe was in favour of a Pan-European Second Generation Cellular System with one standard across Europe, benefiting from the successful Nordic experience. North America with different systems as a continuation of the deregulation of the telecommunications industry; And Japan with a standard which may or may not agree with the North American second generation cellular system. One thing was far from obvious: what would the new cellular system look like?

Every conceivable proposal for the second generation cellular system was offered: analogue as well as digital systems, a variety of modulation techniques including hybrids, FDMA, TDMA and CDMA multiple access techniques etc. The solutions offered were as diversified as the performance claims made by their advocates were highly controversial. In particular, the spectral efficiency figures given for various proposals were highly debatable. A global standard definition or measure for the spectral efficiency of cellular systems was lacking. Furthermore, different people used different parameters and methods to assess the spectral efficiency!

The main purpose of this book is to create an awareness for the issues, techniques and technologies which may affect the spectral efficiency of cellular mobile radio systems. This is particularly important with the rapid expansion of mobile services coupled with the importance of optimising the spectrum. It is true that more frequency bands above 1 GHz are becoming available for the mobile services. But it is also true that the demand will always exceed



expectations and that multimedia applications, hungry for spectrum, will soon be extremely popular amongst the majority of users. The spectral efficiency of radio systems will and should always be the prime concern of the telecommunications industry: investors, engineers, researchers, managers, operators, marketing executives ..... the list is just too long.

The book presents a rigorous and comprehensive approach to the definition and evaluation of the spectral efficiency of cellular land mobile radio systems. A cellular system is seen as a combination of a modulation and multiple access technique and the method is equally applicable to both analogue and digital systems. The work includes a tabulated comparison of a number of first and second generation cellular systems including many of the proposals for the second generation system to enhance the comparisons.

Some readers may argue that analogue systems are too old fashioned to have been considered at all in the book; they may be right. There are two reasons why I thought analogue systems should be considered for their spectral efficiency. Firstly, it is academically desirable to consider all systems, digital as well as analogue, to acquire a full knowledge of the subject. That can show the technical development of systems over the years and also use the analogue technology as a bench mark in order to appreciate the advantages of digital systems. Secondly, analogue cellular systems will be around for years to come but with limited radio spectrum and hence there is a particular need to optimise these systems for spectral efficiency.

The book should be of benefit to the practising engineers as well as research students in the field of cellular radio. In particular, they should find the general methodology and modelling of interest. The book will also be useful for managers and marketing executives interested in the technical aspects of cellular mobile radio systems. The tabulated results may prove invaluable for all.

Finally, I am sure that there are many issues which could have been included in my book and that there are ideas which some of the readers would wish me to share with them. It may be impossible to include all the issues but as an alternative, I will always be more than happy to receive comments and have discussions around the subject of my book.

*Guildford, Surrey*  
*October 1997*

**Husni Hammuda**

# Index

- ACPM (amplitude companded PM) 157
- ACSSB (amplitude companded SSB)
  - 138, 157, 159
- ACSSB/FDMA 140, 170
- adaptive DM (ADM) 91, 94
- adaptive DPCM (ADPCM) 91, 94
- additive white Gaussian noise (AWGN) 24, 28, 87, 112
- adjacent channel interference 48
- alternative spectral efficiency measures 14
- amplitude and phase shift keying (APK) 85
  - 4-APK 86, 89, 96, 133, 138, 170
  - 4-ASK 84
  - 8-APK 86, 89, 96, 133, 138
  - 8-PSK 84, 86, 89, 96, 132, 138
  - 16-APK 85, 86, 96, 133, 138
  - 16-PSK 84, 86, 96, 132, 138
  - 16-QAM 84, 86, 96, 132, 138
- amplitude detection 84
- amplitude distortion 25
- amplitude modulation (AM) 24, 33, 80,
  - 103, 130, 136, 157, 159, 161
  - digital techniques 82, 132, 170
- amplitude protection ratio 63, 64
- amplitude shift keying (ASK) 82, 86, 89,
  - 96, 132, 138
- AMPS 72, 119, 140
- analogue modulation techniques 22
- analogue to digital (A/D)
  - conversion 90
- angle modulation 37
- angle modulation techniques 24, 39
- APC 173
- APK 133, 170
- asynchronous multiplexing 112
- asynchronous TDMA 168
- automatic frequency control (AFC)
  - 49, 160, 173
- automatic gain control (AGC) 49, 160,
  - 173
- average signal energy per bit to noise power spectral density ( $E_b/N_0$ ) 87
- bandpass AWGN 31
- bandwidth of
  - AM signals 33
  - DSB signals 30
  - FM signals 38
  - SSB signals 36
- baseband digital message signal 81
- baseband signal transmission 25
- BER versus  $E_b/N_0$  89
- BER versus SNR 87
- best measures of spectral efficiency 12
- binary phase shift keying (BPSK) 84, 86,
  - 96, 132, 138
- bit error bursts 89
- bit error rate (BER) 80, 86, 89, 92, 156
- bit synchronization 81
- blocked calls cleared (BCC) 134
- blocked calls delayed (BCD) 134
- blocking probability 18, 134, 135
- blocking system model 134
- busy hour 70, 135
- C450 140
- Carson's rule 38
- categories of co-channel interference models 48
- CCIR five point scale 158, 161, 162
- CCIR 9, 86, 163
- CCITT 9, 163
- CD 900 119, 143
- cell shapes 43
- cell splitting 2
- cellular concept 1
- cellular geometry 43
- channel coding 90, 114
- channel spacing 95
- channels/MHz (efficiency measure) 11
- channels/MHz/km<sup>2</sup> 165
- chip rate 106

- chirp or pulse FM 107
- cluster area 42
- cluster 40
- co-channel cell separation D 43
- co-channel cells 45
- co-channel interference 44, 47, 114, 126, 154
- co-channel re-use ratio D/R 45
- co-channel re-use ratio vs protection ratio 46
- co-channel re-use ratio 43
- code division multiple access (CDMA) 103, 106–108, 110, 118–19, 125, 168, 173
- coding 90, 160, 173
- coherence bandwidth 105
- coherent detection 81, 83, 84, 89
  - of CP-FSK 84
- coherent PSK 84
- common signalling channels 114
- communication quality 93
- companding 26, 49, 157
- comparison of bandwidth expansion methods 130
- constant envelope digital modulation techniques 89
- constellation diagrams 84
- continuous phase FSK (CP-FSK) 84
- co-user interference 106, 108, 112
- CP-FSK 96, 138
- cross-correlation 106, 112, 118
  
- DE-BPSK 86, 96, 138
- definition (of) multiple access efficiency factor 114
- definition of protection ratio 46, 47, 153
- delay spread 88, 89
- delta modulation (DM) 91
- demand assignment 102, 103
- demodulation of DSB signals 29
- department of trade and industry (DTI) 9, 163
- differential PCM (DPCM) 91
- differential PSK (DPSK) 84, 86, 96, 138
- differentially encoded PSK (DE-PSK) 84
- digital communication system 81, 90
- digital frequency modulation (FM) 83
- digital modulation 87, 136
- digital modulation speed 95
- digital modulation techniques 80, 86, 132
- digital phase modulation (PM) 84
- digital transmission 79
  
- direct sequence (DS) 106, 111
- distortion-free transmission 109, 111–12
- distortionless transmission 25
- diversity reception 89, 139
- diversity signal reception 49
- DMS 90 143
- doppler shifts 114
- double-sideband (DSB) modulation 28, 130
- double-sideband suppressed carrier (DSB-SC) 29, 83
- DQPSK 86, 96, 138
- DS/CDMA 112
- DS/SSMA 111
- duplex filters 105
  
- effect of bandwidth expansion on spectral efficiency 125
- effect of bandwidth expansion on the signal to noise ratio 129
- encryption 79, 108
- energy per bit  $E_b$  97
- envelope detection (non-coherent modulation) 35, 83
  - of SSB signals 36
- equalization 89, 105, 160
- equalizers 26
- equivalent channel spacing 95
- erlang 133
- erlang-B distribution 134
- erlang-C distribution 134
- erlangs/MHz (efficiency measure) 12
- erlangs/MHz/km<sup>2</sup> 13, 133, 165
- error correction coding 89
- error detection and correction coding 139
- error protection and correction coding 92, 93–4
  
- fading & shadowing statistical mode 51
- fading and shadowing statistical model 66
- fading only statistical model 51, 62, 70
- fading simulators 157, 158
- fading 88
- fast frequency hopping (FFH) 107
- features of the geographical models 49
- features of the statistical models 50
- Federal Communications Commission (FCC) 9, 163
- FH/CDMA 110, 112
- field measurements 48

- field trials (to assess protection ratio) 160
- figure of merit 156, 157
- first generation cellular systems 137
- first tier co-channel cells 55
- FM 103, 136, 161, 169
- FM/FDMA 119, 183, 170
- free space loss 50
- frequency deviation constant 37
- frequency diversity 105
- frequency division multiple access (FDMA) 103, 104, 109, 111–12, 119, 168
- frequency domain coders 91
- frequency duplexing 109
- frequency hopping (FH) 107
  - and direct sequence (FH–DS) 107
  - pattern 110
  - SSMA 109
- frequency modulation (FM) 37, 80
- frequency shift keying (FSK) 83, 89, 96, 107, 132, 138
- frequency synthesizers 108
- frequency-selective fading 157
- frequency stability 49
- fundamentals of hexagonal geometry 43
- geographical model 69
  - with many tiers of interferers 50
  - with one interferer 50, 51, 69, 73
  - with several tiers of interferers 58
  - with six interferers 50, 55, 69, 73, 74
- geometrical co-channel interference
  - model with six interferers 124
- GMSK 170
- grade of service 18, 134–5
- group special mobile (GSM) 139
- GSM 8, 143
- guard time 106, 114
- hand-off rate 42, 76
- holding time 134
- hybrid AM/PM digital techniques 133
- hybrid digital modulation 85
- hybrid digital techniques 81
- hybrid voice coders 93
- hybrid waveform coders 92
- instantaneous amplitude 80
- instantaneous frequency deviation 37
- instantaneous phase deviation 37, 80
- interference density  $N_o$  97
- intermediate frequency (IF) filter 48
- intermodulation distortion 26
- intermodulation products 48
- intersymbol interference 83, 89
- inverse fourth-power dependence 48
- ISDN 79
- kbps/MHz/km<sup>2</sup> 16, 165
- log PCM 94
- log-normal distribution (shadowing) 51
- lowpass AWGN 31
- M-ary ASK 84
- M-Ary digital modulation 84, 97, 132
- M-ary FSK 84
- mathematical derivation (of protection ratio) 155
- mathematical justification of the
  - geographical models 72
- mathematical representation of the
  - protection ratio 153
- MATS-D/N 143
- MATS-D/W 143
- MAX II 143
- mean opinion score (MOS) 93, 159
- measures of spectral efficiency in cellular systems 7
- minimum shift keying (MSK) 84
- mobiles/channel (efficiency measure) 9
- modulation efficiency 41, 45, 125
- modulation index 83
- MOS 161
- MSK 86, 89, 96, 132, 138, 170
- multipath characteristics 89
- multipath fading 105, 114
- multiple access efficiency 102, 114, 116, 125
- multiple access efficiency factor
  - for CDMA 118
  - for FDMA 115
  - for NB-TDMA 118
  - for WB-TDMA 116
- multiple access interference 112, 119
- multiple access techniques 101, 102
- multiplexing 101
- NAMT 140
- narrowband AWGN 31
- narrowband FM (NBFM) 38
- narrowband TDMA (NB-TDMA) 105
- narrowband TDMA 105, 118, 119, 169

- NBFM 157
- near-to-far effect 106, 108
- NMT-450 140
- NMT-900 140
- non-coherent detection 81
  - of FSK 83
- non-linear distortion 26
- non-orthogonal CDMA 119
- non-orthogonal multiplexing 111
- non-orthogonal signals 111
- normal (Gaussian) distribution 65
- normalized SNR 88
- NTIA (National Telecommunication and Information Agency) 157
- Nyquist rate 113
  
- objective protection ratio
  - measurements 156
- objective protection ratio 97, 132
- objective quality measure 92, 98
- on-off keying (OOK) 82
- orthogonal frequency channels 110
- orthogonal codes 108, 119
- orthogonal multiple access techniques 168
- orthogonal multiplexing techniques 111
- orthogonal signals 109
- orthogonality 112
- overall spectral efficiency of cellular system 123
  
- pan-european digital cellular system 94
- peak frequency deviation 38
- phase coherence 82
- phase deviation constant 37
- phase modulation (PM) 37, 80–1, 159, 170
- phase or delay distortion 26
- $\pi/4$  shift QPSK 150
- power control 106
- power efficiency of the AM signal 35
- power spectral density (psd) 27
- practical efficiency of multiple access techniques 113
- preamble 106
- pre-assignment 102, 103
- pre-emphasis/de-emphasis 49
- principles of hexagonal geometry 43
- probability density function (PDF) 63
- probability of completion of messages 76
- probability of hand-off 76
- propagation constant 74
- propagation loss over a flat earth 50
- propagation over a plane earth 72
- protection ratio 51, 153
  - for 25/30 kHz FM 72
- pseudo-noise (PN) 106, 111
- pseudorandom binary pattern 106
- pseudorandom phase inversions 106
- pseudorandom user code 106
- PSK 89
- pulse code modulation (PCM) 91
- pure loss model 134
  
- QPSK 84, 86, 89, 96, 132, 138, 170
- QPSK/NB-TDMA 150
- quadrature amplitude modulation (QAM) 83, 86, 89, 96, 132, 138, 170
- quadrature partial response (QPR) 83, 86, 96, 138
- quantizing 90
- queuing system model 134
- quieting techniques 70
  
- radio regulatory division (RRD) 9, 163
- random access 102
- Rayleigh distribution 50, 62, 67
- Rayleigh fading 89
- recommendations for the subjective assessment of the protection ratio 162
- relative spectral efficiency 124
  
- S900-D 143
- sampling 90
- sampling theorem 113
- SBC 94
- second-generation cellular systems 137
- set-up channels 114
- SFH 900 143
- SFH/CDMA 109
- shadowing only statistical model 51, 65, 70
- Shannon Limit 129
- Shannon model 126, 129
- Shannon–Hartley 130
- Shannon’s capacity 168
- Shannon’s law 111, 112
- Shannon’s theorem 129
- signal to noise performance of
  - AM systems 34
  - baseband systems 27
  - DSB-SC systems 31
  - FM systems 39

- SSB systems 36
- signal to noise ratio (SNR) 86
- SINAD 156, 157, 158
- single-sideband (SSB) 72, 83, 103, 130, 136, 157, 159, 161, 169
  - modulation 35
- six-interferer cellular model 126
- six-interferer geographical model 167
- slow frequency hopping (SFH) 107
- slow frequency hopping CDMA 118
- SNR 92
- source coders 91
- source coding 114
- speaker recognizability 158
- spectral efficiency measures 8
  - and quality 17
  - for digital system 16
- spectral efficiency
  - of analogue modulation 21
  - of cellular systems 137
  - of digital modulation 94
  - of modulation techniques 74
  - of possible measures 9
- speech naturalness 98
- speech quality 46
- speed of a modulation technique 86
- speed of the digital modulation 97, 118
- spread spectrum multiple access (SSMA) 106
- spread spectrum systems 127, 173
- SSMA 111
- standard deviation 51, 66–7
- statistical model category 70
- sub-band coders 91
- subjective quality 92
- subjective tests (of protection ratio) 158
- supervision channels 114
- Suzuki distribution 67
- symbol duration 83
- synchronisation 105–6, 108
  - synchronization preamble 114
- synchronous multiplexing 112
- synchronous TDMA 111, 168
- synthetic voice quality 91, 93
  
- TACS 72, 119, 140
- talker recognition 91
- talker recognizability 98
- theoretical efficiency of multiple access techniques 109
- three-level duobinary signals 83
- threshold effect of FM systems 39
- time and frequency hopping (TFH) 107
- time channels 125
- time delay spread 114
- time division multiple access (TDMA) 103, 104, 109, 110, 125, 168
- time domain coders 91
- time hopping (TH) 107
- time hopping and direct sequence (TH-DS) 107
- time-frequency domain 106
- time–frequency signal space 109
- time–frequency signals 110
- toll quality 93
- transmission bandwidth 35
- transmission bit rate 92–3
- transmission quality 46
- transmitted bits per second per Hertz (bps/Hz) 86
- transmitted signal power of
  - AM signals 33
  - DSB signals 30
  - FM signals 38
  - SSB signals 36
- trunking 101
  
- urbanization degree 50
- users/cell (efficiency measure) 11
- users/MHz/km<sup>2</sup> 15, 135, 165
  
- VLSI 79
- vocoders 91, 92, 93
- voice activated transmission 70
- voice channels/MHz/km<sup>2</sup> 14
- voice coders 91, 168
- voice coding (speech digitization) 89
- voice processing delay time 98
- voice quality 46
  
- waiting time 18, 134
- waveform coders 91
- waveform techniques 91
- wideband FM (WBFM) 38, 128, 131, 136, 169
- wideband TDMA (WB-TDMA) 104, 105, 116
- world administrative radio conference (WARC) 47, 153

# 1

## **Introduction**

The potential of communicating with moving vehicles without the use of wire was soon recognized following the invention of radio equipment by the end of the nineteenth century and its development in the beginning of the twentieth century [1.1, 1.2]. However, it is only the availability of compact and relatively cheap radio equipment which has led to the rapid expansion in the use of land mobile radio systems. Land mobile radio systems are now becoming so popular, for both business and domestic use, that the available frequency bands are becoming saturated without meeting even a fraction of the increasing demand. To give an example, the estimated number of mobile radios in use in 1984 was about 540 000 with a growth rate of about 10% per annum in the UK; estimates of growth rates up to 20% have been made for other European countries [1.3]. Using these figures leads to estimates of approximately 2.5 million UK users by the end of this century. A growth rate of 20% annually would lead to more than 13 million users worldwide by the year 2 000. Such a figure is comparable to the 11 million business and 18 million residential fixed telephone in use at present [1.3].

Solutions to spectral congestion in the land mobile radio environment can be envisaged in the following ways.

### **(a) The Cellular Concept**

In cellular systems, spectral efficiency is achieved by employing spatial frequency re-use techniques on an interference-limited basis. Frequency re-use refers to the use of radio channels on the same carrier frequency to cover different areas which are separated from one another by a sufficient distance so that co-channel interference is not objectionable [1.4]. This is achieved by dividing the service area into smaller 'cells', ideally with no gaps or overlaps, each cell being

served by its own base station and a set of channel frequencies. The power transmitted by each station is controlled in such a way that the local mobile stations in the cell are served while co-channel interference, in the cells using the same set of radio channel frequencies, is kept acceptably minimal. An added characteristic feature of a cellular system is its ability to adjust to the increasing traffic demands through cell splitting. By further dividing a single cell into smaller cells, a set of channel frequencies is re-used more often, leading to a higher spectral efficiency. Examples of analogue cellular land mobile radio systems are AMPS (Advanced Mobile Phone System) in the USA, TACS (Total Access Cellular System) in the UK and NAMTS (Nippon Advanced Mobile Telephone System) in Japan – the latter was the first to become commercially available in the Tokyo area in 1979.

Cellular systems can offer several hundred thousand users a better service than that available for hundreds by conventional systems. It is fair to conclude, therefore, that the adoption of a cellular system is inevitable for any land mobile radio service to survive ever increasing public demands, particularly considering the severe spectrum congestion which is already occurring within many of the allocated frequency bands. It is not surprising then, that almost the only common feature amongst the various proposals for second-generation cellular systems for the USA, Europe and Japan, is the use of the cellular concept. It is generally agreed that a cellular system would greatly improve the spectral efficiency of the mobile radio service.

### **(b) Moving to Higher Frequency Bands**

The demand for mobile radio service has been such that severe spectrum congestion is occurring within many of the allocated frequency bands. First generation analogue cellular mobile radio occur below 1 GHz. Second generation digital cellular mobile radio also occur below 1 GHz. Personal Communication Networks (PCN) are rapidly moving into the next GHz band (1.7–1.9 GHz) and a Universal Mobile Telecommunications System (UMTS) – envisaged for the end of the 1990s, will be using part of the 1.7–2.3 GHz band [1.5]. It is obvious that there are plenty of spectra above 1 GHz which makes it a natural move to go for higher frequency bands than those currently in use. Frequencies up to the millimetric band (about 60 GHz) are being investigated. In these regions, large amounts of spectrum are available to accommodate wideband modulation systems and the radio wave attenuation is significantly greater than the free-space loss which helps to define a very high capacity cellular system [1.6, 1.7]. Nevertheless, it is necessary to conduct detailed propagation measurements



in these frequency bands as well as to define system parameters adequately. Indeed, it is necessary to solve all the problems which can arise at these frequencies before implementation is economically viable and technologically possible.

**(c) Maximizing the Degree to which the Present Mobile Bands are Utilized**

Despite the proven success of first-generation cellular systems, which are predominantly FM/FDMA based, it is strongly believed that more spectrally efficient modulation and multiple access techniques are needed to meet the increased demand for the service. This has prompted considerable research into more spectrally efficient techniques and modes of information transmission. As a consequence, a wide variety of modulation and multiple access techniques are offered as a solution. Amongst the modulation techniques suggested are wideband and narrowband digital techniques (TDMA and FDMA based), spread spectrum and ACSSB, alongwith conventional FM analogue systems. Voice channel spacings vary from 5 kHz for ACSSB systems up to 300 kHz or more for spread spectrum systems. Furthermore, each multiple access technique – FDMA, TDMA, CDMA and a hybrid technique – is claimed, by various proponents, to have the highest spectral efficiency when applied to cellular systems.

From (a), (b) and (c) above, it can be clearly seen that both employing the cellular concept and maximizing the spectrum usage of the present frequency bands are necessary to help alleviate spectral congestion in the land mobile radio environment and to fulfil the increased demands for service. In fact, higher spectral efficiency leads to more subscribers, cheaper equipment due to mass production, low call charges and, overall, lower cost per subscriber.

It is also obvious that a rigorous and comprehensive approach to the definition and evaluation of spectral efficiency of cellular mobile radio systems is necessary in order to settle the conflicting claims of existing and proposed cellular systems, especially if the British government is to go ahead with its plan to involve the private sector in the management of the radio spectrum [1.8].

To date many methods have been employed in an attempt to evaluate and compare different modulation and multiple access techniques in terms of their spectral efficiency. These methods include pure speculation, mathematical derivations, statistical estimations as well as methods based upon laboratory measurements. Unfortunately, none of the above methods can be said to be rigorous or

conclusive. Mathematical methods, for instance, have been used to predict the co-channel protection ratio, yet this is a highly subjective system parameter. Other approaches, such as the statistical methods, are difficult for the practising engineer to apply in general. Results based on computer simulations must be treated with a degree of suspicion when the basis of such simulations is not revealed. Not only have improper ways of comparison appeared in the literature, such as comparing the spectral efficiency of SSB and FM to that of TDMA, but there is also a lack of a universal measure for spectral efficiency within cellular systems. In fact, a comparison between spectral efficiency values is only meaningful if it refers to:

- the same service;
- the same minimum quality;
- the same traffic conditions;
- the same assumptions on radio propagation conditions;
- the same agreed universal spectral measure.

Thus, it is essential to establish a rigorous and comprehensive set of criteria with which to evaluate and compare different combinations of modulation and multiple access techniques in terms of their spectral efficiency in the cellular land mobile radio environment. This book discusses such a method which must necessarily embrace the following features.

- (a) A measure of spectral efficiency which accounts for all pertinent system variables within a cellular land mobile radio network. For such a measure to be successful it must reflect the quality of service offered by different cellular systems.
- (b) Modulation systems, as well as multiple access techniques, must be assessed for spectral efficiency computation including both analogue and digital formats.
- (c) It is necessary to model the cellular mobile radio system to account for propagation effects on the radio signal. On the other hand, it is also necessary to model the relative geographical locations of the transmitters and receivers in the system so as to be able to predict the effect of all significant co-channel interfering signals on the desired one.

- (d) To include the quality of the cellular systems in terms of the grade of service, two traffic models are considered. The first one is a 'pure loss' or blocking system model, in which the grade of service is simply given by the probability that the call is accepted. The other is a queuing model system in which the grade of service is expressed in terms of the probability of delay being greater than  $t$  seconds.
- (e) The method combines a global approach which accounts for all system parameters influencing the spectral efficiency in cellular land mobile radio systems and the ease of a practical applicability to all existing and proposed, digital and analogue, cellular land mobile radio systems. Hence such systems can be set in a ranked order of spectral efficiency.

This study also demonstrates the crucial importance of the protection ratio in the evaluation of the spectral efficiency of modulation systems. It is also argued that since the protection ratio of a given modulation system inherently represents the voice quality under varying conditions, it is imperative that such a parameter is evaluated subjectively. Furthermore, the evaluation of the protection ratio should be performed under various simulated conditions, e.g. fading and shadowing, in such a way that the effect of these conditions is accounted for in the overall value of the protection ratio. In addition, any technique which improves voice quality or overcomes hazardous channel conditions in the system should also be included in the test. Consequently, the effects of amplitude companding, emphasis/de-emphasis, coding, etc. will influence the overall value of the protection ratio. A number of current and proposed cellular mobile radio systems are evaluated using the comprehensive spectral efficiency package developed.

## REFERENCES

- [1.1] Jakes, W. C., 1974 '*Microwave Mobile Communications*' John Wiley and Sons, New York
- [1.2] Young, W. R., 1979 'Advanced Mobile Phone Services: Introduction, Background and Objectives', *Bell Syst. Tech. J.*, **58** (1) January pp. 1-14
- [1.3] Matthews, P. A., 1984 'Communications on the Move' *Electron. Power* July pp. 513-8

- [1.4] MacDonald, V. H., 1979 'Advanced Mobile Phone Services: The Cellular Concept' *Bell Syst. Tech. J.*, **58** (1) January pp. 15–41
- [1.5] Horrocks, R. J. and Scarr, R. W. A., 1994 *Future Trends in Telecommunications* John Wiley and Sons, Chichester
- [1.6] McGeehan, J. P. and Yates, K. W., 1986 'High-Capacity 60 GHz Micro-cellular Mobile Radio Systems' *Telecommunications* September pp. 58–64
- [1.7] Steele, R., 1985 'Towards a High-Capacity Digital Cellular Mobile Radio System' *IEE Proc.*, **158** Pt F pp. 405–15
- [1.8] Purton, P., 1988 'The American Applaud Trail-Blazing British' *The Times Monday*, 12 December 1988, p. 28

# 2

## ***Measures of Spectral Efficiency in Cellular Land Mobile Radio Systems***

### **2.1 INTRODUCTION**

In order to assess the efficiency of spectral usage in cellular land mobile radio networks, it is imperative to agree upon a measure of spectral efficiency which accounts for all pertinent system variables within such networks. An accurate and comprehensive definition of spectral efficiency is indeed the first step towards the resolution of the contemporary conflicting claims regarding the relative spectral efficiencies of existing and proposed cellular land mobile radio systems. An accurate spectral efficiency measure will also permit the estimation of the ultimate capacity of various existing and proposed cellular systems as well as setting minimum standards for spectral efficiency. In undertaking the task, the problems currently experienced whereby some cellular systems claim to have a superior spectral efficiency, either do not show their measure of spectral efficiency or use a spectral efficiency measure which is not universally acceptable could be avoided.

The purpose of this chapter is to survey various possible measures of spectral efficiency for cellular land mobile radio systems, discussing their advantages, disadvantages and limitations. Our criterion is to look for a suitable measure of spectral efficiency which is universal to all cellular land mobile radio systems and can immediately give a comprehensive measure of how efficient the system is, regardless of the modulation and multiple access techniques employed. Such a measure should also be independent of the technology implemented,

with an allowance for the introduction of any technique which may improve the spectral efficiency and/or system quality. Furthermore, no changes or adaptations in the spectral efficiency measure should be necessary to accommodate any cellular system which may be proposed in the future. With the above considerations, the most suitable spectral efficiency measure will be adopted to establish a rigorous and comprehensive set of criteria with which to evaluate and compare cellular systems which employ different combinations of modulation and multiple access techniques in terms of their spectral efficiency. This will be the subject of the following chapters.

## 2.2 IMPORTANCE OF SPECTRAL EFFICIENCY MEASURES

Measures of spectral efficiency are necessary in order to resolve the contemporary conflicting claims of spectral efficiency in cellular land mobile radio systems. In such systems, an objective spectral efficiency measure is needed for the following reasons.

(a) It allows a bench mark comparison of all existing and proposed cellular land mobile radio systems in term of their spectral efficiency. For the GSM (Groupe Spécial Mobile) Pan-European cellular system, for example, there are conflicting claims regarding the relative spectral efficiencies of proposed digital systems [2.1]. On the other hand, there are at least seven different analogue cellular land mobile radio systems in operation throughout the world, including five in Europe [2.2], which also have conflicting spectral efficiency claims. The resolution of such claims is complicated even further by the present lack of a precise definition of spectral efficiency within cellular systems which all parties can agree upon.

(b) An objective measure of spectral efficiency will help to estimate the ultimate capacity of different cellular land mobile radio systems. Hence, recommendations towards more spectrally efficient modulation and multiple access techniques can be put forward. Recommendations of this nature will certainly influence research and development to move in parallel with more spectrally efficient techniques and technologies and perhaps reaching higher spectral efficiency by approaching their limits. Estimates of the ultimate capacity of various cellular systems would also help to forecast the point of spectral saturation, when coupled with demand growth projections.

(c) An accurate measure of spectral efficiency is also useful in setting minimum spectral efficiency standards, especially in urban areas and city centres where frequency congestion is most likely to occur. Such standards will prevent manufacturers lowering system costs or offering higher quality services at the expense of squandering the spectrum. This is particularly necessary with services that are provided by competitive companies, which is very much the case nowadays. Setting these standards will also lead to either more research and development into systems which do not comply with the minimum spectral efficiency standards or, perhaps more sensibly, to concentration of more research on systems which initially comply with the efficiency standards so as to achieve an even higher spectral efficiency. The task of setting minimum efficiency standards would be carried out by independent consultative committees such as the International Radio Consultative Committee (CCIR) and the International Telegraph and Telephone Consultative Committee (CCITT), and enforced by regulatory authorities, such as the Radio Regulatory Division (RRD) of the Department of Trade and Industry (DTI) in the UK and the Federal Communications Commission (FCC) in the USA.

## **2.3 POSSIBLE MEASURES OF SPECTRAL EFFICIENCY**

The planned spatial re-use of frequency, characteristic to cellular systems, requires a spectral efficiency measure at the system level. In this context, spectral efficiency for a cellular system is the way the system uses its total resources to offer a particular public service to its highest capacity.

Hatfield [2.3] surveyed various proposed measures of spectral efficiency for land mobile radio systems, reviewing the advantages, disadvantages and limitations of each. In this section possible measures of spectral efficiency will be examined, paying particular attention to their relevance and adequacy to cellular systems, both present and future.

### **2.3.1 Mobiles/Channel**

In the measure 'Mobiles/Channel', the number of mobile units per voice channel is used to indicate the spectral efficiency. The measure 'Users/Channel' has also been used with the same meaning. This is

probably the simplest way of measuring the spectral efficiency of a mobile radio system. Nevertheless, this measure has certain shortcomings.

(a) In this spectral efficiency measure, traffic considerations are not taken into account. Take, for example, the case of two systems being compared, where the mobiles in the two systems do not generate the same amount of traffic. If the users in one system generate twice as much busy hour traffic as the other system, for instance, and both systems could carry the same total traffic, then that system can appear to be twice as efficient in terms of mobiles per channel. It is obvious that using the above spectral efficiency measure, one system can purposely try to inflate its efficiency by adding more mobiles that generate little or no traffic to the system.

(b) Channel spacing is not taken into consideration. A wide variety of cellular land mobile radio systems can be offered as a solution to spectral congestion. Channel spacings used could vary from 5 kHz for cellular systems employing SSB modulation techniques, up to 300 kHz or more for spread spectrum systems. Unfortunately, the spectral efficiency measure in terms of Mobiles/Channel does not account for channel spacing, and hence any advantages or disadvantages of using one channel spacing over another are simply not shown in the measure. This problem can be solved by using mobiles per unit bandwidth as a measure of spectral efficiency. In fact, both Mobiles/MHz and Users/MHz have been used by some authors [2.4, 2.5].

(c) The above measure of spectral efficiency does not take into account the geographic area covered by the system. To exemplify this, consider two land mobile radio systems, whereby one of them uses a base station with a very high antenna which covers a large area of a 50 km radius and the other system uses a base station with a low antenna covering only a small area of a 10 km radius. The two systems may be serving the same number of mobiles (or users), however, in the latter case, more base stations can be spaced at closer distances so as to re-use the same radio frequencies, and hence serve more mobiles within the same frequency band allocated for the service. In cellular land mobile radio systems, the geographic area covered by the system is a particularly important parameter which needs to be part of the spectral efficiency measure.



### 2.3.2 Users/Cell

The measure of spectral efficiency as the number of users (or mobiles) in a cell was introduced to account for cellular coverage, characteristic to cellular land mobile radio systems. Although used by some authors [2.5], the users/Cell measure also has certain deficiencies:

(a) The problem of unequal traffic still exists. This problem can be solved by considering the amount of traffic which a particular system can provide per cell.

(b) The problem of unequal channel spacings used by different systems remains unsolved. Even by using the Channels/Cell measure, the number of channels the system can provide per cell raises the objection of systems operating in different sizes of frequency bands. Indeed, this can be adjusted by assuming all systems that are being compared use the same amount of spectrum. Nevertheless, the measure as Channels/Cell does not instantly reflect that.

(c) Adopting Users/Cell seems to overcome the problem of unequal coverage – one of the objections of using Users/Channel as a spectral efficiency measure. Unfortunately, it can still be argued that different systems may use different cell sizes and different numbers of cells to offer the same service within one region. This is because cellular systems employing different modulation techniques, with possibly different channel spacings, may have different immunities against co-channel interference. Consequently, some systems can employ smaller cells than others to offer the same quality of service. It is obvious then, that a more accurate measure of the geographic area covered by the system needs to be used. The most sensible measure of the service area is to use square kilometres or square miles to replace the concept of ‘cell’ in the above spectral efficiency measure.

### 2.3.3 Channels/MHz

The measure of spectral efficiency as the number of channels which a mobile radio system can provide per MHz appears in the literature [2.6]. It gets around some of the deficiencies in the previous measures. It particularly solves the problem of unequal channel spacings employed by different systems by specifying the number of channels which a system can provide per given MHz of the frequency band

allocated for the service. The problem of unequal traffic is a minor one here since the amount of traffic on the channel can be used instead. Nonetheless, the problem of unequal coverage remains unsolved. Although the spectral efficiency measure Channel/MHz is suitable for point-to-point radio communications or one cell mobile radio systems, it is not adequate for cellular land mobile radio systems.

### 2.3.4 Erlangs/MHz

In this measure of spectral efficiency, the Erlang\* is used as a measure of traffic intensity. The Erlang (E) measures the quantity of traffic on a voice channel or a group of channels per unit time and, as a ratio of time, it is dimensionless. One Erlang of traffic would occupy one channel full time and 0.05 E would occupy it 5% of the time. Thus, the number of Erlangs carried cannot exceed the number of channels [2.7]. Using the above measure of spectral efficiency obviates some of the shortcomings in the previous measures. It certainly solves the problem of unequal traffic by using the Erlang as a definite measure of traffic on a given number of voice channels provided by the system. It implicitly accounts for the different channel spacings provided by different systems by measuring the amount of traffic in Erlangs per MHz of the frequency band allocated for the service. In other words, the spectral efficiency in Erlangs/MHz is directly related to the measure in Channels/MHz, provided that blocking probabilities or waiting times are equal when systems are being compared. The measure in Erlangs/MHz seems to be a good one, however, its principal disadvantage is that the geographic area is still not included.

In the following section, the 'spacial efficiency' factor will be added to the above measure, in an attempt to arrive at the best measure (or measures) of spectral efficiency in cellular systems.

## 2.4 BEST MEASURES OF SPECTRAL EFFICIENCY IN CELLULAR SYSTEMS

Some proposed measures of spectral efficiency for cellular land mobile radio systems were discussed in the previous section. Although none of the suggested measures can be said to be totally

\* The unit of telephone traffic is the Erlang, named after the Danish telephone engineer A. K. Erlang, whose paper on traffic theory, published in 1909, is now considered a standard text.

appropriate for cellular systems, it can be deduced that a successful spectral efficiency measure must have the following features:

- (a) It must measure the traffic intensity on the radio channels available for the cellular service. The Erlang as a suitable and definite measure of traffic intensity will be used for this purpose.
- (b) The amount of traffic intensity should be measured per unit bandwidth of the frequency band allocated for the service (in MHz). This will inherently account for different channel spacings employed by various systems.
- (c) The spacial efficiency factor or the geographic re-use of frequency must also be included in the measure in terms of unit area of the geographic zone covered by the service (in  $\text{km}^2$  or  $\text{miles}^2$ ).

The measure of spectral efficiency as Erlangs/MHz seems to satisfy both (a) and (b) above. To include the spatial frequency re-use factor, it is necessary to know the amount of traffic per unit bandwidth per unit area covered by the service. This leads to the spectral efficiency measure of

$$\text{Erlangs/MHz/km}^2.$$

By Using the above measure of spectral efficiency to compare different cellular systems, the system which can carry more traffic in terms of Erlangs per MHz of bandwidth in a given unit area of service can be said to be spectrally more efficient.

#### **2.4.1 Practical Considerations of the Measure Erlangs/MHz/km<sup>2</sup>**

The measure of spectral efficiency in terms of Erlangs/MHz/km<sup>2</sup> proves to be adequate, comprehensive and appropriate for cellular land mobile radio systems. In the following, the choice of units for this measure is justified and the practical considerations and assumptions are pointed out.

- (a) In the above measure of spectral efficiency, MHz is used as the bandwidth unit, not kHz or Hz. This is because the measure deals mainly with voice transmission (telephony), with possible channel spacings of 5 kHz for SSB cellular systems and up to 300 kHz or more for spread spectrum. In this case, a MHz can give rise to several voice channels, and since the number of Erlangs cannot exceed the

number of channels, a reasonable number of Erlangs per MHz can be obtained. However, if kHz or Hz is used in the measure instead of MHz, a very small fraction of an Erlang per kHz or per Hz is obtained, which is not favourable for practical systems comparisons.

(b) It is also practicable to use  $\text{km}^2$  (or  $\text{miles}^2$ ) as a measure of unit area since it can accommodate a reasonable number of mobiles (or users), which will in turn give rise to a reasonable spectral efficiency figure for practical systems.

(c) In the above measure of spectral efficiency, there is an inherent assumption that the traffic is uniformly distributed across the entire service area, which is usually not the case in realistic systems. However, this does not seem to be a serious defect in the measure for two reasons. Firstly, the relative spectral efficiency of cellular systems under identical conditions is of prime interest, and hence any assumptions made will be equally applicable to all systems under comparison. Secondly, average traffic figures can be adequately used, assuming uniform traffic within individual cells and not the entire service area. Conversely, relative and absolute spectral efficiencies are mostly needed in areas where the greatest demands in terms of capacity exist. In these areas, such as city centres and metropolitan areas, the smallest possible cell sizes must be used to give rise to a maximum capacity, and hence the traffic can be considered to be uniformly distributed within each individual cell.

(d) The above spectral efficiency measure can be used in such a way that the efficiency of the multiple access technique employed by the cellular system is accounted for. This is achieved by considering the traffic on the voice channels during communication only, hence excluding guard bands, supervision and set-up channels, etc. This can be represented by the use of 'paid Erlangs' in the above measure, which reflects the amount of traffic intensity in the channels dedicated to voice transmission during communication.

### 2.4.2 Alternative Spectral Efficiency Measures

An alternative and conceptually simpler measure of spectral efficiency in cellular land mobile radio systems is presented in terms of:

Voice Channels/MHz/ $\text{km}^2$ .

In this measure, the more voice channels per MHz a cellular system can provide in a unit area, the more spectrally efficient it is considered to be. 'Voice Channels' is used in the measure to exclude guard bands, supervision and set up channels, etc. Hence, the measure accounts for the efficiency of the multiple access technique employed by the cellular system. This measure is particularly useful for cellular systems which employ analogue modulation techniques, for which the channel spacing is directly known. Nevertheless, the spectral efficiency measure in Channels/MHz/km<sup>2</sup> is also applicable to digital systems if the number of voice channels in the frequency band allocated for the service is known. This is usually specified in terms of the number of channels per carrier, where the carrier spacing is given. This is equally applicable to digital systems which use time division multiple access (TDMA) techniques.

The spectral efficiency measure in Channels/MHz/km<sup>2</sup> is directly related to the previous measure in Erlangs/MHz/km<sup>2</sup>. The conversion from Channels/MHz/km<sup>2</sup> to E/MHz/km<sup>2</sup> is readily obtained given an equivalent blocking probability or waiting time on the voice channels, when the service is required (Figure 2.1), depending on the traffic model used.

Another alternative measure of spectral efficiency for cellular systems is:

Users/MHz/km<sup>2</sup>.

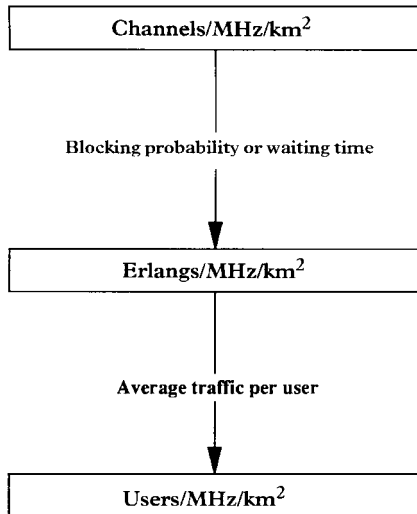

Figure 2.1 Best Measures of Spectral Efficiency in Cellular Systems

It measures the efficiency of a cellular system in terms of the number of users per MHz of bandwidth allocated for the service in a unit area.

Unlike the way the term 'user' in the above measure is commonly used, it is intended to be used in such a way that traffic considerations are included in the measure. To achieve this, the 'user' is defined in terms of the average traffic which he or she generates in a given cellular system. Consequently, the spectral efficiency measure in terms of Users/MHz/km<sup>2</sup> is directly related to the measure in terms of E/MHz/km<sup>2</sup> (Figure 2.1). To give an example, if the spectral efficiency of a cellular system is 5 E/MHz/km<sup>2</sup> and the average traffic generated per user in the system is say 0.05 E, then the efficiency of that cellular system is 100 Users/MHz/km<sup>2</sup>.

## 2.5 A POSSIBLE SPECTRAL EFFICIENCY MEASURE FOR DIGITAL SYSTEMS

Digital cellular land mobile radio systems are becoming increasingly popular. In fact, various digital cellular systems are being proposed and some deployed in Europe [2.1, 2.8], North America [2.9] and Japan [2.10]. In a digital modulation system, the voice channel is defined in terms of kbits/s (kbps). The bandwidth efficiency of a digital modulation system can be described in terms of bps/Hz. This latter parameter can be extended to arrive at the following new spectral efficiency measure for digital cellular systems:

$$\text{kbps/MHz/km}^2.$$

According to this new spectral efficiency measure, the more kbps per MHz a digital system can provide in a unit service area, the more spectrally efficient it is considered to be. In the following, the advantages, disadvantages and limitations of the above spectral efficiency measure are discussed in comparison with the best spectral efficiency measures in the previous section:

(a) The spectral efficiency measure in terms of kbps/MHz/km<sup>2</sup> is attractive to use with digital cellular systems, although it is not particularly useful for analogue systems. On the other hand, the measure in terms of Channels/MHz/km<sup>2</sup> is equally applicable to both analogue and digital cellular systems, since a voice channel has a definite meaning whether it is analogue or digitized. Also, the measure in

terms of  $E/\text{MHz}/\text{km}^2$  is superior to that in terms of  $\text{kbps}/\text{MHz}/\text{km}^2$  because the former is equally applicable to both analogue and digital cellular systems. Furthermore, the amount of traffic (in Erlangs) which can be carried by a group of analogue voice channels is no different from the traffic which can be carried by the same number of digitized voice channels.

(b) The measure in terms of  $\text{kbps}/\text{MHz}/\text{km}^2$  does not account for the channel spacing or the digitized channel bit rate. This is due to the fact that the measure  $\text{kbps}/\text{MHz}/\text{km}^2$  was constructed using the spectral efficiency of a digital system in  $\text{bps}/\text{Hz}$  without considering the bit rate of the digitized channel in  $\text{kbps}$ . In this case, the spectral efficiencies of the same digital system employing two different digitized voice channels bit rates will falsely appear to be identical. To give an example, if a cellular system employs a digital modulation technique with a spectral efficiency of say  $2 \text{ bps}/\text{Hz}$  and uses a channel bit rate of  $16 \text{ kbps}$  and another cellular system employs the same digital modulation technique but uses a different channel bit rate of say  $32 \text{ kbps}$ , then the spectral efficiencies of the two cellular systems in terms of  $\text{kbps}/\text{MHz}/\text{km}^2$  will be identical. Nevertheless, considering the channel bit rate in  $\text{kbps}$ , it is obvious that the former digital cellular system can be twice as spectrally efficient as the latter. In fact, the spectral efficiency of a digital cellular system in terms of  $\text{kbps}/\text{MHz}/\text{km}^2$  can be presented in terms of  $\text{Channels}/\text{MHz}/\text{km}^2$  if coupled with the bit rate of the digitized voice channel in  $\text{kbps}$ .

For the above reasons, measures in terms of  $\text{Channels}/\text{MHz}/\text{km}^2$ ,  $E/\text{MHz}/\text{km}^2$  and  $\text{Users}/\text{MHz}/\text{km}^2$  are superior and more comprehensive than the measure in  $\text{kbps}/\text{MHz}/\text{km}^2$ . Indeed, the measure  $\text{kbps}/\text{MHz}/\text{km}^2$  is useful to use with data-based cellular services such as telex and facsimile.

## 2.6 MEASURES OF SPECTRAL EFFICIENCY AND THE QUALITY OF CELLULAR SYSTEMS

From the previous analysis, the best measures of spectral efficiency for cellular land mobile radio systems are:

- $\text{Channels}/\text{MHz}/\text{km}^2$
- $\text{Erlangs}/\text{MHz}/\text{km}^2$
- $\text{Users}/\text{MHz}/\text{km}^2$

The above spectral efficiency measures prove to be adequate, comprehensive and appropriate for cellular systems. For these spectral efficiency measures to be completely successful, the quality of service offered by different cellular systems has to be included. However, when we talk about quality in terms of cellular land mobile radio systems, typically, the following three kinds of quality requirements are considered [2.11]:

- (a) The degree of coverage in terms of traffic or area. That is to say, the percentage of the total area in which the service is available.
- (b) The grade of service in terms of blocking probability or waiting time, when the service is required.
- (c) The interference levels within the cellular system. This is judged by the protection ratio of a given modulation technique employed by the cellular system, which gives rise to a particular voice quality.

Of the above three quality requirements, only (b) and (c) are relevant to our spectral efficiency measures. Quality in terms of the grade of service directly applies to the spectral efficiency measures in Erlangs/MHz/km<sup>2</sup> and Users/MHz/km<sup>2</sup> since these include traffic considerations which are functions of the blocking probability or waiting time, when the service is required. On the other hand, the voice quality requirement is applicable to the measure in Channels/MHz/km<sup>2</sup>, since the number of channels obtainable per MHz is limited by the voice quality offered to the users of the system (i.e. the number of channels per MHz should not be increased at the expense of voice quality). However, since the above spectral efficiency measures are interrelated (Figure 2.1), it can be deduced that the quality in terms of both the grade of service and voice quality apply to all of our candidate spectral efficiency measures. In general, the grade of service and voice quality can be fixed to a given standard which all mobile radio systems in comparison have to comply with, and hence, a uniform quality is maintained throughout the comparison.

## REFERENCES

- [2.1] Maloberti, A., 1987 'Definition of the Radio Subsystem for the GSM Pan-European Digital Mobile Communications System', Proc. *International Conference on Digital Land Mobile Radio Communications Venice*, 30 June – 3 July 1987 pp. 37–47



- [2.2] Callender, M., 1987 'Future Public Land Mobile Telecommunication Systems – A North American Perspective' *Proc International Conference on Digital Land Mobile Radio Communications, Venice, 30 June – 3 July 1987* pp. 73–83
- [2.3] Hatfield, D. N., 1977 'Measures of Spectral Efficiency in Land Mobile Radio' *IEEE Trans. Electromag. Compat.* **EMC-19** August pp. 266–8
- [2.4] Lane, R. N., 1973 'Spectral and Economic Efficiencies of Land Mobile Radio Systems' *IEEE Trans. Veh. Technol.* **VT-22**, (4) November pp. 93–103
- [2.5] Cooper, G. R., 1983 'Cellular Mobile Technology: The Great Multiplier', *IEEE Spectrum*, June pp. 30–7
- [2.6] Matthews, P. A. and Rashidzadeh, B., 1986 'A Comparative Study of Wideband TDMA and TD/FDMA Systems for Digital Cellular Mobile Radio', *Second Nordic Seminar on Digital Land Mobile Radio Communications, 14–16 October 1986* pp. 291–5
- [2.7] Bear, D., 1980 'Principles of Telecommunications – Traffic Engineering' *IEE Telecommunications Series 2*
- [2.8] Eckert, K. D., 1987 'Conception and Performance of the Cellular Digital Mobile Radio Communication System CD 900' *37th IEEE Vehicular Technology Conference, Tampa, Florida, 1–3 June 1987* pp. 369–77
- [2.9] Tarallo, J. A. and Zysman, G. I., 1987 'A Digital Narrow-Band Cellular System' *37th IEEE Vehicular Technology Conference Tampa, Florida, 1–3 June 1987* pp. 279–80
- [2.10] Akaiwa, Y. and Nagata, Y., 1987 'Highly Efficient Digital Mobile Communications with a Linear Modulation Method' *IEEE J. Sel. Areas Commun.* **SAC-5**, (5) June pp. 890–5
- [2.11] Gamst, A., 1987 'Remarks on Radio Network Planning' *37th IEEE Vehicular Technology Conference, Tampa, Florida, 1–3 June 1987* pp. 160–5

# 3

## ***Spectral Efficiency of Analogue Modulation Techniques***

### **3.1 INTRODUCTION**

In the previous chapter, various measures of spectral efficiency in cellular land mobile radio systems were discussed and possible measures of spectral efficiency measures were presented. The most appropriate measures of spectral efficiency for cellular systems are:

- Channels/MHz/km<sup>2</sup>
- Erlangs/MHz/km<sup>2</sup>
- Users/MHz/km<sup>2</sup>

These spectral efficiency measures prove to be adequate, comprehensive and appropriate for cellular systems. Also, they include the quality of service offered by different cellular systems in terms of both voice quality and grade of service. Nevertheless, these spectral efficiency measures need to be mathematically interpreted to be able to calculate the spectral efficiency of various cellular systems. In cellular land mobile radio systems, there are two major parameters which govern the spectral efficiency: the modulation technique employed and the multiple access technique used to trunk the signals in the system. For the sake of convenience as well as flexibility, we propose to calculate the efficiency of the modulation technique and the efficiency of multiple access of a given cellular system in isolation. The overall spectral efficiency of a particular land mobile radio system is

then obtained by combining the two types of efficiency due to the modulation technique employed and the multiple access technique used in conjunction.

The main purpose of this chapter is to devise a criterion by which the spectral efficiency of various analogue modulation techniques can be evaluated, when employed in cellular systems. To aid this objective, it is necessary to have an overview of the basic analogue modulation techniques, with particular emphasis on the prime parameters which determine the efficiency of a modulation technique. The spectral efficiency measure in terms of Channels/MHz/km<sup>2</sup> is then mathematically interpreted and the efficiency of a cellular system employing a particular modulation technique is presented as a function of channel spacing, number of cells per cluster and cell area.

The concept of cellular geometry is also introduced in order to relate the number of cells per cluster to the co-channel re-use ratio, and hence the spectral efficiency due to a modulation technique is given in terms of the channel spacing, co-channel re-use ratio and the cell area. It is of great importance, however, to relate the spectral efficiency of modulation techniques to speech quality experienced by the users in the cellular system. The speech quality, in turn, is influenced by the signal to co-channel protection ratio determined by the modulation technique used. To establish a relationship between the protection ratio and the co-channel re-use ratio, it is necessary to model the cellular land mobile radio environment in such a way that propagation effects on the radio signal are accounted for. It is also necessary to model the relative geographical locations of the transmitters and the receivers in the system so as to be able to predict all the significant co-channel interference affecting the desired signal. For this purpose, a thorough comparative study of six different models is conducted and the best model of all is used. The modulation efficiency is given in terms of channel spacing, protection ratio, propagation constant and cell area.

## 3.2 BASIC ANALOGUE MODULATION TECHNIQUES

All information-bearing signals must ultimately be transmitted over some intervening medium (channel) separating the transmitter and the receiver. In the case of land mobile radio communications, this medium is free space. Modulation is the process whereby signals which naturally occur in a given frequency band, known as the

baseband, are translated into another frequency band so that they can be matched to the characteristics of the transmission medium [3.1]. Thus, for example, electrical signals created by a human voice need to be translated into the radio frequency (RF) spectrum before they can be translated for radio communication purposes. They then have to be transmitted back into the baseband, by a complementary process known as demodulation before they can be used to reproduce the signals which are audible to the recipient. Also, modulation is the process of transferring information to a carrier, and the reverse operation of extracting the information-bearing signal from the modulated carrier is called demodulation [3.2].

The information to be transmitted is contained in the baseband signal; however, it is not feasible to transmit it in this form and modulation is required for the following reasons

- (a) To match the signal to the frequency characteristics of the transmission medium, as mentioned before.
- (b) For the ease of radiation. If the communication channel consists of free space, such as in land mobile radio, then antennas are necessary to radiate and receive the signal. For efficient electromagnetic radiation, antennas need to have physical dimensions of the same order of magnitude as the wavelength of the radiated signal. Voice signals, for example, have frequency components down to 300 Hz. Hence, antennas some 100 km long would be necessary if the signal is radiated directly. If modulation is used to impress the voice signal on a high-frequency carrier, say 900 MHz, then antennas need be no longer than ten centimetres or so.
- (c) To overcome equipment complexity. Modulation can be used for translating the signal to a location in the frequency domain where design requirements of signal processing devices (e.g. filters and amplifiers) are easily met.
- (d) To reduce noise and interference. It is possible to minimize the effect of noise in communication systems by using certain types of modulation techniques. These techniques generally trade bandwidth for noise reduction and thus require a transmission bandwidth much larger than the bandwidth of the baseband signal.
- (e) For multiplexing. Land mobile radio systems are mainly used for voice transmission (telephony). A band-limited voice signal has components between 300 Hz and 3 kHz, thus, modulation

is used to translate different baseband signals to different spectral locations to enable different receivers to select the desired voice channel.

(f) For frequency assignment. In land mobile radio systems, the use of modulation allows several hundreds of users to transmit and receive simultaneously at different carrier frequencies, using the same radio frequency band. This kind of need for modulation and the previous case (e) are grouped under the multiple access techniques, and hence their efficiencies will not be considered in this chapter.

In analogue modulation, a parameter of a continuous high-frequency carrier is varied in proportion to a low-frequency baseband message signal. The carrier to be modulated is usually sinusoidal and has the following general mathematical form:

$$x_c(t) = v(t) \cos [w_c t + \phi(t)] \quad w_c = 2\pi f_c \quad (3.1)$$

where  $v(t)$  is the instantaneous amplitude of the carrier,  $f_c$  is the carrier frequency and  $\phi(t)$  is the instantaneous phase deviation of the carrier.

The carrier can be modulated by varying one of the above parameters in accordance with the amplitude of the baseband message signal.

In principle, all analogue modulation techniques fall into two major categories: linear or amplitude modulation techniques and non-linear or angle modulation techniques. If  $v(t)$  is linearly related to the message signal  $m(t)$ , then we have linear or amplitude modulation. If  $\phi(t)$  or its time derivative is linearly related to  $m(t)$ , then we have angle modulation, which is a non-linear modulation. The following is an overview of basic analogue modulation techniques, paying particular attention to three important parameters. These parameters are: the transmission bandwidth, the transmitted power and the average signal to noise power ratio performance of each modulation technique. Whenever possible, the message signal  $m(t)$  will be taken as a band-limited voice signal, normalized such that  $-1 \leq m(t) \leq 1$  and having frequency components between 300 Hz and 3 kHz. The noise at the input to the receiver is considered to be additive white Gaussian noise (AWGN). Furthermore, for the signal to noise ratio comparisons, all modulation systems will be assumed to operate with the same average transmitted power.

### 3.2.1 Analogue Baseband Signal Transmission

Baseband systems are communication systems in which signal transmission takes place without modulation. They are useful as a basis for the comparison of various analogue modulation techniques. Figure 3.1(a) shows a typical block diagram of a baseband communication system, where signal power amplification and necessary filtering are performed by the transmitter and the receiver. No modulation or demodulation is performed and the message signal is modified at the output by the non-ideal characteristics of the channel and the addition of noise in the system. If the baseband system is to be distortionless, then the message signal at the output should satisfy the following equation:

$$m_o(t) = km_i(t - t_d) \tag{3.2}$$

where  $m_i(t)$  is the input message signal,  $m_o(t)$  is the output message signal,  $k$  is constant representing the attenuation caused by the channel and  $t_d$  is a constant representing the time delay caused by the channel.

From Equation (3.2), it is clear that for distortionless transmission, the message is simply attenuated and delayed in time, and hence the content of the message is unaltered. Nevertheless, some distortion will always occur in signal transmission, and three common types of distortion can be identified as follows:

(a) Amplitude distortion which occurs when the amplitude response of the channel over the range of frequencies for the input

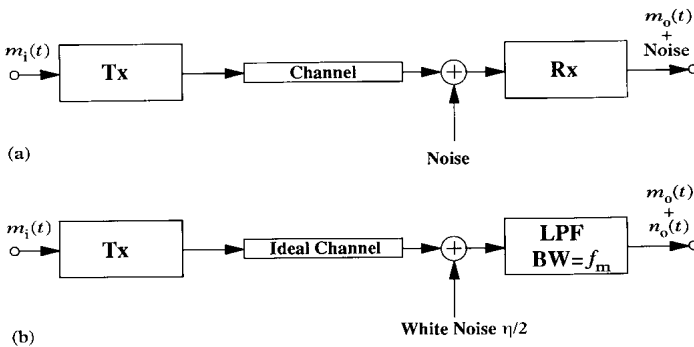

**Figure 3.1** Baseband Communication System. Tx, Transmitter; Rx, Receiver. (a) Distortionless System. (b) Baseband System and White Noise

signal is not flat. In this case, different spectral components of the input message are attenuated differently. The attenuation shown in Equation (3.2) will not be constant but will be a function of frequency  $k(f)$ . The most common forms of amplitude distortion are excess attenuation of high or low frequencies in the signal spectrum and it is worse for wideband signals.

(b) Phase or delay distortion which occurs when different frequency components of the input message signal suffer different amounts of time delay. In this case, the time delay in Equation (3.2) is not constant but a function of frequency  $t_d(f)$ . For voice transmission, delay distortion is not a problem since the human ear is insensitive to this type of distortion.

(c) Non-linear distortion due to the presence of non-linear elements in the channel such as amplifiers. Non-linear elements have transfer characteristics which act linearly when the input signal is small, but distort the signal when the input amplitude is large. Mathematically, the non-linear device can be modelled by:

$$m_o(t) = k_1 m_i(t) + k_2 m_i^2(t) + k_3 m_i^3(t) + \dots \quad (3.3)$$

where  $k_1, k_2, k_3, \dots$ , are constants. To demonstrate the effect of non-linear distortion, consider the input to be the sum of two cosine signals with frequencies  $f_1$  and  $f_2$ . In this case, the output will contain harmonic distortion terms at frequencies  $2f_1, 2f_2$  and intermodulation distortion terms at frequencies  $f_1 \pm f_2, 2f_1 \pm f_2, 2f_2 \pm f_1$ , etc. This problem is of great concern in systems where a number of different message signals are multiplexed together and transmitted over the same channel.

The types of distortion mentioned in (a) and (b) above are called linear distortion and can be cured by the use of equalizers which are essentially designed to compensate for the different attenuation and delay levels of the signal at different frequency components. The non-linear distortion mentioned in (c) can be reduced using companders which compress the signal prior to transmission for its amplitude to fall within the linear range of the channel. Then, the signal at the receiver is expanded to restore its appropriate level. Companding is widely used in telephone systems to reduce non-linear distortion and also to compensate for signal levels which differ between soft and loud talkers.

### Signal to noise performance of baseband systems

The signal quality at the output of an analogue modulation system is usually measured in terms of the average signal power to noise power, defined as:

$$(S/N)_o = \frac{E\{m_o^2(t)\}}{E\{n_o^2(t)\}} \quad (3.4)$$

where  $m_o(t)$  is the output signal message,  $n_o(t)$  is the noise at the output of the system and  $E\{x\}$  denotes the average of  $x$ .

The message signal will be taken as a voice signal, band-limited to  $f_m$  and hence satisfies the condition:

$$M_o(f) = 0 \quad \text{for } f \geq f_m \text{ and } f \leq -f_m \quad (3.5)$$

where  $M_o(f)$  is the Fourier transform of  $m_o(t)$ .

Since our objective is the comparison of various analogue modulation techniques in terms of their signal to noise ratio (SNR) performance, it suffices to consider the special case of an ideal channel with additive white noise with a power spectral density (psd) of  $\eta/2$  W/Hz (see Figure 3.1(b)). Also, assuming ideal filters, in the case of a baseband system, a lowpass filter with cut-off frequency  $f_m$  is needed at the receiver. Now, if  $E\{m_o^2(t)\}$  is the recovered average signal power  $P_R$  at the output, then:

$$(S/N)_o = \frac{P_R}{\eta f_m} = \gamma(\text{say}) \quad (3.6)$$

Hence:

$$(S/N)_o = \frac{\text{received signal power}}{\text{in-band noise power}}. \quad (3.7)$$

If the channel is not ideal but distortionless, then using Equation (3.2), the signal to noise power ratio can be presented in terms of transmitted signal power  $P_T$  at the input to the system:

$$(S/N)_o = k^2 \frac{P_T}{\eta f_m}. \quad (3.8)$$

In general, the signal to noise power ratio given in Equation (3.8) is considered to be an upper limit for practical analogue baseband performance. The signal to noise ratios shown in Equations (3.6) and



(3.8) will be taken as a basis to compare the performance of various modulation techniques.

**3.2.2 Double-Sideband (DSB) Modulation**

This is probably the simplest form of linear or amplitude modulation. It is achieved by multiplying the message signal  $m(t)$  by a high-frequency carrier  $x_c(t)$  as shown in Figure 3.2(a), where:

$$x_c(t) = \cos (\omega_c t). \tag{3.9}$$

For simplicity, the phase of the carrier is dropped and the amplitude is made equal to unity, since this will not affect the generality of the analysis. The modulated message signal is hence given by:

$$x(t) = m(t) \cos (\omega_c t) \tag{3.10}$$

$\uparrow \downarrow$

$$X(f) = \frac{1}{2} \frac{A_y}{B} [M(f + f_c) + M(f - f_c)] \tag{3.11}$$

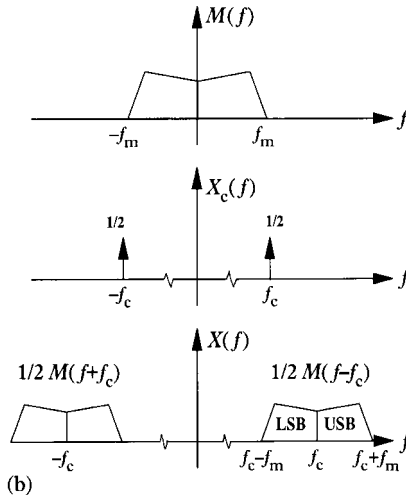
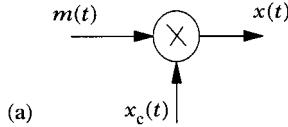

**Figure 3.2** (a) DSB Modulator. (b) DSB Modulation in the Frequency Domain

where  $X(f)$  and  $M(f)$  are the Fourier transforms of  $x(t)$  and  $m(t)$  respectively.

The result is graphically represented in Figure 3.2(b) in the frequency domain. Using this type of modulation simply translates the spectrum of the baseband message signal to the carrier frequency. This is called double-sideband suppressed carrier (DSB-SC) modulation, since there is no carrier term in the modulated signal.

*Demodulation of DSB signals*

To demodulate a DSB signal, it is multiplied by a carrier replica and then the resultant is passed through a lowpass filter as shown in Figure 3.3(a). The spectrum of the demodulated signal before and after filtering is shown in Figure 3.3(b). Assuming an ideal channel,  $Y(f)$  is given by:

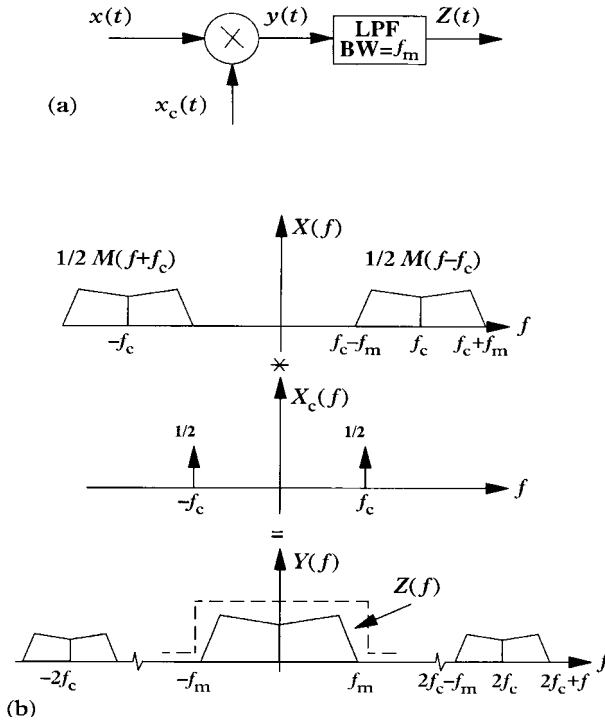

**Figure 3.3** (a) DSB Demodulator. (b) DSB Demodulation in the Frequency Domain

$$Y(f) = \frac{1}{2}M(f) + \frac{1}{4}[M(f + 2f_c) + M(f - 2f_c)]. \quad (3.12)$$

After lowpass filtering:

$$Z(f) = \frac{1}{2}M(f) \quad (3.13)$$

$$\therefore z(t) = \frac{1}{2}m(t). \quad (3.14)$$

The message signal  $m(t)$  is hence fully recovered provided that:

$$f_c > f_m.$$

The demodulation scheme used above is called synchronous or coherent demodulation. It requires a local oscillator at the receiver which is precisely synchronous with the carrier signal used to demodulate the message signal. This is a very stringent condition which cannot be satisfied easily in practice. There are other demodulation techniques that are used to generate a coherent carrier and these are described in [3.2] and [3.3].

#### *Transmitted signal power and bandwidth of DSB signals*

From Figure 3.2(b), it can be seen that the bandwidth  $B_T$  required to transmit a message signal of bandwidth  $f_m$  using DSB-SC is:

$$B_T = 2f_m. \quad (3.15)$$

It is obvious that this is a waste of spectrum since both sidebands of the signal are transmitted, yet they carry identical information.

The average transmitted power  $P_T$  of the DSB modulated signal  $x(t)$  is given by:

$$P_T = E\{x^2(t)\} \quad (\text{Assuming } 1\Omega \text{ load}) \quad (3.16)$$

$$P_T = E\{m^2(t) \cos^2(w_c t)\} \quad (3.17)$$

$$\therefore P_T = \frac{1}{2}P_m \quad (3.18)$$

where  $P_m$  is the average message signal power.

Signal to noise performance of DSB-SC systems

To find the signal to noise performance of a DSB-SC modulation system, consider the model depicted in Figure 3.4, with ideal channel and ideal subsystems. The signal is assumed to be corrupted with additive white Gaussian noise (AWGN)  $n(t)$ , with the following quadrature representation [3.4]:

$$n(t) = n_c(t) \cos(\omega_c t) - n_s(t) \sin(\omega_c t) \tag{3.19}$$

where  $n(t)$  is the Narrowband or bandpass AWGN,  $n_c(t)$  is the in-phase, lowpass AWGN component and  $n_s(t)$  is the quadrature, lowpass AWGN component.

The psds of  $n(t)$ ,  $n_c(t)$  and  $n_s(t)$  are shown in Figure 3.5.

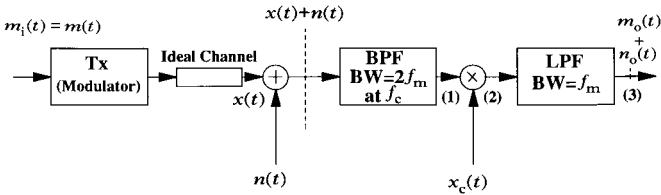

Figure 3.4 Model of DSB Modulation System Corrupted with AWGN

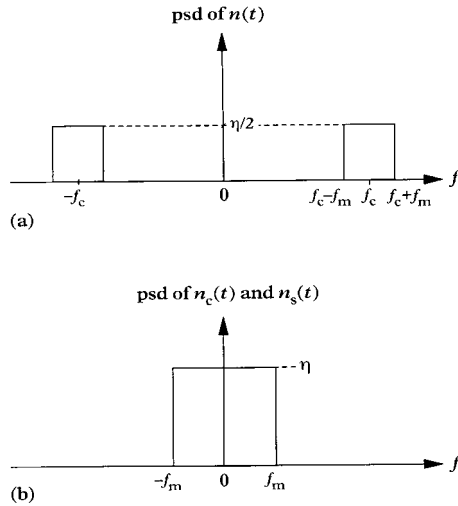

Figure 3.5 (a) Bandpass AWGN Representation. (b) Lowpass AWGN Representation

The bandpass filter shown in Figure 3.4 (also referred to as the pre-detection filter) is used to remove the out of band noise and any harmonic signal terms. At point (1) in figure 3.4, the DSB signal plus noise is given by:

$$m(t) \cos (w_c t) + n_c(t) \cos (w_c t) - n_s(t) \sin (w_c t). \quad (3.20)$$

At point (2), the DSB signal plus noise is multiplied by a synchronous replica of the carrier signal. The resultant is given by:

$$m(t) \cos ^2(w_c t) + n_c(t) \cos ^2(w_c t) - n_s(t) \sin (w_c t) \cos (w_c t) \quad (3.21)$$

$$= \frac{1}{2} m(t)\{1 + \cos (2w_c t)\} + \frac{1}{2} n_c(t)\{1 + \cos (2w_c t)\} - \frac{1}{2} n_s(t) \sin (2w_c t). \quad (3.22)$$

At point (3), the double-frequency terms are removed by the lowpass filter (also referred to as the post-detection filter), and the output will be:

$$\frac{1}{2} m(t) + \frac{1}{2} n_c(t) = m_o(t) + n_o(t). \quad (3.23)$$

Using the definition of the average signal to noise power ratio in Equation (3.4):

$$(S/N)_o = \frac{E\{\frac{1}{4} m^2(t)\}}{E\{\frac{1}{4} n_c^2(t)\}} \quad (3.24)$$

$$(S/N)_o = \frac{E\{m^2(t)\}}{E\{n_c^2(t)\}} \quad (3.25)$$

$$\begin{aligned} E\{n_c^2(t)\} &= \eta B_T \\ &= 2\eta f_m \end{aligned} \quad (3.26)$$

$$\therefore (S/N)_o = \frac{P_m}{2\eta f_m}. \quad (3.27)$$

But:

$$\frac{1}{2} P_m = E\{m^2(t) \cos ^2(w_c t)\} = P_R \quad (3.28)$$

$$\therefore (S/N)_o = \frac{P_R}{\eta f_m} = \gamma. \quad (3.39)$$

For a distortionless channel, the signal to noise ratio is given in terms of the transmitted power, hence:

$$\therefore (S/N)_o = \frac{k^2 P_T}{\eta f_m} = \gamma. \quad (3.30)$$

Therefore, the signal to noise power ratio for DSB-SC systems is identical to that for analogue baseband transmission.

### 3.2.3 Amplitude Modulation (AM)

This is another type of linear modulation which can be generated by adding a large carrier component to a DSB signal. The amplitude modulated signal has the following form:

$$x(t) = [1 + m(t)] \cos (w_c t) \quad (3.31)$$

$$x(t) = \cos (w_c t) + m(t) \cos (w_c t) \quad (3.32)$$

$$\therefore \text{AM} = \text{carrier} + \text{DSB-SC}. \quad (3.33)$$

It can be seen that the envelope of the AM signal resembles the message signal provided that the following conditions are met:

$$f_c \gg f_m \quad \text{and} \quad [1 + m(t)] > 0.$$

An important parameter of an amplitude modulated signal is the modulation index  $m_x$  defined as:

$$m_x = \frac{\text{peak DSB-SC amplitude}}{\text{peak carrier amplitude}}. \quad (3.34)$$

Hence, a more general form of an amplitude modulated signal is:

$$x(t) = [1 + m_x m(t)] \cos (w_c t). \quad (3.35)$$

The message signal can be completely recovered from the AM signal by simply using an envelope detector provided that  $m_x$  does not exceed one. If  $m_x$  does exceed one, then the carrier is said to be overmodulated, which results in envelope distortion and hence envelope detection is not possible in this case.

#### *Transmitted signal power and bandwidth of AM signals*

The transmission bandwidth of an AM signal is the same as that for a DSB-SC:

$$B_T = 2f_m.$$

Using Equation (3.32), the average transmitted power  $P_T$  of an AM signal is:

$$P_T = P_c + \frac{1}{2}P_m. \quad (3.36)$$

where  $P_c$  is the average carrier signal power.

For a sinusoidal carrier with unity amplitude,  $P_c$  equals a half and the average transmitted power is hence given by:

$$P_T = \frac{1}{2} + \frac{1}{2}P_m. \quad (3.37)$$

The power efficiency of an AM signal is given by the ratio of the power which is used to convey information (i.e. the message signal) to the total transmitted power, hence:

$$\text{power efficiency} = \frac{\frac{1}{2}P_m}{\frac{1}{2} + \frac{1}{2}P_m} \quad (3.38)$$

$$= \frac{P_m}{1 + P_m}. \quad (3.39)$$

A more general expression for the power efficiency includes the modulation index  $m_x$ :

$$\text{Power Efficiency} = \mu = \frac{m_x^2 P_m}{1 + m_x^2 P_m}. \quad (3.40)$$

It can be shown that the maximum power efficiency is achieved when the modulation index  $m_x$  is one. For an arbitrary message signal (e.g. a voice signal), the maximum power efficiency is 50% and for a sine wave message signal the maximum power efficiency is 33.3%. We can conclude that AM is power inefficient due to the power  $P_c$  expended in the carrier. Nevertheless, this carrier power is vital for simple amplitude demodulation.

### *Signal to noise performance of AM systems*

The signal to noise performance of AM systems can be derived in a similar fashion as for DSB systems. Only the result is given for

envelope detection (non-coherent modulation) of an AM signal, with the assumption that the signal power at the receiver input is much higher than the inband noise power. The average signal to noise ratio at the output of the receiver is then given by [3.2]:

$$(S/N)_o = \frac{P_R}{\eta f_m} \mu \quad (3.41)$$

$$\therefore (S/N)_o = \mu \gamma \quad (3.42)$$

where  $\mu$  is the power efficiency of the AM signal as given by Equation (3.40) and  $\gamma$  is the equivalent average signal to noise power ratio for analogue baseband transmission. For 100% modulation (i.e.  $m_x = 1$ ) and an arbitrary message signal, the maximum value for  $\mu$  is a half. Hence, the average signal to noise ratio for an AM system is:

$$(S/N)_o \leq \frac{1}{2} \gamma \quad (3.43)$$

which is at least 3 dB poorer than for baseband transmission and for DSB-SC modulation.

### 3.2.4 Single-Sideband (SSB) Modulation

In cellular land mobile radio systems, it is essential that the modulation techniques employed are spectrally efficient. It can be seen from the previous sections that DSB-SC and AM techniques are both wasteful in terms of spectrum since the transmission bandwidth is twice that of the message signal. Furthermore, AM techniques are also wasteful in terms of transmitted power and have a poor signal to noise performance compared with DSB-SC techniques. In SSB modulation, only one of the two sidebands which result in multiplying the message signal  $m(t)$  with the carrier is transmitted. Conceptually, the simplest way of generating a SSB signal is to first generate a DSB signal and then suppress one of the sidebands using a bandpass filter. Coherent demodulation of a SSB signal is possible using a synchronous carrier, in the same way as for a DSB signal.

Modulation and demodulation of SSB signals as described above seem to be simple and straightforward, however, practical implementation of the SSB technique is not trivial for two reasons. First, the modulator needs an ideal bandpass sideband filter with sharp cut-off characteristics which cannot be exactly achieved in practice. Second,



coherent demodulation requires a carrier reference at the receiver which is precisely synchronous with the carrier signal used to generate the modulated message signal. Voice message signals do not contain significant low-frequency components. Consequently, there will be no significant frequency components in the vicinity of the carrier frequency  $f_c$  after modulation and hence the use of 'brickwall' sideband filtering is not really necessary. Alternatively, SSB signals can be generated by a proper phase shifting of the message signal, which does not require a sideband filter. Envelope detection of SSB signals can be employed instead of synchronous demodulation by adding a carrier frequency component to the SSB signal at the transmitter, in the same way described for AM. Nevertheless, this will lead to a waste of transmitted power and to an inferior signal to noise performance.

#### *Transmitted signal power and bandwidth of SSB signals*

The bandwidth  $B_T$  required to transmit a message signal of bandwidth  $f_m$  using SSB modulation is:

$$B_T = f_m. \quad (3.44)$$

The average transmitted power  $P_T$  of a SSB modulated signal can be easily verified to be half that of a SSB-SC signal, provided that the average message signal power is identical in both cases. That is, for a SSB:

$$P_T = \frac{1}{4} P_m. \quad (3.45)$$

#### *Signal to noise performance of SSB systems*

For coherent demodulation of SSB signals, the average signal to noise performance can be derived in the same way as for DSB-SC signals. The average signal to noise ratio at the output of the receiver is given by [3.2]:

$$(S/N)_o = \frac{P_R}{\eta f_m} = \gamma. \quad (3.46)$$

Equation (3.46) indicates that  $(S/N)_o$  for SSB systems is identical to that for baseband and DSB-SC systems, in the presence of white noise.

### 3.2.5 Angle (Non-linear) Modulation

In contrast to the linear modulation techniques discussed in the preceding sections, angle modulation is a non-linear process where the spectral components of the modulated message signal are not related in any simple fashion to the baseband message signal. Considering the sinusoidal carrier given by Equation (3.1), and assuming a constant amplitude such that  $v(t) = V_c$  :

$$x_c(t) = V_c \cos [w_c t + \phi(t)]. \quad (3.47)$$

Angle modulation is achieved by relating  $\phi(t)$  or its derivative to the message signal  $m(t)$ , while keeping the amplitude of the carrier  $V_c$  constant (for convenience, let  $V_c = 1$ ). Hence, an angle modulated signal will have the following general form:

$$x(t) = \cos [w_c t + f(m(t))]. \quad (3.48)$$

The relation between  $\phi(t)$  and  $m(t)$  can take any mathematical form which can lead to many types of angle modulation techniques. However, only two types of angle modulation techniques have proved to be practical: phase modulation (PM) and frequency modulation (FM). In PM,  $\phi(t)$  is linearly related to the message signal  $m(t)$  and in FM the time derivative of  $\phi(t)$  is linearly related to  $m(t)$ . Mathematically:

$$\phi(t) = k_p m(t) \quad \text{for PM} \quad (3.49)$$

$$d\phi/d_t = k_f m(t) \quad \text{for FM} \quad (3.50)$$

where  $\phi(t)$  is the instantaneous phase deviation of  $x(t)$ ,  $d\phi/d_t$  is the instantaneous frequency deviation of  $x(t)$ ,  $k_p$  is the phase deviation constant, expressed in rad/V and,  $k_f$  is the frequency deviation constant, expressed in rad/s/V.

Hence, an angle modulated signal can be expressed in the following forms:

$$x(t) = \cos [w_c t + k_p m(t)] \quad \text{for PM} \quad (3.51)$$

$$x(t) = \cos [w_c t + k_f \int_0^t m(u) du] \quad \text{for FM.} \quad (3.52)$$

*Transmitted signal power and bandwidth of FM signals*

The spectrum of an angle modulated signal for an arbitrary message signal is difficult to describe because of the non-linearity of the angle modulation process. Instead, the spectra for a frequency modulated sinusoidal message signal is usually examined and the result is then generalized for arbitrary message signals. Giving the result only, the bandwidth  $B_T$  required to transmit a message signal of bandwidth  $f_m$  using FM modulation is [3.2]:

$$B_T = 2(\beta + 1) f_m. \quad (3.53)$$

The above expression is referred to as Carson's rule and  $\beta$  is defined as follows:

$$\beta = \frac{\text{peak frequency deviation}}{\text{message signal bandwidth}} = \frac{f_\Delta}{f_m}. \quad (3.54)$$

The peak frequency deviation is given by Equation (3.50), when the absolute value of  $m(t)$  is maximum. Based on the value of  $\beta$ , FM signals fall into two categories as follows.

$$(a) \quad \text{For } \beta \ll 1, B_T = 2 f_m. \quad (3.55)$$

This is called narrowband FM (NBFM), and the transmission bandwidth in this case is the same as for DSB and AM. NBFM modulation has no inherent advantages over linear modulation techniques.

$$(b) \quad \text{For } \beta \gg 1, B_T = 2\beta f_m = 2 f_\Delta. \quad (3.56)$$

In this case, the FM signal is called a wideband FM (WBFM) signal. It is obvious that the transmission bandwidth of a WBFM signal is much larger than  $f_m$  and is dependent upon the value of  $\beta$  (or  $f_\Delta$ ).

From equation (3.52), the average normalized transmitted power of the FM modulated signal  $m(t)$  is:

$$\begin{aligned} P_T &= E\{x^2(t)\} \\ P_T &= \frac{1}{2}. \end{aligned} \quad (3.57)$$

Hence, the average transmitted power of a frequency modulated signal is a function of the amplitude of the carrier signal and is

independent of the message signal  $m(t)$ . This is an expected result since the message signal causes only the 'angle' of the carrier to change without altering its amplitude.

### *Signal to noise performance of FM systems*

The signal to noise ratio of a FM system is taken as the ratio of the mean signal power without noise to the mean noise power in the presence of an unmodulated carrier. Hence, assuming that the output noise power can be calculated independently of the modulating signal power yields the following result [3.2]:

$$(S/N)_o = 3\beta^2 \gamma P_m. \quad (3.58)$$

The above expression is valid provided that the signal power at the receiver (detector) is much higher than the noise power. This is referred to as the threshold effect of FM systems, below which the signal to noise performance of the FM system deteriorates markedly. From Equation (3.58), it is obvious that  $(S/N)_o$  can be increased by increasing  $\beta$  (or  $f_\Delta$ ), without having to increase the transmitted power. Increasing  $\beta$  will increase the transmission bandwidth  $B_T$  as shown in Equation (3.56). Thus, in WBFM systems, it is possible to trade off bandwidth for improved signal to noise performance without having to increase the transmitted signal power, provided that the system is operating above threshold.

### **3.2.6 General Comparison of Various Analogue Modulation Techniques**

In the previous section, an overview of the basic analogue modulation techniques was presented. A general comparison of the various analogue modulation techniques in terms of transmission bandwidth and the average signal to noise performance is given in Table 3.1. It is assumed that a normalized voice message signal is used, such that:

$$-1 \leq m(t) \leq 1 \quad \text{and} \quad E\{m^2(t)\} = P_m = \frac{1}{2}.$$

The transmission bandwidth is vital for spectral efficiency considerations and the signal to noise performance reflects the signal quality at the receiver. Equipment complexity is not considered since spectral

**Table 3.1** General Comparison of Various Analogue Modulation Techniques

Modulation	$B_T$	$(S/N)_0$	Suitability to Cellular Systems
Baseband	$f_m$	$\gamma$	—
DSB-SC	$2 f_m$	$\gamma$	Wasteful of bandwidth
AM	$2 f_m$	$\leq \gamma/3$	Wasteful of power and bandwidth and poor $(S/N)_0$ performance
SSB	$f_m$	$\gamma$	Spectrally efficient and good $(S/N)_0$ performance
WBFM	$2(\beta + 1) f_m$	$3/2 \beta^2 \gamma$	Superior $(S/N)_0$ performance but excessive use of bandwidth
NBFM	$2 f_m$	$\ll \gamma$	Same bandwidth as DSB and AM but $(S/N)_0$ performance is far inferior

efficiency is of prime importance in cellular land mobile radio systems. From Table 3.1, amongst linear modulation techniques, SSB is both spectrally efficient and has a good signal to noise performance. On the other hand, FM has a superior signal to noise performance over all other modulation techniques. However, the excessive use of bandwidth in FM systems is yet to be justified for cellular systems. Furthermore, the FM system has a superior signal to noise performance above threshold but for small signal to noise conditions the FM system may actually be inferior to other linear modulation techniques.

The above comparison is incomplete and can only show the potential spectral efficiency of various modulation techniques because of the idealized conditions assumed for their operation. A more realistic approach is first to establish a rigorous and comprehensive set of criteria with which the spectral efficiency of various modulation techniques can be evaluated in terms of their important parameters. Second, the spectral efficiency of different modulation techniques should be considered within the cellular environment. In the following, the spectral efficiency measure in terms of Channels/MHz/km<sup>2</sup> is used to devise a method to evaluate the spectral efficiency of various modulation techniques when implemented by cellular systems.

### 3.3 MATHEMATICAL INTERPRETATION OF CHANNELS/MHZ/KM<sup>2</sup>

Consider a cellular land mobile radio system with a service area divided into a number of clusters of equal area, every cluster is

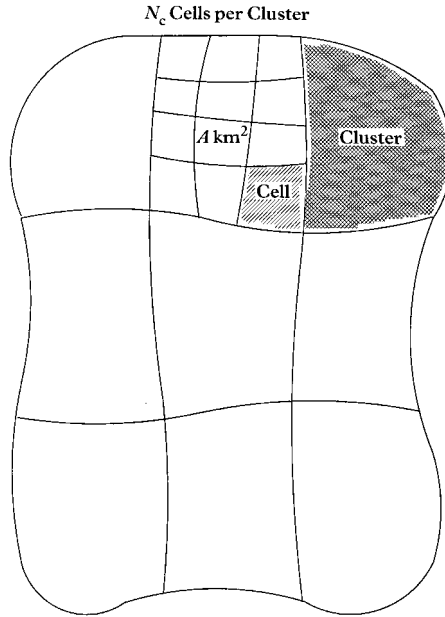

Figure 3.6 Service Area Divided into Cells and Clusters

sub-divided into  $N_c$  cells of equal area, each is  $A \text{ km}^2$  (see Figure 3.6). A total bandwidth of  $B_t$  MHz is assumed to be available to the system and this total bandwidth is divided into voice channels, each is  $B_c$  MHz in bandwidth. In this case, the number of channels available to the system is given by  $B_t/B_c$ , and  $B_c$  will be mainly governed by the modulation technique employed. Adopting the measure of spectral efficiency in cellular systems as Channels/MHz/ $\text{km}^2$ , the spectral efficiency of a modulation technique can be mathematically interpreted by the following equations:

$$\eta_M = \frac{\text{total number of channels available to the system}}{\text{total available bandwidth} \times \text{cluster area}} \quad (3.59)$$

$$\eta_M = \frac{B_t/B_c}{B_t(N_c A)} \quad (3.60)$$

$$\eta_M = \frac{1}{B_c N_c A} \quad (3.61)$$

where  $\eta_M$  is called the modulation efficiency of the cellular system, expressed in terms of Channels/MHz/ $\text{km}^2$ .

From the above equations, we note the following:

(a) For point-to-point and non-cellular radio systems, the spectral efficiency can be simply presented in terms of the number of channels available to the system and is given by  $B_t/B_c$  (channels). In such systems the spectral efficiency is a function of the channel spacing  $B_c$  only.

(b) In cellular systems, the modulation efficiency measured in Channels/MHz/km<sup>2</sup> is inversely proportional to the channel spacing  $B_c$ . The modulation efficiency is independent of the total bandwidth  $B_t$  allocated to the cellular system, excluding multiple access efficiency considerations.

(c) The spectral efficiency of a cellular system is inversely proportional to the cluster area given by  $(N_c A)$ . This is because the cluster is the repetition unit in cellular systems and not the cell. Consequently, the more clusters a cellular system can accommodate in a given service area, the more spectrally efficient it is considered to be.

(d) The modulation efficiency  $\eta_M$  can be maximized by minimising  $B_c$ ,  $N_c$  or  $A$ . The channel spacing  $B_c$  is dependant on the modulation technique employed by the cellular system. The theoretical minimum of  $N_c$  is one and in this case one cell per cluster will give rise to maximum efficiency, as far as  $N_c$  is concerned. Furthermore, minimizing the cell area will depend upon several factors such as the transmitted power, hand-off rate and the availability and tolerance of cell sites.

### 3.4 CALCULATION OF THE NUMBER OF CELLS PER CLUSTER $N_c$

From the previous section, the spectral efficiency of a modulation technique within cellular systems is shown to be a function of three parameters – channel spacing  $B_c$ , number of cells per cluster  $N_c$  and cell area  $A$ . It will be shown that  $N_c$  is a very important parameter which relates to some parameters of the modulation technique employed. On the other hand,  $N_c$  depends on the cell shape as well as the model used to calculate the co-channel interference in the system.

### 3.4.1 Cellular Geometry

The main reason for defining cells in a cellular land mobile radio system is to outline areas in which specific channels and specific cell sites are used. However, designers realize that visualizing all cells as having the same geometrical shape helps to ease the design of cellular systems, not only in locating transmitter sites relative to one another and making economical use of equipment, but it also makes the adaptation to traffic much easier. From our viewpoint, cellular geometry helps to ease the assessment of spectral efficiency of various cellular systems, in particular to calculate the significant co-channel interference in the system.

### 3.4.2 Cell Shapes

There are only certain patterns of cells or tessellations which can be repeated over a plane: the regular hexagon, the square and the triangle. The regular hexagon is favoured by system designers for the following reasons:

- (a) It provides the best approximation to the circular omnidirectional radio patterns achieved in practice.
- (b) It is more economical to use, since a hexagonal layout requires fewer cells and hence fewer base stations.
- (c) It combines ease of geometry to the practical realization of overlapping circles.

### 3.4.3 Principles of Hexagonal Geometry

There are several objectives for describing the fundamentals of hexagonal geometry. First, to outline clusters of cells and calculate the number of cells per cluster  $N_c$  in terms of other parameters of the cellular system. Second, to locate co-channel cells and calculate the co-channel cell separation  $D$  in terms of  $N_c$ . To be able to do this, the co-channel re-use ratio is defined as:

$$\text{co-channel re-use ratio} = \frac{\text{minimum co-channel cell separation}}{\text{cell radius}} \quad (3.62)$$

$$Q = \frac{D}{R}. \quad (3.63)$$



It can be seen that the co-channel interference can be reduced if  $Q$  is made large enough. For this reason,  $Q$  is also referred to as the co-channel interference reduction factor [3.5]. This is an important and useful factor in cellular land mobile radio systems. For a fixed cell size, co-channel interference is independent of the transmitted power of the base station in each cell. In fact, co-channel interference is a function of  $Q$  only, as will be shown later.

Figure 3.7 shows a cellular pattern using regular hexagons and a convenient set of axes intersecting at  $60^\circ$  [3.6]. Clearly:

$$R \cos 30^\circ = \frac{1}{2} \quad \text{giving } R = \frac{1}{\sqrt{3}}. \quad (3.64)$$

To find the distance  $r$  of a point  $P(u, v)$  from the origin and using  $x$ - $y$  to  $u$ - $v$  co-ordinates transformations:

$$r^2 = x^2 + y^2$$

$$x = u \cos 30^\circ$$

and

$$y = v + u \sin 30^\circ.$$

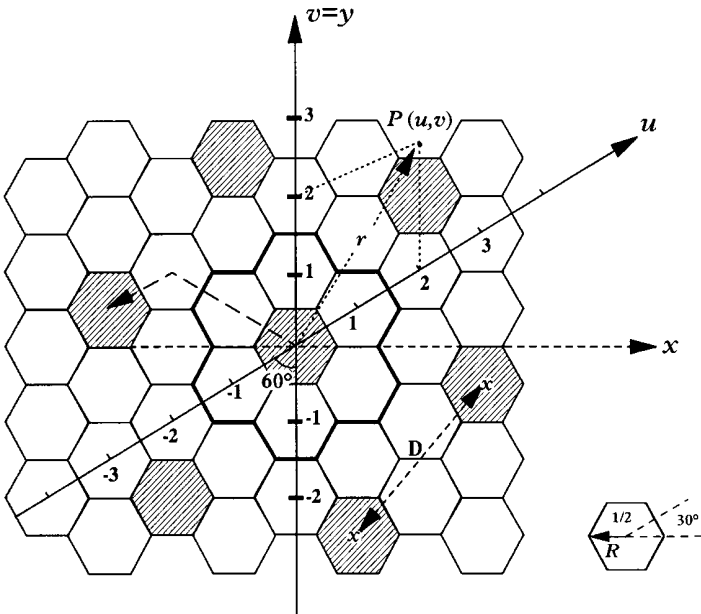

Figure 3.7 Hexagonal Cell Geometry with a Convenient Set of Axes

Hence:

$$r = (v^2 + uv + u^2)^{1/2}. \quad (3.65)$$

Using Equation (3.65) to locate co-channel cells, we start from a reference cell and move  $i$  hexagons along the  $u$ -axis then  $j$  hexagons along the  $v$ -axis. Hence, the distance  $D$  between co-channel cells in adjacent clusters is given by:

$$D = (i^2 + ij + j^2)^{1/2}. \quad (3.66)$$

The number of cells  $N_c$  in a cluster is proportional to  $D^2$ , i.e.  $N_c \propto D^2$  and it is shown in [3.6] that:

$$N_c = D^2 \quad \text{precisely} \quad (3.67)$$

$$\therefore N_c = i^2 + ij + j^2 \quad (3.68)$$

Since  $i$  and  $j$  can only take integer values, Equation (3.68) suggests that  $N_c$  can only take particular values, e.g.  $N_c = 1, 3, 4, 7, 9, 12, 13$ , etc., are possible values of  $N_c$ . In Figure 3.7, the heavy border outlines a cluster of seven cells and the shaded cells are co-channel cells (i.e. using the same set of voice channels with the same radio frequencies). In fact, there are precisely six proximate co-channel cells for all values of  $N_c$ .

*Relationship between the co-channel re-use ratio  $D/R$  and the number of cells per cluster  $N_c$*

From Equations (3.64) and (3.66):

$$D/R = \{3(i^2 + ij + j^2)\}^{1/2}$$

and using Equation (3.68):

$$D/R = \sqrt{3N_c}. \quad (3.69)$$

Hence, the modulation efficiency is given in terms of  $D/R$  as follows:

$$\eta_M = \frac{3}{B_c(D/R)^2 A}. \quad (3.70)$$

In practice, co-channel interference considerations influence the choice of the number of cells per cluster. Making  $D/R$  smaller leads to a spectrally more efficient cellular system, a result confirmed by Equation (3.70). However, for a better transmission quality in terms of signal to co-channel interference,  $D/R$  needs to be large. A trade off between the two objectives – spectral efficiency and transmission quality – must be achieved when comparing different modulation systems in terms of spectral efficiency. Hence, we conclude that to compare different modulation systems in terms of spectral efficiency, a certain voice quality standard has to be set and user satisfaction has to be achieved.

### **3.5 RELATIONSHIP BETWEEN CO-CHANNEL RE-USE RATIO AND PROTECTION RATIO IN A CELLULAR SYSTEM**

The spectral efficiency of a cellular land mobile radio system employing a particular modulation technique is a function of three main system parameters: channel spacing, cell area and the co-channel re-use ratio. It is of great importance, however, to relate the spectral efficiency of modulation techniques to the speech quality experienced by the users in the cellular system. The speech quality is influenced by the signal to co-channel interference protection ratio determined by the modulation technique used. To help establish the relationship between the co-channel re-use ratio  $D/R$  and the protection ratio in a cellular system, the protection ratio needs to be defined.

#### **3.5.1 Definition of Protection Ratio**

In general terms, the co-channel protection ratio of a cellular land mobile radio system can be defined as 'its capability to reject co-channel interference'. In [3.7], co-channel protection ratio was defined as "the minimum ratio of wanted to unwanted signal level for satisfactory reception". In other words, it is the ability of a given modulation system to 'discriminate' the desired signal from the undesired interferences such that satisfactory signal reception is achieved. The protection ratio is either a ratio of voltages or signal powers, and in the latter case it is presented in decibels. Another definition of the protection ratio is "The level at which 75% of the users state that the voice quality is either good or excellent in 90% of the service area"

[3.6]. The World Administrative Radio Conference, Geneva, 1979, defined the protection ratio as “the minimum value of the wanted-to-unwanted signal ratio, usually expressed in decibels, at the receiver input determined under specified conditions such that a specified quality of the wanted signal is achieved at the receiver output” [3.8]. This ratio may have different values according to the type of modulation system used. The latter definition of protection ratio appears to be a comprehensive one. Nevertheless, it is necessary to have a standard set of conditions under which the protection ratio is assessed as well as a standard for voice quality. This will ensure that consistent values of protection ratios are obtained. More details of the evaluation of the co-channel protection ratio can be found in Chapter 7.

It is worth mentioning that in cellular land mobile radio systems the co-channel interference is actually the limiting factor in their efficiency and performance and not the total noise in the system. This is because the unwanted signal power is very much higher than the total noise power in the system (i.e. thermal, man-made and indigenous noise), hence the latter can be ignored. Mathematically:

$$\text{protection ratio, } a = \frac{S}{(I + N_s)} \quad (3.71)$$

$$\therefore \text{protection ratio, } a \approx \frac{S}{I} \quad \text{for } I \gg N_s \quad (3.72)$$

where  $S$  is the wanted signal power,  $I$  is the unwanted co-channel interfering signal power and  $N_s$  is the total inband noise power in the system.

A more precise mathematical representation of the protection ratio can also be found in Chapter 7.

The co-channel protection ratio is a valuable measure of the performance of a modulation technique in cellular systems and it can indeed influence its spectral efficiency. We now need to look at the co-channel interference models.

### 3.6 CO-CHANNEL INTERFERENCE MODELS

To establish a relationship between the protection ratio of a modulation system and the co-channel re-use distance, it is necessary to model the cellular land mobile radio system in order to include the propagation effects on the radio signal. It is also necessary to model the relative geographical locations of the transmitters and receivers in

the system so as to be able to predict all the significant co-channel interference affecting the desired signal.

In general, two main categories of co-channel interference models can be visualized. The first category is a geographical one, where the models are constructed by considering the relative geographical locations of the transmitters and receivers, considering different possible numbers of interferers in the cellular system. The second category is a statistically based group of models, in which the propagation effects, mainly fading and shadowing, are included in a statistical fashion. Both categories of models are based on the following general assumptions:

- (a) A cellular land mobile radio system with regular hexagonal cell shapes is adopted for the reasons mentioned earlier (Section 3.4.2).
- (b) Base stations are located at cell centres and employ omnidirectional antennas.
- (c) Considering signal path loss: the long-term median value of the signal power decreases with radial distance from the base station and is inversely proportional to some power  $\alpha$  of the distance. Analytical results over a 'flat earth' by Bullington [3.9] show that the power received by the mobile station antenna is inversely proportional to the fourth power of its distance from the base station. This is often referred to as 'the inverse fourth-power dependence of mean received power on range'. However, field measurements at approximately 900 MHz by independent workers in three different cities – Kanto the heart of Tokyo [3.10], New York [3.11] and Philadelphia [3.12] – showed that  $\alpha$  is always less than four and greater than two. A full and more recent survey on various propagation models for mobile radio systems in the 800/900 MHz range can be found in [3.13]. In general,  $\alpha$  is dependent upon the nature of the terrain and degree of urbanization and usually has values between three and four [3.14].
- (d) In both categories of models, only co-channel interference is considered. An acceptable adjacent channel interference would be between 60 dB [3.5] and 70 dB [3.15]. The adjacent channel interference effect can be substantially reduced by the use of an intermediate frequency (IF) filter at the receiver with sharp cut-off characteristics. The adjacent channel interference can be reduced even further with the use of a good frequency allocation plan [3.16], which ensures frequency separation between adjacent channels within each cell in the system.
- (e) No intermodulation products will be produced from a base station antenna with a large number of frequency channels. The channel

combiner connected to the antenna is assumed to be well matched to each channel load impedance.

(f) For various types of modulation techniques, the long-term and the short-term frequency stability can be maintained.

(g) Techniques to improve signal quality such as diversity signal reception, companding, pre-emphasis/de-emphasis, automatic frequency control (AFC) and automatic gain control (AGC), etc. are assumed to be equally applicable to all systems and hence are not included as part of the models. Nonetheless, the effect of employing such techniques will be reflected by the value of the protection ratio. Also, for techniques which are exclusive to a particular modulation system/systems, again that will influence the value of the protection ratio and hence will be tacitly accounted for.

(h) Co-channel interference is assumed to be independent of the actual amount of transmitted power of base stations. This follows from the assumption that the sizes of all cells in a given cellular system are roughly the same.

(i) The interference from base station/stations to a mobile station is considered as the likely worst case. This is because the power radiated from mobile stations is very much lower than that radiated by base stations. Therefore, the interfering effect of mobile stations on base stations can be ignored. Furthermore, the base stations can afford to operate more complex equipment to eliminate interference.

(j) Although these models are suitable for cellular systems operating in the 900/1000 MHz frequency band, the models can be adapted for other systems operating in other frequency bands provided that the propagation conditions in such bands are taken into account.

### 3.6.1 General Features of the Geographical Models

The models in this category have the following special features:

(a) The models are built depending on the relative geographical locations of the serving and interfering base stations with respect to the mobile station.

(b) The main difference between various models within this category is the number of active co-channel interferers in the system which are taken into account.

(c) The models in this category account for the signal path loss due to free space and propagation loss over a 'flat earth'. That is to say, the long-term median value of the signal power decreases with radial distance from the base station and is inversely proportional to some power  $\alpha$  of the distance. As mentioned earlier,  $\alpha$  can take values between three and four depending on the nature of the terrain and the urbanization degree. Assuming a perfectly flat earth and a relatively small base station antenna heights,  $\alpha$  is well approximated by a value of four [3.9, 3.17]. For more accurate values of  $\alpha$ , field signal variation measurements need to be carried out, otherwise, a value of 3.5 for  $\alpha$  seems to be a good practical compromise.

(d) The models in this category do not account for additional signal loss due to fading and/or shadowing. Nevertheless, these effects can be added by modifying the models once they have been fully developed. This is accomplished by measuring the protection ratio of the system under fading and/or shadowing conditions. Hence, the value of the protection ratio which appears as part of these models will contain the necessary information regarding the fading and/or shadowing effects on the signal.

There are three models which belong to this category: geographical model with one interferer, geographical model with six interferers and geographical model with many tiers of interferers. These models are described in detail later in this chapter.

### 3.6.2 General Features of the Statistical Models

The statistical models have the following special features:

(a) All the models in this category are based on a one-interferer situation.

(b) The received signal has an amplitude which varies with a Rayleigh distribution ( fading) about a slowly varying mean. Fading is typically caused by the signal being reflected from various types of both stationary and moving scatterers. In this case fading results because, in some mobile positions, phases of the signal arriving from different paths interfere destructively while in other positions the phases add constructively. Theoretical [3.17] and practical [3.18] studies suggest that the statistics of fading closely approximate a Rayleigh amplitude distribution.

- (c) The slow variation in the signal mean follows a log-normal distribution (shadowing). Shadowing results from the signal being blocked by large structures or hills and mountains. It is referred to as log-normal fading since the received signal level measured in decibels is best described by a normal distribution with a standard deviation in the range 5–10 dB [3.19, 3.20].
- (d) The slowly varying signal mean is itself an inverse function of the distance between the transmitter and the receiver (the inverse  $\alpha$  power law).
- (e) With fading and shadowing, co-channel interference can occur anywhere, even close to the serving base station, a view which sharply contrasts with the geographical models, in which fading and shadowing are ignored and interference appears to occur in a well defined area around the base station/stations.
- (f) Basic model. Suppose that the signal e.m.f. received at the mobile station from the serving base station  $T_s$  is  $y_s$  and from the interfering base station  $T_i$  is  $y_i$ , then for satisfactory reception it is necessary that:

$$y_s \geq ry_i \quad (3.73)$$

where  $r$  is the protection ratio. (N.B.  $r$  is the ratio of the wanted signal amplitude to the interfering signal amplitude, which is not as used before as the ratio of the wanted signal power to the interfering signal power.) With the statistical models, we need to calculate the probability of  $y_s$  being greater than  $y_i$  by the amount of protection ratio,  $r$ . Mathematically:

$$P[y_s \geq ry_i]. \quad (3.74)$$

There are three models which belong to the statistical category – fading only, shadowing only and fading and shadowing statistical models. These are described in more detail later.

### 3.6.3 Model I: Geographical Model with One Interferer

In this basic model, only one co-channel interferer is taken into account. This model is depicted in Figure 3.8(a), where  $T_s$  is the serving base station,  $T_i$  is the interfering base station and  $D$  and  $R$  have their usual meanings. Consider the worst case, when the



mobile station is nearest to the interfering base station and furthest from its own serving base station (i.e. at the edge of the cell towards the co-channel interferer). Also, assume that the long-term median value of the signal power decreases with radial distance from the base station and is inversely proportional to some power  $\alpha$  of the distance. Then, at the mobile station, the desired signal power  $S$  received from the serving base station  $T_s$  is inversely proportional to  $R^\alpha$ , i.e.

$$S \propto \frac{1}{R^\alpha}. \tag{3.75}$$

Similarly, the undesired interfering signal power  $I$  received from the interfering base station  $T_i$  is inversely proportional to  $(D - R)^\alpha$ , i.e.

$$I \propto \frac{1}{(D - R)^\alpha}. \tag{3.76}$$

Hence, combining the results in Equations (3.75) and (3.76) yields

$$\frac{S}{I} = \left[ \frac{(D - R)}{R} \right]^\alpha \tag{3.77}$$

$$\therefore \frac{D}{R} = \left( \frac{S}{I} \right)^{1/\alpha} + 1. \tag{3.78}$$

Also, using Equation (3.69):  $D = \sqrt{(3N_c)}$ , then:

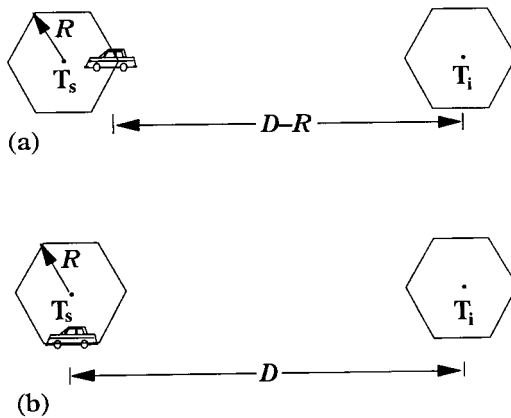
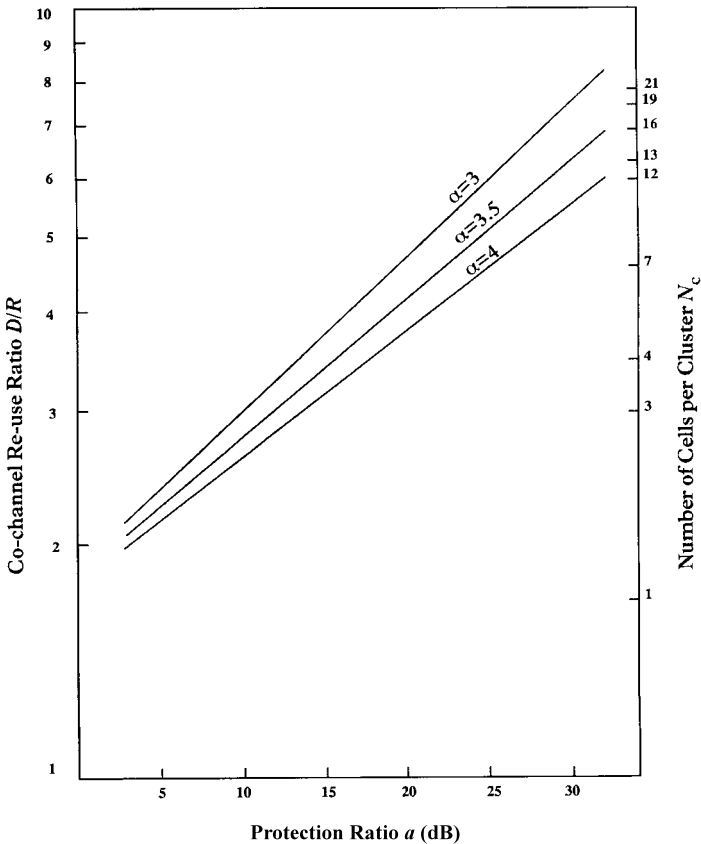

**Figure 3.8** Model I: Geographical Model with One Interferer.  $T_s$ , Serving Base Station;  $T_i$ , Interfering Base Station. (a) Worst Case. (b) Average Case

$$N_c = \frac{[(S/I)^{1/\alpha} + 1]^2}{3} \quad (3.79)$$

where  $S/I$  is the protection ratio,  $a$ .

The relations  $D/R$  versus  $S/I$  (protection ratio,  $a$ ) in decibels, and  $N_c$  versus  $S/I$  are illustrated in Figure 3.9, for different possible values of  $\alpha$ . From Equation (3.61), the spectral efficiency is inversely proportional to the number of cells per cluster and hence, the graphs in Figure 3.9 show that for higher values of  $\alpha$  it is possible to employ a smaller number of cells per cluster and consequently have a higher spectral efficiency, for a given modulation technique. Unfortunately,  $\alpha$  is dependent upon the nature of the terrain and urbanization



**Figure 3.9** Model I: Geographical Model with One Interferer. Protection Ratio Versus  $D/R$  and  $N_c$

degree in the vicinity of the base and mobile stations and the value of  $\alpha$  cannot be actually controlled by the system designer. Theoretical studies [3.9] show that  $\alpha$  reaches the value of four provided that the antenna height of the base station is relatively small compared with the distance between the base and mobile stations. This is also confirmed by field measurements [3.10]. In this model, the mobile station is furthest from its own serving station; hence, the height of the base station antenna can be considered to be small compared with the distance of the mobile from the base station and  $\alpha$  is well approximated by four.

Equation (3.79) gives the relationship between the protection ratio and the number of cells per cluster needed for a satisfactory signal reception. It shows that the spectral efficiency is higher for lower values of protection ratios which are dependent on the modulation techniques used. In theory,  $N_c$  can only take particular integer values and consequently,  $N_c$  is a discontinuous function of the protection ratio. This is illustrated in Figure 3.10 for  $\alpha = 4$ . Furthermore, since

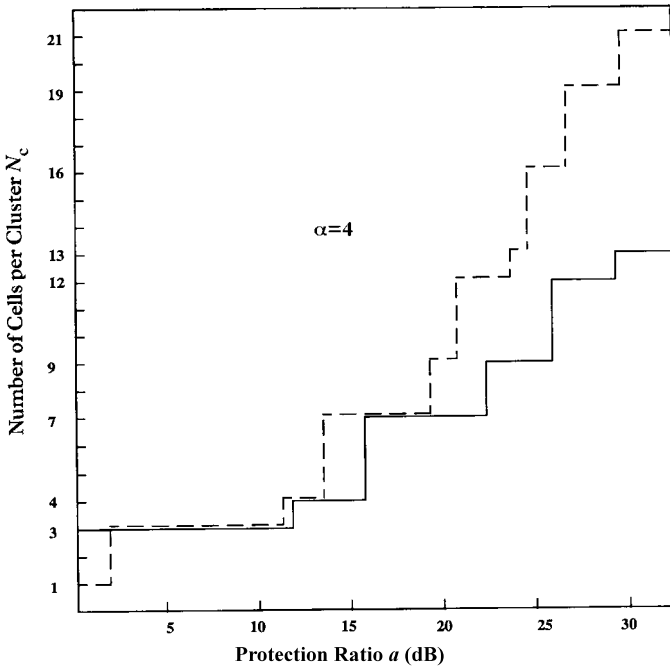

**Figure 3.10** Protection Ratio as a Discontinuous Function of  $N_c$ .—, Geographical Model with One Interferer; - - -, Geographical Model with Six Interferers

spectral efficiency is inversely proportional to  $N_c$ , it follows that spectral efficiency is a discontinuous function of the protection ratio. This leads to the following implications:

(a) The precise value of the protection ratio of a modulation technique might not be as crucial in assessing its spectral efficiency as it is thought.

(b) A slight advantage in the protection ratio of one modulation technique over another does not necessarily imply a higher spectral efficiency. To give an example from Figure 3.10, a modulation technique with a 16 dB protection ratio might have a better voice quality over a modulation technique with a 22 dB protection ratio; however, no spectral efficiency advantage is achieved because of the protection ratio since both systems require seven cells per cluster for their operation.

The previous result was obtained considering the worst case situation. Instead, an average case situation can be developed when the mobile station is at an average distance  $D$  from the interfering base station but furthest from its own serving base station (see Figure 3.8(b)). In this case Equations (3.78) and (3.79) become:

$$\frac{D}{R} = \left(\frac{S}{I}\right)^{1/\alpha} \quad (3.80)$$

$$N_c = \frac{1}{3} \left(\frac{S}{I}\right)^{2/\alpha}. \quad (3.81)$$

### 3.6.4 Model II: Geographical Model with Six Interferers

In this model, the interference from the first tier co-channel cells (i.e. next nearest co-channel cells) is taken into account. In a fully developed hexagon-shaped cellular system, there are always six co-channel cells in the first tier regardless of the number of cells per cluster [3.6]. It is assumed that all six co-channel interfering cells are active as in a busy hour situation. It is also assumed that interference from second and higher order tiers is negligible. This model is depicted in Figure 3.11, where  $T_{i_1}$ – $T_{i_6}$  are the six closest interfering base stations. Consider the average case, when the mobile station is furthest from its own serving base station and is at an average distance  $D$  from all six interfering base stations. Then, at the mobile station:

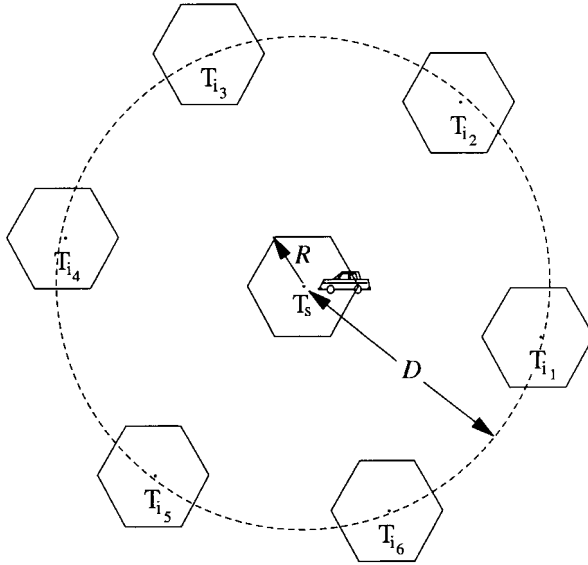

**Figure 3.11** Model II: Geographical Model with Six Interferers.  $T_s$ , Serving Base Station;  $T_{i_1} - T_{i_6}$ , Interfering Base Stations

$$S \propto \frac{1}{R^\alpha} \tag{3.82}$$

$$I \propto 6 \left( \frac{1}{D^\alpha} \right). \tag{3.83}$$

Hence, the signal to interference ratio is given by:

$$\frac{S}{I} = \frac{1}{6} \left( \frac{D}{R} \right)^\alpha \tag{3.84}$$

$$\therefore \frac{D}{R} = \left[ 6 \left( \frac{S}{I} \right) \right]^{1/\alpha} \tag{3.85}$$

and

$$N_c = \frac{\left[ 6 \left( \frac{S}{I} \right) \right]^{2/\alpha}}{3} \tag{3.86}$$

where  $S/I$  is the protection ratio and is given by:

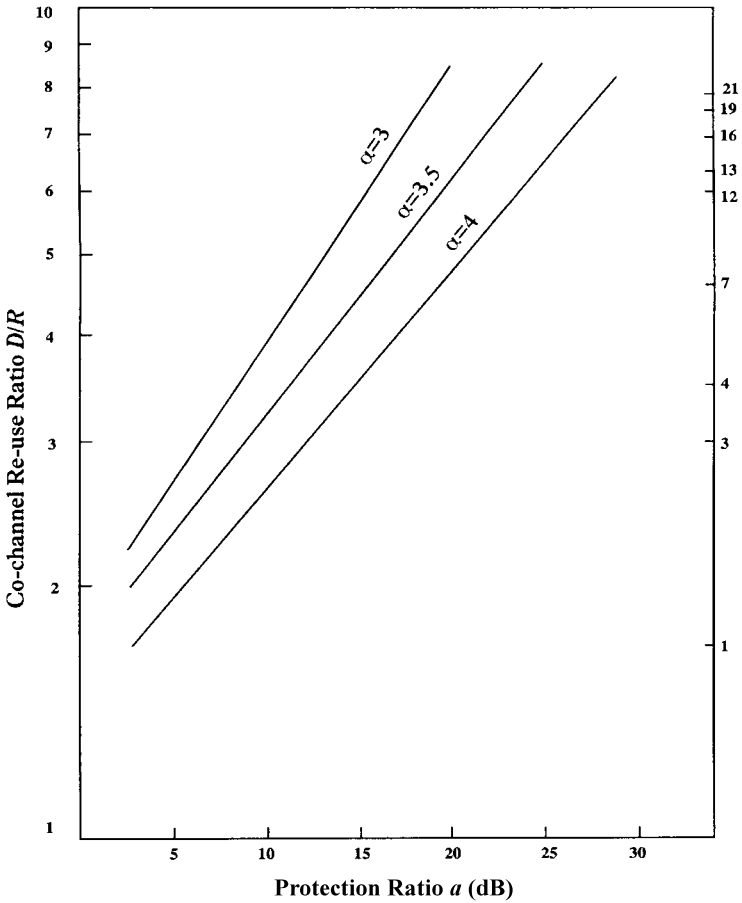

Figure 3.12 Model II: Geographical Model with Six Interferers. Protection Ratio Versus  $D/R$  and  $N_c$

$$\frac{S}{I} = \frac{S}{\sum_{n=1}^6 I_n} \tag{3.87}$$

where  $I_n$  is the interference from the  $n$ th co-channel cell.

The relations  $D/R$  versus  $S/I$  in decibels, and  $N_c$  versus  $S/I$  are illustrated in Figure 3.12, for different possible values of  $\alpha$ . Also, Figure 3.10 shows  $N_c$  as a discontinuous function of the protection ratio, for  $\alpha = 4$ .

**3.6.5 Model III: Geographical Model with Several Tiers of Interferers**

In this model, the co-channel interference from several tiers of co-channel cells is considered. In a fully equipped hexagon-shaped cellular system, there are always  $6m$  co-channel cells in the  $m$ th tier, regardless of the number of cells per cluster. It is assumed that all co-channel interfering base stations, up to the  $m$ th tier considered, are active as in a busy hour situation. It is also assumed that the interference from cells in the higher order tiers (i.e. the  $(m + 1)$ th tier onwards) is negligible. This model is depicted in Figure 3.13, where  $R$  and  $D$  have their usual meanings. For a hexagonal cellular system, the average signal to interference ratio measured at a distance  $R$  from its own serving station can be found in [3.21] and is given by the following relation:

$$\frac{S}{I} = \frac{(3N_c)^{\alpha/2}}{6 \sum_{t=1}^T \sum_{u=0}^{t-1} \frac{1}{(t^2 + u^2 - tu)^{\alpha/2}}}. \tag{3.88}$$

Hence, the following relations can be deduced:

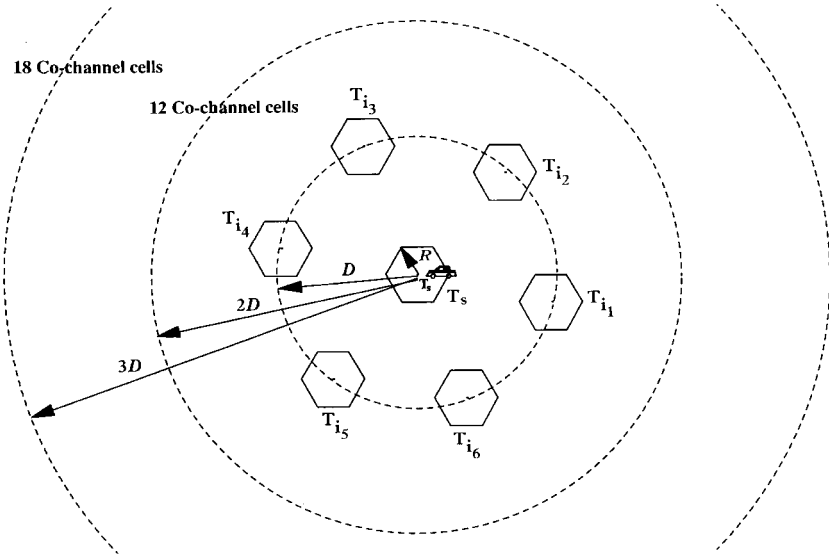

**Figure 3.13** Model III: Geographical Model with Several Tiers of Interferers

$$\frac{S}{I} = \frac{\left(\frac{D}{R}\right)^\alpha}{6 \sum_{t=1}^T \sum_{u=0}^{t-1} \frac{1}{(t^2 + u^2 - tu)^{\alpha/2}}} \quad (3.89)$$

$$\therefore \frac{D}{R} = \left\{ 6 \left(\frac{S}{I}\right) \sum_{t=1}^T \sum_{u=0}^{t-1} \frac{1}{(t^2 + u^2 - tu)^{\alpha/2}} \right\}^{1/\alpha} \quad (3.90)$$

and

$$N_c = \frac{\left\{ 6 \left(\frac{S}{I}\right) \sum_{t=1}^T \sum_{u=0}^{t-1} \frac{1}{(t^2 + u^2 - tu)^{\alpha/2}} \right\}^{2/\alpha}}{3} \quad (3.91)$$

where  $T$  is the number of tiers of co-channel interfering cells considered. Also, the normalized location of a unit cluster consisting of six base stations at equal distances from the serving base station is expressed by  $(t, u)$ . For example, the fourth tier can be expressed by using four unit clusters:

$$(t, u) = (4, 0), (4, 1), (4, 2) \text{ and } (4, 3).$$

Using Equation (3.90), the relationship between  $D/R$  and  $S/I$  can be established for different numbers of tiers of interference. Similarly, the relation between  $N_c$  and  $S/I$  can be established for different numbers of tiers of interference using Equation (3.91). The summation is evaluated for  $\alpha = 4$ , without affecting the generality of the results.

(i) Considering only the first tier of interference with six co-channel cells.

In this case,  $T = 1$  and  $(t, u) = (1, 0)$ .

$$\frac{D}{R} = \left[ 6 \left(\frac{S}{I}\right) \right]^{1/\alpha} \quad (3.92)$$

and

$$N_c = \frac{\left[ 6 \left(\frac{S}{I}\right) \right]^{1/\alpha}}{3}. \quad (3.93)$$

The above result agrees with the previous geographical model with six interferers.



(ii) Considering two tiers of interference with a total of 18 co-channel cells.

In this case,  $T = 2$  and  $(t, u) = (2, 0)$  and  $(2, 1)$ .

$$\frac{D}{R} = \left[ 7.04 \left( \frac{S}{I} \right) \right]^{1/\alpha} \quad (3.94)$$

and

$$N_c = \frac{[7.04 \left( \frac{S}{I} \right)]^{2/\alpha}}{3}. \quad (3.95)$$

(iii) Considering three tiers of interference with a total of 36 co-channel cells.

In this case,  $T = 3$  and  $(t, u) = (3, 0)$ ,  $(3, 1)$  and  $(3, 2)$ .

$$\frac{D}{R} = \left[ 7.36 \left( \frac{S}{I} \right) \right]^{1/\alpha} \quad (3.96)$$

and

$$N_c = \frac{[7.36 \left( \frac{S}{I} \right)]^{2/\alpha}}{3}. \quad (3.97)$$

(iv) Considering four tiers of interference with a total of 60 co-channel cells.

In this case,  $T = 4$  and  $(t, u) = (4, 0)$ ,  $(4, 1)$ ,  $(4, 2)$  and  $(4, 3)$ .

$$\frac{D}{R} = \left[ 7.50 \left( \frac{S}{I} \right) \right]^{1/\alpha} \quad (3.98)$$

and

$$N_c = \frac{[7.50 \left( \frac{S}{I} \right)]^{2/\alpha}}{3}. \quad (3.99)$$

(v) Considering five tiers of interference with a total of 90 co-channel cells.

In this case,  $T = 5$  and  $(t, u) = (5, 0)$ ,  $(5, 1)$ ,  $(5, 2)$ ,  $(5, 3)$  and  $(5, 4)$ .

$$\frac{D}{R} = \left[ 7.57 \left( \frac{S}{I} \right) \right]^{1/\alpha} \quad (3.100)$$

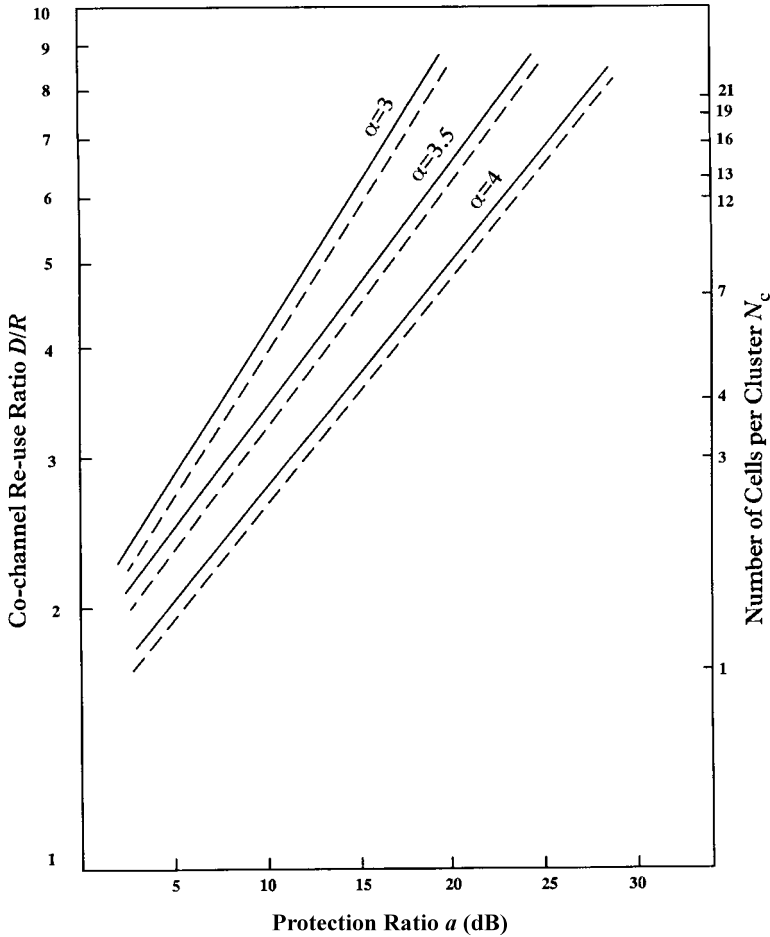

**Figure 3.14** Model III: Geographical Model with Several Tiers of Interferers. Protection Ratio Versus D/R and  $N_c$ .—, Five Tiers of Interference; - - -, One Tier of Interference

and

$$N_c = \frac{[7.54(\frac{S}{I})]^{2/\alpha}}{3}. \tag{3.101}$$

When considering more than five tiers of interference, no significant change in Equations (3.100) and (3.101) is achieved. In fact, the relation D/R versus the protection ratio in Figure 3.14 shows no significant difference between the case of one tier of interferers and the case

of five tiers of interferers. This is because, although higher order interference tiers contain more co-channel interfering cells, they are further away from the serving base station at multiples of  $D$  (see Figure 3.13). The interfering signal power received at the mobile station from any interfering cell is given by:

$$I_t \propto \left(\frac{1}{tD}\right)^\alpha \quad (3.102)$$

where  $t$  is the order of the interfering tier in which the interfering cell resides. Hence, the interfering signal power falls more rapidly with distance by a factor of  $t^\alpha$ , compared with the interfering signal power received from the first tier. To give an example, for  $\alpha = 4$ , the interfering signal power of a co-channel cell in the first tier is 625 times the interfering signal power of a co-channel cell in the fifth tier. That is to say:

$$\frac{I_1}{I_t} = t^\alpha \quad (3.103)$$

$$\frac{I_1}{I_5} = 5^4 = 625 (\approx 29\text{dB}). \quad (3.104)$$

Considering that there are 30 co-channel interfering cells in the fifth tier compared with only six co-channel interfering cells in the first tier, the total interference power contributed by the first tier is about 21 dB higher than the total interference power contributed by the fifth tier.

The relations  $D/R$  versus  $S/I$  in decibels, and  $N_c$  versus  $S/I$  ( $S/I$  is the protection ratio,  $a$ ) are illustrated in Figure 3.14, for different possible values of  $\alpha$ .

An alternative method to evaluate the interference from several tiers of co-channel cells is developed in Appendix A, leading to similar results to the above.

### 3.6.6 Model IV: Fading only Statistical Model

In this model, the received signals at the mobile station are assumed to have an amplitude which is varying with a Rayleigh distribution (see Figure 3.15(a)). The fading of the wanted and interfering signals are assumed to be uncorrelated and the shadowing effects on the signals are ignored. This model is based on one interferer, where the mobile

station is located between  $T_s$  and  $T_i$  at a distance  $xD$  from  $T_s$ , where  $0 < x < 1$ . Suppose that the signal amplitude received at the mobile station from the serving base station  $T_s$  is  $y_s$  and from the interfering base station  $T_i$  is  $y_i$ , then for satisfactory reception it is necessary that :

$$y_s \geq ry_i$$

where  $r$  is the 'amplitude' protection ratio. We need to calculate the probability of  $y_s$  being greater than  $y_i$  by the amount of the amplitude protection ratio,  $r$ . For a variable  $y$  which is Rayleigh distributed with

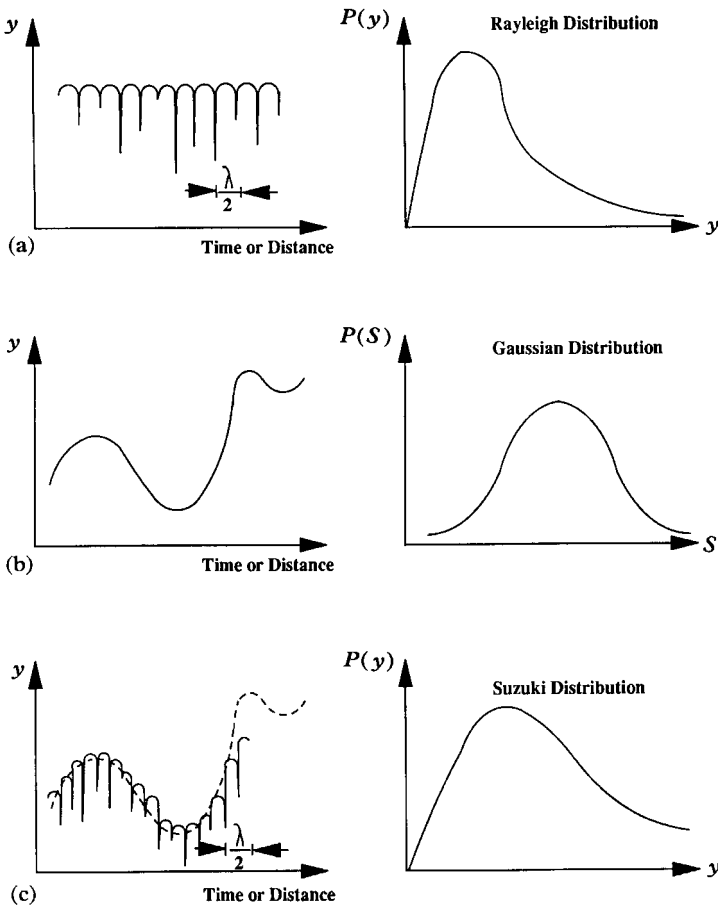

**Figure 3.15** (a) Model IV: Fading Only Statistical Model. (b) Model V: Shadowing Only Statistical Model. (c) Model VI: Fading and Shadowing Statistical Model

modal value  $\sigma$ , the probability density function (PDF) of the distribution is:

$$p(y) = \left(\frac{y}{\sigma^2}\right) \exp\left(\frac{-y^2}{2\sigma^2}\right). \quad (3.105)$$

The probability  $P_1$  that  $y_s \geq ry_i$  at a given  $y_i$  is:

$$P_1 = \int_{ry_i}^{\infty} p(y_s) dy_s = \exp\left(\frac{-r^2 y_i^2}{2\sigma_s^2}\right). \quad (3.106)$$

To obtain the probability  $P_2$  that  $y_s > ry_i$  for all  $y_i$  it is only necessary to integrate this function over all  $y_i$ , thus:

$$\begin{aligned} P_2 &= \int_0^{\infty} P_1 p(y_i) dy_i \\ &= \int_0^{\infty} \exp\left(\frac{-r^2 y_i^2}{2\sigma_s^2}\right) \left[\left(\frac{y_i}{\sigma_i^2}\right) \exp\left(\frac{-y_i^2}{2\sigma_i^2}\right)\right] dy_i \end{aligned} \quad (3.107)$$

$$= \int_0^{\infty} \left(\frac{y_i}{\sigma_i^2}\right) \exp\left\{\left(\frac{-y_i^2}{2}\right) \left[\left(\frac{r^2}{\sigma_s^2}\right) + \left(\frac{1}{\sigma_i^2}\right)\right]\right\} dy_i \quad (3.108)$$

$$\therefore P_2 = \frac{\sigma_s^2}{r^2 \sigma_i^2 + \sigma_s^2}. \quad (3.109)$$

The mean signal power is an inverse function of the distance between the transmitter and the receiver (the inverse  $\alpha^{\text{th}}$  power law). Hence, at the mobile station:

$$\frac{\sigma_s^2}{\sigma_i^2} = \frac{W_s [(1-x)D]^\alpha}{W_i (xD)^\alpha} \quad (3.110)$$

$$\therefore \frac{\sigma_s^2}{\sigma_i^2} = \frac{W_s (1-x)^\alpha}{W_i x^\alpha} \quad (3.111)$$

where  $W_s$  and  $W_i$  are the omnidirectionally radiated powers from  $T_s$  and  $T_i$  respectively.

Substituting Equation (3.111) in (3.109),  $P_2$  becomes:

$$P_2 = \frac{W_s (1-x)^\alpha}{r^2 W_i x^\alpha + W_s (1-x)^\alpha}. \quad (3.112)$$

$P_2$  is the probability that the wanted signal  $y_s$  is received at a level above the interfering signal  $y_i$  by the desired amplitude protection ratio  $r$ . This result was developed by Gosling [3.15, 3.22] for  $\alpha = 4$  and a similar result to Equation (3.109) was obtained in [3.21]. Following the assumption that the co-channel interference is independent of the actual amount of power transmitted by the base stations and that the size of all cells are roughly the same,  $W_s = W_i$ . Furthermore, considering the worst case of interference when the mobile station is nearest to the interfering base station  $T_i$  and furthest from its own serving base station  $T_s$ ,  $x_D = R$  and Equation (3.112) can be rewritten as follows:

$$\frac{D}{R} = \left[ \left( \frac{P_2}{1 - P_2} \right) \left( \frac{S}{I} \right) \right]^{1/\alpha} + 1 \quad (3.113)$$

and

$$N_c = \left\{ \left[ \left( \frac{P_2}{1 - P_2} \right) \left( \frac{S}{I} \right) \right]^{1/\alpha} + 1 \right\}^2 \quad (3.114)$$

where  $S/I$  is the 'power' protection ratio  $a$ , where  $a = r^2$ . Equations (3.113) and (3.114) are similar to Equations (3.78) and (3.79) obtained using the geographical model with one interferer, except for the protection ratio required by the fading only statistical model, which is scaled by a factor of  $P_2/(1 - P_2)$ . For 90% and 99% fading, the required protection ratio of a particular modulation technique using the fading only statistical model needs to be better by 9.5 dB and 20 dB respectively, compared with the geographical model with one interferer, to maintain the same spectral efficiency and voice quality. It can be shown that Equations (3.113) and (3.114) become identical to Equations (3.78) and (3.79) respectively for  $P_2 = 50\%$  (i.e. the two models coincide for  $P_2 = 50\%$ ).

The relations  $D/R$  versus  $S/I$  in decibels, and  $N_c$  versus  $S/I$  ( $S/I$  is the protection ratio,  $a$ ) are illustrated in Figure 3.16, for  $P_2 = 90\%$  and  $P_2 = 99\%$ ,  $\alpha = 4$ .

### 3.6.7 Model V: Shadowing only Statistical Model

In this model, the received signals (both wanted and interfering) at the mobile station are assumed to suffer shadowing effects as a result of

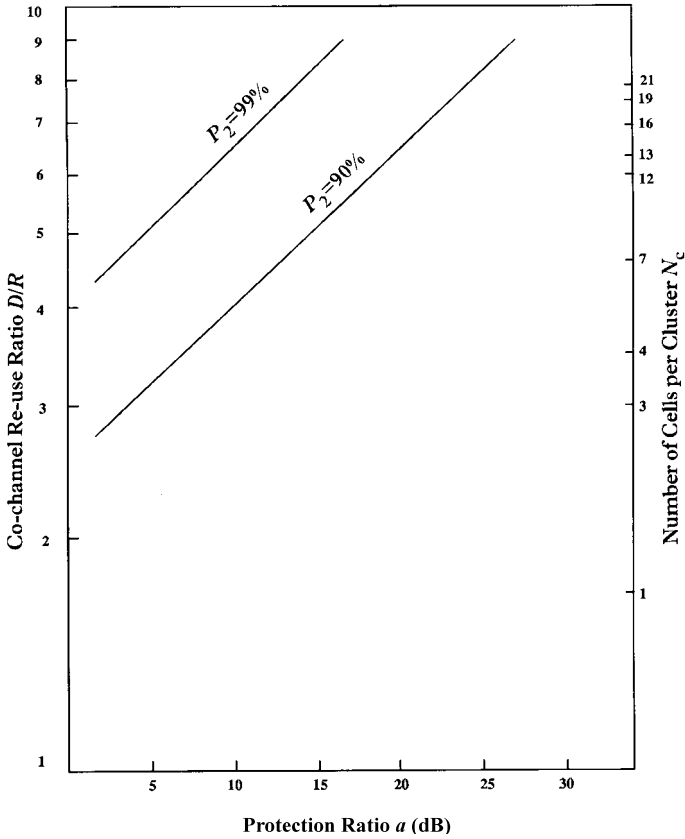
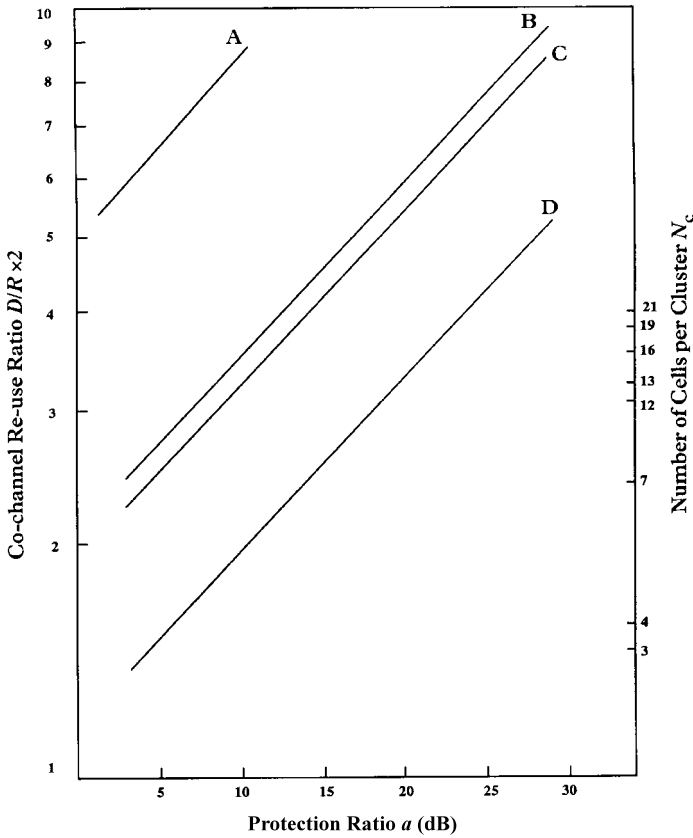

Figure 3.16 Model IV: Fading Only Statistical Model. Protection Ratio Versus  $D/R$  and  $N_c$ . One Interferer, Worst Case,  $\alpha = 4$

the signal being blocked by large structures such as hills and mountains (Figure 3.15(b)). The shadowing of the wanted and interfering signals are assumed to be uncorrelated and the fading effects on the signals are ignored. For shadowing, the variation in the received signal level measured in decibels is best described by a normal (Gaussian) distribution. The probability of  $10 \log (y_s^2)$  being greater than  $a_{dB} + 10 \log (y_i^2)$  is developed and numerically evaluated in [3.7], where  $a_{dB}$  is the protection ratio in decibels. The relations  $D/R$  versus  $S/I$  in decibels, and  $N_c$  versus  $S/I$  are graphically presented in Figure 3.17 for 90% and 99% shadowing with standard deviations  $\sigma = 6$  dB and 12 dB,  $\alpha = 4$ .

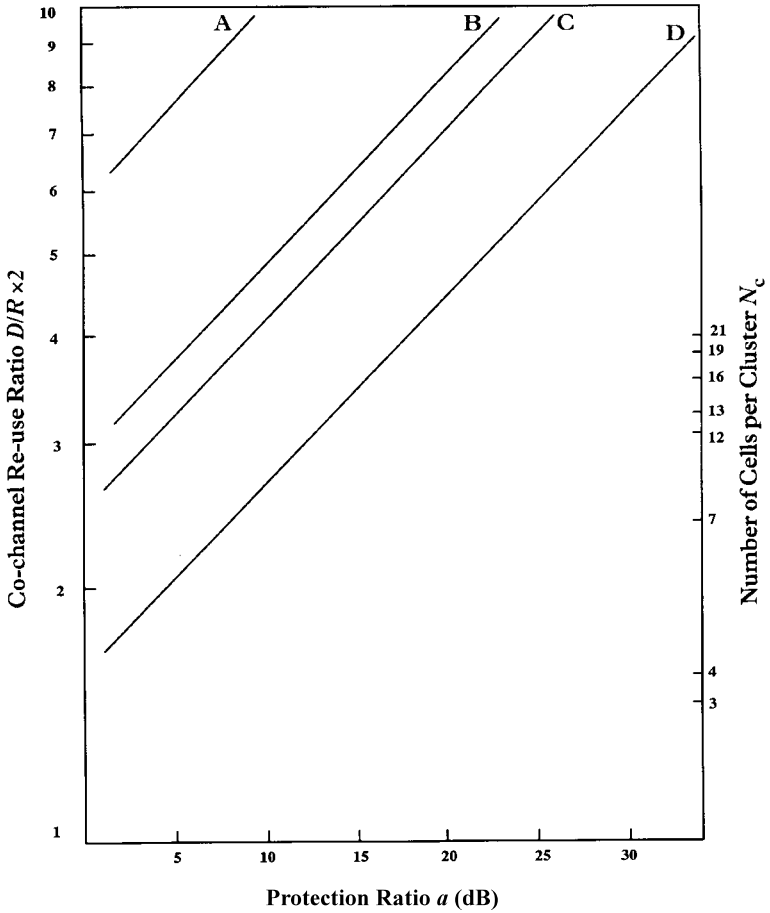

**Figure 3.17** Model V: Shadowing Only Statistical Model. Protection Ratio Versus  $D/R$  and  $N_c$ . One Interferer. Worst Case,  $\alpha = 4$ . A, 99% Shadowing,  $\sigma = 12$  dB; B, 90% Shadowing,  $\sigma = 12$  dB; C, 99% Shadowing,  $\sigma = 6$  dB; D, 90% Shadowing,  $\sigma = 6$  dB

### 3.6.8 Model VI: Fading and Shadowing Statistical Model

In land mobile radio, fading and shadowing of the received signal are not separated from each other. The fading and shadowing statistical model considers the general case when both the desired and interfering signals are undergoing fading and shadowing effects simultaneously, in an uncorrelated manner. In this case, the signal local mean varies log-normally with a superimposed fading which follows a Rayleigh distribution as shown in Figure 3.15(c). The superimposi-



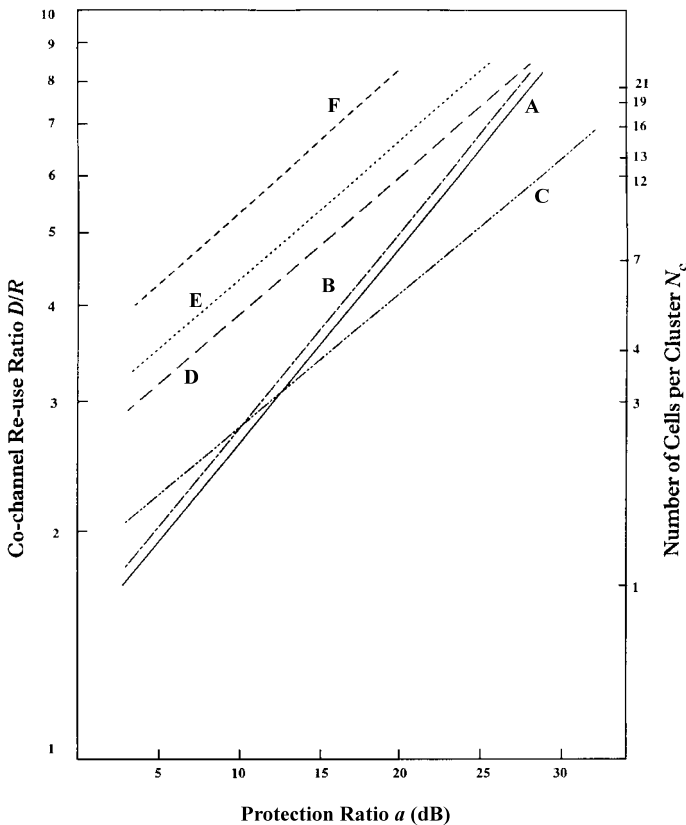

**Figure 3.18** Model VI: Fading and Shadowing Statistical Model. Protection Ratio Versus  $D/R$  and  $N_c$ . One Interferer, Worst Case,  $\alpha = 4$ . A, 99% Fading + 12 dB Shadowing; B, 99% Fading + 6 dB Shadowing; C, 90% Fading + 12 dB Shadowing; D, 90% Fading + 6 dB Shadowing

tion of the two types of variations (i.e. Rayleigh and log-normal) is sometimes referred to as the Suzuki distribution [3.20, 3.23]. Using this distribution, the probability of the wanted signal  $y_s$  being greater than the interfering signal  $y_i$  by the amount of the protection ratio is developed and evaluated in [3.7]. Based on a one-interferer situation, the relations  $D/R$  versus  $S/I$  in decibels, and  $N_c$  versus  $S/I$  are graphically presented in Figure 3.18 for 90% and 99% fading plus shadowing with standard deviations  $\sigma = 6$  dB and 12 dB,  $\alpha = 4$ .

### 3.7 COMPARISON OF THE VARIOUS MODELS

Figure 3.19 shows the re-use ratio  $D/R$  and the number of cells per cluster  $N_c$  as a function of the protection ratio, for the six different co-channel interference models developed earlier. Knowing the protection ratio of a modulation technique, the number of cells per cluster  $N_c$  required for a quality voice reception can be predicted using Figure 3.19. Hence the modulation spectral efficiency is evaluated using Equation (3.61). However, we need to compare the various co-



**Figure 3.19** Comparison of Various Co-channel Interference Models.  $\alpha = 4$ . —, (A) Geographical Model with Six Interferers; -.-.-, (B) Geographical Model with 90 Interferers; -.-.-.-, (C) Geographical Model with One Interferer; — — — —, (D) Fading (90%) Only Statistical Model; . . . . ., (E) Shadowing Only Statistical Model, 90% Shadowing,  $\sigma = 6$  dB; - - - - -, (F) Statistical Model, 90% Fading and 6 dB Shadowing

channel interference models in order that the best model can be used. Comparing these models, the following points can be concluded:

- (a) In general, the geographical models are easier to develop and use.
- (b) The geographical model with six interferers provides a good compromise between the two other geographical models. The geographical model with one interferer is not a realistic situation, whilst considering several tiers of interference achieves very little benefit as shown in Figure 3.19. The geographical model with six interferers is based on the assumption that all the interferers are active all the time which is a somewhat extreme case for the following reasons:
  - (i) not all the interferers are active all the time;
  - (ii) on average, for half the time the interferer is transmitting and for the other half it is receiving;
  - (iii) there is a time of silence between syllables, during which the interference can be reduced if quieting techniques, such as voice activated transmission, are employed in the mobile system.

Regarding the first objection, the assumption that all six co-channel interfering cells are active facilitates a busy hour situation. On the other hand, the model is designed based on the worst case to show the potential of a given modulation technique, although considering less than six interferers is mathematically trivial by manipulating the integer six in Equation (3.86). Furthermore, the practical considerations in (ii) and (iii) can be included in the conditions under which the protection ratio is subjectively assessed.

(c) Although fading and shadowing effects are not considered when the geographical models are developed, their effects on the signal can be included in the value of the protection ratio. This is achieved by performing subjective measurements to assess the value of the protection ratio for various modulation techniques under fading and shadowing conditions.

(d) Considering the statistical model category, the model with fading and shadowing accounts for the general situation which characterizes the mobile radio channel. The shadowing only statistical model is useful in urban areas with high rise buildings and in hilly

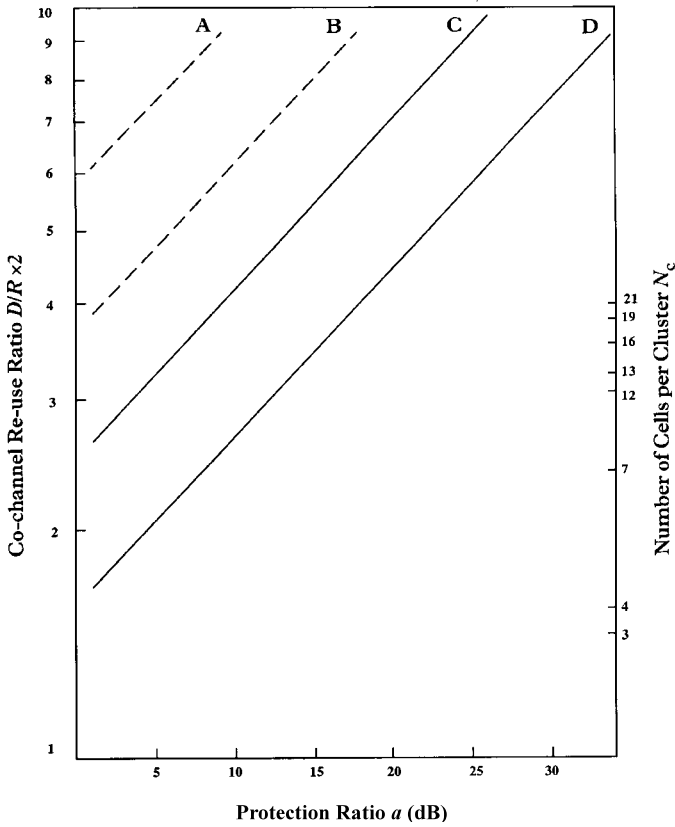

**Figure 3.20** Fading and Shadowing Statistical Models for One and Six Interferers. Protection Ratio Versus  $D/R$  and  $N_c, \alpha = 4$ . —, One Interferer; - - -, Six Interferers. A, 90% Fading + 12 dB Shadowing; B, 90% Fading + 6 dB Shadowing; C, 90% Fading + 12 dB Shadowing; D, 90% Fading + 6 dB Shadowing

areas. Also, mobile radio systems may adopt some means of diversity reception which will greatly reduce fading, in which case the shadowing only model is suitable. The fading only statistical model is suitable for suburban and low rise city locations. The fading only model is also useful when line of sight reception is available, which is a rare case in urban and suburban areas, especially with the low height antennas used in cellular systems.

(e) The major drawbacks in the statistical models are their complexity and in the unrealistic assumption of one interferer only. Attempts to account for all six interferers in the first tier of co-channel cells

[3.24] adds further complexity to the statistical models making them more difficult to apply.

(f) Furthermore, the way in which the statistical models are used by their advocates is ambiguous. If the protection ratio for a particular modulation system is to be subjectively assessed under fading and shadowing conditions and the statistical model with fading and shadowing is used, then large values of re-use distances appear to be necessary. For example, the protection ratio for 25/30 kHz FM cellular land mobile radio systems is in the range of 17–18 dB [3.6]; according to the statistical model with 90% fading and 6 dB shadowing the number of cells per cluster required for quality voice reception is 21, which does not comply with established cellular systems such as AMPS and TACS, which use only seven cells per cluster. Statistical models which account for all six closest interfering base stations [3.24] exhibit drastically higher predicted values of re-use distances  $D/R$  (and hence  $N_c$ ) as illustrated in Figure 3.20. On the other hand, the statistical models inherently assume that fading and shadowing cause identical deterioration to the signal regardless of the modulation technique employed. This may be true for shadowing since it is primarily a function of the topography near the mobile station, however, fading may have different effects on the signal according to the modulation technique employed. FM signal to noise performance, for instance, can be severely affected by fading near its threshold, unlike linear modulation techniques such as SSB with the signal to noise performance deteriorating more gradually with fading.

As a result, although the statistical models appear attractive to use, they do not represent the practical situation. I feel strongly in favour of the geographical model with six interferers. It is a useful tool in assessing the spectral efficiency of cellular systems, provided that the values of protection ratio used are subjectively evaluated for various modulation systems under fading and shadowing conditions.

### 3.7.1 Mathematical Justification of the Geographical Models

Analytical results for propagation over a 'plane earth' have been derived by Norton and simplified by Bullington [3.17]. For base station and mobile station antenna elevated heights  $h_B$  and  $h_M$ , respectively above ground level and separated a distance  $d$  apart, the

received power  $P_R$  is given in terms of the transmitted power  $P_T$  as follows:

$$P_R = P_T \frac{(h_B h_M)^2}{d^4} G_T G_R \quad (3.115)$$

where  $G_T$  and  $G_R$  are the gain of the transmitter antenna and receiver antenna respectively. Based on the above equation and considering the geographical model with one interferer, the desired signal power  $S$  received at the mobile station from its own serving base station is:

$$S = W_s \frac{(h_{B_s} h_M)^2}{R^4} G_{B_s} G_M \quad (3.116)$$

where  $W_s$  is the power transmitted by the serving base station,  $h_{B_s}$  is the serving base station antenna height,  $h_M$  is the mobile station antenna height,  $G_{B_s}$  is the serving base station antenna gain and  $G_M$  is the mobile station antenna gain.

Similarly, the interfering signal power  $I$  received at the mobile station from the interfering base station is:

$$I = W_i \frac{(h_{B_i} h_M)^2}{D^4} G_{B_i} G_M \quad (3.117)$$

where  $W_i$  is the power transmitted by the interfering base station,  $h_{B_i}$  is the interfering base station antenna height and  $G_{B_i}$  is the interfering base station antenna gain.

Hence, combining the results in Equations (3.116) and (3.117) yields:

$$\frac{S}{I} = \frac{W_s D^4 (h_{B_s})^2 G_{B_s}}{W_i R^4 (h_{B_i})^2 G_{B_i}} \quad (3.118)$$

A similar relation can be derived for the geographical model with six interferers.

From Equation (3.118), it can be seen that  $S/I$  can be maximized by maximizing  $W_s$ ,  $h_{B_s}$  and  $G_{B_s}$ . However, this is not feasible from the point of view of a mobile in the interfering co-cell, since that would lead to minimizing its  $S/I$ . As a result, it can be trivially shown that the optimum value for  $S/I$  within a cellular system is:

$$\left(\frac{S}{I}\right)_{\text{opt.}} = \left(\frac{D}{R}\right)^4 \quad (3.119)$$

which agrees with our results before based on the assumption of equal radiated power (i.e. equal cell sizes) and identical system parameters within the cellular system. Nevertheless, Equation (3.119) remains valid for mixed cell sizes when the cellular system is still growing. Equation (3.119) also represents the general case when  $W_s \neq W_i$ ,  $h_{Bs} \neq h_{Bi}$  and  $G_{Bs} \neq G_{Bi}$ .

### 3.8 SPECTRAL EFFICIENCY OF MODULATION TECHNIQUES BASED ON THE SIX-INTERFERER GEOGRAPHICAL MODEL

The efficiency of a modulation technique in a cellular system in terms of Channels/MHz/km<sup>2</sup> is given by Equation (3.61) as:

$$\eta_M = \frac{1}{B_c N_c A}.$$

The geographical model with six interferers establishes the relationship between the number of cells per cluster  $N_c$  and the protection ratio of the modulation technique employed. In theory,  $N_c$  can only take particular integer values (e.g.  $N_c = 1, 3, 4, 7, 9$ , etc.), which consequently suggests that  $N_c$  is a discontinuous function of the protection ratio. This restriction imposed on the values of  $N_c$  stems from the assumptions of a rigid hexagonal cell structure and each base station being located exactly at the centre of its cell. In practice, however, such a regular structure cannot be envisaged or imposed. Furthermore, because of environmental, legal and zoning restrictions as well as site availability problems it is not always possible to place the base station at its grid point. In fact, current designs of cellular systems permit a cell site to be positioned up to one-quarter of the nominal cell radius away from the ideal location [3.6]. For these reasons, no restrictions are imposed on the value of  $N_c$  and, hence, using the six-interferer geographical model, the spectral efficiency of a modulation technique in a cellular system is a function of the protection ratio. This is achieved by substituting for  $N_c$  from Equation (3.86), whence:

$$\eta_M = \frac{3}{B_c (6a)^{2/\alpha} A}. \quad (3.120)$$

Equation (3.120) shows that  $\eta_M$  is a function of four system parameters: the channel spacing  $B_c$ , protection ratio  $a$ , propagation

constant  $\alpha$  and the cell area  $A$ . The channel spacing and the protection ratio are directly related to the modulation technique, and since the protection ratio is representative of the voice quality, it needs to be subjectively assessed under realistic conditions. The propagation constant  $\alpha$  is dependent upon the nature of the terrain and urbanization

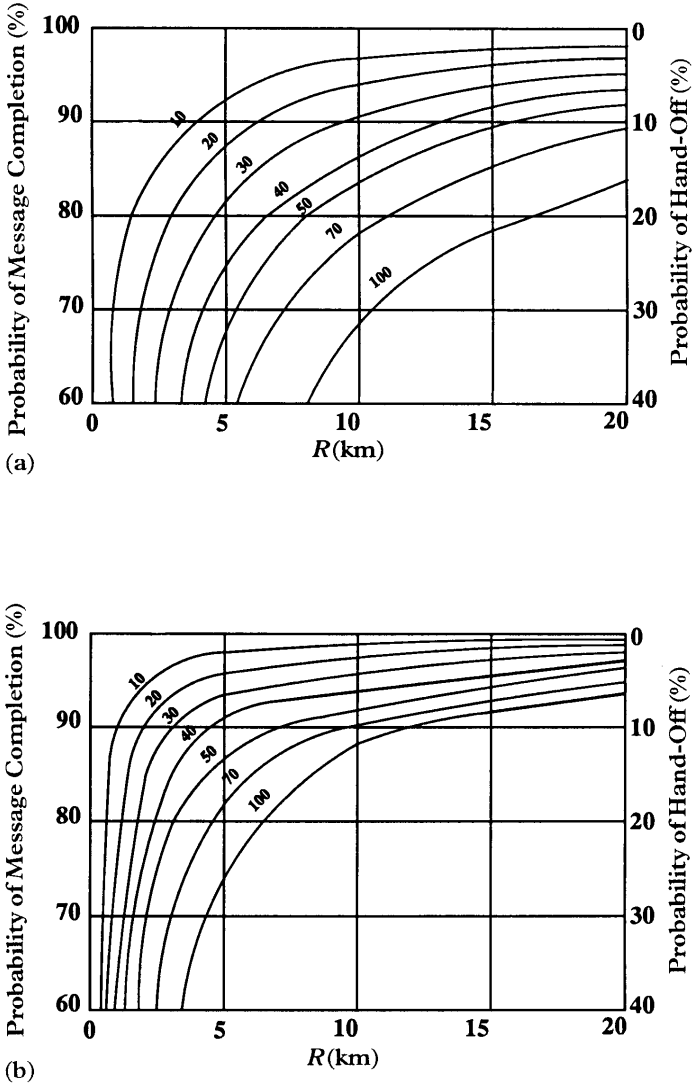

Figure 3.21 Probability of Message Completion. Mobile Speed in km/h is Indicated on the Curves. (a) Three-Minute Message. (b) One-Minute Message



degree and usually has values between three and four which can be verified by means of field measurements. The cell area is governed by several factors which are now discussed.

### 3.8.1 Factors Governing the Cell Area A

Equation (3.120) shows that the spectral efficiency of a modulation technique in a cellular system is inversely proportional to the cell area. Hence, the spectral efficiency can be maximized by minimizing the cell area. Theoretically, cellular systems can continue to grow indefinitely through the process of cell splitting. Nevertheless, there are several factors which will limit the minimum cell area which can be achieved in practice.

- (a) For small cells, the hand-off rate becomes unacceptably high. Figure 3.21 shows the probability of completion of messages of three minutes and one minute duration as a function of the cell radius [3.25]; the probability of hand-off is deduced.
- (b) Paging mobiles within the cellular system becomes more difficult to handle for smaller cells.
- (c) Co-channel interference becomes more difficult to manage for smaller cell sizes, especially considering the co-existence of other radio systems. In addition, errors in the location, hand-off and power control processes make reliable interference control more difficult as cells become smaller.
- (d) As cells become smaller and smaller, more control channels are required for the purpose of call set-up, monitoring, supervision, hand-off, etc. This in turn will reduce the spectral efficiency since more channels are dedicated for control functions rather than being used for voice communication.
- (e) Environmental, legal and zoning restrictions as well as site availability problems become more difficult as cells become smaller.

The above considerations are the dominant factors in restricting the minimum cell radius which can be employed in practice. Cells as small as 1.5 km in radius appear to be practical [3.25]. In our opinion, a cell radius as small as 1 km ( $A \approx 3 \text{ km}^2$ ) is possible with the present technologies. This value will be used in the efficiency comparisons of various cellular systems.

## REFERENCES

- [3.1] Brewster, R. L., 1986 Telecommunication Technology, Ellis Horwood Series in Electronics and Communication Engineering John Wiley and Sons, Chichester
- [3.2] Shanmugam, K. S., 1979 Digital and Analog Communication Systems John Wiley and Sons, New York
- [3.3] Schwartz, M., 1970 Information Transmission, Modulation, and Noise, Second Edition, McGraw-Hill Kogakusha, Tokyo
- [3.4] Stremmer, F. G., 1982 Introduction to Communication Systems, Addison-Wesley Series in Electrical Engineering Second Edition Publishing Company, Reading, MA
- [3.5] Lee, W. C. Y., 1986 Elements of Cellular Mobile Radio Systems, IEEE Trans. Veh. Technol. **VT-35** (2) May pp. 48–56
- [3.6] MacDonald, V. H., 1979 Advanced Mobile Phone Services: The cellular Concept Bell Sys. Tech. J. **58** (1) January pp. 15–43
- [3.7] French, R. C., 1979 The Effect of Fading and Shadowing on Channel Re-use in Mobile Radio IEEE Trans. Veh. Technol. **VT-28**, (3) August pp. 171–81
- [3.8] CCIR, 1986 Report 358–5, XVI Plenary Assembly, Dubrovnik, Vol. VIII-1, International Telecommunication Union pp. 3–13
- [3.9] Bullington, K., 1984 Radio Propagation for Vehicular Communication Land Mobile Communication Engineering IEEE Press, New York (Reprinted from: 1977 IEEE Trans. Veh. Technol. **VT-26**, November pp. 295–308)
- [3.10] Okumura, Y., et al., Field Strength and its Variability in VHF and UHF Land-Mobile Radio Service Land Mobile Communication Engineering IEEE Press, New York . (Reprinted with permission from: 1968 Rev. Elec. Commun. Lab., **16**, September–October pp. 825–73).
- [3.11] Young, W. R., Jr, 1986 Comparison of Mobile-Radio Transmission at 150, 450, 900 and 3700 Mc Land Mobile Communication Engineering IEEE Press, New York (Reprinted from: 1952 Bell Syst. Tech. J. **31**, November pp. 1068–85)
- [3.12] Black, D. M., 1984 Some Characteristics of Mobile-Radio Propagation at 836 MHz in the Philadelphia Area Land Mobile Communication Engineering, IEEE Press, New York (Reprinted from: 1972 IEEE Trans. Veh. Technol **VT-21**, May pp. 45–51)
- [3.13] IEEE Vehicular Technology Society Committee on Radio Propagation. Coverage Prediction for Mobile Radio Systems Operating in the 800/900 MHz Frequency Range. 1988 IEEE Trans. on Veh. Technol. Special Issue on Mobile Radio Propagation **VT-37**, (1) February
- [3.14] Hata, M., Kinoshita, K. and Hirade, K., 1984 Radio Link Design of Cellular Land Mobile Communication Systems Land Mobile Communication Engineering IEEE Press, New York (Reprinted from: 1982 IEEE Trans. Veh. Technol. **VT-31**, February pp. 25–31)

- [3.15] Gosling, W., 1978 A Simple Mathematical Model of Co-channel and Adjacent Channel Interference in Land Mobile Radio Radio and Electron. Eng. **48** (12) December pp. 619–22
- [3.16] Lee, W. C. Y., 1982 Mobile Communications Engineering, McGraw-Hill, New York
- [3.17] Reudink, D. O., 1984 Properties of Mobile Radio Propagation Above 400 MHz, Land Mobile Communication Engineering IEEE Press, New York (Reprinted from: 1974 IEEE Trans. Veh. Technol. **VT-23**, November pp. 143–59)
- [3.18] Nylund, H. W., 1984 Characteristics of Small Area Signal Fading on Mobile Circuits in the 150 MHz Band Land Mobile Communication Engineering IEEE Press, New York (Reprinted from: 1968 IEEE Trans. Veh. Technol. **VT-17**, October pp. 24–30)
- [3.19] Arredondo, G. A., Feggeler, J. C. and Smith, J. I., 1979 Advanced Mobile Services: Voice and Data Transmission Bell Sys. Tech. J. **58** (1) January pp. 97–122
- [3.20] Parsons, J. D., 1984 Propagation and Interference in Cellular Radio Systems IEE Conference Publication Number 238, May 1984, pp. 71–5
- [3.21] Daikoku, K. and Ohdate, H., 1983 Optimal Channel Re-use in Cellular Land Mobile Radio Systems IEEE Trans. Veh. Technol., **VT-32** (3) August pp. 217–24
- [3.22] Gosling, W., 1980 Protection Ratio and Economy of Spectrum Use in Land Mobile Radio IEE Proc. **127** Pt F (3) June pp. 174–78
- [3.23] Parsons, J. D. and Ibrahim, M. F., 1983 Signal Strength Prediction in Built-up Areas; Part 2: Signal Variability IEE proc. **130**, Pt F (5) August pp. 385–91
- [3.24] Muammar, R. and Gupta, S. C., 1982 Co-channel Interference in High Capacity Mobile Radio Systems IEEE Trans. Commun. **COM-30** (8) August pp. 1973–78
- [3.25] CCIR, 1982 Report 740–1, XV Plenary Assembly, Geneva Vol. VIII, International Telecommunication Union

# 4

## ***Spectral Efficiency of Digital Modulation Techniques***

### **4.1 INTRODUCTION**

Analogue modulation systems are well established for the transmission of voice in today's cellular systems. Digital modulation systems, however, are becoming increasingly popular for a variety of reasons. First of all, digital modulation systems offer a very wide range of possibilities, which in turn provide a great deal of flexibility. Digital techniques incorporate enhanced capabilities more easily and allow the integration of the components using VLSI (very large scale integration) techniques, which result in smaller and, hopefully, cheaper equipment. Also, digital cellular systems can easily be made compatible with the Integrated System Digital Network (ISDN) which can support data as well as voice transmission. Furthermore, the use of digital systems enables security through encryption to be easily achieved – an important requirement in today's world radio environment. For such reasons, it is not so surprising that all nine systems which were proposed for the Pan-European cellular mobile radio system in the mid-eighties were digital [4.1] and that North America and Japan were well advanced in their plans to implement digital cellular systems. On the other hand, digital transmission is normally greedy in its use of bandwidth [4.2] and since spectral efficiency is of prime importance in the land mobile radio environment, the current trend to assume that 'digital is good and analogue is bad/old fashioned' may not be justifiable.

In the previous chapter, the spectral efficiency of analogue modulation techniques within cellular land mobile radio system was evaluated. Although the method was mainly designed for analogue

modulation techniques, it can be easily applied to digital modulation techniques. This is mainly because the interference models used are independent of the modulation technique employed. Also, because of the nature of digital systems and the way some parameters are defined, voice channel spacing and the protection ratio need to be evaluated so they can be used with the modulation efficiency equation developed in Chapter 3. The channel spacing is usually defined in terms of kbps and we need to evaluate that in kHz. Also, there is a possibility of an objective assessment of the protection ratio using the bit error rate (BER) as a quality measure.

In this chapter, two approaches to evaluate the channel spacing and the protection ratio are presented. Consequently, a brief review of digital modulation techniques is given and the key parameters required for the evaluation are highlighted. The channel spacings of digital modulation techniques are very much dependent on the voice coding method used. It is necessary, therefore, to present a short survey of the voice coding techniques available today. The channel spacing of a digital modulation technique is then evaluated using a theoretical as well as a practical method. The two approaches are compared. It must be noted here that the objective of the exercise is not to evaluate the channel spacing and the protection ratio for all digital modulation techniques, but rather to show a systematic method to evaluate them given the necessary parameters. The results are then used in the modulation efficiency formula, developed in the previous chapter. The spectral efficiency assessment of various analogue and digital cellular land mobile radio systems is the subject of Chapter 6.

## 4.2 BASIC DIGITAL MODULATION TECHNIQUES

In digital modulation techniques, to convey information, a parameter of a continuous high-frequency carrier is varied in proportion to a low-frequency baseband digital message signal. The carrier to be modulated has the following general form:

$$x_c(t) = v(t) \cos [w_c t + \phi(t)] \quad w_c = 2\pi f_c \quad (4.1)$$

where  $v(t)$  is the instantaneous amplitude of the carrier,  $f_c$  is the carrier frequency and  $\phi(t)$  is the instantaneous phase deviation of the carrier.

In general, there are three basic digital modulation techniques: amplitude modulation (AM), frequency modulation (FM) and phase

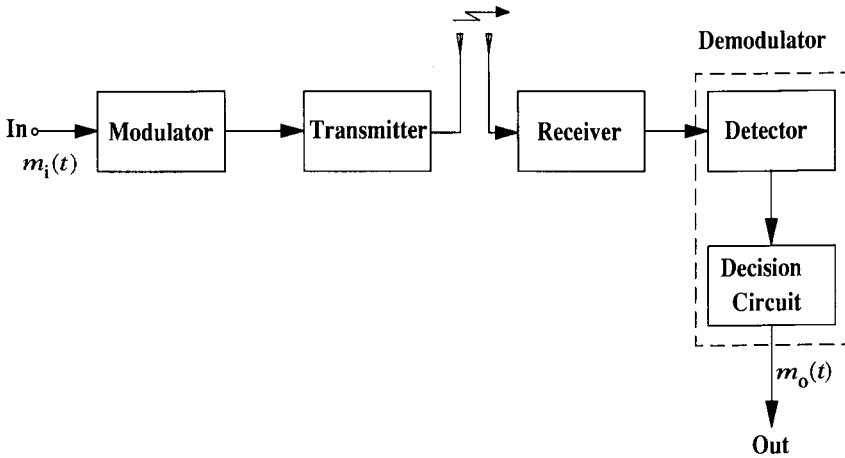

**Figure 4.1** Primary Components of a Digital Radio Communication System

modulation (PM). In amplitude modulation,  $v(t)$  is linearly related to the digital message signal  $m(t)$ , in which case it is a linear process. However, if  $\phi(t)$  or its time derivative is linearly related to  $m(t)$ , then we have PM or FM respectively; these are non-linear processes. On the other hand, each of the basic digital modulation techniques has a large number of variants. Hybrid digital techniques are also possible and have received increased attention in the recent years because of their inherent economical use of spectrum [4.3].

A simple radio frequency digital communication system is shown in Figure 4.1. The baseband digital message may be filtered, shaped, etc. prior to modulating the carrier so that desirable results are achieved. At the receiver, the baseband digital message is recovered using a detection process. Basically, there are two types of detection: coherent detection and non-coherent detection. In coherent detection, there is a requirement for a sinusoidal carrier which is perfectly matched to both the frequency and phase of the received carrier. Such a phase reference may be obtained either from a transmitted pilot tone or from the modulated signal itself. Non-coherent detection, however, is based upon waveform characteristics independent of phase, such as amplitude or frequency, and hence does not require a phase reference. Detection is usually followed by a decision process which converts the recovered baseband digital message signal into a sequence of digital bits. The decision process requires bit synchronization which can be extracted from the received waveform.

### 4.2.1 Digital Amplitude Modulation (AM) Techniques

The simplest digital amplitude modulation technique can be mathematically represented as follows:

$$x(t) = \frac{1}{2}[1 + m(t)] \cos(w_c t) \quad (4.2)$$

where  $m(t)$  is a binary digital message signal. For the case of  $m(t) = \pm 1$ , then we have amplitude shift keying (ASK) or on-off keying (OOK) modulation, this is depicted in Figure 4.2(b). ASK waveform can be detected either coherently or non-coherently. However, there is a slight difference in performance, compared to the increase in complexity needed to maintain phase coherence between the transmitted signal and the local carrier.

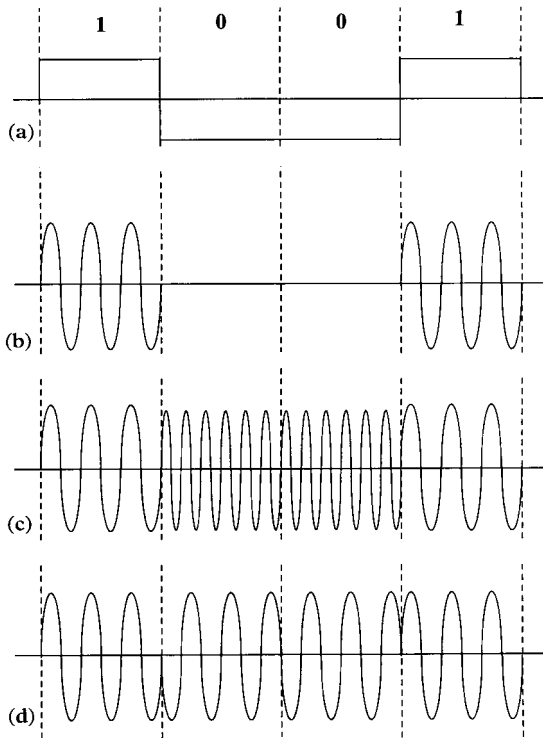

**Figure 4.2** Basic Digital Modulation Techniques. (a) Binary Modulating Signal. (b) ASK Signal. (c) FSK Signal. (d) PSK Signal

The carrier in Equation (4.2) conveys no information, and hence power efficiency can be improved by the use of a double-sideband suppressed carrier (DSB-SC), which has the following general form:

$$x(t) = m(t) \cos(\omega_c t) \quad m(t) = 0 \text{ or } 1. \quad (4.3)$$

Spectral efficiency can be improved by a factor of two by the use of single-sideband (SSB) digital modulation with non-trivial practical implementation and a considerable increase in complexity.

Another variation of AM is quadrature amplitude modulation (QAM), which is obtained by summing two DSB-SC signals at  $90^\circ$  apart in phase. A quadrature amplitude modulated signal has the following general form:

$$x(t) = m_I(t) \cos(\omega_c t) + m_Q(t) \sin(\omega_c t) \quad (4.4)$$

where  $m_I(t)$  and  $m_Q(t)$  are independent binary data signals, in which case QAM is as efficient in both required power and bandwidth as an ideal SSB. Quadrature partial response (QPR) is obtained if  $m_I(t)$  and  $m_Q(t)$  are three-level duobinary signals (+1, -1 or 0) coded to affect minimum intersymbol interference. Coherent detection is required for QAM and QPR and hence any phase errors that occur result in interference between the I and Q channels which in turn will degrade their performance.

#### 4.2.2 Digital Frequency Modulation (FM) Techniques

Frequency shift keying (FSK) is the simplest form of a digital FM technique. FSK is generated by switching the frequency of the carrier between two values ( $f_1$  and  $f_2$ ), corresponding to a binary message signal;  $f_1 - f_2$  being small compared with the carrier frequency  $f_c$  (see Figure 4.2(c)). It is a common practice in FSK modulation schemes to specify the frequency spacing in terms of the modulation index,  $h$ , which is defined as:

$$\begin{aligned} h &= (f_1 - f_2)T_b \\ h &= \Delta f T_b \end{aligned} \quad (4.5)$$

where  $T_b$  is the symbol duration.

FSK can be detected either coherently or non-coherently. Non-coherent detection of FSK can be achieved using two bandpass filters, followed by envelope detectors and a decision circuit. It is also



possible to detect FSK signals non-coherently, using a discriminator followed by amplitude detection.

Other modified forms of FSK technique are also used. For example, continuous phase FSK (CP-FSK) is used to avoid the abrupt phase changes at bit transition instants and hence leading to improved spectral efficiency. Optimal coherent detection of CP-FSK is achieved with values of  $h$  in the vicinity of 0.7. Minimum shift keying (MSK) is a special case of CP-FSK for which coherent detection with  $h = 0.5$  is used. Other forms of CP-FSK can be found in the literature [4.4].

### 4.2.3 Digital Phase Modulation (PM) Techniques

A well known basic type of phase modulation is binary phase shift keying (BPSK), in which the carrier phase is shifted between two values,  $0^\circ$  and  $180^\circ$ , as shown in Figure 4.2(d). BPSK modulation requires coherent detection, in which case a precise phase reference in the receiver is necessary. Differentially encoded PSK (DE-PSK) and differential PSK (DPSK) are other modified versions of PSK. With DE-PSK, the binary digital message is conveyed via transitions in the carrier phase. That is to say, no transition in phase corresponds to, say, binary '0' and a  $180^\circ$  transition corresponds to binary '1'. With DPSK, the information is also differentially encoded, but a detector is employed which uses the signal from the previous bit interval as a phase reference for the current bit interval. The performance of both DE-PSK and DPSK is somewhat inferior to that of coherent PSK.

### 4.2.4 M-Ary Digital Modulation Schemes

$M$ -ary digital modulation schemes are just an extension to the basic digital modulation techniques discussed earlier. In  $M$ -ary schemes, one of  $M$  signals is transmitted during each signalling interval, where  $M$  is greater than 2. Thus, we can have  $M$ -ary ASK such as 4-ASK and 16-QAM. QPSK, 8-PSK and 16-PSK are examples of  $M$ -ary PSK. With  $M$ -ary FSK, one of a set of  $M$  possible carriers (or carrier frequencies) is selected according to the modulating digital message. Figure 4.3 shows constellation diagrams for some  $M$ -ary digital modulation schemes.

$M$ -ary digital modulation schemes are often used whenever bandwidth needs to be conserved at the expense of power or vice versa; an advantage which cannot be achieved with binary modulation techniques.  $M$ -ary PSK schemes are used to conserve bandwidth at the expense of increased power requirements, while wideband  $M$ -ary

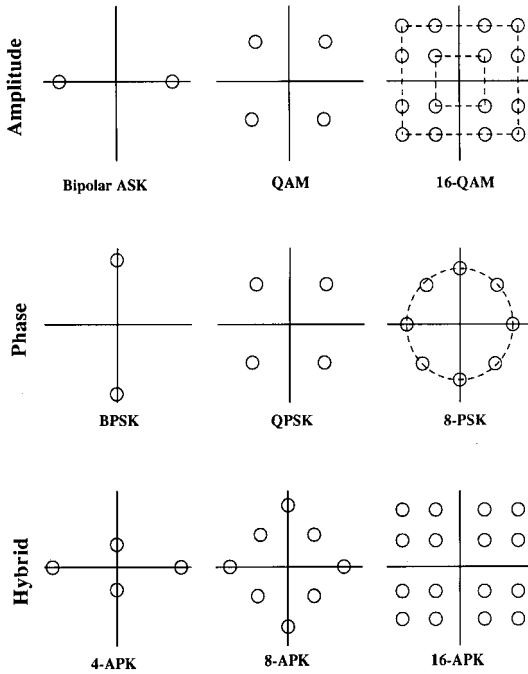

Figure 4.3 Constellation Diagrams for some  $M$ -ary Digital Modulation Schemes

FSK schemes utilize more bandwidth to provide increased immunity to noise and conserve power.

### 4.2.5 Hybrid Digital Modulation Schemes

By combining two different digital modulation techniques, it is possible to arrive at a hybrid scheme which out performs either technique alone. The most commonly used hybrid technique is amplitude and phase shift keying (APK). The main advantage of the APK scheme is its superior bandwidth efficiency. An  $M$ -ary form of APK is usually used for this reason and one example is 16-APK.

### 4.2.6 Performance Comparison of Various Digital Modulation Techniques

The performance of digital modulation techniques can be compared in a number of ways. However, we shall limit the comparison to those

**Table 4.1** Performance of Representative Set of Digital Modulation Techniques

Digital Modulation and Detection		Speed (bps/Hz)		$E_b/N_o(dB)$	
		Theoretical	Practical	Ideal BER = $10^{-4}$	Fading BER = $10^{-2}$
AM	ASK-Envelope	1	< 0.8	11.9	19
	ASK-C	1	0.8	11.4	17
	QAM	2	1.7	8.4	14
	QPR	2.5	2.25	10.7	16.5
	16-QAM	4	3.0	14.4	21.5
FM	FAK ( $h = 1$ ) – NC	1	0.8	12.5	20
	CP-FSK ( $h = 0.7$ ) – NC	1	1.0	9.2	18
	CP-FSK ( $h = 0.7$ ) – C	1	1.0	7.4	13
	MSK ( $h = 0.5$ ) – C	2	1.9	8.4	14
	MSK ( $h = 0.5$ ) – DE	2	1.9	9.4	17
PM	BPSK-C	1	0.8	8.4	14
	DE-BPSK	1	0.8	8.9	17
	DPSK	1	0.8	9.3	17
	DQPSK	2	1.8	10.7	20
	QPSK	2	1.9	8.4	13.5
	8-PSK	3	2.6	11.8	16.5
	16-PSK	4	2.9	16.2	21
AM/PM	4-APK	2	< 2	8.4	13.5
	8-APK	3	2.8	9.4	15
	16-APK	4	3.3	12.4	18

C, Coherent; NC, Non-coherent; DE, Differential Encoding. Data taken from a variety of sources QAM/APK belong to the same family and should in theory have the same performance.

parameters which are particularly relevant to the assessment of spectral efficiency of various digital modulation techniques as applied to cellular systems. The most important parameters governing the spectral efficiency of a digital modulation technique are the bandwidth efficiency and the signal to noise performance required to achieve a given bit error rate (BER).

The bandwidth efficiency of a digital modulation technique can be conveniently characterized in terms of the transmitted bits per second per Hertz (bps/Hz). This is also referred to as the ‘speed’ of a modulation technique and is now a standard term used in CCIR recommendations and regulations. In practice, implementation limitations reduce the theoretical speed of various digital modulation techniques. Table 4.1 shows some tabulated values of the theoretical and practical speed of various modulation techniques taken from a number of sources [4.3, 4.5, 4.6].

It is also important to compare different digital modulation techniques in terms of the signal to noise ratio (SNR) required to achieve a

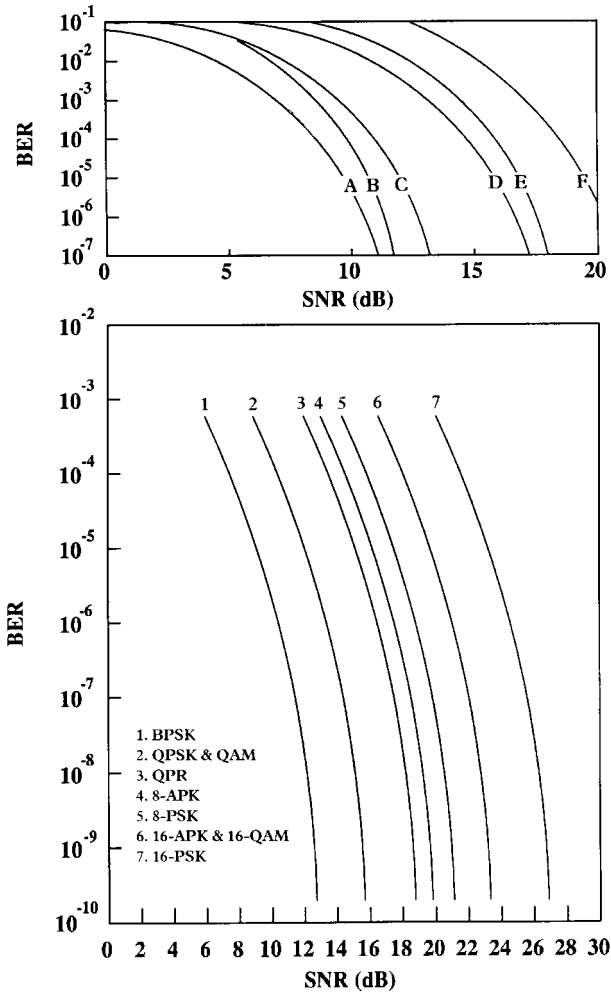

**Figure 4.4** BER Versus SNR for Some Digital Modulation Techniques. A, Coherent PSK; B, DPSK; C, Coherent FSK; D, Coherent ASK; E, Non-coherent FSK; F, Non-coherent ASK

specific BER. The ideal BER performance of digital modulation techniques as a function of SNR in the presence of additive white Gaussian noise (AWGN) has been derived and well documented in many sources (see for example [4.7]). The BER versus SNR for some digital modulation techniques is plotted in Figure 4.4. Often, the BER performance is measured in terms of the average signal energy per bit to

noise power spectral density ( $E_b/N_o$ ), where  $E_b/N_o = \text{SNR/bit}$  [4.7]. The normalized SNR or  $E_b/N_o$  is used because it allows the performance of different digital modulation systems operating at different bandwidths to be compared directly. Table 4.1 shows the  $E_b/N_o$  required for a BER of  $10^{-4}$  for various digital modulation techniques.

For a more realistic comparison of digital modulation techniques, their behaviour in a land mobile radio environment needs to be considered. The effects of fading and delay spread on various digital modulation techniques are of particular interest. The effect of fading is to introduce amplitude and phase variations into the transmitted

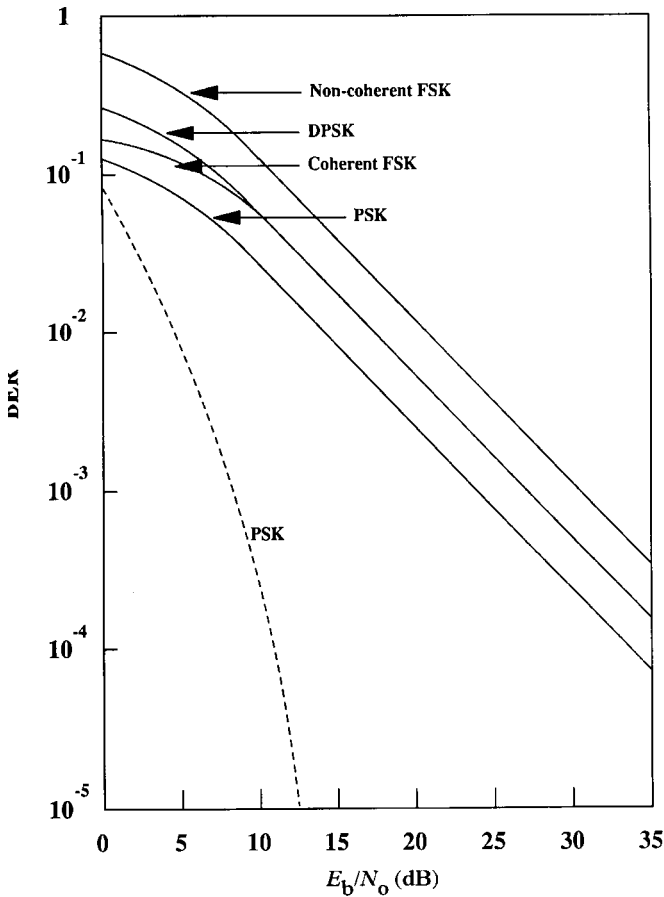

Figure 4.5 Performance of Some Digital Modulation Techniques in a Rayleigh Fading Channel.—, Fading; - - -, Non-fading.

signal. These variations can cause bit error bursts of various lengths, which worsen the BER performance compared with the ideal AWGN channel. The effect of Rayleigh fading on various digital modulation techniques has been studied (e.g. [4.7, 4.8]) and an example of BER versus  $E_b/N_0$  is shown in Figure 4.5. Table 4.1 shows the  $E_b/N_0$  value needed to achieve a BER of  $10^{-2}$  in a Rayleigh fading channel.

There are several techniques which can be used to mitigate the effect of fading, and hence reduce the BER, such as diversity reception [4.7] and error correction coding. Moreover, constant envelope digital modulation techniques such as PSK and FSK are more resilient to amplitude fading than ASK, however, coherent detection can prove quite difficult to implement due to fast phase variations.

Delay spread is also a result of multipath characteristics of the mobile radio channel. The effect of delay spread is to smear each pulse in the time domain, causing intersymbol interference. Values of delay spread range from  $0.2 \mu\text{s}$  for open areas to  $0.5 \mu\text{s}$  for suburban areas and  $3 \mu\text{s}$  for urban areas. The main impact of the delay spread phenomenon on digital systems is actually to give rise to an upper limit to the maximum transmission rate that may be achieved [4.9, 4.10]. This limit may be improved by employing techniques such as diversity reception and equalization.

In summary, the most promising digital modulation techniques for cellular systems are those which give rise to a high bandwidth utilization in terms of bps/Hz and have good BER performance with low  $E_b/N_0$ , particularly in a fading environment. As a preliminary opinion, QPSK (4-APK and QAM) is a good candidate for spectrally efficient cellular systems, followed by continuous phase FSK such as MSK. Higher levels of PSK and APK (i.e. 8-PSK and 8-APK, etc.) will entail a large power penalty. Using such digital modulation techniques may not be a good idea since cellular systems are also power limited, mainly due to co-channel interference. High power transmission will require the use of larger cells in order to control co-channel interference, which will reduce the overall spectral efficiency of the system. The trade off between bandwidth utilization and the protection ratio is discussed in more detail in Chapter 6.

### 4.3 VOICE CODING (SPEECH DIGITIZATION)

Speech or voice signals are analogue in nature. Consequently, in order to transmit speech using digital modulation techniques, it is necessary to convert analogue speech into a digital form. This is known as

analogue to digital (A/D) conversion, which basically consists of the three following processes.

- (a) *Sampling*: which converts a continuous time signal to a discrete time signal.
- (b) *Quantizing*: which converts a continuous amplitude sample into a discrete amplitude sample.
- (c) *Coding*: each quantized sample level can be represented by a code. One possibility is to use a binary code which can be then transmitted using any digital modulation technique.

Figure 4.6 is a block diagram of a digital communication system showing the above three processes at the transmit side and their complementary processes used to recover the analogue signal at the receive side. Note that channel coding can be combined with the speech coder.

Analogue to digital conversion is always necessary whenever an analogue signal needs to be conveyed within a digital system. Cellular systems are mainly used for voice transmission, hence, the way in which voice is coded can influence the spectral efficiency as well as the quality of digital cellular systems. In this sense, the

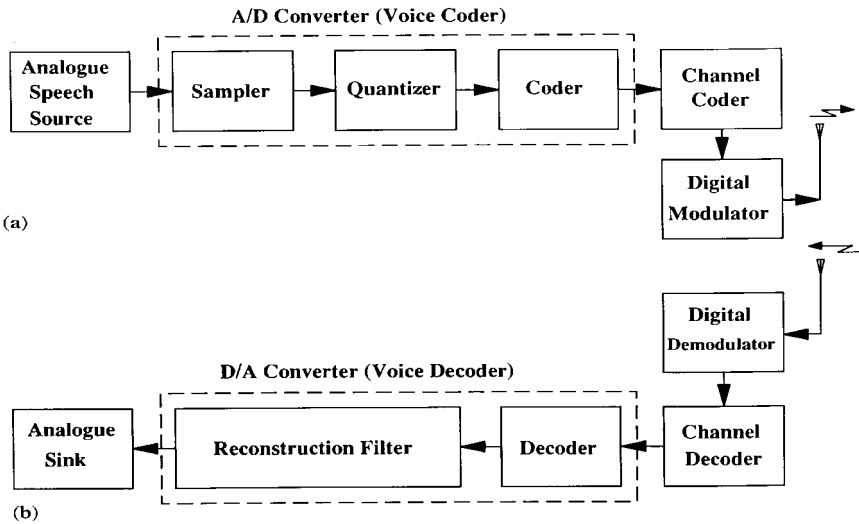

**Figure 4.6** Digital Communication of Analogue Speech. (a) Transmit Side. (b) Receive Side

study of voice coding is part and parcel of digital modulation techniques if their spectral efficiency within cellular systems is to be assessed.

### 4.3.1 Basic Types of Voice Coders

In principle, there are three classes of voice coders – waveform coders [4.11], Source Coders [4.12, 4.13] and hybrid waveform coders/vocoders, [4.13].

#### *Waveform coders*

This is a broad class of voice coders based on, as the name indicates, waveform techniques. Waveform voice coders strive for facsimile reproduction of the voice signal waveform. They are designed to be signal independent and hence they tend to be robust for a wide range of talker characteristics and noise environments. Depending on the technique employed, waveform coders can be subdivided into time domain and frequency domain coders. Examples of time domain coding include: pulse code modulation (PCM), differential PCM (DPCM), adaptive DPCM (ADPCM), delta modulation (DM), and adaptive DM (ADM). An example of frequency domain waveform coders is a category known as sub-band coders. The specific descriptions of various waveform coders are immaterial to our study but the interested reader is referred to [4.11]. Waveform coders are generally characterized by a relatively high transmission bit rate and good voice quality.

#### *Source coders*

A second class of voice coders utilizes a signal analysis procedure for extracting perceptually significant parameters from the input voice signal. Such parameters are then used to synthesize an output which is useful to the human ear. Source coders for speech are generically referred to as 'vocoders'. Specific descriptions of various types of vocoders can be found in [4.12]. Vocoders are generally characterized by a relatively low transmission bit rate and a synthetic voice quality. In particular, talker recognition is substantially degraded and coder performance is talker dependent.



*Hybrid waveform coders/vocoders*

This intermediate class is designed to fill the gap between the above extreme classes of voice coders in terms of bit rate and quality. The hybrids aim to combine some advantages of both waveform and source coders such that a moderate bit rate can be achieved with a more natural speech quality. This class of coders is currently being investigated, developed and further improved, particularly for mobile radio applications.

**4.3.2 General Comparison of Various Voice Coders**

Voice coders are compared in terms of their bandwidth efficiency and quality. Bandwidth efficiency can be measured in terms of the transmission bit rate of coded speech, which may also include error protection/correction coding to overcome the channel impairments. Objective quality measures in term of the SNR and BER can be used, but best of all are the subjective quality measures. In cellular systems, complexity considerations are inferior to the efficiency and quality of voice coders.

Figure 4.7 shows a spectrum of voice coding transmission bit rates [4.13]. It is obvious that source coding techniques can achieve much lower bit rates than waveform coding techniques. Nevertheless, source coding entails fundamental limitations on subjective quality and great expenses in terms of complexity and cost. This can be seen

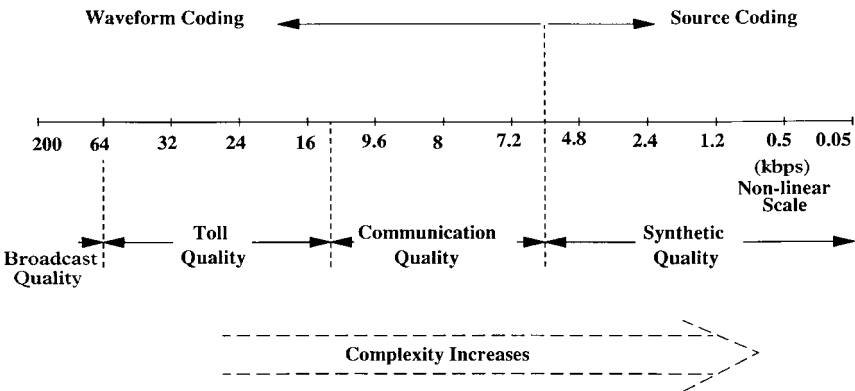

**Figure 4.7** Spectrum of Speech Coding Transmission Rates with Associated Quality and Complexity

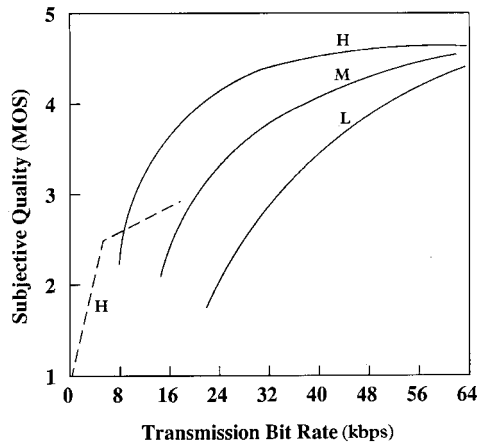

**Figure 4.8** Subjective Quality Versus Bit Rate for Various Speech Coders.—, Waveform Coder;— —, Source Coder. H, High Complexity; M, Medium Complexity; L, Low Complexity

more clearly in Figure 4.8 which shows the subjective quality in terms of mean opinion score (MOS) versus the bit rate for various speech coders [4.11]. Hence, because of the synthetic voice quality they offer, vocoders are not adequate for cellular systems despite their economical use of spectrum.

### 4.3.3 A Voice Coder for Cellular Systems

The efficient use of digital modulation techniques for cellular systems will depend greatly upon the choice of voice coder. On the other hand, a successful voice coder candidate needs to have a relatively low bit rate as well as to maintain a quality comparable to that offered by existing analogue cellular systems. Certainly, synthetic quality can never be accepted by system users and hence the use of vocoders is out of the question. Moreover, waveform coders with bit rates above 32 kbps entail a big sacrifice in terms of bandwidth and, in that sense, cannot compete with analogue cellular systems. Table 4.2 lists some values of transmission bit rate for various waveform and hybrid voice coders, which can achieve toll quality and communication quality [4.13]. It can be seen that hybrid voice coders can achieve an acceptable quality with bit rates between 7.2 and 16 kbps. In general, bit rate reduction means higher vulnerability to errors and hence additional error protection and

**Table 4.2** Transmission Bit Rates for Various Coders for Toll Quality and Communication Quality

Coder	Transmission Bit Rate (kbps)	
	Toll Quality	Communication Quality
Log PCM	56	36
ADM	40	24
ADPCM	32	16
SBC	24	9.6
Hybrid Waveform/Source	16	7.2

correction coding is needed to enhance the performance of the coder [4.14, 4.15]. We can conclude that hybrid voice coders with bit rates in the vicinity of 16 kbps can provide the required quality and hence can be considered adequate for cellular systems.

Much work has been devoted to the development of efficient voice coders for cellular systems which can provide a quality service [4.16, 4.17]. Other studies have been directed towards the choice of a voice coder for digital cellular systems by investigating and comparing existing 'state of the art' voice coders. Such studies were based upon computer simulations [4.18] and subjective tests [4.19–4.21]. A 16 kbps voice coder of the hybrid type was chosen for the Pan-European digital cellular system [4.19].

#### 4.4 SPECTRAL EFFICIENCY OF DIGITAL MODULATION TECHNIQUES WITHIN CELLULAR SYSTEMS

In Chapter 3, the spectral efficiency of analogue modulation techniques within cellular systems was evaluated. Although the method is mainly designed for analogue modulation techniques, it can be easily adapted for digital modulation. This is mainly because the interference models used are independent of the modulation technique employed and whether the signal is analogue or digital. Hence, Equation (3.120) holds just as well for digital modulation techniques:

$$\eta_M = \frac{3}{B_c(6a)^{2/\alpha}A}. \quad (4.6)$$

Nonetheless, because of the nature of digital systems and the way their parameters are defined, it may be necessary to evaluate the

channel spacing and, perhaps, the protection ratio in the above equation, using such parameters.

First, the channel spacing  $B_c$  may not be specified in kHz and the coded speech is given in terms of kbps. Second, it may be possible to use some objective measures such as the BER and  $E_b/N_o$  to obtain a value for the protection ratio. Two approaches to evaluate the channel spacing and the protection ratio for digital systems are now discussed. The channel spacing will be referred to as the 'equivalent channel spacing' for distinction from analogue modulation techniques.

#### 4.4.1 Practical or Subjective Approach

This is a simple method which combines the voice coder bit rate in kbps and the speed of the digital modulation technique in bps/Hz. In this way, the equivalent channel spacing is given by:

$$\text{equivalent channel spacing (kHz)} = \frac{\text{voice coder bit rate (kbps)}}{\text{digital modulation speed (bps/Hz)}}. \quad (4.7)$$

The ideal digital modulation speed could be used to obtain a theoretical value for the equivalent  $B_c$ . Alternatively, the digital modulation speed which can be reached in practice is used in order to achieve a realistic value for the equivalent  $B_c$ . Table 4.3 shows theoretical and practical values for the equivalent  $B_c$  necessary to transmit speech assuming the use of a 16 kbps voice coder.

In this approach, the protection ratio required for a certain quality voice reception is subjectively assessed under fading and shadowing conditions in exactly the same way as for analogue modulation systems.

#### 4.4.2 Theoretical or Objective Approach

In this approach, the equivalent channel spacing is evaluated in the same way as before. The protection ratio, however, is assessed objectively based on the BER and the  $E_b/N_o$  of each digital modulation technique. One method to assess the protection ratio objectively for various digital modulation techniques is found in [4.22] and is based on the following assumptions:

(a) Optimum processing and performance can be achieved for all digital modulation techniques.

**Table 4.3** Theoretical and Practical Equivalent Channel Spacing and Objective Protection Ratio for Various Digital Modulation Techniques

	Digital Modulation and Detection	Theoretical		Practical		Objective Protection Ratio (dB) $BER = 10^{-2}$ (Fading)
		Speed (bps/Hz)	Equivalent $B_c$ (kHz)	Speed (bps/Hz)	Equivalent $B_c$ (kHz)	
AM	ASK-Envelope	1	16	< 0.8	> 20	19
	ASK-C	1	16	0.8	20	17
	QAM	2	8	1.7	9.4	17
	QPR	2.5	6.4	2.25	7.1	20.5
FM	16-QAM	4	4	3.0	5.3	27.5
	FSK ( $h = 1$ ) – NC	1	16	0.8	20	20
	CP-FSK ( $h = 0.7$ ) – NC	1	16	1.0	16	18
	CP-FSK ( $h = 0.7$ ) – C	1	16	1.0	16	13
PM	MSK ( $h = 0.5$ ) – C	2	8	1.9	8.4	17
	MSK ( $h = 0.5$ ) – DE	2	8	1.9	8.4	20
	BPSK-C	1	16	0.8	20	14
	DE-BPSK	1	16	0.8	20	17
	DPSK	1	16	0.8	20	17
	DQPSK	2	8	1.8	8.9	23
	QPSK	2	8	1.9	8.4	16.5
	8-PSK	3	5.3	2.6	6.2	21.3
AM/PM	16-PSK	4	4	2.9	5.5	27
	4-APK	2	8	< 2	> 8	16.5
	8-APK	3	5.3	2.8	5.7	19.8
	16-APK	4	4	3.3	4.8	24

C, Coherent; NC, Non-coherent; DE, Differential Encoding. Data taken from a variety of Sources. QAM/APK belong to the same family and should in theory have the same performance.

- (b) A 16 kbps voice coder is used with the required quality maintained.
- (c) A random BER of less than 1 in  $10^2$  is adequate for the required voice quality.
- (d) Only one bit error occurs per symbol in  $M$ -ary digital modulation techniques.

Based on the above assumptions, the signal power from the desired digital signal can be expressed in terms of the energy per bit  $E_b$  multiplied by the bit rate  $F_b$ :

$$S = E_b F_b. \quad (4.8)$$

Similarly, the interfering signal power from the undesired digital signal is given by multiplying the interference density  $N_o$  by the required bandwidth occupancy  $B_c$ :

$$I = N_o B_c. \quad (4.9)$$

For an ideal  $M$ -ary digital modulation technique:

$$B_c = \frac{F_b}{\log_2 M}. \quad (4.10)$$

Combining Equations (4.8), (4.9) and (4.10):

$$\frac{S}{I} = \left( \frac{E_b}{N_o} \right) \log_2 M \quad (4.11)$$

where  $M$  is the number of levels in the  $M$ -ary digital modulation technique. Also,  $\log_2 M$  is the ideal speed of the digital modulation technique. Table 4.3 shows objective protection ratio values for various digital modulation techniques needed for a BER of  $10^2$  in Rayleigh fading, using the above method.

#### 4.4.3 Comparison of the Subjective and Objective Approaches

The evaluation of the equivalent channel spacing of digital modulation techniques using Equation (4.7), appears to be satisfactory. However, the objective approach to the evaluation of the protection ratio has the following drawbacks:

- (a) It inherently assumes that the interference conforms to the AWGN model, which is not true considering the number of significant interferers within the cellular system.
- (b) In a mobile radio environment, errors occur in bursts. Consequently, the assumption of only one bit error per symbol in  $M$ -ary digital systems does not hold.
- (c) The BER as an objective quality measure does not reflect all significant aspects of voice quality. Other measures, such as voice processing delay time, speech naturalness and talker recognizability, are also necessary. Besides, any specified BER cannot guarantee quality and will very much depend on the voice coder employed.

For the above reasons, the objective approach is useful for a general comparison of voice coders combined with digital modulation techniques and in the absence of subjective protection ratio values. Nevertheless, the increasing use of the subjective approach to evaluate the protection ratio for cellular systems is inevitable.

## REFERENCES

- [4.1] Maloberti, A., 1987 'Definition of the Radio Subsystem for the GSM Pan-European Digital Mobile Communications System', *Proc. International Conference on Digital Land Mobile Radio Communications, Venice, 30 June - 3 July 1987* pp. 37-47
- [4.2] Shanmugam, K. S., 1979 '*Digital and Analog Communication Systems*' John Wiley and Sons, New York
- [4.3] Oetting, J. D., 1979 'A Comparison of Modulation Techniques for Digital Radio' *IEEE Trans. Commun.* **COM-27** (12) December 1979, pp. 1752-62
- [4.4] Clark, A. P., 1985 'Digital Modems for Land Mobile Radio' *IEE Proc.* **132, Pt F** (5), August pp. 348-62
- [4.5] Feher, K., 1981 '*Digital Communications: Microwave Applications*' Prentice-Hall, Englewood Cliffs, NJ
- [4.6] Noguchi, T., Radio, Y. and Nossek, J. A., 1986 'Modulation Techniques for Microwave Digital Radio' *IEEE Commun. Mag.* **24** (10) pp. 21-30
- [4.7] Proakis, J. G., 1983 '*Digital Communications*' McGraw-Hill, New York
- [4.8] Jakes, W. C., 1974 '*Microwave Mobile Communications*' John Wiley and Sons, New York
- [4.9] Maseng, T., 1987 'On Selection of System Bit-Rate in the Mobile Multipath Channel' *IEEE Trans. Veh. Technol.*, **VT-36** (2) May pp. 51-54

- [4.10] Dechambre, M. and Levy, A. J., 1987 'Limits of Data Rates in the Urban Mobile Channel', *37 IEEE Vehicular Technology Conference, Tampa, Florida, 1-3 June 1987* pp. 541-6
- [4.11] Jayant, N. S. and Noll, P., 1984 *'Digital Coding of Waveforms: Principles and Applications to Speech and Video, Prentice-Hall Signal Processing Series* Prentice-Hall, New York
- [4.12] Flanagan, J. L., 1972 *'Speech Analysis: Synthesis and Perception'* Second Edition, Springer-Verlag, New York
- [4.13] Flanagan, J. L., *et. al.*, 1979 'Voice Coding', *IEEE Trans. Commun. COM-27* (4) April 1979 pp. 710-37
- [4.14] Hirohito, S. and Toshio, M., 1988 'An Error Protected 16 kbit/s Voice Transmission for Land Mobile Radio Channel' *IEEE J. Sel. Areas Commun. SAC-6* (2) February pp. 346-52
- [4.15] Goodman, D. J. and Sundberg, C. W., 1983 'Quality of Service and Bandwidth Efficiency of Cellular Mobile Radio with Variable Bit-Rate Speech Transmission' *IEEE Trans. Veh. Technol. VT-32* (3) August pp. 211-7
- [4.16] McLaughlin, M. J. and Rasky, P. D., 1988 'Speech and Channel Coding for Digital Land-Mobile Radio' *IEEE J. Sel. Areas Commun. SAC-6*, No. (2) February pp. 332-45
- [4.17] Hanes, R. B., Goody, C. and Atkins P., 1986 'An Efficient 16 kbit/s Speech Coder for Land Mobile Radio Applications' *Second Nordic Seminar on Digital Land Mobile Radio Communications, 14-16 October 1986* pp. 239-42
- [4.18] Lee, S. U., Chung, Y. M. and Kim J. M., 1987 'Performance Comparison Between the SBC and CVSD Over the Rayleigh Fading Channel' *37th IEEE Vehicular Technology Conference, Tampa, Florida, 1-3 June 1987* pp. 512-8
- [4.19] Natvig, J. E., 1988 'Evaluation of Six Medium Bit-Rate Coders for the Pan-European Digital Mobile Radio System' *IEEE J. Sel. Areas Commun. SAC-6* (2) February pp. 324-31
- [4.20] Hoyle, R. D. and Falconer, D. D., 1987 'A Comparison of Digital Speech Coding Methods for Mobile Radio Systems' *IEEE J. Sel. Areas Commun. SAC-5* (5), June pp. 915-20
- [4.21] Kinoshita, K., Hata, M. and Nagabuchi, H., 1984 'Evaluation of 16 kbit/s Digital Transmission for Mobile Radio' *IEEE Trans. Veh. Technol. VT-33* (4) November pp. 321-7
- [4.22] Bateman, A. and McGeehan J. P., 1986 'A Survey of Potential Narrow-band Modulation Techniques for Use in Satellite and Cellular Systems' *Second Nordic Seminar on Digital Land Mobile Communications, 14-16 October 1986* • pp. 42-7



# 5

## ***Spectral Efficiency of Multiple Access Techniques***

### **5.1 INTRODUCTION**

The term 'multiple access' seems to have its origin in satellite communications [5.1]. Other terms such as multiplexing and trunking are sometimes used to mean the same thing. The term multiple access applies to the mixing of RF signals. However, the term multiplex applies to the mixing of signals at baseband frequency [5.1]. The aim of multiple access techniques is to combine signals from different sources on a common transmission medium in such a way that, at their destinations, the different signals or channels can be separated without mutual interference [5.2]. In cellular mobile radio, the need for multiple access techniques arises from the necessity to share a limited resource of the radio spectrum amongst many users. In other words, multiple access techniques permit many users to share a common communication medium resource (i.e. a frequency band forming a group of RF channels), hopefully, in the most efficient way.

Modulation and multiplexing are often employed side by side in communication systems. Although the terms modulation and multiplexing are often mixed and interchanged, they are, completely different matters and as such this can cause considerable misunderstanding. A clear understanding of the difference between the two can be gained with the help of the following definitions.

*Modulation* is the process used to transform information signals into transmission signals.

*Multiplexing* is the process used to separate different information channels transmitted via the same medium.

Following the above definitions, the terms modulation and multiple access techniques are used to describe two entirely different processes and hence, the efficiency which they contribute is separable.

The aim of this chapter is to devise a method by which the spectral efficiency of different multiple access techniques within cellular systems can be evaluated. In order to do that, a brief description of the basic multiple access techniques is given, stating the advantages and disadvantages of each technique. The theoretical efficiency of the various multiple access techniques is then discussed, emphasizing the factors which can influence their values. To derive the efficiency of a multiple access technique it is important to consider its performance in practice. In defining a multiple access efficiency factor, the practical efficiency of each multiple access technique is given in a mathematical form and as a function of some system parameters which are easily obtained. Using these mathematical equations, the efficiency of different multiple access techniques is evaluated based on the available data of present and proposed cellular land mobile radio systems. In Chapter 6, the overall spectral efficiency of a cellular land mobile radio system is obtained by combining the results of the spectral efficiencies of both the modulation and the multiple access techniques employed.

## 5.2 BASIC MULTIPLE ACCESS TECHNIQUES

In cellular land mobile radio systems, multiple access techniques permit many users to share a limited resource of the radio spectrum, presumably in the most efficient way. In the sense of voice channel assignment to the users of the system, multiple access can be classified into three categories as follows.

- (a) *Pre-assignment*. In such systems, the user is permanently allocated (assigned) a voice channel whether in use or not.
- (b) *Demand assignment*. In this case the user is assigned a voice channel on request (demand) from a group of available channels. The channel is then relinquished back to the system when the call is over and the same channel is then available to other users.
- (c) *Random access*. In random access systems, the contending users try to access the channels at random and without reference to the system. Collisions between users trying to access the same channel are probable, and the channels are released back to the system when the call is over.

Although, the above assignment methods arose in satellite communication systems [5.3], they are also applicable to mobile radio systems. Pre-assignment is very inefficient to use in cellular systems, although some channels need to be pre-assigned to emergency services within the system. Demand assignment is the most efficient and is commonly used in present cellular systems. Random access is a possibility, but the collision rate becomes unacceptably high during the busy hour. In fact, some systems use random access as part of the demand assignment architecture for the purpose of accessing a setup channel by the users [5.4]. In terms of separating the signals, there are three basic multiple access techniques: frequency division multiple access (FDMA), time division multiple access (TDMA) and code division multiple access (CDMA). The efficiency of multiple access techniques in terms of signal separation is relevant and related to the modulation efficiency and hence will be treated in this chapter. Channel assignment techniques are equally applicable to all cellular systems and their efficiency will not be considered here.

### 5.2.1 Frequency Division Multiple Access (FDMA)

With the FDMA technique, users share the radio spectrum in the frequency domain. This is achieved by dividing the total bandwidth available to the system into narrow frequency sub-bands (voice channels), as illustrated in Figure 5.1(a). The channel spacing is governed by the modulation technique employed, for example, it is 5 kHz for SSB and 25 or 30 kHz for FM. Each of the voice channels is allocated to one and only one of the contending users for the duration of the communication. FDMA is most suitable for analogue modulation systems such as FM, AM and SSB. These modulation systems use the FDMA technique combined with frequency duplexing.

#### *Advantages of FDMA*

- (a) No doubts on its feasibility.
- (b) Mature and reliable technology.
- (c) Flexible technology.
- (d) No channel equalisation is required.

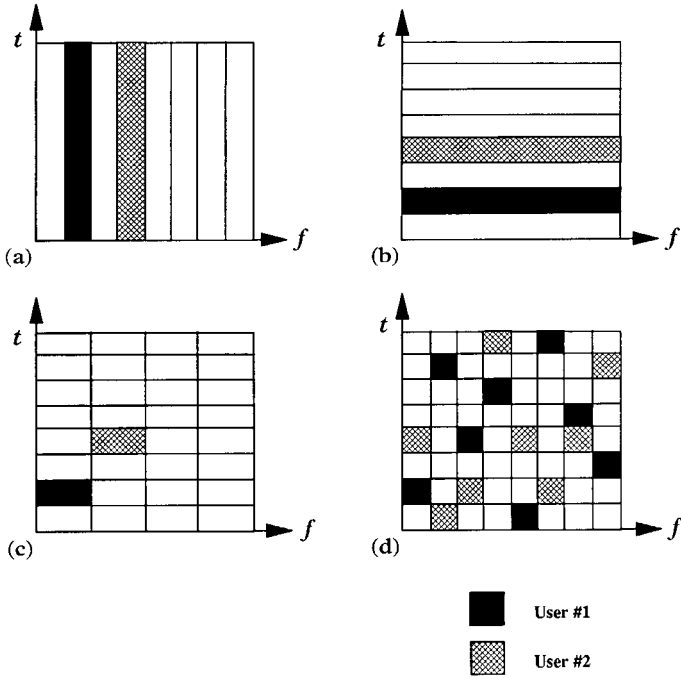

**Figure 5.1** Basic Multiple Access Techniques. (a) FDMA. (b) WB-TDMA. (c) NB-TDMA. (d) CDMA

*Disadvantages of FDMA*

- (a) Complexity of base station and the need for a duplexer in the mobile station.
- (b) Stability requirements of carrier frequencies, in particular, for narrow channel spacings such as used with SSB.
- (c) Protection against deep fading is difficult especially for slow-moving mobiles.

**5.2.2 Time Division Multiple Access (TDMA)**

With the TDMA technique, users in the system share the radio spectrum in the time domain. This is achieved by allocating a time slot to one and only one of the contending users for the duration of the communication. During this time slot the user has access to the full frequency band available to the system. This is referred to as wideband TDMA (WB-TDMA) (see Figure 5.1(b)). Alternatively,

in narrowband TDMA (NB-TDMA), the user is given access only to part of the frequency band available to the system, as shown in Figure 5.1(c). In NB-TDMA, the channel spacing is increased to allow time division between a few users but it remains below the coherence bandwidth. In WB-TDMA, however, the channel spacing is well above the coherence bandwidth. TDMA techniques are most suitable for digital systems.

#### *Advantages of NB-TDMA*

- (a) Mature technology.
- (b) The requirements on oscillator stability are less stringent than in FDMA.
- (c) It is possible to avoid duplex filters in the mobile station by selecting different time slots for transmission and reception.
- (d) Encryption can be easily implemented.

#### *Disadvantages of NB-TDMA*

- (a) Possibly some equalization problems.
- (b) Synchronisation is required between mobile and base stations, which may present a serious problem in a mobile environment.
- (c) The need for preamble and guard time overheads may have a significant impact on spectrum efficiency.

#### *Advantages of WB-TDMA*

- (a) Inherent frequency diversity against multipath fading.
- (b) It is possible to avoid duplex filters in the mobile station by selecting different time slots for transmission and reception.

#### *Disadvantages of WB-TDMA*

- (a) Less mature than NB-TDMA systems.
- (b) A difficult equalization problem which requires an efficient equalization system.

- (c) Synchronization is required between mobile and base stations, which may present a serious problem in a mobile environment.
- (d) Requires large continuous frequency bands which may not be always available everywhere.
- (e) High-speed processing is necessary.
- (f) Need for power control to overcome the near-to-far effect in which power from a user near the base station would overwhelm distant users in the same cell.
- (g) The need for preamble and guard time may have a significant impact on spectrum efficiency.

### 5.2.3 Code Division Multiple Access (CDMA)

This technique has also been called spread spectrum multiple access (SSMA) [5.5]. In spread spectrum techniques, the transmitted signal is spread over a wide frequency range, much wider, in fact, than the minimum bandwidth required to transmit the information being sent [5.6]. Basically, with the CDMA technique, each user in the system is assigned a unique set of time–frequency waveforms which are governed by a unique pseudorandom user code. Each user can then access the time–frequency domain, at any time, in a unique manner according to his or her own unique code (see Figure 5.1(d)). These user codes are so designed that low cross-correlation values are maintained and co-user interference is kept acceptably low. There are various ways by which the user can exploit the time–frequency domain and these depend upon the spread spectrum method employed by the CDMA technique. Possible spread spectrum techniques are described in the literature [5.5, 5.6] and can be summarized as follows.

- (a) *Direct Sequence (DS)*. This is also known as pseudo-noise (PN), in which case the carrier is modulated by a digital code sequence whose bit rate (referred to as ‘chip’ rate as a matter of distinction) is much higher than the information signal bandwidth. In its simplest form, the carrier is switched between two phases which are  $180^\circ$  apart, according to a binary code sequence (pseudorandom binary pattern). The receiver tracks the pseudorandom phase inversions using a stored replica of the code sequence.

(b) *Frequency Hopping (FH)*. In this technique, the carrier frequencies of the transmitter and receiver are changed at regular intervals. This change of frequency is governed by a code sequence which determines the order of frequency usage. In fact, frequency hopping is nothing more than FSK except that the set of frequency choices is greatly expanded. It is convenient to classify FH systems as fast hopping and slow hopping. In fast frequency hopping (FFH), the hopping rate significantly exceeds the information rate. In slow frequency hopping (SFH), however, the hopping rate is comparable to or less than the information rate.

(c) *Time Hopping (TH)*. In this technique, a code sequence governs the timing of the transmission. The sequence of transmission times is stored in the receiver which is used to track the transmissions, but otherwise ignores the channel. Pure time hopping has not found widespread application outside the military sector [5.5].

(d) *'Chirp' or pulse FM*. In this approach, the carrier frequency of a transmitted pulse is varied continuously (or swept) over a wide band over a period of time.

(e) *Hybrid forms*. Hybrid combinations of the previous techniques are possible. The most often used hybrid spread spectrum techniques are:

- frequency hopping and direct sequence (FH-DS);
- time and frequency hopping (TFH);
- time hopping and direct sequence (TH-DS).

### *Advantages of CDMA*

(a) Resistance to intentional and unintentional narrowband interference.

(b) Resistance to fading which is provided by the inherent frequency diversity characteristic of FH/CDMA.

(c) Any user can access the system at any time without waiting for a free channel.

(d) There is no hard limit on simultaneously active users. When the number of active users exceeds the design value, the result is a degradation of performance for all users rather than denial of access.

- (e) Because each user retains his or her unique signal set permanently, there is no channel switching or address changes as the user moves from cell to cell.
- (f) Emergency services can be accommodated in the system – even in the presence of system overload – without assigning a dedicated channel or denying other users access to the system.
- (g) Co-existence in the same frequency band as conventional narrowband systems is possible if full capacity of CDMA systems is not required.
- (h) Permits efficient encryption against casual listeners since each potential user is assigned a unique code.
- (i) No established industrial interests that complicate standardization.

#### *Disadvantages of CDMA*

- (a) Complex and expensive hardware is required. This is due to the need for fast hopping frequency synthesizers, digitized voice, fast processors, etc.
- (b) A dynamic control of mobile transmitter power is essential in order to mitigate the near-to-far effect.
- (c) Fully coherent detection is not possible in a fading mobile environment. Furthermore, synchronization at the ‘chip’ level is required which is extremely difficult to achieve.
- (d) Designing a large number of individually unique orthogonal (or near orthogonal) codes for thousands of users proves to be a formidable task. Loss of orthogonality will result in co-user interference which will affect the efficiency as well as the quality of the system.
- (e) Free user access to the channels will eventually cause the system to collapse by reaching a stage when the quality of service is unacceptable for all users. In this case, adopting a strategy of blocked calls or forced termination may be necessary.
- (f) No practical experience within cellular land mobile radio systems is available.
- (g) There are some doubts on spectral efficiency – this matter is to be investigated.



### 5.3 THEORETICAL EFFICIENCY OF MULTIPLE ACCESS TECHNIQUES

Analogue cellular land mobile radio systems traditionally employ the FDMA technique combined with frequency duplexing. Some cellular systems use a wideband TDMA technique such as the German cellular system CD 900 which was proposed for use in Europe [5.7]. A narrowband TDMA technique was envisaged for the second-generation Pan-European cellular system for reasons of cost, flexibility and compatibility with digital techniques [5.8, 5.9]. Surprisingly, a frequency hopping SSMA technique was also suggested for high-capacity cellular systems [5.10]. Furthermore, a SFH/CDMA cellular system (the SFH 900) has been developed and an experimental network was built in France in 1986 [5.11]. The theoretical efficiencies of various multiple access techniques are now discussed, emphasizing the factors which can influence their values.

#### 5.3.1 Multiplexing with Orthogonal Signals

To compare the spectral efficiency of various multiple access techniques, it is useful to think in terms of time–frequency signal space. Given a total frequency band of  $B_t$  Hz, the theoretical spectral efficiency of different multiple access techniques within a given time duration  $T_g$  seconds, is tested. In this comparison, modulation efficiency considerations are excluded such that any modulation technique is assumed to be equally applicable to any multiple access technique. Also, a distortion-free transmission is assumed. In this assessment, the multiple access techniques considered to meet two objectives. First, maximum utilization of the time–frequency signal space. Second, utilization of the time–frequency signal space in such a way that no mutual interference will exist between multiplexed signals. While the first objective ensures maximum spectral efficiency is achieved by the multiple access technique, the second is necessary for signal quality considerations. To ensure that no mutual interference will exist between multiplexed signals, it is sufficient to ensure that channel signals are built up from non-overlapping sets of signals in the time–frequency signal space. In other words, multiplexed signals need to be orthogonal. For two signals  $s_i$  and  $s_j$  to be orthogonal, they have to meet the following condition [5.12]:

$$\int_{-\infty}^{+\infty} s_i(t)s_j(t) dt = 0 \quad \text{for } i \neq j. \quad (5.1)$$

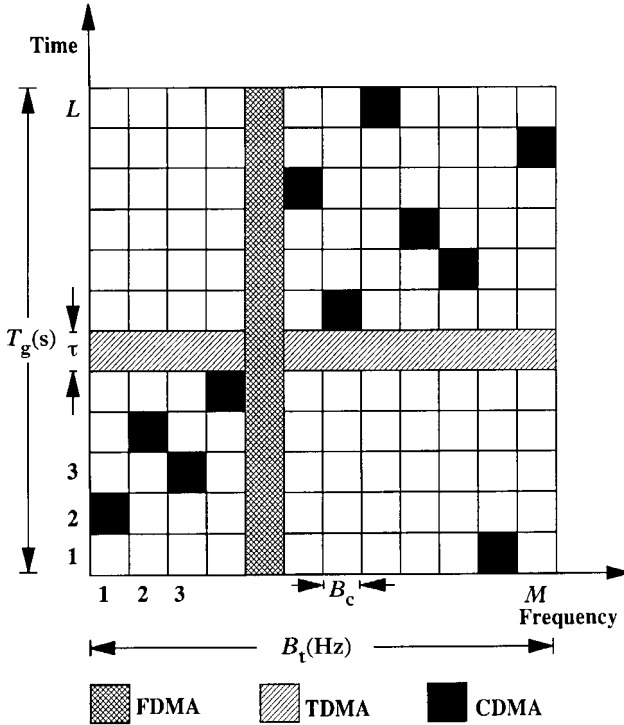

Figure 5.2 Time-Frequency Signal Space Divided into  $L \times M$  Cells

In Figure 5.2, the time-frequency signal space with dimensions  $B_t T_g$  is divided into  $L \times M$  'cells', where each cell defines an orthogonal set of time-frequency signals. It is important to note that, for any given modulation technique, the information sent is proportional to the time-frequency product, provided that the condition of orthogonality holds. With FDMA  $L = 1$  and the time-frequency signal space is divided into  $M$  orthogonal 'frequency' channels with total dimensions  $B_t T_g$ . Similarly, for TDMA,  $M = 1$  and the time-frequency signal space is divided into  $L$  orthogonal 'time' channels with total dimensions  $B_t T_g$ . In the case of CDMA, each user is assigned a unique code which determines his or her use of the  $L \times M$  cells in the time-frequency signal space. In FH/CDMA, for instance, the code assigned to the user determines a unique frequency hopping pattern. Provided that such codes or 'patterns' are orthogonal, the CDMA technique can provide a number of orthogonal 'sequency' channels with total dimension of  $B_t T_g$ .

As a consequence, we can conclude that all the multiple access techniques described above potentially have a 100% relative spectral

efficiency provided the channels are orthogonal. Furthermore, since the condition of orthogonality ensures that no mutual interference exists between multiplexed signals, it can also be concluded that in the case of distortion-free transmission, the quality of transmission is independent of the multiplexing method provided that the multiplexing is orthogonal.

### 5.3.2 Multiplexing with Non-orthogonal Signals

We need to examine the effect of multiplexing with non-orthogonal signals on the theoretical efficiency of multiple access techniques, in comparison with orthogonal methods. To facilitate this comparison, Shannon's law is assumed for all multiple access techniques. Furthermore, FDMA and synchronous TDMA as orthogonal multiplexing techniques will be compared with direct sequence (or pseudo-noise) SSMA as an example for non-orthogonal multiplexing. In a system with non-orthogonal signals such as DS/SSMA the signal to noise ratio will be very low and all other channels will act as noise [5.6]. For a given period of time  $T_g$  and a given channel spacing  $B_c$ , the capacity is given by:

$$C = B_c T_g \log_2 \left[ 1 + \left( \frac{S}{N} \right) \right] \quad (5.2)$$

where  $S/N$  is the signal to noise ratio. From the above equation it can be seen that under a very small signal to noise ratio, transmission is still possible provided that the channel bandwidth is sufficiently large.

Now, consider an available bandwidth  $B_t$  Hz which is divided into  $M$  channels (either in the frequency or time domain), a received signal power per channel  $S$  W and noise assumed to be white with spectral density  $N_o$  W/Hz. For orthogonal signal channels (FDMA and synchronous TDMA), the information capacity per channel is found to be:

$$C_{\text{or}} = \left( \frac{B_t T_g}{M} \right) \log_2 \left[ 1 + \left( \frac{SM}{N_o B_t} \right) \right]. \quad (5.3)$$

For non-orthogonal signal channels (DS/SSMA), the capacity per channel is:

$$C_{\text{non}} = B_t T_g \log_2 \left[ \frac{1 + S}{[S(M - 1) + N_o B_t]} \right]. \quad (5.4)$$

Assuming that the undesired signals act as white noise on the desired signal and that all signals are received with equal power  $S$ , it can be verified that [5.13]:

$$C_{\text{or}} > C_{\text{non}} \quad \text{for} \quad S > 0.$$

This leads to the important conclusion that even if the transmission system meets Shannon's capacity law, orthogonal multiple access techniques are superior in their spectral efficiency to non-orthogonal multiple access techniques. It also leads to the conclusion that loss in orthogonality causes a considerable loss in capacity.

### 5.3.3 Synchronous and Asynchronous Multiplexing

It was shown previously that all multiple access techniques have a 100% relative spectral efficiency provided that the channels are orthogonal. This result holds so long as a distortion-free transmission is guaranteed. In land mobile radio systems, however, the transmission medium introduces phase shifts between multiplexed signals. Not only are path lengths between transmitters and receivers unequal, but also they are often varying. Under such circumstances, synchronism between transmitters and receivers is lost and the orthogonality among the signal channels is destroyed, that is, with the exception of FDMA. In FDMA, the multiplexed signals remain orthogonal under varying conditions including that of a land mobile radio environment. For TDMA and CDMA, the loss of orthogonality will result in a non-zero cross-correlation between the signals. Consequently, co-user or multiple access interference will result, and that will cause signal quality deterioration, even in the absence of receiver noise. Moreover, since loss of orthogonality leads to a considerable loss in spectral efficiency, asynchronous multiplexing will always be inferior in spectral efficiency to synchronous multiplexing.

Theoretical studies have been undertaken to find an upper mathematical bound for the spectral efficiency of asynchronous multiple access techniques in terms of the maximum allowable cross-correlation between any two signals, as compared with the synchronous situation [5.14]. If the multiple access interference could be modelled as additive white Gaussian noise (AWGN), the relative efficiency of asynchronous multiple access, in general, approaches 69% for FH/CDMA and 72% for DS/CDMA [5.14].

### 5.3.4 TDMA Versus FDMA Using the Sampling Theorem

Assume we have  $N$  input message signals, band-limited to  $B_c$  Hz. With FDMA, using the narrowest possible band modulation, SSB say, the bandwidth of the multiplexed signals will be  $NB_c$  Hz. With TDMA, assuming a sampling rate of  $f_s$  for each channel, then the multiplexed message signals consist of a series of sample points separated in time by  $1/Nf_s$  seconds (see Figure 5.3). According to the sampling theorem, these signal points can be completely described by a continuous waveform  $m_c(t)$  that is band-limited to  $Nf_s/2$ . At the receiver, assuming perfect synchronism,  $m_c(t)$  is sampled and the sample values are distributed to the appropriate channels. If the sampling rate is close to the Nyquist rate, i.e.  $f_s \approx 2B_c$ , then the bandwidth of the TDMA multiplexed signals is:

$$(N2B_c)/2 = NB_c \text{ Hz}$$

which is the same as for FDMA.

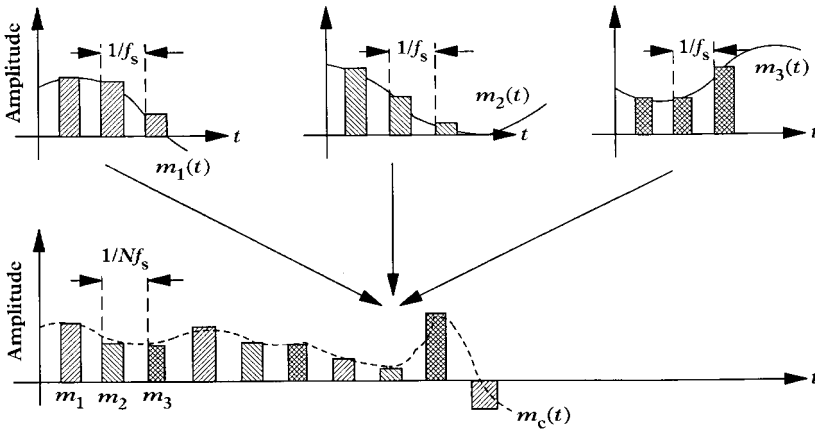

Figure 5.3 TDMA Waveforms

## 5.4 PRACTICAL EFFICIENCY OF MULTIPLE ACCESS TECHNIQUES

To derive the efficiency of a multiple access technique, it is crucial to consider its performance in practice because implementation limitations will certainly reduce its theoretical efficiency. Furthermore, the

efficiency of a multiple access technique may vary with different applications. In FDMA, for instance, the spectral efficiency is reduced by the need for guard bands between channels to reduce filter roll-off requirements and also to accommodate frequency shifts due to oscillator instability and Doppler shifts due to user mobility within the cellular system. Similarly, in TDMA, the spectral efficiency is reduced by the inclusion of guard time and synchronization preamble. Also, because of the time delay spread phenomenon in land mobile radio systems, the signalling rate in the frequency band around 900 MHz is limited [5.15, 5.16], so that wideband TDMA or DS/CDMA in the full 20 MHz band usually available is not possible with any degree of efficiency.

## 5.5 MULTIPLE ACCESS EFFICIENCY FACTOR

To be able to calculate the practical spectral efficiency of various multiple access techniques, we need to define what we mean by the practical efficiency of a multiple access technique. The basic idea is to visualize the way by which voice channels (signals) are 'fitted' in the time–frequency domain for different multiple access techniques. It is of no concern to us here how wide or narrow the voice channel is, since this is taken care of by the modulation technique efficiency considerations. In digital systems, where source coding, channel coding or other spectrum spreading techniques are employed as a protection against multipath fading and co-channel interference, we choose to consider this parameter as part of the consideration of the modulation technique efficiency. Power and interference are also considered as part of the modulation efficiency. On the other hand, set-up channels, common signalling channels, supervision channels, etc., will be considered as part of the multiple access spectral efficiency. In general, the use of the frequency–time domain for any purpose apart from voice communication will be treated as an 'overhead'. This is because the total spectral occupancy of such overheads may differ from one multiple access technique to the other, and from one application to another.

### *Definition*

We define a multiple access efficiency factor as:

The ratio of the total time–frequency domain dedicated to *voice* transmission to the total band available to the system.

From the above definition, the multiple access efficiency factor is dimensionless and has an upper limit of one. Mathematically, the multiple access efficiency factor  $\eta_T$  (T for trunking) has to be defined for different multiple access techniques. Moreover, since multiple access techniques are defined in both the time and frequency domains,  $\eta_T$  is given by:

$$\eta_T = (\text{efficiency in the frequency domain}) \times (\text{efficiency in the time domain}). \tag{5.5}$$

### 5.5.1 Multiple Access Efficiency Factor for FDMA

For a pure FDMA technique, the allocated frequency band is being exploited all the time (see Figure 5.1(a)), and the efficiency of FDMA in the time domain is 100%. In this case,  $\eta_T$  for FDMA has only to be evaluated in the frequency domain. Hence, for a FDMA technique (Figure 5.4):

$$\eta_T = \frac{\text{total frequency band dedicated for voice transmission}}{\text{total total frequency band available to the system}} \tag{5.6}$$

$$\eta_T = \frac{\text{total frequency band} - \text{total band used for overheads}}{\text{total frequency band}} \tag{5.7}$$

Equation (5.6) can be re-written as (see Figure 5.4):

$$\eta_T = \frac{B_c M_a}{B_t} \tag{5.8}$$

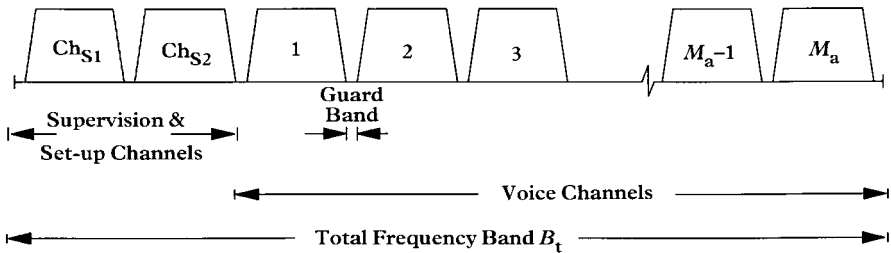

**Figure 5.4** FDMA Structure Illustrating Voice Channels, Set-up Channels, Supervision Channels and Guard Bands

where  $B_c$  is the channel spacing in MHz,  $B_t$  is the total frequency band available to the system, also in MHz, and  $M_a$  is the total number of voice channels available to the system, excluding overheads such as guard bands, set-up and supervision channels, etc.

It can be seen from Equation (5.8) that  $\eta_T$  is dimensionless and has as upper limit of one. Also, the multiple access efficiency factor percentage, can be obtained by multiplying Equation (5.8) by 100%.

**5.5.2 Multiple Access Efficiency Factor for WB-TDMA**

For wideband TDMA, the users in the system share the available frequency band in the time domain (see Figure 5.1(b)). During his/her time slot, the user has access to the full frequency band available to the system. Hence, the efficiency of WB-TDMA in the frequency domain is 100%. In this case,  $\eta_T$  has only to be considered in the time domain. Considering a time frame in which the user is allocated a time slot which repeats periodically,  $\eta_T$  for WB-TDMA can be defined as:

$$\eta_T = \frac{\text{total frame time dedicated for digitized voice transmission}}{\text{total frame time available to the system}} \tag{5.9}$$

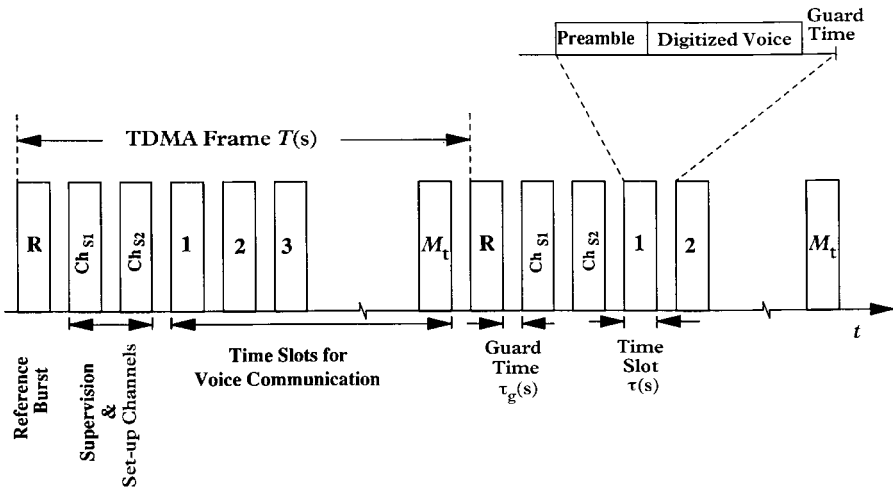

**Figure 5.5** TDMA Structure Illustrating Time Slots, Reference Burst, Supervision Channels and Set-up Channels



In Equation (5.9), the total time dedicated for digitized voice transmission in the system is obtained by the maximum number of time slots available to the users  $M_t$  multiplied by the duration of each time slot  $\tau$  seconds. The total frame time available to the system is the frame which accommodates all users' time slots, guard times, set-up time slots, supervision time slots and all other possible overheads which are not used for voice transmission (see Figure 5.5). Hence, Equation (5.9) can be re-written as:

$$\eta_T = \frac{\tau M_t}{T} \quad (5.10)$$

where  $\tau$  is the time slot duration in seconds,  $T$  is the frame duration in seconds, and  $M_t$  is the number of time slots dedicated for voice transmission in a frame.

Another way of defining  $\eta_T$  for WB-TDMA is:

$$\eta_T = [T - (\text{Total time for signalling, set - up, supervision, guard, etc.})]/T \quad (5.11)$$

#### *An Alternative method for WB-TDMA technique*

TDMA is usually employed in conjunction with digital modulation systems. Consequently,  $\eta_T$  for WB-TDMA can be evaluated by considering the speed of the digital modulation technique in bps/Hz;  $\eta_T$  is then defined as:

$$\eta_T = \frac{\text{voice channel bit rate} \times \text{number of voice channels available}}{\text{total bandwidth available} \times \text{speed of digital modulation}} \quad (5.12)$$

$$\therefore \eta_T = \frac{\text{voice channel in bps} \times M_d}{\text{total bandwidth in bps}} \quad (5.13)$$

Equation (5.12) can be re-written as:

$$\eta_T = \frac{\left( \frac{\text{voice channel bit rate}}{\text{speed of digital modulation}} \times \text{number of voice channels available} \right)}{\text{total bandwidth available}}$$

$$\therefore \eta_T = \frac{\text{equivalent voice channel spacing (in Hz)} \times M_d}{\text{total bandwidth (in Hz)}} \quad (5.14)$$

In Equation (5.14), using the speed of the digital modulation technique in bps/Hz, the voice channel is transformed from bps to Hz. Using Equation (5.14), the spectral efficiency of WB-TDMA can be evaluated in the frequency domain.

### 5.5.3 Multiple Access Efficiency Factor for NB-TDMA

In narrowband TDMA, the user is given access only to part of the frequency band available to the system (see Figure 5.1(c)). Unlike FDMA and WB-TDMA, the signal is trunked in both the frequency and the time domains. Consequently,  $\eta_T$  for the NB-TDMA technique needs to be considered in both the time and the frequency domains. Hence,  $\eta_T$  for NB-TDMA can be defined as:

$\eta_T = (\text{efficiency in the time domain}) \times (\text{efficiency in the frequency domain})$

$$\therefore \eta_T = \frac{\tau M_t}{T} \times \frac{B_u M_u}{B_t} \quad (5.15)$$

where  $B_u$  is the bandwidth which a user can have access to during his or her time slot,  $M_u$  is the number of users sharing the same time slot in the system, but having access to different frequency bands and  $\tau$ ,  $T$ ,  $M_t$  and  $B_t$  have their usual meanings as defined before.

In Figure 5.1(c),  $M_u = 4$  and  $B_u < (B_t/4)$ , since guard bands have to be introduced in the frequency domain.

### 5.5.4 Multiple Access Efficiency Factor for CDMA

Similar to NB-TDMA, the signal in CDMA is trunked in both the time and frequency domains. Nevertheless, it is more difficult to evaluate  $\eta_T$  for the CDMA technique since the user does not use the same frequency band and time slot during the communication time. In slow frequency hopping CDMA, for example, each user in the system is assigned a unique set of time–frequency waveforms, and hence can access the time–frequency domain in a unique manner. Furthermore, if such time–frequency waveforms have zero (or near zero) cross-correlation, then Equation (5.15) can be used to describe the efficiency of the CDMA technique. In fact,  $\eta_T$  for CDMA will be upper bounded by Equation (5.15) in the following fashion:

$$\therefore \eta_T \leq \frac{\tau M_t B_u M_u}{T B_t} \quad (5.16)$$

This is due to the difficulty of arranging the signals to occupy the entire time–frequency domain without any loss of efficiency. In other words, it is difficult to find enough orthogonal codes such that the signals occupy the entire time–frequency domain without ‘gaps’.

Conversely, there are situations where it is not practical or possible to use orthogonal spread spectrum codes. In particular, in high-capacity cellular systems with thousands of potential users, multiple access interference will occur and signal quality will deteriorate. Hence, by using non-orthogonal CDMA, it may be possible to obtain higher values of  $\eta_T$  at the expense of poorer signal quality. Poor signal quality will, in turn, reduce the modulation efficiency. In this case, a compromise between the two objectives is necessary.

**5.5.5 Typical Values for  $\eta_T$**

A summary of the efficiency factor for various multiple access techniques is shown in Table 5.1. Typical values for  $\eta_T$  can be derived by considering multiple access techniques employed in practice. The first-generation cellular systems were predominantly analogue FM/FDMA based systems [5.17]. Consequently, such situation permits easy evaluations of  $\eta_T$ . From studies based on the UK system TACS and the US system AMPS [5.17], the overheads are mainly supervision and set up channels which form between 5 and 7% of the total number of channels; guard bands being considered as part of the channel spacing  $B_c$ . Therefore, a typical value of  $\eta_T$  can be expected to be in the range of 0.95 to 0.90.

The second-generation cellular systems proposed for Europe [5.8], North America [5.18] and Japan [5.19] were mainly digital in nature and are based upon TDMA, FDMA and, very rarely, CDMA

**Table 5.1** Multiple Access Efficiency Factor for Various Multiple Access Techniques.  $\eta_T$  is the Product of the Multiple Access Efficiency in the Frequency Domain and the Multiple Access Efficiency in the Time Domain

Multiple Access Techniques	Multiple Access Efficiency Factor	Overheads
FDMA	$B_c M_a / B_t$	Guard bands, supervision and set-up channels
WB TDMA	$\tau M_t / T$	Guard time, reference burst, preamble and synchronization, etc.
NB TDMA	$(\tau M_t / T) \times (B_u M_u / B_t)$	Same as FDMA and WB-TDMA
CDMA	$< (\tau M_t \times B_u M_u) / T B_t$	Mainly co-user interference

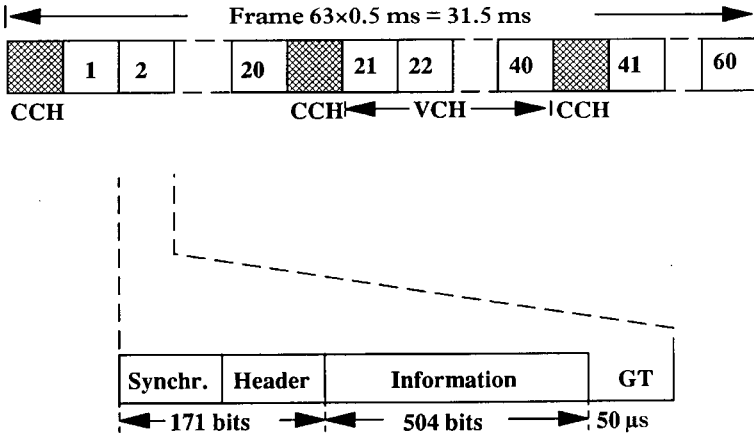

**Figure 5.6** CD 900 WB-TDMA Frame Structure. CCH, Control Channel; VCH, Voice Channel; GT, Guard Time. Overheads: 5% Control Channels; 10% Guard Time; 20% Others

techniques. For example, the German CD 900 digital cellular system employs WB-TDMA techniques [5.7, 5.20, 5.21], with a frame structure shown in Figure 5.6 and a typical value for  $\eta_T$  for WB-TDMA of around 0.65. Most proposed cellular systems for Europe employ NB-TDMA techniques [5.8]. The GSM digital cellular system which was chosen for Europe [5.22], has the frame structure shown in Figure 5.7.

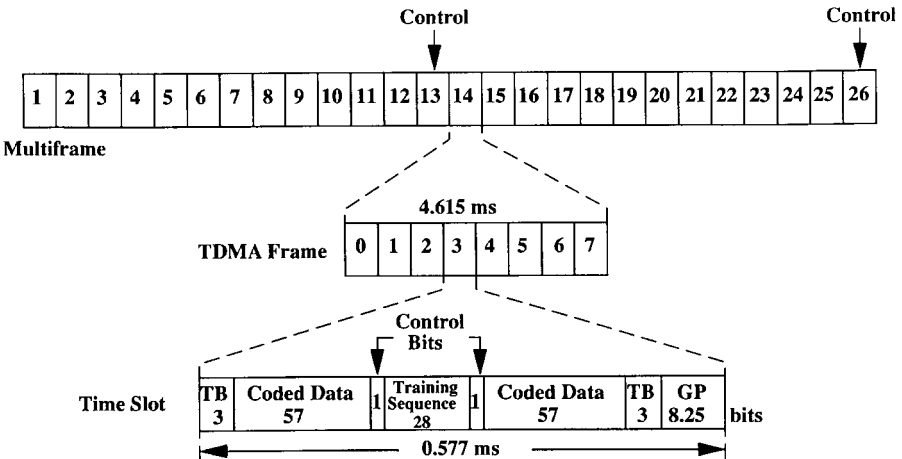

**Figure 5.7** Channel and Time Slot Organization for the GSM Cellular System. TB, Tail Bits; GP, Guard Period. Overheads: 7.7% Control Channels; 4.8% Guard Period; 20% Others

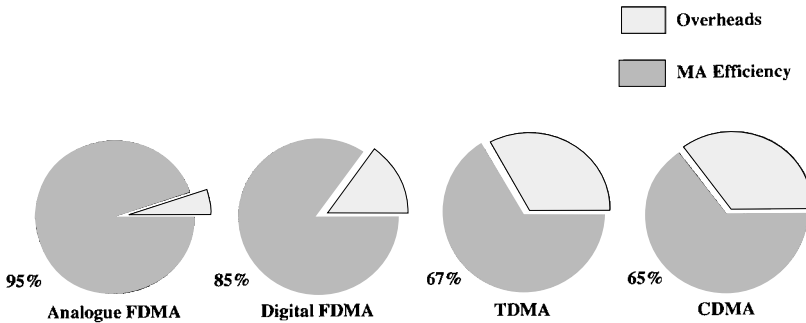

Figure 5.8 Typical Values of Multiple Access Efficiency Factors

A typical value of  $\eta_T$  is around 0.67, error correction code being considered as part of the channel spacing  $B_c$ .

Another digital cellular system proposed for North America shows a multiple access efficiency factor of 0.67 when using NB-TDMA techniques and 0.85 when employing a digital FDMA technique [5.18]. Data for a pure CDMA cellular system are unavailable at the time of writing this book. Nevertheless,  $\eta_T$  for CDMA is expected to be around 0.68. Figure 5.8 shows typical values of  $\eta_T$  for various multiple access techniques.

## REFERENCES

- [5.1] Schwartz, J. W., Aein, J. M. and Kaiser, J., 1966 Modulation Techniques for Multiple Access to a Hard-Limiting Satellite Repeater *Pro IEEE*, **54** May pp. 763–77
- [5.2] Muilwijk, D., 1973 Comparison and Optimization of Multiplexing and Modulation Methods for a Group of Networks *Philips Res. Rep* **28** pp. 347–76
- [5.3] Miya, K., 1982 *Satellite Communications Technology* Second Printing, KDD Engineering and Consulting, Inc., Tokyo
- [5.4] Rappaport, S. S., 1979 Demand Assigned Multiple Access Systems Using Collision Type Request Channels: Traffic Capacity Comparisons *IEEE Trans. Commun* **COM-27** September pp. 1325–31
- [5.5] Scales, W. C., 1980 Potential Use of Spread Spectrum Techniques in Non-Government Applications Aegean Park Press, USA Laguna Hills, California
- [5.6] Dixon, R. C., 1984 *Spread Spectrum Systems* Second Edition, John Wiley & Sons, New York
- [5.7] Eckert, K. D., 1987 Conception and Performance of the Cellular Digital Mobile Radio Communication System CD 900 37th *IEEE Vehicular Technology Conference, Tampa, Florida, 1–3 June 1987* pp. 369–77

- [5.8] Maloberti, A., 1987 Definition of the Radio Subsystem for the GSM Pan-European Digital Mobile Communications System *Proc. International Conference on Digital Land Mobile Radio Communications, Venice, 30 June–3 July 1987* pp. 37–47
- [5.9] Haug, T., 1987 CEPT Activities on a Pan-European Mobile Communication System *Proc. International Conference on Digital Land Mobile Radio Communications, Venice, 30 June–3 July 1987* pp. 1–6
- [5.10] Cooper, G. R. and Nettleton, R. W., 1978 A Spread-Spectrum Technique for High-Capacity Mobile Communications *IEEE Trans. Veh. Technol.* **VT-27** (4) November pp. 264–75
- [5.11] Dornstetter, J. and Verhulst, D., 1987 Cellular Efficiency with Slow Frequency Hopping: Analysis of the Digital SFH 900 Mobile System *IEEE J. Sel. Areas Commun.* **SAC-5**, (5) June pp. 835–48
- [5.12] Kattermole, K. W., 1986 Mathematical Foundations for Communication Engineering *Statistical Analysis and Finite Structures* Vol. 2, Pentech Press, London
- [5.13] Muilwijk, D., 1970 Vergelijking en Optimalisering van Multipelings en Modulatiemethoden voor Enkele Soorten Radionetten *Master's Thesis* The Technical University of Delft, Holland (In Dutch) Reference [5.2] is the English abridged version
- [5.14] Yue, O. -C., 1983 Spread Spectrum Mobile Radio, 1977–1982 *IEEE Trans. Veh. Technol.* **VT-32**, (1) February pp. 98–105
- [5.15] Maseng, T., 1987 On Selection of System Bit-Rate in the Mobile Multipath Channel *IEEE Trans. on Veh. Technol.* **VT-36**, (2) May pp. 51–4
- [5.16] Dechambre, M. and Levy, A. J., 1987 Limits of Data Rates in the Urban Mobile Channel *37<sup>th</sup> IEEE Vehicular Technology Conference, Tampa, Florida, 1–3 June 1987* pp. 541–6
- [5.17] CCIR, 1986 *Report 742–2, XVI Plenary Assembly, Dubrovnik* Vol. VIII-1, International Telecommunications Union pp. 130–48
- [5.18] Lev, V., 1988 *Motorola's View on the Future of Cellular Radio in North America* Report Presented to EIA, TR 45.3, 12 May 1988
- [5.19] NEC Corporation, Japan 1988 *Digital Cellular System* EIA Technical Subcommittee, TR 45.3, Digital Cellular Standards, 11–13 May 1988, Washington DC
- [5.20] Robert, P. and Treillard, P., 1986 Wideband Time Division Multiple Access Mobile Telephone Systems Offer Improved Access Capabilities Compared to Conventional Systems. An Important Step Towards ISDN *Second Nordic Seminar on Digital Land Mobile Radio Communications, 14–16 October 1986* pp. 166–72
- [5.21] Jiang, T., 1987 A Comparison Between the Three Mobile Digital Communication Systems, *37<sup>th</sup> IEEE Vehicular Technology Conference, Tampa, Florida 1–3 June 1987* pp. 359–62
- [5.22] Balston, D. M., 1989 Pan-European Cellular Radio: or 1991 and All That, *Electron. Commun. Eng. J.*, January/February pp. 7–13

# 6

## **Overall Spectral Efficiency of Cellular Systems – Evaluation**

### **6.1 INTRODUCTION**

So far we have established a criterion by which the modulation efficiency of analogue and digital modulation techniques can be evaluated within a cellular system. The spectral efficiency of various multiple access techniques in a cellular environment was also developed. We are now in a position to evaluate the spectral efficiency of cellular land mobile radio systems by combining these results.

In this chapter an expression for the overall spectral efficiency of a cellular system is found by combining the spectral efficiency of the modulation and multiple access techniques employed. Some remarks on how the method is applied for various systems are given. The formula for spectral efficiency is then used to predict the effect of bandwidth expansion, characteristic to some systems, on the spectral efficiency. This is achieved by using some examples of systems employing bandwidth expansion and comparing them to a SSB system. An alternative spectral efficiency measure in terms of Erlangs/MHz/km<sup>2</sup> is mathematically interpreted. This measure reflects the quality in terms of the grade of service, which depends on the model used to describe the traffic in the system. Finally, the spectral efficiencies of some existing and proposed cellular systems are assessed using the new method and the results are presented.

### **6.2 OVERALL SPECTRAL EFFICIENCY OF CELLULAR SYSTEMS**

The overall spectral efficiency of a cellular land mobile radio system employing a particular modulation technique of spectral efficiency  $\eta_M$

Channels/MHz/km<sup>2</sup> and a multiple access technique of spectral efficiency  $\eta_T$  is given by:

$$\eta_C = \eta_M \eta_T. \quad (6.1)$$

In Equation (6.1),  $\eta_T$  represents the fraction or percentage of the total time-frequency domain dedicated for voice transmission and  $\eta_M$  gives the efficiency by which a certain modulation technique utilizes the spectrum. Also, since  $\eta_M$  is in Channels/MHz/km<sup>2</sup> and  $\eta_T$  is dimensionless, the overall spectral efficiency  $\eta_C$  is given in terms of Channels/MHz/km<sup>2</sup>.

Using the general expression for  $\eta_M$ , developed in Chapter 3 (Equation (3.361)),  $\eta_C$  becomes:

$$\eta_C = \frac{\eta_T}{B_c N_c A} \quad (6.2)$$

If the geometrical co-channel interference model with six interferers is adopted,  $\eta_C$  becomes:

$$\eta_C = \frac{3\eta_T}{B_c (6a)^{2/\alpha} A}. \quad (6.3)$$

For two competing cellular systems  $x$  and  $y$ , the relative spectral efficiency  $\eta_R$  is given by:

$$\eta_R = \frac{(\eta_C)_x}{(\eta_C)_y}. \quad (6.4)$$

Using Equation (6.3) and assuming equal cell areas for both cellular systems, the relative spectral efficiency can be written as:

$$\eta_R = \frac{(B_c)_y (a_y)^{2/\alpha} (\eta_T)_x}{(B_c)_x (a_x)^{2/\alpha} (\eta_T)_y} \quad (6.5)$$

where  $\eta_R$  is dimensionless.

### 6.2.1 Calculation of the Channel Spacing for Various Cellular Systems

For analogue cellular systems employing FDMA, the allocated bandwidth is shared by the users in the frequency domain and hence the calculation of the channel spacing  $B_c$  is straightforward. Nevertheless,



in cellular systems which employ TDMA, the allocated bandwidth is shared by the users in the time domain. In this case, the channel spacing  $B_c$  can be calculated by considering the number of time slots or 'time channels' within a given frequency band. Hence,  $B_c$  is simply obtained by dividing the allocated bandwidth by the number of time channels accommodated by the system. In practical systems, this is specified by giving the number of time channels per carrier, where the carrier spacing is known [6.1]. The above procedure is equally applicable to narrowband and wideband TDMA. Similarly, for CDMA cellular systems, the channel spacing  $B_c$  is obtained by dividing the allocated bandwidth by the number of simultaneous users in the system.

It is sometimes difficult to separate the modulation efficiency from the multiple access efficiency, in particular for CDMA systems and whenever the parameters necessary to evaluate the multiple access efficiency are not available. In such cases, it is possible to combine the multiple access efficiency with the modulation efficiency and Equation (6.2) can be re-written as follows:

$$\eta_C = \frac{1}{(B_c/\eta_T)N_cA} \quad (6.6)$$

$$\eta_C = \frac{1}{B_{c,T}N_cA}$$

where  $B_{c,T}$  is the effective channel spacing as a result of combining the multiple access efficiency and the modulation efficiency.

For  $\eta_T < 1$ ,  $B_{c,T} > B_c$ . In this case,  $B_{c,T}$  is obtained by dividing the allocated bandwidth by the maximum number of users that can access the system simultaneously.

### 6.3 EFFECT OF BANDWIDTH EXPANSION ON SPECTRAL EFFICIENCY

The radio spectrum is a finite resource, and it is important that it is exploited efficiently by all users. A wide variety of modulation and multiple access techniques are offered as a solution to spectral congestion in the cellular land mobile radio environment. In general, cellular systems can be classified as either narrowband or wideband systems, and advocates of each claim a superior spectral efficiency over the other. Narrowband systems use the smallest possible channel spacing to economize on spectrum in order to achieve a high spectral

efficiency. On the other hand, wideband systems deliberately expand the channel spacing beyond the baseband in order to attain a better immunity against co-channel interference, thus leading to a smaller re-use distance and hence achieving a higher spectral efficiency. Equation (6.3) shows that the spectral efficiency is inversely proportional to the channel spacing. Hence, the spectral efficiency of a cellular system can be increased by using the narrowest possible channel spacing – an argument for using narrowband cellular systems. Conversely, Equation (6.3) shows that the spectral efficiency is inversely proportional to some power  $2/\alpha$  of the protection ratio, where  $3 < \alpha < 4$ . Expanding the channel spacing can actually reduce the protection ratio needed for a given voice quality and hence increase the spectral efficiency – an argument in favour of wideband cellular systems. It is obvious that a trade off between channel spacing and protection ratio is needed in order to arrive at the highest possible spectral efficiency.

The effect of bandwidth expansion, characteristic of wideband systems, on the spectral efficiency is examined within the cellular environment. Our criterion is to consider the improvement in the signal to noise ratio as a result of using a particular modulation technique, when the baseband channel spacing is expanded by a factor of  $x$ , from  $B_b$  to  $B_c = xB_b$ . The improvement in the signal to noise ratio results in a smaller protection ratio. The advantage of reducing the protection ratio combined with the resulting expanded channel spacing is compared to that dictated by Equation (6.3), hence deducing whether or not such an expansion is spectrally justifiable. The following systems are considered: spread spectrum, WBFM, AM and DSB. The Shannon model is considered as an ideal system and SSB is taken as a reference where bandwidth expansion is not employed.

### 6.3.1 Six-Interferer Cellular Model

The mathematical relation (Equation (6.3)) between the channel spacing  $B_c$  and the protection ratio 'a' dictates that an expansion in the channel spacing by  $x$  requires an improvement in the protection ratio by a factor of  $x^{\alpha/2}$ , in order for the spectral efficiency to remain unchanged. Hence, within a cellular environment, any modulation technique which employs a bandwidth expansion of  $x$  times requires an improvement in the protection ratio by at least  $x^{\alpha/2}$  times, for such a bandwidth expansion to be spectrally feasible. In decibels, the required improvement in the protection ratio is:

$$5\alpha \log(x). \quad (6.7)$$

For  $\alpha = 4$  the required improvement is:

$$20 \log(x). \quad (6.8)$$

Thus, a 6 dB improvement in the protection ratio is required per doubling of the bandwidth.

### 6.3.2 Spread Spectrum

In spread spectrum systems, the baseband bandwidth is expanded (spread) in order to gain in terms of signal to noise ratio. Figure 6.1 shows what happens to the signal after spreading by  $x$  times, where  $x \gg 1$ .

To quantify this, let  $S$  = signal power in watts and  $\eta/2$  = white noise in W/Hz.

Before spreading:

$$\frac{S}{N} = \frac{S}{\eta B_b} \quad (6.9)$$

or

$$\frac{S}{N} = 10 \log \left( \frac{S}{\eta B_b} \right) \text{dB}. \quad (6.10)$$

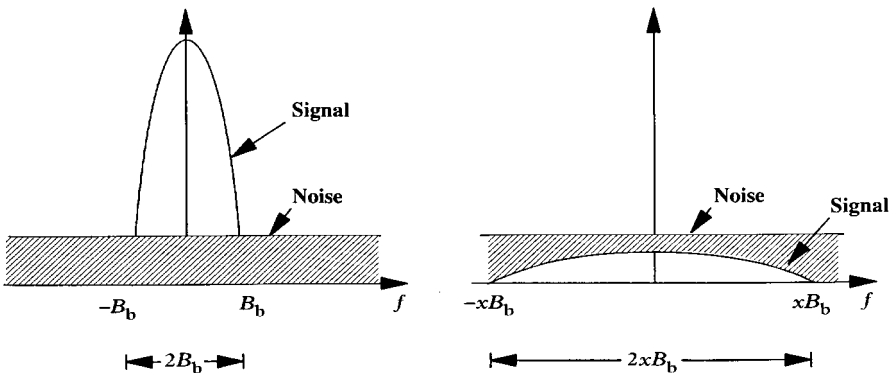

Figure 6.1 Bandwidth Expansion Using Spread Spectrum

After spreading:

Replacing  $B_b$  with  $B_c = xB_b$ :

$$\frac{S}{N} = \frac{S}{(\eta x B_b)} \quad (6.11)$$

$$\therefore \frac{S}{N} = 10 \log \left( \frac{S}{\eta B_b} \right) - 10 \log (x) \text{ dB} \quad (6.12)$$

Equation (6.12) shows that expanding the bandwidth by a factor of  $x$  using spread spectrum techniques results in a signal to noise improvement of  $10 \log (x)$  (i.e. 3 dB per doubling of the bandwidth). This is less than the  $20 \log (x)$  improvement dictated by the six-interferer cellular model. Hence, expanding the channel spacing using spread spectrum techniques is not spectrally justifiable in a cellular environment. Use of a spread spectrum is feasible for  $\alpha = 2$ , which is the case in free-space communication.

### 6.3.3 Wideband Frequency Modulation

In WBFM systems, bandwidth is traded for a better signal to noise ratio. Using a wider bandwidth will achieve the same voice quality at a lower signal to noise ratio. The signal to noise ratio of a FM signal after demodulation is given by Equation (3.58) in Chapter 3:

$$\frac{S}{N} = 3\beta^2 \gamma P_m \quad (6.13)$$

where  $\gamma$  is the signal to noise ratio before bandwidth expansion. For WBFM,  $\beta \gg 1$  and  $B_T = 2\beta f_m$ . For this purpose,  $B_T = B_c$ ,  $f_m = B_b$  and  $B_c = xB_b$ . Also,  $P_m = 1/2$ , for a sinewave message signal.

$$\frac{S}{N} = \left( \frac{3}{8} \right) x^2 \gamma \quad (6.14)$$

Or in decibels:

$$\frac{S}{N} = 20 \log (x) - 4.3 + \gamma_{\text{dB}} \quad (6.15)$$

assuming that  $\gamma$  is so high that the discriminator is working in its linear region (above threshold). Equation (6.15) shows that expanding the bandwidth  $x$  times using WBFM results in a signal to noise

advantage of  $20 \log(x) - 4.3$  dB. However, this is less than the  $20 \log(x)$  dB improvement dictated by the six-interferer cellular model. Hence, expanding the channel spacing using WBFM may not be spectrally efficient within a cellular environment. Equating  $20 \log(x) - 4.3$  and  $5\alpha \log(x)$ , it can be shown that WBFM is spectrally feasible for values of  $\alpha$  less than three (e.g.  $x = 7.24$  at  $\alpha = 3$ ).

### 6.3.4 The Shannon Limit

Using the Shannon model to represent an ideal communication system, the effect of bandwidth expansion on the spectral efficiency within a cellular system can be tested. According to Shannon's theorem the channel capacity  $C$  in bps is given by:

$$C = B \log_2 [1 + (S/N)] \quad (6.16)$$

where  $B$  is the system bandwidth in Hertz.

According to Shannon, it is not possible by any encoding method to send at a higher rate and have an arbitrary low-frequency error. For our purpose, we need to examine the effect of bandwidth expansion on the system's signal to noise ratio. According to Equation (6.16), the same information can be sent using a baseband channel spacing  $B_b$  and a corresponding signal to noise ratio  $\gamma$  – or using a much wider bandwidth  $B_c = xB_b$  but a lower signal to noise ratio  $S/N$ . Equating the two cases:

$$\begin{aligned} B_b \log_2 (1 + \gamma) &= B_c \log_2 [1 + (S/N)] \\ \therefore B_b \log_2 (1 + \gamma) &= xB_b \log_2 [1 + (S/N)]. \end{aligned}$$

Hence:

$$(1 + \gamma) = \left[1 + \left(\frac{S}{N}\right)\right]^x \quad (6.17)$$

For  $\gamma \gg 1$  and  $S/N \gg 1$ :

$$\frac{S}{N} = \gamma^{1/x} \quad (6.18)$$

Or in decibels:

$$\frac{S}{N} = \left(\frac{1}{x}\right) \gamma_{\text{dB}} \quad (6.19)$$

Equation (6.19) shows that expanding the bandwidth by a factor of  $x$  using an ideal communication system results in reducing the required signal to noise requirement  $x$  times, when  $S/N$  is expressed in dB. In other words, doubling the bandwidth will result in halving the signal to noise ratio, expressed in dB.

**6.3.5 Double-Sideband, Amplitude and Single-Sideband Modulation**

DSB modulation and AM systems do not employ bandwidth expansion. Nevertheless, they both use twice the bandwidth of that of a baseband message signal with no advantage in terms of the signal to noise ratio. On the contrary, an AM system shows a signal to noise deterioration of about 5 dB, compared with baseband transmission (see Table 3.1 in Chapter 3).

In theory, SSB systems use the same bandwidth and have the same signal to noise ratio as a baseband message signal.

**6.3.6 Comparison of Bandwidth Expansion Methods**

Table 6.1 shows a comparison of various modulation systems employing bandwidth expansion. The six-interferer model is included as a reference to judge the spectral viability of bandwidth expansion employed by various systems. It is obvious that employing bandwidth expansion using spread spectrum and WBFM is not justifiable within a cellular environment. This is because the protection ratio advantage gained as a result of bandwidth expansion is less than that dictated by the cellular model, hence, an inferior spectral efficiency is the outcome. The same applies to DSB and AM systems.

**Table 6.1** Effect of Bandwidth Expansion on Modulation Efficiency

Modulation System	Bandwidth Expansion	$S/N$	Protection Ratio Advantage (dB)
Cellular, Six-Interferer Model	$x$	$x^2\gamma, \alpha = 4$	$20 \log(x)$
Shannon–Hartley	$x$	$\gamma^x$	$xa_{dB}$
Spread Spectrum	$x \gg 1$	$x\gamma$	$10 \log(x)$
WBFM	$x \gg 1$	$\frac{3}{8}x^2\gamma$	$20 \log(x) - 4.3$
DSB	$x = 2$	$\gamma$	—
AM	$x = 2$	$\gamma/3$	-4.8
SSB (Baseband)	$x = 1$	$\gamma$	—

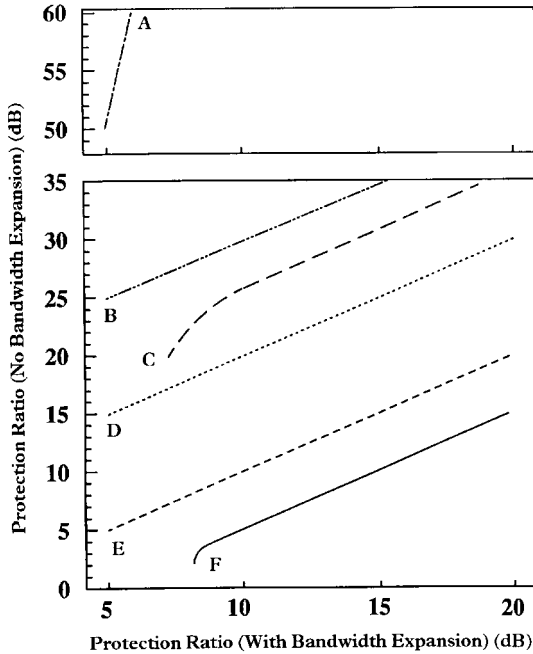

**Figure 6.2** Effect of Bandwidth Expansion on Protection Ratio. A, Shannon Model  $x = 10$ ; B, Cellular Model  $x = 10$ ; C, WBFM  $x = 10$ ; D, Spread Spectrum  $x = 10$ ; E, SSB  $x = 1$  and DSB  $x = 2$ ; F, AM  $x = 2$

Only the ideal system predicted by Shannon shows a considerable increase in the spectral efficiency as a result of bandwidth expansion. The SSB system shows an interesting result, since it is a special case of the ideal system when no expansion is employed (i.e.  $x = 1$ ).

Figure 6.2 shows a graphical representation of the result of bandwidth expansion on the protection ratio for various modulation systems, for  $x = 10$ . The six-interferer cellular model is included as a reference, i.e. systems which fall below the cellular model will have a spectral efficiency disadvantage by employing bandwidth expansion. Such systems include spread spectrum and WBFM systems. Only the ideal system predicted by Shannon may benefit from bandwidth expansion as far as spectral efficiency is concerned. Other systems which do not employ bandwidth expansion such as DSB, AM and SSB are also included in Figure 6.2. SSB uses the minimum bandwidth possible (i.e. baseband bandwidth) with no penalties in terms of signal to noise ratio and hence is spectrally more efficient than DSB and AM systems. Evaluation of the spectral efficiency of practical cellular systems will test the above results.

## 6.4 POWER–BANDWIDTH EXCHANGE IN DIGITAL SYSTEMS AND SPECTRAL EFFICIENCY

$M$ -ary digital modulation schemes were introduced in Chapter Four as an extension to the basic digital modulation techniques.  $M$ -ary digital modulation schemes are often used whenever the bandwidth needs to be conserved at the expense of power and vice versa. In this section, the effect of conserving bandwidth on the spectral efficiency within cellular systems is tested. The same criterion as before will be applied. Namely, an  $M$ -ary scheme which employs a bandwidth compression of  $x$  times is considered spectrally efficient if no more than  $20 \log(x)$  dB deterioration in the  $S/N$  or protection ratio is caused, that is 6 dB per halving of the bandwidth. The objective protection ratio values for various digital modulation techniques shown in Table 4.3 will be used.

### 6.4.1 Digital AM Techniques

From Table 4.3 it can be seen that using QAM instead of coherent ASK can theoretically double the modulation speed with no change in the objective protection ratio, hence leading to a more spectrally efficient digital cellular system. However, moving from QAM to 16-QAM will result in a loss of spectral efficiency. This is because the objective protection ratio drops by about 10 dB, while a decrease by only  $20 \log(3/1.7) = 4.9$  dB is allowed to maintain the spectral efficiency. In this respect, QAM is the most spectrally efficient AM digital scheme amongst those shown in the table.

### 6.4.2 Digital FM Techniques

Using the same argument above, it is spectrally feasible to move from FSK to MSK. MSK can be shown to be the most efficient FM digital scheme amongst those shown in the table.

### 6.4.3 Digital PM Techniques

Considering the practical modulation speeds and the objective protection ratios shown in Table 4.3, the spectral efficiency increases when moving from BPSK to QPSK. However, moving to 8-PSK and 16-PSK will result in a lower spectral efficiency.



#### 6.4.4 Hybrid AM/PM Digital Techniques

APK is an example of this category. Table 4.3 shows that moving from 4-APK to 8-APK does not in fact increase the spectral efficiency. A loss in spectral efficiency will result if 16-APK is used instead of 8-APK. In this category 4-APK is, spectrally, the optimum scheme to employ.

### 6.5 AN ALTERNATIVE SPECTRAL EFFICIENCY MEASURE: ERLANGS/MHZ/KM<sup>2</sup>

An alternative measure of spectral efficiency within cellular systems can be made in terms of Erlangs/MHz/km<sup>2</sup>. Following the definition of an Erlang as the quantity of traffic on a voice channel or a group of channels per unit time and using Equation (3.60) developed in Chapter 3:

$$\text{spectral efficiency in (Erlangs/MHz/km}^2\text{)} = \left[ \frac{\text{traffic carried by } (B_t/B_c) \text{ channels}}{B_t N_c A} \right] \quad (6.20)$$

It is more accurate to treat the traffic in each cell in the system independently. This resembles practical systems where each cell is allocated a number of voice channels, usually  $(B_t/B_c)/N_c$ , of the total channels available to the cellular system. The base station will then handle the traffic in each cell as an independent system. Also, uniform traffic can be assumed within each cell. Hence:

$$\text{spectral efficiency in (Erlangs/MHz/km}^2\text{)} = \left[ \frac{\text{traffic carried by } [(B_t/B_c)/N_c] \text{ channels}}{B_t A} \right] \quad (6.21)$$

Furthermore, the multiple access efficiency  $\eta_T$  can be included in the following way:

$$\eta_E = \frac{\text{traffic carried by } [(B_t/B_c)\eta_T/N_c] \text{ channels}}{B_t A} \quad (6.22)$$

where  $\eta_E$  is the overall spectral efficiency measured in Erlangs/MHz/km<sup>2</sup>.

Basically, there are two models by which the amount of traffic available to a cell in the system can be calculated.

(a) *The 'pure loss' or blocking system model* in which blocked calls are cleared (BCC). That is to say, if a call arises when all channels are busy, the call is immediately cleared with zero holding time. In such systems, the traffic which can be carried by a group of channels will depend on the so-called blocking probability of a call being blocked or lost when a voice channel is not available at the time of calling. This model is best described by the Erlang-B distribution which is widely used in traffic theory [6.2, 6.3 & 6.4]. For various values of the blocking probability, the amount of traffic on a given number of channels can be tabulated (see Table B.1 in Appendix B).

(b) *The queuing system model* in which blocked calls are delayed (BCD). In this model, a call arising when all channels are busy can wait until a voice channel becomes free. The Erlang-C distribution is a good representation of this model [6.2, 6.3]. It gives the probability of a delay greater than ' $t$ ' seconds in terms of the number of channels available to the system.

In general, traffic models are very much dependent upon the behaviour of users in the system and hence, the choice of traffic model for cellular systems must follow a detailed study of such behaviour within the mobile environment. Cellular systems are more closely described by the pure loss model. Using a queuing system model may require more control channels to accommodate the queue, which can lower the multiple access efficiency of the cellular system. Further, given the same number of traffic channels  $n$  and the same value of blocking, it can be shown that the Erlang-B model offers more Erlangs than the Erlang-C model. It follows that employing a queuing system is unlikely to improve the spectral efficiency of cellular systems and for this reason a pure loss model is favoured.

The following points can be noted from Equation (6.22):

(a) The spectral efficiency  $\eta_E$  in Erlangs/MHz/km<sup>2</sup> is influenced by the quality of the cellular system in terms of the grade of service with the blocking probability  $P_B$  or waiting time as a parameter, depending on the model adopted.

(b) The voice quality is represented by the value of  $N_c$ , since  $N_c$  is a function of the protection ratio of the modulation system employed.

(c) The spectral efficiency  $\eta_E$  in Erlangs/MHz/km<sup>2</sup> depends on the total bandwidth  $B_t$  allocated to the system, unlike the previous measure  $\eta_C$  in Channels/MHz/km<sup>2</sup>, which is independent of  $B_t$ . This is due to the non-linear relationship between the number of traffic channels available to the cell and the amount of traffic in Erlangs which can be carried by the channels.

(d) The capacity of a cellular systems  $\eta_U$  in terms of Users/MHz/km<sup>2</sup> can be derived given the spectral efficiency in Erlangs/MHz/km<sup>2</sup> and the average traffic per user in the system (e.g. 0.05 Erlangs/User in the busy hour).

Equation (6.22) will be used to calculate the spectral efficiency  $\eta_E$  in Erlangs/MHz/km<sup>2</sup> considering the availability of radio links between one mobile party and the nearest base station. Blocking that is internal to the land system connecting base stations will be ignored. This is justifiable since the spectral efficiency of the radio part of the system is the prime concern and the radio channels are the limiting factor in the system. However, knowing the blocking probability between the mobile party and the serving base station and the blocking probability between the base station and the land system, the calculation of the overall grade of service is trivial. Furthermore, in a cellular system with small cells, the chance that the mobiles of both the calling and called parties are in the same cell is very small. If this case is ignored, then the blocking probability  $P'_B$  of a mobile-to-mobile call is:

$$P'_B = 1 - (1 - P_B)^2 \quad (6.23)$$

$$P'_B \approx 2P_B \quad \text{for } P_B \ll 1 \quad (6.24)$$

where  $P_B$  is the blocking probability of one mobile party to a call.

Some statistics show that mobile-to-mobile calls form only 2% of the total traffic during the busy hour compared with 68% for mobile-to-land calls and 30% for land-to-mobile calls (for the Nordic Mobile Telephone System [6.5]). It follows that, ignoring blocking which is internal to the land system, the blocking probability  $P_B$  reflects the grade of service within cellular systems except for the small proportion of mobile-to-mobile calls in different cells which will experience a grade of service of  $2P_B$ .

## 6.6 EVALUATION OF SOME EXISTING AND PROPOSED CELLULAR SYSTEMS

It is important to begin by evaluating the spectral efficiency of various analogue and digital modulation techniques for two reasons. First, the modulation technique employed is the key element that decides the efficiency and hence the quality of any cellular system. Second, the effect of bandwidth expansion, discussed earlier, can be put to the test.

### 6.6.1 Modulation Efficiency of Analogue and Digital Techniques

Table 6.2 shows a comparison of the spectral efficiency of some analogue modulation techniques for  $\alpha = 3, 3.5$  and  $4$ . The subjective protection ratios are deduced from [6.6], such that a quality similar to 25 kHz FM is achieved. Also, a radius of  $R = 1$  km ( $A \approx 3$  km<sup>2</sup>), is assumed and all values of  $N_c$  are assumed possible. It can be seen that SSB offers the highest spectral efficiency which is about 3.8 times those of a conventional 25 kHz FM technique. AM modulation techniques are the least efficient as expected, although the protection ratio used is somewhat optimistic. Furthermore, amongst all the FM techniques, that at 12.5 kHz is the most efficient. This supports the findings in section 6.3.3, that expanding the channel spacing using a WBFM technique is not spectrally efficient within a cellular environment. These results are also presented graphically in Figure 6.3.

In a similar fashion and with the same assumptions, a representative set of digital modulation techniques are compared in terms of their spectral efficiency in Table 6.3. Objective protection ratios are used since there is a lack of subjectively measured protection ratios, in particular, for digital modulation techniques. As predicted in section

**Table 6.2** Spectral Efficiency of some Analogue Modulation Techniques

	$B_c$ (kHz)	$a$ (dB)	$\eta_M$ (Channels/MHz/km <sup>2</sup> )		
			$\alpha = 3$	$\alpha = 3.5$	$\alpha = 4$
FM	25	18	0.76	1.35	2.06
FM	30	17	0.74	1.28	1.92
FM	12.5	22	0.83	1.59	2.59
AM	12.5	25	0.52	1.07	1.84
SSB	5	20	2.81	5.17	8.16

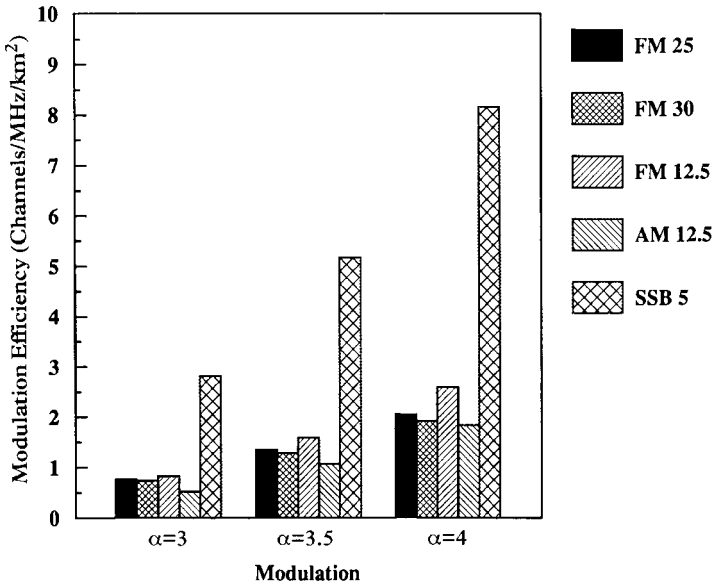

Figure 6.3 Spectral Efficiency of some Analogue Modulation Techniques

6.4, QAM is the most spectrally efficient AM digital scheme, MSK is the most efficient FM digital scheme and QPSK is the most efficient PM digital scheme. 4-APK is spectrally the optimum scheme to employ, not only amongst the hybrid AM/PM techniques but also compared with all other techniques shown in the table. This is closely followed by QPSK, then MSK and QAM. It can be seen that 4-APK can offer about 3.8 times the spectral efficiency of a conventional 25 kHz FM analogue technique. Again, the results are also presented graphically in Figure 6.4.

**6.6.2 Spectral Efficiency of Cellular Systems**

The first generation cellular systems are predominantly analogue FM/FDMA based systems. However, all second-generation cellular systems in Europe, North America and Japan are digital, perhaps because ‘going digital’ seems to be the natural move, following other systems such as satellite, switching and microwave systems. A representative set of spectral efficiency values for both first-and second-generation cellular systems will be evaluated for α = 3, 3.5 and 4. As before, a cell radius of 1 km (A ≈ 3 km<sup>2</sup>) is assumed and all values of N<sub>c</sub> are

**Table 6.3** Modulation Efficiency of some Digital Modulation Techniques

	Digital Modulation and Detection	Equivalent $B_c$ (kHz)	Objective Protection Ratio $a$ (dB)	$\eta_M$ (Ch/MHz/km <sup>2</sup> )		
				$\alpha = 3$	$\alpha = 3.5$	$\alpha = 4$
AM	ASK-Envelope	> 20	19	0.82	1.47	2.29
	ASK-C	20	17	1.11	1.92	2.88
	QAM	9.4	17	2.37	4.08	6.13
	QPR	7.1	20.5	1.83	3.41	5.43
	16-QAM	5.3	27.5	0.84	1.82	3.25
FM	FSK ( $h = 1$ )-NC	20	20	0.70	1.29	2.04
	CP-FSK ( $h = 0.7$ )-NC	16	18	1.19	2.10	3.21
	CP-FSK ( $h = 0.7$ )-C	16	13	2.57	4.06	5.71
	MSK ( $h = 0.5$ )-C	8.4	17	2.65	4.57	6.87
PM	MSK ( $h = 0.5$ )-DE	8.4	20	1.67	3.08	4.86
	BPSK-C	20	14	1.77	2.85	4.07
	DE-BPSK	20	17	1.11	1.92	2.88
	DPSK	20	17	1.11	1.92	2.88
	DQPSK	8.9	23	1.00	1.96	3.25
	QPSK	8.4	16.5	2.86	4.88	7.27
	8-PSK	6.2	21.3	1.86	3.51	5.67
	16-PSK	5.5	27	0.87	1.87	3.32
AM/PM	4-APK	> 8	16.5	3.00	5.12	7.64
	8-APK	5.7	19.8	2.54	4.66	7.33
	16-APK	4.8	24	1.58	3.18	5.37

C, Coherent; NC, Non-coherent; DE, Differential Encoding. Data taken from a variety of sources. QAM/APK belong to the same family and should in theory have the same performance.

assumed possible. Furthermore,  $\eta_T, \eta_C, \eta_R$  (relative to 25 kHz FM),  $\eta_E$  and  $\eta_U$  (at 0.05 Erlangs/User) for 2% and 5% blocking probabilities will be evaluated for each system. All cellular systems are assumed to be operating in a 10 MHz frequency band.

A brief description of various first-generation cellular systems and their parameters can be found in [6.7]; their spectral efficiencies are evaluated in Tables 6.4, 6.5 and 6.6 for  $\alpha = 3, 3.5$  and 4 respectively. A proposed 5 kHz ACSSB/FDMA cellular system is included for the sake of comparison. It can be seen that various FM/FDMA cellular systems have more or less the same spectral efficiency, with the 12.5 kHz FM system offering a slight advantage. The ACSSB system can offer up to four times the spectral efficiency of a conventional FM/FDMA system.

Unlike FM/FDMA cellular systems which are mature and well established, digital cellular systems are relatively new to the cellular mobile environment. Moreover, subjectively measured protection

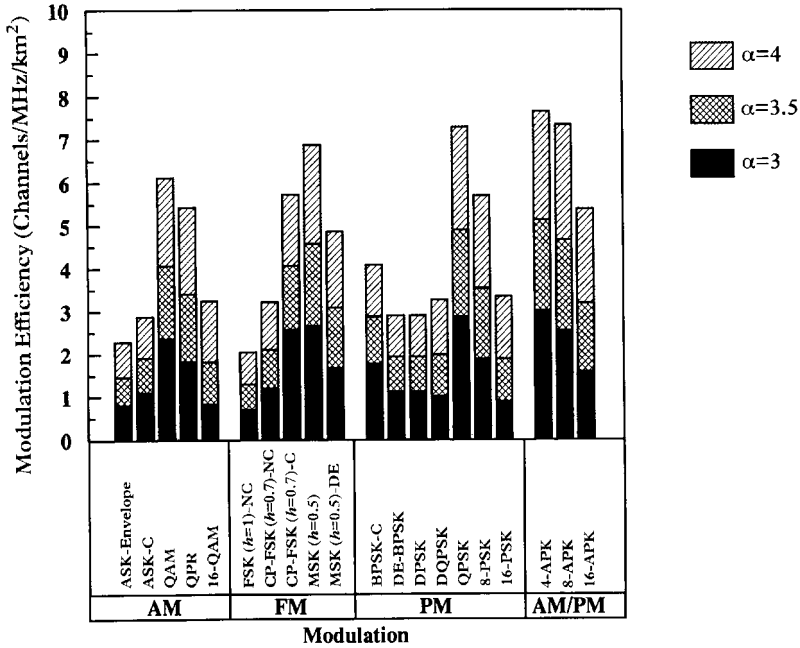

Figure 6.4 Modulation Efficiency of Various Digital Techniques. C, Coherent; NC, Non-coherent; DE, Differential Encoding

ratios for digital cellular systems are generally unavailable and hence one has to resort to objective values (see Table 6.3).

Various proposals for the Pan-European cellular system are described in the literature [6.1, 6.8–6.18] and the system which was finally chosen by Group Spécial Mobile (GSM) is described in [6.19]. Tables 6.7, 6.8 and 6.9 show that most of the proposed systems are spectrally more efficient than the present FM/FDMA systems. The GSM cellular system chosen for Europe can offer 1.6 times the efficiency of a conventional FM/FDMA system at  $\alpha = 4$ , which is not even the most efficient solution offered. Nonetheless, the spectral efficiency of the GSM Pan-European system is expected to double when an 8 kbps toll quality coder becomes available. The spectral efficiency may also be improved further by employing techniques so that lower protection ratios may be used (e.g. diversity reception, error detection and correction coding, etc.). The protection ratio figures presented do not include these techniques.

Proposals for the North American digital cellular system are described in [6.20–6.24] and their spectral efficiencies are evaluated in Tables 6.10, 6.11 and 6.12. The spectrally most promising proposals

Table 6.4 Spectral Efficiency of some First-generation Cellular Systems ( $\alpha = 3$ )

Cellular System	$B_c$ (kHz)	$a$ (dB)	$\eta_T$	$\eta_C$ (Ch/MHz/km <sup>2</sup> )	$\eta_{R\ddagger}$	$\eta_E$ (E/MHz/km <sup>2</sup> )		$\eta_{U\ddagger}$ (Users/MHz/km <sup>2</sup> )	
						$P_B$	2%	5%	$P_B$
TACS (UK) FM/FDMA	25	18–19 (Measured)	0.95	0.73	1.00	0.50	0.57	9.9	11.4
AMPS (USA) FM/FDMA	30	17–18 (Measured)	0.95	0.71	0.97	0.47	0.54	9.4	10.8
NAMT (Japan) FM/FDMA	25	18–19 (Measured)	0.95	0.73	1.00	0.50	0.57	9.9	11.4
NMT-450 (Nordic) FM/FDMA	25	18–19 (Measured)	0.95	0.73	1.00	0.50	0.57	9.9	11.4
NMT-900 (Nordic) FM/FDMA	12.5	22 (Measured)	0.95	0.79	1.08	0.55	0.63	11.1	12.7
C450 (Germany) FM/FDMA	20	20 (Estimated)	0.95	0.67	0.92	0.44	0.51	8.8	10.2
ACSSB/FDMA (Proposed)	5	20 (Measured)	0.95	2.67	3.66	2.29	2.49	45.8	49.9

† Relative to 25 kHz FM.

‡ At 0.05 Erlangs/User.



**Table 6.5** Spectral Efficiency of some First-generation Cellular Systems ( $\alpha = 3.5$ )

Cellular System	$B_c$ (kHz)	$a$ (dB)	$\eta_T$	$\eta_C$ (Ch/MHz/km <sup>2</sup> )	$\eta_E$ (E/MHz/km <sup>2</sup> )		$\eta_{U\dagger}$ (Users/MHz/km <sup>2</sup> )		
					$\eta_R\dagger$	$P_B$	$\eta_R\dagger$	$P_B$	
TACS (UK) FM/FDMA	25	18–19 (Measured)	0.95	1.28	1.00	0.97	1.09	19.4	21.8
AMPS (USA) FM/FDMA	30	17–18 (Measured)	0.95	1.21	0.95	0.91	1.02	18.2	20.4
NAMT (Japan) FM/FDMA	25	18–19 (Measured)	0.95	1.28	1.00	0.95	1.09	19.0	21.8
NIMT-450 (Nordic) FM/FDMA	25	18–19 (Measured)	0.95	1.28	1.00	0.95	1.09	19.0	21.8
NIMT-900 (Nordic) FM/FDMA	12.5	22 (Measured)	0.95	1.51	1.18	1.19	1.32	23.8	26.4
C450 (Germany) FM/FDMA	20	20 (Estimated)	0.95	1.23	0.96	0.94	1.05	18.8	21.1
ACSSB/FDMA (Proposed)	5	20 (Measured)	0.95	4.91	3.84	4.46	4.79	89.2	95.7

† Relative to 25 kHz FM.

‡ At 0.05 Erlangs/User.

Table 6.6 Spectral Efficiency of some First-generation Cellular Systems ( $\alpha = 4$ )

Cellular System	$B_c$ (kHz)	$a$ (dB)	$\eta_T$	$\eta_C$ (Ch/MHz/km <sup>2</sup> )	$\eta_R^\dagger$	$\eta_E$ (E/MHz/km <sup>2</sup> )		$\eta_U^\ddagger$ (Users/MHz/km <sup>2</sup> )	
						$P_B$		$P_B$	
						2%	5%	2%	5%
TACS (UK) FM/FDMA	25	18–19 (Measured)	0.95	1.95	1.00	1.62	1.79	32.4	35.8
AMPS (USA) FM/FDMA	30	17–18 (Measured)	0.95	1.83	0.94	1.50	1.65	30.0	33.0
NAMT (Japan) FM/FDMA	25	18–19 (Measured)	0.95	1.95	1.00	1.62	1.79	32.4	35.8
NMT-450 (Nordic) FM/FDMA	25	18–19 (Measured)	0.95	1.95	1.00	1.62	1.79	32.4	35.8
NMT-900 (Nordic) FM/FDMA	12.5	22 (Measured)	0.95	2.46	1.26	2.10	2.29	42.0	45.8
C450 (Germany) FM/FDMA	20	20 (Estimated)	0.95	1.94	0.99	1.59	1.75	31.9	35.1
ACSSB/FDMA (Proposed)	5	20 (Measured)	0.95	7.76	3.98	7.30	7.76	145.9	155.2

† Relative to 25 kHz FM.

‡ At 0.05 Erlangs/User.

Table 6.7 Spectral Efficiency of Different Proposed Systems for Europe ( $\alpha = 3$ )

Cellular System	$B_c$ (kHz)	$a$ (dB)	$\eta_T$	$\eta_C$ (Ch/MHz/km <sup>2</sup> )	$\eta_R^\dagger$	$\eta_E$ (E/MHz/km <sup>2</sup> )		$\eta_U^\ddagger$ (Users/MHz/km <sup>2</sup> )	
						$P_B$	2%	5%	$P_B$
MATS-D/N	25	17	0.85	0.85	1.16	0.58	0.67	11.7	13.3
GTFM/FDMA									
S900-D	25	13	0.67	1.56	2.14	1.25	1.38	25.0	27.7
4-PSK/NB-TDMA									
MAX II	12.5	19.5	0.67	1.15	1.58	0.85	0.96	17.0	19.1
8-PSK/NB-TDMA									
SFH 900	50	13	0.67	0.78	1.07	0.53	0.60	10.5	12.1
GMSK/NB-TDMA									
MATS-D/W	39	17	0.67	0.54	0.74	0.33	0.38	6.6	7.7
QAM/TDMA&CDMA									
MOBIRA	28	15	0.67	1.03	1.41	0.76	0.86	15.2	17.2
GMSK/NB-TDMA									
DMS 90	30	14	0.67	1.12	1.53	0.85	0.96	17.0	19.1
GMSK/NB-TDMA									
ADPM	25	12	0.67	1.82	2.49	1.50	1.65	29.9	33.0
ADPM/NB-TDMA									
CD 900	72	12	0.65	0.63	0.86	0.41	0.48	8.2	9.5
4-PSK/WB-TDMA									
GSM (Chosen)	25	14§	0.67	1.34	1.84	1.03	1.15	20.7	23.1
GMSK/NB-TDMA									
GMS (Future)	12.5	14§	0.67	2.68	3.67	2.32	2.53	46.4	50.5

† Relative to 25 kHz FM.

‡ At 0.05 Erlangs/User.

§ 9 dB with coding.

Table 6.8 Spectral Efficiency of Different Proposed Systems for Europe ( $\alpha = 3.5$ )

Cellular System	$B_c$ (kHz)	$a$ (dB)	$\eta_T$	$\eta_C$ (Ch/MHz/km <sup>2</sup> )	$\eta_{R\ddagger}$	$\eta_E$ (E/MHz/km <sup>2</sup> )		$\eta_{U\ddagger}$ (Users/MHz/km <sup>2</sup> )	
						$P_B$		$P_B$	
						2%	5%	2%	5%
MATS-D/N GTFM/FDMA	25	17	0.85	1.46	1.14	1.16	1.29	23.1	25.7
S900-D 4FSK/NB-TDMA	25	13	0.67	2.47	1.93	2.10	2.29	41.9	45.8
MAX II 8-PSK/NB-TDMA	12.5	19.5	0.67	2.10	1.64	1.75	1.92	35.0	38.4
SFH 900 GMSK/NB-TDMA	50	13	0.67	1.23	0.96	0.94	1.05	18.8	21.1
MATS-D/W QAM/TDMA&CDMA	39	17	0.67	0.93	0.73	0.67	0.76	13.4	15.2
MOBIRA GMSK/NB-TDMA	28	15	0.67	1.69	1.32	1.37	1.52	27.5	30.3
DMS 90 GMSK/NB-TDMA	30	14	0.67	1.80	1.41	1.47	1.62	29.3	32.3
ADPM ADPM/NB-TDMA	25	12	0.67	2.81	2.20	2.42	2.63	48.3	52.6
CD 900 4-PSK/WB-TDMA	72	12	0.65	0.98	0.77	0.70	0.79	14.0	15.9
GSM (Chosen) GMSK/NB-TDMA	25	14§	0.67	2.16	1.69	1.81	1.99	36.3	39.7
GMS (Future)	12.5	14§	0.67	4.33	3.38	3.91	4.20	78.1	84.1

† Relative to 25 kHz FM.

‡ At 0.05 Erlangs/User.

§ 9 dB with coding.

Table 6.9 Spectral Efficiency of Different Proposed Systems for Europe ( $\alpha = 4$ )

Cellular System	$B_c$ (kHz)	$a$ (dB)	$\eta_T$	$\eta_C$ (Ch/MHz/km <sup>2</sup> )	$\eta_{RT}^\dagger$	$\eta_E$ (E/MHz/km <sup>2</sup> )		$\eta_{U^\ddagger}$ (Users/MHz/km <sup>2</sup> )	
						$P_B$		$P_B$	
						2%	5%	2%	5%
MATS-D/N GTFM/FDMA	25	17	0.85	2.19	1.12	1.84	2.02	36.9	40.4
S900-D 4-PSK/NB-TDMA	25	13	0.67	3.47	1.78	3.06	3.31	61.3	66.2
MAX II 8-PSK/NB-TDMA	12.5	19.5	0.67	3.29	1.69	2.90	3.14	58.0	62.8
SFH 900 GMSK/NB-TDMA	50	13	0.67	1.74	0.89	1.40	1.55	28.1	31.0
MATS-D/W QAM/TDMA&CDMA	39	17	0.67	1.40	0.72	1.09	1.22	21.9	24.4
MOBIRA GMSK/NB-TDMA	28	15	0.67	2.46	1.26	2.10	2.29	41.9	45.8
DMS 90 GMSK/NB-TDMA	30	14	0.67	2.58	1.32	2.20	2.39	43.9	47.9
ADPM ADPM/NB-TDMA	25	12	0.67	3.90	2.00	3.48	3.76	69.7	75.1
CD 900 4-PSK/WB-TDMA	72	12	0.65	1.35	0.69	1.06	1.19	21.3	23.7
GSM (Chosen) GMSK/NB-TDMA	25	14 <sup>§</sup>	0.67	3.10	1.59	2.71	2.94	4.1	58.7
GMS (Future)	12.5	14 <sup>§</sup>	0.67	6.20	3.18	5.74	6.10	114.2	122.7

<sup>†</sup> Relative to 25 kHz FM.

<sup>‡</sup> At 0.05 Erlangs/User.

<sup>§</sup> 9 dB with coding.

**Table 6.10** Spectral Efficiency of some Cellular Systems Proposed for North America ( $\alpha = 3$ )

Cellular System	$B_c$ (kHz)	$a$ (dB)	$\eta_T$	$\eta_C$ (Ch/MHz/km <sup>2</sup> )	$\eta_{R\dagger}$	$\eta_E$ (E/MHz/km <sup>2</sup> )		$\eta_{U\dagger}$ (Users/MHz/km <sup>2</sup> )	
						$P_B$	2%	5%	$P_B$
Ericsson QPSK/NB-TDMA	15	14	0.67	2.24	3.07	1.88	2.05	37.5	41.1
	Present	Expected							
Ericsson QPSK/NB-TDMA	10	14	0.67	3.35	4.59	2.96	3.21	59.3	64.2
	Future	Expected							
Motorola Digital/FDMA	10	17	0.85	2.12	2.90	1.75	1.92	35.0	38.4
	Present								
Motorola Digital/NB-TDMA	10	17	0.63	2.12	2.90	1.75	1.92	35.0	38.4
	Present								
Motorola Digital/FDMA	7.5	17	0.85	2.82	3.86	2.42	2.63	48.3	52.6
	Future								
Motorola Digital/NB-TDMA	7.5	17	0.63	2.82	3.86	2.42	2.63	48.3	52.6
	Future								
Motorola Digital/Hybrid <sup>§</sup>	15	20	0.74	0.89	1.22	0.64	0.73	12.8	14.6
AT&T Bell Labs DQPSK/FDMA	10	15	0.85	2.88	3.95	2.48	2.70	49.7	53.9
		Expected							

<sup>†</sup> Relative to 25 kHz FM.

<sup>‡</sup> At 0.05 Erlangs/User.

<sup>§</sup> NB-TDMA/FDMA.

**Table 6.11** Spectral Efficiency of some Cellular Systems Proposed for North America ( $\alpha = 3.5$ )

Cellular System	$B_c$ (kHz)	$a$ (dB)	$\eta_T$	$\eta_C$ (Ch/MHz/km <sup>2</sup> )	$\eta_{R^\dagger}$	$\eta_E$ (E/MHz/km <sup>2</sup> )		$\eta_{U^\ddagger}$ (Users/MHz/km <sup>2</sup> )	
						$P_B$	$P_B$		
Ericsson	15	14	0.67	3.61	2.82	3.19	3.45	63.8	68.9
QPSK/NB-TDMA	Present	Expected							
Ericsson	10	14	0.67	5.41	4.23	4.95	5.30	99.1	106.1
QPSK/NB-TDMA	Future	Expected							
Motorola	10	17	0.85	3.64	2.84	3.22	3.48	64.5	69.7
Digital/FDMA	Present								
Motorola	10	17	0.63	3.64	2.84	3.22	3.48	64.5	69.7
Digital/NB-TDMA	Present								
Motorola	7.5	17	0.85	4.86	3.80	4.43	4.75	88.6	95.1
Digital/FDMA	Future								
Motorola	7.5	17	0.63	4.86	3.80	4.43	4.75	88.6	95.1
Digital/NB-TDMA	Future								
Motorola	15	20	0.74	1.64	1.28	1.31	1.45	26.2	29.0
Digital/Hybrid <sup>§</sup>									
AT&T Bell Labs	10	15	0.85	4.74	3.70	4.30	4.62	85.9	92.3
DQPSK/FDMA	Expected								

<sup>†</sup> Relative to 25 kHz FM.

<sup>‡</sup> At 0.05 Erlangs/User.

<sup>§</sup> NB-TDMA/FDMA.

**Table 6.12** Spectral Efficiency of some Cellular Systems Proposed for North America ( $\alpha = 4$ )

Cellular System	$B_c$ (kHz)	$a$ (dB)	$\eta_T$	$\eta_C$ (Ch/MHz/km <sup>2</sup> )	$\eta_R^\dagger$	$\eta_E$ (E/MHz/km <sup>2</sup> )		$\eta_{U^\ddagger}$ (Users/MHz/km <sup>2</sup> )	
						$P_B$	$P_B$	$P_B$	$P_B$
						2%	5%	2%	5%
Ericsson QPSK/NB-TDMA	15 Present	14 Expected	0.67	5.16	2.65	4.72	5.03	94.5	100.1
Ericsson QPSK/NB-TDMA	10 Future	14 Expected	0.67	7.74	3.97	7.26	7.73	145.3	154.5
Motorola Digital/FDMA	10 Present	17	0.85	5.48	2.81	5.02	5.37	100.3	107.4
Motorola Digital/NB-TDMA	10 Present	17	0.63	5.48	2.81	5.02	5.37	100.3	107.4
Motorola Digital/FDMA	7.5 Future	17	0.85	7.30	3.74	6.83	7.28	136.7	145.5
Motorola Digital/NB-TDMA	7.5 Future	17	0.63	7.30	3.74	6.83	7.28	136.7	145.5
Motorola Digital/Hybrid <sup>§</sup>	15	20	0.74	2.59	1.33	2.23	2.43	44.5	48.5
AT&T Bell Labs DQPSK/FDMA	10	15 Expected	0.85	6.90	3.54	6.40	6.82	128.1	136.5

<sup>†</sup> Relative to 25 kHz FM.

<sup>‡</sup> At 0.05 Erlangs/User.

<sup>§</sup> NB-TDMA/FDMA.



Table 6.13 Spectral Efficiency of some Cellular Systems Proposed for Japan

Cellular System	$B_c$ (kHz)	$a$ (dB)	$\eta_T$	$\eta_C$ (Ch/MHz/km <sup>2</sup> )	$\eta_{R^\dagger}$	$\eta_E$ (E/MHz/km <sup>2</sup> )		$\eta_{U^\ddagger}$ (Users/MHz/km <sup>2</sup> )	
						$P_B$		$P_B$	
						2%	5%	2%	5%
$\alpha = 3$									
NEC	15.5	12	0.76	2.94	4.03	2.55	2.77	50.9	55.3
$\pi/4$ QPSK/Hybrid <sup>§</sup>		Expected							
NEC	15.5	16.5–18	0.76	1.47	2.01	1.16	1.29	23.1	25.7
$\pi/4$ QPSK/Hybrid <sup>§</sup>		Objective							
Oki Electronic (Tokyo)	10	( $N_c = 7$ )	0.85	4.49	(6.15)	4.07	4.38	81.4	87.5
$\pi/4$ QPSK/SCPC/FDMA									
$\alpha = 3.5$									
NEC	15.5	12	0.76	4.54	3.55	4.10	4.41	82.1	88.2
$\pi/4$ QPSK/Hybrid <sup>§</sup>		Expected							
NEC	15.5	16.5–18	0.76	2.51	1.96	2.13	2.33	42.6	46.5
$\pi/4$ QPSK/Hybrid <sup>§</sup>		Objective							
Oki Electronic (Tokyo)	10	( $N_c = 7$ )	0.85	4.49	(3.51)	4.04	4.38	81.4	87.5
$\pi/4$ QPSK/SCPC/FDMA									
$\alpha = 4$									
NEC	15.5	12	0.76	6.29	3.23	5.84	6.24	116.9	124.7
$\pi/4$ QPSK/Hybrid <sup>§</sup>		Expected							
NEC	15.5	16.5–18	0.76	3.74	1.92	3.32	3.58	66.4	71.7
$\pi/4$ QPSK/Hybrid <sup>§</sup>		Objective							
Oki Electronic (Tokyo)	10	( $N_c = 7$ )	0.85	4.49	(2.30)	4.07	4.38	81.4	87.5
$\pi/4$ QPSK/SCPC/FDMA									

† Relative to 25 kHz FM.

‡ At 0.05 Erlangs/User.

§ NB-TDMA/FDMA.

are based upon QPSK/NB-TDMA (by Ericsson and AT & T Bell Labs). The spectral efficiency of these systems at  $\alpha = 4$  is some 3.5 times that of a conventional FM/FDMA system and even higher spectral efficiencies are expected when lower bit rate toll-quality voice coders become available.

Proposals for the Japanese second-generation cellular system are all based on a  $\pi/4$  shift QPSK digital modulation technique [6.25–6.28], and are evaluated in terms of spectral efficiency in Table 6.13. Compared with conventional FM systems, they can better the existing spectral efficiency at  $\alpha = 4$  more than threefold. This efficiency is also expected to be increased by the use of more efficient voice coders which may become available in the near future.

## REFERENCES

- [6.1] Maloberti, A., 1987 Definition of the Radio Subsystem for the GSM Pan-European Digital Mobile Communications System, *Proc. International Conference on Digital Land Mobile Radio Communications, Venice, 30 June–3 July 1987* pp. 37–47
- [6.2] Hills, M. T., 1984 *Telecommunications Switching Principles* Second Impression, George Allen and Unwin, London
- [6.3] Jakes, W. C., 1974 *Microwave Mobile Communications* John Wiley and Sons, New York
- [6.4] Freeman, R. L., 1985 Reference Manual for Telecommunications Engineering, Wiley-Interscience, New York
- [6.5] Jansson, A., 1984 Experiences of Operation of an Automatic Mobile Telephone System *Proceedings of the XI International Switching Symposium, Florence, Italy, 7–11 May 1984*
- [6.6] Home Office Directorate of Radio Technology, 1982 *Report on Comparative Tests of Modulation Methods for Private Mobile Radio* Home Office, Radio Regulatory Department, UK
- [6.7] CCIR, 1986 *Report 742–2, XVI Plenary Assembly, Dubrovnik* Vol. VIII–1, International Telecommunication Union pp. 127–48
- [6.8] Eckert, K. D., 1987 Conception and Performance of the Cellular Digital Mobile Radio Communication System CD 900 *37th IEEE Vehicular Technology Conference, Tampa, Florida 1–3rd June 1987* pp. 369–77
- [6.9] D’Avella, R., 1986 On the Spectral Efficiency of CD 900, *Second Nordic Seminar on Digital Land Mobile Radio Communications, 14–16 October 1986* pp. 160–3
- [6.10] Robert, P. 1986 and Trellard, P., Wideband Time Division Multiple Access Mobile Telephone Systems Offer Improved Access Capabilities Compared to Conventional Systems. An Important Step Towards ISDN,

- Second Nordic Seminar on Digital Land Mobile Radio Communications, 14–16 October 1986* pp. 166–72
- [6.11] Dornstetter, J. L., 1987 Experimental Results with the SFH 900 *Proc. International Conference on Digital Land Mobile Radio Communications, Venice, 30 June–3 July 1987* pp. 319–25
- [6.12] Swedish Telecom Radio, 1986 'Max' Digital Mobile Radio System *Second Nordic Seminar on Digital Land Mobile Radio Communications, 14–16 October 1986* pp. 109–14
- [6.13] Dornstetter, J. L. and Verhulst, D., 1987 Cellular Efficiency with Slow Frequency Hopping: Analysis of the Digital SFH 900 Mobile System *IEEE J. Sel. Areas Commun. SAC-5* (5) June pp. 835–48
- [6.14] Tietgen, K. H., 1986 Numerical Modulation Methods Applied in the FD/TDMA-System S 900 D, *Second Nordic Seminar on Digital Land Mobile Radio Communications, 14–16 October 1986* pp. 138–41
- [6.15] Eizenhofer, A., *et al.*, MATS-D System Concept *Second Nordic Seminar on Digital Land Mobile Radio Communications, 14–16 October 1986* pp. 146–50
- [6.16] Spicer, J. J., 1987 The Practical Performance of an Experimental Broadband Digital Mobile Radio Technique *Proc. International Conference on Digital Land Mobile Radio Communications, Venice, 30 June–3 July 1987* pp. 355–9
- [6.17] Uddenfeldt, J. and Persson B., 1987 A Narrowband TDMA System for a New Generation Cellular Radio *37 IEEE Vehicular Technology Conference, Tampa, Florida, 1–3 June 1987* pp. 286–92
- [6.18] Stjernvall, J., Hedberg, B. and Ekemark S., 1987 Radio Test Performance of a Narrowband TDMA System *37 IEEE Vehicular Technology Conference, Tampa, Florida, 1–3 June 1987* pp. 293–9
- [6.19] Balston, D. M., 1989 Pan-European Cellular Radio: or 1991 and All That *Electron. Communi. Eng. J.* January/February 1989 pp. 7–13
- [6.20] Ericsson Radio Systems AB, Stockholm, Sweden, 1988 *RF-Technology System Concept for Digital Cellular* EIA Technical Subcommittee, TR 45. 3, Digital Cellular Standards, 11–13 May 1988, Washington DC
- [6.21] Lev, V., 1988 *Motorola's View on the Future of Cellular Radio in North America* EIA Technical Subcommittee, TR 45. 3, Digital Cellular Standards, 11–13 May 1988, Washington DC
- [6.22] Tarallo, J. A. and Zysman, G. I., 1987 A Digital Narrow-Band Cellular System *37 IEEE Vehicular Technology Conference, Tampa, Florida, 1–3 June 1987* pp. 279–80
- [6.23] Tarallo, J. A. and Zysman, G. I., 1988 Modulation Techniques for Digital Cellular Systems *38 IEEE Vehicular Technology Conference, Philadelphia, Pennsylvania, 15–17rd June 1988* pp. 245–8
- [6.24] AT&T Bell Laboratories, 1988 *Digital Cellular Network Architecture, Standards and RF Technologies* EIA Technical Subcommittee, TR 45. 3, Digital Cellular Standards, 11–13 May 1988, Washington DC
- [6.25] NEC Corporation, Japan, 1988 *Digital Cellular System* EIA Technical Subcommittee, TR 45. 3, Digital Cellular Standards, 11–13 May 1988, Washington DC

- [6.26] Akaiwa, Y. and Nagata, Y., 1987 Highly Efficient Digital Mobile Communications with a Linear Modulation Method *IEEE J. Sel. Areas Commun.* **SAC-5** (5) June pp. 890-5
- [6.27] Akaiwa, Y. and Nagata, Y., 1987 A Linear Modulation Scheme for a Spectrum Efficient Digital Mobile Telephone System *Proc. International Conference on Digital Land Mobile Radio Communications, Venice, 30 June-3 July 1987* pp. 218-26
- [6.28] Ono, S., Kondoh, N. and Shimazaki, Y., 1989 Digital Cellular System with Linear Modulation 39 *IEEE Vehicular Technology Conference, San Francisco, California 1-3 May 1989* pp. 44-9

# 7

## **Methods of Obtaining a Value for the Protection Ratio**

### **7.1 INTRODUCTION**

Cellular land mobile radio systems are interference limited and the protection ratio plays a particularly important role in assessing their spectral efficiency. This is self evident from the results obtained earlier, which established that the spectral efficiency is inversely proportional to, at least, the square root of the protection ratio. Despite the importance of the protection ratio, there is still a dearth of published information of a practical character on actual protection ratios measured under realistic conditions. Moreover, the methods by which some protection ratio figures are obtained are not very convincing. It is necessary, therefore, to agree upon a standard systematic method by which the protection ratio can be evaluated. Such a standard method should account for all propagation effects on the radio signal. Any technique which is believed to enhance the performance of a particular system could also be included.

This chapter addresses the definition and mathematical interpretation of the protection ratio. Before discussing the various methods by which the protection ratio may be evaluated, the advantages and disadvantages of each method are presented. The chapter concludes with some suggestions and recommendations for the evaluation of the protection ratio within cellular systems.

### **7.2 DEFINITION AND MATHEMATICAL REPRESENTATION OF THE PROTECTION RATIO**

The World Administrative Radio Conference held in Geneva in 1979, defined the protection ratio as: *the minimum value of the wanted-to-*

unwanted signal ratio, usually expressed in decibels, at the receiver input determined under specified conditions such that a specified quality is achieved at the receiver output [7.1]. This value may have different values according to the type of modulation system used and the quality of service required. The above definition of protection ratio appears to be a comprehensive one. However, in cellular systems, it is necessary to have a standard set of conditions under which the protection ratio is assessed as well as a standard voice quality. Furthermore, to ensure that consistent values of protection ratios are obtained, the method of assessment itself needs to be standardized. Various methods to evaluate the protection ratio are discussed in section 7.3.

To represent the protection ratio mathematically, it is important to realize that co-channel interference in cellular systems is actually the

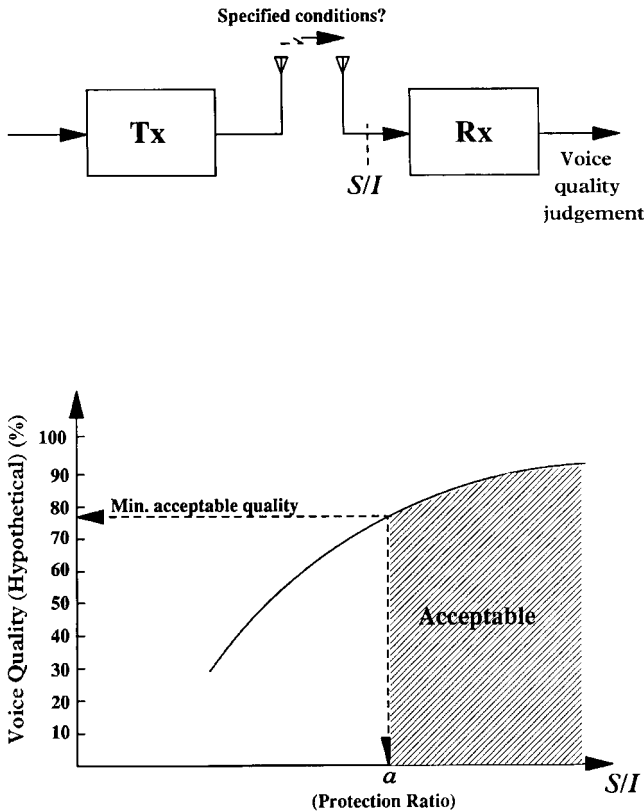

Figure 7.1 Graphical Representation of Protection Ratio

limiting factor to their performance/efficiency, not the total noise in the system. This is because the unwanted interfering signal power at the receiver input is much higher than the total noise power in the system and hence the latter can be ignored. Mathematically:

$$\text{protection ratio, } a = \min \left\{ \frac{S}{(I + N_s)} \right\} \quad (7.1)$$

for a specified signal quality

$$\therefore \text{protection ratio, } a \approx \min \left\{ \frac{S}{I} \right\} \quad (7.2)$$

for a specified signal quality and  $I \gg N_s$

where  $\min\{\}$  indicates the minimum value and  $S$ ,  $I$  and  $N_s$  have their usual meanings.

The protection ratio is represented graphically in Figure 7.1, where the 'specified' minimum acceptable voice signal quality is judged using an appropriate criterion. Note that  $S/I$  is measured at the input of the receiver and the quality is judged at its output.

## 7.3 METHODS OF EVALUATION

There are a number of conceivable methods by which the protection ratio may be evaluated. Such methods range from the possibility of mathematical derivation to subjective assessments. Field measurements are also possible. These methods are briefly presented and the advantages and disadvantages of each method are discussed.

### 7.3.1 Mathematical Derivation

To derive a value for the protection ratio mathematically, a relationship between the the signal to interference ratio ( $S/I$ ) at the receiver input, the receiver transfer function and the quality of the signal at the receiver output, needs to be established. The propagation effects on the wanted and interfering signals can be mathematically introduced using the fading and shadowing model discussed in section 3.6.8. The protection ratio is then the minimum  $S/I$  at the receiver input which gives rise to a given acceptable quality at the receiver output.

One major drawback of this method is the difficulty to realize and describe voice quality mathematically. One solution is to use the

signal to noise ratio at the receiver output as a measure of voice quality for analogue systems and the BER as a measure of quality for digital systems. However, it is still difficult to establish that a given S/N or BER can give rise to a certain acceptable voice quality. Furthermore, any technique which can improve the signal quality needs to be realized mathematically, which can also be very difficult. In all, this methodology can prove very tedious with a doubtful outcome for the protection ratio values.

### 7.3.2 Objective Measurements

Rather than trying to derive a value for the protection ratio mathematically, it is easier to perform some measurements in order to evaluate it. Following the above definition, an objective value for the protection ratio can be measured at the input of the receiver, depending on a pre-defined signal parameter at the receiver output which reflects the signal quality. For analogue modulation systems, the signal SINAD (signal+noise+distortion to noise+distortion) at the receiver output is usually taken as a 'figure of merit' which describes the signal quality. Figure 7.2 shows a possible test set up for objective protection ratio measurements. In the test, the desired signal is replaced by a mod-

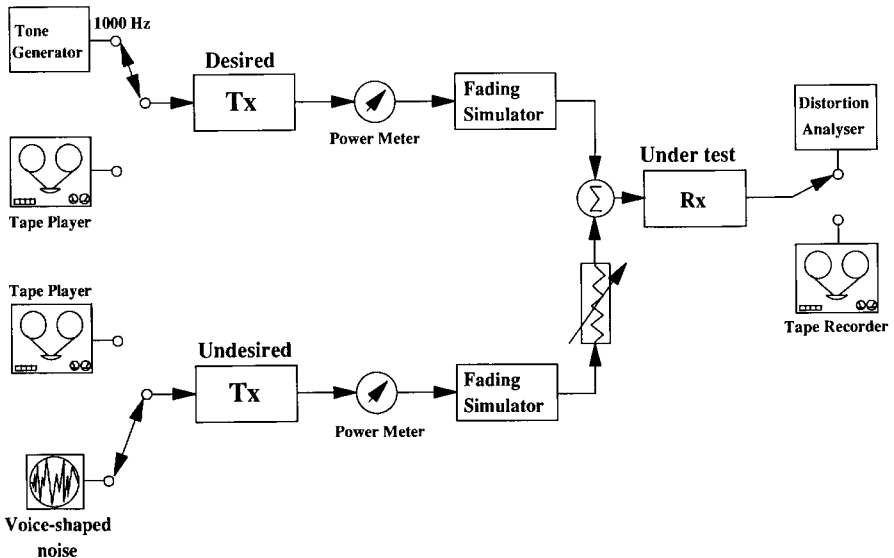

Figure 7.2 Possible Test Set-up for Objective/Subjective Protection Ratio Measurements



ulating tone, usually at 1000 Hz, and the interfering signal is either a voice shaped noise or a speech recording played back. The propagation effects on both the desired and interfering signals can be introduced using two independent fading simulators. By varying the signal to interference power ratio, a drop in the SINAD value of the desired signal, usually from 18 to 12 dB, is set as an indication of the modulation system performance under co-channel interference. Hence, the objective value for the protection ratio is the minimum signal to interference power ratio which causes a drop in the desired signal SINAD value from 18 to 12 dB.

Objective co-channel protection ratio measurements have been performed for 12.5 kHz PM, 12.5 kHz AM, 25 kHz PM, 25 kHz ACPM (amplitude companded PM), 5 kHz SSB and 5 kHz ACSB (amplitude companded SSB) [7.2, 7.3], and for 5 kHz ACSB [7.4]. A table summarizing objectively measured values of protection ratio for 25 kHz FM, NBFM and 5 kHz ACSB carried out by the NTIA (National Telecommunication and Information Agency, USA) is also given in [7.4].

Objective measurements of the protection ratio are relatively simple to carry out and can give an indication of the expected performance of a modulation system in a specified environment. Nevertheless, they have several disadvantages as follows:

- (a) They are specifically suitable for analogue modulation systems. A suitable objective protection ratio measurement for digital modulation systems would be to use the BER as a figure of merit which reflects the signal quality. In this case, the protection ratio is the minimum signal to interference ratio at the receiver input which gives rise to a specified BER of the desired signal at the receiver output, such that signal quality is acceptable.
- (b) Techniques which improve signal quality can be included in the tests. However, since the desired voice signal is replaced by only a modulating tone, propagation conditions such as frequency-selective fading will not have the same effect. Hence, the value of the objectively measured protection ratio does not represent the real situation. Also, the subjective improvement of companding, for example, and its ability to mitigate the effect of interference is nullified by the use of single tone modulation.
- (c) Large uncertainties in the SINAD reading can result due to fading [7.4], which can make the use of fading simulators impractical. It follows that propagation effects on the signals have to be excluded in this case, giving rise to non-realistic values for the protection ratio.

(d) Inconsistent protection ratio values have been obtained by different workers even though the same objective measurements were used. For example, the protection ratio for 5 kHz ACSB using the SINAD method was found to range between 8 dB (NTIA), 11 dB [7.4] and 24 dB [7.3]. The objectively measured protection ratio value for 25 kHz FM also varied – from 5 dB (NTIA) to 7.5 dB [7.3], which is far removed from the generally accepted value of 18 dB obtained through long experience and supported by subjective assessments.

(e) One should also question whether or not the SINAD, or a drop in the SINAD from 18 to 12 dB, does (or can) actually reflect voice signal quality.

The above reasons make the validity and effectiveness of such objective measurements questionable. Moreover, since the desired and interfering signals are subjective in nature, the ultimate test must be a subjective one.

### 7.3.3 Subjective Tests

In cellular systems, the protection ratio as a measure of voice signal quality implies a fidelity measure which is certainly a matter for subjective assessment. This involves human judgement of system performance. Such a judgement may be based on the quality, intelligibility, speaker recognizability or general acceptability of the received signal under realistic conditions.

In general, a subjective test employs voice modulated signals as desired and interfering signals and the received signal quality is judged by a group of listeners as to whether it is acceptable or not (according to a given scale). Figure 7.2 also shows possible test set-up for subjective protection ratio measurement. In the test, the desired transmitter is modulated with the output of a tape recorder playing back a recorded list of phrases acting as the desired signal. The interfering transmitter is modulated with the output of another recorder playing back continuous speech and acting as the interfering signal. As in the objective measurements, propagation effects can be introduced by the use of fading simulators. The desired signal to interfering signal power ratio is then varied, usually in 5 dB steps, and recordings of the received signal are made at each step. A panel of listeners, trained and/or otherwise, is then asked to assess the recorded speech, with reference to the CCIR five point scale (see Table 7.1). Instructions are given to the listeners so that fair judgement

**Table 7.1** CCIR Five-point Scale for the Subjective Tests (Mean Opinion Score)

Rating	Quality	Listening Effort
5	Excellent	Complete Relaxation Possible, No Effort Required
4	Good	Attention Necessary, No Appreciable Effort Required
3	Fair	Moderate Effort Required
2	Poor	Considerable Effort Required
1	Bad	No Meaning Understood With Any Feasible Effort

is ensured. The listeners are also unaware of the settings or type of equipment under test. The signal to interference ratio is plotted against the mean opinion score (MOS). Hence, the protection ratio is the minimum signal to interference ratio which gives rise to the specified signal quality.

Subjective co-channel protection ratio tests have been performed for 5 kHz ACSB and 25 kHz FM [7.4, 7.5] and typical results are shown in Figure 7.3. Subjective tests for PM, AM and SSB analogue modulation systems have been performed [7.2, 7.3] with a slight difference in the method – the listeners were asked to set the interfering signal level at the maximum tolerable level.

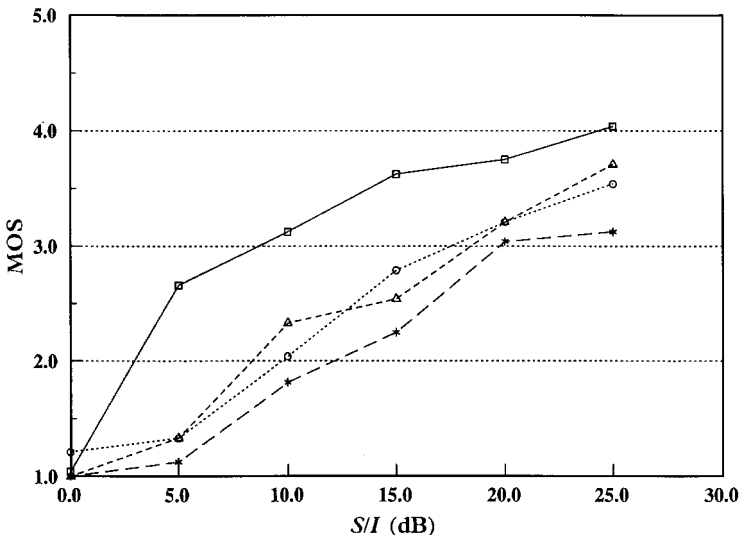

**Figure 7.3** MOS Versus  $S/I$ , Subjective Assessment. □, 25 kHz FM, No Fading; △, 5 kHz ACSB, No Fading; ○, 25 kHz FM, Rayleigh Fading; \*, 5 kHz ACSB, Rayleigh Fading

Subjective protection ratio measurements are very time consuming and expensive to conduct. Otherwise, they have numerous advantages which make them superior to any of the other methods described above. Some of the advantages of subjective tests are as follows:

- (a) They are equally suitable for use in both analogue and digital modulation systems. This is particularly important in aiming for a standard method for protection ratio evaluation, rather than having to design a different 'tailor-made' method for different systems.
- (b) The protection ratio obtained by subjective methods are based on human perception which sums up system performance and includes all subsystems which are thought to improve signal quality and hence spectral efficiency. Moreover, users' opinions will judge the end product of the cellular system, and the users' satisfaction is, after all, what the system was built for in the first place.
- (c) Techniques which are thought to improve signal quality can be included in the subjective tests. The impact of employing such techniques on the signal quality will manifest itself in terms of some improvement in the value of the protection ratio. For example, the effect of various techniques on the signal quality such as signal diversity reception, companding, automatic frequency control (AFC), automatic gain control (AGC), equalization and coding for digital systems, etc., can all be tested in terms of the protection ratio.
- (d) The protection ratio evaluated using subjective tests will inherently account for the noise in the system as well as the interference, and in this case Equation (7.1) applies. For digital systems, quantization noise will be inherently included along with system noise and interference.

Subjective tests are thus very effective and superior to objective measurements. One shortcoming is, however, that subjective tests as described above are performed under simulated laboratory conditions. A still better method to evaluate the protection ratio subjectively is the use of field measurements.

#### **7.3.4 Field Trials**

The protection ratio can be subjectively assessed in the real mobile radio environment instead of trying to simulate the propagation effects on the signal. This method accounts for the practical propaga-

tion effects on both the desired and interfering signal. In fact, subjective tests using field trials are similar to the subjective tests described above but with the difference that it is performed in the real mobile radio environment. This method entails using a transmitter site modulated with the output of a tape recorder playing back a recorded list of phrases acting as the desired signal. A second transmitter site is modulated with the output of another tape recorder playing back continuous speech and acting as the interfering signal. The desired and interfering transmitters are separated by a distance such that the signals received from the two transmitters are uncorrelated. The receiver is mounted on a vehicle which is driven around a typical test loop. The desired to interfering signal power ratio is then varied, say in 5 dB steps, and recordings of the received signal are made at each step. The recorded speech is then assessed by a panel of listeners according to the CCIR five point scale in exactly the same fashion as in the subjective tests described before. Hence, the signal to interference ratio is plotted against the MOS and, for a specified signal quality, the protection ratio is deduced.

Subjective co-channel protection ratio assessment using field trials have been performed for 12.5 and 25 kHz FM, 12.5 kHz AM and 5 kHz SSB [7.6]. This study included extensive field trials in urban, suburban and rural areas. Field trials have also been carried out to compare the performance of 5 kHz SSB with that of 25 kHz FM [7.7].

A subjective assessment of the protection ratio using field trials is undoubtedly the most effective method, since the system is evaluated in the very environment of operation. However, this method can prove time consuming and expensive to carry out, but it remains an option for established systems.

## **7.4 COMPARISON OF EVALUATION METHODS AND RECOMMENDATIONS**

As described above, there are several methods by which the protection ratio may be evaluated. Attempts to derive a value for the protection ratio mathematically can prove very tedious and with doubtful results. The mathematical method may be used for data communication over mobile radio systems, but is not usable for voice communication. Objective measurements are relatively simple to carry out but have certain disadvantages. In particular, the use of the SINAD ratio as an objective signal quality measure is rather vulnerable. Objective tests which reflect the voice quality are

intensively sought, but are difficult to establish with generality. The most promising and effective method is the subjective test, since voice signals are themselves subjective in nature. Field trials to assess the protection ratio subjectively are the ultimate method because they are performed in the real mobile radio environment where all propagation effects are naturally included in the tests.

Subjective tests and field trials have been performed for various systems, however, the methods employed have the following two main disadvantages:

- (a) They use only one interferer. This is not the case in a cellular system where six active interferers are possible.
- (b) Despite the fact that some of the reported measurements are highly elaborate, there is a common trend in all the works – a value for the protection ratio of the various systems under test is not given. This is mainly because a ‘specified signal quality’ is not agreed upon. For example, the signal quality is specified in [7.8] by: *The level at which 75% of the users state that the voice quality is either good or excellent in 90% of the service area.* In [7.9] the signal quality is specified by: *The minimum ratio of wanted to unwanted signal level for satisfactory reception and* in [7.3] the signal quality is set by: *The signal level ratio needed not to impair speech quality.* It is obvious that some of the terms used to specify signal quality are rather loose, hence the difficulty in producing consistent values for the protection ratio.

#### **7.4.1 Recommendations and Suggestions for the Subjective Assessment of the Protection Ratio**

- (a) Six co-channel interferers should be used in the subjective tests. Figure 7.4 shows a suggested laboratory test set-up, where all the fading simulators and played-back interfering speech messages operate independently. The voice quality is assessed and the protection ratio is deduced in the same way as before. In field trials, six transmitter sites should be employed to act as the interfering transmitters, as is the case in a practical fully developed cellular system.
- (b) It is crucial to agree upon and carefully specify the adequate signal quality in order to deduce consistent values for the protection ratio. The best approach is to use the CCIR five point scale and then to specify which level represents the required signal quality. If toll quality is the target, for example, it should be possible to specify a

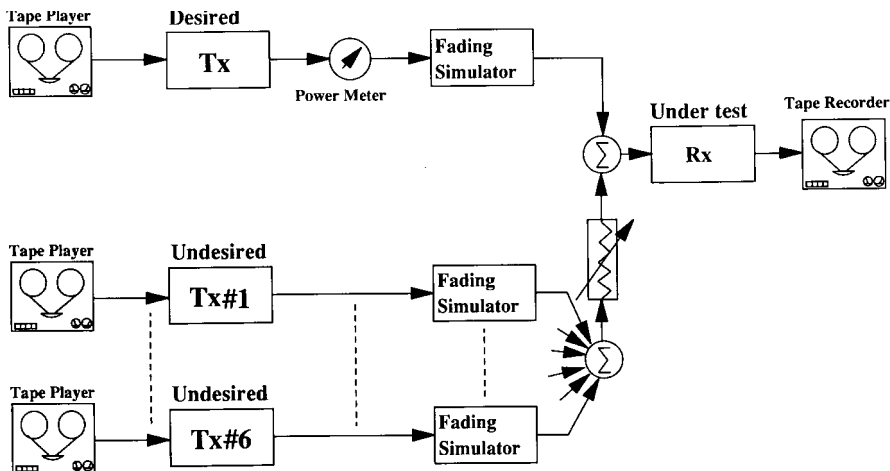

**Figure 7.4** Suggested Test Configuration for Subjective Protection Ratio Measurements

point on the CCIR five-point scale which corresponds to the required quality. This does not necessarily need to coincide with one of the five points and may lie somewhere between two points (for instance, half way between good and fair).

(c) In order to ensure fair and consistent values for the protection ratio, it is important to standardize a subjective test method by which the protection ratio is assessed. This includes standard test set-ups, test conditions, number of interferers, signal quality, desired and interfering speech, qualifications of the panel of assessing listeners, instructions to the panel of listeners, tape recorders, etc. Standardization should be carried out by independent consultative committees such as the CCIR and the CCITT. Such standards have then to be enforced by regulatory authorities, such as the Radio Regulatory Division (RRD) in the Department of Trade and Industry (DTI) in the UK and the Federal Communications Commission (FCC) in the USA.

(d) One step beyond standardization is to set a mandatory requirement for companies competing in the market to submit their systems (transmitters and receivers, etc.) to an independent appointed body for the protection ratio to be assessed and hence for the spectral efficiency of the systems to be evaluated. In our opinion this is necessary for the establishment of fair competition and would also ensure that cellular systems which can provide both signal quality and spectral efficiency are employed.

(e) Finally, subjective test methods can be used to make an effective compromise between signal quality and spectral efficiency. To give an example, coding in digital systems can improve signal quality and guard against interference; however, it also entails a sacrifice in bandwidth. The problem then is how to use minimum coding in order to achieve the required signal quality with minimum waste in terms of bandwidth. This can be optimized by using different amounts/types of coding and assessing the protection ratio each time. Using the modulation efficiency formula, the spectral efficiency can then be evaluated for each amount/type of coding using the protection ratio and the corresponding channel spacing. Hence, the optimum amount/type of coding is that which gives rise to the maximum spectral efficiency. The same method can be applied to modulation systems which trade bandwidth for improved signal quality such as in FM systems and systems which employ spread spectrum techniques.

## REFERENCES

- [7.1] CCIR, 1986 *Report 358-5, XVI Plenary Assembly, Dubrovnik* Vol. VIII-1, International Telecommunication Union pp. 3-13
- [7.2] Hansen, F., 1981 *Modulation Techniques for Land Mobile Radio: Part 1 Telecomm. J.* **48** (VIII) pp. 472-7
- [7.3] Hansen, F., 1981 *Modulation Techniques for Land Mobile Radio: Part 2 Telecomm. J.* **48**, (IX) pp. 530-7
- [7.4] Home Office Directorate of Radio Technology, 1986 *Co-channel Measurements for Amplitude Companded SSB Voice Communications* Home Office, Department of Trade and Industry, Radio Communication Division, UK
- [7.5] Bateman, A., *et al.*, 1987 *Co-channel Measurements for Amplitude Companded SSB Voice Communications 37<sup>th</sup> IEEE Vehicular Technology Conference, Tampa, Florida, 1-3 June 1987* pp. 505-11
- [7.6] Home Office Directorate of Radio Technology, 1982 *Report on Comparative Tests of Modulation Methods for Private Mobile Radio* Home Office, Radio Regulatory Department, UK
- [7.7] Garner, P. J., 1980 *Co-channel and Quasi-synchronous Characteristics of SSB Relative to FM Mobile Radio Communication Systems IEE Conf. Proc. Communication Equipment and Systems* **184** pp. 174-7
- [7.8] MacDonald, V. H., 1979 *Advanced Mobile Phone Services: The cellular Concept Bell Syst. Tech. J.*, **58**, (1) January pp. 15-41
- [7.9] French, R. C., 1979 *The Effect of Fading and Shadowing on Channel Re-use in Mobile Radio IEEE Trans. Veh. Technol.* **VT-28** (3) August pp. 171-81



# 8

## **Concluding Remarks**

The research presented in this book covers global approaches to the definition and evaluation of spectral efficiency which accounts for all pertinent system parameters in a cellular mobile radio system, and the ease of practical applicability to all existing and proposed, analogue and digital, cellular systems. Hence, such systems can be set in a ranked order of spectral efficiency.

It has been shown that the best measures of spectral efficiency for cellular land mobile radio systems using voice transmission are:

- Channels/MHz/km<sup>2</sup>
- Erlangs/MHz/km<sup>2</sup>
- Users/MHz/km<sup>2</sup>.

The above measures account for the spatial re-use of frequency, characteristic to cellular systems, as well as channel spacing. They also account for the quality of service offered by different systems in terms of both the voice quality and the grade of service. For data based cellular services such as telex and facsimile, the spectral efficiency measure in terms of kbps/MHz/km<sup>2</sup> is useful. In this case, the quality is defined in terms of the BER under specified signal conditions. This book primarily deals with voice transmission, analogue and digital, for two reasons. Firstly, speech is, and will always be, the principal medium of telecommunication. Secondly, it has been demonstrated that comparisons of the spectral efficiency of data services (with the exception of the digitized voice) are trivially obtained using objective methods.

In order to evaluate the spectral efficiency of various cellular systems, the above spectral efficiency measures were mathematically

interpreted. In doing that, the method distinguished between the spectral efficiency of the modulation technique and the efficiency of multiple access technique of a cellular system. For the sake of convenience and flexibility, the two types of spectral efficiency were dealt with separately.

The modulation efficiency  $\eta_M$  expressed in Channels/MHz/km<sup>2</sup> was shown to be inversely proportional to the channel spacing  $B_c$ , the cell area  $A$  and the number of cells per cluster  $N_c$ . Also,  $\eta_M$  was shown to be independent of the total bandwidth  $B_t$  allocated to the system, excluding multiple access efficiency considerations.

The number of cells per cluster  $N_c$  was shown to be an important parameter which depends on the cell shape as well as the model used to calculate the co-channel interference in the system. For its various advantages, hexagonal geometry was adopted and hexagonal cell shapes were assumed. Hence,  $N_c$  was given in terms of the co-channel re-use ratio  $D/R$ . The co-channel re-use ratio was in turn related to the co-channel protection ratio which reflects the signal quality of a modulation technique within a cellular system.

To establish a mathematical relationship between the protection ratio and the co-channel re-use ratio, it was necessary to model the cellular land mobile radio system so as to account for propagation effects on the radio signal. It was also necessary to model the relative geographical locations of the transmitters and receivers in the system to be able to predict all the significant co-channel interference on the desired signal. The adjacent channel interference was ignored.

Two main categories of co-channel interference models were compared. The first category was a geographical one, in which the models were constructed considering the relative geographical locations of the transmitters and receivers. Considering different possible numbers of interferers in the cellular system, three geographical models were compared: a one-interferer model, a six-interferer model and a model of many tiers of interferers. The second category is a statistically based group of models, in which propagation effects, mainly fading and shadowing, were included in a statistical fashion. Three statistical models were compared: a fading only model, a shadowing only model and a fading and shadowing model. Given a value for the protection ratio, the co-channel interference models were used to derive the number of cells per cluster  $N_c$ .

In comparing the six models, the geographical model with six interferers was shown to have many advantages. These include resemblance to real situations, ease of application in practice and that a subjectively assessed protection ratio can be used. A mathema-

tical justification for the geographical model with six interferers was also presented using analytical results for propagation over a 'plane earth'.

Using the six-interferer geographical model, the modulation efficiency  $\eta_M$  was presented as a function of four system parameters: the channel spacing  $B_c$ , protection ratio  $a$ , propagation constant  $\alpha$  and the cell area  $A$ . The channel spacing and the protection ratio are directly related to the modulation technique, and since the protection ratio reflects the voice signal quality, it needs to be subjectively assessed under realistic conditions. The propagation constant  $\alpha$  is dependent on the nature of the terrain and the urbanization degree and usually has a value between three and four which can be obtained by means of field measurements.

The spectral efficiency of a modulation technique is inversely proportional to the cell area. Hence, the spectral efficiency can be maximized by minimizing the cell area. Theoretically, cellular systems can continue to grow indefinitely through the process of cell splitting. However, there are several dominant factors which limit the minimum cell area that can be achieved in practice. For smaller cells the hand-off rate becomes unacceptably high, it becomes more difficult to page and locate mobiles and more control channels become necessary which will reduce the spectral efficiency. Also, co-channel interference becomes more difficult to manage for smaller cells. Furthermore, environmental, legal and zoning restrictions as well as site availability problems become more difficult as cells become smaller. Considering the above restricting factors, a cell radius as small as 1 km appeared to be practical and was used in the spectral efficiency comparison of various cellular systems.

Digital systems are becoming increasingly popular to the extent that Europe, North America and Japan are well advanced in their implementations of digital cellular systems. Advantages of digital cellular systems include compatibility with ISDN which can support data as well as voice transmission, security through encryption can be easily implemented and they can incorporate enhanced capabilities by allowing the integration of components with VLSI which can result in smaller and cheaper equipment. For the above reasons it is necessary to consider the evaluation of the spectral efficiency of digital modulation techniques.

The spectral efficiency evaluation method can be easily applied to digital modulation, mainly because the co-channel interference models are independent of the modulation technique employed. Channel spacing in digital systems is usually defined in terms of

kbps and it is necessary to evaluate that in kHz. Also, it is possible to assess the protection ratio objectively using the BER as a measure of quality.

Two approaches to evaluate the channel spacing and the protection ratio were presented. The first method was to combine the voice coder bit rate in kbps and the speed of the digital modulation to obtain an equivalent channel spacing in kHz. In this method the protection ratio needed to be subjectively assessed. In the second method, the channel spacing was evaluated in the same way, however, the objective protection ratio was derived based on the BER and  $E_b/N_0$ . A 16 kbps voice coding and a random BER of less than 1 in 100 for adequate voice quality are assumed. Comparing the two methods, it was concluded that the objective approach is useful for the general comparison of voice coders combined with digital modulation and in the absence of subjective protection ratio values. Nevertheless, the subjective approach to evaluating the protection ratio for cellular systems was thought to be superior.

A study of voice coders was necessary and showed that efficient use of digital modulation for cellular systems will depend a great deal upon the choice of a voice coder. Because of the synthetic quality they offer, vocoders are not adequate for cellular systems despite their efficient use of spectrum. On the other hand, wave coders with bit rates above 32 kbps entail a big sacrifice in terms of bandwidth and hence their use with cellular systems is prohibitive. Hybrid voice coders can achieve a good quality with bit rates between 7.2 and 16 kbps and are thus considered suitable for cellular systems. The spectral efficiency of digital cellular systems is expected to increase with the use of more efficient voice coders which may become available in the near future.

The terms modulation and multiple access are used to define two entirely different matters and hence the efficiency they contribute is separable. A method was devised in order to compare and evaluate the spectral efficiency of different multiple access techniques, such as FDMA, TDMA and CDMA.

In theory, all multiple access techniques have a potential 100% relative spectral efficiency provided that the channels are orthogonal. Furthermore, it has been shown that even if the transmission system meets Shannon's capacity law, orthogonal multiple access techniques are superior in their spectral efficiency to non-orthogonal techniques. That is to say, FDMA and synchronous TDMA are superior in their spectral efficiency to asynchronous TDMA and CDMA. It was also concluded that loss in orthogonality causes considerable loss in capa-

city. Some theoretical studies have shown that if the multiple access interference could be modelled as AWGN, the relative efficiency of asynchronous multiple access, in general, was in the vicinity of 70% of synchronous techniques.

To derive the efficiency of multiple access techniques, it was necessary to consider their performance in practice. A multiple access efficiency factor was defined and mathematically interpreted for various multiple access techniques. A set of equations were established and the multiple access efficiency factor was evaluated for FDMA, TDMA and CDMA techniques. Using some available data from practical systems, it was shown that analogue FDMA has a multiple access efficiency factor of around 95%, while for digital FDMA it is about 85%. For TDMA techniques, the value was in the vicinity of 67%. Data for a pure CDMA cellular system are unavailable at the time of writing, however, a value around 65% is expected.

Although the above efficiency figures clearly show that FDMA techniques offer superior spectral efficiency to TDMA, the latter was chosen for the Pan-European cellular system for reasons of compatibility with digital systems. In our opinion this is unjustified since digital FDMA techniques can be used instead which offer better efficiency than TDMA. The Japanese cellular system will employ a hybrid NB-TDMA/FDMA while the North American proposals include all the three options (i.e. digital FDMA, NB-TDMA and a hybrid).

The overall spectral efficiency of a cellular system was found by combining the spectral efficiency of the modulation technique and the multiple access efficiency factor. Some remarks of how the method is applied to various systems were made. The results were then used to predict the effect of bandwidth expansion, characteristic to some systems, on the spectral efficiency. It has been shown that, within a cellular system, expanding the channel spacing using spread spectrum techniques is not feasible for  $\alpha > 2$  and that expanding the channel spacing using WBFM is not spectrally feasible for  $\alpha > 3$ .

The spectral efficiency of various analogue modulation techniques was evaluated using subjective protection ratio values. It has been shown that SSB offers the highest spectral efficiency in terms of Channels/MHz/km<sup>2</sup> with a value about 3.8 times the efficiency of a conventional 25 kHz FM technique. It has also been shown that 12.5 kHz FM is more efficient than 25 or 30 kHz FM, confirming that expanding the bandwidth using WBFM is not spectrally feasible. AM techniques were shown to be the least efficient.

A representative set of digital modulation techniques was compared in terms of their spectral efficiency using objective values for

the protection ratio, since there is a scarcity of subjectively measured protection ratios. Amongst the digital systems evaluated, QAM was shown to be the most efficient AM digital technique, MSK the most efficient FM technique, QPSK the most efficient PM technique and 4-APK the most efficient AM/PM hybrid scheme. 4-APK, (QPSK and QAM) can offer 7.64 Channels/MHz/km<sup>2</sup> which is about 3.8 times the spectral efficiency of a conventional 25 kHz FM analogue system.

An alternative spectral efficiency measure in terms of Erlangs/MHz/km<sup>2</sup> was interpreted mathematically. Using a blocking system traffic model, the spectral efficiency can be evaluated in Erlangs/MHz/km<sup>2</sup>, given the grade of service and the average traffic per user.

A representative set of first- and second generation cellular systems was evaluated in terms of spectral efficiency for  $\alpha = 3, 3.5$  and 4. Assuming a cell radius of 1 km and that all values of  $N_c$  are possible,  $\eta_T, \eta_C, \eta_R, \eta_E$  and  $\eta_U$  were evaluated for each cellular system. Grades of service of 2% and 5% and a traffic intensity of 0.05 Erlangs/User were used. All cellular systems were assumed to be working in a 10 MHz band.

Results for the first-generation analogue cellular systems have shown that various FM/FDMA cellular systems have more or less the same spectral efficiency, with 12.5 FM systems offering a slight advantage. An ACSSB/FDMA system could offer up to four times the spectral efficiency of a conventional FM/FDMA system. ACSSB/FDMA systems could accommodate up to 155 Users/MHz/km<sup>2</sup> compared with only 36 Users/MHz/km<sup>2</sup> offered by FM cellular systems.

In contrast to FM/FDMA cellular systems, which are mature and well established, digital cellular systems have had less experience within a cellular mobile radio environment. Moreover, subjectively measured protection ratios for digital cellular systems are generally unavailable; hence it was necessary to use objective values for the assessments.

The cellular system which was finally chosen for Europe is GMSK/NB-TDMA based digital system. It can accommodate up to 59 Users/MHz/km<sup>2</sup> – a value which is expected to double when lower bit rate toll-quality voice coders become available. In our opinion this is not the most spectrally efficient solution compared with other proposals for Europe. A 16 kbps voice coder with GMSK appears to be a good option, but the channel spacing used is too extravagant.

The most promising proposals for North America are based on QPSK/NB-TDMA and can accommodate up to 155 Users/MHz/km<sup>2</sup>. Japan is well advanced in its implementation of a  $\pi/4$  QPSK/NB-TDMA/FDMA cellular system, which can accommodate up to

125 Users/MHz/km<sup>2</sup>. This is also expected to increase with the use of more efficient voice coders.

In general, the results have shown that the move from the first-generation FM/FDMA cellular systems is spectrally feasible/justifiable. An ACSSB/FDMA cellular system can offer a spectral efficiency comparable to that of digital systems. However, because of the numerous advantages which digital systems offer, they seem to be an inevitable choice. In particular, advancement in voice coding techniques could provide voice coders with much lower bit rates which will lead to even more efficient digital cellular systems.

Cellular systems are interference limited and the protection ratio plays a crucial role in the assessment of spectral efficiency. Despite the importance of the protection ratio, there is little published information of a practical character on actual protection ratios measured under realistic conditions. For consistent spectral efficiency figures and fair comparisons, a standard systematic method by which the protection ratio can be evaluated needs to be agreed. Such a method should account for all propagation effects on the radio signal and include any technique believed to enhance the performance of any particular system. An attempt to outline such a method and recommendations and suggestions for future work were made.

A suitable definition and mathematical representation of the protection ratio were presented. Possible methods to evaluate the protection ratio include mathematical derivation, objective measurements, subjective tests and field trials. A mathematical derivation of the protection ratio can be tedious with doubtful results. Objective methods are relatively simple to carry out but the criterion used to reflect voice quality is difficult to establish with generality. Subjective methods are promising and effective, since voice signals are subjective in nature. Field trials to assess the protection ratio subjectively are considered to be the ultimate method since they are performed in the real mobile environment where propagation effects are naturally included. Subjective tests are, however, expensive and time consuming.

# 9

## ***Recommendations and Suggestions for Future Work***

More attention needs to be given to spread spectrum systems, in particular with regard to the efficiency of CDMA technique. Although it is believed that the criteria used in this report are suitable for the evaluation of proposed spread spectrum systems, a more detailed study might be needed. There is another factor which emerges in this respect, which relates to the shortage of material concerning practical CDMA/spread spectrum systems which can be used as a guide.

Coding in digital systems can improve signal quality and guard against interference, however, it also entails a sacrifice in bandwidth. The problem has always been how to use minimum coding in order to achieve the required signal quality with minimum waste in terms of bandwidth. Further work is necessary to optimize the use of spectrum using different amounts/types of coding and in each case assessing the protection ratio. Using the modulation efficiency formula, the spectral efficiency can then be evaluated for each amount/type of coding using the corresponding protection ratio and channel spacing. Hence, the optimum amount/type of coding is that which gives rise to the maximum spectral efficiency. The same method can be applied to modulation systems which trade bandwidth for improved signal quality such as spread spectrum techniques. Moreover, subjective methods can be used to test the effect of various techniques which are believed to enhance the spectral efficiency such as amplitude companding, AGC, AFC, APC, etc.

It would be interesting to establish a mathematical relation between the protection ratio and  $S/I$  for different modulation techniques. The main task is to find an objective criterion which can be used to reflect



voice quality. Such a relation is easier to generalize for digital systems using the BER as a signal quality measure.

Standardization of a subjective method to evaluate the protection ratio is necessary. Such a standard method could benefit from the spectral efficiency evaluation method presented and the various recommendations given at the end of Chapter 7.

A minimum cell radius of 1 km was assumed for several practical considerations. It would be interesting, however, to see if the cell area can be established as function of some system parameters related to the modulation technique used. This could give an indication to the minimum possible cell area for each modulation technique and hence its maximum spectral efficiency.

Further work is necessary to assess subjectively the protection ratios of various digital modulation techniques in order to evaluate their spectral efficiency.

More work is also needed to evaluate the spectral efficiency of data services within cellular systems. It is recommended that  $\text{kbps}/\text{MHz}/\text{km}^2$  is used as a spectral efficiency measure and a quality criterion in terms of the BER would be adequate.

Research at Bristol University, UK, carried out to find power efficient digital techniques for hand-portable cellular systems. It would be interesting to combine the results of this research with the findings in this book to arrive at a digital cellular system that is both spectrally and power efficient; this will be the subject of a future publication.

# Appendix A: An Alternative Co-channel Interference Model

In a fully equipped hexagon-shaped cellular system, there are always  $6m$  co-channel cells in the  $m$ th tier, regardless of the number of cells per cluster (see Figure 3.13). *At the mobile station:*

$$S \propto 1/R^\alpha. \quad (\text{A.1})$$

The total interference from all co-channel cells is given by:

$$I \propto [6/D^\alpha + 12/(2D)^\alpha + 18/(3D)^\alpha + 24/(4D)^\alpha + \dots] \quad (\text{A.2})$$

$$I \propto [6/D^\alpha + 6 \times 2 \times (2D)^\alpha + 6 \times 3 \times (3D)^\alpha + 6 \times 4 \times (4D)^\alpha + \dots]. \quad (\text{A.3})$$

Hence, the total interference from all co-channel cells, up to tier  $T$  is:

$$I \propto \sum_{m=1}^T \frac{6m}{(mD)^\alpha} \quad (\text{A.4})$$

$$\therefore \frac{S}{I} = \left(\frac{D}{R^\alpha}\right) \frac{1}{6 \sum_{m=1}^T \frac{1}{m^{\alpha-1}}}. \quad (\text{A.5})$$

Hence:

$$\frac{D}{R} = \left[6\left(\frac{S}{I}\right)\right]^{1/\alpha} \left(\sum_{m=1}^T \frac{1}{m^{\alpha-1}}\right)^{1/\alpha} \quad (\text{A.6})$$

and

$$N_c = \frac{1}{3} \left[6\left(\frac{S}{I}\right)\right]^{2/\alpha} \times \left(\sum_{m=1}^T \frac{1}{m^{\alpha-1}}\right)^{2/\alpha}. \quad (\text{A.7})$$

## ***Appendix B: Erlang B Table-Blocked Calls Cleared Model***

Table B.1 shows the amount of traffic (in Erlangs) carried by a given number of channels  $n$  for different blocking probability values.

**Table B.1** Erlang B Model—Blocked Calls Cleared

n	(Offered Load)													
	A in Erlangs													
	$P_B$ (Blocking Probability)													
	0.01%	0.02%	0.03%	0.05%	0.1%	0.2%	0.3%	0.4%	0.5%	0.6%	0.7%	0.8%	0.9%	
1	0.0001	0.0002	0.0003	0.0005	0.0010	0.0020	0.0030	0.0040	0.0050	0.0060	0.0070	0.0081	0.0091	
2	0.0142	0.0202	0.0248	0.0321	0.0458	0.0653	0.0806	0.0937	0.105	0.116	0.126	0.135	0.1443	
3	0.0868	0.110	0.127	0.152	0.194	0.249	0.289	0.321	0.349	0.374	0.397	0.418	0.4374	
4	0.235	0.282	0.315	0.362	0.439	0.535	0.602	0.656	0.701	0.741	0.777	0.810	0.8415	
5	0.452	0.527	0.577	0.649	0.762	0.900	0.994	1.07	1.13	1.19	1.24	1.28	1.326	
6	0.728	0.832	0.900	0.996	1.15	1.33	1.45	1.54	1.62	1.69	1.75	1.81	1.867	
7	1.05	1.19	1.27	1.39	1.58	1.80	1.95	2.06	2.16	2.24	2.31	2.38	2.448	
8	1.42	1.58	1.69	1.83	2.05	2.31	2.48	2.62	2.73	2.83	2.91	2.99	3.069	
9	1.83	2.01	2.13	2.30	2.56	2.85	3.05	3.21	3.33	3.44	3.54	3.63	3.7110	
10	2.26	2.47	2.61	2.80	3.09	3.43	3.65	3.82	3.96	4.08	4.19	4.29	4.3811	
11	2.72	2.96	3.12	3.33	3.65	4.02	4.27	4.45	4.61	4.74	4.86	4.97	5.07	
12	3.21	3.47	3.65	3.88	4.23	4.64	4.90	5.11	5.28	5.43	5.55	5.67	5.78	
13	3.71	4.01	4.19	4.45	4.83	5.27	5.56	5.78	5.96	6.12	6.26	6.39	6.50	
14	4.24	4.56	4.76	5.03	5.45	5.92	6.23	6.47	6.66	6.83	6.98	7.12	7.24	
15	4.78	5.12	5.34	5.63	6.08	6.58	6.91	7.17	7.38	7.56	7.71	7.86	7.99	
16	5.34	5.70	5.94	6.25	6.72	7.26	7.61	7.88	8.10	8.29	8.46	8.61	8.75	
17	5.91	6.30	6.55	6.88	7.38	7.95	8.32	8.60	8.83	9.03	9.21	9.37	9.52	
18	6.50	6.91	7.17	7.52	8.05	8.64	9.03	9.33	9.58	9.79	9.98	10.1	10.3	
19	7.09	7.53	7.80	8.17	8.72	9.35	9.76	10.1	10.3	10.6	10.7	10.9	11.1	
20	7.70	8.16	8.44	8.83	9.41	10.1	10.5	10.8	11.1	11.3	11.5	11.7	11.9	
21	8.32	8.79	9.10	9.50	10.1	10.8	11.2	11.6	11.9	12.1	12.3	12.5	12.7	
22	8.95	9.44	9.76	10.2	10.8	11.5	12.0	12.3	12.6	12.9	13.1	13.3	13.5	
23	9.58	10.1	10.4	10.9	11.5	12.3	12.7	13.1	13.4	13.7	13.9	14.1	14.3	
24	10.2	10.8	11.1	11.6	12.2	13.0	13.5	13.9	14.2	14.5	14.7	14.9	15.1	
25	10.9	11.4	11.8	12.3	13.0	13.8	14.3	14.7	15.0	15.3	15.5	15.7	15.9	
26	11.5	12.1	12.5	13.0	13.7	14.5	15.1	15.5	15.8	16.1	16.3	16.6	16.8	
27	12.2	12.8	13.2	13.7	14.4	15.3	15.8	16.3	16.6	16.9	17.2	17.4	17.6	
28	12.9	13.5	13.9	14.4	15.2	16.1	16.6	17.1	17.4	17.7	18.0	18.2	18.4	
29	13.6	14.2	14.6	15.1	15.9	16.8	17.4	17.9	18.2	18.5	18.8	19.1	19.3	
30	14.2	14.9	15.3	15.9	16.7	17.6	18.2	18.7	19.0	19.4	19.6	19.9	20.1	
31	14.9	15.6	16.0	16.6	17.4	18.4	19.0	19.5	19.9	20.2	20.5	20.7	21.0	
32	15.6	16.3	16.8	17.3	18.2	19.2	19.8	20.3	20.7	21.0	21.3	21.6	21.8	
33	16.3	17.0	17.5	18.1	19.0	20.0	20.6	21.1	21.5	21.9	22.2	22.4	22.7	
34	17.0	17.8	18.2	18.8	19.7	20.8	21.4	21.9	22.3	22.7	23.0	23.3	23.5	
35	17.8	18.5	19.0	19.6	20.5	21.6	22.2	22.7	23.2	23.5	23.8	24.1	24.4	
36	18.5	19.2	19.7	20.3	21.3	22.4	23.1	23.6	24.0	24.4	24.7	25.0	25.3	
37	19.2	20.0	20.5	21.1	22.1	23.2	23.9	24.4	24.8	25.2	25.6	25.9	26.1	
38	19.9	20.7	21.2	21.9	22.9	24.0	24.7	25.2	25.7	26.1	26.4	26.7	27.0	
39	20.6	21.5	22.0	22.6	23.7	24.8	25.5	26.1	26.5	26.9	27.3	27.6	27.9	
40	21.4	22.2	22.7	23.4	24.4	25.6	26.3	26.9	27.4	27.8	28.1	28.5	28.7	
41	22.1	23.0	23.5	24.2	25.2	26.4	27.2	27.8	28.2	28.6	29.0	29.3	29.6	
42	22.8	23.7	24.2	25.0	26.0	27.2	28.0	28.6	29.1	29.5	29.9	30.2	30.5	
43	23.6	24.5	25.0	25.7	26.8	28.1	28.8	29.4	29.9	30.4	30.7	31.1	31.4	
44	24.3	25.2	25.8	26.5	27.6	28.9	29.7	30.3	30.8	31.2	31.6	31.9	32.3	
45	25.1	26.0	26.6	27.3	28.4	29.7	30.5	31.1	31.7	32.1	32.5	32.8	33.1	
46	25.8	26.8	27.3	28.1	29.3	30.5	31.4	32.0	32.5	33.0	33.4	33.7	34.0	
47	26.6	27.5	28.1	28.9	30.1	31.4	32.2	32.9	33.4	33.8	34.2	34.6	34.9	
48	27.3	28.3	28.9	29.7	30.9	32.2	33.1	33.7	34.2	34.7	35.1	35.5	35.8	
49	28.1	29.1	29.7	30.5	31.7	33.0	33.9	34.6	35.1	35.6	36.0	36.4	36.7	
50	28.9	29.9	30.5	31.3	32.5	33.9	34.8	35.4	36.0	36.5	36.9	37.2	37.6	
N	0.01%	0.02%	0.03%	0.05%	0.1%	0.2%	0.3%	0.4%	0.5%	0.6%	0.7%	0.8%	0.9%	
	B													

**Table B.1** (Continued)

(Offered Load)		A in Erlangs												
n	$P_B$													
	1.0%	1.2%	1.5%	2%	3%	5%	7%	10%	15%	20%	30%	40%	50%	
1	0.0101	0.0121	0.0152	0.0204	0.0309	0.0526	0.753	0.111	0.176	0.250	0.429	0.667	1.00	
2	0.153	0.168	0.190	0.223	0.282	0.381	0.470	0.595	0.796	1.00	1.45	2.00	2.73	
3	0.455	0.489	0.535	0.602	0.715	0.899	1.06	1.27	1.60	1.93	2.63	3.48	4.59	
4	0.869	0.922	0.992	1.09	1.26	1.52	1.75	2.05	2.50	2.95	3.89	5.02	6.50	
5	1.36	1.43	1.52	1.66	1.88	2.22	2.50	2.88	3.45	4.01	5.19	6.60	8.44	
6	1.91	2.00	2.11	2.28	2.54	2.96	3.30	3.76	4.44	5.11	6.51	8.19	10.4	
7	2.50	2.60	2.74	2.94	3.25	3.74	4.14	4.67	5.46	6.23	7.86	9.80	12.4	
8	3.13	3.25	3.40	3.63	3.99	4.54	5.00	5.60	6.50	7.37	9.21	11.4	14.3	
9	3.78	3.92	4.09	4.34	4.75	5.37	5.88	6.55	7.55	8.52	10.6	13.0	16.3	
10	4.46	4.61	4.81	5.08	5.53	6.22	6.78	7.51	8.62	9.68	12.0	14.7	18.3	
11	5.16	5.32	5.54	5.84	6.33	7.08	7.69	8.49	9.69	10.9	13.3	16.3	20.3	
12	5.88	6.05	6.29	6.61	7.14	7.95	8.61	9.47	10.8	12.0	14.7	18.0	22.2	
13	6.61	6.80	7.05	7.40	7.97	8.83	9.54	10.5	11.9	13.2	16.1	19.6	24.2	
14	7.35	7.56	7.82	8.20	8.80	9.73	10.5	11.5	13.0	14.4	17.5	21.2	26.2	
15	8.11	8.33	8.61	9.01	9.65	10.6	11.4	12.5	14.1	15.6	18.9	22.9	28.2	
16	8.88	9.11	9.41	9.83	10.5	11.5	12.4	13.5	15.2	16.8	20.3	24.5	30.2	
17	9.65	9.89	10.2	10.7	11.4	12.5	13.4	14.5	16.3	18.0	21.7	26.2	32.2	
18	10.4	10.7	11.0	11.5	12.2	13.4	14.3	15.5	17.4	19.2	23.1	27.8	34.2	
19	11.2	11.5	11.8	12.3	13.1	14.3	15.3	16.6	18.5	20.4	24.5	29.5	36.2	
20	12.0	12.3	12.7	13.2	14.0	15.2	16.3	17.6	19.6	21.6	25.9	31.2	38.2	
21	12.8	13.1	13.5	14.0	14.9	16.2	17.3	18.7	20.8	22.8	27.3	32.8	40.2	
22	13.7	14.0	14.3	14.9	15.8	17.1	18.2	19.7	21.9	24.1	28.7	34.5	42.1	
23	14.5	14.8	15.2	15.8	16.7	18.1	19.2	20.7	23.0	25.3	30.1	36.1	44.1	
24	15.3	15.6	16.0	16.6	17.6	19.0	20.2	21.8	24.2	26.5	31.6	37.8	46.1	
25	16.1	16.5	16.9	17.5	18.5	20.0	21.2	22.8	25.3	27.7	33.0	39.4	48.1	
26	17.0	17.3	17.8	18.4	19.4	20.9	22.2	23.9	26.4	28.9	34.4	41.1	50.1	
27	17.8	18.2	18.6	19.3	20.3	21.9	23.2	24.9	27.6	30.2	35.8	42.8	52.1	
28	18.6	19.0	19.5	20.2	21.2	22.9	24.2	26.0	28.7	31.4	37.2	44.4	54.1	
29	19.5	19.9	20.4	21.0	22.1	23.8	25.2	27.1	29.9	32.6	38.6	46.1	56.1	
30	20.3	20.7	21.2	21.9	23.1	24.8	26.2	28.1	31.0	33.8	40.0	47.7	58.1	
31	21.2	21.6	22.1	22.8	24.0	25.8	27.2	29.2	32.1	35.1	41.5	49.4	60.1	
32	22.0	22.5	23.0	23.7	24.9	26.7	28.2	30.2	33.3	36.3	42.9	51.1	62.1	
33	22.9	23.3	23.9	24.6	25.8	27.7	29.3	31.3	34.4	37.5	44.3	52.7	64.1	
34	23.8	24.2	24.8	25.5	26.8	28.7	30.3	32.4	35.6	38.8	45.7	54.4	66.1	
35	24.6	25.1	25.6	26.4	27.7	29.7	31.3	33.4	36.7	40.0	47.1	56.0	68.1	
36	25.5	26.0	26.5	27.3	28.6	30.7	32.3	34.5	37.9	41.2	48.6	57.7	70.1	
37	26.4	26.8	27.4	28.3	29.6	31.6	33.3	35.6	39.0	42.4	50.0	59.4	72.1	
38	27.3	27.7	28.3	29.2	30.5	32.6	34.4	36.6	40.2	43.7	51.4	61.0	74.1	
39	28.1	28.6	29.2	30.1	31.5	33.6	35.4	37.7	41.3	44.9	52.8	62.7	76.1	
40	29.0	29.5	30.1	31.0	32.4	34.6	36.4	38.8	42.5	46.1	54.2	64.4	78.1	
41	29.9	30.4	31.0	31.9	33.4	35.6	37.4	39.9	43.6	47.4	55.7	66.0	80.1	
42	30.8	31.3	31.9	32.8	34.3	36.6	38.4	40.9	44.8	48.6	57.1	67.7	82.1	
43	31.7	32.2	32.8	33.8	35.3	37.6	39.5	42.0	45.9	49.9	58.5	69.3	84.1	
44	32.5	33.1	33.7	34.7	36.2	38.6	40.5	43.1	47.1	51.1	59.9	71.0	86.1	
45	33.4	34.0	34.6	35.6	37.2	39.6	41.5	44.2	48.2	52.3	61.3	72.7	88.1	
46	34.3	34.9	35.6	36.5	38.1	40.5	42.6	45.2	49.4	53.6	62.8	74.3	90.1	
47	35.2	35.8	36.5	37.5	39.1	41.5	43.6	46.3	50.6	54.8	64.2	76.0	92.1	
48	36.1	36.7	37.4	38.4	40.0	42.5	44.6	47.4	51.7	56.0	65.6	77.7	94.1	
49	37.0	37.6	38.3	39.3	41.0	43.5	45.7	48.5	52.9	57.3	67.0	79.3	96.1	
50	37.9	38.5	39.2	40.3	41.9	44.5	46.7	49.6	54.0	58.5	68.5	81.0	98.1	
N	1.0%	1.2%	1.5%	2%	3%	5%	7%	10%	15%	20%	30%	40%	50%	
	B													

**Table B.1** (Continued)

(Offered Load)		A in Erlangs												
n	$P_B$													
	0.01%	0.02%	0.03%	0.05%	0.1%	0.2%	0.3%	0.4%	0.5%	0.6%	0.7%	0.8%	0.9%	
50	28.9	29.9	30.5	31.3	32.5	33.9	34.8	35.4	36.0	36.5	36.9	37.2	37.6	
51	29.6	30.6	31.3	32.1	33.3	34.7	35.6	36.3	36.9	37.3	37.8	38.1	38.5	
52	30.4	31.4	32.0	32.9	34.2	35.6	36.5	37.2	37.7	38.2	38.6	29.0	39.4	
53	31.2	32.2	32.8	33.7	35.0	36.4	37.3	38.0	38.6	39.1	39.5	39.9	40.3	
54	31.9	33.0	33.6	34.5	35.8	37.2	38.2	38.9	39.5	40.0	40.4	40.8	41.2	
55	32.7	33.8	34.4	35.3	36.6	38.1	39.0	39.8	40.4	40.9	41.3	41.7	42.1	
56	33.5	34.6	35.2	36.1	37.5	38.9	39.9	40.6	41.2	41.7	42.2	42.6	43.0	
57	34.3	35.4	36.0	36.9	38.3	39.8	40.8	41.5	42.1	42.6	43.1	43.5	43.9	
58	35.1	36.2	36.8	37.8	39.1	40.6	41.6	42.4	43.0	43.5	44.0	44.4	44.8	
59	35.8	37.0	37.6	38.6	40.0	41.5	42.5	43.3	43.9	44.4	44.9	45.3	45.7	
60	36.6	37.8	38.5	39.4	40.8	42.4	43.4	44.1	44.8	45.3	45.8	46.2	46.6	
61	37.4	38.6	39.3	40.2	41.6	43.2	44.2	45.0	45.6	46.2	46.7	47.1	47.5	
62	38.2	39.4	40.1	41.0	42.5	44.1	45.1	45.9	46.5	47.1	47.6	48.0	48.4	
63	39.0	40.2	40.9	41.9	43.3	44.9	46.0	46.8	47.4	48.0	48.5	48.9	49.3	
64	39.8	41.0	41.7	42.7	44.2	45.8	46.8	47.6	48.3	48.9	49.4	49.8	50.2	
65	40.6	41.8	42.5	43.5	45.0	46.6	47.7	48.5	49.2	49.8	50.3	50.7	51.1	
66	41.4	42.6	43.3	44.4	45.8	47.5	48.6	49.4	50.1	50.7	51.2	51.6	52.0	
67	42.2	43.4	44.2	45.2	46.7	48.4	49.5	50.3	51.0	51.6	52.1	52.5	53.0	
68	43.0	44.2	45.0	46.0	47.5	49.2	50.3	51.2	51.9	52.5	53.0	53.4	53.9	
69	43.8	45.0	45.8	46.8	48.4	50.1	51.2	52.1	52.8	53.4	53.9	54.4	54.8	
70	44.6	45.8	46.6	47.7	49.2	51.0	52.1	53.0	53.7	54.3	54.8	55.3	55.7	
71	45.4	46.7	47.5	48.5	50.1	51.8	53.0	53.8	54.6	55.2	55.7	56.2	56.6	
72	46.2	47.5	48.3	49.4	50.9	52.7	53.9	54.7	55.5	56.1	56.6	57.1	57.5	
73	47.0	48.3	49.1	50.2	51.8	53.6	54.7	55.6	56.4	57.0	57.5	58.0	58.5	
74	47.8	49.1	49.9	51.0	52.7	54.5	55.6	56.5	57.3	57.9	58.4	58.9	59.4	
75	48.6	49.9	50.8	51.9	53.5	55.3	56.5	57.4	58.2	58.8	59.3	59.8	60.3	
76	49.4	50.8	51.6	52.7	54.4	56.2	57.4	58.3	59.1	59.7	60.3	60.8	61.2	
77	50.2	51.6	52.4	53.6	55.2	57.1	58.3	59.2	60.0	60.6	61.2	61.7	62.1	
78	51.1	52.4	53.3	54.4	56.1	58.0	59.2	60.1	60.9	61.5	62.1	62.6	63.1	
79	51.9	53.2	54.1	55.3	56.9	58.8	60.1	61.0	61.8	62.4	63.0	63.5	64.0	
80	52.7	54.1	54.9	56.1	57.8	59.7	61.0	61.9	62.7	63.3	63.9	64.4	64.9	
81	53.5	54.9	55.8	56.9	58.7	60.6	61.8	62.8	63.6	64.2	64.8	65.4	65.8	
82	54.3	55.7	56.6	57.8	59.5	61.5	62.7	63.7	64.5	65.2	65.7	66.3	66.8	
83	55.1	56.6	57.5	58.6	60.4	62.4	63.6	64.6	65.4	66.1	66.7	67.2	67.7	
84	56.0	57.4	58.3	59.5	61.3	63.2	64.5	65.5	66.3	67.0	67.6	68.1	68.6	
85	56.8	58.2	59.1	60.4	62.1	64.1	65.4	66.4	67.2	67.9	68.5	69.1	69.6	
86	57.6	59.1	60.0	61.2	63.0	65.0	66.3	67.3	68.1	68.8	69.4	70.0	70.5	
87	58.4	59.9	60.8	62.1	63.9	65.9	67.2	68.2	69.0	69.7	70.3	70.9	71.4	
88	59.3	60.8	61.7	62.9	64.7	66.8	68.1	69.1	69.9	70.6	71.3	71.8	72.3	
89	60.1	61.6	62.5	63.8	65.6	67.7	69.0	70.0	70.8	71.6	72.2	72.8	73.3	
90	60.9	62.4	63.4	64.6	66.5	68.6	69.9	70.9	71.8	72.5	73.1	73.7	74.2	
91	61.8	63.3	64.2	65.5	67.4	69.4	70.8	71.8	72.7	73.4	74.0	74.6	75.1	
92	62.6	64.1	65.1	66.3	68.2	70.3	71.7	72.7	73.6	74.3	75.0	75.5	76.1	
93	63.4	65.0	65.9	67.2	69.1	71.2	72.6	73.6	74.5	75.2	75.9	76.5	77.0	
94	64.2	65.8	66.8	68.1	70.0	72.1	73.5	74.5	75.4	76.2	76.8	77.4	77.9	
95	65.1	66.6	67.6	68.9	70.9	73.0	74.4	75.5	76.3	77.1	77.7	78.3	78.9	
96	65.9	67.5	68.5	69.8	71.7	73.9	75.3	76.4	77.2	78.0	78.7	79.3	79.8	
97	66.8	68.3	69.3	70.7	72.6	74.8	76.2	77.3	78.2	78.9	79.6	80.2	80.7	
98	67.6	69.2	70.2	71.5	73.5	75.7	77.1	78.2	79.1	79.8	80.5	81.1	81.7	
99	68.4	70.0	71.0	72.4	74.4	76.6	78.0	79.1	80.0	80.8	81.4	82.0	82.6	
100	69.3	70.9	71.9	73.2	75.2	77.5	78.9	80.0	80.9	81.7	82.4	83.0	83.5	
N	0.01%	0.02%	0.03%	0.05%	0.1%	0.2%	0.3%	0.4%	0.5%	0.6%	0.7%	0.8%	0.9%	
	B													

**Table B.1** (Continued)

(Offered Load)		A in Erlangs												
n	$P_B$													
	1.0%	1.2%	1.5%	2%	3%	5%	7%	10%	15%	20%	30%	40%	50%	
50	37.9	38.5	39.2	40.3	41.9	44.5	46.7	49.6	54.0	58.5	68.5	81.0	98.1	
51	38.8	39.4	40.1	41.2	42.9	45.5	47.7	50.6	55.2	59.7	69.9	82.7	100.1	
52	39.7	40.3	41.0	42.1	43.9	46.5	48.8	51.7	56.3	61.0	71.3	84.3	102.1	
53	40.6	41.2	42.0	43.1	44.8	47.5	49.8	52.8	57.5	62.2	72.7	86.0	104.1	
54	41.5	42.1	42.9	44.0	45.8	48.5	50.8	53.9	58.7	63.5	74.2	87.6	106.1	
55	42.4	43.0	43.8	44.9	46.7	49.5	51.9	55.0	59.8	64.7	75.6	89.3	108.1	
56	43.3	43.9	44.7	45.9	47.7	50.5	52.9	56.1	61.0	65.9	77.0	91.0	110.1	
57	44.2	44.8	45.7	46.8	48.7	51.5	53.9	57.1	62.1	67.2	78.4	92.6	112.1	
58	45.1	45.8	46.6	47.8	49.6	52.6	55.0	58.2	63.3	68.4	79.8	94.3	114.1	
59	46.0	46.7	47.5	48.7	50.6	53.6	56.0	59.3	64.5	69.7	81.3	96.0	116.1	
60	46.9	47.6	48.4	49.6	51.6	54.6	57.1	60.4	65.6	70.9	82.7	97.6	118.1	
61	47.9	48.5	49.4	50.6	52.5	55.6	58.1	61.5	66.8	72.1	84.1	99.3	120.1	
62	48.8	49.4	50.3	51.5	53.5	56.6	59.1	62.6	68.0	73.4	85.5	101.0	122.1	
63	49.7	50.4	51.2	52.5	54.5	57.6	60.2	63.7	69.1	74.6	87.0	102.6	124.1	
64	50.6	51.3	52.2	53.4	55.4	58.6	61.2	64.8	70.3	75.9	88.4	104.3	126.1	
65	51.5	52.2	53.1	54.4	56.4	59.6	62.3	65.8	71.4	77.1	89.8	106.0	128.1	
66	52.4	53.1	54.0	55.3	57.4	60.6	63.3	66.9	72.6	78.3	91.2	107.6	130.1	
67	53.4	54.1	55.0	56.3	58.4	61.6	64.4	68.0	73.8	79.6	92.7	109.3	132.1	
68	54.3	55.0	55.9	57.2	59.3	62.6	65.4	69.1	74.9	80.8	94.1	111.0	134.1	
69	55.2	55.9	56.9	58.2	60.3	63.7	66.4	70.2	76.1	82.1	95.5	112.6	136.1	
70	56.1	56.8	57.8	59.1	61.3	64.7	67.5	71.3	77.3	83.3	96.9	114.3	138.1	
71	57.0	57.8	58.7	60.1	62.3	65.7	68.5	72.4	78.4	84.6	98.4	115.9	140.1	
72	58.0	58.7	59.7	61.0	63.2	66.7	69.6	73.5	79.6	85.8	99.8	117.6	142.1	
73	58.9	59.6	60.6	62.0	64.2	67.7	70.6	74.6	80.8	87.0	101.2	119.3	144.1	
74	59.8	60.6	61.6	62.9	65.2	68.7	71.7	75.6	81.9	88.3	102.7	120.9	146.1	
75	60.7	61.5	62.5	63.9	66.2	69.7	72.7	76.7	83.1	89.5	104.1	122.6	148.0	
76	61.7	62.4	63.4	64.9	67.2	70.8	73.8	77.8	84.2	90.8	105.5	124.3	150.0	
77	62.6	63.4	64.4	65.8	68.1	71.8	74.8	78.9	85.4	92.0	106.9	125.9	152.0	
78	63.5	64.3	65.3	66.8	69.1	72.8	75.9	80.0	86.6	93.3	108.4	127.6	154.0	
79	64.4	65.2	66.3	67.7	70.1	73.8	76.9	81.1	87.7	94.5	109.8	129.3	156.0	
80	65.4	66.2	67.2	68.7	71.1	74.8	78.0	82.2	88.9	95.7	111.2	130.9	158.0	
81	66.3	67.1	68.2	69.6	72.1	75.8	79.0	83.3	90.1	97.0	112.6	132.6	160.0	
82	67.2	68.0	69.1	70.6	73.0	76.9	80.1	84.4	91.2	98.2	114.1	134.3	162.0	
83	68.2	69.0	70.1	71.6	74.0	77.9	81.1	85.5	92.4	99.5	115.5	135.9	164.0	
84	69.1	69.9	71.0	72.5	75.0	78.9	82.2	86.6	93.6	100.7	116.9	137.6	166.0	
85	70.0	70.9	71.9	73.5	76.0	79.9	83.2	87.7	94.7	102.0	118.3	139.3	168.0	
86	70.9	71.8	72.9	74.5	77.0	80.9	84.3	88.8	95.9	103.2	119.8	140.9	170.0	
87	71.9	72.7	73.8	75.4	78.0	82.0	85.3	89.9	97.1	104.5	121.2	142.6	172.0	
88	72.8	73.7	74.8	76.4	78.9	83.0	86.4	91.0	98.2	105.7	122.6	144.3	174.0	
89	73.7	74.6	75.7	77.3	79.9	84.0	87.4	92.1	99.4	106.9	124.0	145.9	176.0	
90	74.7	75.6	76.7	78.3	80.9	85.0	88.5	93.1	100.6	108.2	125.5	147.6	178.0	
91	75.6	76.5	77.6	79.3	81.9	86.0	89.5	94.2	101.7	109.4	126.9	149.3	180.0	
92	76.6	77.4	78.6	80.2	82.9	87.1	90.6	95.3	102.9	110.7	128.3	150.9	182.0	
93	77.5	78.4	79.6	81.2	83.9	88.1	91.6	96.4	104.1	111.9	129.7	152.6	184.0	
94	78.4	79.3	80.5	82.2	84.9	89.1	92.7	97.5	105.3	113.2	131.2	154.3	186.0	
95	79.4	80.3	81.5	83.1	85.8	90.1	93.7	98.6	106.4	114.4	132.6	155.9	188.0	
96	80.3	81.2	82.4	84.1	86.8	91.1	94.8	99.7	107.6	115.7	134.0	157.6	190.0	
97	81.2	82.2	83.4	85.1	87.8	92.2	95.8	100.8	108.8	116.9	135.5	159.3	192.0	
98	82.2	83.1	84.3	86.0	88.8	93.2	96.9	101.9	109.9	118.2	136.9	160.9	194.0	
99	83.1	84.1	85.3	87.0	89.8	94.2	97.9	103.0	111.1	119.4	138.3	162.6	196.0	
100	84.1	85.0	86.2	88.0	90.8	95.2	99.0	104.1	112.3	120.6	139.7	164.3	198.0	
	1.0%	1.2%	1.5%	2%	3%	5%	7%	10%	15%	20%	30%	40%	50%	
N	B													

Table B.1 (Continued)

(Offered Load)		A in Erlangs													
n	$P_B$														
	0.01%	0.02%	0.03%	0.05%	0.1%	0.2%	0.3%	0.4%	0.5%	0.6%	0.7%	0.8%	0.9%		
100	69.3	70.9	71.9	73.2	75.2	77.5	78.9	80.0	80.9	81.7	82.4	83.0	83.5		
102	70.9	72.6	73.6	75.0	77.0	79.3	80.7	81.8	82.7	83.5	84.2	84.8	85.4		
104	72.6	74.3	75.3	76.7	78.8	81.1	82.5	83.7	84.6	85.4	86.1	86.7	87.3		
106	74.3	76.0	77.1	78.5	80.5	82.8	84.3	85.5	86.4	87.2	87.9	88.6	89.2		
108	76.0	77.7	78.8	80.2	82.3	84.6	86.2	87.3	88.3	89.1	89.8	90.5	91.1		
110	77.7	79.4	80.5	81.9	84.1	86.4	88.0	89.2	90.1	90.9	91.7	92.3	92.9		
112	79.4	81.1	82.2	83.7	85.8	88.3	89.8	91.0	92.0	92.8	93.5	94.2	94.8		
114	81.1	82.9	84.0	85.4	87.6	90.1	91.6	92.8	93.8	94.7	95.4	96.1	96.7		
116	82.8	84.6	85.7	87.2	89.4	91.9	93.5	94.7	95.7	96.5	97.3	98.0	98.6		
118	84.5	86.3	87.4	89.0	91.2	93.7	95.3	96.5	97.5	98.4	99.2	99.9	100.5		
120	86.2	88.0	89.2	90.7	93.0	95.5	97.1	98.4	99.4	100.3	101.0	101.7	102.4		
122	87.9	89.8	90.9	92.5	94.7	97.3	98.9	100.2	101.2	102.1	102.9	103.6	104.3		
124	89.6	91.5	92.7	94.2	96.5	99.1	100.8	102.1	103.1	104.0	104.8	105.5	106.2		
126	91.3	93.2	94.4	96.0	98.3	100.9	102.6	103.9	105.0	105.9	106.7	107.4	108.1		
128	93.1	95.0	96.2	97.8	100.1	102.7	104.5	105.8	106.8	107.7	108.5	109.3	109.9		
130	94.8	96.7	97.9	99.5	101.9	104.6	106.3	107.6	108.7	109.6	110.4	111.2	111.8		
132	96.5	98.5	99.7	101.3	103.7	106.4	108.1	109.5	110.5	111.5	112.3	113.1	113.7		
134	98.2	100.2	101.4	103.1	105.5	108.2	110.0	111.3	112.4	113.4	114.2	115.0	115.6		
136	100.0	101.9	103.2	104.9	107.3	110.0	111.8	113.2	114.3	115.2	116.1	116.8	117.5		
138	101.7	103.7	105.0	106.6	109.1	111.9	113.7	115.0	116.2	117.1	118.0	118.7	119.4		
140	103.4	105.4	106.7	108.4	110.9	113.7	115.5	116.9	118.0	119.0	119.9	120.6	121.4		
142	105.1	107.2	108.5	110.2	112.7	115.5	117.4	118.7	119.9	120.9	121.8	122.5	123.3		
144	106.9	109.0	110.2	112.0	114.5	117.4	119.2	120.6	121.8	122.8	123.6	124.4	125.2		
146	108.6	110.7	112.0	113.8	116.3	119.2	121.1	122.5	123.6	124.6	125.5	126.3	127.1		
148	110.4	112.5	113.8	115.5	118.1	121.0	122.9	124.3	125.5	126.5	127.4	128.2	129.0		
150	112.1	114.2	115.6	117.3	119.9	122.9	124.8	126.2	127.4	128.4	129.3	130.1	130.9		
152	113.8	116.0	117.3	119.1	121.8	124.7	126.6	128.1	129.3	130.3	131.2	132.0	132.8		
154	115.6	117.8	119.1	120.9	123.6	126.5	128.5	129.9	131.2	132.2	133.1	133.9	134.7		
156	117.3	119.5	120.9	122.7	125.4	128.4	130.3	131.8	133.0	134.1	135.0	135.9	136.6		
158	119.1	121.3	122.7	124.5	127.2	130.2	132.2	133.7	134.9	136.0	136.9	137.8	138.5		
160	120.8	123.1	124.4	126.3	129.0	132.1	134.0	135.6	136.8	137.9	138.8	139.7	140.4		
162	122.6	124.8	126.2	128.1	130.8	133.9	135.9	137.4	138.7	139.8	140.7	141.6	142.4		
164	124.3	126.6	128.0	129.9	132.7	135.8	137.8	139.3	140.6	141.7	142.6	143.5	144.3		
166	126.1	128.4	129.8	131.7	134.5	137.6	139.6	141.2	142.5	143.5	144.5	145.4	146.2		
168	127.9	130.2	131.6	133.5	136.3	139.4	141.5	143.1	144.3	145.4	146.4	147.3	148.1		
170	129.6	131.9	133.4	135.3	138.1	141.3	143.4	144.9	146.2	147.3	148.3	149.2	150.0		
172	131.4	133.7	135.2	137.1	139.9	143.1	145.2	146.8	148.1	149.2	150.2	151.1	151.9		
174	133.1	135.5	136.9	138.9	141.8	145.0	147.1	148.7	150.0	151.1	152.1	153.0	153.9		
176	134.9	137.3	138.7	140.7	143.6	146.9	149.0	150.6	151.9	153.0	154.0	155.0	155.8		
178	136.7	139.0	140.5	142.5	145.4	148.7	150.8	152.4	153.8	154.9	156.0	156.9	157.7		
180	138.4	140.8	142.3	144.3	147.3	150.6	152.7	154.3	155.7	156.8	157.9	158.8	159.6		
182	140.2	142.6	144.1	146.1	149.1	152.4	154.6	156.2	157.6	158.7	159.8	160.7	161.6		
184	142.0	144.4	145.9	147.9	150.9	154.3	156.4	158.1	159.5	160.6	161.7	162.6	163.5		
186	143.7	146.2	147.7	149.8	152.8	156.1	158.3	160.0	161.4	162.5	163.6	164.5	165.4		
188	145.5	148.0	149.5	151.6	154.6	158.0	160.2	161.9	163.3	164.4	165.5	166.5	167.3		
190	147.3	149.8	151.3	153.4	156.4	159.8	162.1	163.8	165.2	166.4	167.4	168.4	169.3		
192	149.1	151.6	153.1	155.2	158.3	161.7	163.9	165.6	167.0	168.3	169.3	170.3	171.2		
194	150.8	153.4	154.9	157.0	160.1	163.6	165.8	167.5	168.9	170.2	171.2	172.2	173.1		
196	152.6	155.2	156.7	158.8	161.9	165.4	167.7	169.4	170.8	172.1	173.2	174.1	175.0		
198	154.4	156.9	158.5	160.7	163.8	167.3	169.6	171.3	172.7	174.0	175.1	176.1	177.0		
200	156.2	158.7	160.3	162.5	165.6	169.2	171.4	173.2	174.6	175.9	177.0	178.0	178.9		
	0.01%	0.02%	0.03%	0.05%	0.1%	0.2%	0.3%	0.4%	0.5%	0.6%	0.7%	0.8%	0.9%		
N	B														



**Table B.1** (Continued)

(Offered Load)		A in Erlangs												
n	$P_B$													
	1.0%	1.2%	1.5%	2%	3%	5%	7%	10%	15%	20%	30%	40%	50%	
100	84.1	85.0	86.2	88.0	90.8	95.2	99.0	104.1	112.3	120.6	139.7	164.3	198.0	
102	85.9	86.9	88.1	89.9	92.8	97.3	101.1	106.3	114.6	123.1	142.6	167.6	202.0	
104	87.8	88.8	90.1	91.9	94.8	99.3	103.2	108.5	116.9	125.6	145.4	170.9	206.0	
106	89.7	90.7	92.0	93.8	96.7	101.4	105.3	110.7	119.3	128.1	148.3	174.2	210.0	
108	91.6	92.6	93.9	95.7	98.7	103.4	107.4	112.9	121.6	130.6	151.1	177.6	214.0	
110	93.5	94.5	95.8	97.7	100.7	105.5	109.5	115.1	124.0	133.1	154.0	180.9	218.0	
112	95.4	96.4	97.7	99.6	102.7	107.5	111.7	117.3	126.3	135.6	156.9	184.2	222.0	
114	97.3	98.3	99.7	101.6	104.7	109.6	113.8	119.5	128.6	138.1	159.7	187.6	226.0	
116	99.2	100.2	101.6	103.5	106.7	111.7	115.9	121.7	131.0	140.6	162.6	190.9	230.0	
118	101.1	102.1	103.5	105.5	108.7	113.7	118.0	123.9	133.3	143.1	165.4	194.2	234.0	
120	103.0	104.0	105.4	107.4	110.7	115.8	120.1	126.1	135.7	145.6	168.3	197.6	238.0	
122	104.9	105.9	107.4	109.4	112.6	117.8	122.2	128.3	138.0	148.1	171.1	200.9	242.0	
124	106.8	107.9	109.3	111.3	114.6	119.9	124.4	130.5	140.3	150.6	174.0	204.2	246.0	
126	108.7	109.8	111.2	113.3	116.6	121.9	126.5	132.7	142.7	153.0	176.8	207.6	250.0	
128	110.6	111.7	113.2	115.2	118.6	124.0	128.6	134.9	145.0	155.5	179.7	210.9	254.0	
130	112.5	113.6	115.1	117.2	120.6	126.1	130.7	137.1	147.4	158.0	182.5	214.2	258.0	
132	114.4	115.5	117.0	119.1	122.6	128.1	132.8	139.3	149.7	160.5	185.4	217.6	262.0	
134	116.3	117.4	119.0	121.1	124.6	130.2	134.9	141.5	152.0	163.0	188.3	220.9	266.0	
136	118.2	119.4	120.9	123.1	126.6	132.3	137.1	143.7	154.4	165.5	191.1	224.2	270.0	
138	120.1	121.3	122.8	125.0	128.6	134.3	139.2	145.9	156.7	168.0	194.0	227.6	274.0	
140	122.0	123.2	124.8	127.0	130.6	136.4	141.3	148.1	159.1	170.5	196.8	230.9	278.0	
142	123.9	125.1	126.7	128.9	132.6	138.4	143.4	150.3	161.4	173.0	199.7	234.2	282.0	
144	125.8	127.0	128.6	130.9	134.6	140.5	145.6	152.5	163.8	175.5	202.5	237.6	286.0	
146	127.7	129.0	130.6	132.9	136.6	142.6	147.7	154.7	166.1	178.0	205.4	240.9	290.0	
148	129.7	130.9	132.5	134.8	138.6	144.6	149.8	156.9	168.5	180.5	208.2	244.2	294.0	
150	131.6	132.8	134.5	136.8	140.6	146.7	151.9	159.1	170.8	183.0	211.1	247.6	298.0	
152	133.5	134.8	136.4	138.8	142.6	148.8	154.0	161.3	173.1	185.5	214.0	250.9	302.0	
154	135.4	136.7	138.4	140.7	144.6	150.8	156.2	163.5	175.5	188.0	216.8	254.2	306.0	
156	137.3	138.6	140.3	142.7	146.6	152.9	158.3	165.7	177.8	190.5	219.7	257.6	310.0	
158	139.2	140.5	142.3	144.7	148.6	155.0	160.4	167.9	180.2	193.0	222.5	260.9	314.0	
160	141.2	142.5	144.2	146.6	150.6	157.0	162.5	170.2	182.5	195.5	225.4	264.2	318.0	
162	143.1	144.4	146.1	148.6	152.7	159.1	164.7	172.4	184.9	198.0	228.2	267.6	322.0	
164	145.0	146.3	148.1	150.6	154.7	161.2	166.8	174.6	187.2	200.4	231.1	270.9	326.0	
166	146.9	148.3	150.0	152.0	156.7	163.3	168.9	176.8	189.6	202.9	233.9	274.2	330.0	
168	148.9	150.2	152.0	154.5	158.7	165.3	171.0	179.0	191.9	205.4	236.8	277.6	334.0	
170	150.8	152.1	153.9	156.5	160.7	167.4	173.2	181.2	194.2	207.9	239.7	280.9	338.0	
172	152.7	154.1	155.9	158.5	162.7	169.5	175.3	183.4	196.6	210.4	242.5	284.2	342.0	
174	154.6	156.0	157.8	160.4	164.7	171.5	177.4	185.6	198.9	212.9	245.4	287.6	346.0	
176	156.6	158.0	159.8	162.4	166.7	173.6	179.6	187.8	201.3	215.4	248.2	290.9	350.0	
178	158.5	159.9	161.8	164.4	168.7	175.7	181.7	190.0	203.6	217.9	251.1	294.2	354.0	
180	160.4	161.8	163.7	166.4	170.7	177.8	183.8	192.2	206.0	220.4	253.9	297.5	358.0	
182	162.3	163.8	165.7	168.3	172.8	179.8	185.9	194.4	208.3	222.9	256.8	300.9	362.0	
184	164.3	165.7	167.6	170.3	174.8	181.9	188.1	196.6	210.7	225.4	259.6	304.2	366.0	
186	166.2	167.7	169.6	172.3	176.8	184.0	190.2	198.9	213.0	227.9	262.5	307.5	370.0	
188	168.1	169.6	171.5	174.3	178.8	186.1	192.3	201.1	215.4	230.4	265.4	310.9	374.0	
190	170.1	171.5	173.5	176.5	180.8	188.1	194.5	203.3	217.7	232.9	268.2	314.2	378.0	
192	172.0	173.5	175.4	178.2	182.8	190.2	196.6	205.5	220.1	235.4	271.1	317.5	382.0	
194	173.9	175.4	177.4	180.2	184.8	192.3	198.7	207.7	222.4	237.9	273.9	320.9	386.0	
196	175.9	177.4	179.4	182.2	186.9	194.4	200.8	209.9	224.8	240.4	276.8	324.2	390.0	
198	177.8	179.3	181.3	184.2	188.9	196.4	203.0	212.1	227.1	242.9	279.6	327.5	394.0	
200	179.7	181.3	183.3	186.2	190.9	198.5	205.1	214.3	229.4	245.4	282.5	330.9	398.0	
	1.0%	1.2%	1.5%	2%	3%	5%	7%	10%	15%	20%	30%	40%	50%	
N	B													

Table B.1 (Continued)

(Offered Load)		A in Erlangs												
n	$P_B$													
	0.01%	0.02%	0.03%	0.05%	0.1%	0.2%	0.3%	0.4%	0.5%	0.6%	0.7%	0.8%	0.9%	
200	156.2	158.7	160.3	162.5	165.6	169.2	171.4	173.2	174.6	175.9	177.0	178.0	178.9	
202	158.0	160.5	162.1	164.3	167.5	171.0	173.3	175.1	176.5	177.8	178.9	179.9	180.8	
204	159.7	162.3	164.0	166.1	169.3	172.9	175.2	177.0	178.4	179.7	180.8	181.8	182.8	
206	161.5	164.1	165.8	167.9	171.2	174.8	177.1	178.9	180.4	181.6	182.7	183.8	184.7	
208	163.3	165.9	167.6	169.8	173.0	176.6	179.0	180.8	182.3	183.5	184.7	185.7	186.6	
210	165.1	167.7	169.4	171.6	174.8	178.5	180.9	182.7	184.2	185.4	186.6	187.6	188.6	
212	166.9	169.5	171.2	173.4	176.7	180.4	182.7	184.6	186.1	187.4	188.5	189.5	190.5	
214	168.7	171.3	173.0	175.2	178.5	182.2	184.6	186.5	188.0	189.3	190.4	191.5	192.4	
216	170.5	173.2	174.8	177.1	180.4	184.1	186.5	188.4	189.9	191.2	192.3	193.4	194.4	
218	172.3	175.0	176.6	178.9	182.2	186.0	188.4	190.2	191.8	193.1	194.3	195.3	196.3	
220	174.0	176.8	178.5	180.7	184.1	187.8	190.3	192.1	193.7	195.0	196.2	197.2	198.2	
222	175.8	178.6	180.3	182.6	185.9	189.7	192.2	194.0	195.6	196.9	198.1	199.2	200.2	
224	177.6	180.4	182.1	184.4	187.8	191.6	194.1	195.9	197.5	198.8	200.0	201.1	202.1	
226	179.4	182.2	183.9	186.2	189.6	193.5	195.9	197.8	199.4	200.8	202.0	203.0	204.0	
228	181.2	184.0	185.7	188.1	191.5	195.3	197.8	199.7	201.3	202.7	203.9	205.0	206.0	
230	183.0	185.8	187.6	189.9	193.3	197.2	199.7	201.6	203.2	204.6	205.8	206.9	207.9	
232	184.8	187.6	189.4	191.7	195.2	199.1	201.6	203.5	205.1	206.5	207.7	208.8	209.8	
234	186.6	189.4	191.2	193.6	197.1	201.0	203.5	205.4	207.1	208.4	209.7	210.8	211.8	
236	188.4	191.3	193.0	195.4	198.9	202.8	205.4	207.4	209.0	210.4	211.6	212.7	213.7	
238	190.2	193.1	194.9	197.2	200.8	204.7	207.3	209.3	210.9	212.3	213.5	214.6	215.7	
240	192.0	194.9	196.7	199.1	202.6	206.6	209.2	211.2	212.8	214.2	215.4	216.6	217.6	
242	193.8	196.7	198.5	200.9	204.5	208.5	211.1	213.1	214.7	216.1	217.4	218.5	219.5	
244	195.6	198.5	200.3	202.8	206.3	210.4	213.0	215.0	216.6	218.0	219.3	220.4	221.5	
246	197.4	200.3	202.2	204.6	208.2	212.2	214.9	216.9	218.5	220.0	221.2	222.4	223.4	
248	199.2	202.2	204.0	206.4	210.1	214.1	216.8	218.8	220.4	221.9	223.2	224.3	225.4	
250	201.0	204.0	205.8	208.3	211.9	216.0	218.7	220.7	222.4	223.8	225.1	226.2	227.3	
	0.908	0.914	0.920	0.926	0.934	0.944	0.950	0.956	0.960	0.964	0.968	0.972	0.974	
300	246.4	249.7	251.8	254.6	258.6	263.2	266.2	268.5	270.4	272.0	273.5	274.8	276.0	
	0.918	0.924	0.928	0.932	0.942	0.952	0.958	0.962	0.966	0.970	0.972	0.976	0.978	
350	292.3	295.9	298.2	301.2	305.7	310.8	314.1	316.6	318.7	320.5	322.1	323.6	324.9	
	0.922	0.928	0.932	0.938	0.946	0.954	0.960	0.966	0.970	0.972	0.976	0.978	0.982	
400	338.4	342.3	344.8	348.1	353.0	358.5	362.1	364.9	367.2	369.1	370.9	372.5	374.0	
	0.928	0.934	0.938	0.942	0.950	0.958	0.964	0.968	0.972	0.976	0.978	0.982	0.984	
450	384.8	389.0	391.7	395.2	400.5	406.4	410.3	413.3	415.8	417.9	419.8	421.6	423.2	
	0.932	0.938	0.942	0.946	0.954	0.962	0.968	0.972	0.974	0.978	0.982	0.982	0.984	
500	431.4	435.9	438.8	442.5	448.2	454.5	458.7	461.9	464.5	466.8	468.9	470.7	472.4	
	0.938	0.943	0.946	0.951	0.957	0.965	0.970	0.974	0.978	0.981	0.983	0.986	0.989	
600	525.2	530.2	533.4	537.6	543.9	551.0	555.7	559.3	562.3	564.9	567.2	569.3	571.3	
	0.943	0.948	0.951	0.956	0.962	0.969	0.974	0.978	0.981	0.984	0.986	0.989	0.990	
700	619.5	625.0	628.5	633.2	640.1	647.9	653.1	657.1	660.4	663.3	665.8	668.2	670.3	
	0.948	0.953	0.955	0.959	0.965	0.972	0.976	0.980	0.983	0.985	0.989	0.990	0.993	
800	714.3	720.3	724.0	729.1	736.6	745.1	750.7	755.1	758.7	761.8	764.7	767.2	769.6	
	0.951	0.955	0.959	0.962	0.967	0.974	0.979	0.982	0.985	0.988	0.990	0.993	0.994	
900	809.4	815.8	819.9	825.3	833.3	842.5	848.6	853.3	857.2	860.6	863.7	866.5	869.0	
	0.954	0.959	0.961	0.964	0.970	0.976	0.980	0.984	0.987	0.989	0.991	0.993	0.996	
1000	904.8	911.7	916.0	921.7	930.3	940.1	946.6	951.7	955.9	959.5	962.8	965.8	968.6	
	0.962	0.963	0.960	0.963	0.977	0.979	0.984	0.983	0.991	0.995	0.992	0.992	0.994	
1100	1001.	1008.	1012.	1018.	1028.	1038.	1045.	1050.	1055.	1059.	1062.	1065.	1068.	
N	0.01%	0.02%	0.03%	0.05%	0.1%	0.2%	0.3%	0.4%	0.5%	0.6%	0.7%	0.8%	0.9%	
	B													

**Table B.1** (Continued)

<i>n</i>	(Offered Load)													
	A in Erlangs													
	$P_B$													
	1.0%	1.2%	1.5%	2%	3%	5%	7%	10%	15%	20%	30%	40%	50%	
200	179.7	181.3	183.3	186.2	190.9	198.5	205.1	214.3	229.4	245.4	282.5	330.9	398.0	
202	181.7	183.2	185.2	188.1	192.9	200.6	207.2	216.5	231.8	247.9	285.4	334.2	402.0	
204	183.6	185.2	187.2	190.1	194.9	202.7	209.4	218.7	234.1	250.4	288.2	337.5	406.0	
206	185.5	187.1	189.2	192.1	196.9	204.7	211.5	221.0	236.5	252.9	291.1	340.9	410.0	
208	187.5	189.1	191.1	194.1	199.0	206.8	213.6	223.2	238.8	255.4	293.9	344.2	414.0	
210	189.4	191.0	193.1	196.1	201.0	208.9	215.8	225.4	241.2	257.9	296.8	347.5	418.0	
212	191.4	193.0	195.1	198.1	203.0	211.0	217.9	227.6	243.5	260.4	299.6	350.9	422.0	
214	193.3	194.9	197.0	200.0	205.0	213.0	220.0	229.8	245.9	262.9	302.5	354.2	426.0	
216	195.2	196.9	199.0	202.0	207.0	215.1	222.2	232.0	248.2	265.4	305.3	357.5	430.0	
218	197.2	198.8	201.0	204.0	209.1	217.2	224.3	234.2	250.6	267.9	308.2	360.9	434.0	
220	199.1	200.8	202.9	206.0	211.1	219.3	226.4	236.4	252.9	270.4	311.1	364.2	438.0	
222	201.1	202.7	204.9	208.0	213.1	221.4	228.6	238.6	255.3	272.9	313.9	367.5	442.0	
224	203.0	204.7	206.8	210.0	215.1	223.4	230.7	240.9	257.6	275.4	316.8	370.9	446.0	
226	204.9	206.6	208.8	212.0	217.1	225.5	232.8	243.1	260.0	277.8	319.6	374.2	450.0	
228	206.9	208.6	210.8	213.9	219.2	227.6	235.0	245.3	262.3	280.3	322.5	377.5	454.0	
230	208.8	210.5	212.8	215.9	221.2	229.7	237.1	247.5	264.7	282.8	325.3	380.9	458.0	
232	210.8	212.5	214.7	217.9	223.2	231.8	239.2	249.7	267.0	285.3	328.2	384.2	462.0	
234	212.7	214.4	216.7	219.9	225.2	233.8	241.4	251.9	269.4	287.8	331.1	387.5	466.0	
236	214.7	216.4	218.7	221.9	227.2	235.9	243.5	254.1	271.7	290.3	333.9	390.9	470.0	
238	216.6	218.3	220.6	223.9	229.3	238.0	245.6	256.3	274.1	292.8	336.8	394.2	474.0	
240	218.6	220.3	222.6	225.9	231.3	240.1	247.8	258.6	276.4	295.3	339.6	397.5	478.0	
242	220.5	222.3	224.6	227.9	233.3	242.2	249.9	260.8	278.8	297.8	342.5	400.9	482.0	
244	222.5	224.2	226.5	229.9	235.3	244.3	252.0	263.0	281.1	300.3	345.3	404.2	486.0	
246	224.4	226.2	228.5	231.8	237.4	246.3	254.2	265.2	283.4	302.8	348.2	407.5	490.0	
248	226.3	228.1	230.5	233.8	239.4	248.4	256.3	267.4	285.8	305.3	351.0	410.9	494.0	
250	228.3	230.1	232.5	235.8	241.4	250.5	258.4	269.6	288.1	307.8	353.9	414.2	498.0	
	0.976	0.982	0.988	0.998	1.014	1.042	1.070	1.108	1.176	1.250	1.428	1.666	2.000	
300	277.1	279.2	281.9	285.7	292.1	302.6	311.9	325.0	346.9	370.3	425.3	497.5	598.0	
	0.982	0.984	0.990	1.000	1.016	1.044	1.070	1.108	1.174	1.248	1.428	1.668	2.000	
350	326.2	328.4	331.4	335.7	342.9	354.8	365.4	380.4	405.6	432.7	496.7	580.9	698.0	
	0.982	0.988	0.994	1.004	1.020	1.046	1.070	1.108	1.176	1.250	1.430	1.666	2.000	
400	375.3	377.8	381.1	385.9	393.9	407.1	418.9	435.8	464.4	495.2	568.2	664.2	798.0	
	0.986	0.990	0.996	1.004	1.018	1.046	1.072	1.110	1.176	1.250	1.428	1.666	2.000	
450	424.6	427.3	430.9	436.1	444.8	459.4	472.5	491.3	523.2	557.7	639.6	747.5	898.0	
	0.988	0.994	0.998	1.006	1.022	1.048	1.070	1.108	1.176	1.250	1.428	1.668	2.000	
500	474.0	477.0	480.8	486.4	495.9	511.8	526.0	546.7	582.0	620.2	711.0	830.9	998.0	
	0.991	0.994	1.000	1.008	1.022	1.047	1.073	1.110	1.176	1.249	1.429	1.666	2.000	
600	573.1	576.4	580.8	587.2	598.1	616.5	633.3	657.7	699.6	745.1	853.9	997.5	1198.	
	0.993	0.997	1.002	1.010	1.024	1.049	1.073	1.110	1.176	1.250	1.428	1.665	2.00	
700	672.4	676.1	681.0	688.2	700.5	721.4	740.6	768.7	817.2	870.1	996.7	1164.	1398.	
	0.994	0.998	1.004	1.011	1.025	1.050	1.073	1.110	1.176	1.250	1.433	1.67	2.00	
800	771.8	775.9	781.4	789.3	803.0	826.4	847.9	879.7	934.8	995.1	1140.	1331.	1598.	
	0.997	1.000	1.004	1.013	1.025	1.050	1.074	1.111	1.172	1.249	1.42	1.67	2.00	
900	871.5	875.9	881.8	890.6	905.5	931.4	955.3	990.8	1052.	1120.	1282.	1498.	1798.	
	0.997	1.001	1.006	1.013	1.025	1.046	1.077	1.112	1.18	1.25	1.43	1.66	2.00	
1000	971.2	976.0	982.4	991.9	1008.	1036.	1063.	1102.	1170.	1245.	1425.	1664.	1998.	
	0.998	1.000	1.006	1.011	1.03	1.05	1.07	1.11	1.18	1.25	1.43	1.67	2.00	
1100	1071.	1076.	1083.	1093.	1111.	1141.	1170.	1213.	1288.	1370.	1568.	1831.	2198.	
N	1.0%	1.2%	1.5%	2%	3%	5%	7%	10%	15%	20%	30%	40%	50%	
	B													

## ***Appendix C: Abbreviations***

A/D	Analogue to Digital
ACPM	Amplitude Companded Phase Modulation
ACSSB	Amplitude Companded Single Sideband
ADM	Adaptive Delta Modulation
ADPCM	Adaptive Differential Pulse Code Modulation
AFC	Automatic Frequency Control
AGC	Automatic Gain Control
AM	Amplitude Modulation
AMPS	Advanced Mobile Phone System
APC	Automatic Power Control
APK	Amplitude and Phase Shift Keying
ASK	Amplitude Shift Keying
AWGN	Additive White Gaussian Noise
BCC	Blocked Calls Cleared
BCD	Blocked Calls Delayed
BER	Bit Error Rate
BPF	Bandpass Filter
BPSK	Binary Phase Shift Keying
BW	Bandwidth
CCIR	International Radio Consultative Committee
CCITT	International Telegraph and Telephone Consultative Committee
CDMA	Code Division Multiple Access
CP-FSK	Continuous Phase Frequency Shift Keying
dB	Decibel
DE-PSK	Differentially Encoded Phase Shift Keying
DM	Delta Modulation
DPCM	Differential Pulse Code Modulation
DPSK	Differential Phase Shift Keying
DQPSK	Differential Quadrature Phase Shift Keying
DS	Direct Sequence

DSB	Double-Sideband
DSB-SC	Double-Sideband Suppressed Carrier
DTI	Department of Trade and Industry
E	Erlangs
FCC	Federal Communications Commission
FDMA	Frequency Division Multiple Access
FFH	Fast Frequency Hopping
FH	Frequency Hopping
FM	Frequency Modulation
FSK	Frequency Shift Keying
GMSK	Gaussian Minimum Shift Keying
GSM	Groupe Spécial Mobile or Global System for Mobile Communication
ISDN	Integrated System Digital Network
kbps	Kilo Bits per Second
LPF	Lowpass Filter
MOS	Mean Opinion Score
MSK	Minimum Shift Keying
NAMTS	Nippon Advanced Mobile Telephone System
NB-TDMA	Narrowband Time Division Multiple Access
NBFM	Narrowband Frequency Modulation
NTIA	National Telecommunication and Information Agency
OOK	On–Off Keying
PCM	Pulse Code Modulation
PCN	Personal Communication Networks
PDF	Probability Density Function
PM	Phase Modulation
psd	Power Spectral Density
PSK	Phase Shift Keying
QAM	Quadrature Amplitude Modulation
QPR	Quadrature Partial Response
QPSK	Quadrature Phase Shift Keying
RF	Radio Frequency
RRD	Radio Regulatory Division
Rx	Receiver
SCPC	Single Channel per Carrier
SFH	Slow Frequency Hopping

SINAD	Signal+Noise+Distortion to Noise+Distortion
SNR	Signal to Noise Ratio
SSB	Single-Sideband
SSB-SC	Single-Sideband Suppressed Carrier
SSMA	Spread Spectrum Multiple Access
TACS	Total Access Cellular System
TDMA	Time Division Multiple Access
TH	Time Hopping
Tx	Transmitter
UMTS	Universal Mobile Telecommunications System
VLSI	Very Large Scale Integration
WB-TDMA	Wideband Time Division Multiple Access
WBFM	Wideband Frequency Modulation

## Appendix D: List of Symbols

$(S/N)_o$	Signal to noise power ratio at the receiver output
$A$	Cell area
$a$	Protection ratio
$B_b$	Baseband channel spacing
$B_c$	Voice channel spacing
$B_{c,T}$	Effective channel spacing
$B_t$	Total bandwidth
$B_T$	Transmission bandwidth
$B_u$	Bandwidth which a user can access during its time slot
$C$	Shannon capacity
$D$	Minimum co-channel cell separation
$E_b/N_o$	Average signal energy per bit to noise spectral density
$E\{x\}$	Denotes the average of $x$
$f$	Frequency
$F_b$	Bit rate
$f_c$	Carrier frequency
$f_m$	Message signal bandwidth
$f_s$	Sampling rate
$f_{\Delta}$	Peak frequency deviation
$G_{Bi}$	Interfering base station antenna gain
$G_{Bs}$	Serving base station antenna gain
$G_M$	Mobile station antenna gain
$G_R$	Gain of the receiver antenna
$G_T$	Gain of the transmitter antenna
$h$	Modulation index
$h_{Bi}$	Interfering base station antenna height
$h_{Bs}$	Serving base station antenna height
$h_M$	Mobile station antenna height
$I$	Unwanted co-channel interfering signal power
$I_t$	Interference power from a cell in the $t$ th tier in a cellular system
$k$	Constant representing the attenuation caused by the channel

$k_f$	Frequency deviation constant expressed in rad/s/V
$k_p$	Phase deviation constant expressed in rad/V
$M_a$	Total number of voice channels available to the cellular system
$m_I(t)$	In-phase binary data signal
$m_i(t)$	Input message signal
$m_o(t)$	Output message signal
$m_Q(t)$	Quadrature binary data signal
$M_t$	Number of time slots dedicated for voice transmission in a frame
$M_u$	Number of users sharing the same time slot with different frequency bands
$m_x$	Modulation index for AM
$N$	Noise power
$n(t)$	Narrowband or bandpass AWGN
$N_c$	Number of cells per cluster
$n_c(t)$	In-phase, lowpass AWGN component
$n_o(t)$	Noise at the output of the system
$N_s$	Total inband noise power in the system
$n_s(t)$	Quadrature, lowpass AWGN component
$n$	Number of Traffic Channels
$p(y)$	Probability density function of $y$
$P_B$	Blocking probability
$P_c$	Average carrier signal power
$P_m$	Average message signal power
$P_R$	Recovered signal power
$P_T$	Transmitted signal power
$Q$	Co-channel re-use ratio
$R$	Cell radius
$S$	Wanted signal power
$S/N$	Signal to noise ratio (SNR)
$T$	Frame duration
$t$	Time
$T_b$	Symbol duration
$t_d$	Constant representing the time delay caused by the channel
$v(t)$	Instantaneous amplitude of the carrier
$w$	Angular frequency, in rad/s
$W_i$	Power transmitted by the interfering base station



$W_s$	Power transmitted by the serving base station
$\alpha$	Propagation constant
$\beta$	Deviation ratio for FM
$\gamma$	Equivalent average signal to noise ratio for analogue baseband transmission
$\eta_C$	Overall spectral efficiency in Channels/MHz/km <sup>2</sup>
$\eta_E$	Overall spectral efficiency in Erlangs/MHz/km <sup>2</sup>
$\eta_M$	Modulation efficiency of a cellular system in Channels/MHz/km <sup>2</sup>
$\eta_R$	Relative spectral efficiency
$\eta_T$	Multiple access efficiency factor
$\eta_U$	Overall spectral efficiency in Users/MHz/km <sup>2</sup>
$\lambda$	Wavelength
$\sigma$	Standard deviation
$\mu$	Power efficiency of AM
$\tau$	Time slot duration
$\tau_g$	Guard time
$\phi(t)$	Instantaneous phase deviation of the carrier