

# [A Practical Guide to 'Free Energy' Devices](#)

Part D16: Last updated: 7th November 2007

Author: Patrick J. Kelly

## **A Suggested Electrolyzer Design**

**The material presented here is for information purposes only. Experimenting with hydrogen and/or a mixture of hydrogen and oxygen is highly dangerous and you do so entirely at your own risk. Neither Patrick Kelly nor any other person connected with the preparation or display of this material recommends that you to do so and they disclaim any responsibility should you decide to do so against their advice.**

The electrolyzer cell design shown here is based on a proposed design by Frank Roberts of the Yahoo Group "watercar". This modified version of his cell is combined with an electronic circuit which has performed well for Dave Lawton. This document is only a suggestion for a system which may perform very well but which has not yet been built or tried since Stanley Meyer's time. A major advantage of this cell is that it uses ordinary tap water. An advantage of this style of construction is that the water in the cell covers the electrode plates, which allows easy topping up of the water and a considerable volume of water to be used before topping up is necessary.

The cell can contain three separate, identical sets of 20 electrode plates each, though the number in each set can be varied up or down if you so choose. The plate size is suggested to be 6 inches (150 mm) square, and it is important that these are made from 316L-grade stainless steel. The gap between adjacent plates in each group is 0.039 inches (1 mm) and the applied voltage comes from an extra alternator mounted in the vehicle. What is very different about this design is that the stator coil of the alternator is driven by a highly-variable waveform, generated by the electronics.

The thickness of the stainless steel plates is not important, so long as they are thick enough to be sufficiently rigid to stay in position during use. A suggested thickness is 22 gauge steel (0.031 inches or 0.8 mm thick). The container is made from acrylic sheet. This is sometimes sold under the trade names of "Plexiglas" or "Lexan". An alternative type of plastic is "Vivak". Frank suggests 1/4 inch (6 mm) thick sheet with aluminium angle at the corners, and the bolt heads bedded in silicon compound inside the case, as shown in the photographs in this document.

It should be noted that shiny new stainless steel is **not** suitable for use as an electrode in any form of electrolysis. When the power is first applied, very little electrolysis takes place in the tap water, as the active surfaces of the plates get covered with bubbles which stick to them. The electrode plates should be prepared for use by cleaning them carefully to remove any grease and then cross-scoring the whole of both surfaces with coarse sandpaper. The objective in this process is to create tiny sharp-crested hills on the surface of the plate. This increases the surface area and the sharp crests act as focus points for individual bubbles to form. After sanding, the plates are cleaned again with a solvent and then rinsed off with distilled water. After this preparation, the plates are assembled into their groups and it is advisable to wear clean rubber gloves when doing this, so as to avoid getting finger marks on the working surfaces of the plates.

When the cell has been assembled, the plates need to be "conditioned". In this system which uses tap water, the conditioning consists of applying power to the plates for five minutes or so, and then leaving the plates to sit for a couple of hours. This procedure is repeated as often as possible for two or three days. It is thought that what is happening in this process is that hydrogen gets absorbed into the structure of the steel plates during the 'resting' periods and this changes the nature of the surface of the plates. After some time of doing this, the rate of electrolysis suddenly increases to a far greater level than before, although the electrical drive has not altered in any way. The rate of gas production from tap water shown in Dave Lawton's video of his Stanley Meyer Replication Water Fuel Cell which can be seen at the web site <http://www.icubenetwork.com/files/watercar/non-commercial/dave/videos/Wfcrep.WMV> is using conditioned pipe electrodes and that rate of gas production would not happen with new electrodes which have not been conditioned.

In this design, the electrical connections to the plates are made with bolts and washers. The output from the cell goes through a bubbler and then to commercial fuel injectors. The pressure inside the cell is maintained in the 40 to 45 pounds per square inch range as the fuel injectors require 40 psi. If injectors are not being used, then the pressure can be very much lower.

For running off water alone, it is recommended that you replace the vehicle's valves, sparkplugs and exhaust system with stainless steel versions. The fuel injectors are like standard fuel injectors except the injection opening is larger and they are provided with a special coating as, unlike a standard injector, these injectors do not need any fossil fuel lubrication. A source for these injectors is <http://www.gtww.com/products/afsch/injectors.php>.

Replacement water is pumped into the cell using a standard vehicle electric fuel pump, controlled by a water-level sensor circuit as shown here:

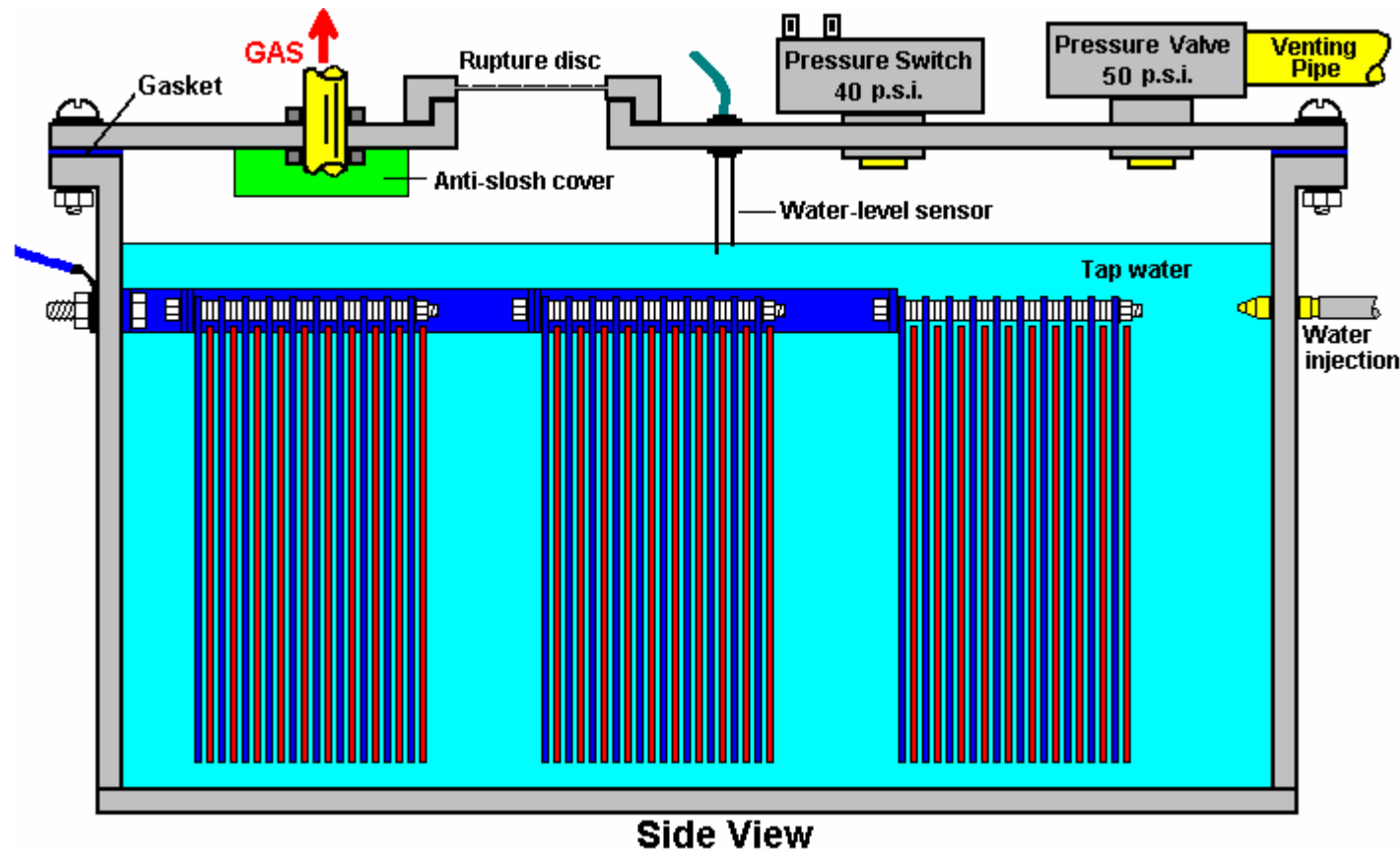

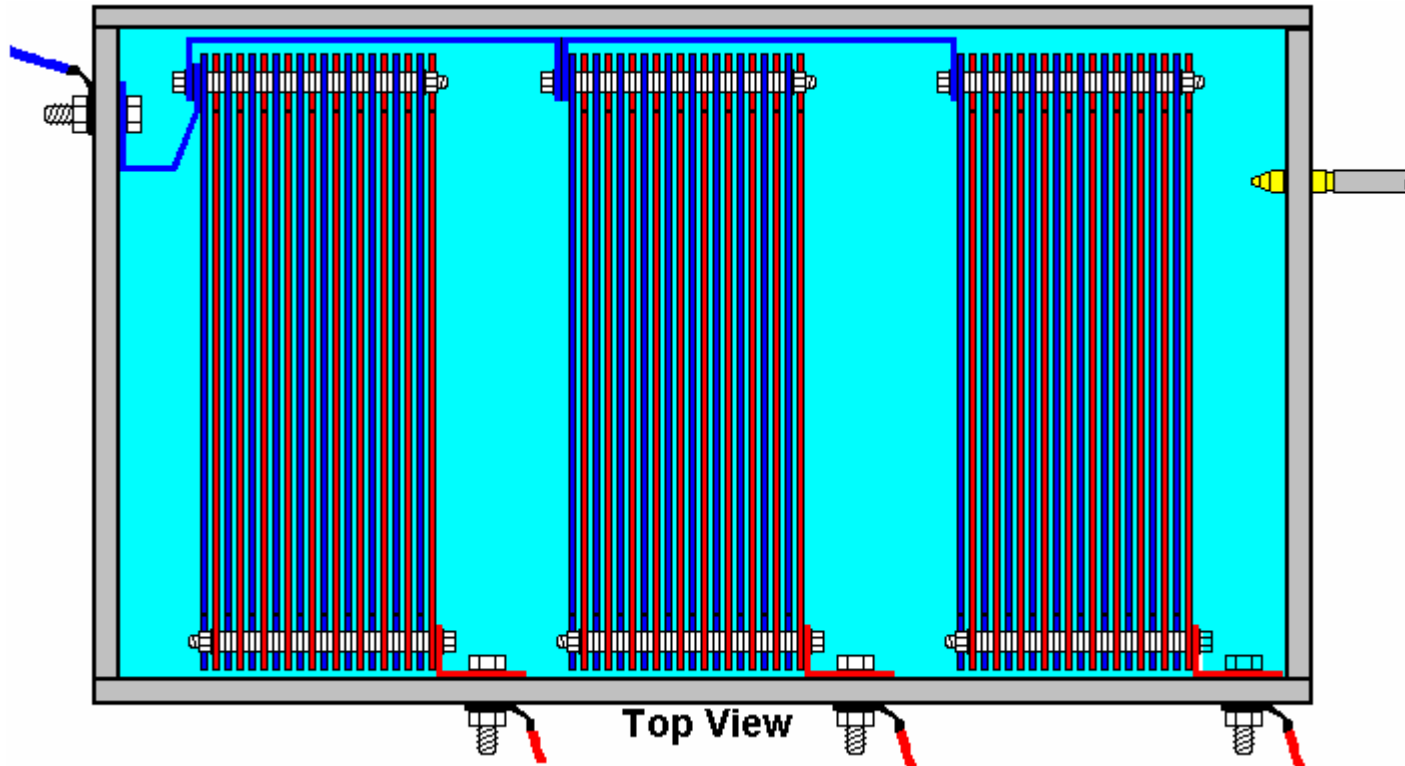

It should be noted that there is a quarter inch (6 mm) gap below the plates. This lets water be drawn up between the plates by the bubbles rising. The water sensor is placed in the middle of the unit so that it is not affected by the cell being tilted due to the vehicle going up a hill.

A pressure-activated stainless steel electrical switch is used to disconnect the electrical supply from the cell and prevent excessive pressure. It switches on at 40 psi and switches off at 45 psi. If, during normal operation, a pressure of 50 psi is reached, then an emergency situation has occurred. To deal with this, two safety devices are included. The first is a stainless

steel mechanical pressure-release valve which operates at 50 psi. If this is activated, it vents the gas safely outside the vehicle through a tube which prevents any gas being trapped inside the engine compartment. The second safety device is a rupture disc which breaks in 2 milliseconds and produces no dangerous fragments. It is made from a thin sheet of metal, scored in such a fashion as to make it break up at a pressure of 60 psi. In the most unlikely event of an accidental explosion in the cell the rupture disc would vent the explosion harmlessly.

It has been suggested that you use the coldest sparkplug you can find. This carries away the heat from the sparkplug tip into the engine block avoiding pre-ignition. Never, use a platinum-tip sparkplug as the platinum acts as a catalyst causing the hydrogen to combine with the oxygen on contact with the platinum. It is also suggested that good crankcase ventilation is maintained as some hydroxy gas will get past the rings and if it builds up in the crankcase it might possibly ignite, which is not a desirable event.

The fuel injection is between two and fifteen degrees after Top Dead Centre on the intake stroke. The spark is retarded to anything from 2 to 15 degrees after Top Dead Centre. Use tap water drawn from the hot tap as some of the added gasses are driven off by the heating system. It should be noted that the cell is a heavy unit due to all the steel and water in it, and it needs a robust mounting bracket to hold it securely to withstand the vibration and impacts of motoring use. This is the circuit of a suggested voltage pulser unit which uses an additional alternator mounted so that its shaft is rotated by the fan belt:

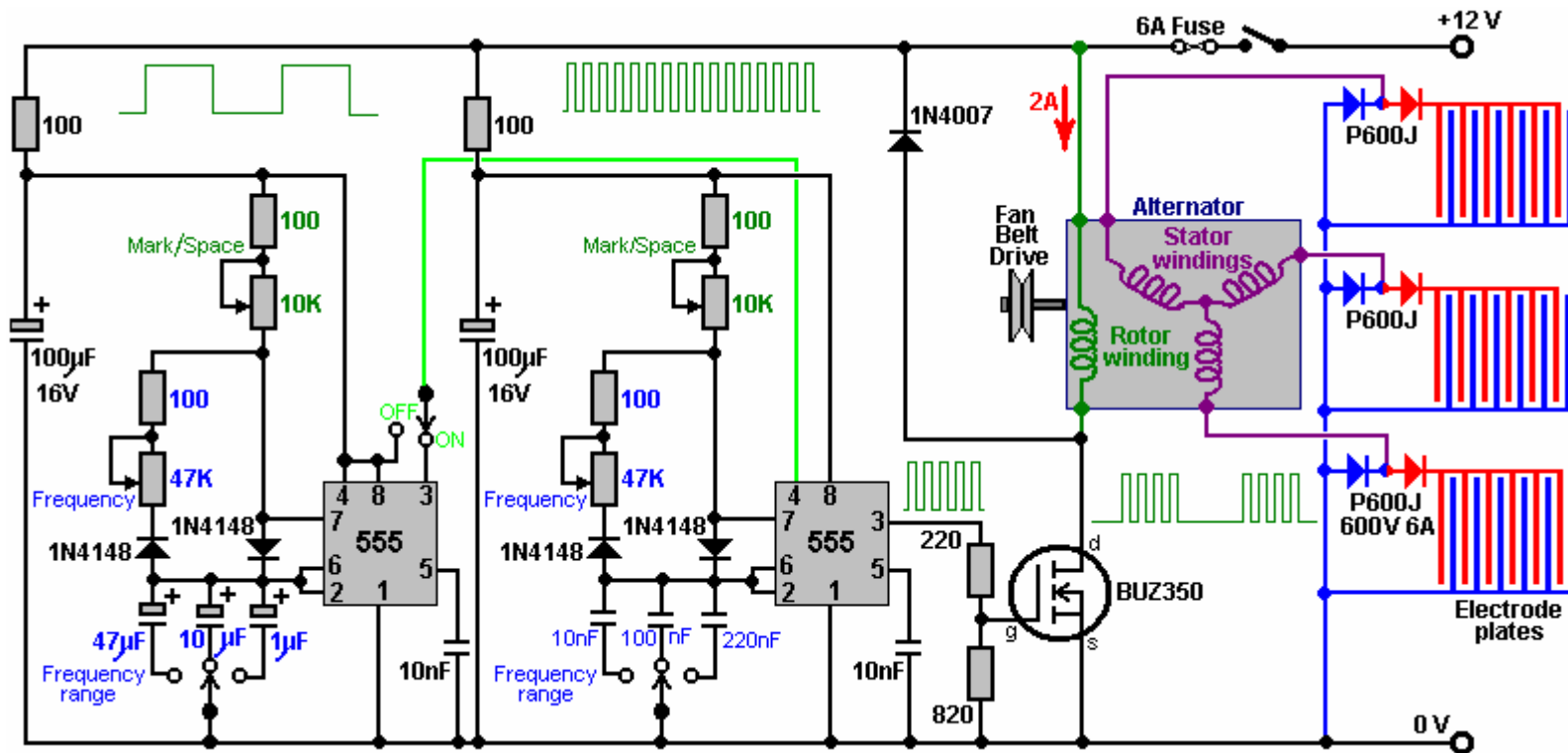

The advantage of this style of cell construction is that it can be taken apart quite readily for inspection or for modification, such as adding extra plates. The disadvantage is that the plates are just held by nuts and bolts and more importantly, the electrical connections to the plates inside the cell are via nuts and bolts. It must be remembered that the space above the water inside the unit will be filled with hydroxy gas which is an explosive mixture. It is therefore very important that no electrical connection inside the casing, comes loose and creates a spark which will ignite the gas. For that reason, the bolts should have locking nuts which are tightened hard down to lock the assembly. It would be no harm if the locking nuts were to be the anti-vibration type with plastic inserts which hold the bolt tightly.

### ***Circuit operation:***

Each NE555 timer chip is placed in an oscillator circuit which has both variable pulse rate (“frequency”) and variable Mark/Space ratio which does not affect the frequency. These oscillator circuits also have three frequency ranges which can be selected by a rotary switch. The variable resistors each have a 100 ohm resistor in series with them so that their combined resistance cannot fall below 100 ohms. Each oscillator circuit has its supply de-coupled by placing a 100 microfarad capacitor across the supply rails and feeding the capacitor through a 100 ohm resistor. This has the effect of reducing any pulsing being carried along the battery connections to affect the adjoining circuit.

The first NE555 circuit has fairly large capacitors which give it comparatively slow pulses, as represented by the waveform shown above it. The output from that NE555 is on pin 3 and can be switched to feed the waveform to pin 4 of the second NE555 timer. This gates the second, higher frequency oscillator On and Off to produce the output waveform shown just below the pipe electrodes. The switch at pin 3 of the first NE555 allows the gating to be switched off, which causes the output waveform to be just a straight square wave of variable frequency and Mark/Space ratio.

The output voltage from pin 3 of the second NE555 chip is reduced by the 220 ohm / 820 ohm resistor combination. The transistor acts as a current amplifier, capable of providing several amps to the electrodes. The 1N4007 diode is included to protect the MOSFET should it be decided at a later date to introduce either a coil (“inductor”) or a transformer in the output coming from the MOSFET, as sudden switching off of a current through either of these could briefly pull the ‘drain’ connection a long way below the 0 Volt line and damage the MOSFET, but the 1N4007 diode switches on and prevents this from happening by clamping the drain voltage to -0.7 volts if the drain is driven to a negative voltage.

The BUZ350 MOSFET has a current rating of 22 amps so it will run cool in this application. However, it is worth mounting it on an aluminium plate which will act both as the mounting and a heat sink. The current draw in this arrangement is particularly interesting. This circuit was used by Dave Lawton to drive cylindrical electrodes placed in tap water. With just one tube in place, the current draw was about one amp. When a second tube was added, the current increased by less than half an amp. When the third was added, the total current was under two amps. The fourth and fifth tubes added about 100 milliamps each and the sixth tube caused almost no increase in current at all.

Although the current is not particularly high, a six amp circuit-breaker, or fuse, should be placed between the power supply and the circuit, to protect against accidental short-circuits. It is **vital** that at least one bubbler is placed between the water-splitter and the engine, to give some protection if the gas should get ignited by an engine malfunction. It is also a good idea for the bubbler lid to be a tight push-fit so that it can pop off in the event of an explosion, and so further limit the effect of an accident.

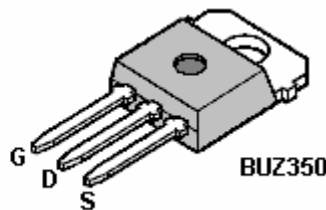
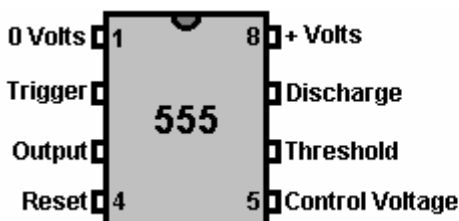

A possible component layout is shown here:

• = Track cut on underside of the board

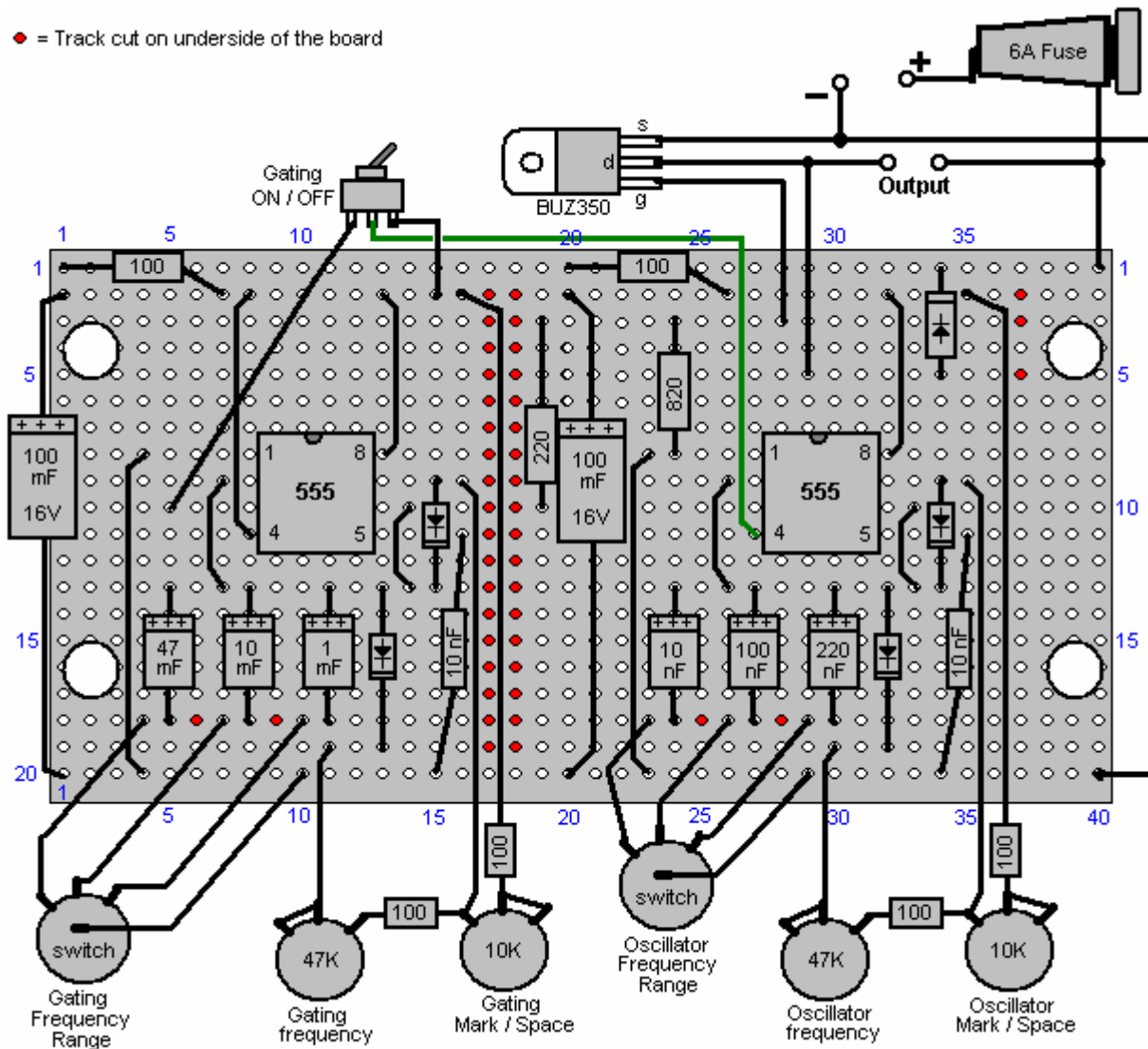

The underside of the stripboard is shown here:

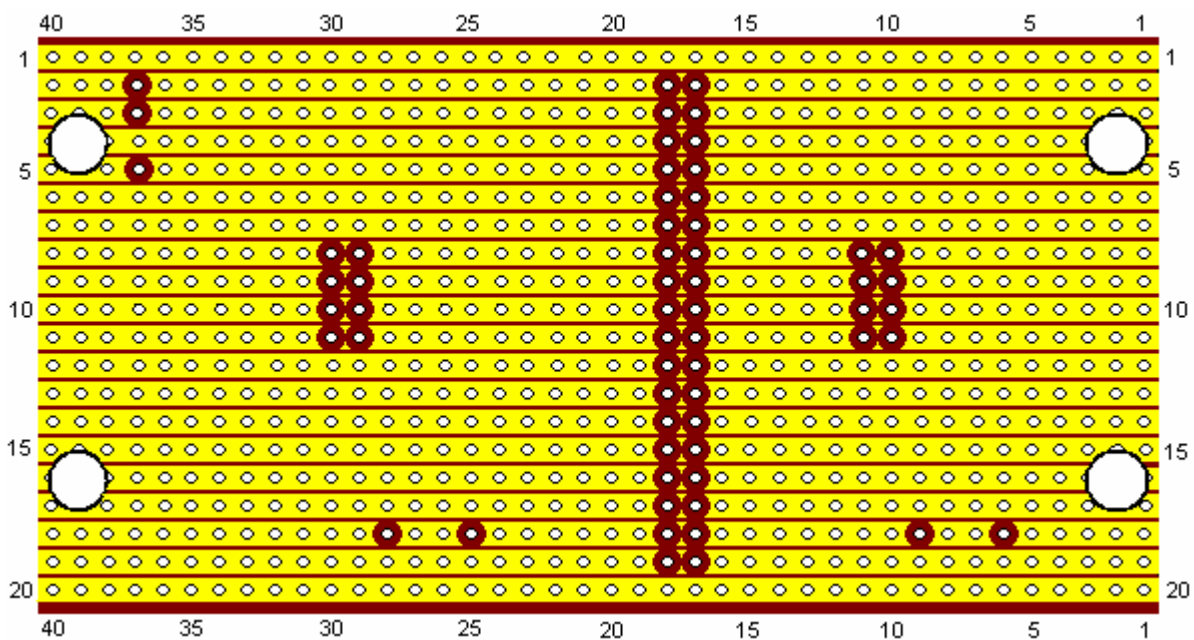

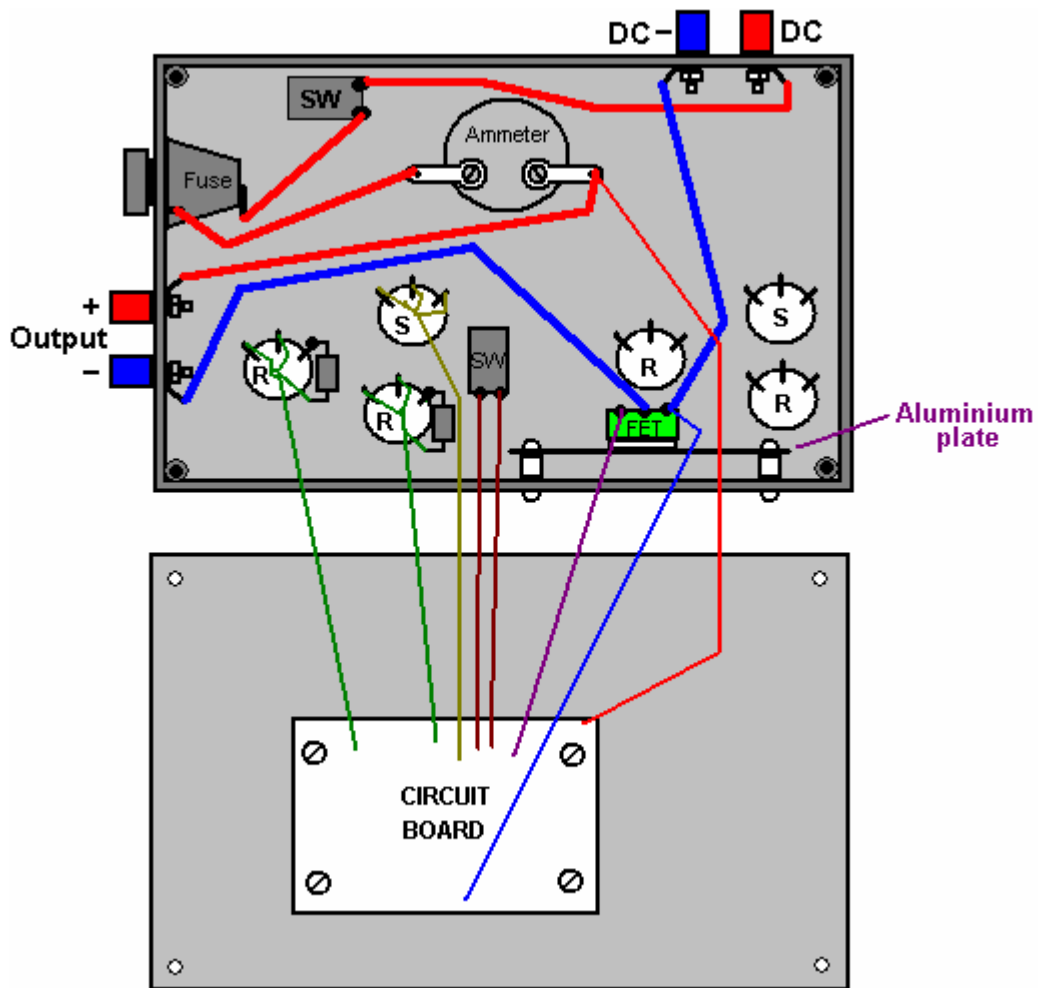

Component	Quantity	Description	Comment
100 ohm resistors 0.25 watt	6	Bands: Brown, Black, Brown	
220 ohm resistor 0.25 watt	1	Bands: Red, Red, Brown	
820 ohm resistor 0.25 watt	1	Bands: Gray, Red, Brown	
100 mF 16V capacitor	2	Electrolytic	
47mF 16V capacitor	1	Electrolytic	
10 mF 16V capacitor	1	Electrolytic	
1 mF 16 V capacitor	1	Electrolytic	
220 nF capacitor (0.22 mF)	1	Ceramic or polyester	
100 nF capacitor (0.1 mF)	1	Ceramic or polyester	
10 nF capacitor (0.01 mF)	3	Ceramic or polyester	
1N4148 diodes	4		
1N4007 diode	1		FET protection
P600J diodes	6	600V 6A for alternator output	(Not put on the board)
NE555 timer chip	2		
BUZ350 MOSFET	1	Or any 200V 20A n-channel MOSFET	
47K variable resistors	2	Standard carbon track	Could be screw track
10K variable resistors	2	Standard carbon track	Could be screw track
4-pole, 3-way switches	2	Wafer type	Frequency range
1-pole changeover switch	1	Toggle type, possibly sub-miniature	Any style will do
1-pole 1-throw switch	1	Toggle type rated at 10 amps	Overall ON / OFF switch
Fuse holder	1	Enclosed type or a 6A circuit breaker	Short-circuit protection
Veroboard	1	20 strips, 40 holes, 0.1 inch matrix	Parallel copper strips
8-pin DIL IC sockets	2	Black plastic, high or low profile	Protects the 555 ICs
Wire terminals	4	Ideally two red and two black	Power lead connectors
Plastic box	1	Injection moulded with screw-down lid	
Mounting nuts, bolts and pillars	8	Hardware for 8 insulated pillar mounts	For board and heatsink
Aluminium sheet	1	About 4 inch x 2 inch	MOSFET heatsink
Rubber or plastic feet	4	Any small adhesive feet	Underside of case
Knobs for variable resistors etc.	6	1/4 inch shaft, large diameter	Marked skirt variety
Ammeter	1	Optional item, 0 to 5A or similar	
Sundry connecting wire	4 m	Various sizes	

### Cell Assembly Suggestions

This is one of the easiest cell construction methods. The plates are all the same size (6 inch or 150 mm being the suggested size) and square in shape, although this is not a requirement. The method of construction is not critical. The plates should be tested with a magnet to confirm that they are genuinely Grade 316L steel as some supplies are not what they claim to be. A magnet should fall off a vertical steel surface, being unable to sustain it's own weight due to the lack of magnetic capability of the stainless steel.

One option for making sure that adjoining plates do not touch each other, is to drill each plate with an additional hole (or holes) and when the plates are being bolted together, and additional plastic bolt and plastic washers can be used to clamp the plates securely in position and space them correctly.

The weight of water and steel inside the cell is considerable. Frank recommends this style of construction which reinforces the joints in the plastic sheet with aluminium angle strip and stainless steel bolts as shown here, (although all joints should first be made with special adhesive supplied for use with acrylic):





Frank suggests cutting a triangle off the top corner of each electrode plate and drilling a hole in the opposite top corner. Every second plate is turned around so that the hole in it is positioned in the space left by the triangle removed from the plates on each side of it. So the electrical connections as shown here:

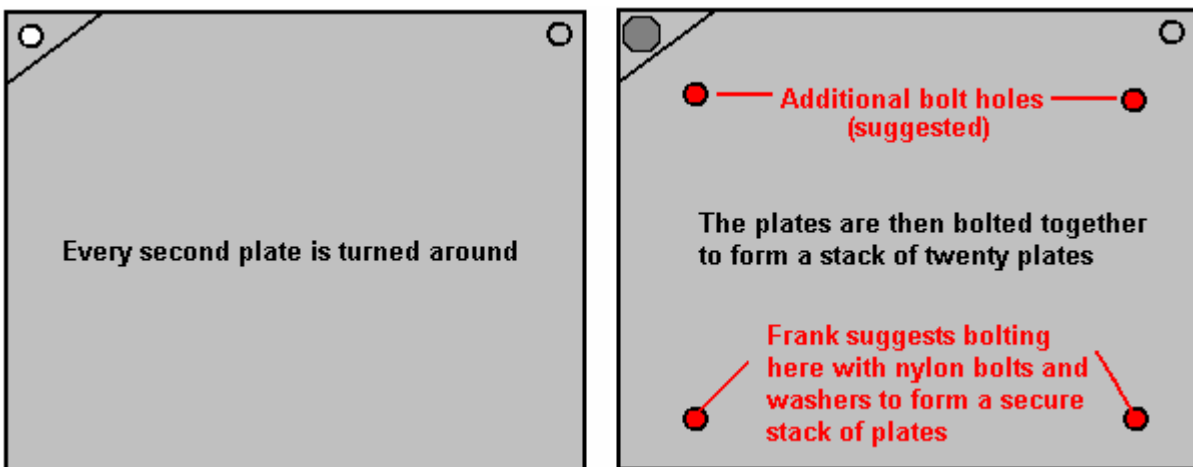
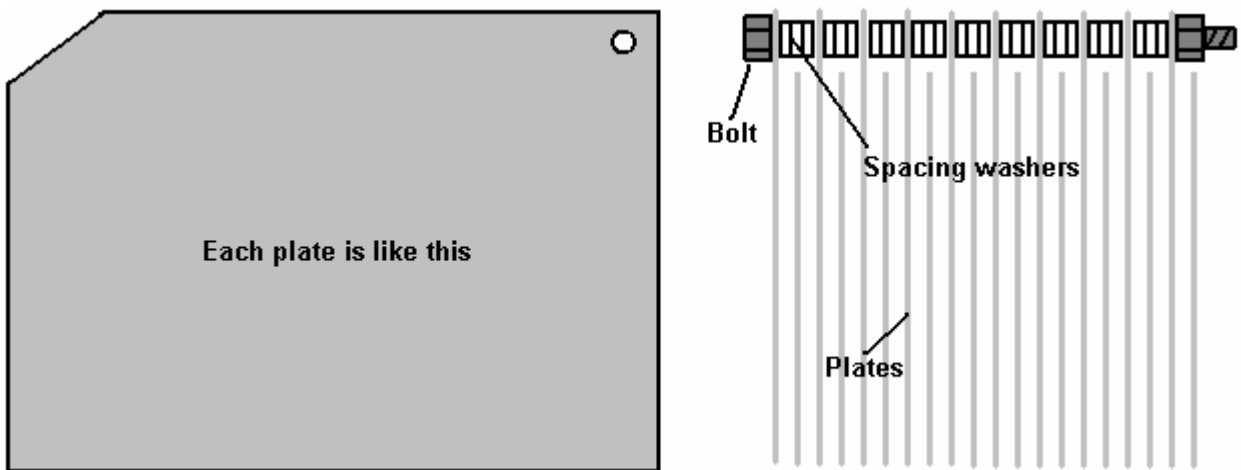

This style of construction makes it very easy to take the plates apart for inspection and cleaning, should that be considered to be desirable. The additional holes for the plastic bolts and plastic spacing washers have not been shown, but ideally, there should be at least two of these to provide a minimum of three mounting points per plate.

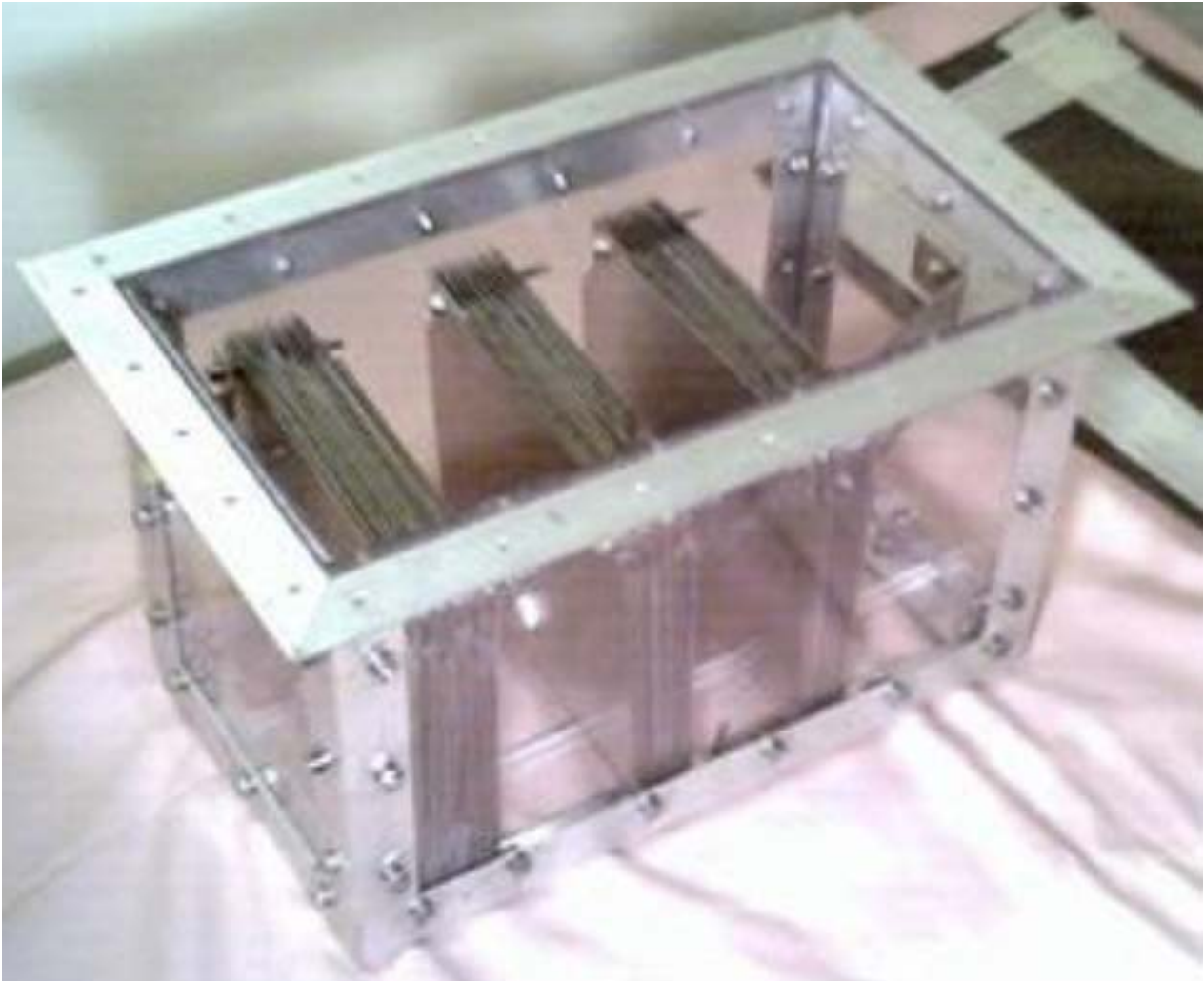

You will notice that the sets of plates are positioned inside the housing so that they avoid the heads of the bolts used to clamp the aluminium angle strips used to reinforce the cell. In the construction shown here, the sets of plates are not exactly centred inside the housing. This does not matter at all as there is adequate clearance between the sets and, of course, the internal volume is not altered in any way.

You will also note that underneath the plates there are two strips of plastic used to support the plates and keep the lower edges of the plates off the base of the cell. This gap allows water to flow up between the plates when the cell is operating, to replace the water displaced by the upward movement of thousands of tiny gas bubbles rising to the surface.

The electrical connections to the sets of plates are made with stainless steel straps as these act as mounting brackets to hold the plates in position as well as carrying the electrical current to the plates. The electrical current is low as this is a water-splitter and not a standard DC electrolyser which relies on high current to generate a large volume of gas.

The anti-slosh material, used to prevent water splashing up into the gas outlet pipe, can be the plastic matting used with aquariums. Plastic pot scrubbers have also been suggested as a good material for use in this position.

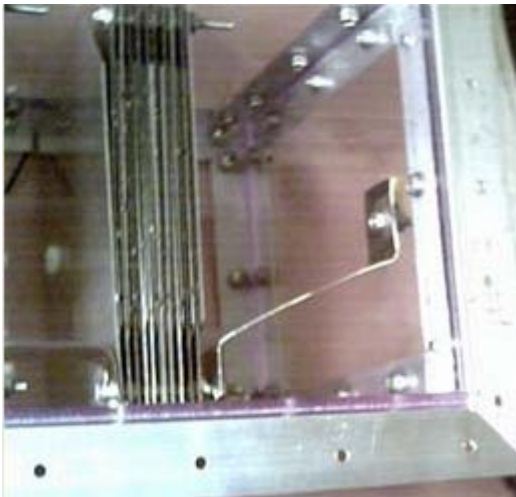
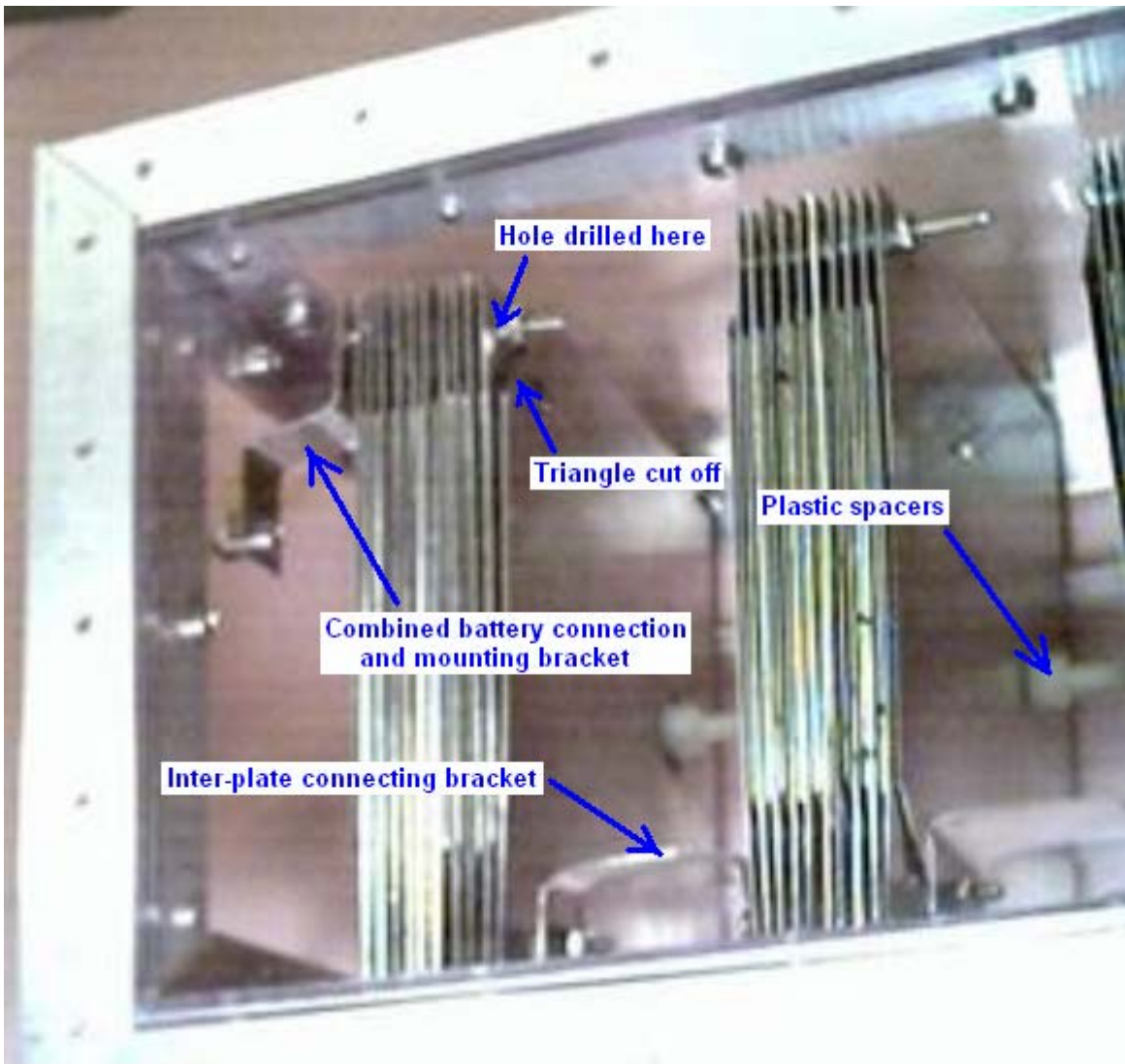

And positioned in the engine compartment:



As mentioned earlier, it is absolutely vital that every precaution be taken to avoid an explosion. The “hydroxy” gas produced by this cell is mainly hydrogen gas and oxygen gas which are already mixed together in the ideal proportions for them to recombine to form water again. That happens when the gasses are lit, and the flame front of the ignition is about 1,000 times faster than the flame front when petroleum vapour is ignited, so the standard flash-back protection devices just do not work. The best protection device is a ‘bubbler’ which is a simple, easily-made, container which feeds the gas up through a column of water as shown here:

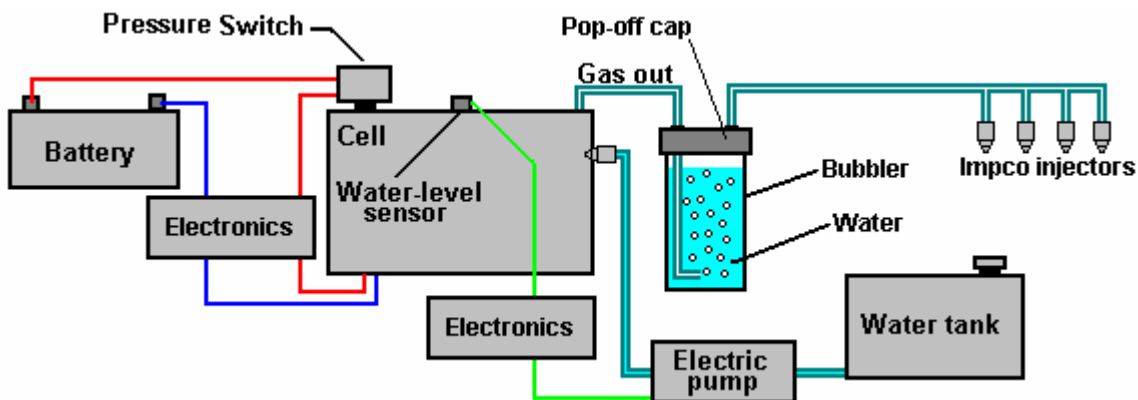

Ideally, a bubbler should have a tightly-fitting pop-off lid so that should the gas inside it be ignited, then the lid will be blown off instantly, robbing the explosion of its power. Some people like to place a one-way valve in the gas pipe between the cell and the bubbler to ensure that no sudden pressure is passed back to the cell.





patent is included in this set of documents and can be found at the [www.web-space.tv/free-energy](http://www.web-space.tv/free-energy) web site which usually needs the browser's Refresh button to get past a German-language advertisement page to reach the site.

### **Using the Cell:**

When operating this unit for the first time, start by switching off the first 555 timer which is used to create a "relaxation" gap between the sets of pulses generated by the second 555 timer circuit. Adjust the frequency of the second timer circuit and watch the rate of gas production. As the frequency rises, a point will be found where the gas production is markedly higher. If the frequency is raised further, the gas rate will drop off again until a higher frequency point is reached, when the same thing happens again. Dave Lawton found that with his Meyer style cell, the resonant points were around 3 KHz and 6 HKz.

Pick one of these points, and then switch in the first 555 timer. If this control is adjusted, a point will be found where the gas production rate increases even further. This is the point where the pulsing of the water in the cell stops just long enough for the water to be in its best state to be hit with another burst of pulses from the second timer.

If you wish, the first timer circuit can be used to reduce the gas rate by increasing the gap between bursts of pulses to such a degree that it hinders the breakdown of the water. In this situation, the cell is essentially switched off for part of every second and so it won't produce gas in the time it is switched off.

Generally speaking, the design of this cell envisages the electronics being adjusted to give the maximum gas output all the time, and the cell is powered down by the gas-pressure switch when gas generation exceeds the amount that the engine needs to run under it's current loading. It is expected that the gas produced by this cell will be mixed with air in a 20:1 ratio as only 4% of the intake to the engine need be hydroxy gas.

If this cell were used as a booster for an engine running on a fossil fuel, then if the vehicle is fitted with an ECU computer module, then the circuitry explained in the D17.pdf document which forms part of the set, will be needed to stop the computer injecting more fossil fuel than is needed.

### **Possible Modifications:**

The question must be asked, "are there any improvements which can be made?". The answer to that question is usually "yes" but it is seldom clear what actions might be taken to improve the situation. Here, we might consider the patent application US 2005/0246059 of Stan Meyer's brother Stephen in November 2005. In it, he uses a Water Fuel Cell with pipe electrodes, driven by an alternator, and the interesting thing is the way that he attempts to match the alternator output to the electrodes.

The arrangement is quite like the system already shown in this document, where two of the alternator phases are applied to each electrode set in turn:

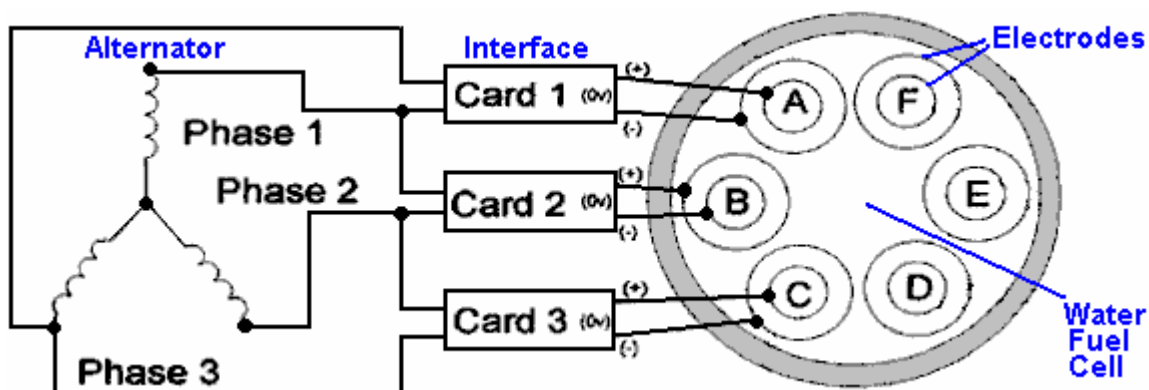

Stephen adds in an interface circuit between the alternator drive and the electrodes. The interface circuit is shown here:

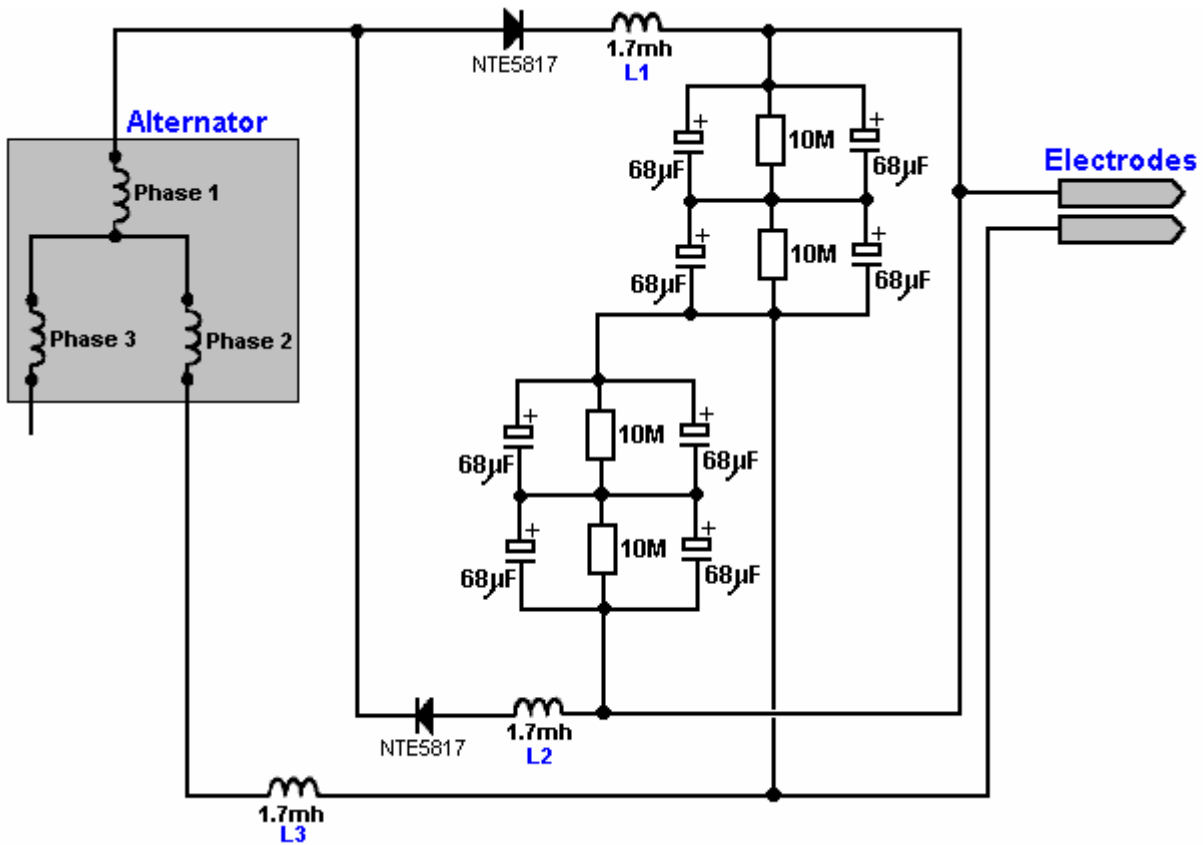

You will notice that three inductors (coils of wire on a core) are used in each of the three arms between the alternator and the electrodes. Stan talked about how important inductors were in this area of the circuit as he believed that the inductors allowed the cell to be tuned to give minimal current flow while giving maximum gas production. This sort of matching circuit is something which it might be worth trying out to see if the cell efficiency might be raised even further.

If you have difficulty understanding any of the electronic circuits in this document, you might find the Electronics Tutorial on web site [www.free-energy-info.co.uk](http://www.free-energy-info.co.uk) helpful.