

[A Practical Guide to 'Free Energy' Devices](#)

Part D18: Last updated: 27th November 2006

Author: Patrick J. Kelly

[A Different Fuel](#)

In the early days of heavier than air flight, observations were made and based on those observations, practical operating rules were deduced. After a time, those rules became called the "laws" of aerodynamics. These "laws" were applied to the design, building and use of aircraft and they were, and are, very useful.

One day it was observed that if you apply those laws of aerodynamics to bumble bees, then according to those laws, it was not possible for a bee to fly since there was just not enough lift generated to get the bee off the ground. But simple observation shows that bees do in fact fly and they can rise off the ground when they choose to do so.

Does that mean that the "laws" of aerodynamics are no good? Of course not, as they have been shown to be of great practical use when dealing with aircraft. What it did show was that the existing laws did not cover every instance, so research was done and the laws of aerodynamics were extended to include the equations for lift generated by turbulent flow. These show how a bee can develop enough lift to get off the ground. Do bees care about this? No, not at all, they just go on flying as before. What has changed is that the understanding of scientists and engineers has been extended to better fit the world around us.

Today, people who are trained in science and engineering are fed the idea that internal combustion engines need to consume a fossil fuel in order to operate. That is not strictly true and at the present time, engines using hydrogen gas as a fuel are becoming commonplace. Unfortunately, most of the hydrogen produced for this use, comes from fossil fuels, so these vehicles are still running on a fossil fuel, though only indirectly.

The "laws" of engineering say that it is not possible for an internal combustion engine to run without consuming some sort of fuel. Unfortunately, Josef Papp has demonstrated an internal combustion engine which has had it's intake and exhaust systems blanked off. Filled with a mixture of inert gasses, during one demonstration, that Volvo engine ran for half an hour, producing a measured 300 horsepower, and apparently consuming no fuel at all. Josef received US patent 3,680,432 for his engine and you can see a video of one of his engines running at <http://video.google.com/videoplay?docid=-2850891179207690407>. Robert Britt designed a similar sealed motor filled with a mixture of inert gasses, and he received US patent 3,977,191 for it.

Does this mean that the current laws of engineering are of no use? Certainly not, they are vital for everyday life today. What it does mean, however, is that the present laws need to be extended to include the effects shown by these engines.

Another thing widely accepted today is that an internal combustion engine can't use water as a fuel. Well.... let's leave that to one side for the moment and look at it from a slightly different angle. Engines can definitely run using air and hydrogen as the fuel, there is no argument about that as there are many vehicle around which do just that. If you pass a current through water, the water breaks up into hydrogen gas and oxygen gas, this mixture is called "hydroxy" gas and that can most definitely be used, along with air, as the fuel for an internal combustion engine. But... this gas came from water, so is it really correct to say that water cannot be used as the fuel for an internal combustion engine?

Ah, says somebody with relief, that is not the case, because you are using water **and** electricity to get the fuel for the engine. But... the average vehicle powered by an internal combustion engine, has an alternator which produces electricity when the engine is running, so **there** is a source of electricity to do the electrolysis of the water and produce the gas to run the engine.

But the laws of engineering say that you can't get enough electricity from the alternator to produce enough gas to run the engine. Engineers will point to the work of Faraday who examined the process of electrolysis in great detail and produced the "laws" of electrolysis. These laws show that you can't get enough electrical power from an engine to make enough gas to run the engine.

Unfortunately, there have been several people who have done just that, so we have reached the point in time when these "laws" need to be extended to cover cases not covered by the work of Faraday. People have got from 300% to 1,000% of the gas output which Faraday considered to be the maximum possible.

Several people have run vehicles on hydroxy gas produced by electrolysis of water using electricity generated by the vehicle's alternator. This shows clearly that it can be done, and as a consequence, the "laws" need to be extended to include the newer techniques.

Leaving that aside for the moment, there have been at least two people who have managed to power an engine with water as the only fuel, and without using electrolysis. In this instance, a fine spray of water droplets inside the cylinder is acted on by the spark, and a secondary electrical supply from an inverter boosts the spark, forming a plasma discharge. The result is a power stroke nearly as powerful as using a fossil fuel. For the moment, let us also ignore that style of operation.

This document describes another system which uses water and air as the primary fuels, but again, does not use electrolysis to generate hydroxy gas for use in the engine. Instead, the objective is to create a continuous supply of Nitrogen Hydroxide (NHO_2) for use as the fuel. This system has worked well for a number of people but there has been considerable intimidation and most of these people are very reluctant to pass the information on. This document is an attempt to present those details clearly enough to allow the system to be replicated by anyone who wishes to do so.

So, how exactly is this fuel generated? The production method is described as the fuel gas being synthesised by a mixture of stream water and rock salt (the mineral "halite") in the presence of air, being acted on by engine "vacuum", electrolysis and a strong magnetic field. This fuel is said to be more powerful than hydrogen and is a much more viable fuel source as less of it is needed to run an internal combustion engine.

This system may be used with any internal combustion engine, whether used in a vehicle or stationary when powering an electrical generator or other equipment. The additional equipment consists of one, or more, horizontal cylinders mounted near the engine. A single, horizontally mounted, cylinder can generate sufficient gas to power an internal combustion engine up to two litres in capacity. Larger engines will need two cylinders to generate enough gas for them to operate.

It must be stressed that this is **not** a hydroxy gas electrolysis cell. One test vehicle has been run on this system for a distance of 3,000 miles (4,800 kilometers) and the liquid fuel used was only 2 litres of water and 2 gallons of petrol. Two litres of water converted to hydroxy gas will definitely not power a vehicle engine for anything like 3,000 miles, so let me stress again that the fuel being generated in this cell is Nitrogen Hydroxide (NHO_2). It should be noted that if the cell described here is used as a booster for the original fossil fuel, then it will not be necessary to upgrade the engine by fitting stainless steel valves, piston rings, exhaust system, etc.

The person using this system which is shown in the following photograph, has opted for an exceptionally long generation tube attached to his stationary generator:

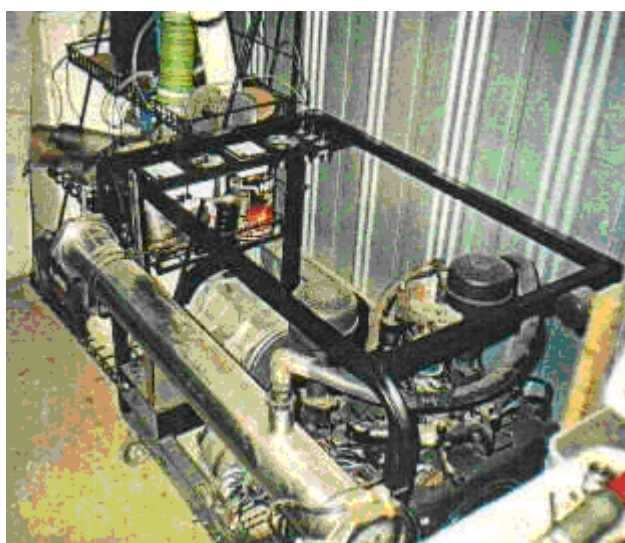

The versions of this cell design shown in the previous photograph and the following photograph, are early models which were in use before it was discovered that there was a considerable enhancement in gas production if a coil is wrapped around the cylinder.

For vehicle operation, it is more normal to have a shorter cylinder, (or pair of cylinders if the engine capacity is large) as can be seen in the following photograph of a 4-litre, 8-cylinder vehicle engine which uses this system. Engines of up to 2 litre capacity can be powered by a single horizontal cell, while two cells are used for larger engines.

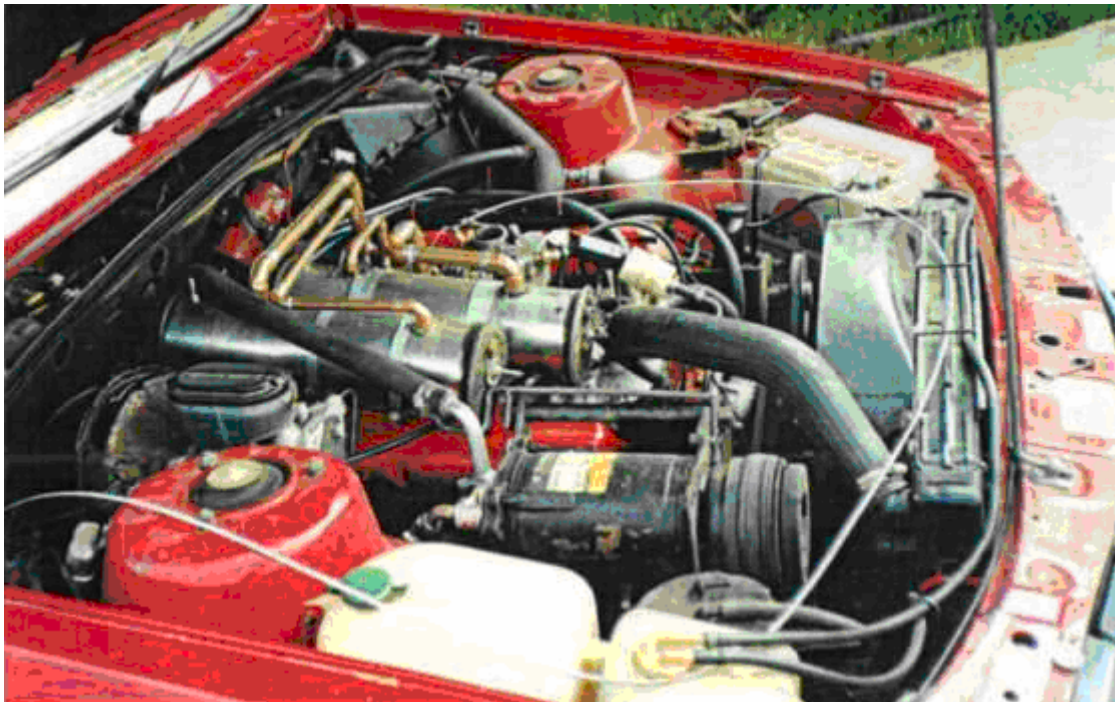

The construction details are not difficult to follow and the materials needed are not particularly difficult to find nor expensive to buy. The main body of the device is constructed as shown in the following diagram. A chamber is constructed from a piece of 316L Grade (food quality) stainless steel pipe, 300 mm (12 inches) long and 100 mm (4 inches) in diameter. The length of 300 mm is chosen for convenience of fitting in the engine compartment of a vehicle. If there is plenty of room there, the length can be extended for better gas performance and water capacity. If that is done, keep the 100 mm cylinder diameter and all of the clearance dimensions mentioned below.

The chamber is sealed at each end with 12 mm (half inch) thick discs made from “Lexan” (a very strong polycarbonate resin thermoplastic). These discs have a 3 mm (1/8”) deep groove cut into their inner faces. The groove is there for the cylinder to fit into when the discs are clamped in place and held by stainless steel nuts tightened on a 10 mm (3/8”) stainless steel threaded rod. To combat engine vibration, a lock nut is used to clamp the retaining nuts in place. The threaded rod also provides the contact point for the negative

side of the electrical supply and a stainless steel bolt is TIG welded to the outside of the cylinder to form the connection point for the positive side of the electrical supply.

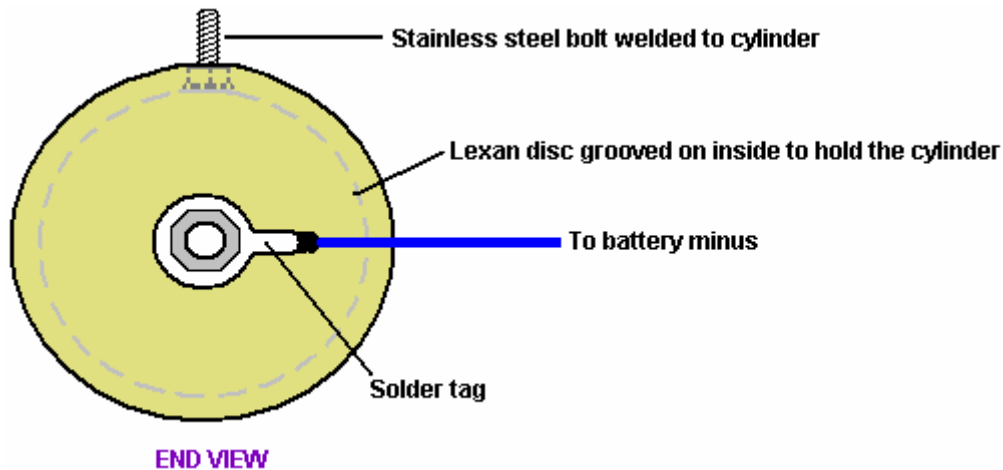
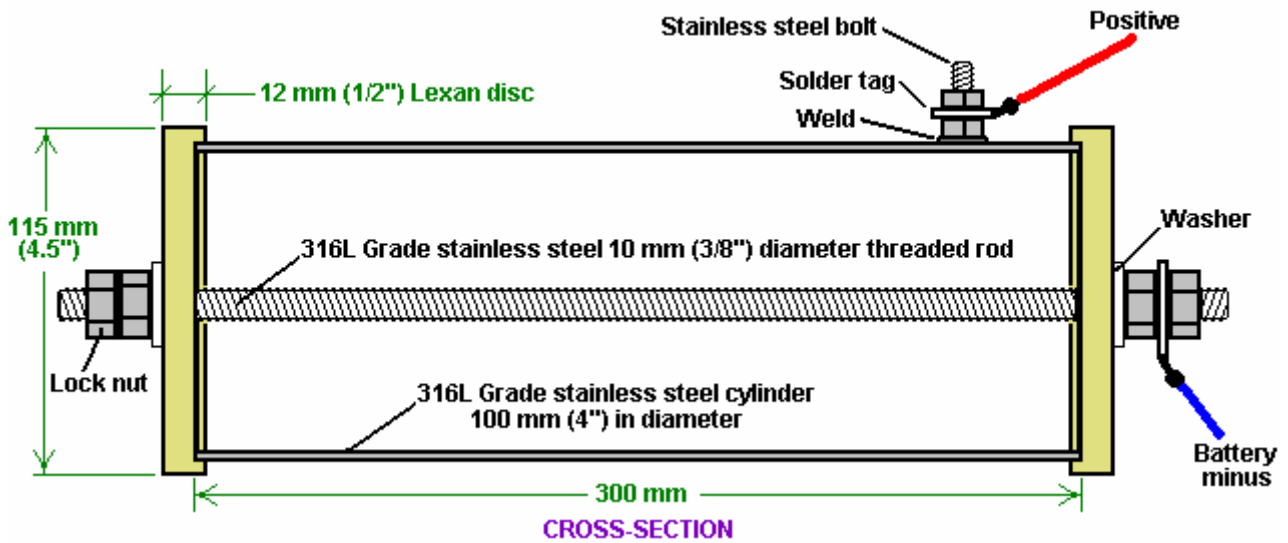

This basic container is modified in a number of ways. Firstly, a small 3 mm (1/8 inch) diameter air intake pipe is provided in one of the Lexan discs. This intake is covered with an anti-slosh material which allows air flow but blocks any liquid from splashing out. This air intake is provided with a needle-valve which is screwed tightly shut for the early stages of testing and only eased slightly open when the engine is actually running.

Also fitted is an 18 mm (3/4") stainless steel pipe, attached to the stainless steel cylinder to form a gas supply feed to the engine. A one-way valve is placed in this pipe as the design calls for the cylinder to be maintained at a pressure which is less than the outside atmosphere. The lower the pressure inside the cell, the greater the rate of gas production. The one-way valve allows flow into the engine but blocks any flow from the engine into the cylinder. This valve is the same type as is used in the vehicle's vacuum brake booster system.

The gas outlet pipe is continued from the one-way valve using plastic tubing for a few inches. This is to prevent an electrical connection between the stainless steel cylinder which is connected to the positive side of the electrical supply, and the engine manifold which is connected to the negative side of the electrical supply. If this pipe were metal all the way, then that would create a direct electrical short-circuit. The pipe running to the engine intake manifold needs to be made of metal in the area near the engine, due to the high engine temperature, so stainless steel pipe should be used for the last part of the gas supply pipe running to the engine. The gas supply pipe fitting is made to the most central of the bungs fitted to the manifold.

For the initial testing period, a filling port with a screw cap is mounted on the top of the cylinder, in order to allow the water inside to be topped up as necessary. Later on, if long journeys are made on a regular basis,

then it is worth fitting a separate water tank, water-level sensor and water injection system using a standard vehicle windscreen washer water pump. The topping up is done with water alone as the rock salt additive does not get used in the process and so does not need to be replaced. With these additional features, the gas generation cell looks like this:

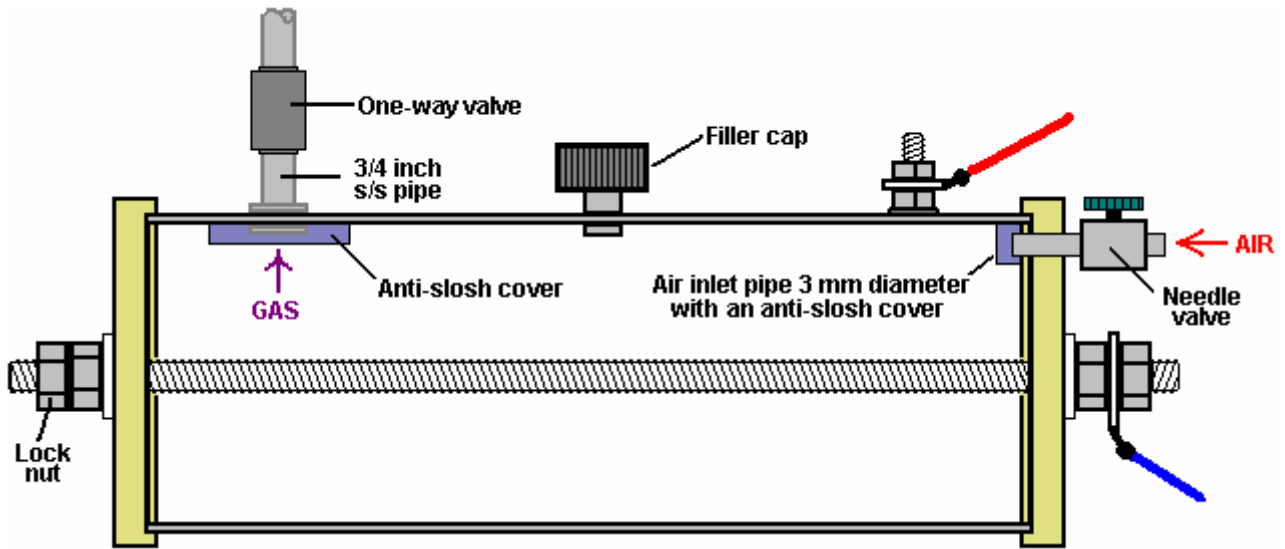

There is one further step, and that is to add an inner cylinder of 316L grade stainless steel. This cylinder is 274 mm (10.75 inches) long and 80 mm (3.15") in diameter. Both cylinders have a wall thickness of 1 mm. The inner cylinder is supported on the central threaded bar and it is clamped in place with retaining nuts. A supporting lug is created by making two cuts at each end of the cylinder, drilling a hole and then bending the lug up inside the cylinder at right angles to its axis. This needs to be done accurately, otherwise the inner cylinder will not lie parallel to the threaded rod, or alternatively, not be centred on the threaded rod. The centre of the 10 mm (3/8") hole is positioned 8 mm (5/16") in from the end of the cylinder. Two 48 mm (1.9") long cuts are made each side of the hole, positioned to be about 5 mm (3/16") clear of the hole - this measurement is not critical. This is done at each end of the cylinder and the holes are positioned exactly opposite one another, along the axis of the cylinder, as shown here:

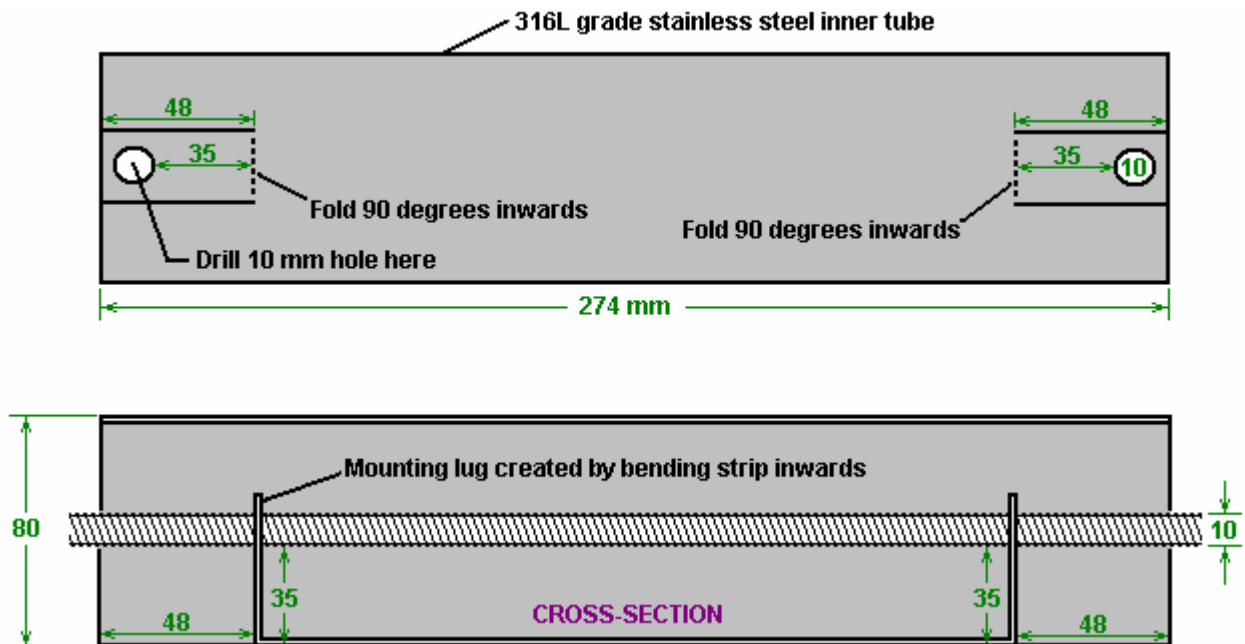

The inner cylinder is secured in position by two bolts as shown here:

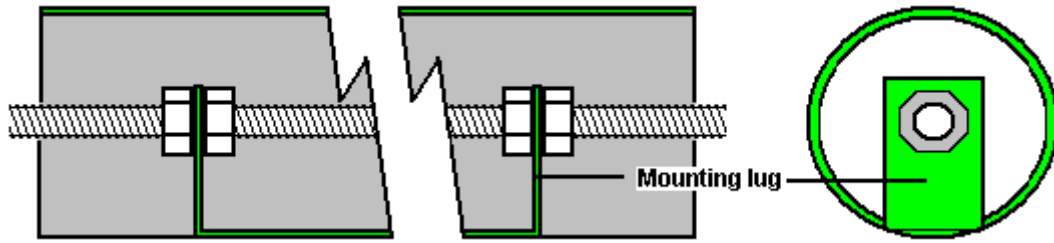

The inner nuts are manoeuvred on inside on of the lugs by hand and then the threaded rod is rotated to move one nut to the inside of the other lug, while the nearer nut is held to prevent it rotating. When the rod is positioned correctly and the inner nuts are pressed up hard against the lugs, then a box spanner is used to lock the outer nuts tightly against the lugs, forming a strong mounting lock.

The inner cylinder is inserted inside the outer cylinder, the Lexan end discs are then added and the outer lock nuts added to produce this arrangement:

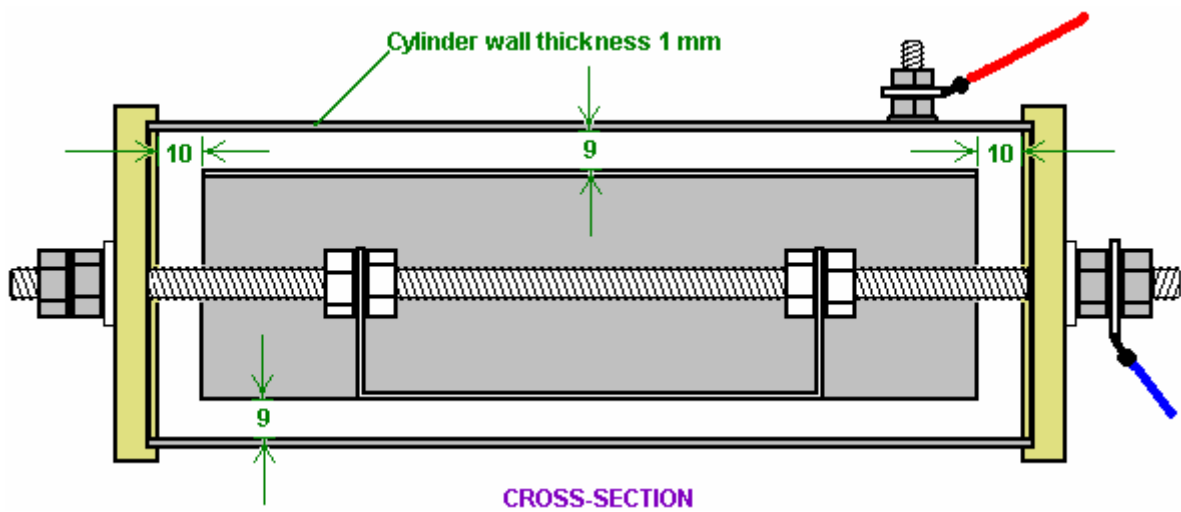

This gives a 9 mm clearance between the two cylinders and this gap stretches 360 degrees around the cylinders. The inner cylinder is located 10 mm clear of the Lexan end discs.

The units is completed by winding a coil of 2 mm diameter insulated copper wire tightly around the full length of the outer cylinder and filling the unit with electrolyte to a level of 3 mm (1/8 inch) above the top of the inner cylinder as shown here:

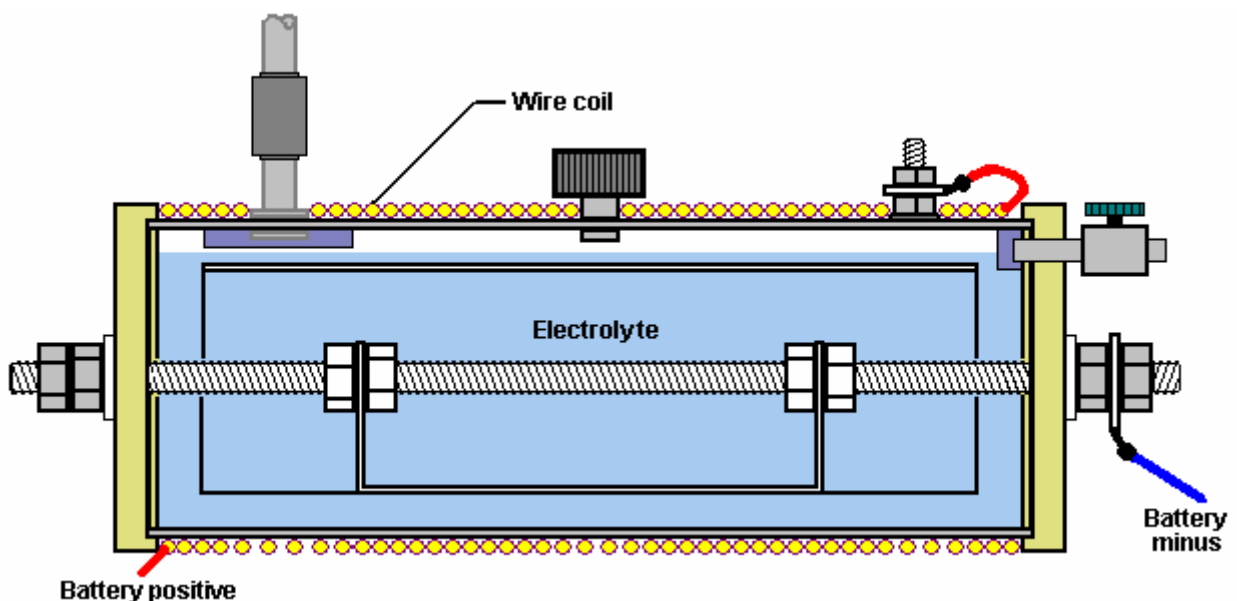

The wire used for the coil is heavy duty copper wire with an inner diameter of 2 mm, i.e. British 14 SWG wire or American 12 AWG wire. The coil is held in position at the ends of the cylinder, with plastic cable ties, as these are non-magnetic. This coil is of major importance in this design as the strong magnetic field produced by it has a very marked effect on the performance of the cell. The magnetic field produced by this coil, increases the gas production by anything from 30% to 50% and increases the production of Nitrogen Hydroxide by a factor of ten times. The electrical connection of the coil is in series with the cell, so the battery positive is not taken directly to the bolt welded to the outer cylinder, but instead it passes through the coil winding before being connected to the outer cylinder.

Installation and Use

The gas outlet pipe is connected directly to a vacuum port directly below the carburettor on the manifold of the engine. This connection is important as the cell relies on the "vacuum" (actually reduced air pressure) produced by the engine intake stroke, as part of it's gas-forming process.

The exact method of mounting the cell in a vehicle depends on the vehicle, so this is something which you will need to think out for yourself. Be sure that you insulate the cell from the metal bodywork of the vehicle and I would suggest that you keep it away from the high-voltage electrical wiring (coil, distributor, spark plug leads, etc.).

The electrical connection arrangement is as shown here:

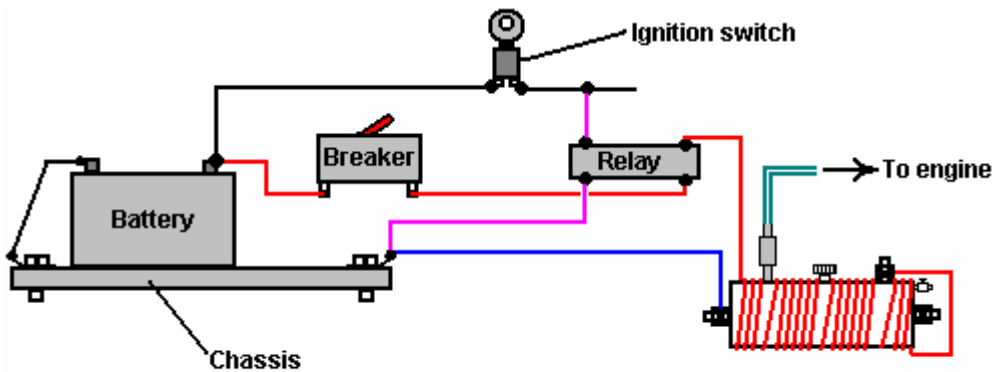

SINGLE - CYLINDER ARRANGEMENT

Or for larger engines:

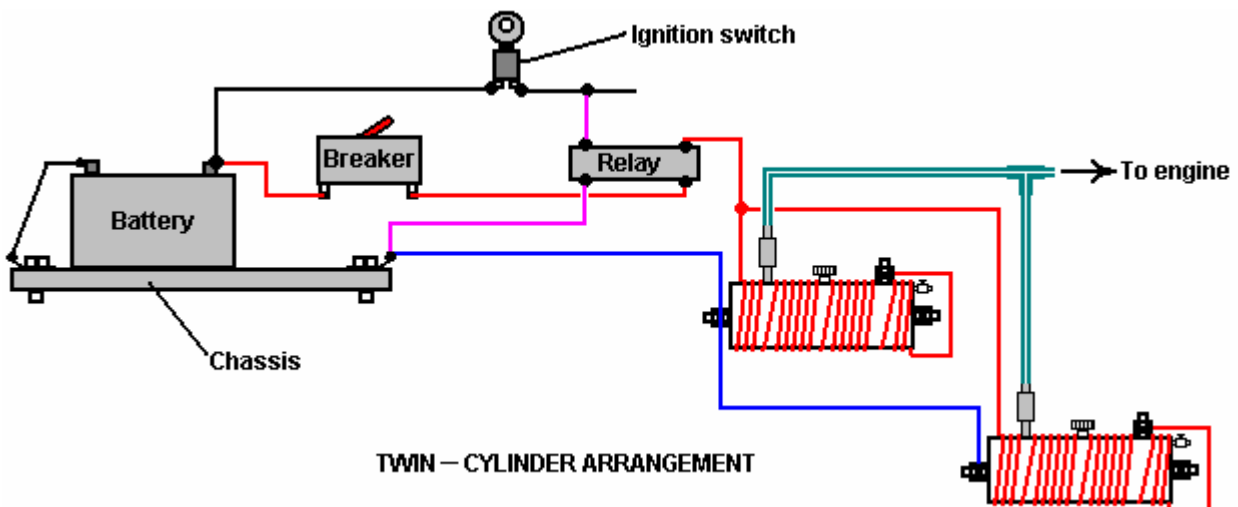

TWIN - CYLINDER ARRANGEMENT

The method of electrical connection is important. It is vital that the electrical supply is disconnected when the engine is not running. For that reason, the power to the cell(s) is taken via the vehicle's ignition switch.

In order not to load that switch unduly, a standard automotive relay is used to carry the main current, leaving just the relay current to be handled by the ignition switch. Also, a 30 amp circuit-breaker or fuse is placed in the circuit, immediately after the battery connection. In the unlikely event of some physical problem with the cell occurring, this device will disconnect the power instantly and avoid any possibility of a short-circuit causing a fire, or of excess gas being produced when it is not needed

The water to be used in this cell needs to be selected carefully. Tap water is not acceptable as it will be contaminated with several additives - fluorine, chlorine, etc. put in it when going through the purification process of the supply company and many other chemicals picked up along the way. It is considered very important that the water be taken from a stream, preferably from where it rises, as that is the point of greatest purity. May I also suggest that the water be transported in either glass containers or stainless steel containers as these help to maintain the purity. Avoid plastic containers, because while these appear to be completely inert, they frequently are most definitely not and chemicals from their manufacture can, and do, enter any liquid contained in them.

The cell is filled to a depth of 3 mm (1/8 inch) above the top of the inner cylinder and then (on the first occasion only) one or two grains of rock salt are added to the cell. This addition needs to be minimal as it controls the current draw from the electrical system and the strength of the magnetic field created by that current. After using the cell for at least a week, if the gas rate is not adequate, then add one more grain of rock salt.

Getting the cell attuned to the vehicle is likely to take at least a week of use. The cell is put in place and the vehicle run using its normal fuel. The needle valve on the cell's air intake is kept completely closed during this period. The inventor opted to continue running his engine on very small amounts of petrol plus this new gas fuel - the result being 3,000 miles covered on just two gallons of petrol. If you consider this as still being a petrol powered vehicle, then getting 1,500 mpg is quite an achievement - I certainly would settle for that.

When the cell is first connected, you will notice that the engine ticks over faster and tends to rev more than it did before. It will take several days for the system to settle down. Part of this is believed to be the effect of the new magnetic coil in the engine compartment. It may be that the metal parts of the vehicle have to take up a magnetic alignment which matches the magnetic field produced by the cell. Whether that is so or not, it will take a few days before the system settles down into its final state.

It should be realised that if the vehicle has a fuel-control computer with an oxygen sensor mounted in the exhaust stream, then the oxygen sensor signal will need to be adjusted. The D17.pdf document of this series, shows in detail how to do this, should it be necessary. If the vehicle has a carburettor, then there is an advantage in fitting a one inch bore carburettor of the type found on lawnmowers, as this promotes lower pressure inside the manifold and promotes good cell operation as the lower the pressure (or the greater the "vacuum"), the higher becomes the rate of gas production.

Practical Details

The original end pieces were cut and grooved using a lathe. Most people do not own or have access to a lathe so an alternative method of cutting the discs needs to be used. The essential part of this operation is to cut an accurate groove to take the 100 mm stainless steel outer cylinder. The groove needs to be cut accurately as it needs to form an airtight seal on the end of the cylinder. Consequently, the end of the cylinder and the bottom of the groove, both need to be straight and true if they are to mate securely.

An alternative method is to use an adjustable hole-cutter drill attachment. If this is used with a drill press or a vertical stand adaptor for an electric hand drill, then if care is taken, an accurate groove of the correct dimensions can be cut. As an extra precaution, a thin layer of marine grade white "SikaFlex 291" bedding compound can be used in the bottom of the groove. Two things here. Firstly, only use the genuine Sikaflex 291 compound even though it is far more expensive than other products which claim to be equivalents - they aren't, so pay for the genuine product. Secondly, we do not want the slightest trace of the Sikaflex contacting the electrolyte if we can avoid it, so be very sparing in the amount put into the groove, no matter what you paid for it. Make sure that the bedding compound is placed only in the very bottom of the groove and not on the sides. When the cylinder is forced into the groove, a very small amount of the compound will be driven into any gap between the cylinder and the sides of the groove.

What is needed is a result which looks like this:

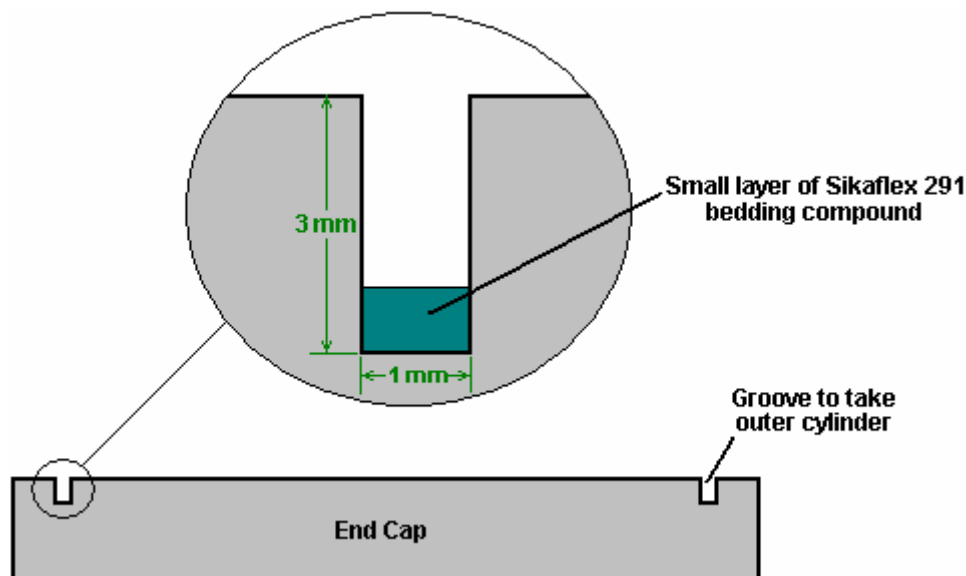

The tool used for cutting the groove, might be one something like this adjustable unit made by Clarke. In the UK, this is supplied by Machine Mart and there will almost certainly be an equivalent item in other countries:

Clarke[™]

CHT518 Hole Cutter Set

Clarke's adjustable hole-cutter is suitable for drilling a wide range of materials including plasterboard, wood & processed timber sheeting, acrylics and plastics. It provides a neat and effective way of cutting various diameters of aperture in walls, ceilings, doors, partitions etc. for the purpose of installing light fittings, ventilation, plumbing etc.

- Cuts holes from 38 to 180mm diameter
- Cuts material up to 30mm thick
- Includes 2 TCT blades for wood, acrylic and plastic
- Includes 2 HSS blades for plasterboard
- Incorporates perspex cowl for collecting waste material - especially useful for ceiling work
- Suitable for use with any conventional power drill



- Supplied as a kit, with 5 pilot drills, in a tough blow moulded carry case

The other important part of this joint is the end of the outer cylinder. It is recommended that the cylinder be cut by hand with a hacksaw to avoid generating excessive heat which can affect the structure of the metal. To get the end exactly square, use a piece of printer paper. This has straight edges and square corners, so wrap it flat around the cylinder and manoeuvre it into place so that the overlapping edges match exactly on both sides. If the paper is flat and tight against the cylinder and the edges match exactly, then the edge of the paper will be an exact true and square line around the cylinder. Mark along the edge of the paper with a felt pen and then use that line as a guide to a perfectly square cut. To avoid excessive heat, do not use any power tool like an angle grinder on the cylinder. Just clean the edges of the cut gently with a hand file.

In the diagrams shown earlier, the gas pipe, water filler cap and the battery positive connection bolt have all been shown on the top of the cylinder. This is only to show them clearly, and there is no need to have them positioned like that. You will notice that they all get in the way of the wire coil, which is not an advantage.

It is necessary for the gas pipe to be positioned at the top as that gives the best clearance above the water surface. The clearance is not great, being a maximum of just 6 mm (1/4 inch). Also, to avoid water being splashed into the pipe, it is necessary to attach a piece of "anti-slosh" material over the pipe opening. This can be the type of matting used in aquariums as it allows the passage of gas but blocks liquids. Some people like to use plastic scourer material here. Whatever material is chosen, it needs to be inert and not react with the salt solution in any way, block any splashes of liquid and let gas flow freely through it. An alternative is to construct baffles to protect the outlet, but that is a more difficult method to construct.

The water filler cap which was shown on top of the cylinder, would be better positioned on one of the end caps as that would keep it out of the way of the coil of wire:

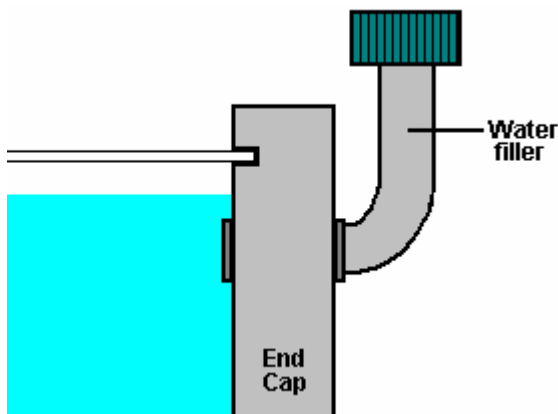

This arrangement has the advantage that it does not require a filler hole to be drilled through the steel cylinder.

It is necessary for the electrical connection to be welded to the cylinder, but it is not necessary to have a head on the bolt as that just gets in the way of the electrical coil. The best strategy is to use a longer bolt of small diameter, remove the head and weld the shaft in place with spot welds which will not get in the way of the coil, as shown below. Spot welds are very quick to make, but even they generate a good deal of heat in the pipe. Some people prefer to silver-solder the bolt shaft to the cylinder as the heating is less.

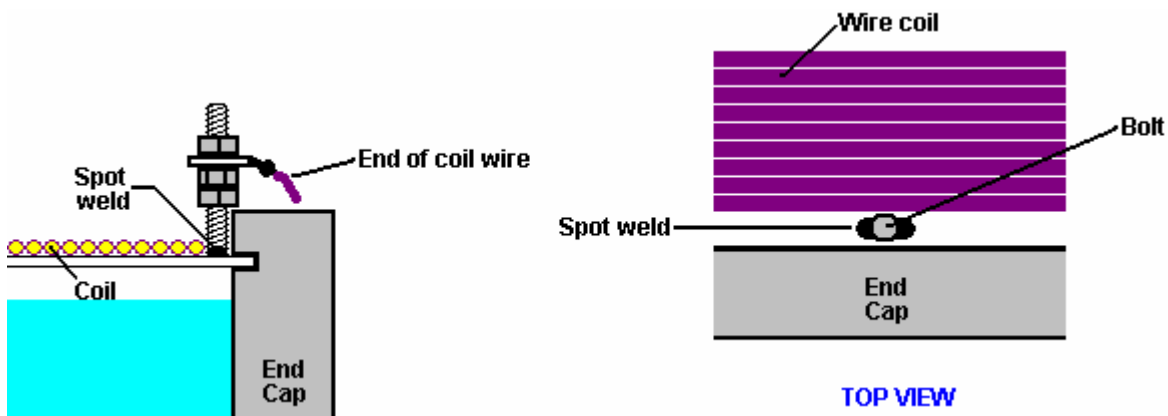

The bolt is kept just clear of the end cap to avoid fouling it when it is clamped on to the cylinder. A lock nut is used to keep the solder tag assembly clear of the outer edge of the end cap. This allows the wire coil to be wound right up to the bolt. It does not matter which end of the coil is connected to the outer cylinder, but common sense suggests that the end nearest the bolt is connected to the bolt. It is, however, important that once connected, the electrical connections to the coil are maintained ever afterwards, to ensure that the magnetic field stays in the same direction. Remember that the surrounding metal parts of the vehicle will take up a magnetic orientation matching that of the coil's magnetic field, so you do not want to keep changing the direction of the coil's magnetic field.

When welding the bolt to the outer cylinder, be sure you use stainless steel wire. The joint needs to be made with a MIG or TIG welder. If you don't have one and can't hire one, then your local metal fabrication shop will make the spot welds for you in less than a minute and probably not charge you for doing them.

The grade of stainless steel in the cylinders is important. Grade 316L is nearly non-magnetic, so if you hold the cylinder with its sides vertical and place a magnet against the cylinder, the magnet should fall off under its own weight. Try this test no matter what grade the stainless steel is supposed to be, as some steels are not labelled correctly. There is a good chance that you will be able to find suitable tubing at your local scrapyards, but be careful on sizing. The 9 mm gap between the outer 100 mm diameter cylinder and the inner cylinder's 80 mm diameter, is very important indeed. This gap needs to be 9 mm (11/32 inch) so if really necessary to vary the diameters slightly up or down, be sure to pick material which gives the correct gap between the cylinders. Seamless piping is usually preferred to pipes which have seams as the seam welding tends to generate a magnetic effect in the steel. However, if a seamed pipe passes the magnet test with the magnet falling off it, it is definitely good material for the cell.

If you can get it, a good material for the 18 mm (3/4 inch) pipe running to the carburettor manifold, is aluminium. Please remember that the one-way valve on the cell's output pipe needs to be connected to this pipe with a material which insulates the two metal components. The suggested piping is therefore: the cell output is via a stainless steel pipe connector, connected directly to the one-way valve, which then has a plastic pipe connection to the aluminium tube which runs all the way to the manifold. Please remember to insulate the cell from the vehicle chassis and components to avoid a short-circuit.

An alternative to using the rather expensive "Lexan" for the end caps, is to use "UHMWP" - Ultra-High Molecular Weight Polyethylene which is cheap and easy to obtain as plastic food-chopping boards are usually made from it. The advantage of Lexan is that it is transparent and so the level of the electrolyte can be seen without the need for removing the water filler cap.

It has been suggested that the topping up of water in the cell can be automatic if you wish it to be so. For this, a water-level sensor circuit is used to drive a standard windscreen washer water pump when the level of the electrolyte falls below the design level. The sensor itself, can be a bolt running through one of the end caps as shown here:

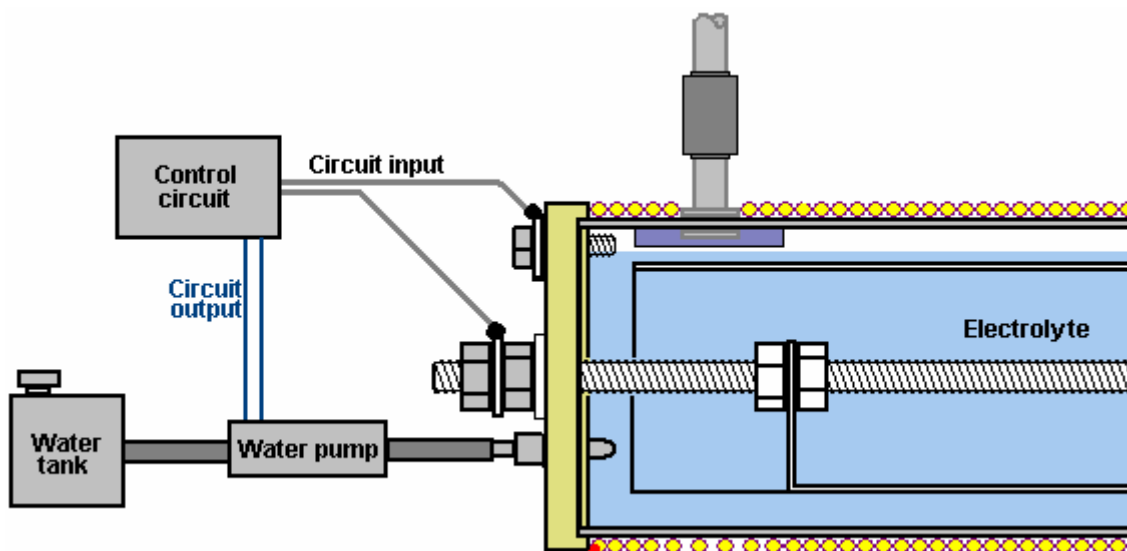

When the electrolyte level drops below the upper bolt, the circuit contact to the control circuit is broken and the circuit responds by powering up the water pump, which injects a little water to bring the electrolyte level back up to where it should be. When the vehicle is moving, the surface of the electrolyte will not be steady as shown in the diagram, so the control circuit needs to have an averaging section which prevents the water pump being switched on until the circuit input has been missing for several seconds.

Circuitry suitable for this is shown in the electronics tutorial at www.web-space.tv/free-energy (needs the browser's Refresh button to get past a German-language advertisement page to reach the site) and there is no reason why you should not design and build your own circuit for this.

In the initial stages of testing and installation, when adding rock salt, be very sparing indeed. Add just one grain at a time because the salt ions are very effective in carrying current through the electrolyte solution.

Also, if too much is added, it is difficult to reduce the concentration as more water needs to be added, which involves draining off some of the water already in the cell. It is much easier to take your time and add very, very little salt. Give the salt grain plenty of time to dissolve and spread out throughout the electrolyte before checking the cell performance again.

Let me remind you that during the initial cell testing, the air intake needle valve is closed completely and it is not eased open until the engine is running satisfactorily. In the engine acclimatisation period, the engine should be run on it's normal fuel and the cell just used as a booster. Remember that it will take at least a week for the vehicle to settle down to it's new method of operation. There is no particular hurry, so take your time and don't rush things.

If the vehicle is fitted with computer control of the fuel supply, it may be necessary to apply some control to the unit by adjusting the signal coming from the oxygen sensor placed in the vehicle's exhaust system. The information on how to do this is shown in considerable detail in the companion document "D17.pdf" which can be downloaded free from www.web-space.tv/free-energy (needs the browser's Refresh button to get past a German-language advertisement page to reach the site).

Some questions have been asked about this cell:

1. Does petrol have to be used or can the engine be run on the cell alone?

Answer: No, you can eventually eliminate petrol altogether but the engine runs so cleanly that old carbon deposits around the piston rings and elsewhere will get cleaned away and the components may rust. These parts can eventually be replaced with stainless steel versions or instead of that, it is probably possible to avoid replacements by the use of the oil additive called "Vacclaisocryptene QX and Molybdenum Disulfide" - see <http://www.clickspokane.com/vacclaisocryptene/> for details. This additive reduces wear to such a degree that engine life may be doubled, no matter what fuel is being used.

2. Why is the unit 300 mm long?

Answer: Just for convenience in fitting it into the engine compartment. It can easily be longer if space allows it. The longer the unit, the greater the gas production and that is why two 300 mm cells are needed for engines over 2 litres in capacity.

3. Does the cell body need to be made from seamless pipe?

Answer: Seamless 316L-grade stainless steel is preferred.

4. How do you determine the amount of rock salt to add to the water in the cell?

Answer: The amount varies with the type and size of engine being dealt with. You want the minimum current through the coil so start with one grain and increase it only very gradually with tiny amounts. If the cell is being mounted in the engine compartment of a vehicle, then the make, model and size of the vehicle will affect the amount due to the magnetic effect of metal components near the cell.

5. Does it matter which end of the coil is attached to the outer cylinder?

Answer: No, it can be either end.