

THE No.1 MAGAZINE FOR ELECTRONICS TECHNOLOGY & COMPUTER PROJECTS

EVERYDAY

Vol.32 No.2

PRACTICAL

ELECTRONICS

CAN \$6.99/US \$4.95

TESLA TRANSFORMER

Creates sizzling
DIY lightning

BRAINIBOT

PC based
robotic buggy

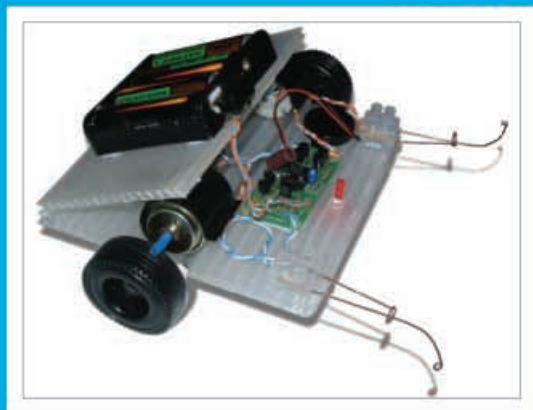

WIND TUNNEL

Investigate
the effects
of airflow

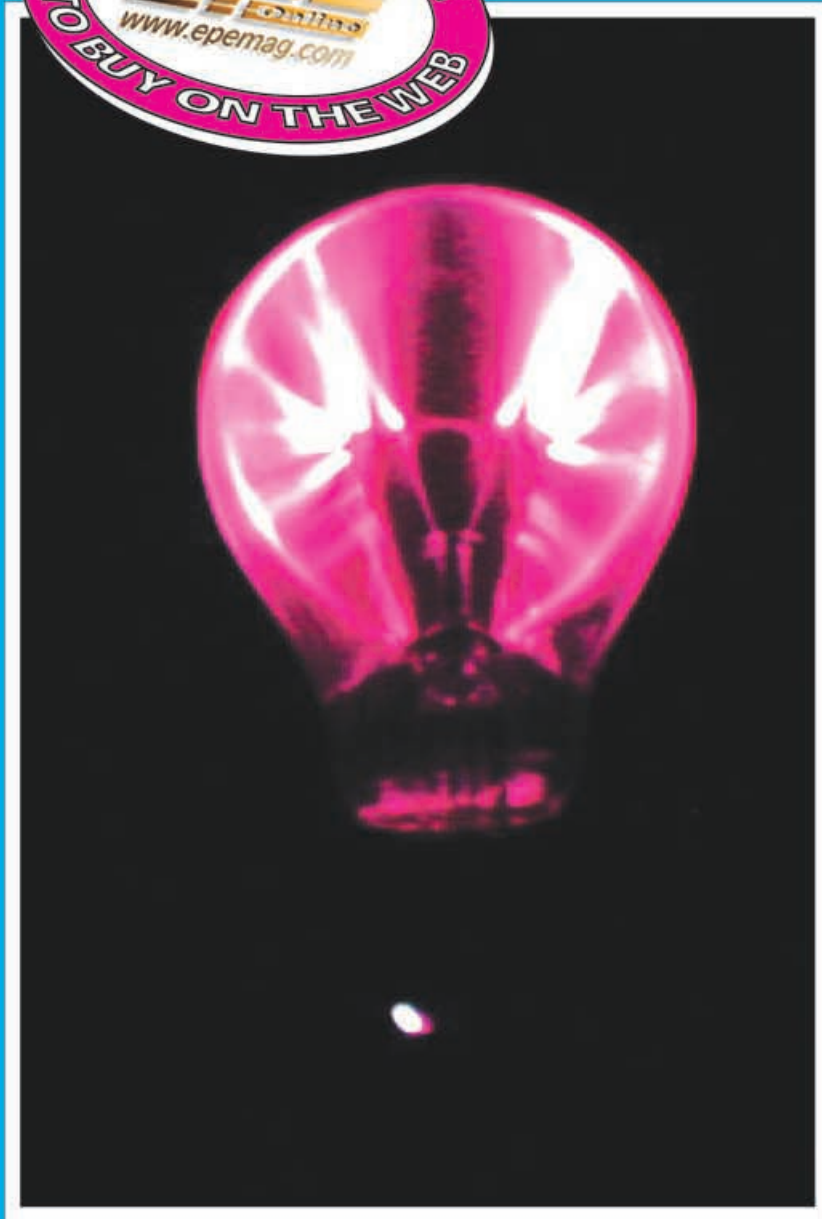

■■■■ NEW SERIES

**BACK TO BASICS - Introduction
plus two projects**



<http://www.epemag.wimborne.co.uk>

Copyright © 2003, Wimborne Publishing Ltd
(408 Wimborne Road East, Ferndown, Dorset, BH22 9ND, UK)

and TechBites Interactive Inc.,
(PO Box 857, Madison, Alabama 35758, USA)

All rights reserved.

WARNING!

The materials and works contained within *EPE Online* — which are made available by Wimborne Publishing Ltd and Maxfield & Montrose Interactive Inc — are copyrighted. You are permitted to make a backup copy of the downloaded file and one (1) hard copy of such materials and works for your personal use. International copyright laws, however, prohibit any further copying or reproduction of such materials and works, or any republication of any kind.

Maxfield & Montrose Interactive Inc and Wimborne Publishing Ltd have used their best efforts in preparing these materials and works. However, Maxfield & Montrose Interactive Inc and Wimborne Publishing Ltd make no warranties of any kind, expressed or implied, with regard to the documentation or data contained herein, and specifically disclaim, without limitation, any implied warranties of merchantability and fitness for a particular purpose.

Because of possible variances in the quality and condition of materials and workmanship used by readers, *EPE Online*, its publishers and agents disclaim any responsibility for the safe and proper functioning of reader-constructed projects based on or from information published in these materials and works. In no event shall Maxfield & Montrose Interactive Inc or Wimborne Publishing Ltd be responsible or liable for any loss of profit or any other commercial damages, including but not limited to special, incidental, consequential, or any other damages in connection with or arising out of furnishing, performance, or use of these materials and works.

ISSN 0262 3617

PROJECTS ... THEORY ... NEWS ...
COMMENTS ... POPULAR FEATURES ...

VOL. 32. No. 2 FEBRUARY 2003

Cover illustration by Raymond Haigh

EVERYDAY PRACTICAL ELECTRONICS

INCORPORATING ELECTRONICS TODAY INTERNATIONAL

www.epemag.wimborne.co.uk

EPE Online: www.epemag.com

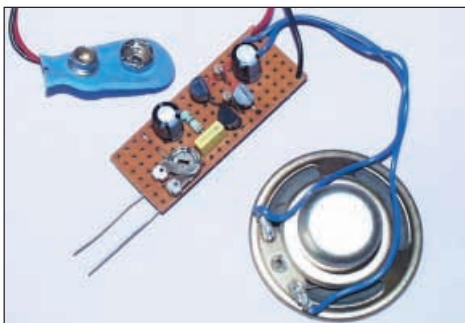
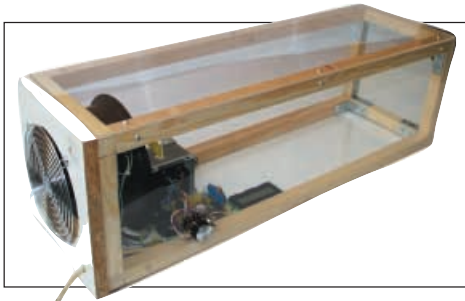
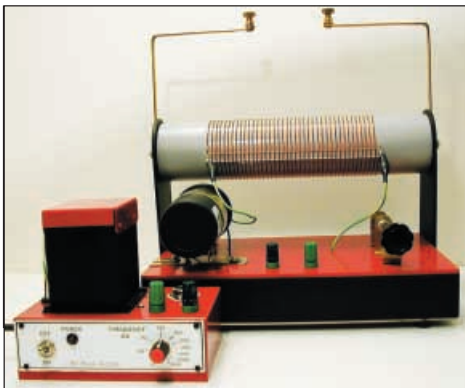
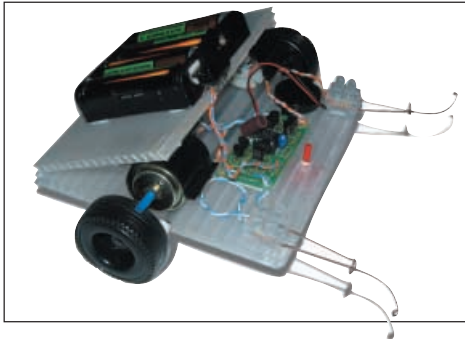

© Wimborne Publishing Ltd 2003. Copyright in all drawings, photographs and articles published in **EVERYDAY PRACTICAL ELECTRONICS** is fully protected, and reproduction or imitations in whole or in part are expressly forbidden.

Projects and Circuits

- BRAINIBOT BUGGY** by Mark Stuart and Peter Balch 92
A low-cost, easy-build buggy that has a mind of its own!
- WIND TUNNEL** by John Becker 105
Scientifically investigate Nature's second essential element
- INGENUITY UNLIMITED** hosted by Alan Winstanley 114
Single-Cylinder Ignition; Reaction Timer
- BACK TO BASICS – Part 1. Hearing Aid, Audio Power Amplifier** 130
by Bart Trepak. Illustrating how transistors can create useful designs
- TESLA HIGH VOLTAGE TRANSFORMER** by Raymond Haigh 143
Spectacularly create your own sizzling DIY lightning!

Series and Features

- NEW TECHNOLOGY UPDATE** by Ian Poole 98
Carbon nano-tubes are likely to have a serious impact on semiconductor technology
- CIRCUIT SURGERY** by Alan Winstanley and Ian Bell 102
More on MOSFETs; Switching Speed of A.C. Motors
- IN THE BAG** by Terry de Vaux-Balbirnie 117
Have you ever wondered how your car airbags work?
- NET WORK – THE INTERNET PAGE** surfed by Alan Winstanley 122
The Last Keyword in Sales; Favourite Sites
- TECHNO TALK** by Andy Emmerson 136
Hotspots to the Rescue
- INTERFACE** by Robert Penfold 138
Direct control of PC serial lines using MSCOMM

Regulars and Services

- EDITORIAL** 91
- NEWS** – Barry Fox highlights technology's leading edge 99
Plus everyday news from the world of electronics
- BACK ISSUES** Did you miss these? Many now on CD-ROM! 123
- READOUT** John Becker addresses general points arising 126
- SHOPTALK** with David Barrington 129
The *essential* guide to component buying for *EPE* projects
- PLEASE TAKE NOTE** PIC Intruder Alarm (Apr '02); PIC-pocket Battleships (Oct '02); BioPIC Heartbeat Monitor (May '02) 129
- CD-ROMS FOR ELECTRONICS** 140
A wide range of CD-ROMs for hobbyists, students and engineers
- DIRECT BOOK SERVICE** 152
A wide range of technical books available by mail order, plus more CD-ROMs
- PRINTED CIRCUIT BOARD AND SOFTWARE SERVICE** 155
PCBs for *EPE* projects. Plus *EPE* project software
- ELECTRONICS MANUALS** 156
Essential reference works for hobbyists, students and service engineers
- ADVERTISERS INDEX** 160

Our March 2003 issue will be published on Thursday, 13 February 2003. See page 83 for details

Readers Services • Editorial and Advertisement Departments 91

GIANT 10" 7-SEGMENT DISPLAYS

A bulk purchase enables us to bring to you these GIANT 7-segment digital displays at a now affordable price! The 10" character size gives exceptional readability at long distances and enables a host of applications including, score boards, digital clocks, counters, event timers etc. As the units are a simple electro-mechanical device and operate from 12V DC, simple switching via switches, relays, PIC or PC may be used to control single or multiple digits. Units feature integral 'Zero Power' memory which greatly simplifies design. For an excellent DIY practical article, see the May issue of 'Everyday Practical Electronics' magazine. Ideal School / College construction project. Supplied in good RFE condition, complete with data sheet.



Less than 30% of makers price **Only £29.95 (B) or 4 / £99.00 (D)**
Order RW44 Order PH26

THE AMAZING TELEBOX



TV SOUND & VIDEO TUNER
CABLE COMPATIBLE

Converts your colour monitor into a QUALITY COLOUR TV!!

The TELEBOX is an attractive fully cased mains powered unit, containing all electronics ready to plug into a host of video monitors or AV equipment which are fitted with a composite video or SCART input. The composite video output will also plug directly into most video recorders, allowing reception of TV channels not normally receivable on most television receivers* (TELEBOX MB). Push button controls on the front panel allow reception of 8 fully tuneable 'off air' UHF colour television channels. TELEBOX MB covers virtually all television frequencies VHF and UHF including the HYPERBAND as used by most cable TV operators. Ideal for desktop computer video systems & PIP (picture in picture) setups. For complete compatibility - even for monitors without sound - an integral 4-watt audio amplifier and low level Hi Fi audio output are provided as standard. Brand new - fully guaranteed.

TELEBOX ST for composite video input type monitors £36.95
TELEBOX ST as ST but fitted with integral speaker £39.50
TELEBOX MB Multiband VHF/UHF/Cable/Hyperband tuner £69.95
For overseas PAL versions state 5.5 or 6 mHz sound specification.
*For cable / hyperband signal reception Telebox MB should be connected to a cable type service. Shipping on all Teleboxes, code (B)

NEW State of the art PAL (UK spec) UHF TV tuner module with composite 1V pp video & NICAM hi fi stereo sound outputs. Micro electronics all on one small PCB only 73 x 100 x 52 mm enable full tuning control via a simple 3 wire link to an IBM pc type computer. Supplied complete with simple working program and documentation. Requires +12V & +5V DC to operate. **BRAND NEW - Order as MY00. Only £39.95 code (B)**
See www.distel.co.uk/data_my00.htm for picture + full details

HARD DISK DRIVES 2 1/2" - 14"

2 1/2" TOSHIBA MK1002MAV 1.1Gb laptop (12.5 mm H) **New £59.95**
2 1/2" TOSHIBA MK4313MAT 4.3Gb laptop (8.2 mm H) **New £105.00**
2 1/2" TOSHIBA MK6409MAV 6.1Gb laptop (12.7 mm H) **New £98.00**
2 1/2" TOSHIBA MK1614GAV 18 Gb laptop (12 mm H) **New £149.95**
2 1/2" to 3 1/2" conversion kit for PCs, complete with connectors £15.95
3 1/2" COMPAQ 313706-B2 (IBM) 9 gb ULT/SCSI3 **New £199.00**
3 1/2" FUJII FC-309-26 20mb MFM I/F RFE **£59.95**
3 1/2" CONNER CP3024 20 mb IDE I/F (or equiv.) RFE **£59.95**
3 1/2" CONNER CP3044 40 mb IDE I/F (or equiv.) RFE **£69.00**
3 1/2" QUINTUM 40s Prodriv v 42mb SCSI I/F, New RFE **£49.00**
5 1/4" MINISCRIBE 3425 20mb MFM I/F (or equiv.) RFE **£49.95**
5 1/4" SEAGATE ST-238R 30 mb RLL I/F Refurb **£69.95**
5 1/4" CDC 94205-51 40mb HH MFM I/F RFE tested **£99.00**
5 1/4" HP 97548 850 Mb SCSI RFE tested **£69.95**
5 1/4" HP C3010 2 Gbyte SCSI differential RFE tested **£195.00**
8" NEC D2246 85 Mb SMD interface. **New £99.00**
8" FUJITSU M2322K 160Mb SMD I/F RFE tested **£195.00**
8" FUJITSU M2392K 2 Gb SMD I/F RFE tested **£345.00**
Many other floppy & H drives, IDE, SCSI, ESDI etc from stock, see website for full stock list. Shipping on all drives is code

TEST EQUIPMENT & SPECIAL INTEREST ITEMS

MITSUBISHI FA345SETKL 14" Ind. spec SVGA monitors £245
FARNELL 0-60V DC @ 50 Amps, bench Power Supplies £995
FARNELL AP3080 0-30V DC @ 80 Amps, bench Supply £1850
KINGSHILL CZ403/1 0-50V @ DC 200 Amps - New £3950
1KW to 400 KW - 400 Hz 3 phase power sources - ex stock £POA
IBM 8230 Type 1, Token ring base unit driver £760
Wayne Kerr RA200 Audio frequency response analyser £2500
INFODEC 11, 20 port, RJ45 network patchpanels. #TH93 £49
3COM 16670 12 Port Ethernet hub - RJ45 connectors #LD97 £69
3COM 16671 24 Port Ethernet hub - RJ45 connectors £89
3COM 16700 8 Port Ethernet hub - RJ45 connectors New £39
IBM 53F5051 Token Ring ICS 20 port lobe modules £POA
IBM MAU Token ring distribution panel 8228-23-5050N £45
AIM 501 Low distortion Oscillator 9Hz to 330KHz, IEEE I/O £550
ALLGON 8360.11805-1880 MHz hybrid power combiners £250
Trend DSA 274 Data Analyser with G703(2M) 64 i/o £POA
Marconi 6310 Programmable 2 to 22 GHz sweep generator £4500
Marconi 2022C 10KHz-1GHz RF signal generator £1550
HP1650B Logic Analyser £3750
HP3781A Pattern generator & HP3782A Error Detector £POA
HP6621A Dual Programmable GPIB PSU 0-7 V 160 watts £1800
HP6264 Rack mount variable 0-20V @ 20A metered PSU £475
HP54121A DC to 22 GHz four channel test set £POA
HP8130A opt 020 300 MHz pulse generator, GPIB etc £7900
HP A1, A0 8 ben HPGL high speed drum plotters - from £550
HP DRIFTMASTER 1 8 pen high speed plotter £750
EG+G Brookdale 95035C Precision lock in amp £1800
Keithley 590 CV capacitor / voltage analyser £POA
Racal ICR40 dual 40 channel voice recorder system £3750
Fiskers 45KVA 3 ph On Line UPS - New batteries £4500
Emerson AP130 2.5KVA Industrial spec UPS £1499
Mann Tally MT645 High speed line printer £2200
Intel SBC 486/133SE Multibus 486 system, 8Mb Ram £945

IC's - TRANSISTORS - DIODES

OBSOLETE - SHORT SUPPLY - BULK
10,000,000 items EX STOCK
For MAJOR SAVINGS
CALL or see web site www.distel.co.uk

COMPUTER MONITOR SPECIALS

Legacy products
High spec genuine multisync.
CGA, EGA, VGA, SVGA

Mitsubishi FA345SETKL 14" SVGA Multisync colour monitor with fine 0.28 dot pitch tube and resolution of 1024 x 768. A variety of inputs allows connection to a host of computers including IBM PC's in CGA, EGA, VGA & SVGA modes, BBC, COMMODORE (including Amiga 1200), ARCHIMEDES and APPLE. Many features: Etched faceplate, text switching and LOW RADIATION MPR specification. Fully guaranteed, in EXCELLENT little used condition. Tilt & Swivel Base £4.75

VGA cable for IBM PC included. **Only £129 (E)** Order as CG73

External cables for other types of computers available - CALL

Generic LOW COST SVGA Monitors

We choose the make, which includes Compaq, Mitsubishi, IBM, etc. Supplied ready to run with all cables, Standard RTB 90 day guarantee.

14" £59.00	15" £69.00	17" £79.00
---------------	---------------	---------------

Supplied in good used condition. Shipping code (D)

VIDEO MONITORS

PHILIPS HCS35 (same style as CM8833) attractively styled 14" colour monitor with both RGB and standard composite 15.625 KHz video inputs via SCART socket and separate phono jacks. Integral audio power amp and speaker for all audio visual uses. Will connect direct to Amiga and Atari BBC computers. Ideal for all video monitoring / security applications with direct connection to most colour cameras. High quality with many features such as front concealed flap controls, VCR correction button etc. Good used condition - fully tested - guaranteed
Dimensions: W14" x H12.24" x 15.12" D. **Only £99.00 (E)**

PHILIPS HCS31 Ultra compact 9" colour video monitor with standard composite 15.625 KHz video input via SCART socket. Ideal for all monitoring / security applications. High quality, ex-equipment fully tested & guaranteed (possible minor screen burns). In attractive square black plastic case measuring W10" x H10" x 13.12" D. 240 V AC mains powered. **Only £79.00 (D)**

INDUSTRIAL COMPUTERS

Tiny shoebox sized industrial 40 Mhz 386 PC system measuring only (mm) 266 x X 88 x X 272 d. Ideal for dedicated control applications running DOS, Linux or even Windows! Steel case contains 85 to 265 V AC 50 / 60 Hz 70 Watt PSU, a 3 slot ISA passive backplane and a Rocky 318 (PC104) standard, single board computer with 8 MByte NON VOLATILE solid state 'Disk On Chip' RAMDISK. System comprises: Rocky 318 (PC104) SBC ISA card with 40MHz ALI 386SX CPU, 72 pin SIMM slot with 16 MByte SIMM, AMI BIOS, battery backed up real time clock. 2 x 9 pin D 16550 serial ports. EPP/ECP printer port, mini DIN keyboard connector, floppy port, IDE port for hard drives up to 528 MByte capacity, watchdog timer and PC/104 bus socket. The 8 MByte solid state 'disk on a chip' has its own BIOS, and can be formatted, formatted & booted. Supplied BRAND NEW fully tested and guaranteed. For full data see featured item on website. Order as QG36

100's of applications inc: firewalls, routers, robotics etc. **Only £99.00 (D)**

19" RACK CABINETS

Europe's Largest Stocks of quality rack cabinets, enclosures and accessories. Over 1000 Racks from stock

This month's special
33 / 42 / 47 U - High Quality
All steel Rack Cabinets

Made by Eurocraft Enclosures Ltd to the highest possible spec, rack features all steel construction with removable side, front and back doors. Front and back doors are hinged for easy access and all lockable with five secure 5 lever barrel locks. The front door is constructed of double walled steel with a 'designer style' smoked acrylic front panel to enable status indicators to be seen through the panel, yet remain unobtrusive. Internally the rack features fully slotted reinforced vertical fixing members to take the heaviest of 19" rack equipment. The two movable vertical fixing struts (extras available) are pre punched for standard 'cage nuts'. A mains distribution panel internally mounted to the bottom rear, provides 8 x IEC 3 pin Euro sockets and 1 x 13 amp 3 pin switched utility socket. Overall ventilation is provided by fully louvered back door and double skinned top section with top and side louvers. The top panel may be removed for fitting of integral fans to the sub plate etc. Other features include: fitted castors and floor levelers, prepunched utility panel at lower rear for cable / connector access etc. Supplied in excellent, slightly used condition with keys. Colour Royal blue, some grey available - CALL - Can be supplied in many other configurations.

33U Order as BC44 External dimensions mm=1625h x 635D x 603 W. (64" H x 25" D x 23 3/4" W) Only £245	42U Order as DT20 External dimensions mm=2019h x 635D x 603 W. (79.5" H x 25" D x 23 3/4" W) Only £345	47U Order as RV36 External dimensions mm=2019h x 635D x 603 W. (88" H x 25" D x 23 3/4" W) Only £410
---	---	---

Call for shipping quotation

COLOUR CCD CAMERAS

Undoubtedly a miracle of modern technology & our special buying power! A quality product featuring a fully cased COLOUR CCD camera at a give away price! Unit features full auto light sensing for use in low light & high light applications.
A 10 mm fixed focus wide angle lens - gives excellent focus and resolution from close up to long range. The composite video output will connect to any composite monitor or TV (via SCART socket) and most video recorders. Unit runs from 12V DC so ideal for security & portable applications where mains power not available. Overall dimensions 66 mm wide x 117 deep x 43 high. Supplied BRAND NEW & fully guaranteed with user data, 100's of applications including Security, Home Video, Web TV, Web Cams etc, etc.

Order as LK33 **ONLY £79.00 or 2 for £149.00 (B)**

SOFTWARE SPECIALS

NT4 WorkStation, complete with service pack 3 and licence - OEM packaged. **ONLY £89.00 (B)**
ENCARTA 95 - CDROM. Not the latest - but at this price! £7.95
DOS 5.0 on 3 1/2" disks with concise books & V.90 basic £14.95
Windows for Workgroups 3.11+ Dos 6.22 on 3.5" disks £55.00
Windows 95 CDROM Only - No Licence - £19.95

Wordperfect 6 for DOS supplied on 3 1/2" disks with manual £24.95

SOLID STATE LASERS

Visible red, 670nm laser diode assembly. Unit runs from 5 V DC at approx 50 mA. Originally made for continuous use in industrial barcode scanners, the laser is mounted in a removable solid aluminium block, which functions as a heatsink and rigid optical mount. Dims of block are 50 w x 50 d x 15 h mm. Integral features include over temperature shutdown, current control, laser OK output, and gated TTL ON / OFF. Many uses for experimental optics, comms & lightshows etc. Supplied complete with data sheet.
Order as TD91 **ONLY £24.95 (A)**

DC POWER SUPPLIES

Virtually every type of power supply you can imagine. Over 10,000 Power Supplies Ex Stock - Call or see our web site.

RELAYS - 200,000 FROM STOCK

Save £££'s by choosing your next relay from our Massive Stocks covering types such as Military, Octal, Cradle, Hermetically Sealed, Continental, Contactors, Time Delay, Reed, Mercury Wetted, Solid State, Printed Circuit Mounting etc. Call or see our web site www.distel.co.uk for more information. Many obsolete types from stock. Save £££'s

DISPLAY ELECTRONICS



ALL MAIL TO
Dept PE, 29 / 35 Osborne Rd
Thornton Heath
Surrey CR7 8PD
Open Mon - Fri 9.00 - 5.30

18 Million Items On Line Now!
Secure ordering, Pictures, Information
www.distel.co.uk
email = admin@distel.co.uk

ALL ENQUIRIES
0208 653 3333
FAX 0208 653 8888

All prices for UK Mainland. UK customers add 17.5% VAT to TOTAL order amount. Minimum order £10. Bonus Finance account orders accepted from Government, Schools, Universities and Local Authorities - minimum account order £50. Cheques over £100 are subject to 7 working days clearance. Cartage charges (A)=£3.50, (B)=£6.50, (C)=£10, (D)=£15.00, (E)=£18.00, (F)=CALL. Allow approx 3 days for shipping - faster CALL. All goods supplied to our Standard Conditions of Sale which can be viewed at our website and unless stated guaranteed for 90 days. All guarantees on a return to base basis. All rights reserved to change prices / specifications without prior notice. Orders subject to stock. Discounts for volume. Top CASH prices paid for surplus goods. All trademarks, tradenames etc acknowledged. © Display Electronics 2002. E & O E..

NEXT MONTH

200MHz FUNCTION GENERATOR

One of the most useful facilities in the electronic experimenter's workshop is an ability to generate a.c. test signals of various waveforms, frequencies and amplitudes. This is where this Function Generator project comes in, the "function" in the name referring to the waveform of its output signal. It can be used for testing or driving many circuits, from below audio up to a couple of hundred kilohertz, and may even be used as a variable speed clock for logic circuit testing. It has sine, square and triangle-wave outputs plus a separate 0V to +5V squarewave output for logic driving. This may also be used with a 'sync' input when, for example, inspecting low-level signals on an oscilloscope.

Where a sinewave output is required two function generator i.c.s are generally available, these being the industry standard 8038 and the more recent Maxim MAX038. The latter can operate at frequencies above 20MHz but is still fairly expensive. Also, its sheer speed can make it difficult to work with, especially for the less experienced constructor. For audio and general purpose work at lower frequencies the older 8038 has much to recommend it. Various claims have been made for its maximum operating frequency, up to 1MHz in fact, but 300kHz is more common and the author has tended to regard 100kHz as "top whack" to date. However, this design operates up to 200kHz and the results at this frequency are quite acceptable for most purposes.

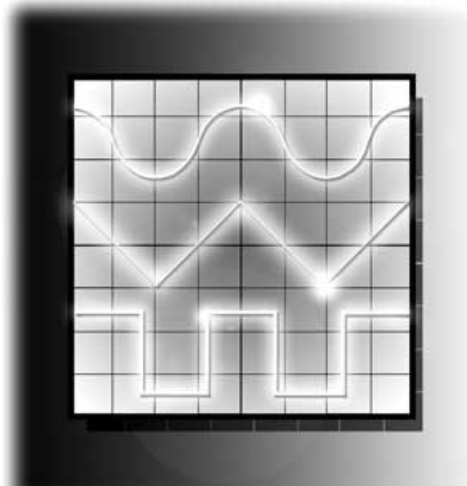

WIND-UP TORCH II

An updated and improved wind-up torch based on the design published in the EPE October 2000 issue. This version is 30% smaller, 120% brighter and 500% quicker to wind up, it also has a visual indication of full charge. The torch uses no batteries – not even rechargeables – and will produce a brightness of about 35 lux at two metres on "high beam" which can light a footpath at night up to seven metres ahead. It should pay for itself in saved batteries within 48 hours of use.

DRIVER ALERT – A THINKING AND REACTION TIME TESTER

Speaking on a mobile phone, including using a hands-free unit, can impair your reactions as much as four cans of strong lager. This Driver Alert, which won the best Under-15s project award at the 2003 YEDA Competition, proves it. Unlike a simple reaction tester, which does not test concentration and thinking time, this easy to build unit will show how these are affected by drink or distractions. It has shown that one can of strong lager can increase (i.e. slower) reaction time by over 30% and talking on a mobile by over 60%.

PLUS

BACK TO BASICS – two more simple, easy to build projects

NO ONE DOES IT BETTER



**DON'T MISS AN
ISSUE – PLACE YOUR
ORDER NOW!**

Demand is bound to be high

MARCH 2003 ISSUE ON SALE THURSDAY, FEBRUARY 13

QUASAR ELECTRONICS LIMITED

PO Box 6935, BISHOPS STORTFORD, Herts. CM23 4WP

TEL: 0871 717 7168 FAX: 0871 277 2728

ADD £2.00 P&P to all orders (or 1st Class Recorded E4, Next day (Insured £250) £7, Europe £5.00, Rest of World £10.00). We accept all major credit cards. Make cheques/PO's payable to Quasar Electronics. Prices include 17.5% VAT. **MAIL ORDER ONLY** FREE CATALOGUE with order or send 2 x 1st class stamps (refundable) for details of over 150 kits & publications.



PROJECT KITS

Our electronic kits are supplied complete with all components, high quality PCBs (NOT cheap Trip board!) and detailed assembly/operating instructions

- **2 x 25W CAR BOOSTER AMPLIFIER** Connects to the output of an existing car stereo cassette player, CD player or radio. Heat sinks provided. PCB 76x75mm. **1046KT £24.95**
- **3-CHANNEL WIRELESS LIGHT MODULATOR** No electrical connection with amplifier. Light modulation achieved via a sensitive electret microphone. Separate sensitivity control per channel. Power handling 400W/channel. PCB 54x112mm. Mains powered. Box provided. **6014KT £24.95**
- **12 RUNNING LIGHT EFFECT** Exciting 12 LED light effect ideal for parties, discos, shop-windows & eye-catching signs. PCB design allows replacement of LEDs with 220V bulbs by inserting 3 TRIACS. Adjustable rotation speed & direction. PCB 54x112mm. **1026KT £15.95**; **BOX (for mains operation) 2026BX £29.00**
- **DISCO STROBE LIGHT** Probably the most exciting of all light effects. Very bright strobe tube. Adjustable strobe frequency. 1-60Hz. Mains powered. PCB: 60x68mm. Box provided. **6037KT £28.95**

- **ANIMAL SOUNDS** Cat, dog, chicken & cow. Ideal for kids farmyard toys & schools. **SG10M £5.95**
- **3 1/2 DIGIT LED PANEL METER** Use for basic voltage/current displays or customise to measure temperature, light, weight, movement, sound levels, etc. with appropriate sensors (not supplied). Various input circuit designs provided. **3061KT £13.95**
- **IR REMOTE TOGGLE SWITCH** Use any TV/VCR remote control unit to switch onboard 12V/1A relay on/off. **3058KT £10.95**
- **SPEED CONTROLLER** for any common DC motor up to 100V/5A. Pulse width modulation gives maximum torque at all speeds. 5-15VDC. Box provided. **3067KT £12.95**
- **3 x 8 CHANNEL IR RELAY BOARD** Control eight 12V/1A relays by Infra Red (IR) remote control over a 20m range in sunlight. 6 relays turn on only, the other 2 toggle on/off. 3 operation ranges determined by jumpers. Transmitter case & all components provided. Receiver PCB 76x69mm. **3072KT £32.95**

PRODUCT FEATURE

COMPUTER TEMPERATURE DATA LOGGER

PC serial port controlled 4-channel temperature meter (either deg C or F). Requires no external power. Allows continuous temperature data logging of up to four temperature sensors located 200m+ from motherboard/PC. Ideal use for old 386/486 computers. Users can tailor input data stream to suit their purpose (dump it to a spreadsheet or write your own BASIC programs using the INPUT command to grab the readings). PCB just 38mm x 38mm. Sensors connect via four 3-pin headers. 4 header cables supplied but only one DS18S20 sensor. Kit software available free from our website. **ORDERING: 3145KT £23.95** (kit form); **AS3145 £29.95** (assembled); Additional DS18S20 sensors £4.95 each

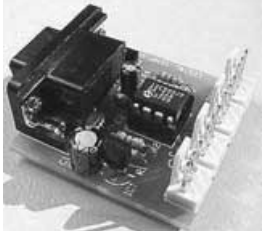

- **SOUND EFFECTS GENERATOR** Easy to build. Create an almost infinite variety of interesting/unusual sound effects from birds chirping to sirens. 9VDC. PCB 54x65mm. **1045KT £9.95**
- **ROBOT VOICE EFFECT** Make your voice sound similar to a robot or Darlek. Great fun for discos, school plays, theatre productions, radio stations & playing jokes on your friends when answering the phone! PCB 42x71mm. **1131KT £8.95**
- **AUDIO TO LIGHT MODULATOR** Controls intensity of one or more lights in response to an audio input. Safe, modern opto-coupler design. Mains voltage experience required. **3012KT £8.95**
- **MUSIC BOX** Activated by light. Plays 8 Christmas songs and 5 other tunes. **3104KT £7.95**
- **30 SECOND VOICE RECORDER** Uses non-volatile memory - no battery backup needed. Record/replay messages over & over. Playback as required to greet customers etc. Volume control & built-in mic. 6VDC. PCB 50x73mm. **3131KT £12.95**
- **TRAIN SOUNDS** 4 selectable sounds: whistle blowing, level crossing bell, 'clackety-clack' & 4 in sequence. **SG01M £6.95**

- **PC CONTROLLED RELAY BOARD** Convert any 286 upward PC into a dedicated automatic controller to independently turn on/off up to eight lights, motors & other devices around the home, office, laboratory or factory. Each relay output is capable of switching 250VAC/4A. A suite of DOS and Windows control programs are provided together with all components (except box and PC cable). 12VDC. PCB 70x200mm. **3074KT £31.95**
- **2 CHANNEL UHF RELAY SWITCH** Contains the same transmitter/receiver pair as 30A15 below plus the components and PCB to control two 240VAC/10A relays (also supplied). Ultra bright LEDs used to indicate relay status. **3082KT £27.95**
- **TRANSMITTER RECEIVER PAIR** 2-button keyfob style. 300-375MHz Tx with 30m range. Receiver encoder module with matched decoder IC. Components must be built into a circuit like kit 3082 above. **30A15 £14.95**
- **PIC 16C71 FOUR SERVO MOTOR DRIVER** Simultaneously control up to 4 servo motors. Software & all components (except servos/control pots) supplied. 5VDC. PCB 50x70mm. **3102KT £15.95**
- **UNIPOLAR STEPPER MOTOR DRIVER** for any 5/6/8 lead motor. Fast/slow & single step rates. Direction control & on/off switch. Wave, 2-phase & half-wave step modes. 4 LED indicators. PCB 50x65mm. **3109KT £14.95**
- **PC CONTROLLED STEPPER MOTOR DRIVER** Control two unipolar stepper motors (3A max. each) via PC printer port. Wave, 2-phase & half-wave step modes. Software accepts 4 digital inputs from external switches & will single step motors. PCB fits in D-shell case provided. **3113KT £15.95**
- **12-BIT PC DATA ACQUISITION/CONTROL UNIT** Similar to kit 3093 above but uses a 12 bit Analogue-to-Digital Converter (ADC) with internal analogue multiplexer. Reads 8 single ended channels of 4 differential inputs or a mixture of both. Analogue inputs read 0-4V. Four TTL/CMOS compatible digital input/outputs. ADC conversion time <10µs. Software (C, QB & Win), extended D shell case & all components (except sensors & cable) provided. **3118KT £52.95**
- **LIQUID LEVEL SENSOR/RAIN ALARM** Will indicate fluid levels or simply the presence of fluid. Relay output to control a pump to add/remove water when it reaches a certain level. **1080KT £5.95**
- **AM RADIO KIT 1** Tuned Radio Frequency front-end, single chip AM radio IC & 2 stages of audio amplification. All components inc. speaker provided. PCB 32x102mm. **3063KT £10.95**
- **DRILL SPEED CONTROLLER** Adjust the speed of your electric drill according to the job at hand. Suitable for 240V AC mains powered drills up to

X-FACTOR PUBLICATIONS

THE EXPERTS IN RARE & UNUSUAL INFORMATION!

Full details of all X-FACTOR PUBLICATIONS can be found in our catalogue. N.B. Minimum order charge for reports and plans is £5.00 PLUS normal P&P.

- **SUPER-EAR LISTENING DEVICE** Complete plans to build your own parabolic dish microphone. Listen to distant voices and sounds through open windows and even walls! Made from readily available materials. **R002 £35.50**
- **LOCKS** - How they work and how to pick them. This fact filled report will teach you more about locks and the art of lock picking than many books we have seen at 4 times the price. Packed with information and illustrations. **R008 £35.50**
- **RADIO & TV JOKER PLANS** We show you how to build three different circuits for disrupting TV picture and sound plus FM radio! May upset your neighbours & the authorities! DISCRETION REQUIRED. **R017 £35.50**
- **INFINITY TRANSMITTER PLANS** Complete plans for building the famous Infinity Transmitter. Once installed on the target phone, device acts like a room bug. Just call the target phone & activate the unit to hear all room sounds. Great for home/office security! **R019 £35.50**
- **THE ETHER BOX CALL INTERCEPTOR PLANS** Grabs telephone calls out of this air! No need to wire-in a phone bug. Simply place this device near the phone lines to hear the conversations taking place! **R025 £30.00**
- **CASH CREATOR BUSINESS REPORTS** Need ideas for making some cash? Well this could be just what you need! You get 40 reports (approx. 800 pages) on floppy disk that give you information on setting up different businesses. You also get valuable reproduction and duplication rights so that you can sell the manuals as you like. **R030 £7.50**

WEB: <http://www.QuasarElectronics.com>
email: epesales@QuasarElectronics.com

SURVEILLANCE

High performance surveillance bugs. Room transmitters supplied with sensitive electret microphone & battery holder/clip. All transmitters can be received on an ordinary VHF-FM radio between 88-108MHz. Available in Kit Form (KT) or Assembled & Tested (AS).

ROOM SURVEILLANCE

- **MTX - MINIATURE 3V TRANSMITTER** Easy to build & guaranteed to transmit 300m @ 3V. Long battery life. 3-5V operation. Only 45x18mm. **B 3007KT £6.95 AS3007 £11.95**
- **MRTX - MINIATURE 9V TRANSMITTER** Our best selling bug. Super sensitive, high power - 500m range @ 9V (over 1km with 18V supply and better aerial). 45x19mm. **3018KIT £7.95 AS3018 £12.95**
- **HPTX - HIGH POWER TRANSMITTER** High performance, 2 stage transmitter gives greater stability & higher quality reception. 100m range 6-12V DC operation. Size 70x15mm. **3032KT £9.95 AS3032 £18.95**
- **MMTX - MICRO-MINIATURE 9V TRANSMITTER** The ultimate bug for its size, performance and price. Just 15x25mm. 500m range @ 9V. Good stability. 6-18V operation. **3051KT £8.95 AS3051 £14.95**
- **VTX - VOICE ACTIVATED TRANSMITTER** Operates only when sounds detected. Low standby current. Variable trigger sensitivity. 500m range. Peaking circuit supplied for maximum RF output. On/off switch. 6V operation. Only 63x38mm. **3028KT £12.95 AS3028 £24.95**
- **HARDWIRED BUG/TWO STATION INTERCOM** Each station has its own amplifier, speaker and mic. Can be set up as either a hard-wired bug or two-station intercom. 10m x 2-core cable supplied. 9V operation. **3021KT £15.95 (kit form only)**
- **TRVS - TAPE RECORDER VOX SWITCH** Used to automatically operate a tape recorder (not supplied) via its REMOTE socket when sounds are detected. All conversations recorded. Adjustable sensitivity & turn-off delay. 115x19mm. **3013KIT £9.95 AS3013 £21.95**

TELEPHONE SURVEILLANCE

- **MTX - MINIATURE TELEPHONE TRANSMITTER** Attaches anywhere to phone line. Transmits info when phone is used. Tune-in your radio and hear both parties. 300m range. Uses line as aerial & power source. 20x45mm. **3016KIT £8.95 AS3016 £14.95**
- **TRV - TELEPHONE RECORDING INTERFACE** Automatically record all conversations. Connects between phone line & tape recorder (not supplied). Operates recordings with 1.5-12V battery systems. Powered from line. 50x33mm. **3033KIT £9.95 AS3033 £18.95**
- **TPA - TELEPHONE PICK-UP AMPLIFIER/WIRELESS PHONE BUG** Place pick-up coil on the phone line or near phone earpiece and hear both sides of the conversation. **3055KIT £11.95 AS3055 £20.95**

HIGH POWER TRANSMITTERS

- **1 WATT FM TRANSMITTER** Easy to construct. Delivers a crisp, clear signal. Two-stage circuit. Kit includes microphone and requires a simple open dipole aerial. 8-30VDC. PCB 42x45mm. **1009KT £12.95**
- **4 WATT FM TRANSMITTER** Comprises three RF stages and an audio preamplifier stage. Piezoelectric microphone supplied or you can use a separate preamplifier circuit. Antenna can be an open dipole or Ground Plane. Ideal project for those who wish to get started in the fascinating world of FM broadcasting and want a good basic circuit to experiment with. 12-18VDC. PCB 44x146mm. **1028KT £22.95 AS1028 £34.95**
- **15 WATT FM TRANSMITTER (PRE-ASSEMBLED & TESTED)** Four transistor based stages with Philips BLY 88 in final stage. 15 Watts RF power on the air. 88-108MHz. Access open dipole. Ground Plane. 5/8, J, or YAGI antennas. 12-18VDC. PCB 70x220mm. SWS meter needed for alignment. **1021KT £99.95**
- **SIMILAR TO ABOVE BUT 25W Output.** **1031KT £109.95**

- **700W power.** PCB: 48mm x 65mm. Box provided. **6074KT £17.95**
- **3 INPUT MONO MIXER** Independent level control for each input and separate bass/treble controls. Input sensitivity: 240mV. 18V DC. PCB: 60mm x 185mm **1052KT £16.95**
- **NEGATIVE/POSITIVE ION GENERATOR** Standard Cockcroft-Walton multiplier circuit. Mains voltage experience required. **3057KT £10.95**
- **LED DICE** Classic intro to electronics & circuit analysis. 7 LEDs simulate dice roll, slow down & land on a number at random. 555 IC circuit. **3003KT £9.95**
- **STAIRWAY TO HEAVEN** Tests hand-eye co-ordination. Press switch when green segment of LED lights to climb the stairway - miss & start again! Good intro to several basic circuits. **3005KT £9.95**
- **ROULETTE LED 'Ball'** spins round the wheel, slows down & drops into a slot. 10 LEDs. Good intro to CMOS decade counters & Op-Amps. **3006KT £10.95**
- **12V XENON TUBE FLASHER TRANSFORMER** steps up a12V supply to flash a 25mm Xenon tube. Adjustable flash rate. **3163KT £13.95**
- **LED FLASHER 1** 5 ultra bright red LED's flash in 7 selectable patterns. **3037MKT £5.95**
- **LED FLASHER 2** Similar to above but flash in sequence or randomly. Ideal for model railways. **3052MKT £5.95**
- **INTRODUCTION TO PIC PROGRAMMING.** Learn programming from scratch. Programming hardware, a P16F84 chip and a two-part, practical, hands-on tutorial series are provided. **3081KT £21.95**
- **SERIAL PIC PROGRAMMER** for all 818/28/40 pin DIP serial programmed PICs. Shareware software supplied limited to programming 256 bytes (registration costs £14.95). **3096KT £10.95**
- **ATMEL 89C4051 PROGRAMMER** Simple-to-use yet powerful programmer for the Atmel 89C1051, 89C2051 & 89C4051 uC's. Programmer does NOT require special software other than a terminal emulator program (built into Windows). Can be used with ANY computer/operating system. **3121KIT £24.95**
- **3V/1-5V TO 9V BATTERY CONVERTER** Replace expensive 9V batteries with economic 1.5V batteries. IC based circuit steps up 1 or 2 'AA' batteries to give 9V/18mA. **3035KIT £5.95**
- **STABILISED POWER SUPPLY 3-30V/2.5A** Ideal for hobbyist & professional laboratory. Very reliable & versatile design at an extremely reasonable price. Short circuit protection. Variable DC voltages (3-30V). Rated output 2.5 Amps. Large heatsink included. You just supply a 24VAC/3A transformer. PCB 55x112mm. Mains operation. **1007KT £16.95.**

- **STABILISED POWER SUPPLY 2-30V/5A** As kit 1007 above but rated at 5Amp. Requires a 24VAC/5A transformer. **1096KT £27.95.**
- **MOTORBIKE ALARM** Uses a reliable vibration sensor (adjustable sensitivity) to detect movement of the bike to trigger the alarm & switch the output relay to which a siren, bikes horn, indicators or other warning device can be attached. Auto-reset. 6-12VDC. PCB 57x64mm. **1011KT £11.95 Box 2011BX £7.00**
- **CAR ALARM SYSTEM** Protect your car from theft. Features vibration sensor, courtesy/boot light voltage drop sensor and bonnet/booth switch sensor. Entry/exit delays, auto-reset and adjustable alarm duration. 6-12V DC. PCB: 47mm x 55mm **1019KIT £11.95 Box 2019BX £8.00**
- **PIEZO SCREAMER 1** 10dB of ear piercing noise. Fits in box with 2 x 35mm piezo elements built into their own resonant cavity. Use as an alarm siren or just for fun! 6-9VDC. **3015KT £10.95**
- **COMBINATION LOCK** Versatile electronic lock comprising main circuit & separate keypad for remote opening of lock. Relay supplied. **3029KT £10.95**
- **ULTRASONIC MOVEMENT DETECTOR** Crystal locked detector frequency for stability & reliability. PCB 75x40mm houses all components. 4-7m range. Adjustable sensitivity. Output will drive external relay/circuits. 9VDC. **3049KIT £13.95**
- **PIR DETECTOR MODULE** 3-lead assembled unit just 25x35mm as used in commercial burglar alarm systems. **3076KT £8.95**
- **INFRARED SECURITY BEAM** When the invisible IR beam is broken a relay is tripped that can be used to sound a bell or alarm. 25 metre range. Mains rated relays provided. 12VDC operation. **3130KT £12.95**
- **SQUARE WAVE OSCILLATOR** Generates square waves at 6 preset frequencies in factors of 10 from 1Hz-100KHz. Visual output indicator. 5-18VDC. Box provided. **3111KT £8.95**
- **PC DRIVEN POCKET SAMPLER/DATA LOGGER** Analogue voltage sampler records voltages up to 2V or 20V over periods from milli-seconds to months. Can also be used as a simple digital scope to examine audio & other signals up to about 5KHz. Software & D-shell case provided. **3112KT £18.95**
- **20 MHz FUNCTION GENERATOR** Square, triangular & sine waveform up to 20MHz over 3 ranges using 'coarse' and 'fine' frequency adjustment controls. Adjustable output from 0-2V p-p. A TTL output is also provided for connection to a frequency meter. Uses MAX039 IC. Plastic case with printed front/rear panels & all components provided. 7-12VAC. **3101KT £69.95**

BARGAIN BUY!

Great introduction to electronics. Ideal for the budding electronics expert! Build a radio, burglar alarm, water detector, Morse code practice circuit, simple computer circuits, and much more! NO soldering, tools or previous electronics knowledge required. Circuits can be built and unassembled repeatedly. Comprehensive 68-page manual with explanations, schematics and assembly diagrams. Suitable for age 10+. Excellent for schools. Requires 2 x AA batteries. Order Code EPL030 **ONLY £14.95** (phone for bulk discounts). 130, 300 and 500-in-ONE also available.

30-in-ONE Electronic Projects Lab



Secure Online Ordering Facilities
Full Kit Listing, Descriptions & Photos
Kit Documentation & Software Downloads

www.QuasarElectronics.com

Credit Card Sales: 0871 717 7168

SQUIRES MODEL & CRAFT TOOLS

ANTEX SOLDERING STATIONS

ANTEX 660TC

- * Temperature control range 65 - 450°C
- * Thumb wheel potentiometer control
- * 50 Watt Iron Included (25W Optional Extra)
- * Wide range of spare bits available (0.5mm - 6.0mm)



Normal Price ~~£114.95~~ - Now **£89.95**
Post Free to UK addresses.

ANTEX 690SD

- * Temperature control range 65 - 450°C
- * Digital readout temperature control
- * 50 Watt static dissipative iron included
- * Wide range of spare bits available (0.5mm - 6.0mm)



Normal Price ~~£169.95~~ - Now **£129.95**
Post Free to UK addresses.

Post, Telephone or Fax your orders to:-

Squires, 100 London Road, Bognor Regis, West Sussex, PO21 1DD
Tel 01243 842424 Fax 01243 842525

OUR 600 PAGE POST FREE MAIL ORDER CATALOGUE IS AVAILABLE FREE OF CHARGE TO ADDRESS IN THE UK - OVERSEAS CATALOGUE FREE, POSTAGE CHARGED AT COST TO CREDIT CARD



Shop Open 9 - 5.30 Monday - Friday, 9- 5 Saturday



SPECIAL OFFERS



TEKTRONIX 2445A
4-ch 150MHz delay, cursors etc. Supplied with 2 Tektronix probes.
ONLY **£425**

TEKTRONIX 2232 Digital Storage Scope. Dual Trace, 100MHz, 100M/S with probes £525
H.P. 54501A Dig. Oscilloscope, 100MHz 4-Ch £425
H.P. 3312A Function Gen., 0-1Hz-13MHz, AM/FM Sweep/Tri/Gate/Bst etc. £300
FARNELL Dual PSU XA35-2T, 0-35V, 0-2A, Twice QMD, I.c.d. Display £180
CIRIUS CRL254 Sound Level Meter with Calibrator 90-120dB, LEO £150
FARNELL ANM255 Automatic Meter, 1-5MHz-2GHz, unused £300
FARNELL DSG1 Low Frequency Syn Sig. Gen., 0-001Hz-99.99kHz, low distortion, TTL/Square/Pulse Outputs etc. £95
FLUKE 8060A Handheld True RMS, DMM, 4 1/2 digit As new £150, used £95
BECKMAN HD110 Handheld 3 1/2 digit DMM, 28 ranges, with battery, leads and carrying case. £40

H.P. 3310A Function Gen., 0-005Hz-5MHz, Sine/Sq/Tri/Ramp/Pulse £125
FARNELL LFM4 Sine/Sq Oscillator, 10Hz-1MHz, low distortion, TTL output, Amplitude Meter £125
H.P. 545A Logic Probe with 546A Logic Pulser and 547A Current Tracer £90
FLUKE 77 Multimeter, 3 1/2-digit, handheld £60
FLUKE 77 Series 11 £70
HEME 1000 L.C.D. Clamp Meter, 00-1000A, in carrying case £60

BLACK STAR ORION PAL/TV Colour Pattern Generator, 4-5 digit, from £75-£125
THURLEY/THANDER TG210 Function Generator, 0.002Hz-2MHz, TTL etc. £80-£95
THURLEY THANDER P.S.U. PL320QMD, 0V-32V, 0A-2A Twice (late colours) £200

Datron 1061 ONLY **£150**
High Quality 5.5 Digit Bench Multimeter
True RMS/4 wire Res/Current Converter/IEEE

Datron 1061A ONLY **£225**
High Quality 6 1/2 digit Bench Multimeter
True RMS/4 wire/Current Converter

Racal Receiver RA1772 ONLY **£250**
50kHz-30MHz
L.E.D. Display, Basically working.

MARCONI 2019A



AM/FM SYNTHESISED SIGNAL GENERATOR
80 kHz - 1040MHz
NOW ONLY **£400**

MARCONI 893C AF Power Meter, Sinal Measurement Unused £100, Used £50

MARCONI 893B, No Sinad £30
MARCONI 2610 True RMS Voltmeter, Autorangeing, 5Hz-25MHz £195

GOULD J3B Sine/Sq Osc., 10Hz-100kHz, low distortion £75-£125
AVO 8 Mk. 6 in Every Ready case, with leads etc. £80
Other AVOs from £50

GOODWILL GVT427 Dual Ch AC Millivoltmeter, 10mV-300V in 12 ranges, Freq. 10Hz-1MHz. £100-£125
SOLARTRON 7150 DMM 6 1/2-digit Tru RMS-IEEE £95-£150
SOLARTRON 7150 Plus £200

HIGH QUALITY RACAL COUNTERS

9904 Universal Timer Counter, 50MHz £50
9918 Counter, 10Hz-520MHz £75
9918 Counter, 10Hz-560MHz, 9-digit £50
WAYNE KERR B424 Component Bridge £125
RACAL/AIM 9343M LCR Databridge, Digital Automeasurement of R, C, L, Q, D £200
HUNTRON TRACKER Model 1000 £125
FLUKE 8050A 4.5 Digit 2A, True RMS £75
FLUKE 8010A 3.5 Digit, 10A £50
FLUKE 8012A 3.5 Digit, 2A £40

Racal 9008 ONLY **£95**
Automatic Modulation Meter, AM/FM 1-5MHz-2GHz

Portable Appliance Tester ONLY **£180**
Megger Pat 2

H.P. 6012B DC PSU 0-60V, 0-50A, 1000W £1000
FARNELL AP60/50 1KW Autorangeing £1000
FARNELL H60150 0-60V 0-50A £750
FARNELL H60/25 0-60V 0.25A £400
Power Supply HPS3010, 0-30V, 0-10A £140
FARNELL L30-2 0-30V, 0-2A £80
FARNELL L30-1 0-30V, 0-1A £60
Many other Power Supplies available

FARNELL DTV12-14 OSCILLOSCOPE

Dual trace, 12MHz TV, coupling ONLY **£75**

FARNELL LF1 SINE/SQ OSCILLATOR ONLY **£75**
10Hz-1MHz.

OSCILLOSCOPES

TEKTRONIX TDS350 dual trace, 200MHz, 1G/S, Unused £1500
TEKTRONIX TDS320 dual trace, 100MHz, 500M/S £1200
TEKTRONIX TDS510 dual trace, 50MHz, 200M/S £950
LECROY 9400A dual trace, 175MHz, 50/S £750
HITACHI VC6523, d'trace, 20MHz, 20M/S, delay etc. Unused £500
PHILIPS PM3092 2+2-ch., 200MHz, delay etc. £800 as new £950
PHILIPS PM3082 2+2-ch., 100MHz, delay etc. £700 as new £800
TEKTRONIX TAS465 dual trace, 100MHz, delay etc. £750
TEKTRONIX 2465S 4-ch., 400MHz, delay cursors etc £1500
TEKTRONIX 2465 4-ch., 300MHz, delay cursors etc. £900
TEKTRONIX 468 Dig. Storage, dual trace, 100MHz, delay £450
TEKTRONIX 466 Analogue Storage, dual trace, 100MHz £250
TEKTRONIX 485 dual trace, 350MHz, delay sweep £550
TEKTRONIX 475 dual trace, 200MHz, delay sweep £350
TEKTRONIX 465B dual trace, 100MHz, delay sweep £325
TEKTRONIX 2215 dual trace, 60MHz, delay sweep £250
TEKTRONIX 485 dual trace, 350MHz, delay sweep £550
TEKTRONIX 475 dual trace, 200MHz, delay sweep £350
TEKTRONIX 465B dual trace, 100MHz, delay sweep £325
TEKTRONIX 2215 dual trace, 60MHz, delay sweep £250
PHILIPS PM3217 dual trace, 50MHz, delay £200-£250
GOULD 051100 dual trace, 30MHz, delay £125
HAMEG HM303.6 dual trace, 35MHz component tester £240
as new £200
HAMEG HM303 dual trace, 30MHz component tester £200
Many other Oscilloscopes available

MARCONI 2022E Synth AM/FM Sig Gen 10kHz-1.01GHz I.c.d. display etc £525-£750
H.P. 8657A Synth sig gen, 100kHz-1040MHz £2000
H.P. 8658B Synth sig gen, 100kHz-990MHz £1350
H.P. 8656A Synth sig gen, 100kHz-990MHz £995
R&S APN62 Synth, 1Hz-260kHz sig. gen., balanced/unbalanced output, I.c.d. display £425
PHILIPS PM5328 sig gen, 100kHz-180MHz with 200MHz, freq. counter, IEEE £550
RACAL 9081 Synth AM/FM sig gen, 5kHz-102MHz £250
H.P. 3325A Synth function gen., 21MHz £600
MARCONI 6500 Amplitude Analyser £1500
H.P. 4192A Impedance Analyser £5000
H.P. 4275A LCR Meter, 10kHz-10MHz £2750
H.P. 8903A Distortion Analyser £1000
WAYNE KERR 3245 Inductance Analyser £2000
H.P. 8112A Pulse Generator, 50MHz £1250
MARCONI 2440 Frequency Counter, 20MHz £1000
H.P. 3550B Frequency Counter, 20GHz £2000
H.P. 5342A 10Hz-16GHz Frequency Counter £800
H.P. 1650B Logic Analyser, 80-channel £1000
MARCONI 2035 Mod Meter, 500kHz-2GHz £750

RADIO COMMUNICATIONS TEST SETS
MARCONI 2955/2955A From £1500
ROHDE & SCHWARZ CMT 0.1-1000MHz £2000
SCHLUMBERGER 4040 £900

JUST IN

H.P. 8063B DC Electronic Load, 3-240V/0-10A, 250W POA
H.P. 66312A PSU 0-20V/0-2A £400
H.P. 66311B PSU 0-15V/0-3A £400
H.P. 66309D PSU Dual, 0-15, 0-3A/0-12, 0-15A £750
H.P. 6632B PSU, 0-20V/0-5A £500
H.P. 6623A PSU, triple output ranging from 0-7V 0-5A to 0-20V 0-4A £850
H.P./AGILENT 34401A DMM 6 1/2 digit £4000-£450
H.P. 3478A DMM 5 1/2 digit £275
FLUKE 45 DMM dual display £400
KEITHLEY 2010 DMM 7 1/2 digit £950
KEITHLEY 617 Programmable Electrometer £1250
H.P. 4338B Milliohmmeter £1500
RACAL Counter type 1999 2.6GHz £500
H.P. Counter type 53131A 3GHz £850
H.P./AGILENT 33120A Func. Gen./ARB, 100Hz-15MHz £900/£1000
SONY/TEKTRONIX AF320 Arbitrary Func. Gen £1250
H.P. 8904A Synth. Function Gen, DC-600kHz £1000/£1250
BLACK STAR JUPITOR 2010 Func. Gen, 0-2Hz-2MHz with frequency counter £140
H.P. 8116A Pulse Generator, 1mH-50MHz £1950
H.P. 8657B Synth Sig. Gen., 0-1-2080MHz £2500
COAXIAL SWITCH, 1.5GHz £40
IEEE CABLES £10

SPECTRUM ANALYSERS

H.P. 8561B 50Hz-6.5GHz £5000
H.P. 8560A 50Hz-2.9GHz synthesised £5000
H.P. 8594E 9kHz-2.9GHz £4500
H.P. 8591E 1MHz-1.8GHz, 75 Ohm £2750
H.P. 853A with 8559A 100kHz-21GHz £1750
H.P. 8558B with Main Frame, 100kHz-1500MHz £750
H.P. 3865A 20Hz-40MHz £2500
H.P. 3850A 5Hz-50MHz £900
ADVANTEST RA131B 10kHz-3.5GHz £2750
EATON/AILTECH 757 0.01-22GHz £750
MARCONI 2382 100Hz-400MHz, high resolution £2000
MARCONI 2370 30Hz-110MHz from £500
H.P. 182 with 8557 10kHz-350MHz £500
H.P. 141T SYSTEMS
8555 1kHz-110MHz £500
8554 500kHz-1250MHz £750
8555 10MHz-16GHz £1000
H.P. 8443 Tracking Gen/Counter, 110MHz £250
H.P. 8444 OPT 059 £750
B&K 2033R Signal Analyser £650
H.P. 8754A Network Analyser, 4MHz-1300MHz £1250
H.P. 3557A Network Analyser, 5Hz-200MHz £3000
H.P. 53510A Mod Domain Analyser Opt 001/003 £5000
ONO SOKKI CF300 Portable FFT Analyser £1500
H.P. 8720C Microwave Network Analyser, 50MHz-20GHz £12,500

STEWART OF READING

110 WYKEHAM ROAD, READING, BERKS. RG6 1PL
Telephone: (0118) 9268041. Fax: (0118) 9351696
www.stewart-of-reading.co.uk

Callers welcome 9am-5.30pm Monday to Friday (other times by arrangement)

Used Equipment - GUARANTEED. Manuals supplied

This is a VERY SMALL SAMPLE OF STOCK. SAE or Telephone for lists.
Please check availability before ordering.
CARRIAGE all units £16. VAT to be added to Total of Goods and Carriage

Learn About Microcontrollers

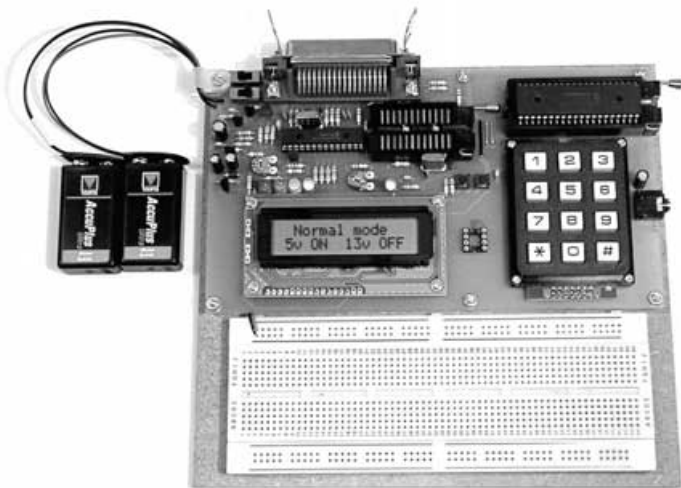

PIC Training & Development System

The best place to start learning about microcontrollers is the PIC16F84. This is easy to understand and very popular with construction projects. Then continue on using the more sophisticated PIC16F877 family.

The heart of our system is a real book which lies open on your desk while you use your computer to type in the programme and control the hardware. Start with four very simple programmes. Run the simulator to see how they work. Test them with real hardware. Follow on with a little theory.....

Our complete PIC training and development system consists of our universal mid range PIC programmer, a 306 page book covering the PIC16F84, a 262 page book introducing the PIC16F877 family, and a suite of programmes to run on a PC. The module is an advanced design using a 28 pin PIC16F872 to handle the timing, programming and voltage switching requirements. The module has two ZIF sockets and an 8 pin socket which between them allow most mid range 8, 18, 28 and 40 pin PICs to be programmed. The plugboard is wired with a 5 volt supply. The software is an integrated system comprising a text editor, assembler disassembler, simulator and programming software. The programming is performed at normal 5 volts and then verified with plus and minus 10% applied to ensure that the device is programmed with a good margin and not poised on the edge of failure. Requires two PP3 batteries which are not supplied.

- Universal mid range PIC programmer module
- + Book Experimenting with PIC Microcontrollers
- + Book Experimenting with the PIC16F877 (2nd edition)
- + Universal mid range PIC software suite
-+ PIC16F84 and PIC16F872 test PICs. £157.41
- UK Postage and insurance. £ 7.50
- (Europe postage & Insurance. . £13.00. Rest of world. . £24.00)

Experimenting with PIC Microcontrollers

This book introduces the PIC16F84 and PIC16C711, and is the easy way to get started for anyone who is new to PIC programming. We begin with four simple experiments, the first of which is explained over ten and a half pages assuming no starting knowledge except the ability to operate a PC. Then having gained some practical experience we study the basic principles of PIC programming, learn about the 8 bit timer, how to drive the liquid crystal display, create a real time clock, experiment with the watchdog timer, sleep mode, beeps and music, including a rendition of Beethoven's *Für Elise*. Finally there are two projects to work through, using the PIC16F84 to create a sinewave generator and investigating the power taken by domestic appliances. In the space of 24 experiments, two projects and 56 exercises the book works through from absolute beginner to experienced engineer level.

Ordering Information

Telephone with Visa, Mastercard or Switch, or send cheque/PO for immediate despatch. All prices include VAT if applicable. Postage must be added to all orders. UK postage £2.50 per book, £1.00 per kit, maximum £7.50. Europe postage £3.50 per book, £1.50 per kit. Rest of World £6.50 per book, 2.50 per kit.

Web site:- www.brunningsoftware.co.uk

NEW 32 bit PC Assembler

Experimenting with PC Computers with its kit is the easiest way ever to learn assembly language programming. If you have enough intelligence to understand the English language and you can operate a PC computer then you have all the necessary background knowledge. Flashing LEDs, digital to analogue converters, simple oscilloscope, charging curves, temperature graphs and audio digitising. Kit now supplied with our 32 bit assembler with 84 page supplement detailing the new features and including 7 experiments PC to PIC communication. Flashing LEDs, writing to LCD and two way data using 3 wires from PC's parallel port to PIC16F84.

- Book Experimenting with PCs £21.50
- Kit 1a 'made up' with software £52.00
- Kit 1u 'unmade' with software £45.00

C & C++ for the PC

Experimenting with C & C++ Programmes teaches us to programme by using C to drive the simple hardware circuits built using the materials supplied in the kit. The circuits build up to a storage oscilloscope using relatively simple C techniques to construct a programme that is by no means simple. When approached in this way C is only marginally more difficult than BASIC and infinitely more powerful. C programmers are always in demand. Ideal for absolute beginners and experienced programmers.

- Book Experimenting with C & C++ £24.99
- Kit CP2a 'made up' with software £32.51
- Kit CP2u 'unmade' with software £26.51
- Kit CP2t 'top up' with software £12.99

The Kits

The assembler and C & C++ kits contain the prototyping board, lead assemblies, components and programming software to do all the experiments. The 'made up' kits are supplied ready to start. The 'top up' kit is for readers who have already purchased kit 1a or 1u. The kits do not include the book.

Hardware required

All systems in this advertisement assume you have a PC (386 or better) and a printer lead. The experiments require no soldering.

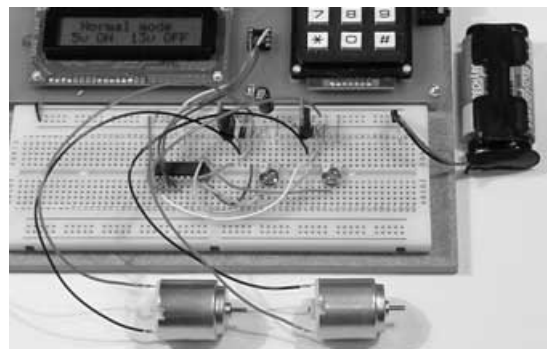

Experimenting with the PIC16F877

The second PIC book starts with the simplest of experiments to give us a basic understanding of the PIC16F877 family. Then we look at the 16 bit timer, efficient storage and display of text messages, simple frequency counter, use a keypad for numbers, letters and security codes, and examine the 10 bit A/D converter.

The 2nd edition has two new chapters. The PIC16F627 is introduced as a low cost PIC16F84. We use the PIC16F627 as a step up switching regulator, and to control the speed of a DC motor with maximum torque still available. Then we study how to use a PIC to switch mains power using an optoisolated triac driving a high current triac.

Mail order address:

Brunning Software 138 The Street, Little Clacton, Clacton-on-sea, Essex, CO16 9LS. Tel 01255 862308

MAIL ORDER ONLY • CALLERS BY APPOINTMENT

EPE PROJECT PICS

Programmed PICs for *EPE Projects
 12C508/9 - £3.90; 16F627/8 - £4.90
 16C84/16F84/16C71 - £5.90
 16F876/877 - £10.00
 All inc. VAT and Postage
 (*Some projects are copyright)

EPE MICROCONTROLLER P.I. TREASURE HUNTER

The latest MAGENTA DESIGN - highly stable & sensitive - with I.C. control of all timing functions and advanced pulse separation techniques.

- High stability drift cancelling
- Easy to build & use
- No ground effect, works in seawater



- Detects gold, silver, ferrous & non-ferrous metals

- Efficient quartz controlled microcontroller pulse generation.
- Full kit with headphones & all hardware

KIT 847 £63.95

PIC PIPE DESCALER

- SIMPLE TO BUILD
- HIGH POWER OUTPUT
- AUDIO & VISUAL MONITORING
- SWEPT FREQUENCY

An affordable circuit which sweeps the incoming water supply with variable frequency electromagnetic signals. May reduce scale formation, dissolve existing scale and improve lathering ability by altering the way salts in the water behave. Kit includes case, P.C.B., coupling coil and all components. High coil current ensures maximum effect. L.E.D. monitor.



KIT 868 £22.95 POWER UNIT.....£3.99

MICRO PEST SCARER

Our latest design - The ultimate scarer for the garden. Uses special microchip to give random delay and pulse time. Easy to build reliable circuit. Keeps pets/pests away from newly sown areas, play areas, etc. uses power source from 9 to 24 volts.

- RANDOM PULSES
- HIGH POWER
- DUAL OPTION



Plug-in power supply £4.99

KIT 867.....£19.99

KIT + SLAVE UNIT.....£32.50

WINDICATOR

A novel wind speed indicator with LED readout. Kit comes complete with sensor cups, and weatherproof sensing head. Mains power unit £5.99 extra.

KIT 856.....£28.00

★ TENS UNIT ★

DUAL OUTPUT TENS UNIT

As featured in March '97 issue.

Magenta have prepared a FULL KIT for this excellent new project. All components, PCB, hardware and electrodes are included. Designed for simple assembly and testing and providing high level dual output drive.

KIT 866. . Full kit including four electrodes £32.90

Set of 4 spare electrodes £6.50

68000 DEVELOPMENT TRAINING KIT

- NEW PCB DESIGN
- 8MHz 68000 16-BIT BUS
- MANUAL AND SOFTWARE
- 2 SERIAL PORTS
- PIT AND I/O PORT OPTIONS
- 12C PORT OPTIONS



KIT 621

£99.95

- ON BOARD 5V REGULATOR
- PSU £6.99
- SERIAL LEAD £3.99

Stepping Motors

MD100...Std 100 step...£9.99

MD200...200 step...£12.99

MD24...Large 200 step...£22.95



1000V & 500V INSULATION TESTER

Superb new design. Regulated output, efficient circuit. Dual-scale meter, compact case. Reads up to 200 Megohms.

Kit includes wound coil, cut-out case, meter scale, PCB & ALL components.

KIT 848..... £32.95

MOSFET MKII VARIABLE BENCH POWER SUPPLY 0-25V 2.5A

Based on our Mk1 design and preserving all the features, but now with switching pre-regulator for much higher efficiency. Panel meters indicate Volts and Amps. Fully variable down to zero. Toroidal mains transformer. Kit includes punched and printed case and all parts. As featured in April 1994 EPE. An essential piece of equipment.



Kit No. 845 £64.95

ULTRASONIC PEST SCARER

Keep pets/pests away from newly sown areas, fruit, vegetable and flower beds, children's play areas, patios etc. This project produces intense pulses of ultrasound which deter visiting animals.

- KIT INCLUDES ALL COMPONENTS, PCB & CASE
- EFFICIENT 100V TRANSDUCER OUTPUT
- COMPLETELY INAUDIBLE TO HUMANS
- UP TO 4 METRES RANGE
- LOW CURRENT DRAIN



KIT 812..... £15.00

EPE TEACH-IN 2000

Full set of top quality NEW components for this educational series. All parts as specified by EPE. Kit includes breadboard, wire, croc clips, pins and all components for experiments, as listed in introduction to Part 1.

*Batteries and tools not included.

TEACH-IN 2000 -

KIT 879 £44.95

MULTIMETER £14.45

SPACEWRITER

An innovative and exciting project. Wave the wand through the air and your message appears. Programmable to hold any message up to 16 digits long. Comes pre-loaded with "MERRY XMAS". Kit includes PCB, all components & tube plus instructions for message loading.

KIT 849£16.99

12V EPROM ERASER

A safe low cost eraser for up to 4 EPROMS at a time in less than 20 minutes. Operates from a 12V supply (400mA). Used extensively for mobile work - updating equipment in the field etc. Also in educational situations where mains supplies are not allowed. Safety interlock prevents contact with UV.

KIT 790£29.90

SUPER BAT DETECTOR

1 WATT O/P, BUILT IN SPEAKER, COMPACT CASE 20kHz-140kHz NEW DESIGN WITH 40kHz MIC.

A new circuit using a 'full-bridge' audio amplifier i.c., internal speaker, and headphone/tape socket. The latest sensitive transducer, and 'double balanced mixer' give a stable, high performance superheterodyne design.

KIT 861£24.99

ALSO AVAILABLE Built & Tested... £39.99



SIMPLE PIC PROGRAMMER

KIT 857... £12.99

Includes PIC16F84 chip disk, lead, plug, p.c.b., all components and instructions

Extra 16F84 chips £3.84 Power Supply £3.99

MAGENTA BRAINBOT I & II

- Full kit with ALL hardware and electronics
- As featured in *EPE* Feb '03 – KIT 910
- Seeks light, beeps, avoids obstacles
- Spins and reverses when 'cornered'
- Uses 8-pin PIC
- ALSO KIT 911 – As 910 PLUS programmable from PC serial port – leads and software CD provided

NEW



KIT 910 £16.99 KIT 911 £24.99

PIC 16F84 MAINS POWER 4-CHANNEL CONTROLLER & LIGHT CHASER

- ZERO VOLT SWITCHING
- OPTO ISOLATED 5 Amp
- 12 KEYPAD CONTROL
- HARD-FIRED TRIACS
- WITH SOURCE CODE
- SPEED & DIMMING POT.
- EASILY PROGRAMMED

Kit 855 £39.95

PIC 16F84 LCD DISPLAY DRIVER

INCLUDES 1-PIC16F84 WITH DEMO PROGRAM SOFTWARE DISK, PCB, INSTRUCTIONS AND 16-CHARACTER 2-LINE LCD DISPLAY

Kit 860 £19.99

Power Supply £3.99

FULL PROGRAM SOURCE CODE SUPPLIED – DEVELOP YOUR OWN APPLICATION!

Another super PIC project from Magenta. Supplied with PCB, industry standard 2-LINE x 16-character display, data, all components, and software to include in your own programs. Ideal development base for meters, terminals, calculators, counters, timers – Just waiting for your application!

8-CHANNEL DATA LOGGER

As featured in Aug./Sept. '99 *EPE*. Full kit with Magenta redesigned PCB – LCD fits directly on board. Use as Data Logger or as a test bed for many other 16F877 projects. Kit includes programmed chip, 8 EEPROMs, PCB, case and all components.

KIT 877 £49.95 inc. 8 x 256K EEPROMS

ICEBREAKER

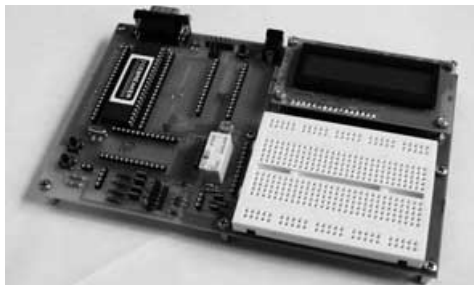

PIC Real Time In-Circuit Emulator

- Icebreaker uses PIC16F877 in circuit debugger
- Links to Standard PC Serial Port (lead supplied)
- Windows™ (95+) Software included
- Works with MPASM and MPLAB Microchip software
- 16 x 2 L.C.D., Breadboard, Relay, I/O devices and patch leads supplied

As featured in March '00 *EPE*. Ideal for beginners AND advanced users. Programs can be written, assembled, downloaded into the microcontroller and run at full speed (up to 20MHz), or one step at a time. Full emulation means that all I/O ports respond exactly and immediately, reading and driving external hardware.

Features include: Reset; Halt on external pulse; Set Breakpoint; Examine and Change registers, EEPROM and program memory; Load program, Single Step with display of Status, W register, Program counter, and user selected 'Watch Window' registers.

KIT 900 ... £34.99

POWER SUPPLY £3.99 STEPPING MOTOR 100 STEP £9.99

EPE PIC TOOLKIT 3

NEW

- THE LATEST TOOLKIT BOARD – 8, 18, 28 AND 40-PIN CHIPS
- MAGENTA DESIGNED P.C.B. WITH COMPONENT LAYOUT AND EXTRAS
- L.C.D., BREADBOARD AND PIC CHIP INCLUDED
- ALL TOP QUALITY COMPONENTS AND SOFTWARE SUPPLIED

KIT 880 ... £34.99 with 16F84 ... £39.99 with 16F877

PIC TOOLKIT V2

- SUPER UPGRADE FROM V1 • 18, 28 AND 40-PIN CHIPS
- READ, WRITE, ASSEMBLE & DISASSEMBLE PICS
- SIMPLE POWER SUPPLY OPTIONS 5V-20V
- ALL SWITCHING UNDER SOFTWARE CONTROL
- MAGENTA DESIGNED PCB HAS TERMINAL PINS AND OSCILLATOR CONNECTIONS FOR ALL CHIPS
- INCLUDES SOFTWARE AND PIC CHIP

KIT 878 ... £22.99 with 16F84 ... £29.99 with 16F877

EPE PIC Tutorial

At last! A Real, Practical, Hands-On Series

- Learn Programming from scratch using PIC16F84
- Start by lighting I.e.d.s and do 30 tutorials to Sound Generation, Data Display, and a Security System.
- PIC TUTOR Board with Switches, I.e.d.s, and on board programmer

PIC TUTOR BOARD KIT

Includes: PIC16F84 Chip, TOP Quality PCB printed with Component Layout and all components* (*not ZIF Socket or Displays). Included with the Magenta Kit is a disk with Test and Demonstration routines.

KIT 870 £27.95, Built & Tested £42.95

Optional: Power Supply – £3.99, ZIF Socket – £9.99

LCD Display £7.99 LED Display £6.99

Reprints Mar/Apr/May 98 – £3.00 set 3

SUPER PIC PROGRAMMER

- READS, PROGRAMS, AND VERIFIES
- WINDOWS® SOFTWARE
- PIC16C AND 16F – 6X, 7X, AND 8X
- USES ANY PC PARALLEL PORT
- USES STANDARD MICROCHIP • HEX FILES
- OPTIONAL DISASSEMBLER SOFTWARE (EXTRA)
- PCB, LEAD, ALL COMPONENTS, TURNED-PIN SOCKETS FOR 18, 28, AND 40 PIN ICs

• SEND FOR DETAILED INFORMATION – A SUPERB PRODUCT AT AN UNBEATABLE LOW PRICE.

Kit 862 £29.99

Power Supply £3.99

DISASSEMBLER SOFTWARE £11.75

PIC STEPPING MOTOR DRIVER

INCLUDES PCB, PIC16F84 WITH DEMO PROGRAM, SOFTWARE DISC, INSTRUCTIONS AND MOTOR.

Kit 863 £18.99

FULL SOURCE CODE SUPPLIED ALSO USE FOR DRIVING OTHER POWER DEVICES e.g. SOLENOIDS

Another Magenta PIC project. Drives any 4-phase unipolar motor – up to 24V and 1A. Kit includes all components and 48 step motor. Chip is pre-programmed with demo software, then write your own, and re-program the same chip! Circuit accepts inputs from switches etc and drives motor in response. Also runs standard demo sequence from memory.

MAGENTA

All prices include VAT. Add £3.00 p&p. Next day £6.99

Tel: 01283 565435 Fax: 01283 546932 E-mail: sales@magenta2000.co.uk

EVERYDAY PRACTICAL ELECTRONICS

THE No.1 MAGAZINE FOR ELECTRONICS TECHNOLOGY & COMPUTER PROJECTS

VOL. 32 No. 2 FEBRUARY 2003

Editorial Offices:
EVERYDAY PRACTICAL ELECTRONICS EDITORIAL
WIMBORNE PUBLISHING LTD., 408 WIMBORNE ROAD EAST,
FERNDOWN, DORSET BH22 9ND
Phone: (01202) 873872. Fax: (01202) 874562.

Email: enquiries@epemag.wimborne.co.uk
Web Site: www.epemag.wimborne.co.uk
EPE Online (downloadable version of *EPE*): www.epemag.com
EPE Online Shop: www.epemag.wimborne.co.uk/shopdoor.htm
See notes on **Readers' Technical Enquiries** below – we regret lengthy technical enquiries cannot be answered over the telephone.

Advertisement Offices:
EVERYDAY PRACTICAL ELECTRONICS ADVERTISEMENTS
MILL LODGE, MILL LANE,
THORPE-LE-SOKEN, ESSEX CO16 0ED
Phone/Fax: (01255) 861161 Email: epeads@aol.com

ROBO

A few years ago we ran a regular Robotics page in the magazine reporting on new robotic arms, buggies, events etc. Eventually we had to discontinue this because of the lack of material, now, however, it looks like robotics is back on the agenda, thanks mainly to programmes like *Robot Wars* on the TV.

We are aware that over the past year there have been a number of robotic events staged by museums, universities and other educational bodies around the country. *RoboFesta UK* (sponsored by the Open University) has been set up to promote science and technology in Britain through robot events and competitions, education and teamwork, their web site shows various robotic events taking place in the UK and also refers to *RoboFesta Europe*, although at the time of writing the site was in need of updating. The web address is www.robofesta-uk.org.

There are various competitions for robots, like the RoboFesta RoboCup Junior Football and the Lunar Rover Competition, also the First Lego League which uses Lego Mindstorms based challenges to promote teamwork and friendly competition.

If you are organising a "robot event" in the future please let us know in good time so we can make readers aware of it.

BRAINIBOT

With this renewed interest in robot building our *Brainibot Buggy* project should go down well, and since it is easy and cheap to build it should be appealing to all hobbyists and students. Depending on the interest shown, this may well be a subject we revisit in the future.

This is, of course, yet another area of electronics that involves computing – in the case of *Brainibot* to program the PIC – and this area in general has been increasingly popular over the last few years. No doubt many computer buffs are getting fed up with simply playing games and want to find out more about the technology inside a PC and, of course, to use their PC in conjunction with add-on or programmable projects.

Brainibot forms an excellent introduction to this, it can be built using the pre-programmed PIC chip, but for anyone who wants to go further the circuit and PIC program can be developed to enable more functions on the simple *Brainibot* chassis.



AVAILABILITY

Copies of *EPE* are available on subscription anywhere in the world (see opposite), from all UK newsagents (distributed by COMAG) and from the following electronic component retailers: Omni Electronics and Yebo Electronics (S. Africa). *EPE* can also be purchased from retail magazine outlets around the world. An Internet on-line version can be purchased and downloaded for just \$10.99US (approx £7) per year available from www.epemag.com

SUBSCRIPTIONS

Subscriptions for delivery direct to any address in the UK: 6 months £15.50, 12 months £29.50, two years £54; Overseas: 6 months £18.50 standard air service or £27.50 express airmail, 12 months £35.50 standard air service or £53 express airmail, 24 months £66 standard air service or £101 express airmail.

Online subscriptions, for downloading the magazine via the Internet, \$10.99US (approx £7) for one year available from www.epemag.com.

Cheques or bank drafts (in £ sterling only) payable to *Everyday Practical Electronics* and sent to EPE Subs. Dept., Wimborne Publishing Ltd, 408 Wimborne Road East, Ferndown, Dorset BH22 9ND. Tel: 01202 873872. Fax: 01202 874562. Email: subs@epemag.wimborne.co.uk. Also via the **Web** at: <http://www.epemag.wimborne.co.uk>. Subscriptions start with the next available issue. We accept MasterCard, Amex, Diners Club, Switch or Visa. (For past issues see the *Back Issues* page.)

BINDERS

Binders to hold one volume (12 issues) are available from the above address. These are finished in blue p.v.c., printed with the magazine logo in gold on the spine. Price £6.95 plus £3.50 p&p (for overseas readers the postage is £6.00 to everywhere except Australia and Papua New Guinea which cost £10.50). Normally sent within seven days but please allow 28 days for delivery – more for overseas.

Payment in £ sterling only please. Visa, Amex, Diners Club, Switch and MasterCard accepted. Send, fax or phone your card number, card expiry date and card security code (the last 3 digits on or just under the signature strip), with your name, address etc. Or order on our secure server via our UK web site. Overseas customers – your credit card will be charged by the card provider in your local currency at the existing exchange rate.

Editor: MIKE KENWARD

Deputy Editor: DAVID BARRINGTON

Technical Editor: JOHN BECKER

Business Manager: DAVID J. LEAVER

Subscriptions: MARILYN GOLDBERG

Administration: FAY KENWARD

Editorial/Admin: (01202) 873872

Advertisement Manager:

PETER J. MEW, Frinton (01255) 861161

Advertisement Copy Controller:

PETER SHERIDAN, (01202) 873872

On-Line Editor: ALAN WINSTANLEY

EPE Online (Internet version) **Editors:**
CLIVE (MAX) MAXFIELD and ALVIN BROWN

READERS' TECHNICAL ENQUIRIES

E-mail: techdept@epemag.wimborne.co.uk

We are unable to offer any advice on the use, purchase, repair or modification of commercial equipment or the incorporation or modification of designs published in the magazine. We regret that we cannot provide data or answer queries on articles or projects that are more than five years old. Letters requiring a personal reply *must* be accompanied by a **stamped self-addressed envelope** or a **self-addressed envelope and international reply coupons**.

PROJECTS AND CIRCUITS

All reasonable precautions are taken to ensure that the advice and data given to readers is reliable. We cannot, however, guarantee it and we cannot accept legal responsibility for it.

A number of projects and circuits published in *EPE* employ voltages that can be lethal. **You should not build, test, modify or renovate any item of mains powered equipment unless you fully understand the safety aspects involved and you use an RCD adaptor.**

COMPONENT SUPPLIES

We do not supply electronic components or kits for building the projects featured, these can be supplied by advertisers (see *Shoptalk*). **We advise readers to check that all parts are still available before commencing any project in a back-dated issue.**

ADVERTISEMENTS

Although the proprietors and staff of EVERYDAY PRACTICAL ELECTRONICS take reasonable precautions to protect the interests of readers by ensuring as far as practicable that advertisements are *bona fide*, the magazine and its Publishers cannot give any undertakings in respect of statements or claims made by advertisers, whether these advertisements are printed as part of the magazine, or in inserts.

The Publishers regret that under no circumstances will the magazine accept liability for non-receipt of goods ordered, or for late delivery, or for faults in manufacture.

TRANSMITTERS/BUGS/TELEPHONE EQUIPMENT

We advise readers that certain items of radio transmitting and telephone equipment which may be advertised in our pages cannot be legally used in the UK. Readers should check the law before buying any transmitting or telephone equipment as a fine, confiscation of equipment and/or imprisonment can result from illegal use or ownership. The laws vary from country to country; readers should check local laws.



BRAINIBOT BUGGY

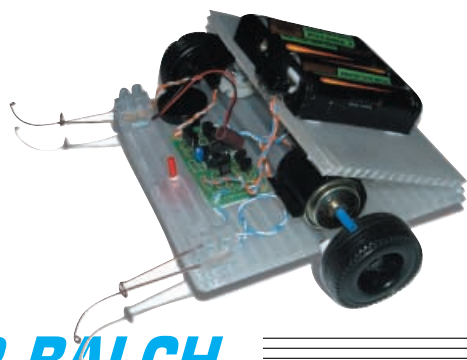

MARK STUART AND PETER BALCH

A low-cost, easy-build buggy that has a mind of its own!

THIS project was designed to provide an interesting and entertaining project for young craft and technology students. At first glance it is a simple two-wheeled buggy, but its responses to signals from its three sensors make it appear to be surprisingly intelligent. The mechanical design described has been kept as simple as possible so that basic components can be used, but other hardware can be adapted to run from the same circuits – providing plenty of room for experiments.

To keep the assembly simple, the electronic control board was designed to use the bare minimum of components, and the smallest PIC microcontroller that would provide sufficient inputs and outputs. The final design uses the PIC12C508 8-pin microcontroller, demonstrates some interesting PIC programming and hardware techniques, and has a performance that would be expected from something much more complicated.

DESIGN

The basis of this project like most other “buggy” designs is a simple two-wheeled chassis stabilised by front and rear “bumpers”. The wheels are driven independently forwards and backwards and

steering is achieved by driving one wheel whilst the other wheel is at rest or driven in the opposite direction.

To provide full bi-directional control of the motors they are driven from a “full bridge” circuit. This means that each motor needs two output pins from the PIC microcontroller. Two more pins of the PIC are used for power, leaving just two pins for the remaining functions.

One of the pins GP3 (Pin 4) is input only, and so is limited in capability. It has an internal pull-up resistor however, and so is used to read one of the “antennae”. The remaining pin, GP2, is more versatile and can be changed between input and output under program control. It is used to read the light sensor, the other antenna, and to sound the beeper.

The two motors are standard 1.5V to 3V model motors. They drive the rims of the wheels by simple friction contact with a short length of sleeving fitted tightly over their spindles. To provide the right force to drive the wheels without slipping, the batteries and motors are fitted to a section of the chassis which is folded over. Their combined weight is used to provide a steady force between the motor spindles and the tops of the wheels – see photographs.

Each of the antenna sensors is made from two pieces of bent springy wire. Anything that touches the longer wire bends it into contact with a surrounding loop of the other wire.

A cadmium sulphide light sensitive resistor (l.d.r.) gives the buggy its “eye”. The l.d.r. sensor is fitted with a short length of sleeving so that it is most sensitive to light from directly in front. Brighter light lowers the resistance of the sensor.

A piezo transducer, WD1, driven with a square wave from the PIC provides a “beeper” function.

CIRCUIT DESCRIPTION

The complete circuit diagram for the Brainibot Buggy is shown in Fig.1. All of the “intelligence” is provided by IC1 – the PIC12C508 microcontroller. This is one of the simplest PIC chips, but it is still capable of providing all the functions needed.

The commonly used 8-pin 12C508 and the bigger memory 12C509 PICs are more closely related to the earlier 16C5x parts and have some programming limitations compared to the more familiar PIC16F84. Despite this it was still possible to write the original program in a version of BASIC and compile it into a small enough hex file to fit comfortably.

Having an internal 4MHz clock, IC1 does not need external crystal or resistor/capacitor oscillator components. It

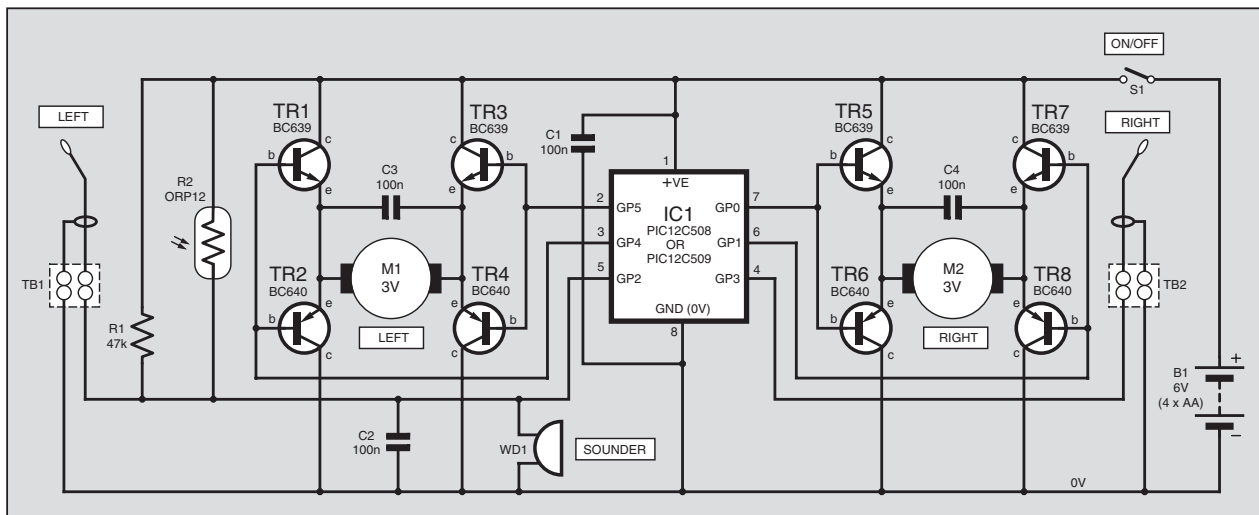

Fig. 1. Complete circuit diagram for the Brainibot Buggy.

also has an internal "power on reset" function (corresponding to the usual PIC MCLR pin) making effective use of the 8-pin package and leaving 6-pins available for inputs and outputs.

MOTOR DRIVE

The two motor drive circuits are identical. The Left motor M1 is driven from GP4 and GP5 of the PIC and the Right motor from GP0 and GP1. PIC output pins are relatively powerful, and can provide up to 25mA, but the small cheap motors used won't even move at that current and need 200mA to 300mA to do anything useful.

It is important to use reasonably efficient motors. The ones used in the prototype are specified as 46% efficiency at 3V and 110mA. Some cheap model motors are much less efficient and might not run very well. If there are problems with slow or unreliable running, make sure the motors are of good enough quality.

To provide the current needed to drive the motors, an emitter follower transistors configuration is used. Transistor TR1 is a *npn* device and is turned on when IC1 pin 3 is set *high*, and the *pnp* transistor TR2 is turned on when pin 3 is set *low*, so that the left hand connection of motor M1 is switched either via TR1 to the positive supply (+V) or via TR2 to the battery negative (0V). It is worth noting that TR1 and TR2 cannot be switched on at the same time – if they were, a high current would flow directly from +V to 0V. The right hand connection of M1 is switched in the same way via TR3 and TR4, from IC1 pin 2.

To motor drive M1 in the forward direction, IC1 pin 3 is set high and pin 2 is set low so that TR1 and TR4 are turned on. Current flows from the positive line (+V), via TR1, through the motor and TR4 to 0V. To reverse the motor, IC1 pin 3 is set low and pin 2 is set high so that current now flows from +V, via TR3, through the motor (in the opposite direction) and via TR2 to 0V.

If IC1 pin 3 and pin 4 are both low, transistors TR2 and TR4 are turned on and both motor connections are switched to 0V so that it cannot run. Similarly if pins 3 and 4 are high, both motor connections are switched to +V.

This arrangement of four transistors is called an H-bridge – because of the shape of the circuit diagram. It is possible to buy a single chip containing all of the 'H' bridge transistors, but they are usually designed for use at higher power levels and would cost much more than individual transistors for this simple application.

NOISE SUPPRESSION

Capacitor C3 is fitted directly across the motor connections to absorb the interference that is generated as the motor rotates and the brushes switch from section to section of the commutator. Without C1 there is a lot of electrical noise generated that can interfere with the program in IC1 and cause strange behaviour.

It is also a good idea to connect a wire from one of the motor terminals to the metal motor case. This provides improved interference suppression as the motor case acts as a screen. It is possible to solder to the motor case if it is first scraped with a knife, or a small area is cleaned with abrasive paper or a fine file.

The Right motor M2 is driven from pins 6 and 7 of IC1 and transistors TR5 to TR8. Capacitor C4 should be fitted in the same way as C3.

TOUCH SENSITIVE

Antenna sensors are fitted to the left and right front corners of the buggy. When they touch an obstruction the inner flexible wire bends and contacts its surrounding wire loop.

The loop surrounding the right hand antenna connects directly to input GP3 (pin 4) of the PIC. This pin has an internal resistor so that it is normally held up to +V and so is read by the program as logic '1'. When the antenna is touched it is connected to 0V and so it reads the input as a logic '0'.

The left antenna works in the same way, but input GP2 (pin 5) does not have an internal pull up resistor and the piezo sounder WD1, light-dependent resistor R2 and capacitor C2 are also connected to this pin. The sounder "looks" like a capacitor, so does not draw any current, i.d.r. R2 has a resistance between one kilohm in the light and one megohm in the dark, and is in parallel with R1 so that it has the effect of changing the pull-up resistor value.

Movement of the left antenna pulls pin 5 down to 0V, but the other components connected to this pin mean that the sensing has to be done in a special way – using GP2 first as an output and driving it high so that the piezo sounder and C2 are fully charged, and then switching the pin back to an input and reading the level. This is explained in the software section later.

The resistance of the l.d.r. R2 must be measured to determine the light level. This is done by a software routine that briefly shorts out capacitor C2 and then measures the time it takes to charge. More light reduces the value of R2 and thus provides a shorter charge time. It is not possible to measure the light level if the

COMPONENTS

Resistors

R1	47k 0.25W 5% carbon film	See SHOP TALK page
R2	ORP12 miniature light dependent resistor (l.d.r.)	

Capacitors

C1, C2	100n ceramic or plastic film, 5mm pitch
C3, C4	100n ceramic disc, long leads required

Semiconductors

TR1, TR3, TR5, TR7	BC639 <i>npn</i> silicon transistor (4 off)
TR2, TR4, TR6, TR8	BC640 <i>pn</i> p silicon transistor (4 off)
IC1	PIC12C508 or 509 microcontroller, pre-programmed (see text)

Miscellaneous

M1, M2	3V d.c. miniature motor (see text), 2 off
S1	s.p.s.t. miniature slide or toggle switch
B1	6V battery pack, 4 x AA with side-by-side holder and clips
WD1	piezoelectric sounder, low-profile

Printed circuit board available from the EPE PCB Service, code 383; 8-pin d.i.l. socket; 2-way min. screw terminal block (2 off); wheels, axles, sticky pads, self-adhesive motor clips (2 off) and chassis material (see text); sleeving for motor spindles and l.d.r. (see text); antenna wire (see text); connecting wire; solder etc.

Approx. Cost
Guidance Only

£20
excluding batts.

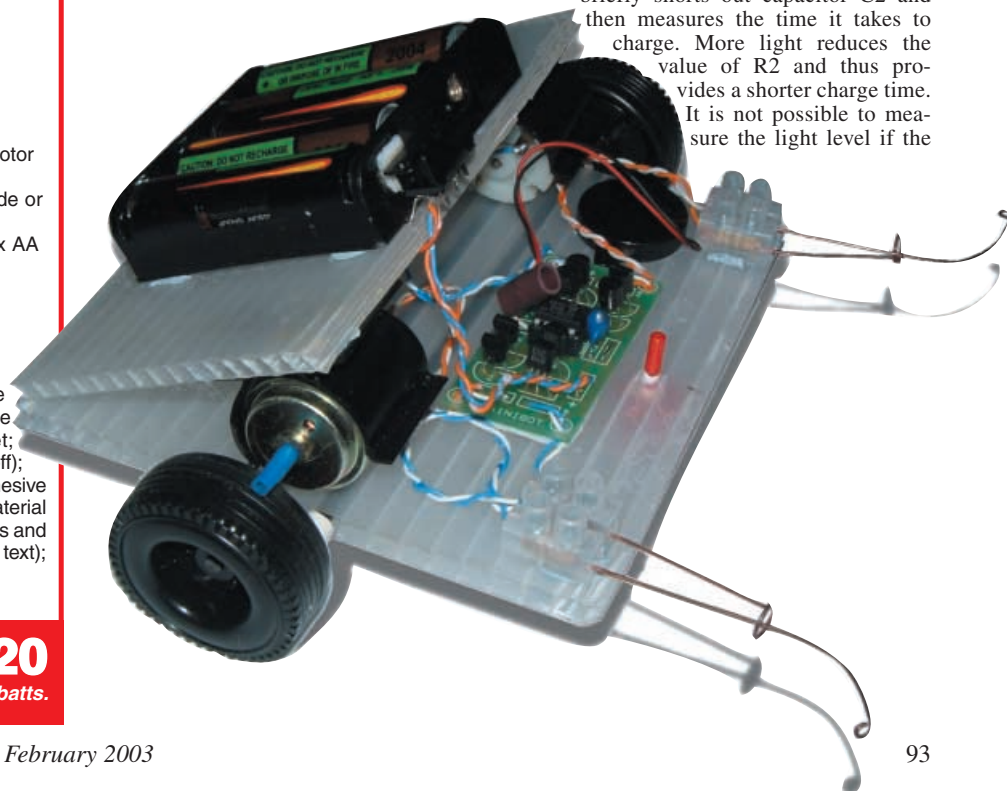

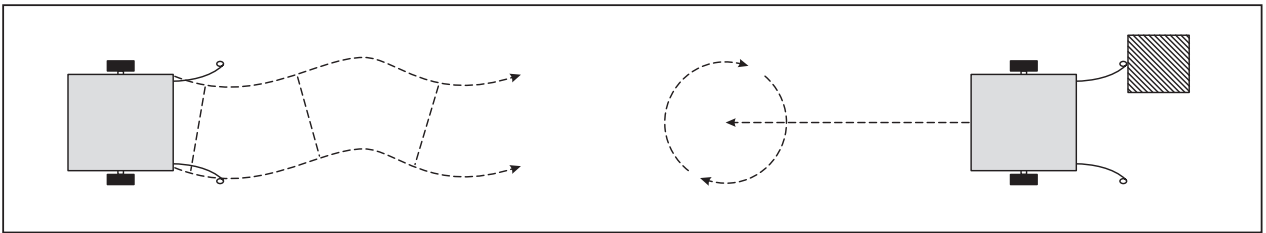

Fig.2. Demonstrating how Brainibot “waddles” forward whilst on the move and reverses and spins around when it meets an obstacle.

antenna is producing a short circuit, but this does not cause a conflict because the response to antennae is higher priority than the response to light.

Sounder WD1 is driven directly from the PIC by switching pin 5 alternately high and low. If there is a short circuit from the antenna the piezo sounder will be silent. All of the pins of IC1 are protected internally against short circuits, and so no harm is done if the antenna is shorted whilst there is a “beep”.

Capacitor C1 ensures a low impedance supply to IC1 and also makes sure that there are no noise spikes on the supply, especially when the motors are running.

BEHAVIOUR

The buggy is programmed to seek brighter light and avoid obstacles. It begins by moving forward, turning to the left and right, at each turn it measures the light level. In this way a single light sensor can be used to determine the direction of the light.

If there is a difference between the light levels, it “chirps” and turns away from the darker direction. If it has not found any difference in light levels it continues to “waddle” forward. All the time a record is kept of the brightest light level. If there is no increase after a time it assumes that it is stuck in a corner and tries to get away by backing up and turning.

If an antenna is touched, the buggy responds by backing up and spinning away from the touched side – see Fig.2.

CONSTRUCTION

Begin construction by fitting the motor suppression capacitors C3 and C4. These should go directly across the motor terminals with their leads cut as short as possible – they can be fitted either way round. Fit a short wire from one of the motor terminals to the motor casing – see Fig.3 – this has been found to reduce radiated TV and radio interference.

The plating on the motor casing does not always solder easily, and so it is necessary to scrape or file a small area to get a good joint. You *MUST* take care not to let any filings fall inside the motor where they could stick to the magnets and jam the rotor.

CIRCUIT BOARD

It is now time to assemble the components on the small printed circuit board (p.c.b.) This board is available from the *EPE PCB Service*, code 383. The p.c.b. topside component layout and full-size underside copper foil master pattern is shown in Fig.4.

Identify the notch at the end of the socket for IC1 – it will help to make sure the PIC is plugged in the right way round later.

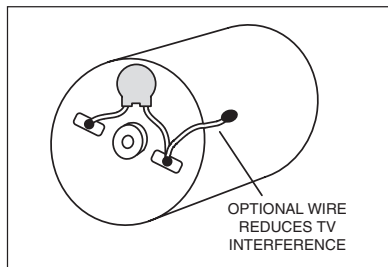

Fig.3. Connecting a capacitor (C3 or C4) directly across the motor terminals and a wire to the casing to reduce interference (see photo).



Take care to put the transistors in the right places – a little care to eliminate simple mistakes here will save a lot of time fault finding later. Capacitors C1 and C2 can fit either way round. Resistor R1 should be fitted so that it stands upright. Fit a bare wire link in the position marked LK1. The light-dependent resistor (l.d.r.) has to bend forward over IC1, as shown in Fig.5, so that it “looks” towards the front. Fit a short

piece of sleeving, stripped from one of the connecting wires, over the l.d.r. lead closest to the edge of the board, and fit a 10mm length of tubing over the main body as shown.

The light sensor works better if it is angled upwards 30 degrees or so as shown. The l.d.r. tube used in the prototype, was a piece of the outer insulation from a piece of TV coaxial cable.

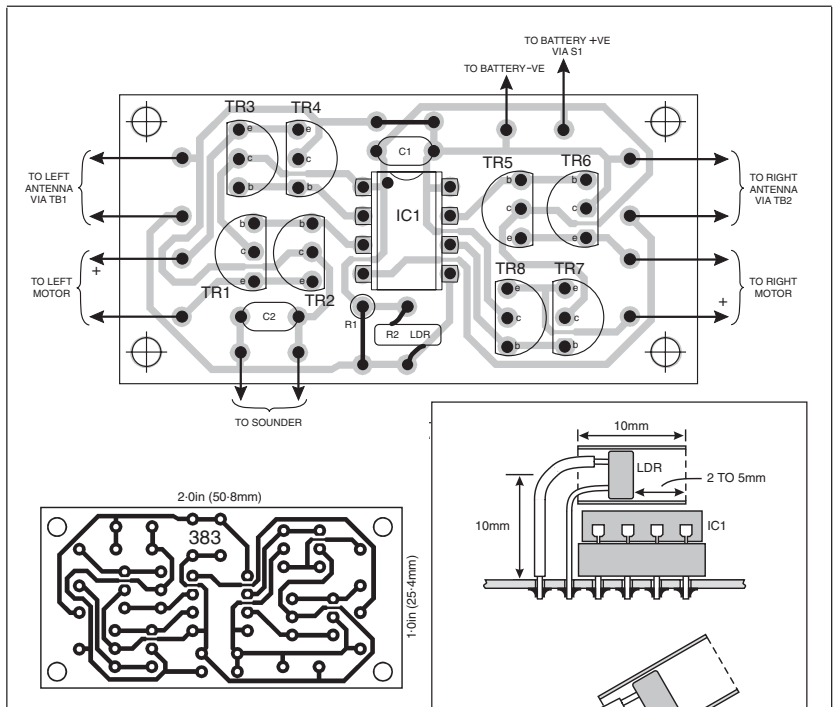

Fig.4. Printed circuit board component layout (enlarged), lead-off wires and full-size copper foil master.

Fig.5 (right). Method of mounting and shielding the l.d.r. light sensor.

When the board is fully assembled, check it carefully for dry joints, solder bridges and correctly placed components. Do not fit IC1 until the board has been tested – see later.

WIRING

There are 12 wire connections to the printed circuit board. The sounder WD1 is fitted with two wires that can be connected either way round to the position marked SND on the board. The other 10 wires should all be cut to approximately 8cm long and fitted to the positions marked for the motors, antennae and battery. Use red and black for the battery connections to help make sure the polarity is right.

To fit each wire, strip about 6mm from the end, pass the wire into the board from the component side and solder it on the copper track side. The wires can be looped through the board corner fixing holes so that they can be moved around without stressing the joints too much.

The motor wires should be connected to the motors after the mechanical chassis assembly has been completed. The motors are embossed with + and – signs, make sure the leads are connected the right way round, otherwise the motors will run backwards – with confusing results.

The slide switch S1 can be fitted directly to the battery holder terminals or can be fitted into the wiring and mounted on the chassis. Check the battery holder to be sure which are the positive and negative terminals and make sure they match the connections marked on the p.c.b.

CHASSIS ASSEMBLY

The mechanical parts for the buggy have been kept as simple as possible, but with a little care and some adjustments the assembly works reliably. More robust methods of assembly suggest themselves, and the electronics controller can be used with many different types of motor but the supply **must not** exceed 6V, and performance will be limited if it falls below 4V.

Begin the chassis assembly by cutting a piece of corrugated plastic card to the dimensions shown in Fig.6. Two cuts must be made across the card to just one side so that it can be folded over. The two “bumpers” are fitted by pushing them into tight fitting holes that can be made with a

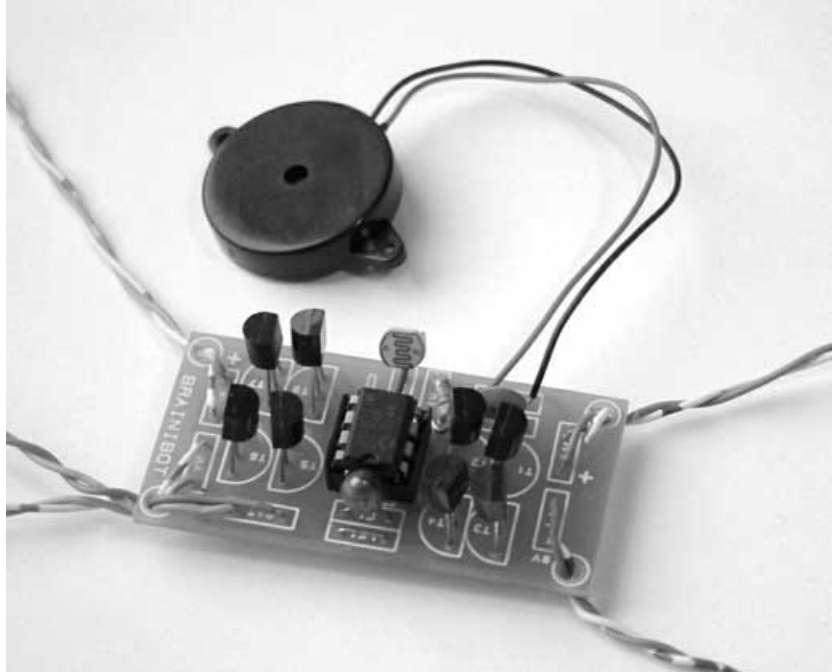

Components mounted on the completed circuit board. Note the connecting leads threaded through the four corner holes to help secure the wires.

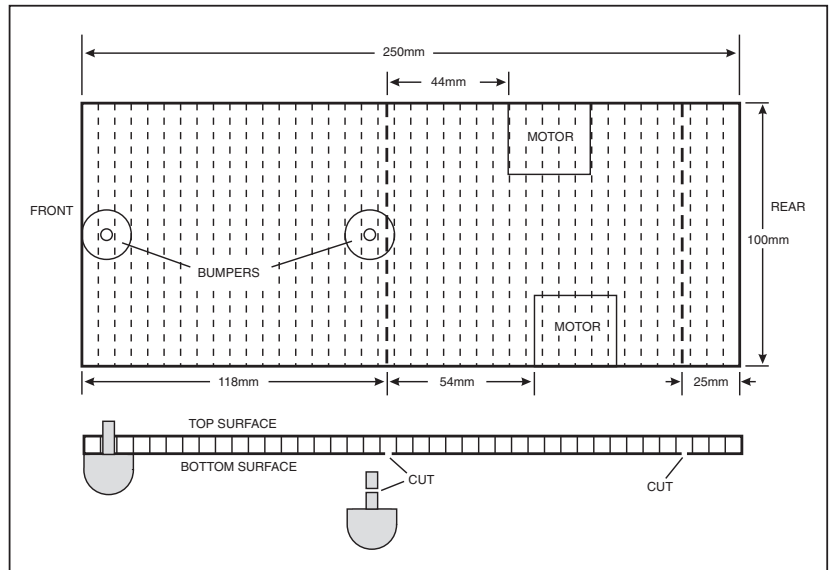
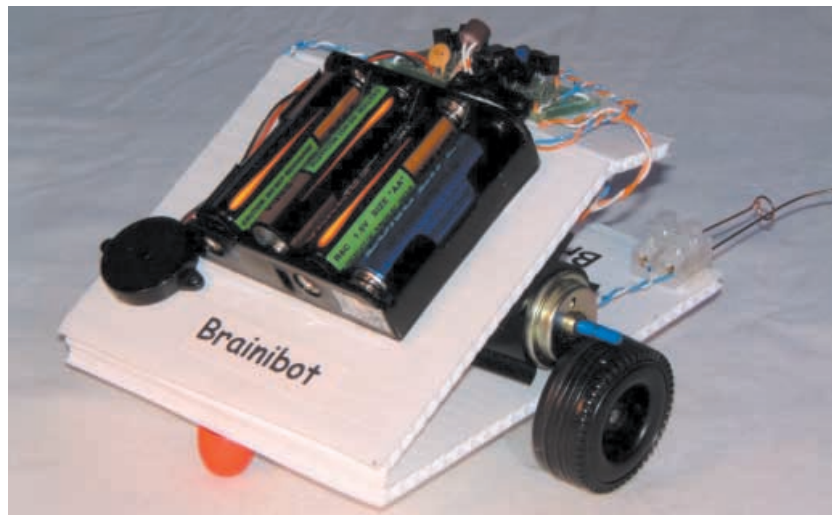

Fig.6. Chassis assembly dimensions, cutting/folding details and general displacement of the motors.



Close-up of the light-dependent resistor (l.d.r.) mounting.



Prototype buggy showing the “chassis” folds and the mounting of the battery pack.



Art pegs used to form the bumpers.

sharp pencil or knitting needle. The peg on the rear “bumper” should be cut short so that it doesn’t get in the way of the fold. The bumpers can be made from anything smooth and round — the ones pictured are “Art Pegs” used with children’s perforated craft boards.

Two axles 122mm long are made from 4mm diameter hard plastic and should each be fitted with 4mm long pieces of thick sleeving to act as bushes and prevent the wheels moving too close to the edge of the chassis. Diagram Fig.7 shows this assembly. Pieces of the outer insulation cut from 3-core 3A mains cable were found to be ideal.

Fit one wheel to each axle; thread the axles through the chassis in the positions shown and fit a 6mm piece of bushing to retain each in position. Check that the wheels can rotate freely. Some of the hard plastic material suitable for axles contains glass fibre and should be cut carefully where the dust can be removed effectively.

The motor spindles should each be fitted with a piece of thin p.v.c. sleeving to improve the friction contact with the wheels. Rubber sleeving has been tried for this job but proved to be much less efficient than the harder p.v.c.

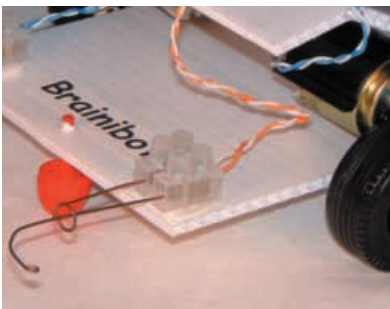

An antenna mounted in terminal block.

Plastic clips are used to hold the motors and provide a flat base to fit to the chassis with double-sided sticky pads. Take care to get the position right as they are not easily removed. It is helpful to try first using Blu-tak or similar to test the assembly before making more permanent fixings. The wheel axles can be moved backwards or forwards one slot if necessary to get better contact with the motor spindles.

ANTENNAE

The antennae are made by bending pieces of springy wire. Copper or mild steel wires are not springy enough, and the

prototype used 0.8mm copper covered welding wire. Each antenna consists of a long sensing arm, and a surrounding contact ring. This arrangement is shown in Fig.7. Do not ruin good tools by trying to cut springy wire – it is harder than component leads and will dent the edges of all but the toughest cutters. The best way to cut it is with fine grinding wheel on a mini drill. Handle the wire with care and use eye protection in case it snaps.

Bend the wire to the shapes illustrated in Fig.7 and fit the pieces into two-way screw terminal blocks. Pass the wire right through so that each piece is held by both terminal screws. Fit the terminal blocks to the front corners of the chassis as illustrated using



Miniature motors and plastic clips.

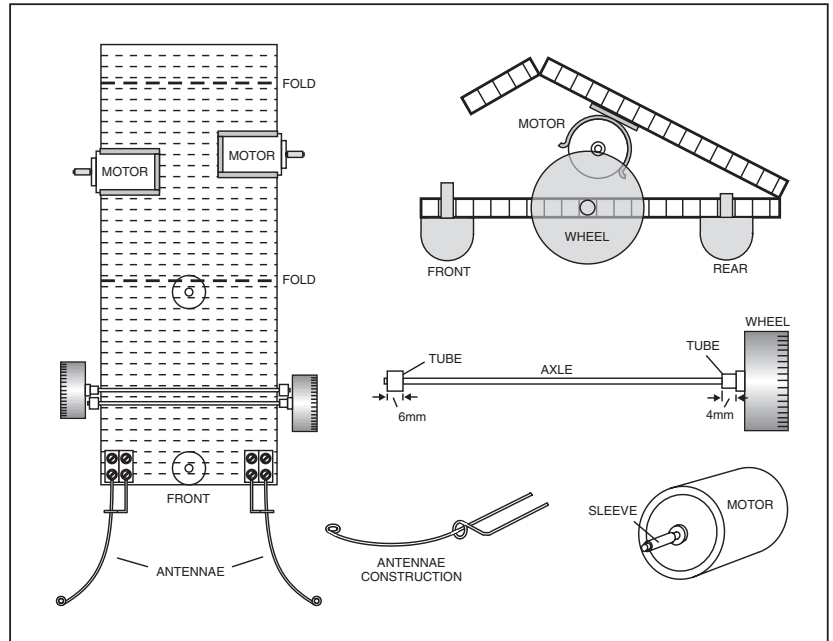

Fig.7. Mounting the components on the chassis assembly. The weight of the motors and battery pack ensure the motor spindles engage the wheels.

double sided pads, and check that each antenna wire passes through the center of the ring *without* making contact.

FINAL ASSEMBLY

Mount the battery holder onto the folded over section of the chassis using double-sided sticky pads, and make sure that switch S1 connections are made correctly. The sounder WD1 can be placed anywhere convenient on the chassis.

Fitting the control board and making the connections to the motors and antennae completes the final assembly. Cut the connecting wires short enough to make a tidy layout but leave enough slack to make adjustments to the motor positions if necessary. It should be possible to slacken the rear screws of the antenna terminal blocks to accept the connecting wires without upsetting the antenna positioning. Make sure the left and right connections are not swapped over.

The control board could be mounted on the folded over roof, but the l.d.r. must be repositioned to be sure it looks in the correct direction.

TESTING

Do not fit IC1 until the first stages of testing are completed.



Wheel and axle parts.

Make sure power switch S1 is in the Off position and fit the batteries. Lift the buggy off the ground and switch on. There should be no movement and nothing should get hot! If a multimeter is available, check that pin 1 of the socket for IC1 is at +6V and that pin 8 is at 0V.

Switch off and plug in a programmed PIC into its socket, with the notched end towards capacitor C1 on the board, and make sure that the l.d.r. is bent so that it “looks” forwards and upwards at about 30 degrees.

Hold the buggy off the ground and switch on. The motors should begin to turn

and when placed on the ground it should move forward whilst “waddling” left and right looking for light. If it sees a difference it should “chirp” and turn away from the darker direction.

If the buggy always moves backwards, it is likely that the motors are wired in reverse, or have been fitted on the wrong sides. It is also possible that one or both of the antennae are misaligned and short circuited. If one motor is always on and the other is always off, or a motor only runs in one direction, it is very likely that there is a fault on the driver board. Check the transistor types, and their soldering in case there are dry joints or solder bridges.

The chirp sound is produced when light intensity changes. If the light is too bright or too dark the intensity will not appear to vary, and the chirp will not sound. Check that the tube is correctly positioned over the l.d.r. The tube needs to be long enough to make the response directional, but not so long that it makes the l.d.r. too dark. If it does not seem to respond, check its connections to the board, and that C2, R1, and the sounder are correctly connected.

If the light sensing is working, the buggy will run until it does not see a light increase for several seconds. It will then reverse and spin on its axis before resetting the bright light memory, and starting a new search.

OBSTACLE COURSE

When an antenna touches something and short circuits to the “loop” the buggy backs away and spins away from the obstruction. If it appears to spin towards the obstruction, it is possible that the left and right antenna connections have been swapped over. If one of the antennae is permanently shorting to the ring, or there is a short circuit on the p.c.b., the buggy will continually back up and turn.

All of the motor functions can be checked by removing the PIC and using a pair of 100 ohm resistors to connect pins 2, 3, 6 and 7 of the socket to +V (pin1) or 0V (pin 8). Refer to the circuit diagram and remember that one pin must be high and the other must be low for the motors to be powered.

It is possible that just one motor terminal is being driven correctly and the other is not. Using a multimeter in combination with the resistors will allow any faults of this type to be traced with a little patience and care.

SOFTWARE

A brief description of the software functions would be as follows:

A main loop runs all the time:

Start

Initialise Variables

Main Loop

 HeadToLight

 GettingLighter

goto Main Loop

The HeadToLight routine finds and drives towards the brightest light.

GettingLighter gets out of dead-ends and makes the buggy seem about 10 times more intelligent.

HeadToLight

The buggy waddles alternately to the left or right

If it's waddling to the left:

go forward-left for about a second (while checking the antennae)

turn the motors off

short delay to let the interference

from the motors die away

measure the light

if the light is less than last time after a waddle then

 make a noise

 go forward-right for about a second

The next time HeadToLight runs, “left” and “right” will have been swapped.

Overall, this means that the robot turns toward light.

GettingLighter

GettingLighter measures the light level and keeps a record – in “BestLight” – of the brightest level seen so far. If BestLight hasn't increased in the last 20 calls to GettingLighter then the buggy assumes it's stuck in a corner and tries to get away.

It backs up (ignoring the antennae), makes a noise, and spins on its axis (checking the antennae) looking for the brightest direction. It spins in the direction of the last waddle. It then resets BestLight to zero.

Motor Drive

The motor control routines provide forward, backward, left and right functions.

The motors are not just switched on, but pulsed with a 50/50 mark space ratio. This saves battery power, and reduces the speed to a suitable level for control. The friction drive is quite efficient and powering the motors just half of the time is enough. The pulsing is done at high frequency so that the motors run smoothly and without any extra noise.

While the motors are running, the antenna inputs are checked. If either has touched then the program abandons whatever else it was doing and jumps to deal with the antenna touch. Before restarting the main loop.

Antenna Touch

Pin 5 of the PIC (IC1) handles the l.d.r., the sounder and an antenna.

To check whether the antenna is touched, the following routine is used. The first two instructions make sure that C2 and the sounder capacitance are charged, and so do not give a false indication of a shorted antenna.

set I/O pin 5 to output

set I/O pin 5 high

wait a few milliseconds

set I/O pin 5 to input

read I/O pin 5

if I/O pin 5 is low then the Left antenna is touched

(It is worth noting that having a capacitor on the pin and charging it before changing the pin back to an input and reading it allows a switch to be connected to an I/O pin and read effectively without having a pull up resistor.) The technique can be taken even further and will work without fitting a capacitor – relying completely on stray capacitance.

Reading the right antenna is simple – if I/O pin 4 is low then the antenna is touched.

If an antenna is touched, the buggy backs up and spins away from that side. In this situation it ignores the antennae while the motors run.

Measure Light

The light is measured by

set I/O pin 5 to output

set I/O pin 5 to low

wait a while to discharge C2

set I/O pin 5 to input

count how long it takes for I/O pin 5 to read '1'

The “count” is longer in lower light as l.d.r. R2 has a higher resistance. If the light is very low then R1 in parallel with l.d.r. R2 helps to charge capacitor C2 and has the effect of improving the low light performance.

The response is non-linear so the counting is done more slowly as the count gets higher – this allows the count to give a useful reading over a wider brightness range.

Sound

The piezo sounder WD1 does not have a built in oscillator and so acts as a simple loudspeaker (with a terrible frequency response!). It is driven by setting I/O pin 5 to output and switching it rapidly between '1' and '0'. By altering the switching speed and mark-space ratio a limited range of different sounds can be produced. When the sound is finished, the I/O pin is returned to being an input.

RESOURCES

The software is available for free download from the *EPE* ftp site. This is most easily accessed via the main page of the *EPE* web site at www.epemag.wimborne.co.uk. At the top is a click-link saying **FTP site (downloads)**, click it then click on **PUB** and then on **PICS**, in which screen you will find the Brainibot folder.

The software can also be obtained on a 3.5-inch disk (Disk 6) from the Editorial office. There is a nominal handling charge to cover admin costs. Details are given on the *EPE PCB Service* page. This month's *Shoptalk* gives details about obtaining pre-programmed PICs and also complete Brainibot Buggy kits, including hardware.

FINALLY

This project shows just what can be done with some very simple hardware and one of the smallest PIC microcontrollers. Hopefully it will inspire experimentation with both hardware and software, and lead to more advanced projects. □

Something very suspicious here!

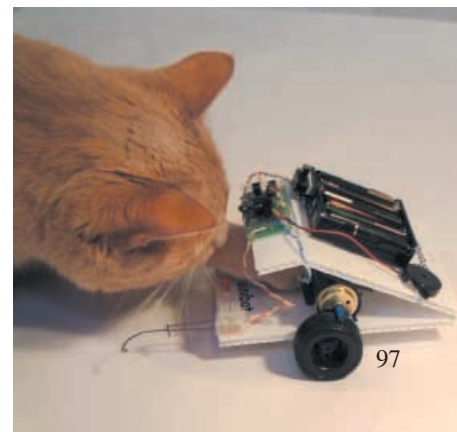

New Technology Update

Development of carbon nano-tubes is likely to have a serious impact on semiconductor technology. Ian Poole reports.

NANO-TECHNOLOGY is one of the major new developments to hit the scientific community in the last ten years. The applications of the new technology are widespread, affecting areas from strengthening materials to cosmetics, and, of course, they have many applications in electronics. Interestingly, it is the cosmetics manufacturers who have taken out the largest number of nano-technology patents!

The technology focuses on manipulating materials at the nano-scale. As a nanometre spans only three or four atoms, this effectively means at the atomic level. Richard Feynman first postulated the idea at a lecture that he gave in 1959. His overall concept was that it would be possible to manipulate matter at an atomic level, rearranging electrons, protons and neutrons to produce whatever was required. However, it has taken many years to be able to start to realise the dream.

Origins

It was in 1974 that the term nano-technology was first used. It appeared in a paper presented by Professor Norio Taniguchi of the Tokyo Science University. The first major step along the road to practical realisation of the technology occurred in 1982 when the scanning tunnelling microscope (STM) was invented. This machine enabled individual atoms to be manipulated. In the same year the same research group devised another device called the atomic force microscope (AFM). These two devices enabled the birth of nano-technology to take place.

In view of the revolutionary nature of the new technology, it has taken many years to develop it to a stage where it is beginning to be used. Now it is possible to use it in many ways.

Nano-tubes

Currently some of the most promising aspects of new technology are associated with the use of carbon nano-tubes, and these have been described previously in this column. These tubes have a wall of carbon atoms one atom thick and they can be used to provide very strong, but light materials.

The tubes themselves are very much stronger than steel, and yet much lighter. In view of this there are many possible applications, and the automotive industry is looking very closely at them as they will be able to provide much lighter, yet stronger materials for vehicles.

For the electronics industry, these tubes are of great interest because they are able to carry very high levels of current whilst exhibiting very low levels of resistance at

room temperature. As they can be fabricated with sizes suitable for integrated circuits this makes them ideal for use as interconnections within integrated circuits. This enables i.c. performance to be considerably improved.

Transistors have also been fabricated using nano-technology. Here the nano-tubes form the channel within the transistor, enabling very low levels of *on* resistance to be achieved, along with very fast transition times.

In one development IBM have demonstrated a transistor using just a single carbon nano-tube. Whilst this is only a laboratory demonstration at the moment it proves that single carbon nano-tubes can be used as the basis for transistors. If this could then be integrated into a large integrated circuit, then terabit memories could be made.

Several research organisations have developed laboratory nano-tube based devices. These are not yet in a state where they can be manufactured, but this development has started. Timescales of five years and more are being mentioned in the industry and even now several chip manufacturers are looking very seriously at manufacturing them.

IBM is obviously a contender but Motorola has also started work to investigate them. They have started characterising nano-tubes for use in sensors and they are also carrying out work in other areas.

Current uses

Whilst integrated circuits using nano-tubes are not yet available, there are some other devices that are currently on the market that use them. A number of business agreements are being set up to licence manufacturers to use some processes.

In one of these DuPont has an agreement to use some of this technology in their flat panel displays. Here they use nano-technology as a thick film emitter. This gives significant improvements, making the displays lighter, brighter, smaller and more efficient.

New Developments

Whilst commercialisation of nano-technology is moving forward, new developments are also taking place at the research institutions. In one of these, undertaken at the University of Surrey, researchers have grown carbon nano-tubes at room temperature and this could have a significant impact on the development of large flat panel displays as well as many other devices.

Previous methods of creating carbon nano-tubes have required the use of

temperatures of at least 700°C. This is well in excess of the temperatures that plastics can withstand and as a result this considerably limits the ways in which nano-tubes can be used. Temperatures of 700°C can also damage many semiconductor substrates, making processing difficult and costly. The new process should open the door for many more nano-tube applications.

The new process involves coating the substrate into which the nano-tubes are to be grown with a nickel catalyst. It is then placed into an r.f. plasma of methane or methane-hydrogen. The substrate in the plasma then has a sheath around it and it is not heated. However, it is found that some of the nickel particles protrude through the sheath and they are heated to a sufficiently high temperature.

Carbon atoms are then diffused into the nickel using r.f. plasma enhanced chemical vapour deposition. Eventually the nickel becomes saturated with carbon, and the atoms are forced out and form a carbon nano-tube. Once the basic nano-tube has formed, the process continues with the nickel absorbing carbon from the plasma and depositing it onto the end of the nano-tube, and in this way its length steadily grows.

The basic process that is used to grow the nano-tubes is a standard industrial process. It has been used to deposit materials onto large surfaces. As a result it is expected that it could be used to grow nano-tubes for large displays. This would give nano-tube displays a distinct edge over other technologies as they could be made to cover large surfaces. In addition to this they provide a high level of light output.

Summary

Nano-technology is growing in its importance. Over the coming months and years it is expected to impact not only the electronics industry but many others in a very significant way. Atomic scale integration combined with the ability to cover much larger surfaces means that the opportunities for using the technology are enormous.

Not only are some of the major research institutes investing large amounts of effort into the development of nano-technology, but so are the semiconductor manufacturers. This means that this technology could be the next revolution to hit the electronics industry. As some products are already available, we may not have too long to wait to see many more arrive.

Further information about radio and electronics technology, new and old can be found at www.radio-electronics.com.

LISTEN WITH MURDOCH

A new system magically makes all Sky+ boxes able to record radio by setting time and station from a menu.

Barry Fox reports

RUPERT Murdoch's grip on broadcasting is tightening. The Sky+ hard disk recorder/receivers which BSkyB sells to record digital satellite TV can now do what radio listeners have always wanted; record radio programmes while owners are out, automatically switch channels, and go on recording for days on end without needing a new tape.

There are however a couple of little snags. The system only works in the UK or Ireland where Sky rebroadcasts 50 national, local and ethnic digital terrestrial radio stations by satellite. The Sky+ combined recorder and receiver needs a satellite dish, costs several hundred pounds to install and only works while the owner pays £10 a month to feed it Sky's proprietary programme schedules.

The 40GB hard disk normally holds around 40 hours of digital TV.

Cross Purposes

Some of the 30,000 people who bought Sky+ over the last year got cross when they found they could listen to radio but not record it. Sky said it was because only TV programmes have the digital time codes needed to set the recording timer.

Now, with minimal publicity, Sky has transmitted new control software over the air which magically makes all Sky+ boxes able to record radio by setting time and station from a menu.

The radio recording takes only the bit space it needs, 192kbps or less, instead of the 2Mbps or more needed for TV. So Sky+ can record at least 400 hours of digital radio. The rival hard disk system, from TiVo, can be fooled into recording radio instead of TV, but the sound soaks up as much bit space as TV. It too costs £10 a month to use.

Pace makes the Sky+ boxes and this winter launches a digital terrestrial hard disk recorder which will be able to record whatever digital radio channels the TV broadcasters slot into their TV transmissions. The Pace box will work like Sky+, recording only the bandwidth needed for radio. No subscription of any kind will be needed to use the Pace box.

SHINE A LIGHT

ADVERTISERS – Don't hide your new products or services – highlight them **FREE** via our News pages!

TROLLEY WATCH

Barry Fox

SUPERMARKETS, tired of rescuing their trolleys from local canals, estates and children's playgrounds, are now using a system which automatically brakes at least one of the wheels if the trolley is taken outside the supermarket car park. The brake then releases as the trolley is carried back. Full details of the system are available from US patent 6 353 388, filed two years ago by Gatekeeper Systems of Irvine, California. It can also be used to protect industrial forklift trucks and even children's toys.

The metal body of the shopping cart acts as an aerial to pick up a pulse modulated magnetic field generated by hidden cables buried or slung around the car park perimeter. One of the front wheels is hollowed out to hold a battery, receiver, rotation sensor and a motor which turns clockwise or anti-clockwise to move a nylon brake pad towards or away from the inner surface of a wheel drum.

The motor is switched by a flip-flop, triggered by a change in the magnetic field. If the rotation sensor detects that the wheel is moving when the magnetic signal disappears, this means the trolley is being moved past the perimeter and outside the park. So the motor turns to apply the brake. If the sensor detects that the wheel is stationary when the magnetic signal reappears, this signals that the trolley has been carried back into the park, past the perimeter. So the motor turns in the opposite direction to release the brake.

SPICED UP CIRCUITS



RD Research has announced the release of the new B² Spice V4.2 with circuit animations. This new software allows professional and amateur electronics designers to create and model complex circuit designs on a PC. The software shows wires changing shape to reflect current, voltages and parts changing colour to reflect heat dissipation.

Relative voltages are colour-coded to magnitude and arrows display the actual current paths as they flow within the circuit. Circuits can be animated with respect to d.c. stepping, frequency sweep, etc. Circuit animation can give both general and specific insight into the behaviour of the circuit as the simulation is running.

Furthermore, with this new version, users of Eagle PCB can now transfer their circuit schematics to B² Spice and run simulations quickly and easily.

For more information contact RD Research, Dept EPE, Research House, Norwich Road, Eastgate, Norwich NR10 4HA. Tel: 01603 872331. Fax: 01603 879010.

Email: rd.research@paston.co.uk.
Web: www.looking.co.uk.

GREENWELD'S EMAILS

AS we go to press, the latest of Greenweld's weekly emails has just dropped in. By the time you read this, of course, more will have come in, but to give you a taste of what to expect this latest one has an introductory price offer on a new bench power supply range; special offer on 1500W inverters; latest surplus items; computer links; Customer Corner – Newsgroups; catalogue requests; bulk deals, auctions; contact details.

The latter can be summarised as: Greenweld Ltd, Dept EPE, Unit 14 Horndon Business Park, West Horndon, Brentwood, Essex CM13 3XD.

Tel: 01277 811042. Fax: 01277 812419.

Email: bargains@greenweld.co.uk.

Web: www.greenweld.co.uk.

Get yourselves on Greenweld's emailing list – don't miss out on the exciting bargains that they regularly have on offer!

BAEC ENDS

WE are sorry to learn that the British Amateur Electronics Club (BAEC) has ceased. Our records do not show for how many years the BAEC has been a forum through which like-minded electronics enthusiasts have been able to share their enjoyment of their hobby, and exchange ideas and circuits through the Club's Newsletter. To this commentator's knowledge, the period must run to at least three if not four decades.

The announcement was sent to us by Otto Schiffer, BAEC's Treasurer. In his letter, Otto first thanked us for the support that we have always given to the Club, including the donation of free advertising space in *EPE*. We have indeed been very pleased to support a Club that we were convinced was well worth encouraging.

Otto went on to say that in the opinion of the BAEC committee, the Club had reached the end of its useful life. He comments that "the number of members has steadily declined over the years . . . making production of the Newsletter extremely difficult as there are fewer articles being contributed." The current Editor, G. Burton, has been unable to publish any Newsletters for 2002. Consequently it was decided that the BAEC should cease to exist at the end of 2002. So ends another era – very sad.

ELECTRONICS QUALIFICATION

EMTA Awards Ltd (EAL) has launched an electronics qualification designed to plug a gap in the market. The Foundation Certificate in Electronics is a Vocationally Related Qualification (VRQ) and is suitable for anyone aiming for a career as an electronic repair or installation technician or a post in retail electronics.

It is open to people aged 16 and over who are new to the electronics industry, those wishing to learn new skills and those preparing to enter the industry.

The qualification is available in colleges and through training providers and represents 240 hours of study. It comprises four mandatory units: Electrical Circuits; Introductory Electronics; Using Components and Tools; Electronic Systems and Installation.

The Certificate can be used to underpin some of the knowledge and understanding aspects of the Level 1 NVQ in Performing Engineering Operations. EAL is a nationally-recognised major awarding body.

A guidance pack and syllabus for centres wishing to deliver the Foundation Certificate in Electronics is available from EAL Customer Services, tel: 01923 652400.

Email: customer-care@emta.org.uk. Web: www.eal.org.uk.

RALLY ROUND

WYTHALL Radio Club are holding their 18th Annual Radio and Computer Rally on Sunday 9 March at Wythall Park, Silver Street, Wythall, near Birmingham, on the A435, just two miles from junction three of the M42.

Doors open from 10am to 4pm and admission is only £1.50. There will be plenty of traders in the three halls and a large marquee. Bar and refreshment facilities are on site, there is a Bring and Buy stand, and a unique *free* Park and Ride for easy comfortable parking. Everyone is welcome!

For Licensed radio hams talk-in is available on S22. For other information contact Rally Organiser, Martin G8VXX on 0121 474 2077, evenings. Fax: 0121 742 3471, working hours. Email: enquiries@wrcrally.co.uk.

NEW CD STANDARD

Barry Fox

PHILIPS has now agreed to a standard for High Capacity CD Recording; 12cm discs will play for 98.5 minutes, 8cm discs for roughly 30 minutes. The track pitch will be slightly tightened on the assumption that modern players will be able to cope. But some may not and Philips warns that although playable on the majority of CD drives, "High Capacity Recordable is not fully compliant with the Red Book (so) to avoid any misunderstanding . . . use of a CD logo is not allowed on this disc." The new discs will be used only as blank media because these are usually played back on the drives that recorded them. If HC music discs were released there would inevitably be many older players that could not cope.

In Japan there are moves to cut pressing costs with half thickness DVDs. But these also may not play on existing players, so it is unlikely the DVD Forum will give official permission.

YOU WON'T GET YOUR FINGERS BURNT

It may surprise you but buying an Antex soldering iron costs less than you think in the long run. British made to exacting standards, they last significantly longer than imported brands. And with a wide range of thermally balanced soldering irons, you can pick up a "fixed temperature" or "in-handle" temperature model that will suit your needs perfectly.

None of which will burn a hole in your pocket.

If your hobby demands the best iron for the job but you don't want to get your fingers burnt by the cost, visit our website or your electronics retailer for the coolest models around.

Pick up an

ANTEX
Not just any old iron.



www.antex.co.uk

2 Westbridge Industrial Estate Tavistock
Devon PL19 8DE Tel 01822 613565

CIRCUIT SURGERY

ALAN WINSTANLEY
and IAN BELL

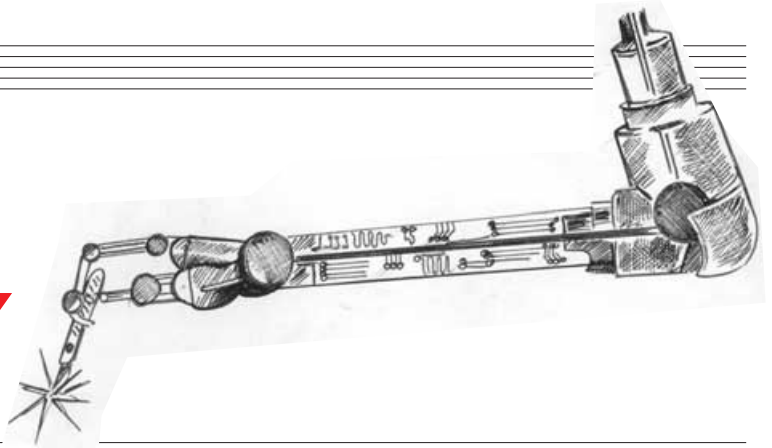

We continue with our item on using MOSFETs and also some differences between switching speeds of a.c. motors.

Power MOSFET Drive Circuits

Last month we responded to an email from *Dave Lerner* asking about the large variety and forms of construction of power MOSFETs. As we explained, this wide range of devices results in a variety of trade names for them, which can seem bewildering at first.

The solution is to decide what type of device you need – for instance, high voltage, high current, high switching efficiency? Then to look for devices optimised for that use with the appropriate specs in terms of power dissipation, on resistance, maximum drain current, drain-source voltage, etc. You usually don't have to worry too much about the exact construction or name though.

This month we look at basic power MOSFET driver circuits. This is a large subject area, so we shall provide an overview of the various forms of driver, and point out some of the things you need to think about when designing these circuits.

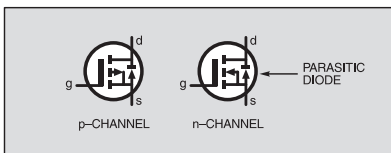

Fig.1. Power MOSFET symbols showing parasitic diode.

In Fig.1 we show the full power MOSFET symbol that includes the *parasitic diode* between drain (d) and source (s), which is an intrinsic part of the MOSFET's structure. This diode is quite often not included in schematics, the basic MOSFET symbol being used instead.

The intrinsic diode can be used as a *freewheeling diode* when switching inductive loads – a freewheeling diode conducts the current produced by an inductor from its stored energy when an applied voltage is removed, preventing excessive voltages (back e.m.f.) from occurring in the circuit. However, in applications requiring high frequency switching the intrinsic diode does not have high enough performance

and an external diode must be used. Take care when reading power MOSFET schematics to check whether an external or internal diode is depicted.

In addition to possible freewheeling diodes, other components may be required in a *snubber* circuit. The function of a snubber is to protect the MOSFET from excessive voltages, currents, or rates of change of voltage or current that may otherwise damage the device.

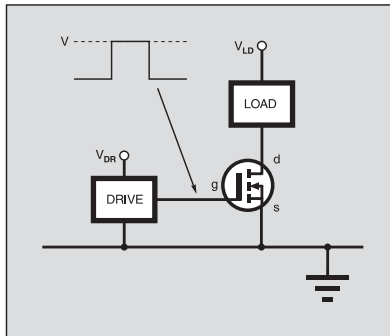

Fig.2. Low-side drive using n-channel MOSFET. V_{DR} is the drive voltage and V_{LD} is the load voltage, which may be on a separate rail.

Highs and Lows

There are a number of different configurations in which power MOSFETs are used. With a single transistor we can employ *n-channel* or *p-channel* devices, and we can use *low-side* switching, where the MOSFET is grounded, or *high-side* switching where the MOSFET is connected to the load power supply voltage. *N-channel* devices are often preferred because the inherently higher conductivity of *n-type* silicon leads to higher performance devices. High-side switching is, however, often easier with *p-channel* devices.

An *n-channel* low-side switching arrangement is shown in Fig.2. The drive circuit has to switch the gate between 0V (off) and V_G (on). The power supply voltage for the driver (V_{DR}) will usually be greater than or equal to V_G , but may be much less than the load power supply voltage (V_{LD}).

The value of V_G required to fully turn on the MOSFET is typically 10V to 15V, but devices designed to switch at lower voltages are available. A TTL-compatible MOSFET is intended to ensure reliable operation when its gate is driven by TTL logic levels, even though the usual TTL tolerances will exist.

If we require that the load is grounded, then we need a *high-side switch* instead. Here a *p-channel* device is used as a high-side switch, see Fig.3. Note that the gate

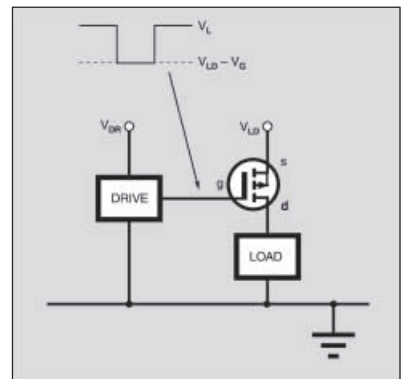

Fig.3. High-side drive using p-channel MOSFET. V_G is the MOSFET gate voltage.

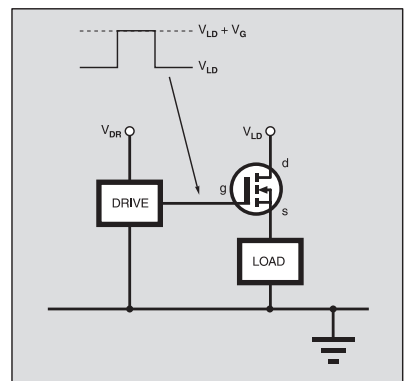

Fig.4. High-side drive using n-channel MOSFET.

(g) voltage is switched from V_{LD} (off) to $V_{LD}-V_G$ (on). Another high-side switch is shown in Fig.4, in this case using an *n*-channel MOSFET and therefore requiring a gate voltage higher than the load supply voltage by V_G volts to switch the transistor on.

High-side switches in circuits with high load voltages have to switch the MOSFET gate between two voltages that can be much larger than the supply voltage of the controller and drive circuits. When using *n*-channel high-side drivers, one of these voltages will also be greater than the load supply voltage. For example, a controller and driver circuit working on 15V supply might have to switch the MOSFET's gate between 500V and 512V. Special techniques are required to do this and there are a number of methods available.

All Charged Up

Bootstrap high-side drivers charge a capacitor using a low voltage supply and switch the capacitor to the gate-source of the MOSFET to turn it on. This approach cannot hold the transistor on indefinitely as the bootstrap capacitor has to be recharged periodically (while the high-side MOSFET is off). **Charge-pump** high-side drivers use voltage multiplier circuits to generate the high gate voltage; they can be inefficient and slow, but they allow indefinite high-side on time.

A *pulse transformer* can be used to couple the control signal to the high-side gate, which is potentially a simple and low-cost solution, but can be quite difficult to get right in practice. A *floating power supply* can also be used for the high-side drive circuit with switching controlled via an opto-isolator; this is an expensive option as a separate supply is required for each high-side MOSFET used. This is not an exhaustive list of techniques and each has a number of variations on the basic idea.

We can use a single transistor to switch a load, or multiple transistors in *half-bridge* or *full-bridge* (H-bridge) configurations. The drivers for these configurations require the capabilities of both high-side and low-side drivers. We show two examples here, Fig. 5 is a half-bridge driver using a complementary pair of MOSFETs, and Fig. 6 shows a full-bridge using four *n*-channel devices.

An additional concern with half and full bridge circuits is the possibility that both transistors in a half-bridge may briefly switch on at the same time, resulting in and excessive *crossover*, or *cross-conduction current* flowing when we switch one transistor on and the other one off. Driver circuits must control the timing of the switching of the two transistors to prevent this from happening. Some drivers have adjustable "deadtime" – that is, the time during the changeover when both transistors in the half-bridge are off.

Take Control

The power MOSFET, like other MOSFETs is basically a voltage-controlled device, i.e. the gate-source *voltage* controls the drain current. In many power applications, the MOSFET is switched between fully on and fully off, by switching the gate voltage between 0V and some voltage well above its threshold value.

The use of a voltage well above the threshold ensures a saturated operation, in which the ON-resistance ($R_{DS(on)}$), voltage drop across the device, and also the power dissipation, are minimised. We can consider the device to be either in the *off* state where little or no power is dissipated, or the *on* state where power dissipation depends on $R_{DS(on)}$ and the drain source current.

This simple view is adequate for low switching frequencies, but when switching power MOSFETs at speeds greater than a few kilohertz we have to take account of the fact that the MOSFET's gate is a *capacitance* which has to be charged and discharged through the driver circuit's source resistance and the resistance of the wiring both inside and outside the device. Thus, the gate voltage will actually follow an *RC* charging curve, and the MOSFET will spend some time in-between being fully on and fully off.

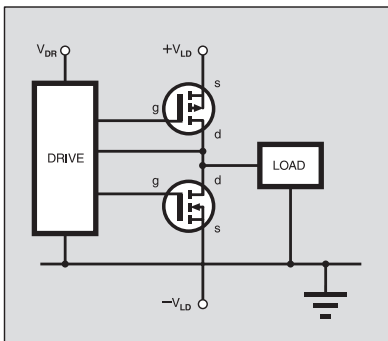

Fig.5. Half-bridge driver using a complementary pair of MOSFETs.

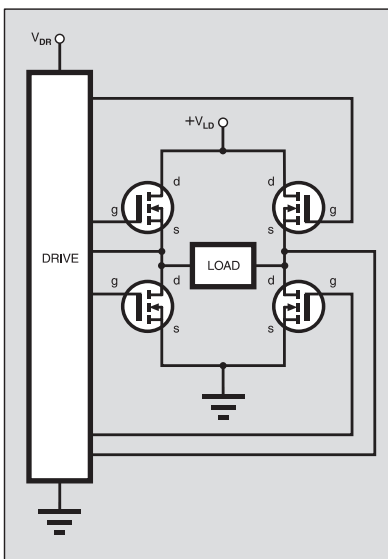

Fig.6. Full-bridge driver using *n*-channel devices.

During this time the device may dissipate a lot of power, a problem referred to as *switching losses*. The drive circuit therefore must be able to supply enough transient current to charge the gate capacitance at the required rate. In some cases this current may be quite substantial, particularly for large very high power devices, or where paralleled MOSFETs are being used.

As well as being too slow, it is also possible for power MOSFET circuits to

switch too fast, or put more accurately, for voltage or currents within the circuit to change too fast. Very fast current and voltage changes can damage devices and also cause more interference radiation than slower rates of switching. Careful design of the driver circuit may be required to get the switching behaviour correct, particularly in high speed and very high power applications.

Integrated Drive

Trying to design high quality power MOSFET driver circuits from scratch is not very easy except for relatively undemanding situations, particularly if high-side switching is required. Fortunately, there are many driver i.c.s available that do most of the work for you.

Some of them are used in, say, motor control circuits such as the ULN range from Maxim (www.maxim-ic.com). The MAX620 is a quad high-side MOSFET driver with integrated charge pump whilst the MAX621 has integrated capacitors as well. Allegro also publishes some very useful information on motor drivers and bridge drivers at www.allegromicro.com. Data sheets and product guides can be downloaded from the Internet.

Like all power switching circuits, MOSFET power circuits require good layout, in particular to minimise stray inductance in critical parts of the circuit. Proper thermal design and heatsink selection may be required. Some MOSFETs include built-in protection circuitry. The Philips TOPFET range (BUK100 type) has short-circuit and overload protection as well as over-temperature circuitry. *IMB*.

Simply Switching Speed

Your comment on the speed of shaded-pole motors (EPE Dec '02) is not totally correct, although, as you say, it is the practice to teach that their speed is governed by the supply frequency alone. However, in some fan heaters made by the English manufacturer Morphy Richards in the 1960s, the fan is given two speeds.

The lower speed is obtained by simply switching a wirewound resistor (of a few hundred ohms) in series with the mains input to the motor alone, simply reducing its applied voltage. I have a couple of these heaters and the speed control works fine. Howard Miles, by email.

The use of a series resistor is primitive but clearly you can get away with it if the mechanical loads are light. The only load that a typical fan heater sees is that of the fan blades coupled with the air resistance, and aided by decent ball-bearing races, the motor would have a constant load and probably not be working very hard.

One danger with typical fan heaters is that if the fanblade doesn't blow sufficient volumes of air over the resistance elements, then the heater will overheat and cut out (hopefully – otherwise it will catch fire). Mind you, I have a frenetic Ecco-brand fan heater that blew up when the metal fanblade flew off the squirrel cage motor and, with a bright blue flash, shorted out the elements completely! *ARW*.

WIND TUNNEL

JOHN BECKER

Scientifically investigate Nature's second essential element

A WIND TUNNEL can be used to investigate the effect of air flow on objects under controlled conditions, demonstrating, for example, how aircraft or bird wings create lift, or a vehicle's shape affects its streamlining.

In principle, a wind tunnel can be constructed using just a rolled tube of cardboard enclosing a fan, as the author did in the first instance. The sophistication, though, comes from adding rigidity to the construction and providing variable speed to the fan, plus a means of knowing at what rate the fan is moving air through the tunnel.

This design is intended for use with the *Wind Speed Meter* in the January '03 issue, but can also be used on its own. It has an easily constructed long rectangular wooden frame with clear perspex panels that enclose a fan at one end whose rotation rate is controlled electronically by a potentiometer. Air flow rate is variable from less than 1mph to around 8mph, although the range can be raised or lowered depending on the motor used and the tunnel's chosen dimensions.

An optically coupled sensor responds to a light beam being broken by the fan blades and a PIC microcontroller determines the fan's revolutions per second in relation to the number of fan blades. The result is shown on an alphanumeric liquid crystal display (l.c.d.). The pulse rate

detection circuit may be set to respond to fans having between one and nine blades.

The fan has an induction motor rated at 230V a.c. 26W. It is powered from a 12V car battery via a step-up variable frequency inverter. On-off switch S1 (shown in Fig.2) is optional. The author used heavy duty crocodile clips to connect the circuit to the car battery.

It is recommended that a line-mounted fuse (say 13A), should be used in the lead connecting to battery positive.

FAN CONTROLLER

The fan speed controller has been designed to convert d.c. power from the 12V battery into a 230V a.c. supply that powers the fan's induction motor. This type of motor requires frequency control to vary its speed and the controller is *not* usable with d.c. or other types of mains a.c. motor. Such motors require other techniques to change their speed. (A brief discussion of motor types was given in *Circuit Surgery* December '02.)

Current consumption from the battery is typically about 3A, but can rise to around 10A – more on this later.

The circuit diagram for the fan controller is shown in Fig.1. It is basically a variable frequency squarewave oscillator driving two gating *n-channel* power MOS-FET transistors in anti-phase. These alternately switch current from the 12V d.c.



supply through the twin low voltage windings of a transformer. The transformer is used in step-up mode and its high voltage winding powers the fan motor. Such a circuit is popularly known as an *inverter*.

The oscillator circuit is formed around the Schmitt inverter gate IC1a. Its frequency rate is set by capacitor C2 and the resistance across the feedback path comprised of potentiometers VR1 to VR3. VR1 is the panel mounted manual control, with VR2 and VR3 providing preset adjustment of the frequency range obtainable using VR1, as discussed later.

The output from IC1a is inverted by IC1b and drives transistor TR1. The output from IC1b is also inverted by IC1c to drive TR2. Consequently, when one transistor is turned on into full conduction, the other is turned fully off. Because the transistors are switching between the two extreme states, very little heat is generated across them, although a small amount of heatsinking is still required.

The transistors alternately sink current through the transformer's 12V windings, which are fed directly at their common junction from the 12V supply. The transformer's high voltage winding steps up the 12V a.c. switched power to around 230V a.c.

TRANSFORMER

It will be recognised that the transformer is simply a standard 230V a.c. mains transformer having two 12V a.c. secondary windings. In countries such as the USA where the supply is 110V a.c., rather than the 230V a.c. used in the UK, Europe and many other parts of the world, the transformer should be chosen as one having a 110V a.c. primary winding, but still with twin 12V a.c. secondaries.

The problem with stepping up an a.c. voltage is that the current available at the output is reduced by a similar but inverted ratio. Stepping up from 12V a.c. to 230V a.c. is a ratio of approximately 20:1 for the voltage, but the current available is then dropped by the inverse of that ratio, to 1:20.

The fan motor used in the prototype is rated at 26W. One of Ohm's Laws states that Amps = Watts divided Volts, $A = W/V$. When this 26W motor is powered at 230V a.c. the current required by it is $26W/230V = 0.113A$. The current required from the 12V a.c. windings is 20 times that, at 2.26A. The transformer's secondary winding VA



An easily constructed wood and perspex frame enclosing a fan and the controlling electronics.

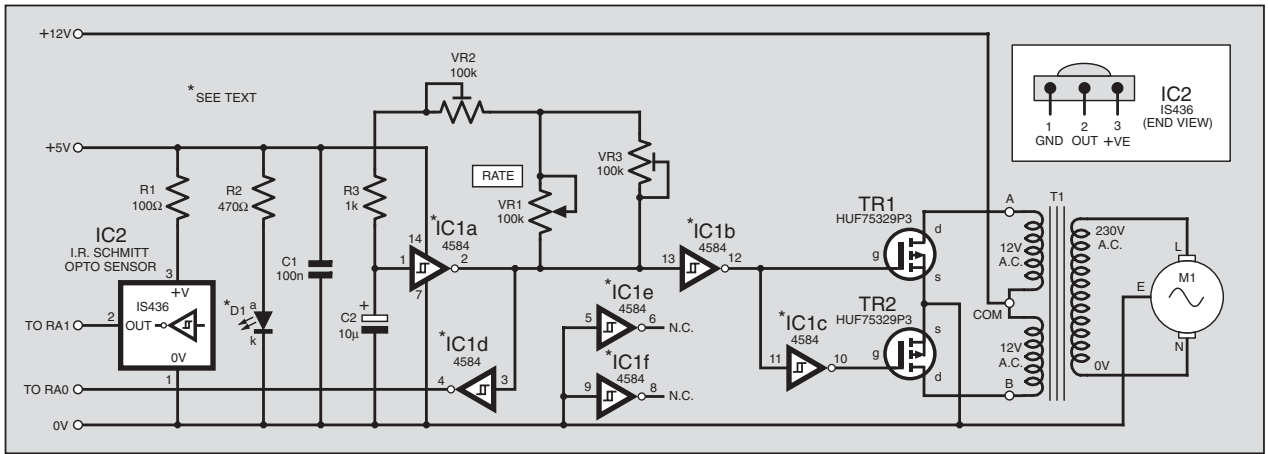

Fig.1. Circuit diagram for the variable speed fan controller, plus the opto-coupled fan rotation rate sensor.

rating required is thus a minimum of $12V \times 2.26A = 27VA$. A transformer with a VA rating for each secondary of 37.5VA was chosen to allow plenty of latitude, in other words a 75VA transformer.

SPEED SENSOR

Also shown in Fig.1 are the components for sensing the fan's rotational speed. A light source is provided by l.e.d. D1 on one side of the fan blades. On the other side of the blades is the light sensor, IC2. This detects the changing light levels when the blades rotate past the light source. It is a Schmitt trigger device and outputs line-level pulses in response.

For reasons of electrical stability, the l.e.d. and sensor are both powered from the +5V regulated line that supplies the PIC microcontroller (in Fig.2). Resistor R2 limits the current flow through the l.e.d.

Originally it had been intended that an infra-red l.e.d. and sensor pair should be used. However, the sensor was received prior to the l.e.d. and it was found that an ultra-bright red l.e.d. could be used just as effectively. Its obvious visibility is a benefit since it can be seen that it is functioning.

The sensor is quoted in the supplier's catalogue as having an internal voltage regulator and a TTL compatible output, which was taken to mean an output pulse range having a maximum swing of no more than 0V to 5V. Disconcertingly, when powered at 12V d.c. it was found that the pulse output was well above the expected +5V.

Searching the manufacturer's web site, a data sheet for this device could not be found. It was decided, therefore, that the sensor should be powered at 5V, with a nominal value of resistor (R1) included in its supply input path.

MICROCONTROLLER

Interpreting the fan's rotational speed from the pulsed output of the opto-sensor IC2 is performed by the PIC16F628 microcontroller shown in Fig.2. This is operated at 3.2768MHz, as set by crystal X1. The use of this clock rate is more convenient to the PIC's software than would be a clock rate generated by the PIC's internal RC oscillator.

The software repeatedly counts the number of incoming pulses received in one second at pin RA1 via resistor R5. It divides

the count by the fan blade quantity and the result is output to l.c.d. X2 as a revolutions per second (RPS) value.

It is worth noting that each change in pulse polarity is detected by the PIC, resulting in a count value twice that of the number of pulses actually received. The raw data value is thus divided by two as well as the fan blade count.

The l.c.d. is controlled in conventional 4-bit mode by PIC pins RB0 to RB5, in the author's standard order. Preset VR4 adjusts the l.c.d. screen contrast.

Switch S2 is used to set the fan blade quantity into the software, to a value of five for the suggested motor, but may be any value between one and nine as required. The switch input pin is biased normally low by resistor R6, the PIC responding to the 5V voltage on pin RA2 when the switch is pressed.

Induction motors inherently "slip" in relation to the frequency at which they are powered. This fact was discussed in the *Circuit Surgery* mentioned earlier. Consequently, it was felt to be of interest to show the controlling frequency rate in Hertz (Hz) as well as the fan's actual rotational rate in RPS.

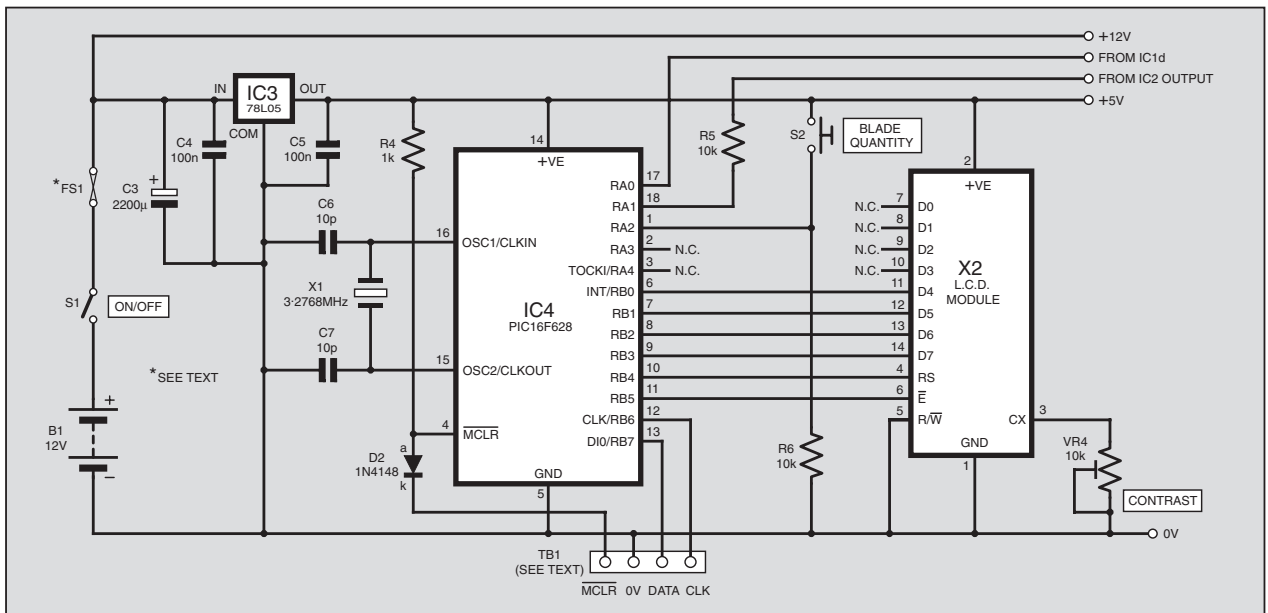

Fig.2. Circuit diagram for the microcontrolled fan-rate sensor and display.

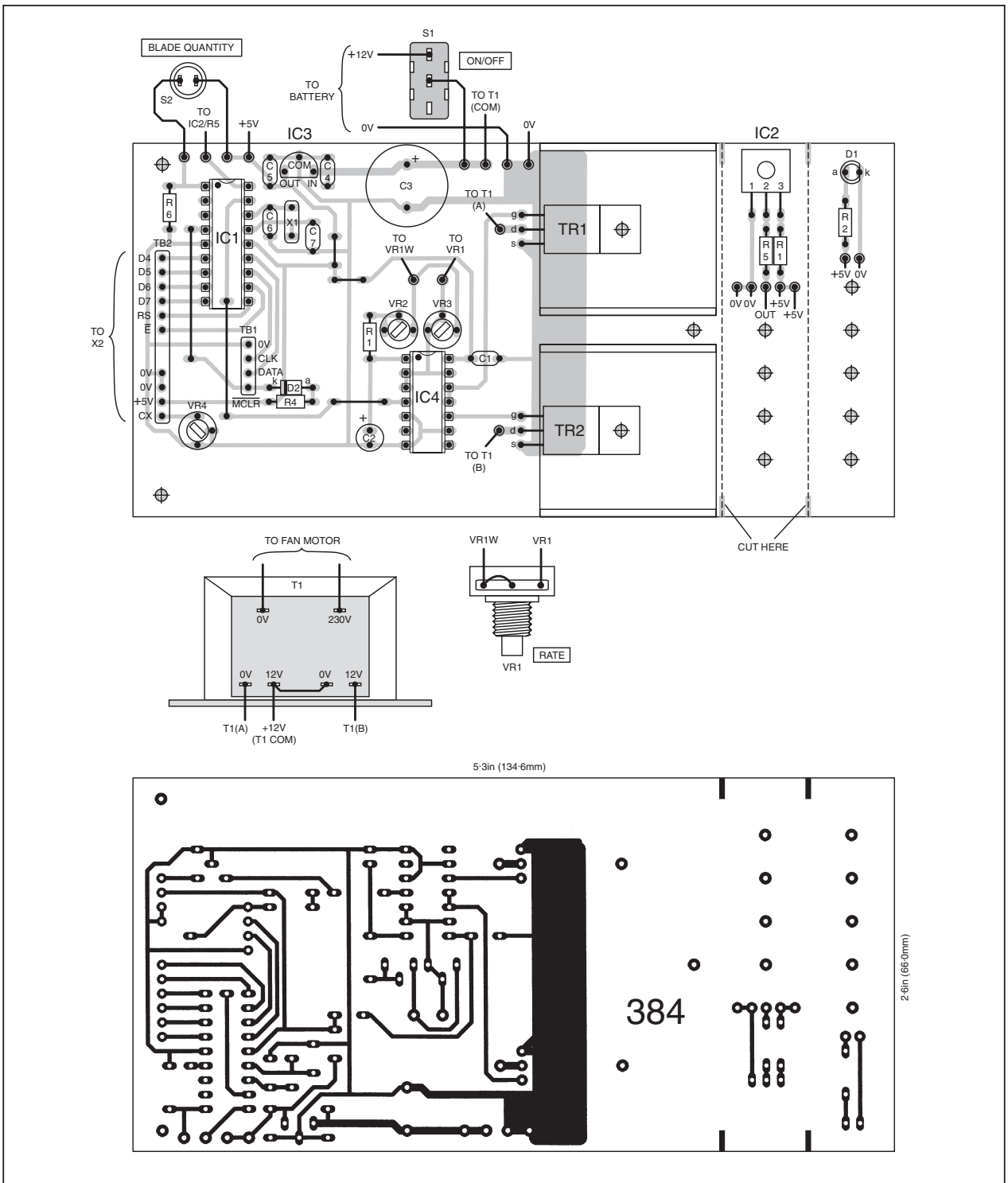

Fig.3. Printed circuit board component layout and full-size copper foil master track pattern for the Wind Tunnel. Note the two sub-strips that need cutting off prior to assembly.

The controlling frequency waveform is “tapped” by IC1d in Fig.1 and fed to PIC pin RA0. Here received pulse phase changes are also counted during one second. The resulting value is divided by two and output to the l.c.d. as a value in hertz.

The 12V battery supply is also fed to IC3, a +5V voltage regulator. It outputs +5V as required by the PIC, l.c.d. and the opto-sensing circuit (D1, IC2).

Capacitors C3 to C5 help to stabilise the power lines. The supply from the 12V battery is particularly susceptible to voltage

variation as the current flow through the transformer’s 12V windings reaches maximum during each cycle. Capacitor C3 helps to smooth this, but does not totally eliminate it. The voltage output by IC3 is unaffected by voltage changes on the battery supply line.

Resistor R4, diode D2 and connector TB1 allow the PIC to be programmed while in circuit on the board. However, this facility is only valid if you are wishing to re-program a previously programmed PIC16F628. It should not be used to program a brand new PIC.

This is due to the PIC16F62x family (and the PIC16F87x family) having configuration values set during manufacture that can prevent these devices from being first programmed when some PIC pins are connected to external components. Brand new PICs must therefore be programmed in a PIC programmer to which external components are *not* connected.

CONSTRUCTION

It is essential that you treat this design as though it is powered directly from the mains a.c. supply. Observe normal

COMPONENTS

Resistors

R1	100Ω
R2	470Ω
R3, R4	1k (2 off)
R5, R6	10k (2 off)

All 0.25W 5% carbon film.

See
**SHOP
TALK**
page 71

Potentiometers

VR1	100k rotary carbon, lin.
VR2, VR3	100k min. preset, round (2 off)
VR4	10k min. preset, round

Capacitors

C1, C4, C5	100n ceramic disc, 5mm pitch (3 off)
C2	10μ radial elect. 10V
C3	2200μ radial elect, 25V
C6, C7	10p ceramic disc, 5mm pitch (2 off)

Semiconductors

D1	red l.e.d., ultrabright, 5mm
D2	1N4148 signal diode
TR1, TR2	HUF75329P3 n-channel power MOSFET (2 off)
IC1	4584 or similar CMOS Schmitt hex inverter
IC2	IS436 infra-red Schmitt opto-sensor
IC3	78L05 +5V 100mA voltage regulator
IC4	PIC16F628 microcontroller, pre-programmed (see text)

Miscellaneous

S1	s.p.s.t. 15A heavy-duty, low voltage, switch (optional – see text)
S2	min. sp. push-to-make switch, panel mounting.
X1	3.2768MHz crystal
X2	2-line 16-character per line alphanumeric l.c.d. module
TB1	1mm 4-way pinheader (optional – see text)
M1	230V a.c. 26W fan with induction motor (plus two matching safety grilles)
T1	mains transformer, 75VA, 230V a.c. primary, twin 12V a.c. secondaries, 37.5VA each
FS1	fuse, 13A and in-line holder (optional – see text)

Printed circuit board, available from the *EPE PCB Service*, code 384; TO220 finned heatsink, 14°C/W (2 off); 18-pin d.i.l. socket; 14-pin d.i.l. socket; p.c.b. supports, self-adhesive (3 off); nuts and bolts to suit; heavy duty cable (see text); third safety grill (see text); 1mm terminal pins; connecting wire; solder, etc.; materials for tunnel (see text).

Approx. Cost
Guidance Only

£45

excl. fan and tunnel hardware

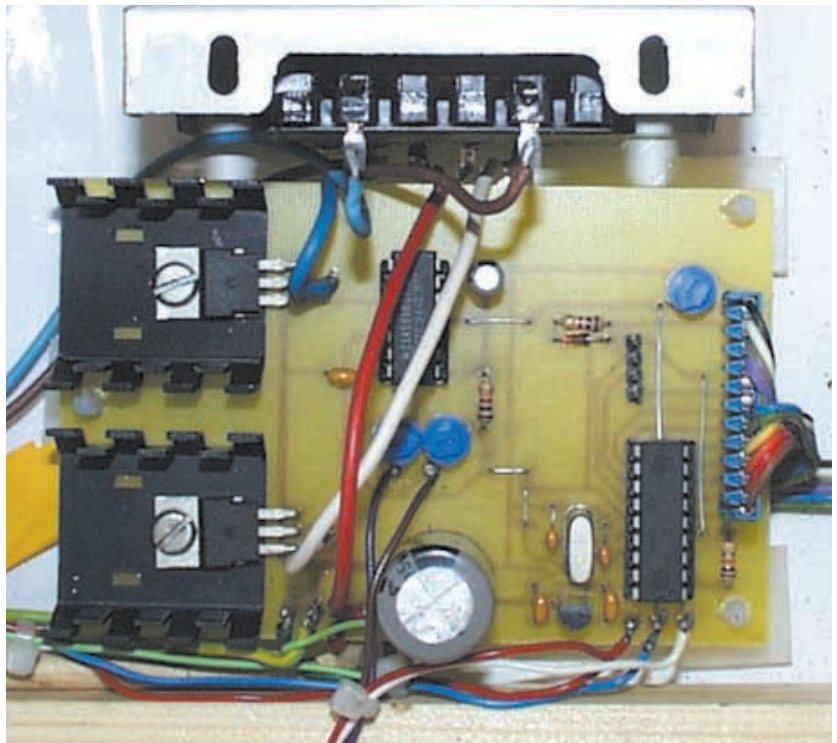

Wind Tunnel assembled p.c.b. See later regarding transformer position.

mains safety precautions at all times. Do not come into contact with the 230V a.c. output from the transformer.

Only construct this project if you are competently experienced at constructing mains powered circuits, or are supervised by someone who is suitably qualified.

The circuits in Fig.1 and Fig.2 are assembled on a single printed circuit board (p.c.b.) whose component and track layout details are shown in Fig.3. This board is available from the *EPE PCB Service*, code 384.

Before assembling the board, first cut off the two end strips which are used for mounting l.e.d. D1 and sensor IC2 on either side of the fan.

Then assemble the main board in order of component size. Do not insert IC1, IC4 or connect the l.c.d. until the correctness of the +5V supply from IC3 has been checked. Ensure the correct orientation of the other semiconductors and the electrolytic capacitors. Treat all i.c.s, transistors and the l.c.d. as CMOS devices and touch a grounded item of equipment to discharge static electricity from your body before handling them.

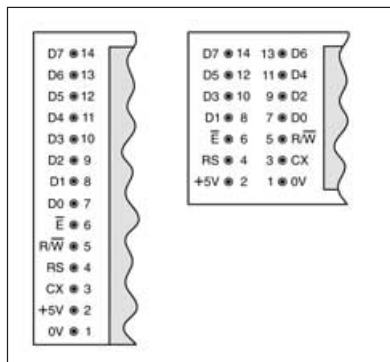

Fig.4. The two "standard" l.c.d. module pinout arrangements.

Transistors TR1 and TR2 require a heatsink to be used with them. Using thin-nosed pliers, bend their leads downwards so the transistors sit with their backs down against the board. Loosely insert the leads into their holes, slide the heatsinks in behind the transistors, and bolt the sandwich to the p.c.b. through the holes provided. It may be necessary to enlarge the p.c.b. holes to suit the bolts. Then solder the transistor leads to their copper pads.

Use 1mm terminal pins for all off-board connection points.

Assemble the components on the two cut-off p.c.b. strips, again correctly observing orientation. Connect leads to these strips, to switch S2 and potentiometer VR1, using leads longer than ultimately required, and solder to the designated points on the p.c.b., but only after the 5V power supply has been checked.

Do not connect the board to the transformer yet.

INITIAL TESTING

Having thoroughly checked the boards for incorrect component positioning and poor soldering, connect the main board to any 12V d.c. supply. Immediately check that +5V is present at the output of regulator IC3. When satisfied, disconnect power, insert the pre-programmed PIC (see later) and IC1, and connect the l.c.d., whose typical pinouts are shown in Fig.4. Also connect the two sub-boards.

Applying power again, adjust preset VR4 so that the l.c.d. screen contrast is satisfactory. A screen display similar to that in the photo below will be seen (but with different values). L.E.D. D1 should be lit brightly.



Typical running mode screen.

There are three factors displayed on the l.c.d. screen, their captions on the upper line and values below. To the left the present fan speed in revolutions per second (RPS) is displayed, which should be zero at this time.

In the centre, the fan speed oscillator rate (Hz) should be displayed and be variable by adjusting potentiometers VR1 to VR3. At the right, the fan blade count is shown, a value of one at this time (subject to the criteria stated in the Setting Blade Count section).

Point the l.e.d. strip towards the sensor on the other strip. Monitor the sensor output on a voltmeter. Check that the voltage is at +5V when the l.e.d. shines on the sensor, but drops to 0V when the sensor is darkened. Moving your hand rapidly back and forth between the l.e.d. and sensor, the RPS value on the l.c.d. should change accordingly (to a waves per second count!).

Now adjust presets VR2 and VR3 so that potentiometer VR1 changes the frequency range between about 40Hz and 250Hz. Preset VR2 sets the maximum frequency when VR1 and/or VR3 are at minimum resistance. VR3 adjusts the total resistance of itself in parallel with VR1, so setting the effective span range of VR1. Note that this setting also affects the lowest frequency that is available when VR1 is at maximum resistance.

Adjust the presets patiently until the desired range is achieved, as displayed in hertz on the l.c.d. Set VR1 so that a frequency of roughly 50Hz is being generated. Switch off again.

SETTING BLADE COUNT

To set the PIC program to suit the number of fan blades, disconnect the power. Then press switch S2 and hold it pressed while the power is reconnected. With power on again, release S2. This action sets the program into blade setting mode. (A toggle switch is shown in the photographs, but a push-switch is preferable.)

The l.c.d. screen will show the message SET BLADE COUNT on line one, with a value below it on line two. If the PIC has been programmed using the embedded data EEPROM value (see later), the value will be one. Otherwise any symbol may appear on line two. Repeatedly press switch S2 until the blade count suited to your fan is shown, as a number between 1 and 9. Following 9, the count will roll over to 1 again, and then upwards once more.



Typical blade count setting screen.

Each switch press causes the shown value to be stored in the data EEPROM at location 0. It is retained there until changed at some future time, even after switching off power. It is automatically recalled next time power is connected.

Disconnect power, wait a second or so, and power up again. The program is now back in normal run mode with the amended fan blade count displayed.

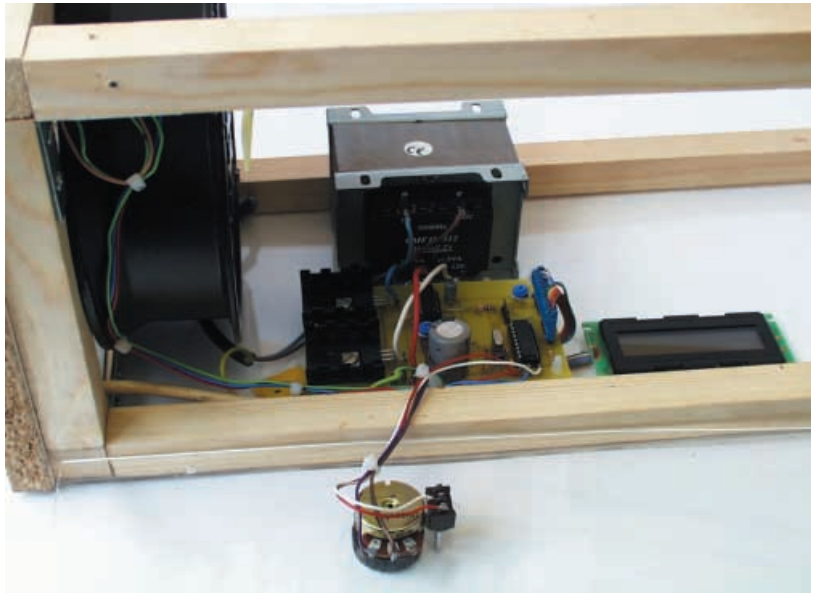

Relative positioning of components within the frame, but note later comments regarding transformer housing.

It is expected that once the blade count has been set it will never need changing again.

TRANSFORMER TEST

Using 13A cable, connect the transformer secondary windings to their respective p.c.b. connection points. **From here-on, fully observe standard mains safety practice.**

Connect a multimeter set to a range suited to 250V a.c. across the output terminals of the transformer's high voltage (230V a.c.) winding. Reconnect power, which should now be supplied by a 12V car battery via 13A twin cable, and check that an alternating voltage is being generated.

The actual reading is likely to vary between different multimeter types. Most are likely to be influenced by the square wave nature of the controlling input waveform. A reading of around 170V a.c. is to be expected, rather than 230V a.c. which would be expected if the input waveform were sinusoidal.

Observing the output waveform on an oscilloscope set to a suitable a.c. range, the waveform should appear as roughly square shaped with a peak-to-peak amplitude of about 350V. Varying the control frequency should not significantly affect the amplitude/voltage. This scope check is not essential.

Finally set VR1 for 50Hz and disconnect power.

FAN POWER

Once the fan has been connected, the following precautions should be observed:

To minimise stress to the power conversion circuit and the fan, it is recommended that you always power up with VR1 set to about 50Hz or so. This allows the fan to more readily start rotating and reach operational speed.

It is advisable not to switch power on when VR1 is set for a Hertz value less than about 40 as current consumption will be higher than normal until the fan speed stabilises.

FAN TEST

Now connect the fan to the transformer, using mains-rated cable of at least 2A. Cover the connections with insulating tape. Connect the fan's earth point to the 0V line (battery negative) at the p.c.b. Normal low current connecting wire will suffice for this. A nut and bolt, plus shake-prove washers, may be needed to connect the wire to the fan's frame. Scrape away any paint on the frame at that point to ensure good electrical contact is made.

Be fully aware that now not only do electrical safety precautions have to be observed, but also mechanical ones. The fan could cause injury if you touch its rotating blades. Beware that it will continue rotating for quite some time even after power is disconnected.

Support the fan firmly on a flat horizontal surface, allowing good air flow clearance in front and behind (say half a metre – 18ins), clearing loose objects that could

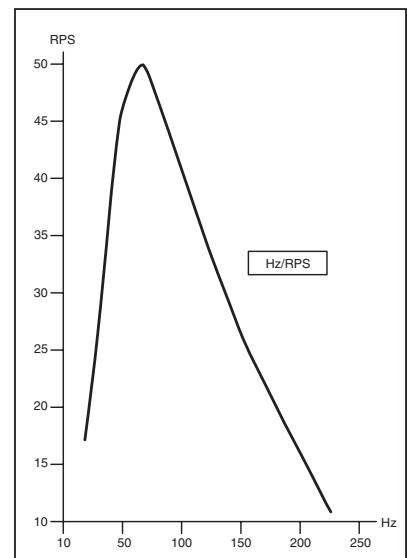
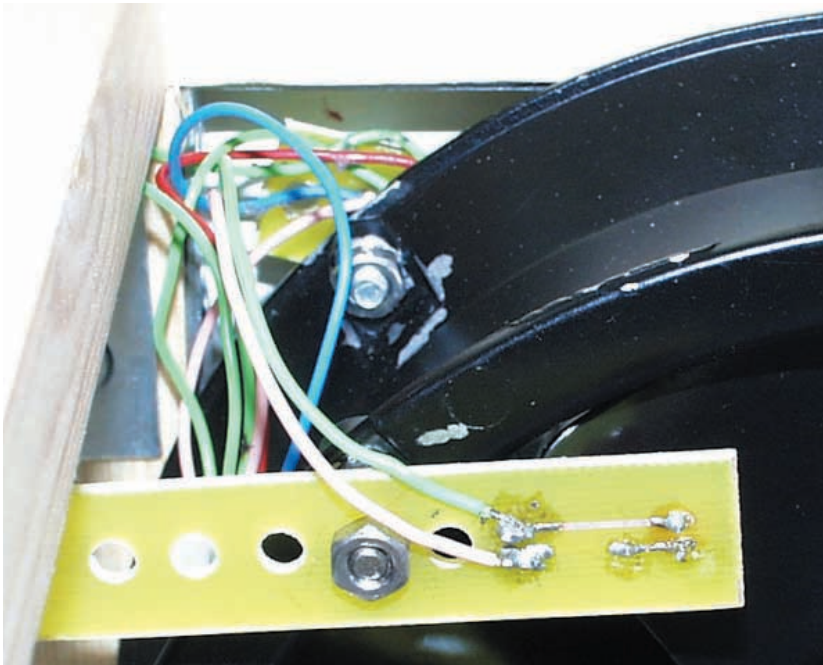

Fig. 5. Relationship between fan rotation rate and controlling frequency.



Sub-board holding l.e.d. mounted on the fan case. The opto-sensor is mounted similarly on the other side.

be drawn into the flow, or be dispersed by it at the output end.

Insert a meter capable of reading at least 10A d.c. in series with the 12V positive power supply lead.

With VR1 previously set for a control frequency of about 50Hz, re-apply power. While jointly observing the ammeter reading and the l.c.d., slowly vary the setting of VR1 across its full range. The fan's rotational rate should be fastest at around 50Hz, becoming slower for rates to either side of this (see the graph in Fig.5). The current drawn from the battery will increase for frequencies below about 50Hz, and decrease above that rate (Fig.6).

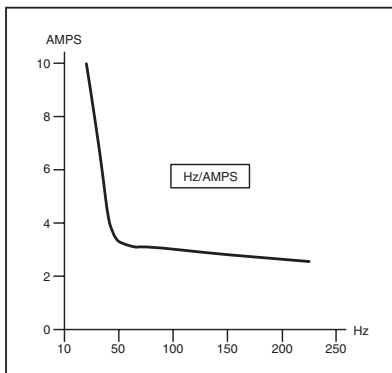

Fig.6. Relationship between fan controlling frequency and current consumption.

It will also be seen on the l.c.d. that the fan's RPS rate at and below 50Hz lags behind the control rate (Hz). For example, you might typically see an RPS rate of 48 when the control rate is 50Hz. This is due to the nature of induction motors – there is slippage between the control frequency and the rotational rate. This fact is discussed in the previously mentioned *Circuit Surgery* article.

From the graphs produced using the prototype's measured values, it will be seen that the fan speed is most economically

controlled by varying the control frequency upwards above 50Hz, rather than below it. As the current graph shows, significantly high currents can flow at slow rotational speeds. These could endanger the transformer and the motor.

Before you put the tunnel into active service, it is recommended that you readjust the frequency range covered by VR1 so that currents no greater than about 4A can flow into the transformer.

When observing the multimeter's displayed amperage value, be aware that it will fluctuate. This is due to the current varying at different points in the controlling waveform's cycle. It is the peak values that are most significant.

TUNNEL CONSTRUCTION

The prototype tunnel hardware was designed expediently. That is, the framework was given dimensions to suit the fan diameter and the width of the perspex sheet already purchased. The tunnel's external framework dimensions are 20cm × 20cm × 61cm (7.8in × 7.8in × 24in).

Hardwood battens having a thickness of 20mm × 20mm (0.8in × 0.8in) were used for the frame, joining each section by means of angle-brackets at the corners. If the wind tunnel is to be used in a school, the frame construction might be a suitable project for a woodworking class, employing traditional woodworking skills such as dovetail or mortice and tenon joints.

Plastic covered chipboard (Contiboard) was used for the front plate. A hole of the same diameter as the fan's opening was made by drilling many holes round the circle's internal perimeter, followed by chiselling through the thin walls between the holes, and then smoothing with a power drill attachment.

Mistakenly, the tunnel's height and width dimension were cut so that the structure would just enclose the fan assembly, with the fan mounted inside and against the front framework (as seen in the photographs).

With hindsight, it would have been better to have increased the height and width so that the fan could then be mounted immediately behind and onto the front plate. This would have allowed shorter bolts to be used, and perhaps have provided greater long-term structural stability.

The downside is that the internal cross-sectional area of the tunnel would have been larger, resulting in a slower maximum air flow rate (see later).

INTERNAL LAYOUT

It will be seen in the photographs that the printed circuit board and the transformer are both enclosed within the tunnel. This is fine for the p.c.b. and l.c.d. as they will not significantly affect the air flow in the positions shown. Indeed the air flow will help the power transistors and their heatsinks to remain cool.

The transformer, though, is only in the position shown for the author's convenience. Its bulk near the entry to the fan will impede the air flow. It is recommended that the transformer is enclosed in a separate case made from robust plastic and mounted on the outside of the tunnel, with the power leads passing through holes to the motor and p.c.b. Cable grommets should be used to prevent air flow from entering the tunnel via the cable holes.

OPTO SENSOR MOUNTING

When mounting the fan inside the tunnel, the two small p.c.b.s with their l.e.d. and opto-sensor components should be mounted at the same time. In the prototype, the fan's frame had two mounting bolt holes on the front and back. The bolts through the holes were also used to mount these p.c.b.s. The Schmitt trigger sensor board was mounted on the exit side of the fan, using several nuts to position and secure it correctly. Note that the fan sucks the air through the Tunnel.

The l.e.d. board was mounted on the fan's air entry side, using several nuts on a separate bolt (see photo).

The p.c.b.s. have been designed with several bolt holes to facilitate choice of mounting position. Any excess p.c.b. length can be cut off. Position the two assemblies so that they intrude into the air flow path as little as possible. Allow adequate clearance from the fan blades so that they cannot hit the assemblies.

Ensure that when the fan rotates, the l.e.d. and sensor are in clear line of sight of each other when a blade gap is open between them. Tidy the wires between the two boards after mounting them, allowing adequate length to also connect back to the main p.c.b. Use cable ties to harness the wires and secure them so that they cannot be drawn into the air path feeding the fan.

SAFETY GRILLES

The importance of using safety grilles with this tunnel cannot be over-emphasised. It is imperative that at least two should be used – one each on either side of the fan. The external one is shown in the first photograph (an internal one had not been installed at the time of photography). It is also recommended that an additional grille should be inserted between the p.c.b. and the air input side of the tunnel, mounting it close to the p.c.b.

The two main grilles are available as accessories designed for use with the suggested fan. The third grille may need to be improvised to suit the tunnel dimensions. Narrow gauge chicken-wire might serve the purpose without impeding the air flow.

The grilles not only help to prevent fingers from being sliced off, but also help to prevent objects placed within the tunnel being drawn into the air flow and the fan blades or onto the p.c.b. assembly.

FINAL INSTALLATION

When the tests have been completed and the fan mounted, the tunnel can have the electronic assemblies finally (and securely) installed. The p.c.b. was mounted using self-adhesive p.c.b. supports. Drill suitable holes in the perspex and mount VR1 and switch S2.

It is suggested that VR1 is provided with a scale, calibrated in hertz. Calibration for rotation speed could be added too, but note that the values will not be accurate until the fan stabilises for a given hertz value. Calibrating for wind speed is perhaps inappropriate since it can change depending on what objects are within the tunnel.

Finally, screw down the perspex covers. The wind tunnel is then ready to be put into service and the characteristics of air in motion can be scientifically investigated.

AIR FLOW RATE

Five factors govern the maximum rate of air flow that can be achieved at any point in the tunnel:

1. Fan capacity
2. Internal dimensions
3. Presence of internal obstructions
4. Restriction of air flow into and out of tunnel ports
5. Turbulence in the air flow

The volume of air that a fan can move in a given period of time is quoted in the supplier's catalogue. The fan used by the author is RS Components type 223-130. This has the capacity to move air at a rate of 129 litres per second.

A litre represents a volume having dimensions of 10cm × 10cm × 10cm. A rate of one litre per second can therefore be expressed as a cube linearly moving at 10cm per second. This extrapolates to 60sec × 60min × 10cm = 36000cm = 0.36 kilometres per hour. A capacity of 129 litres per second is thus a rate of 46.44kph = 29mph for a one litre cube. Or, to put it in terms of a wind tunnel, if a square-shaped tunnel's cross-section measures 10cm × 10cm, a molecule of air in that tunnel will move at 29mph.

The nominal cross-sectional dimensions within the prototype tunnel's perspex sides are approximately 20cm × 20cm, an area four times that of the volume in the previous paragraph. The maximum rate at which the air can be moved by the fan is thus 29/4 = 7.25mph (11.6kph).

In fact, because the internal dimensions of the prototype are intruded upon by the thickness of the framework battens, the effective dimensions are smaller, and the theoretical maximum air flow rate somewhat faster than the above.

Performing tests in the tunnel with the fan driven directly by 230V 50Hz mains a.c., the maximum air flow rate was measured to be a fraction above 8mph (12.8kph).

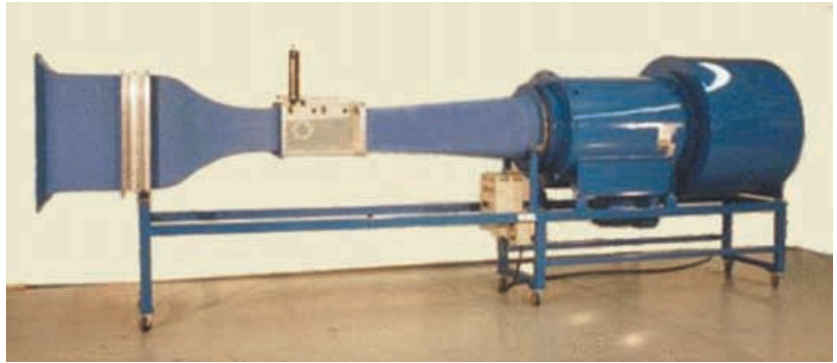

Example of a commercial wind tunnel, approximately 6 metres (20 feet) long, using a 7.5kW motor. Courtesy www.eldinc.com (Engineering Laboratory Design Inc).

However, the efficiency of the fan is only maximised when the controlling power is sinusoidal at the manufacturer's stated design power and frequency. The squarewave power from the step-up transformer causes the fan to operate less efficiently. Under variable control, the measured maximum air flow rate was found to be about 6.8mph (10.9kph).

FLOW PATHS

It will be seen that if the tunnel's cross-sectional dimensions are increased, the maximum obtainable air flow rate will fall accordingly.

However, this is not necessarily an adverse situation. During other tests, it was found that many experiments were best performed at slower air flow rates. This was particularly true when smoke trails were used during observation of air flow patterns across objects within the tunnel.

It is worth recognising that the simple act of inserting an object in the tunnel will variously affect the air flow rate at different points within it. For instance, air flowing past the object will move faster than that in the unoccupied tunnel regions.

Also of interest is the fact that the air flow pattern will be influenced by the internal shape of the tunnel, and the shape of its air entry and exit openings.

Air entering the tunnel is drawn from all directions around the tunnel, including from the front. It then meets the square shape of the entry port, which has acute edges on the frame battens. As the air meets these edges and has to curve around them, turbulence is caused. Further turbulence is caused by the friction between the air and the perspex sides and more batten surfaces. Then the suction of the fan draws the air into a cone before passing the rotating blades.

On the exit side of the fan, the moving air then meets resistance as it collides with the external air. Whilst this will not directly affect the turbulence within the tunnel, resistance at the fan's exit will affect the rate of air flow within the tunnel.

This can be easily demonstrated once the tunnel has been completed, by bringing a book towards the fan's exit, and observing how the *Wind Speed Meter* shows the air flow slowing as the book gets closer. Do not attempt to fully prevent air escaping from the exit as this could stress the fan motor and possibly damage it.

The previous few paragraphs give hints at some of the experiments and observations

that can be made just on the tunnel itself. The use of the *Wind Speed Meter* and of "smoke trails" as discussed later should provide some informative results.

Professionally manufactured wind tunnels have internal surfaces shaped and smoothed to reduce unwanted turbulence as much as possible. As can be seen in the photograph of a commercial wind tunnel, the entry and exit ports are also shaped to help minimise input turbulence and output resistance.

EXPERIMENTS

Investigative experiments should include checking the rate of air flow through the tunnel in terms of a quantified distance per unit of time in respect of the fan's rotational rate.

This is where again the *Wind Speed Meter* can be used, inserting it into the centre of the tunnel and noting its readings against the tunnel's l.c.d. readings showing RPS and Hz. The measured results of varying fan RPS in relation to air speed in miles per hour are shown in Fig.7.

In the *Wind Speed Meter* article, the author raised the question of whether or not fan rotation rate is linearly related to wind speed. The graph in Fig.7 confirms that it is over the range tested.

The wind tunnel can be used effectively in several ways. As one example, it can be used to demonstrate how a standing object can be toppled by wind. We already know this from experience, but the tunnel can quantify the relationships between object stability and wind speed.

Another example is to demonstrate how air flow can cause aircraft wings to provide lift, and how the shape of the wings can affect this. The models must, of course, be light enough to be lifted by the tunnel's air flow. Small balsa wood models might be suitable, although this has not been tested. Paper models could also be used if made rigid enough.

SMOKE TRAILS

The pattern of the air flow itself can be observed if a suitably visible substance is injected into it (see photo). A variety of smoke generating methods are widely employed, but all based on materials that are variously either flammable, smelly and/or messy.

The object is to demonstrate how air flow paths are changed by an object in their midst. An understanding of vehicle streamlining can be obtained in this way, for example.

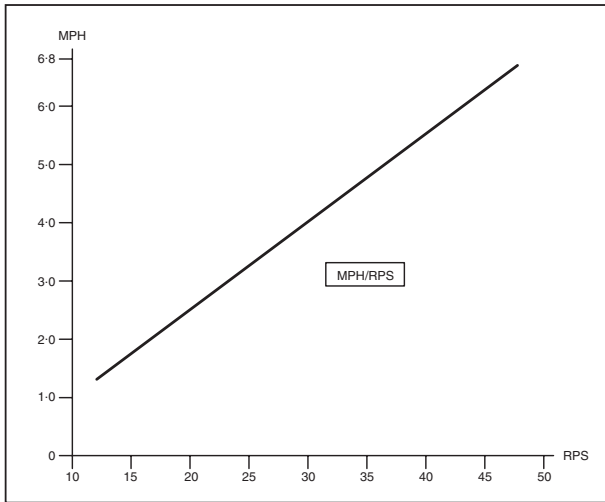

Fig. 7. Relationship between air flow in m.p.h. and fan rotation rate in the empty prototype tunnel.

For the sake of the photograph, a plumber's smoke cartridge was used. These can be bought from centres specialising in plumber's materials. Those bought by the author provided about 30 seconds of smoke from each capsule. However, they are slightly expensive, and very smelly!

The same applies to plumber's matches, which smoke well for several seconds. These two materials are apparently used by plumbers when checking for air flow in flues and ventilation ducts.

Another option is traditional bee-keeper's smoke, as used to pacify bees. It is typically comprised of various wood and cardboard materials that burn slowly giving off smoke. Questioning bee-keepers at County Shows, it seems that different bee-keepers are likely to use their own customised materials, with recipes differing depending on who is asked!

At one show it was suggested that a modern chemical "liquid smoke" might be a suitable alternative. This was said to be squirted from a can without the need for combustion. Further research, though, revealed that this substitute is not too visible and that it is the aroma that pacifies the bees, not its appearance.

shops and the like. Several web sites mention Roscoe Fog Machines, which might be worth investigating. The name Mole-Richardson (well known in the film-industry) also showed up in the context of fog machines.

Other possibilities that showed up when doing a web search via www.google.com are:

- smoking candles
- thin opaque fluid squirted into the airstream from a fine nozzle
- fine white powder "drizzled" into the airflow
- soap bubbles such as are generated by some children's toys
- fine sawdust
- mineral oil dripped onto a wire heated sufficiently to cause the oil to smoke

Web site file www.eng.fsu.edu/~alvi/EML4304L/alpha/node15.html shows an example of the latter. Other sites (names not recorded) suggested ni-chrome smoke wire, and resistance wire such as that used with the bars of electric fires.

Only plumber's smoke has been used by the author and no opinion on the other techniques can be offered.



Smoke trail across a car-shaped computer mouse, using a plumber's smoke capsule as the source. Thinner trails from a nozzle-shaped source would provide better detail. Note how the air flows over the profile and then pulls back in towards the shape to fill the partial vacuum created.

ORIGINS

Web site www.eldinc.com/wind_tunnel/wind_tunnel.htm offers the following on the origins of wind tunnels:

Wind tunnels were developed during the late 1880's when it was recognised that outside conditions were too uncertain to plan and execute the testing required to aid in man's quest to fly. As John Smeaton, in a paper read before the Royal Society in 1759, stated: "In trying experiments on windmill sails, the wind itself is too uncertain to answer the purpose, we must have recourse to an artificial wind".

It is not said how this was accomplished.

Another possibility is to use dry-ice. Theatres and discos frequently use dry-ice generating machines to simulate smoke drifting across a floor. Such machines are available from disco equipment hire

Care must be taken, of course, to ensure that slow air flow speeds do not allow any trail substances to settle on the fan or the circuits.

It is recommended that if trails of some sort are to be used extensively, an air extraction duct of the type used with domestic tumble dryers should be secured to the tunnel exit and fed outdoors through an associated extraction vent.

Tell the author via *EPE* what trail method you find best once you get to know the tunnel.

A final note of caution – do not place anything in or near the tunnel that could be damaged by the air flow or contact with the fan blades.

SOFTWARE

Software for the PIC microcontroller used in this design is available on a 3.5in disk from the *EPE* Editorial office. A nominal charge applies to cover admin costs. It is also available for free download from the *EPE* ftp site. The easiest access route to this is via the *EPE* web site at www.epemag.wimborne.co.uk. At the top of the home page, there is a menu item stating *FTP Site (Downloads)*. Click on this, then follow along the folders path PUB/PICS/WindTunnel. Open the latter folder and download the files required.

There are two files, having extensions .ASM (TASM grammar assembly source code), and .HEX (MPASM format hex code for programming into the PIC via a suitable programmer, e.g. *Toolkit TK3*).

The HEX file has data EEPROM and configuration values embedded in it. For those whose programmers do not handle such embedded values, the configuration is crystal XT, POR on, WDT, CP and all other options off. Only a single data EEPROM value is used, the fan blade quantity, and this can be set via switch S2 as discussed earlier.

Pre-programmed PICs are available as stated on this month's *Shoptalk* page. Details of where to buy some of the other components for this design are also covered there – read it!

WEATHER FORECAST

This wind tunnel and the *Wind Speed Meter* were originally designed to test the viability of using ultrasonic techniques to measure wind speed and direction, for use in a forthcoming "multi-function" Weather Centre and Logger. It has long been promised, and just needs a bit more work on it under "garden conditions" – when much warmer weather prevails! It is both "standalone" and with a PC interface that allows weather conditions to be displayed graphically. □

INGENUITY UNLIMITED



Our regular round-up of readers' own circuits. We pay between £10 and £50 for all material published, depending on length and technical merit. We're looking for novel applications and circuit designs, not simply mechanical, electrical or software ideas. Ideas *must be the reader's own work and must not have been submitted for publication elsewhere*. The circuits shown have NOT been proven by us. *Ingenuity Unlimited* is open to ALL abilities, but items for consideration in this column should be typed or word-processed, with a brief circuit description (between 100 and 500 words maximum) and full circuit diagram showing all relevant component values. **Please draw all circuit schematics as clearly as possible.** Send your circuit ideas to: Alan Winstanley, *Ingenuity Unlimited*, Wimborne Publishing Ltd., 408 Wimborne Road East, Ferndown Dorset BH22 9ND. (We do not accept submissions for *IU* via E-mail.) Your ideas could earn you some cash and a prize!



WIN A PICO PC BASED OSCILLOSCOPE WORTH £586

- 100MS/s Dual Channel Storage Oscilloscope
- 50MHz Spectrum Analyser
- Multimeter • Frequency Meter
- Signal Generator

If you have a novel circuit idea which would be of use to other readers then a Pico Technology PC based oscilloscope could be yours. Every 12 months, Pico Technology will be awarding an ADC200-100 digital storage oscilloscope for the best *IU* submission. In addition, a DrDAQ Data Logger/Scope worth £69 will be presented to the runner up.

Single-Cylinder Ignition – Bright Spark

The circuit diagram shown in Fig. 1 is for an electronic ignition circuit for a single-cylinder engine, and was created when the magneto ignition coil on a 5hp lawnmower engine failed in open-circuit mode. It functions as follows: 12V is fed from the engine's battery to the original contact points via diode D2 and resistor R1. When the points are closed, the gate (g) of TR2 is held at 0V which allows the gate of power MOSFET TR5 to be pulled up to +12V, thereby allowing current to flow through the primary winding of the engine's ignition coil T1.

When the points open, TR2 is turned on which in turn pulls down the gate of TR5 thereby cutting power to T1 primary and creating a spark in the spark plug. Components D2, C2 and C3 provide a reasonably stable voltage bus for the

low-power side of the circuit as the rapid switching of T1 causes a lot of electrical noise. The l.e.d. D3 provides a visual indication of the status of T1 at cranking speeds and is also useful for testing.

Shutdown

Should the engine stop for a reason other than the operator switching the ignition off (e.g. running out of petrol) then a condition may occur whereby the points remain closed which would lead to the destruction of TR5 and/or the coil T1. Should the points remain closed therefore, the gate (g) of TR3 is pulled to ground (0V) thereby allowing TR4 to turn on once the voltage on capacitor C1 reaches its gate threshold voltage, i.e. in about two seconds. The MOSFET TR4 then grounds the gate of TR5 and shuts off current to the ignition coil. As soon as

the points open again, normal operation is restored.

Components TR1, R2 and Zener diode D1 provide a TTL-compatible pulse output which was actually used as an input to a PIC-based tachometer circuit. Diode D4 protects TR5 from the nasty spikes created by the inductive nature of T1.

All resistors are standard 0.25W 5% carbon. Ignition coil T1 may be sourced from either a breaker's yard or a motor factor. The type used in the prototype was designed for electronic ignition and needed no ballast resistor, however one *must* be included otherwise TR1 must be adequately heatsinked. Component choice is not critical and any equivalents may be used so long as they meet or surpass the spec. of the specified parts.

*Damien Maguire,
Greystones, Ireland.*

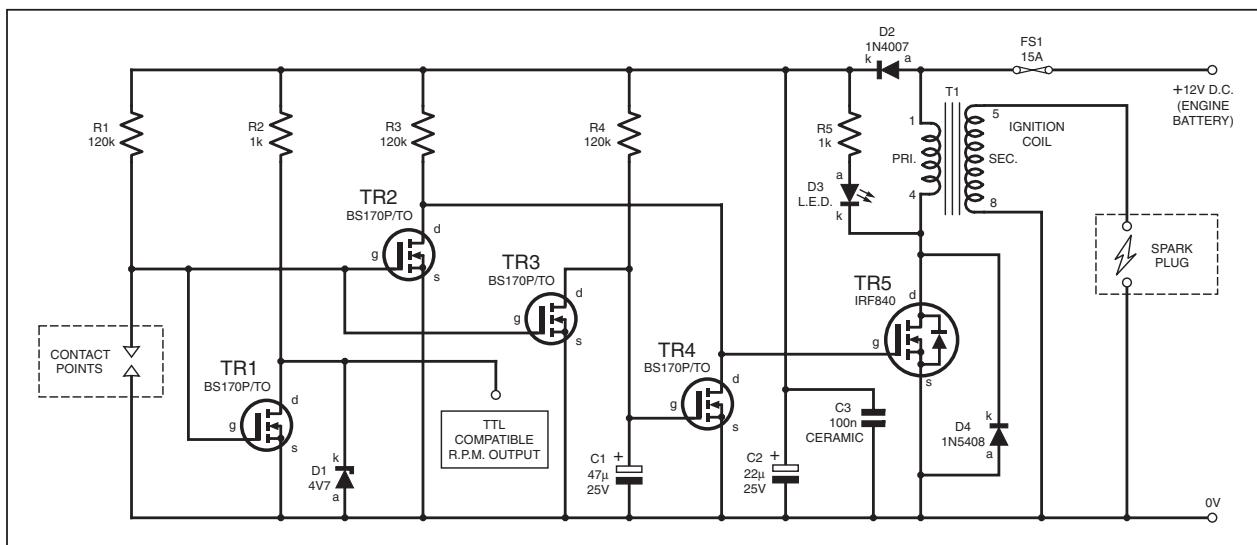

Fig. 1. Circuit diagram for a Single-Cylinder Ignition.

Reaction Timer

- Fast Flash

THE Reaction Timer of Fig.2 is an exercise in NAND gates. It uses three classic multivibrators which are made exclusively from NAND gates. The operation of the circuit is best described as follows.

Gates IC2c and IC2d form an astable multivibrator whose frequency of oscillation is governed by R4 and C3. The output of IC2d (pin 4) is fed to the clock input of IC1. This is a 4017 decoded decade counter which counts the input pulses via outputs Q0 to Q9, lighting up a different l.e.d. on each pulse it receives. After output Q9, the counter normally resets to Q0 and repeats the cycle. However, pin 11 is connected to pin 13 (inhibit/enable), via D2, which disables the counter and stops the cycle from repeating itself.

When the Reset switch (S2) is closed, a monostable multivibrator formed of IC2a and IC2b is enabled whose time constant is governed by C2 and R3, about 10 seconds with the values shown. The output from pin 11 is high during this cycle, which resets IC1 to Q0. The first l.e.d. D3 is on during this time, and it stays on until the monostable cycle is over.

The counter will then start counting the astable pulses, and all the remaining l.e.d.s will light rapidly in sequence. The object of the Reaction Timer is therefore to see how quickly the Stop button S1 can be pressed after the first l.e.d. goes out.

A bistable latch (flip-flop) is formed from IC3. When the Reset button is pushed, the output from pin 10 goes low and stays low. When the Stop button is pushed, pin 10 of

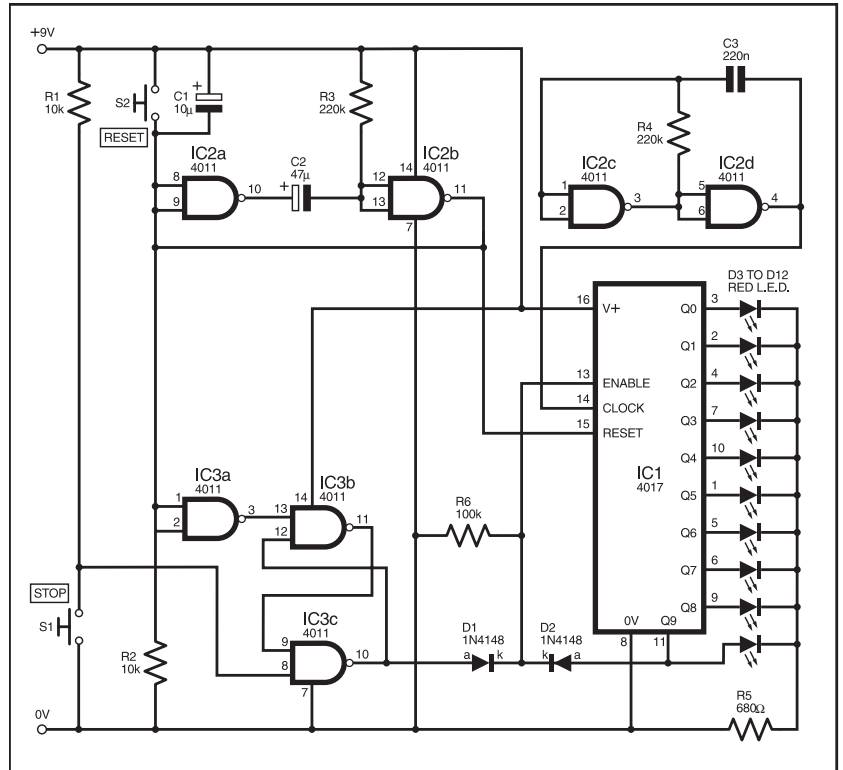

Fig.2. Circuit diagram for a simple l.e.d. Reaction Timer.

IC3 goes high and disables IC1 from counting. Diodes D1 and D2 form an OR gate to disable IC1 either by the Stop button or by l.e.d. D12 lighting up, whichever comes first.

Capacitor C1 turns the monostable on as soon as the circuit is powered up.

Martin Weighell,
Tiverton, Devon

**IT'S A GREAT WIND-UP ISSUE NEXT MONTH
- SO ORDER YOUR COPY NOW!**

★ WIND-UP TORCH II ★

PLUS: 200MHz FUNCTION GENERATOR
DRIVER ALERT

Annual subscription rates:

- 6 Months: UK £15.50, Overseas £18.50 (standard air service),
£27.50 (express airmail)
- 1 Year: UK £29.50, Overseas £35.50 (standard air service)
£53 (express airmail)
- 2 Years: UK £54.00, Overseas £66.00 (standard air service)
£101 (express airmail)

To: Everyday Practical Electronics,
Wimborne Publishing Ltd., 408 Wimborne Road East, Ferndown, Dorset
BH22 9ND

Tel: 01202 873872 Fax: 01202 874562

E-mail: subs@epemag.wimborne.co.uk

Order from our online shop at:

www.epemag.wimborne.co.uk/shopdoor.htm

Name

Address

Post code Tel.

If you do not wish to cut your issue, send a letter or copy of this form.



TAKE ADVANTAGE NOW!



SUBSCRIPTION ORDER FORM

I enclose payment of £
(cheque/PO in £ sterling only),
payable to Everyday Practical Electronics

My card number is:
Please print clearly, and check that you have the number correct

Signature

Card Security Code (The last 3 digits on or just under the signature strip)

Card Ex. Date Switch Issue No.

Subscriptions can only start with the next available issue.
For back numbers see the Back Issues page.

FLOWLOG

datalogging • control • electrical measurement

A NEW, LOW COST OSCILLOSCOPE, DATALOGGER AND CONTROL UNIT

£99

+VAT

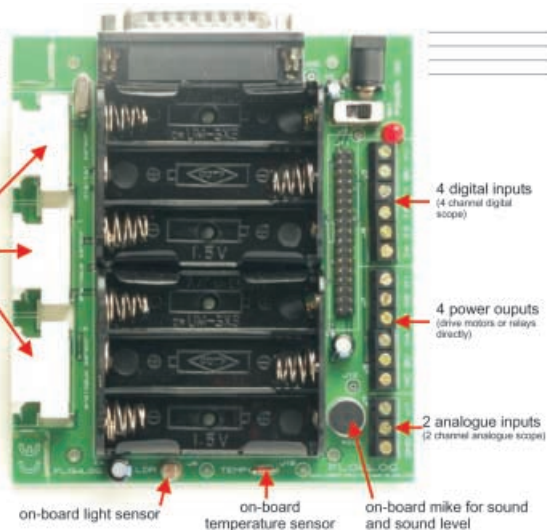

FREE SOFTWARE APPLICATIONS INCLUDE:

2 channel analogue scope

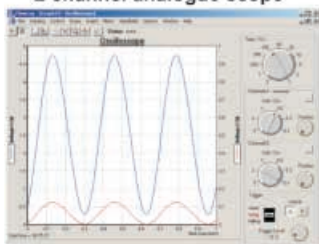

4 channel digital scope

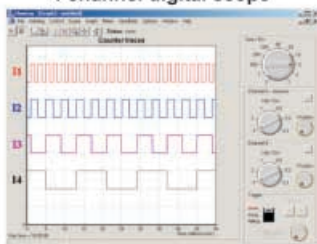

advanced datalogging software

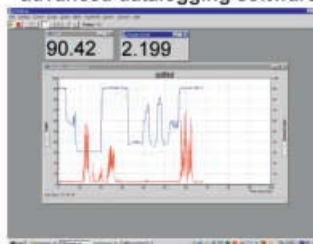

flexible control software



Flowlog is a new computer interface that provides datalogging, control and electrical measurement functions for use in science and electronics. Flowlog provides unrivalled value for money and performance. Please log onto our web site for full specification and description.

www.matrixmultimedia.co.uk
sales@matrixmultimedia.co.uk
 t. 0870 700 1831 f. 0870 700 1832



A COMPLETE RANGE OF INVERTERS

150W TO 2500W - 12V & 24V

A Complete range of regulated inverters to power 220V and 240V AC equipment via a car, lorry or boat battery. Due to their high performance (>90%) the inverters generate very little heat. The high stability of the output frequency (+/-1%) makes them equally suitable to power sensitive devices.

These inverters generate a modified sine wave, which are considerably superior to the square waves which are produced by most other inverters. Due to this superior feature they are capable of powering electrical equipment such as TV's, videos, desktop & notepad computers, microwave ovens, electrical lamps, pumps, battery chargers, etc.

Low Battery Alarm

The inverters give an audible warning signal when the battery voltage is lower than 10.5V (21V for the 24V version). The inverter automatically shuts off when the battery voltage drops below 10V (20V for the 24V version). Fuse protected input circuitry.

Order Code	Power	Voltage	Price
651.581	150W Continuous	12V	£36.39
651.578	150W Continuous	24V	£36.39
651.582	300W Continuous	12V	£50.64
651.585	300W Continuous	24V	£50.64
651.583	600W Continuous	12V	£101.59
651.593	600W Continuous	24V	£101.59
651.587	1000W Continuous	12V	£177.18
651.597	1000W Continuous	24V	£177.18
651.602	1500W Continuous	12V	£314.52
651.605	1500W Continuous	24V	£314.52
651.589	2500W Continuous	12V	£490.54
651.599	2500W Continuous	24V	£490.54

All prices are inclusive of V.A.T. Carriage £6.00 Per Order

Many uses include:- Fetes * Fairgrounds * Airshows * Picnics * Camping * Caravans * Boats * Carnivals * Field Research and * Amateur Radio field days * Powering Desktop & Notepad Computers.

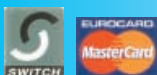

B.K. ELECTRONICS



UNIT 1, COMET WAY, SOUTHEND-ON-SEA, ESSEX. SS2 6TR
 TEL.: +44(0)1702-527572 FAX.: +44(0)1702-420243



ILLUSTRATION SHOWN IS 651.583 600W VERSION.

DELIVERY CHARGES ARE £6.00 PER ORDER. OFFICIAL ORDERS FROM SCHOOLS, COLLEGES, GOVT. BODIES, PLC'S ETC. PRICES ARE INCLUSIVE OF V.A.T. SALES COUNTER. VISA AND ACCESS ACCEPTED BY POST, PHONE OR FAX, OR EMAIL US AT SALES@BKELEC.COM ALTERNATIVELY SEND CHEQUE OR POSTAL ORDERS MADE PAYABLE TO BK ELECTRONICS.

For Full Specifications View our web site at:-
WWW.BKELEC.COM/INVERTERS.HTM

IN THE BAG

TERRY de VAUX-BALBIRNIE

Have you ever wondered how your car airbags work?

AIRBAGS have been fitted in up-market cars since the 80s. However, they have only appeared in volume production models in the UK since the mid-90s. It might therefore be thought that the idea of using an inflatable bag to protect the occupants of a vehicle in the event of an accident is a recent one. In fact, a patent was filed for "an inflatable crash-landing device" for aircraft in World War II.

CONTROVERSY

The idea of cushioning a person against the potentially fatal effects of a serious accident seems attractive. Even so, the use of airbags remains controversial. They have even killed some people.

Injuries have been caused to the neck and indirect damage due to inappropriate deployment (for example, in a minor collision) causing the driver to lose control at a critical time. Injuries can occur to children or small people in the front passenger seat due to the violence of the airbag striking them (on inflation it moves at around 140 miles per hour or over 200 metres per second).

Since the bag will be inflating when making contact with any exposed area of skin, the friction may cause burns. Although these might be painful and possibly require hospital treatment, they are considered to be a minor risk in what is, after all, a serious situation. There have also been reports of hearing problems resulting from the sudden increase in pressure as air is displaced when the bag inflates.

Even so, it is generally agreed that the use of airbags has resulted in fewer serious injuries compared with not using them. Research in the US has shown that the risk of dying from direct impact to the front of a car is reduced by more than 30 per cent. The trend among car manufacturers is to build on this by using multiple systems to provide passenger and side impact protection.

SOME PHYSICS

During a collision, rapid deceleration of the car occurs. Because the occupants are free to move, they appear to be "thrown forwards" (when, in fact, they just keep moving until restrained by a force). This is in accordance with Newton's First Law of Motion.

With no inbuilt form of protection, the restraining force would be provided by the reaction of the person's head striking the steering wheel, dashboard or windscreen. In severe accidents, he or she could even be ejected from the car.

The most important means of protection are the seat belts. These are therefore regarded as the *primary* restraint and any other system is considered to operate in conjunction with and not in place of them. An airbag is therefore regarded as the *Supplementary Restraint System* (many people have wondered what "SRS" as written on the outside of the airbag housing stands for). Those suffering injuries despite the airbag being deployed were often found not to have been wearing a seat belt or were wearing it incorrectly.

WHIPLASH

The disadvantage of the seat belt alone is that, in the event of a collision, the head continues to move forwards and this can cause injury both to itself and the neck. On stopping, the head tends to be



thrown back again which causes the particular type of injury known as *whiplash*.

An airbag increases the area of contact between the body and the means of restraint. This lowers the pressure and reduces injuries to the chest. Restraint from the airbag is provided through the elasticity of the gas inside it.

In a practical system, the bag inflates before the head has moved very far from its rest position then deflates. The whole process takes place in less than 120ms (milliseconds). If a car hits a fixed object at 30mph, there will be some 100ms before the head would otherwise strike the windscreen (the deceleration is not instantaneous because it is limited by the controlled crumpling of the car structure).

It would, therefore, take some 50ms for the head to make contact with the airbag mid-way between its rest position and the windscreen. Since it takes around 30ms for inflation to occur, the decision for deployment must therefore be made no later than 20ms after impact.

EARLY PROBLEMS

The main problems encountered in early systems were in providing sufficiently rapid inflation and finding reliable means of deployment. Using a cylinder of compressed air stored under the driver's seat was one early method.

Although this worked quickly enough, it was clumsy and difficult to control accurately and predictably especially with changes in temperature. Also, the gas cylinder occupied valuable space and

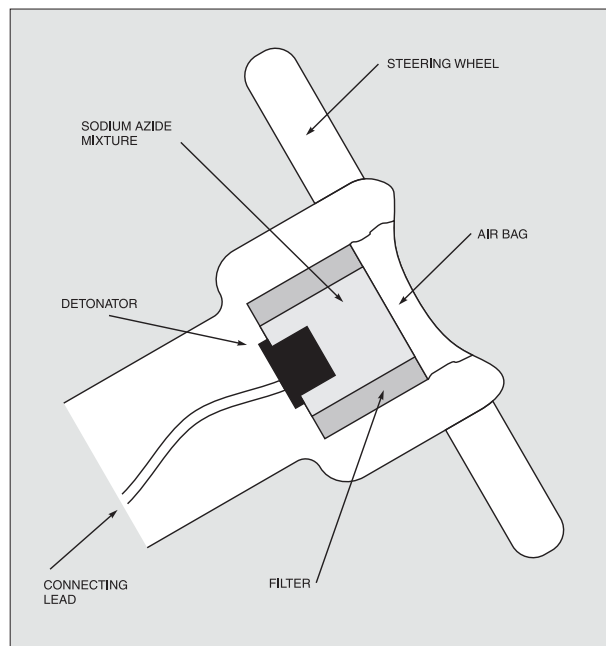

Fig.1. Simplified airbag operating system using a detonator (squib) and chemical reaction to inflate the bag housed in the steering column.

Some are directional so that they are sensitive only to a frontal collision. Others are multi-axis types. These consist of more than one unit in the same package so that they will respond to different directions and provide outputs accordingly. They may then deploy front and side-impact airbags independently.

PIEZOELECTRIC ACCELEROMETER

A piezoelectric accelerometer type of sensor exploits the piezoelectric effect whereby certain crystals (notably quartz and certain ceramic materials) produce a voltage pulse between a pair of electrodes attached to opposite faces when the crystal is stressed. This is the principle on which “crystal” microphones and record player pickups work.

A wafer of piezo-electric material having a small mass attached to it is shown in Fig.4. Under deceleration, the material will be compressed and a voltage output obtained between the electrodes.

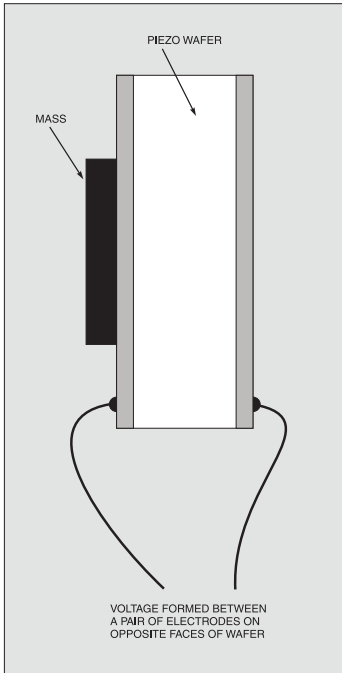

Fig.4. Piezoelectric accelerometer wafer.

STRAIN-GAUGE

A strain-gauge accelerometer works by measuring the change in resistance of a piece of fine wire when it is stretched. One form has a cantilever beam (a small flexible bar fixed at one end) with a mass attached near the free end (see Fig.5).

On acceleration or deceleration the beam will bend one way or the other. This bending is translated into a variable voltage by the change in resistance of a small resistive element attached to one side of it (a strain-gauge).

The strain-gauge consists of a zigzag of very fine wire which, in practice, will be laser-etched on an insulating substrate. This provides a long piece of thin wire in the small size of the sensor.

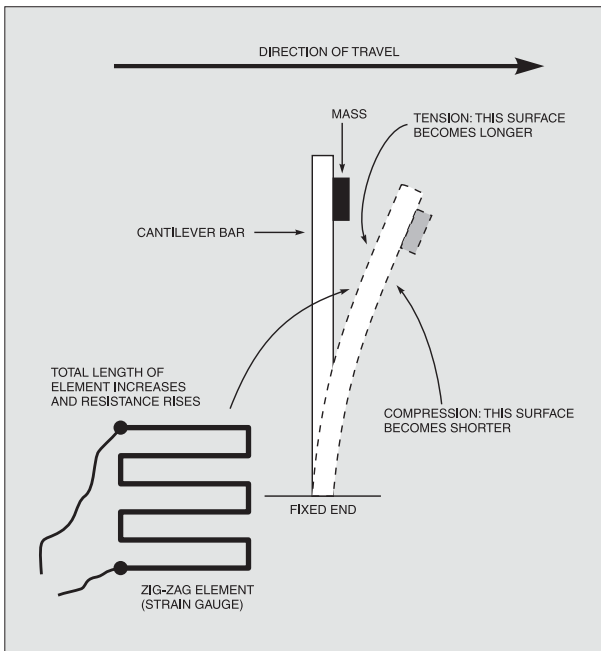
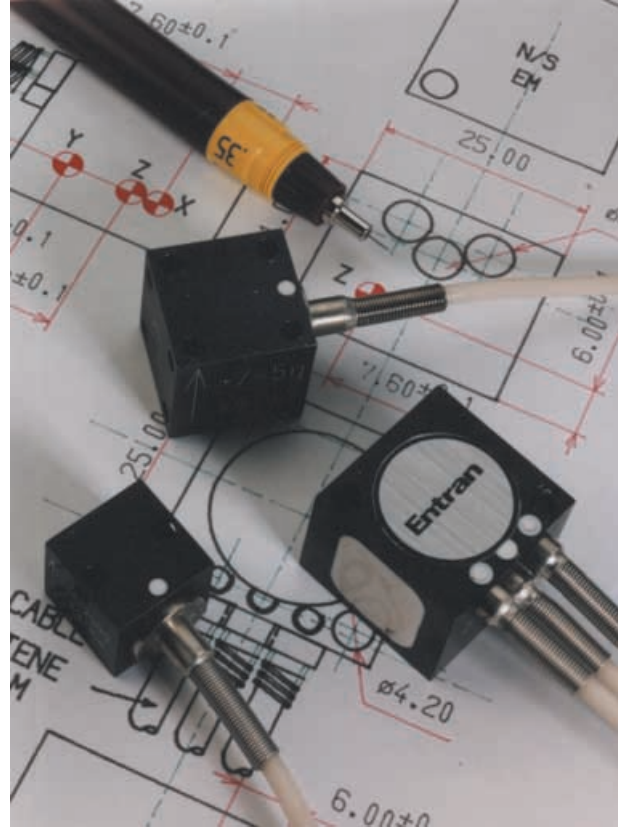

Fig.5. Principle of operation of a strain-gauge accelerometer. It works by measuring the change in resistance of a fine wire when it is “stretched” or strained.



Entran EGCS single-axis and multi-axis accelerometers as used in automotive airbag systems. Courtesy Entran Sensors & Electronics.

When the beam bends, the face in tension becomes slightly longer and the one under compression, shorter. If the strain-gauge is attached to the face in tension, the wire will become longer and its resistance increase. The Entran EGCS family of single and dual-axis accelerometers shown in the photograph above are of the cantilever beam and strain-gauge type.

WHEATSTONE BRIDGE

A Wheatstone bridge circuit (see Fig.6) may be used to detect the small change in resistance of a strain-gauge. Fixed resistors, R2 to R4, form three “arms” of the bridge. The resistive element forms the arm R1.

If all resistors (including the strain-gauge while at rest) have equal values (R ohms), the voltage at point X will equal that at point Y. This is because potential dividers are formed between R1 and R2 on one hand and R3 and R4 on the other. Both these are connected across the supply.

The voltage at points X and Y will both be one-half of the supply voltage so there will be no voltage difference between them. The bridge is said to be “balanced”.

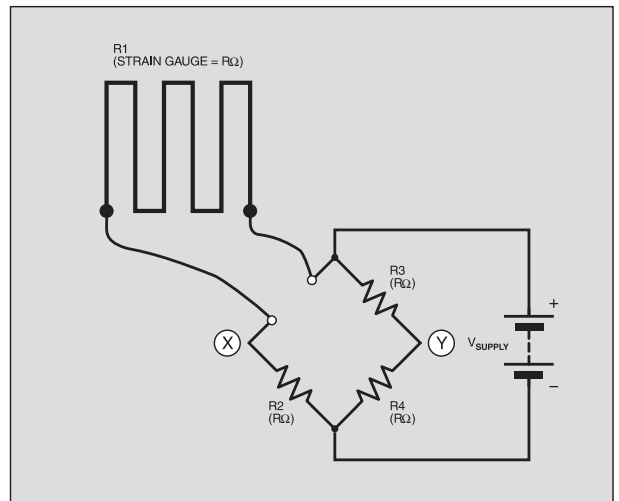

Fig.6. A Wheatstone bridge circuit may be used to detect any small change in resistance of a strain-gauge.

If R1 increases its resistance, it will become greater than R2. The voltage at point X will now fall below one-half of the supply voltage. However, the voltage at point Y will remain unchanged so that a voltage difference will exist between them.

An op.amp comparator connected between points X and Y will detect the voltage difference and send a signal to the control system. If all the resistors and the operational amplifier are fabricated on the same chip, any effect due to temperature changes can be cancelled out.

CAPACITIVE ACCELEROMETER

A capacitor is basically two conducting plates separated by an insulator. Its value depends on the area of the plates, their distance apart and the nature of the insulating medium (the dielectric).

There are many different types of capacitive sensor. In one design, the plates are in the form of semi-overlapping "combs" (see Fig.7). The lower unit is fixed but the upper one is loaded with a mass and able to bend at one end. Under deceleration, the degree of overlap will vary giving the equivalent of a change in the area of the plates.

The resulting variation in capacitance may be measured using a capacitance bridge. This is a type of Wheatstone bridge but uses a.c. (alternating current). Another method is to use the value of the capacitor to determine the frequency of a square-wave oscillator. The output will then be in the form of a pulse train having a frequency dependent on the deceleration.

The latest approach by *Analog Devices* is integrated MEMS (Micro Electrical Mechanical Systems) technology. In this, microscopic moving parts and control circuits are fabricated on a single integrated circuit. The advantage is that the same established i.c. techniques are used for the entire process. Thus a "spring" may be fabricated to suspend a miniature capacitor plate between a pair of fixed ones.

Deceleration will be translated into an increase in capacitance between the moveable plate and one fixed plate and a reduction with the other one. The change in relative capacitance may then be measured using a bridge.

The *Analog Devices* ADXL series of MEMS accelerometers provide two-axis sensing (see photograph). Note that this device has pins on the underside for p.c.b. mounting.

In a modern car, the accelerometer assembly might be separate or integrated with the airbag unit itself. The system may also incorporate a capacitive reserve power supply so that the airbag may be "fired" even if the battery supply fails.

LATEST RESEARCH

The aim of research today is to design a control system that will make a better judgement on whether or not to deploy an airbag and to deploy it more safely. The various car manufacturers are very secretive about their latest lines of research. This is because being first to introduce a "safer" system will give them the edge in selling their models.

In a sophisticated system, various types of sensor may be fitted inside the passenger compartment. These feed additional data into the control unit regarding the number of occupants, their mass, position and whether or not they are wearing seat belts. In one model, there is a seat weight sensor that disables the airbag if 30kg or less present – that is, if it is unoccupied or has a child in it.

Airbags themselves are also becoming more "intelligent". Some are able to inflate at different rates. This may be done by employing one "fast" and one "slow" gas generator. Either the slow alone, the fast alone or both may then be "fired".

Some companies are developing systems to provide a continuously-variable inflation rate and final pressure. These take account of the information being provided by various additional sensors of the type mentioned above.

All this would be integrated with new and "smarter" seat belts that tighten progressively at the onset of a crash. They could also relax slightly at the point where injury might occur or even inflate to cushion vulnerable points of contact with the body.

DATA LOG

The investigation of an accident may be made more scientific by the airbag controller providing data after it. Such

information would be extremely useful to police and insurance assessors.

In one system, information regarding the vehicle speed, throttle position and use of the brakes is recorded over each five-second period. If nothing particular happens, it is overwritten. If the airbag is deployed, or *near-deployed*, a signal is given to store this data which may be recovered later.

EDUCATION, EDUCATION, EDUCATION

Critics argue that airbag systems are becoming much too complicated and might even increase the chance of inappropriate deployment. Many people wonder whether education is not just as important as advancing the technology.

For example, why detect whether or not seat belts are being used when they should be worn anyway? A simple buzzer could be used as a reminder if this had been forgotten. Should not children always sit in the rear seats?

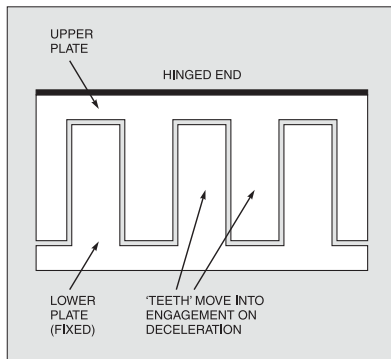

Fig.7. A capacitive accelerometer.



Right: An accelerometer using micro electrical mechanical systems (MEMS) technology from Analog Devices.

Some of the most interesting research concerns the ability of a system to detect the likelihood of an accident occurring seconds *before* it happens by examining the traffic situation using radar sensors and/or video cameras. The first defence could then be for the system to take over control and attempt to avoid the accident by steering and braking. Such systems seem to be a long way off on account of the complexity of the problem. Taking over control inappropriately would, of course, be extremely dangerous! □

www.epemag.com

Get your magazine "instantly" anywhere in the world – buy from the web.

TAKE A LOOK, A FREE ISSUE IS AVAILABLE

A one year subscription (12 issues) costs just \$10.99 (US)

SURFING THE INTERNET

NET WORK

ALAN WINSTANLEY

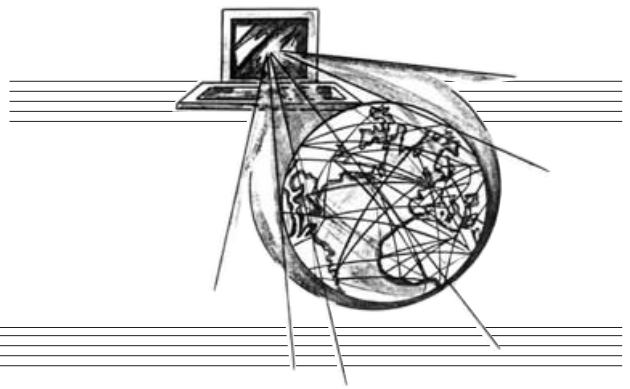

The Last Keyword in Sales

WITH many millions of web sites now connected to the Internet, the sheer scale of information available often makes it difficult for users to know where to start, a fact that search engines and portal sites recognised long ago. As an imperative, the writer has the Google Toolbar installed in his web browser, which means that web and Usenet searches are not far away. Other popular engines include Lycos, Ask Jeeves and Alta Vista; so-called "directory" sites such as Yahoo and the largest of them all, The Open Directory (www.dmoz.org), are different because human editors screen and approve the web sites they contain, and they attempt to focus on a particular category.

Search engines are useful, but they are not the last word in Internet searching. The industry is fast learning how to make money from our quest for sorting out mountains of information published on the Internet: they can charge companies to be listed in the engine. Furthermore, a whole industry of search-engine positioning (SEP) or search-engine optimisation (SEO) has sprung up, to help ensure that commercial web sites are guaranteed to be displayed high up in search engine results when users search for a certain keyword or phrase. Being listed high in the results means more traffic for the company, which translates into more business for them.

One UK company spends nearly £25,000 per month on "pay per click" (PPC) marketing, a quite complex system in which web site owners "bid" for clicks from search engines. The higher the bid for a keyword or phrase (e.g. "car loan"), the higher up in the results their web site will appear. Every user that clicks through to the web site costs the web site owner some hard cash. Bids range from a few pence up to £10 or more, but this can prove to be cheap when compared with press or TV advertising. Overture (www.overture.com), formerly known as GoTo.com, is a prime example of a PPC marketing company.

Google operates a similar system, which is seen as "sponsored links" over to the right-hand side of Google search results. These are part of Google's AdWords service. The search results highlighted across the top of the page are using Google's Premium Sponsorship service, and they are all URL's jostling for your attention and earning those prized "click-thrus". Because Google separates them out from the core of the search results, users know that

they are looking at a paid-for search engine placement. It can be harder to discriminate on some other sites.

Favourite Sites

Search engines are a key aspect of hunting down information on the Internet, but problems can arise when searching for, say, a particular software utility program. Trawling through the search engines can be a tedious job, and there is no guarantee that they will turn up trumps anyway, given that companies can skew the top search engine results in favour of their own products.

Experienced Internet users often start out by checking their own bookmarked favourite sites. (The freeware DzSoft Favourites search toolbar from www.dzsoft.com is a useful way of finding forgotten URL's by searching for a keyword.) Thankfully there are a number of specialist web sites related to software, including the excellent site MyWebAttack (www.mywebattack.com) which is a must-see for all Windows users.



The excellent MyWebAttack web site is an essential source of software for all Windows users.

MyWebAttack is a true goldmine of Windows shareware, freeware, "rare finds" or discontinued but useful software, and probably has enough to keep even the most ardent download enthusiast busy for weeks. Software is divided into categories and there are also small reviews, ratings and screenshots. It is a supremely useful resource, and has even got the author off the hook with the occasional missing dll file (especially useful when recently trying to install some commercial software onto a customer's rather decrepit PC).

Less stylish than MyWebAttack, but covering a wider range of platforms, is the shareware/freeware site www.download.com, which often produces long lists of matches when searching for a particular program, upgrade, patch or utility. These can take an eternity to trawl through, but the site has nevertheless turned up trumps on occasion. Both sites are worth bookmarking.

In coming months I aim to cover a number of topics written with the novice or average ability Internet user in mind. Next month, I will take a look at how E-bay works, and will show you how the world's most popular online auction can be a handy little money-spinner! If you have a particular topic that you think would form a useful *Net Work* article, please email your suggestion to alan@epemag.demon.co.uk.

Finally this month, regular users of our web site will know that it has been online in its present form for many years (since May 1996, in actual fact), and that a makeover is long overdue. The redesign is now at an advanced stage, and work is in progress on the web site content. New features plus all the old favourites will still be there in the new site, especially our simple-to-use password-free *Chat Zone* message board, and there will be new opportunities for advertisers as well. The ever-popular *Net Work* A-Z listing of web sites is also being revamped to make it more usable. Watch this space!

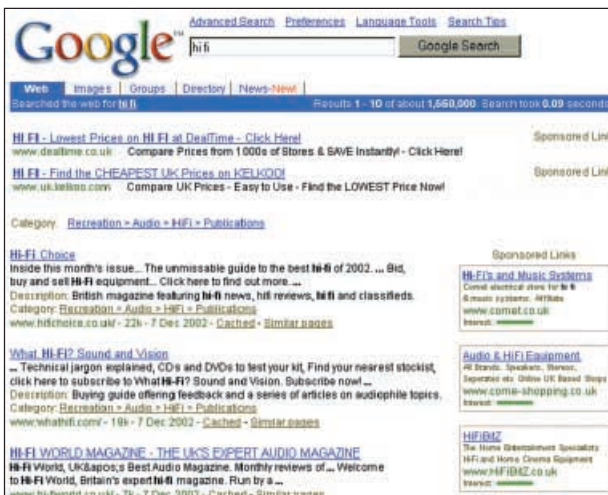

A Google search for "hi fi" shows two Premium Sponsorship web sites at the top, plus a number of paid-for Adword sites down the right hand side.

We can supply back issues of *EPE* by post, most issues from the past three years are available. An *EPE* index for the last five years is also available from www.epemag.wimborne.co.uk or see order form below. Alternatively, indexes are published in the December issue for that year. Where we are unable to provide a back issue a photocopy of any *one article* (or *one part* of a series) can be purchased for the same price. Issues from Nov. 98 are available on CD-ROM – see next page – and issues from the last six months are also available to download from www.epemag.com.

DID YOU MISS THESE?

OCT '01 Photocopies only

PROJECTS • PIC Toolkit MK3 • Camcorder Power Supply • 2-Valve SW Receiver • Perpetual Projects 4 – Gate Sentinel – Bird Scarer – In-Out Register.
FEATURES • Traffic Control • Ingenuity Unlimited • New Technology Update • Circuit Surgery • Interface • Net Work – The Internet Page • *Free* 2 CD-ROMs – Microchip 2001 Tech Library.

NOV '01

PROJECTS • Capacitance Meter • Pitch Switch • Lights Needed Alert • Teach-In 2002 Power Supply.
FEATURES • Teach-In 2002 – Part 1 • Practically Speaking • Circuit Surgery • New Technology Update • Ingenuity Unlimited • Net Work – The Internet Page • *Free* 16-page Supplement – PIC Toolkit TK3 For Windows.

DEC '01

PROJECTS • Ghost Buster • PIC Polywhatsit • Twinkling Lights • Mains Failure Alarm.
FEATURES • Teach-In 2002 – Part 2 • Marconi – The Father of Radio • Interface • Ingenuity Unlimited • Circuit Surgery • New Technology Update • Net Work – The Internet Page • 2001 Annual Index.

JAN '02

PROJECTS • PIC Magick Musick • Time Delay Touch Switch • Versatile Bench Power Supply • Forever Flasher.
FEATURES • Teach-In 2002 – Part 3 • Practically Speaking • Ingenuity Unlimited • New Technology Update • Circuit Surgery • Net Work – The Internet Page.

FEB '02

PROJECTS • PIC Spectrum Analyser • Guitar Practice Amp • HT Power Supply • Versatile Current Monitor.
FEATURES • Teach-In 2002 – Part 4 • Ingenuity Unlimited • Russian Space Shuttle Revisited • Circuit Surgery • Interface • New Technology Update • Net Work – The Internet Page.



MAR '02

PROJECTS • MK484 Shortwave Radio • PIC Virus Zapper • RH Meter • PIC Mini-Enigma.
FEATURES • Teach-In 2002 – Part 5 • Ingenuity Unlimited • Programming PIC Interrupts-1 • Circuit Surgery • Practically Speaking • New Technology Update • Net Work – The Internet Page.

APR '02

PROJECTS • Electric Guitar Tuner • PIC Controlled Intruder Alarm • Solar Charge and Go • Manual Stepper Motor Controller.
FEATURES • Teach-In 2002 – Part 6 • Interface • Programming PIC Interrupts-2 • Circuit Surgery • Ingenuity Unlimited • New Technology Update • Net Work – The Internet Page • *FREE* Giant Op.Amp Data Chart.

MAY '02

PROJECTS • PIC Big-Digit Display • Simple Audio Circuits – 1 • Freezer Alarm • Washing Ready Indicator.
FEATURES • Teach-In 2002 – Part 7 • Ingenuity Unlimited • Practically Speaking • New Technology Update • Circuit Surgery • Net Work – The Internet Page.

JUNE '02

PROJECTS • Biopic Heartbeat Monitor • Frequency Standard Generator • Simple Audio Circuits – 2 • World Lamp.
FEATURES • Teach-In 2002 – Part 8 • Interface • New Technology Update • Circuit Surgery • Ingenuity Unlimited • Net Work – The Internet Page.



JULY '02

PROJECTS • EPE StyloPIC • Infra-Red Autoswitch • Simple Audio Circuits – 3 • Rotary Combination Lock.
FEATURES • Teach-In 2002 – Part 9 • Practically Speaking • Using The PIC's PCLATH Command • Ingenuity Unlimited • Circuit Surgery • New Technology Update • Net Work – The Internet Page.

AUG '02

PROJECTS • PIC World Clock • Pickpocket Alarm • Big-Ears Buggy • Simple Audio Circuits – 4.
FEATURES • Teach-In 2002 – Part 10 • Using Square Roots with PICs • Ingenuity Unlimited • Evolutionary Electronics • Interface • Circuit Surgery • Net Work – The Internet Page.

SEPT '02

PROJECTS • Freebird Glider Control • Portable Telephone Tester • EPE Morse Code Reader • Vinyl to CD Pre-amplifier.
FEATURES • Circuit Surgery • New Technology Update • Practically Speaking • Net Work • Flowcode for PICmicro • Logic Gate Inverter Oscillators • Net Work – The Internet Page.

OCT '02 Photocopies only

PROJECTS • *EPE* Bounty Treasure Hunter • IC Tester • Headset Communicator • PIC-Pocket Battleships.
FEATURES • Circuit Surgery • New Technology Update • Logic Gate Inverter Oscillators – 2 • Interface • Network – The Internet Page • Using TK3 With Windows XP and 2000.

NOV '02

PROJECTS • *EPE* Hybrid Computer – 1 • Tuning Fork and Metronome • Transient Tracker • PICAXE Projects-1 (Egg Timer – Dice Machine – Quiz Game Monitor).
FEATURES • Practically Speaking • Ingenuity Unlimited • Circuit Surgery • New Technology Update • Net Work – The Internet Page.

DEC '02

PROJECTS • Versatile PIC Flasher • *EPE* Hybrid Computer – 2 • Door Defender • PICAXE Projects – 2 (Temperature Sensor – Voltage Sensor – VU Indicator).
FEATURES • Electronic Paper • Alternative Uses for Transistors • Interface • Circuit Surgery • New Technology Update • Ingenuity Unlimited • Net Work – The Internet Page • 2002 Annual Index.



JAN '03

PROJECTS • *EPE* Minder • F.M. Frequency Surfer • Wind Speed Meter • PICAXE Projects-3 (Chaser Lights).
FEATURES • Who Really Invented The Transistor • TechnoTalk • Circuit Surgery • Practically Speaking • New Technology Update • Computer GOTOs • Ingenuity Unlimited • Net Work – The Internet Page.

BACK ISSUES ONLY £3.50 each inc. UK p&p.

Overseas prices £4 each surface mail, £5.50 each airmail.

We can also supply issues from earlier years: 1998 (except Jan. to May, July, Nov., Dec.), 1999 (except Dec.), 2000 (except Feb.), 2001 (except May, Sept., Oct.), 2002 (except Oct.) Where we do not have an issue a photocopy of any *one article* or *one part* of a series can be provided at the same price.

ORDER FORM – BACK ISSUES – PHOTOCOPIES – INDEXES

- Send back issues dated
- Send photocopies of (article title and issue date)
- Send copies of last five years indexes (£3.50 for five inc. p&p – Overseas £4 surface, £5.50 airmail)

Name

Address

.....Tel:

I enclose cheque/P.O./bank draft to the value of £

Please charge my Visa/Mastercard/Amex/Diners Club/Switch £ Switch Issue No.

Card No.

Card Expiry Date Card Security Code (The last 3 digits on or just under the signature strip)

SEND TO: **Everyday Practical Electronics, Wimborne Publishing Ltd., 408 Wimborne Road East, Ferndown, Dorset BH22 9ND.**

Tel: 01202 873872. Fax: 01202 874562.

E-mail: orders@epemag.wimborne.co.uk On-line Shop: www.epemag.wimborne.co.uk/shopdoor.htm

Payments must be in £ sterling – cheque or bank draft drawn on a UK bank. Normally supplied within seven days of receipt of order.

Send a copy of this form, or order by letter if you do not wish to cut your issue.

M02/03

STORE YOUR BACK ISSUES ON MINI CD-ROMS



**VOL 7
NOW AVAILABLE**

**ONLY
£14.45** each
including VAT
and p&p

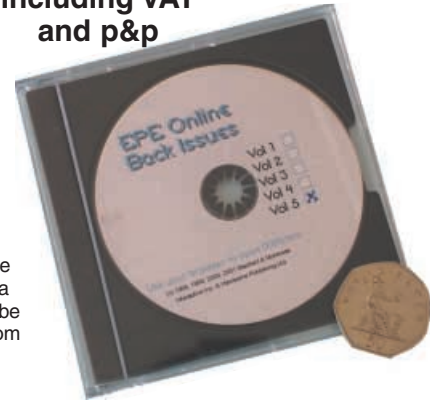

A great way to buy *EPE* Back Issues – our mini CD-ROMs contain back issues from our *EPE Online* website plus bonus articles, all the relevant PIC software and web links. Note: no free gifts are included. All this for just £14.45 each including postage and packing.

VOL 1 CONTENTS

BACK ISSUES – November 1998 to June 1999 (all the projects, features, news, IUs etc. from all eight issues). Note: No advertisements are included. **PIC PROJECT CODES** – All the available codes for the PIC based projects published in these issues.

VOL 2 CONTENTS

BACK ISSUES – July 1999 to December 1999 (all the projects, features, news, IUs, etc. from all six issues). Note: No advertisements are included. **PIC PROJECT CODES** – All the available codes for the PIC-based projects published in these issues.

VOL 3 CONTENTS

BACK ISSUES – January 2000 to June 2000 (all the projects, features, news, IUs, etc. from all six issues). **PIC PROJECT CODES** – All the available codes for the PIC-based projects published in these issues.

VOL 4 CONTENTS

BACK ISSUES – July 2000 to Dec. 2000 (all the projects, features, news, IUs etc. from all six issues). **PROJECT CODES** – All the available codes for the programmable projects in these issues.

VOL 5 CONTENTS

BACK ISSUES – January 2001 to June 2001 (all the projects, features, news, IUs etc. from all six issues). **PROJECT CODES** – All the available codes for the programmable projects in these issues, including those for *Interface*.

VOL 6 CONTENTS

BACK ISSUES – July 2001 to December 2001 (all the projects, features, news, IUs etc. from all six issues). **PROJECT CODES** – All the available codes for the programmable projects in these issues, including those for *Interface*.

VOL 7 CONTENTS

BACK ISSUES – Jan 2002 to June 2002 (all the projects, features, news, IUs etc. from all six issues). **PROJECT CODES** – All the available codes for the programmable projects in these issues, including those for *Interface*.

EXTRA ARTICLES – ON ALL VOLUMES

BASIC SOLDERING GUIDE – Alan Winstanley's internationally acclaimed fully illustrated guide. **UNDERSTANDING PASSIVE COMPONENTS** – Introduction to the basic principles of passive components. **HOW TO USE INTELLIGENT L.C.D.s**, By Julian Ilett – An utterly practical guide to interfacing and programming intelligent liquid crystal display modules. **PhyzyB COMPUTERS BONUS ARTICLE 1** – Signed and Unsigned Binary Numbers. By Clive "Max" Maxfield and Alvin Brown. **PhyzyB COMPUTERS BONUS ARTICLE 2** – Creating an Event Counter. By Clive "Max" Maxfield and Alvin Brown. **INTERGRAPH COMPUTER SYSTEMS 3D GRAPHICS** – A chapter from Intergraph's book that explains computer graphics technology in an interesting and understandable way with full colour graphics.

EXTRA ARTICLE ON VOL 1 & 2. THE LIFE & WORKS OF KONRAD ZUSE – a brilliant pioneer in the evolution of computers. A bonus article on his life and work written by his eldest son, including many previously unpublished photographs.

NOTE: These mini CD-ROMs are suitable for use on any PC with a CD-ROM drive. They require Adobe Acrobat Reader (available free from the Internet – www.adobe.com/acrobat)

Order on-line from
www.epemag.wimborne.co.uk/shopdoor.htm
or www.epemag.com (USA \$ prices)
or by phone, Fax, E-mail or Post

BACK ISSUES MINI CD-ROM ORDER FORM

Please send me (quantity) BACK ISSUES CD-ROM VOL 1
Please send me (quantity) BACK ISSUES CD-ROM VOL 2
Please send me (quantity) BACK ISSUES CD-ROM VOL 3
Please send me (quantity) BACK ISSUES CD-ROM VOL 4
Please send me (quantity) BACK ISSUES CD-ROM VOL 5
Please send me (quantity) BACK ISSUES CD-ROM VOL 6
Please send me (quantity) BACK ISSUES CD-ROM VOL 7
Price £14.45 each – includes postage to anywhere in the world.

Name

Address

.....

..... Post Code

I enclose cheque/P.O./bank draft to the value of £

Please charge my Visa/Mastercard/Amex/Diners Club/Switch

£

Card No.

Card Security Code (The last 3 digits on or just under the signature strip)

Expiry Date Switch Issue No.

SEND TO: **Everyday Practical Electronics,
Wimborne Publishing Ltd.,**

408 Wimborne Road East, Ferndown, Dorset BH22 9ND.

Tel: 01202 873872. Fax: 01202 874562.

E-mail: orders@epemag.wimborne.co.uk

Payments must be by card or in £ Sterling – cheque or bank draft drawn on a UK bank.

Normally supplied within seven days of receipt of order.

Send a copy of this form, or order by letter if you do not wish to cut your issue.

READOUT

E-mail: editorial@epemag.wimborne.co.uk

John Becker addresses some of the general points readers have raised. Have you anything interesting to say? Drop us a line!

All letters quoted here have previously been replied to directly.

WIN A DIGITAL MULTIMETER

A 3½ digit pocket-sized I.c.d. multimeter which measures a.c. and d.c. voltage, d.c. current and resistance. It can also test diodes and bipolar transistors.

Every month we will give a Digital Multimeter to the author of the best Readout letter.



★ LETTER OF THE MONTH ★

TENS INTO EIGHT DOES GO!

Dear EPE,

Thanks for the great articles and projects – it can't be easy coming up with goods month after month! *EPE* really is a godsend for chaps like me, I design and make mine detectors so electronics is only a part of my week, and I often haven't got enough hours to study a component or part in any depth like you do. And most of the time a simple explanation and a quick guide is all I need. Many thanks for the countless hours I have saved by having *EPE* handy!

Please give my most kindest regards to Andy Flind. For my final year project at university, I designed an 8-channel acupuncture machine using one of his TENS designs but using a PIC to get different waveforms and timings. I got a B+ if I remember correctly, not bad considering I couldn't show it working as I had broken the I.c.d. the night before.

I wouldn't have thought of it if it wasn't for that article, and I found acupuncture and

electro-acupuncture to be a fascinating subject. I have no idea why people should doubt the legitimacy of the technique. We have a fair amount of electric circuitry running through us, and so whacking some electricity into it is going to have some effect, surely? Just a matter of trial and error to find what works.

Darren G., via email

Thank you Darren – in fact we have lots of good material constantly coming in and the problem is more one of what do we leave out of an issue rather than what have we got to put in!

Andy's TENS designs of '94 and '97 proved to be very popular. He too is well into PICs now and in due course he will probably produce a PIC-controlled TENS design. There seems to be no doubt that such devices do aid pain relief. They are readily available commercially through such well-respected retail outlets as Boots.

OBSTACLE DETECTION

Dear EPE,

I now live in America, after moving here nearly three years ago. I have *EPE* sent out to me every month and recently purchased a back issue for a project from 1992.

Have you done any projects for an obstacle detection warning type system, such as something obstructing a door closing or something similar to prevent children being caught in a tailgate or side door of a van. We had a baby a few months ago, and want to install some kind of warning system on my van tailgate and/or sliding door before she gets to the age of crawling "unseen" into dangerous places. Maybe the system could even be adapted for domestic applications.

Jim Todd, Marshall, USA, via email

No, Jim, it's not something that we recall doing. Why not ask readers via our Chat Zone if they know of anything? They can be a mine of information on occasions! Your letter might also produce results, in which case I'll let you know by email.

POWERFUL REQUEST

Dear EPE,

I am a student doing S4 level at Mangosuthu Technikon intending to do a Level 3 design project (heavy current). Please can you send me an email illustrating the 200 Watts Mini Inverter or the PIC Dual Power Supply, or anything you have on heavy current designs.

S.T.F. Zwane, via email

So sorry to disappoint you but we cannot do as you ask – copies of such published articles are chargeable and can only be purchased for delivery by normal mail, or electronically via our web site facilities. They can be ordered from our Online shop at www.epemag.wimborne.co.uk/shopdoor.htm, or from the Editorial office, prices as quoted on site and in current issues.

MIDI TO USB

Dear EPE,

With reference to G. S. Chatley's letter in *Readout* of Aug '02, I also await a PIC interface from MIDI to USB. I would like to connect the MIDI output from my electronic piano keyboard to my computer.

This is to encourage you to bring the project along for publication. Thanks for your work and your magazine. I came to *EPE* via the *ETI* route!

Norman Quinn, via email

Thanks for the suggestion Norman – It's the PIC to USB interface we're waiting for before we can move on. All in good time we hope!

LINEAR BOUNTY

Dear EPE,

I am making the *EPE* Bounty Treasure Hunter (Oct '02) as a project for college. I would like to know if the potentiometers VR1 and VR2 are log or linear.

Kevin Brock, via email

In our circuit diagrams and parts lists, Kevin, pots are always linear unless marked as log.

VINTAGE SAFETY

Dear EPE,

I've recently read Paul Stenning's very interesting supplement on *Collecting and Restoring Vintage Radios* (Oct '02) and agree whole heartily with the recommendations on safety. However, for test purposes the standard RCCB, which trips at 30mA, is not sensitive enough to provide adequate protection. It is normal practice in industry to use an RCCB that trips at 10mA. Whilst these are not available at DIY stores, they are obtainable from professional sources. They cost more but how much is your life worth?

Peter Mitchell, via email

More than the cost of a good RCCB! Thanks Peter.

LIFE, THE UNIVERSE, MORSE AND TK3

Dear EPE,

I have the Magenta version of your *Toolkit TK3* programmer p.c.b. (Nov '01) plus your *PIC Tutorial*. The only "problem" is the Magenta version does not have all the I.e.d.s and switches referred to in your *Tutorial*. Your *Toolkit* software is excellent and easy to use.

Having recently completed the *Morse Code Reader* (Sept '02), I have some feedback for you. The Morse code numeral "3" is not being decoded, it comes out as a "3*!". All other characters seem ok.

I find that the audio interface/detector is much too basic and needs a band-pass filter centred on about 800Hz with a bandwidth of say 100Hz, easily done with a couple of op.amps and a Schmitt trigger device.

The PIC software also needs a noise reduction routine, as a small burst of noise throws the decoder out for some time before it recovers. It would be good to be able lock the decoder when one has good copy, so if conditions change good copy resumes immediately when the signal comes back up from the noise. What changes would be required to "lock" the decoder so that it is not upset by a burst of noise affecting its internal rate assessment routine?

It was good to see a standalone CW decoder article, and one that does not need a PC!

Colin Manklow, via email

As I say in the TK3 text (glad you like TK3!), the Tutorial text is not intended for direct use by TK3. To use the Tutorial fully you really need its own board (via our Online shop). The object of including the Tutorial text with TK3 (I assume that is what you are referring to) is for people to simply read about the way I've done various things. It is only an edited version of the original Tutorial text (March to May '98) and does not include schematics or demo program listings.

Regarding a Morse "lock" – pass! It could be complicated, although you might get away with putting in another switch and adding some lines to tell the unit to only change rate when the switch is in a particular position. Thank you for the filter suggestion – for Morse Mk2 perhaps – should I ever!

The "3" problem was corrected very early on and its amended software put on our Disk 5 and ftp site.

PICS AND KEYBOARDS

Dear EPE,

I have been subscribing to *EPE* since March '02, and I'm very interested in the articles on PIC projects. Have you published an article about PC keyboard decoding using a PIC16F84 (to get the ASCII code from the keyboard when a key is pressed)?

Paul Hart, via email

No, Paul, we haven't. The nearest we've come to it is my Using PICs and Keypads of Jan '01. The keypads referred to are the matrixed pushbutton types. Try asking readers via our Chat Zone if they know of any source of info.

Would other readers like us to consider publishing an article? I might be interested to design a PIC circuit for this if enough people would like one.

TK3 AND 2000/XP, PLUS IDEAS

Dear EPE,

Just a couple of comments and additions to Mark Jones' very useful article *Using TK3 with Windows XP and 2000* in the Oct '02 issue:

First, it's not quite correct to say that only Windows NT, 2000 and XP run the processor in protected mode. All Windows OSs, from Windows 3.1 onwards, and the various DOS extenders that preceded them, have used protected mode. In real mode, only 1Mb of memory is addressable, so any PC that has used more memory than that must have run in protected mode.

What NT, 2000 and XP do (and 95, 98, ME do not) is to exploit additional protection features in the CPUs that allow the OS to put restrictions on the computer resources that ordinary applications programs can access. This should make these systems more secure and less prone to crashes, blue screens etc., caused by application bugs or viruses.

Although the advent of these more secure operating systems should be generally welcomed, it is a great shame that Microsoft failed earlier both to provide and promote safe mechanisms for I/O access that would be compatible with the newer systems, and make better provision for "backwards compatibility" modes in the new generation OSs. Such facilities would have enabled "legacy" programs, which are written to assume they have access to all the machine's resources, to continue to be run safely without the need to resort to tricks like AllowIO.

Second, although it's beyond the scope of the article (and these comments) to explain how AllowIO works, readers should perhaps be made aware that it is by circumventing and disabling some of the Windows protection mechanisms mentioned above. There is some inherent risk associated with doing this. The whole PC system is again laid open to corruption by (accidental or deliberate) errors in applications code.

It's also possible that other (as yet unidentified) internal Windows mechanisms may rely on, or assume, that the CPU protection registers are set up in a certain way, and that consequently these mechanisms might not work correctly when AllowIO is in use. I'm not sufficiently familiar with the innards of Windows OSs to understand exactly what these risks might be.

Nonetheless AllowIO is undoubtedly useful. There are some steps that can be taken to minimise the risks associated with using it, as follows:

1. Update your anti-virus software and check that a full system scan gives your machine a clean bill of health before trying AllowIO.

2. AllowIO/TK3 should not be run with any other program known to use I/O. Preferably all other applications should be closed down while TK3 is being run in this way, and no internet connection should be made while running it.

3. The command "allowio tk3prog.exe /a" breaks more protection mechanisms than is necessary to run TK3, which only requires access to the printer port. It is preferable to use the alternative command "allowio tk3prog.exe 0xnnn", which grants access specifically to the printer port, where nnn is the port address and can be found on TK3's configure PCB screen. The command "allowio tk3prog.exe 0x378" would be the one that works for most people.

4. Once loaded into your system, the porttalk.sys driver installed by AllowIO is a security loophole that could be exploited by viruses, internet hackers etc. Exiting TK3 does NOT unload this driver; it will stay there until the machine is rebooted. It should be specifically unloaded when the TK3 session is over.

To do this, as well as extracting the AllowIO.exe program from the .zip file, also extract the program **uninstall.exe** into the installation directory as described in the article. Then, when finished with TK3, open a CMD window in the installation directory and type "uninstall" at the prompt. This will unload the driver. (I also take the further precaution of scrambling the filename of the porttalk.sys driver in my /drivers

directory so that a virus can't easily find it and load it.)

Malc Wiles, via email.

Mark Jones replies:

Fine on the comments and I don't wish to argue. My article could have gone on forever with the details. I agree with the issue over virus attacks. However, if I were to write a virus (which I have no desire to do) then I would not rely on an OS and AllowIO combination to be present to allow it to work!

Some other thoughts that spring to mind at this time given your ability with PIC projects. I am an Amateur Radio licence holder, here are some projects that I think would be most useful:

1. **A voltage monitor.** Most modern radios (and probably loads of other kit) rely on an external 13.8V supply. It seems to me that there are some solid state devices between my radio and perhaps 25V d.c. or more providing the regulation. A failure in this device would be catastrophic for my equipment. Could you make a voltage monitoring device with l.e.d. indication for over and under voltage protection?

If over voltage conditions exist it would need to remove the supply to the equipment very fast, perhaps even a direct short and rely on the in-line fuse. I looked at such devices a some years ago and ended up using an MC3423 driving an SCR-based crowbar. The calculations for the current requirement for the SCR blew my mind ...

2. **A.C. (mains) current monitor.** I have just purchased a mains adaptor that provides a visual indication of the current consumption from a 13A socket. A most useful device. In my "shack" I have so many mains appliances, all from a single socket. This device gives me confirmation that I am not overloading the socket. Seems a good idea.

Mark Jones, via email

Thank you Malc and Mark for your extra input on this subject. Readers, let's us know if you would like Mark's project ideas implemented through EPE.

UNSQUARE ROOTING

Dear EPE,

I know of the method of square rooting described by Ken Beard in *Readout* Nov '02! As I said in my article *Using Square Roots with PICs* (Aug '02) there are various methods to find square roots and I believe this would be the slowest. Such a routine would require many iterations for large numbers. For example, the square root of 16 million would require the routine to loop 4000 times, very slow! No wonder I dismissed it as a viable method.

Peter Hemsley, via email

Thanks Peter, I'm not at all surprised by your answer. My response at the time was that the routine would probably take many cycles before it reached an answer.

TOOLKIT TK3 AND W2K

Dear EPE,

I have just bought the Magenta Super PIC Programmer kit, which came with *PIC Toolkit TK3* software. I have installed the software on a Windows 2000 PC but keep getting a "privilege exception" error message. Any ideas?

Paul Edwards, via email

TK3 was not written to run on W2K, Paul, but Mark Jones' useful article Using TK3 with Windows XP and 2000 of Oct '02 shows how it can be done (also see previous column).

TASM AND MPASM

Dear EPE,

Many EPE PIC projects seem to be written in TASM. What are the differences between TASM and MPASM and can you list down some of the reference books and websites that introduce both of these assembly languages?

Donald, via email

Differences between the TASM and MPASM dialects are discussed in my PIC Tutorial of Mar-May '98, Donald, a cut down version of which is included with the free Toolkit TK3 software available for download from our ftp site. TK3 also translates between them.

There are no reference books or web sites on TASM that I am aware of, but I recommend that you should write your programs in MPASM, the more universal dialect of the two.

VINYL TO CD

Dear EPE,

Andy Flind and anyone else thinking of preserving their old vinyl on CD (*Readout* Nov '02) might find <http://www.delback.co.uk/lp-cdr.htm> of interest. Together with the separate FAQ (to which there is a link), it amounts to 26 pages of solid good advice and loads of links to other sites of interest. There is an intriguing comment about the software that Andy had problems with:

"... Easy CD Creator is bundled with many CDR drives, and its basic disc writing engine is very solid, provided it works on your system. (There have been many stories from people who were never able to get Easy CD Creator working, and the general conclusion seems to be that it will either work straight out of the box, or it'll never be right!)"

A site that offers excellent advice about copying 78rpm discs is <http://www.rfwilmot.clara.net/repro78/repro.html>. There is also a circuit of a preamp that will provide the correct equalisation for 78s pre-1955 and LPs, as well as the RIAA curve.

Barry Taylor, via email

Thank you Barry.

PIC SEARCH

Dear EPE,

Do you have any information on PICs? I am doing a remote control car project in college which requires a PIC to control its sensors and some movement. Do you have any information that could help me in my research?

Ray Coventry, via email

We have done many PIC projects over the years Ray, but nothing specifically on model car control, although this month's Brainbot Buggy might interest you. If you are looking to just find what PICs are available, browse www.microchip.com. We are accustomed to publishing projects based on the PIC16x84 and PIC16F87x families, with PIC16F62x projects just beginning to emerge. You would be advised to select from these ranges at your present stage of learning.

If you want to learn about PICs in detail, consider buying my Assembly For PICmicro V2 CD-ROM and its associated demo and development board, as advertised in any recent issue, including this one.

Alternatively, you could consider my original PIC Tutorial of March to May '98, which is available as back issue photocopies from the Editorial Office.

R.F. COMMS

Dear EPE,

Have you detailed how to build transmitter and receiver circuits for communications over short distances, something like an AM frequency over 100 metres? Or are you planning to do a project on such?

Your "old BR giant digits" (*PIC Big Digit Display* of May '02) was a good read.

NC, via email

No, NC, not specifically, but perhaps the circuits in last month's EPE Minder design might help you, of course such transmission must use approved modules or fall under amateur radio licenced operation.

Thanks for Digits comment - I enjoyed the challenge!

SHOP TALK

with David Barrington



Tesla High Voltage Transformer

Would-be constructors of the *Tesla High Voltage Transformer* project MUST take heed of the warning given in the article regarding the "very high voltages" associated with this circuit. Having said that, all of the semiconductors, capacitors (except homemade C5), TO3 power transistor insulating kit and a suitable mains transformer are regular stock items and should be available from most of the components advertisers in the magazine. Note that the mains transformer must have a 12V secondary rating of at least 2A minimum.

Ignition coils are available from car spares retailers, motorists' discount stores and, second-hand, from breakers' yard. Cost, new, about £12. Likewise, polythene tubing for coupling the spark-gap control and for additional safety insulation is stocked by home brewers' or aquatic supply shops.

Acrylic sheet, 2mm thick, is, we understand, retailed by most major DIY outlets and (by post) from **C&A Building Plastics, Bidder Street, London, E16 4ST** (☎ 0207 474 0474). A sheet 102cm by 75cm (40in. x 30in.) costs around £6, but postage/delivery charges exceed the price of the sheet, so try for a local source first.

Plastic rain water and waste pipe for the coil formers is also stocked by DIY outlets and plumbers' merchants. Brass strip and plastic rods are obtainable from most model shops.

The printed circuit board is available from the *EPE PCB Service*, code 382 (see page 155).

Brainibot Buggy

The light-dependent resistor (l.d.r.) used in the *Brainibot Buggy* project is the miniature version of the ubiquitous ORP12 device and should have a resistance of around 20 kilohms at 10 lux. A suitable device should be stocked by most of our components advertisers.

A complete *Brainibot* kit of parts, including chassis hardware and motors is available from **Magenta Electronics** (☎ 01283 565435 or www.magenta2000.co.uk) for the inclusive sum of £19.99 (overseas orders will incur an additional postage charge, quote code KIT 910 when ordering. We understand that readers may purchase the 3V d.c. miniature motors separately; to date we do not have a price and Magenta should be contacted direct regarding cost.

For those readers unable to program their own PICs, a ready-programmed PIC12C508/12C509 microcontroller can be purchased from **Magenta** (see above) for the inclusive price of £3.90 each (overseas add £1 p&p). The software is available on a 3.5in. PC-compatible disk (*EPE* Disk 6) from the *EPE Editorial Office* for the sum of £3 each (UK), to cover admin costs (for overseas charges see page 155). It is also available for free download from the *EPE* ftp site, which is most easily accessed via the click-link option at the top of the home page when you enter the main web site at www.epemag.wimborne.co.uk. On entry to the ftp site take the path **pub/PICS/Brainibot**, downloading all files within the latter folder.

On a point of software. We would point out that the robot design, instructions and PIC code copyright has been retained by **Analogue Information Systems Ltd**. However, the software is released free to readers on a "non-commercial use only" basis.

The small printed circuit board is available from the *EPE PCB Service*, code 383 (see page 155).

Wind Tunnel

All the major components used in the prototype model of the *Wind Tunnel* project are RS devices and can be ordered through any *bona-fide* stockists, including some of our advertisers. If you have trouble finding a local source, you can order direct (*credit card only*) from **RS** on ☎ 01536 444079 or through the web at rswww.com. A post and packing charge will be made.

If you are prepared for an outlay of just over £40, the 230V a.c. 26W self-starting industrial axial fan, with induction motor, carries the RS order code 223-130. The "finger" guards are coded 252-9878.

The chassis-mounting 75VA 230V a.c. mains transformer, with independent twin 12V a.c. secondaries (37.5VA per sec.) is coded 805-209. The "side-looking" infra-red opto-sensor type IS436 consists of a photodiode, amplifier, voltage regulator and Schmitt trigger detector, complete with transistor output, all in a 3-pin package. The RS code for this device is 197-025. The HUF75329P3 n-channel MOSFET is coded 294-9648. The high-power finned (14°C/W) heatsink order code is 234-2306.

The alphanumeric I.c.d. module (X2) used in the prototype is a standard two-line 16-character per line device and should present no purchasing problems. Display pinout connection details are included in the article for the two "standard" formats. Note that toggle switch S1 must be a heavy-duty type rated at 15A.

Fully programmed PIC16F628 microcontrollers can be purchased from **Magenta Electronics** (☎ 01283 565435 or www.magenta2000.co.uk) for the inclusive price of £4.90 each (overseas add £1 p&p). The software is available on a 3.5in. PC-compatible disk (*EPE* Disk 6) from the *EPE Editorial Office* for the sum of £3 each (UK), to cover admin costs (for overseas charges see page 155). It is also available for free download from the *EPE* ftp site, which is most easily accessed via the click-link option at the top of the home page when you enter the main web site at www.epemag.wimborne.co.uk. On entry to the ftp site take the path **pub/PICS/WindTunnel**, downloading all files within the latter folder.

Back To Basics Part 1 – Hearing Aid/Audio Amplifier

We do not expect any component buying problems to be encountered when putting together parts for the *Hearing Aid* and *Audio Amplifier* projects, the first items in part one of the *Back To Basics* series.

Most components advertisers should stock the small plastic spindles that can be used with preset potentiometers. If not, opt for a standard miniature rotary carbon type. Miniature electret microphone inserts and crystal earpieces seem to be in plentiful supply.

PLEASE TAKE NOTE

Biopic Heartbeat Monitor

(June '02)

Some readers have reported that insufficient voltage/current is being supplied by their PC's serial port to drive the output side of the 74OL6000 opto-isolator recommended as a replacement for the obsolete TLP215 device. The voltage at pin 6 of this i.c. should be about +5V.

It is suggested that readers with this problem use the 74OL6010 device instead, which requires less current, but it is an open collector device and a resistor of, say, 1k should be wired between its output (pin 5) and the +Ve line from the PC. However, if you intend to only use the thumb probe (and NOT monitor your heart using chest probes), the opto-isolator could be powered at 5V from the unit's own supply.

Also note that unless a "crossover" cable is used, the signal connection from IC5 pin 5 should go to the D-connector (socket SK3) pin 2, not pin 3 as shown in Fig.2 and Fig.3. SK3 is a 9-pin female type. A suitable cable is a D-range 9-way male to female (straight through), Maplin part number VD73Q.

PIC-Pocket Battleships

(Oct '02)

Page 755, Fig.3. In the circuit diagram, switch S1 and S2 should connect to Port B5 via R2 (not B6 as shown) and S3, S4 and S5 should go to B7 via R1 (not B5). The component layouts, Fig.4 and Fig.5, are correct.

PIC Controlled Intruder Alarm

(Apr '02)

Revised PIC software in a which an entry/exit zone bug has been fixed is on the ftp site and *EPE* Disk 5.



NEWSAGENTS ORDER FORM

Please reserve/deliver a copy of *Everyday Practical Electronics* for me each month

Signed

Name and Address

.....

..... Post Code

Everyday Practical Electronics is published on the second Thursday of each month and distributed S.O.R. by COMAG
Make sure of your copy of EPE each month – cut out or photostat this form, fill it in and hand it to your newsagent.

BACK TO BASICS



BART TREPAK

Part One

This short series illustrates how useful circuits can be designed simply using transistors as the active components.

BACK to basics is a phrase often used by politicians and others who have run out of ideas but, as a glance through any issue of *EPE* will reveal, this can certainly not be the case here. There seems to be no limit to the ingenuity of readers to come up with new applications using modern components, which today often means the use of integrated circuits or even microcontrollers.

This means, for example, that a circuit diagram can sometimes just consist of a box outline marked "IC1" to which a few external components such as resistors, relays and speakers etc. are connected.

The box, we may be told, contains ten, a hundred or even a few thousand transistors, which makes the circuit diagram very neat and the project very easy to build, but trying to understand what is actually going on inside the integrated circuit (i.c.) and how the circuit works can be very difficult for the beginner.

It has to be said, though, that it is usually not vital to understand what is inside the box in order to get the circuit working, any more than it is necessary to be familiar with the workings of the internal combustion engine to be able to drive a car.

Many people enter this hobby simply wanting to build something useful, either to use themselves or to show to their friends or family. An interest in the theory often comes later when more complex problems need to be solved.

SOMETHING SIMPLE

This short series presents a number of simple but nonetheless useful gadgets for the beginner to build and use. They could also form the basis of simple designs for GCSE projects.

All require no more than three transistors, which makes them easy to understand and simple to build. Naturally, with so few components, these gadgets cannot hope to match

the performance of their commercially built integrated circuit based equivalents. But they all work, and it may even come as a surprise after reading about computer "chips" containing millions of transistors, just what can be achieved with only three. Before considering these circuits, though, a brief explanation of basic transistor operation may be helpful.

BASIC TRANSISTOR

Transistors form the basis of all electronic circuits from the simplest to the most complex microprocessor devices available, and although many modern i.c.s use field effect transistors (f.e.t.s) which operate on slightly different principles, we will consider bipolar junction transistors (b.j.t.s) as these are much cheaper.

Most transistors have three terminals, which in a b.j.t. are called the emitter (e), base (b) and collector (c), as notated on the circuit symbol in Fig.1a. This shows an *npn* type which operates with the collector at a positive voltage with respect to the emitter, while Fig.1b shows a *pn*p type where the operation is the same but the collector and base voltages are inverted (negative) with respect to the emitter.

The terms *n* and *p* refer to the type of semiconductor material used, which either contains an excess of negative (*n*) charge carriers (electrons) or positive (*p*) charge carriers (holes), the flow of which constitutes a *current* within the semiconductor.

Diodes, which conduct only in one direction, consist of two layers sometimes referred to as a *pn* junction (Fig.1c), whereas transistors contain three layers and thus have two junctions called the base-emitter and the collector-base junctions.

Junctions of the *pn* type do not obey Ohm's Law ($V = IR$), unlike resistors where the current flowing through the device is proportional to the voltage potential across it.

In the reverse direction (*p* region, negative), the current *I* through a diode is effectively zero, irrespective of the applied voltage. When forward biased (*p* positive and *n* negative) silicon diodes, when conducting, exhibit a small forward voltage drop of around 0.6 volts, irrespective of the current flowing.

This is, of course, a simplification, and also assumes that the maximum current or voltage ratings are not exceeded. The 0.6V drop is also only approximate (it is lower at very small currents and can be as high as

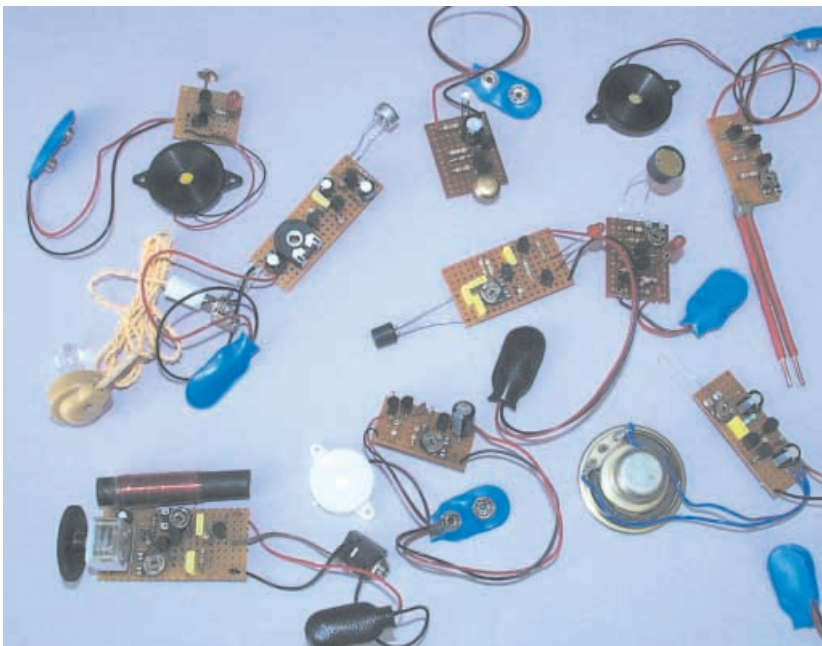

The full range of simple transistor-based circuit assemblies described in this series.

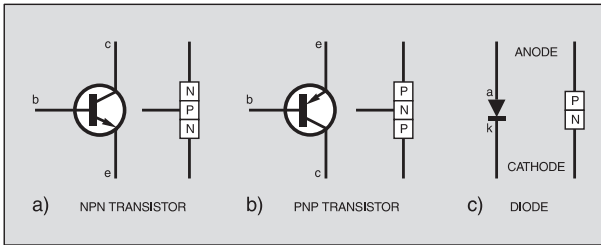

Fig. 1. Transistor and diode symbols, and equivalent internal structure.

0.7V or more for high currents). It is also only true for *pn* junctions made from silicon, which is the material used for most modern transistors and diodes.

Some other semiconductor materials exhibit a higher forward voltage drop, so that a *pn* junction made from gallium arsenide (a material used in the manufacture of l.e.d.s), for example, has a forward voltage of about 1.5V. Conversely, a *pn* junction made from germanium (now not often found in semiconductors) exhibits a voltage drop of about 0.3V.

In normal use, the base-emitter junction of a transistor (which is and acts like a diode) is forward biased. Consequently, current flows and it therefore exhibits a voltage drop of 0.6V, while the collector-base junction (which is also a diode) is reverse biased.

The operation of the device is best understood as a kind of current-controlled current sink. The current flowing between the collector and emitter, I_c , is not determined by the voltage across it, but only by

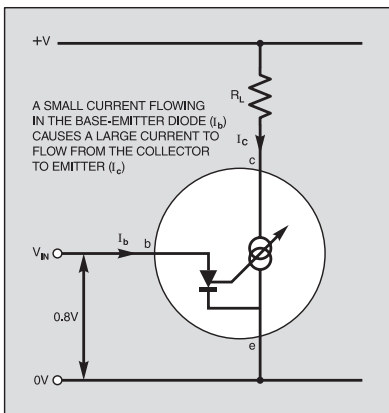

Fig. 2. Approximate equivalent circuit of an npn transistor.

the current flowing from the base to the emitter, I_b , as shown in Fig. 2.

The result of current flowing into the base-emitter path causes a greater current to flow through the collector-emitter path, for reasons beyond the scope of this article.

The collector current I_c is higher than the base current, I_b , by a factor known as the current gain of the device, often denoted by Greek letter β (Beta) or h_{FE} .

Depending on type and intended application, transistors can be manufactured to have a current gain of between 20 and 500, although for the transistor types used in this series a value of 100 is typical. This is not an exact value and some specimens could have a gain as low as 50 while others may have a gain of 150 or more, and any

practical circuit should make provision for this.

An important point to appreciate about all of this is that the collector current depends only on the base current and not the collector voltage, as long as this is a little higher than the voltage at the emitter. In this sense therefore, the collector is a current source.

TRANSISTOR AMPLIFIER

The circuit diagram in Fig. 3 is for a typical simple audio amplifier that demonstrates how a single transistor can be used in a practical situation. It is intended for amplifying small voltages from a microphone to drive an earpiece. No constructional details are offered as it is simply an example.

The term *amplifier* is perhaps a bit of a misnomer for the circuit as it conjures up an image of the small signal from say a microphone somehow being magnified, by passing through a transistor, to a level large enough to drive a powerful loudspeaker, in a way analogous to an image being enlarged by a lens.

What really happens is that the microphone signal is simply used to control the much larger current available from the power supply or battery and this is used to drive a small loudspeaker (the earpiece). The transistor simply enables us to control a large (collector) current with a smaller (base) current.

In Fig. 3, resistor R_L (often called a load resistor – hence R_L) is shown connected between the transistor's collector and the positive power line. If the base current is increased from zero (by varying the value of the base resistor R_B , for example), the collector current will also increase from zero.

This causes the voltage across load resistor R_L to increase and thus the voltage between the emitter and collector to fall. Eventually, if the base current continues to be increased, a stage will be reached when the current flowing through R_L is so large that the voltage developed across it will equal the supply voltage and no further increase will be possible.

The voltage across the emitter-collector will then, of course, equal zero because all of the available supply voltage is developed across R_L . Since the collector current is directly proportional to the base current, the device can be used to make a perfect but larger reproduction of the base current or, in other words, to amplify small signals.

When discussing the operation of circuits, it is more usual to talk in terms of voltages at various points rather than the

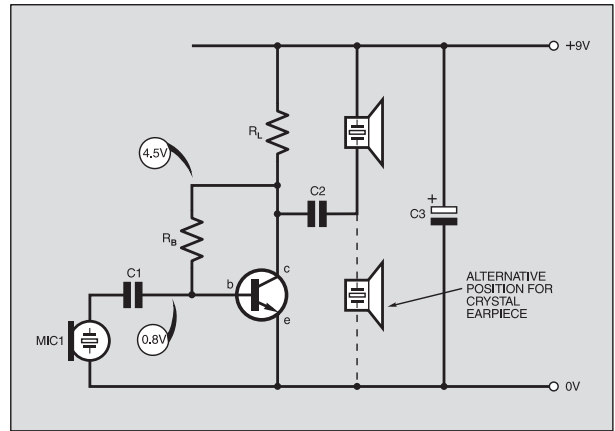

Fig. 3. Basic common emitter audio amplifier.

currents flowing through the devices. Voltages are after all much easier to measure (as no wires need to be cut or components disconnected to enable a meter to be inserted) and they can all be expressed with respect to some convenient reference point, such as 0V.

Thus we can say that when the base voltage is increased from zero (causing the base current to increase once the 0.6V base-emitter threshold is exceeded), the collector voltage falls from the supply rail value towards zero. Again only a small change in the base voltage is required to effect a large change in the collector voltage.

The values for resistors R_B and R_L must be chosen so that when no signal is present, the collector current is such that the voltage at the collector is at around half of the supply voltage (i.e. 4.5V for a 9V supply). This allows the collector voltage to uniformly swing *within* the range 0V to 9V in response to an input signal without "hitting" either supply rail (a situation commonly known as "clipping").

Within this range, the output signal at the collector faithfully follows the input signal and provides the maximum undistorted output (providing the capacitor values are correctly chosen).

CAPACITIVE COUPLING

The a.c. microphone signal is coupled to the base of TR1 via a capacitor C1. This prevents any d.c. voltage in the microphone circuit (or preceding stage in other applications) from upsetting the transistor bias conditions.

Thus the current flowing into the base depends only on that flowing through resistor R_B and the a.c. signal generated across the microphone.

The microphone signal thus causes the collector current to vary in sympathy, but by a much greater amount. The voltage at the collector will therefore also vary in sympathy with the microphone signal and the variation will of course be much greater than the signal voltage. In other words, amplification has been provided.

It is often also desirable to block d.c. voltages at the output from the collector and pass only the a.c. signal to the load (which in other applications could be another similar stage). This is done by placing another capacitor, C2, in the circuit as shown.

To work correctly, the impedance of the load would need to be about 10 times that

of R_L to avoid loading the output unduly and reducing the output voltage. In this example, if a value of $4.7k\Omega$ is assumed for R_L , this circuit would be suitable for a crystal earpiece, which has a very high d.c. resistance. Indeed it is so high, in fact, that a capacitor is not actually required when using such an earpiece.

Note that the circuit cannot be used to drive a loudspeaker. Small loudspeakers generally have a much lower impedance of around 8Ω to 40Ω . However, an 8Ω speaker would require R_L to have a value of 0.8Ω , which would mean that the transistor current would need to be $5.6A$ to maintain the collector voltage at $4.5V$! This would clearly require a different approach.

For the signal to be handled correctly, the impedance of the power supply should be as low as possible. With battery supplies the effective impedance tends to increase as the battery becomes discharged and for this reason it is a good idea to connect a capacitor ($C3$) across the supply rails to keep this impedance low.

Since it is a capacitively coupled a.c. signal, it is possible to connect the earpiece (or indeed another stage) from the output to either supply rail. Note that a *pnp* transistor could be used in this circuit if the battery connections are reversed (i.e. $+9V$ to the emitter, $0V$ to the collector).

NEGATIVE FEEDBACK

Connecting the bias resistor R_B to the collector rather than to a fixed voltage, such as the positive supply rail, provides negative feedback and stabilises the circuit against temperature and transistor gain variations.

This is important because the large variation in gain of transistors would otherwise mean that each repetition of the circuit would have to be individually set up. By connecting this resistor to the collector, a transistor with a large gain would pass a larger collector current. This reduces the collector voltage, causing a smaller base current to flow, tending to return the collector to the mid supply point. A similar

but opposite response takes place if the transistor specimen has a lower gain.

Using resistor R_B in this configuration provides what is known as *d.c. negative feedback*. It is used to compensate for changes in collector current irrespective of how they are caused, not only because of transistor gain spreads but also due to variations in the base current caused by temperature changes, and indeed variations in the signal itself.

The penalty for using negative feedback is therefore a reduction in gain of the circuit, but the benefits are a reduction in distortion, an increase in the frequency response, as well as reduced sensitivity to temperature and transistor gain variations. Adding more stages can easily compensate for the lower gain of the stage.

The circuit in Fig.3 shows an example of a linear transistor application where the output is, as far as possible proportional to the input. There are several examples of its use in the simple projects described in this series.

HEARING AID

THE first project in this short series is a simple Hearing Aid. It is not intended to be used as an alternative to medically approved hearing aids. This simple design consists of a microphone and a three-stage transistor amplifier. It has a manual volume control and is powered by a $9V$ PP3 battery.

Its circuit diagram is shown in Fig.4. The microphone (MIC1) is a miniature electret type which contains an internal amplifier so that a positive d.c. supply is required across it, provided here via resistor $R1$.

Despite the internal amplifier, the output signal from the microphone is too small to drive an earpiece and it needs to be amplified. In this application, three transistor stages are used to amplify it.

The signal from the microphone is a.c. coupled via capacitor $C1$ to the twin-transistor stage around $TR1$ and $TR2$. These are d.c. coupled and the much larger gain obtainable using two transistors enables more feedback to be used, thus making the circuit more immune to variations caused by gain spreads and temperature changes.

The base current for $TR1$ is obtained via resistor $R3$ from the voltage developed across $R4$ by the current passed by $TR2$. Capacitor $C2$ removes the a.c. content of the signal so that only d.c. feedback occurs via this path, and limits signal gain.

Capacitor $C3$ causes a reduction in the gain of higher frequencies to ensure that the amplifier remains stable. The low frequency response is determined by the impedance of the capacitors $C1$ and $C2$, which are given relatively low values. The middle frequencies are therefore boosted more than low frequencies, while higher frequencies are also suppressed making speech more intelligible and the unit less sensitive to interference from mains hum ($50Hz$). If you wish to experiment, the frequency response of the amplifier can be tailored to requirements by altering the values of these capacitors.

The load resistance ($VR1$) of $TR2$ is made variable and functions as a Volume control, enabling the amplitude of the signal fed to the final earpiece driver stage formed around *pnp* transistor $TR3$ to be varied. Capacitor $C4$ ensures that the d.c. voltage at $VR1$ does not affect $TR3$.

The stability of the circuit is aided by the use of capacitor $C6$ fitted directly across the supply line, and by the inclusion of resistor $R7$ and $C5$ in the supply feeding transistors $TR1$ and $TR2$.

CONSTRUCTION

As with all of the projects in this series, the circuit is built on a small piece of stripboard, as illustrated in Fig.5.

With this method of construction, it is just as important to break those connections which are not required as it is to make those that are, so that the first step should be to cut the tracks as shown. This

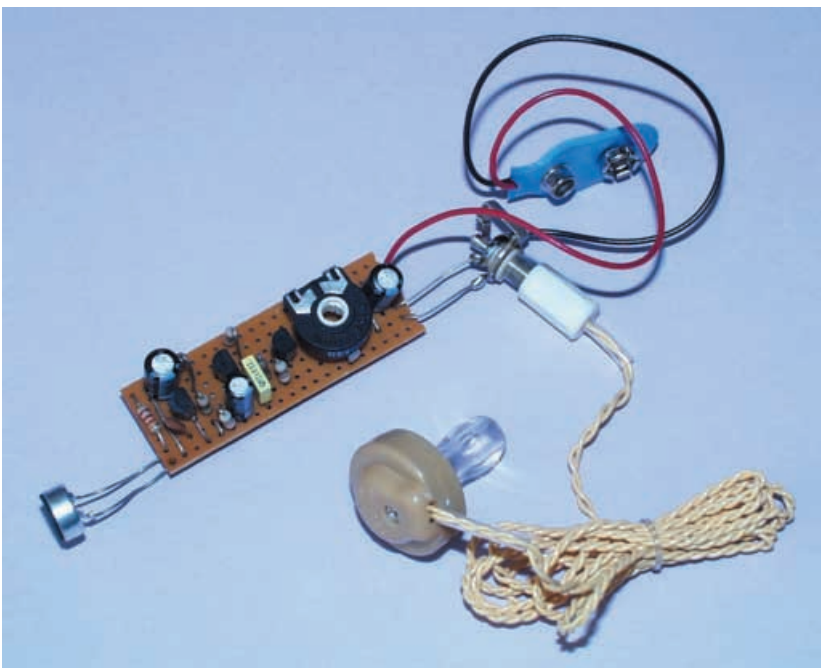

COMPONENTS

Resistors

R1	22k
R2	470k
R3	1M
R4	1k
R5	3M3
R6	10k
R7	100Ω

All 0.25W 5% metal film.

Potentiometer

VR1	47k preset with spindle (see text)
-----	------------------------------------

Capacitors

C1	1n ceramic disc, 5mm pitch
C2	470p ceramic disc, 5mm pitch
C3	100n ceramic disc, 5mm pitch
C4	10n ceramic disc or polyester, 10mm pitch
C5, C6	100μ axial elect., 16V (2 off)

Semiconductors

TR1, TR2	2N3904 npn transistor (2 off)
TR3	BC558 pnp transistor

Miscellaneous

MIC1	electret microphone insert
X1	crystal earpiece with lead and 3.5mm plug

Stripboard, 7 strips x 21 holes; 3.5mm socket, switched (see text); PP3 battery and clip; case to suit; connecting wire; solder, etc.

Approx. Cost
Guidance Only

£8

excl. case and battery

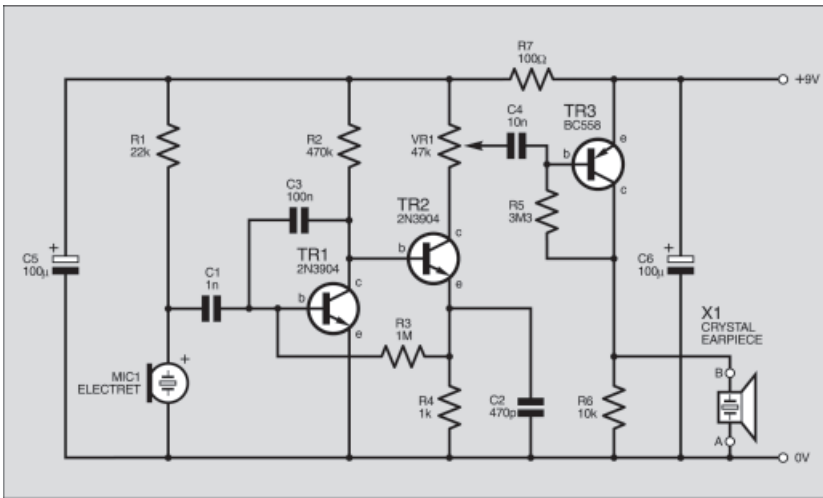

Fig.4 (above).
Circuit diagram for
the Hearing Aid.

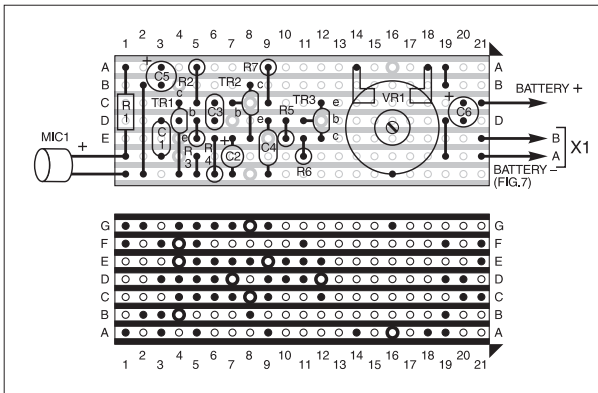

Fig.5 (left).
Hearing Aid strip-board
layout and details
of track breaks.

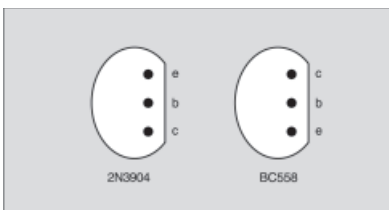

Fig.6. Transistor pinouts, base view.

can be done with a 5mm drill bit or the special tool with a plastic handle available for the purpose.

Assemble the board in order of component size, noting that several resistors are mounted vertically.

Virtually any small-signal transistors could be used, correctly chosen as npn/pnp types, but note that pinouts between different types can vary. The pinouts for the suggested transistors are shown in Fig.6. Ensure that they and the

electrolytic capacitors are connected the correct way round.

Electret microphones are available with flying leads or as capsules without any leads. If the latter type is purchased, first solder two resistor cut-off wires to the two pads on the back of the component.

The microphone must be connected the right way around and the negative lead should be soldered to the 0V rail (battery negative). The microphone's negative lead is the one connected to its metal body. This can be determined visually or by means of a multimeter set to the ohms range.

The crystal earpiece is normally available with a lead terminated in a 3.5mm mono jack plug and a suitable switched socket should be purchased for this (the switch is used to switch the 0V line from the battery). If this is an open type as shown in Fig.7, it will have a switched contact which opens when the plug is inserted, and so will need to be modified to close when the plug is inserted.

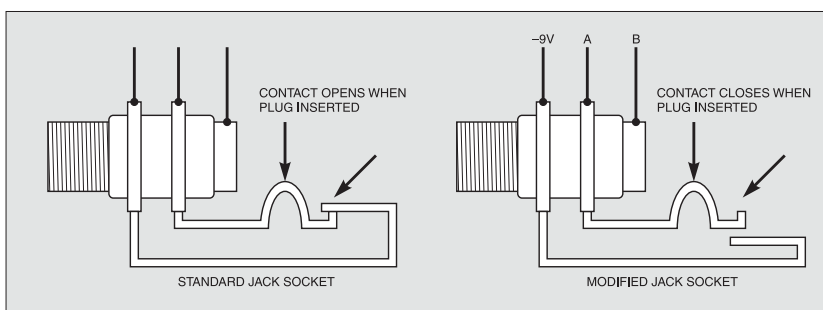

Fig.7. Modifying a 3.5mm jack socket to act as a power on/off switch.

This can be done by bending the contact to the position shown. Alternatively, a stereo socket could be used with the third or inner contact used as the switch. The mono plug will short-out the outer and middle contacts when the plug is inserted, thus making the battery connection while the tip or inner contact of the plug is connected to the collector of TR3.

Volume control VR1 is a 15mm diameter preset which is available with an optional spindle. Alternatively, a standard panel mounting potentiometer can be used and wired to the board with flying leads.

The circuit, together with a PP3 type battery, should be mounted in a box, although no recommendation of box type is made for any project in this series.

Note that the circuit is extremely sensitive and output wiring to the earpiece socket should be kept well away from the microphone. Some foam damping between the box and the board/microphone is also desirable to prevent knocks and other mechanical shocks from being transmitted to the microphone and amplified. If mains hum is a problem, the value of capacitor C1 should be reduced.

AUDIO POWER AMPLIFIER

IN the preceding *Hearing Aid* project, the output of the amplifier is used to drive a crystal earpiece, which is fine for personal listening but very often a loudspeaker provides a better output enabling a number of people to listen simultaneously, or for the sound to be heard from a distance.

The Audio Power Amplifier circuit described now enables this to be done. It would also make an ideal loudspeaker output amplifier for use with small projects.

LOW IMPEDANCE

The problem with driving speakers is due to their low impedance, which can be as low as four ohms in high power units, although more commonly it is eight or 15 ohms.

Connected as the collector load in a common emitter amplifier, the transistor and speaker would need to pass a very large d.c. current, as discussed earlier.

As it would be unwise to have such a large current flowing continuously through the speaker, a separate load resistor could be used together with a coupling capacitor, but this would still involve a very large current flowing continuously through the transistor and resistor. To enable a speaker to be connected, some way of increasing its apparent impedance must therefore be found.

In the past, a transformer was often used, but these tend to be expensive and heavy so now power transistors of various types are used. The circuit presented here is based on an emitter follower amplifier where the load (speaker) is connected in the emitter circuit, as shown in Fig.8.

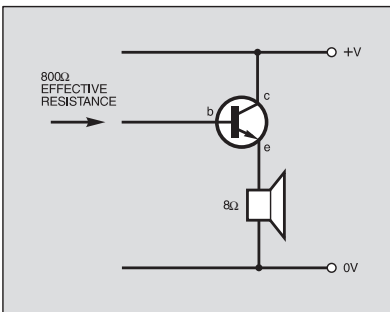

Fig.8. Loudspeaker driven by an emitter follower.

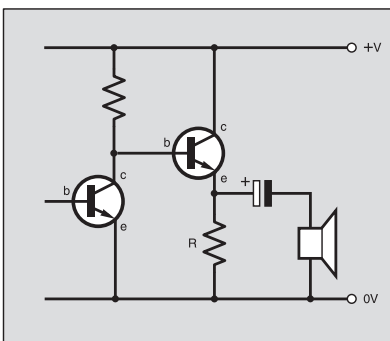
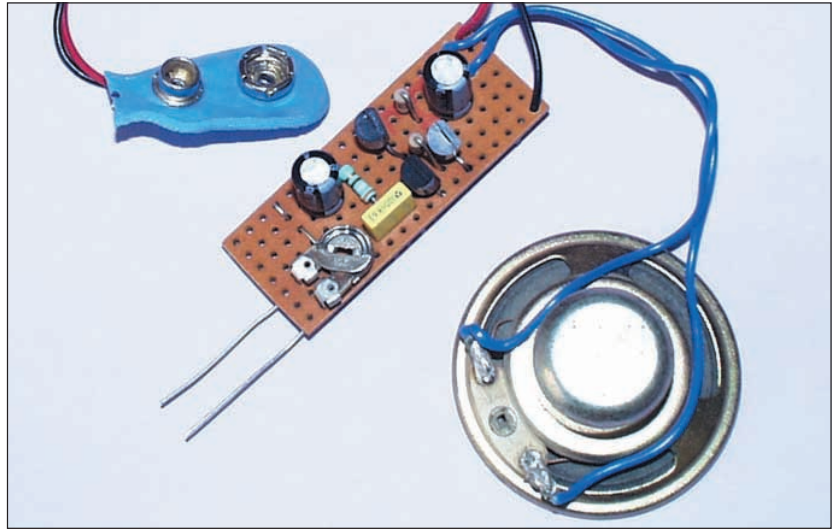

Fig.9. Capacitively coupled loudspeaker stage.



This connection provides no voltage gain as the output (emitter) voltage is effectively the same as the input except for the 0.6V base-emitter voltage drop (which is why the circuit is called an emitter follower amplifier). However, the input impedance of the stage looking into the base is increased by the gain of the transistor.

With an 8 ohm speaker and a gain of 100, the effective speaker impedance is now a more respectable 800 ohms. This allows an amplifying circuit to be followed by a common emitter stage as shown in Fig.9. Here an emitter load resistor, *R*, is used and the loudspeaker is capacitively coupled in parallel with it.

COMPLIMENTARY OUTPUT

Although a high value of collector load resistor can be used in the amplifying stage, enabling the collector voltage to be set to the mid-supply point, this would still leave the problem of the low value of resistor *R*, but here another trick can be used.

During the positive half-cycle, the majority of the current flows through the capacitor and the speaker. Resistor *R* is not required at this time and the current which flows through it is simply wasted. In this situation it would be better if the resistor were not present.

Unfortunately, during the negative signal half-cycle, current must flow through the resistor to discharge the capacitor, and then it is the transistor current which is wasted.

Remember that the *average* d.c. voltage at the emitter is set to approximately the same voltage as that at the amplifier's base.

If the load resistor could be replaced by a resistor which varied its value depending on whether the positive or negative half-cycle were being amplified, this wasted current could be eliminated.

This can be done by replacing resistor *R* by a *pnp* transistor emitter follower as in Fig.10, using TR3. This transistor automatically drives the speaker during negative half-cycles, but switches off during the positive half-cycles when the *nnp* transistor TR2 is turned on.

If the junction of these two transistors is set at the mid-point voltage (to achieve the maximum undistorted output), then each transistor will automatically conduct in its own half-cycle while the other turns off, and when no signal is present both transistors will be off, reducing the current drain to zero.

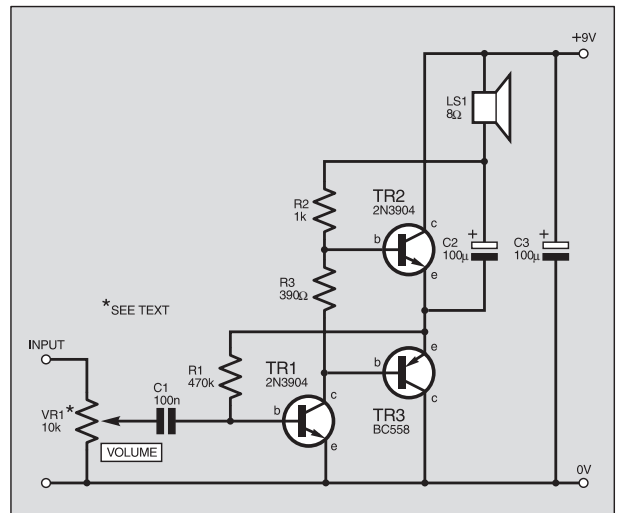

Fig.10. Audio Power Amplifier circuit diagram.

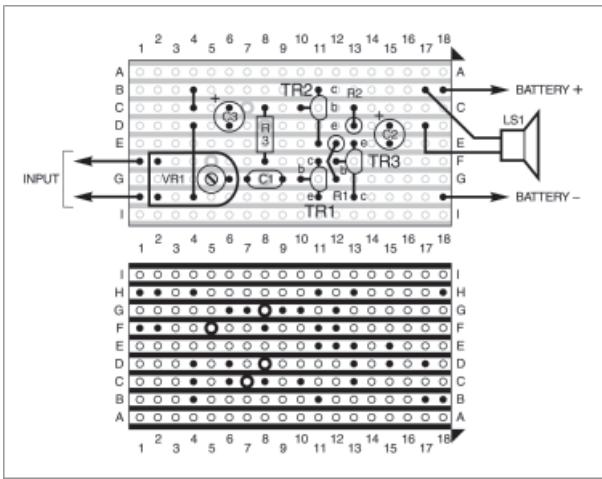

Fig. 11. Audio Power Amplifier stripboard component layout and details of track breaks.

DISTORTION

In practice, having a zero current drain introduces a particularly objectionable form of distortion. This occurs at low signal levels when one transistor cuts off before its partner begins to conduct. To eliminate this so called *crossover* distortion, both transistors are made to conduct slightly when no signal is present. This is done by fitting a low value resistor, R3, between the bases of TR2 and TR3, as shown in Fig.10.

During the positive half-cycle of the input signal, TR1 is turned on and so base current for *pnp* transistor TR3 flows through it, and can be considerable when required.

During the signal's negative half-cycle the base current for *npn* transistor TR2 must be supplied via resistor R2. To enable sufficient current to flow, this resistor must have a relatively low value, but for maximum voltage gain its value should be as high as possible.

This conflicting requirement is solved using a trick called *bootstrapping* where an identical signal to that appearing at the bottom end of resistor R2 is applied to the top end via capacitor C2, which is also used to couple the output signal to the loudspeaker. Since substantially the same signal voltage appears at both ends of R2, there will be virtually no signal current flowing through it.

This increases the *apparent* resistance of R2 at the signal frequency, so ensuring high gain, while its relatively low *actual*

resistance ensures sufficient base drive to TR2.

With the values given, the circuit has a sensitivity of about 10mV for a power output of about 560mW at a frequency of 1kHz. This may not sound like a lot compared to the power pumped out in rock concerts, or even by hi-fi amplifiers, but it is very loud for normal listening and may even need to be reduced by the Volume control, VR1.

The no-signal quiescent current should be about 4mA. If this is not so, the value of R3 should be adjusted accordingly. Similarly, the value of R1 may need to be adjusted to ensure that the voltage at the emitters of TR2/TR3 is at the mid-supply level, thus ensuring maximum undistorted output.

Virtually all power amplifier integrated circuits operate in a similar manner, although these often include extra circuitry which sets the quiescent current and output voltage automatically, as well as providing protection from over-temperature and short-circuit loads. This was considered unnecessary in this circuit as these conditions are unlikely to occur and the transistors run cool even with prolonged use at maximum output.

CONSTRUCTION

The circuit is built on a piece of stripboard, 18 holes by 9 strips, which

COMPONENTS

Resistors

R1	470k
R2	1k
R3	390Ω

Potentiometer

VR1	10k min. skeleton preset (or panel mounting rotary, log, plus knob, see text)
-----	---

Capacitors

C1	100n ceramic disc, 5mm pitch
C2, C3	100μ radial elect. 16V (2 off)

Semiconductors

TR1, TR2	2N3904 <i>nnp</i> transistor (2 off)
TR3	BC558 <i>pnp</i> transistor

Miscellaneous

LS1	8Ω min. loudspeaker
-----	---------------------

Stripboard, 18 holes x 9 strips; PP3 battery and clip; case to suit; connecting wire; solder, etc.

See
**SHOP
TALK**
page

Approx. Cost
Guidance Only

£6

excl. case and battery

accommodates all of the components except the loudspeaker, as illustrated in Fig.11. Four breaks are required in the tracks. The two wire links can be made from discarded resistor leads. Note that one of these is fitted underneath preset VR1.

Pinouts for the specified transistors are shown earlier in Fig.6. Ensure that the transistors are correctly inserted, and that the orientation of the electrolytic capacitors is correctly followed.

Potentiometer VR1 is specified as a pre-set type, but this could be changed to a panel mounted equivalent if preferred, in which case use a logarithmic type. Panel mounting types are also available with on/off switches, which would save having a separate power switch.

The circuit should not require any adjustment but for maximum undistorted output, the value of R1 may need to be adjusted to ensure that the no-signal voltage at the emitters of TR2/TR3 is exactly at 4.5 volts.

NEXT MONTH

In the next issue a simple metal detector and a timer circuit are described, again using just three transistors.



EPE BINDERS

KEEP YOUR MAGAZINES SAFE – RING US NOW!

This ring binder uses a special system to allow the issues to be easily removed and re-inserted without any damage. A nylon strip slips over each issue and this passes over the four rings in the binder, thus holding the magazine in place.

The binders are finished in hard-wearing royal blue p.v.c. with the magazine logo in gold on the spine. They will keep your issues neat and tidy but allow you to remove them for use easily.

The price is £5.95 plus £3.50 post and packing. If you order more than one binder add £1 postage for each binder after the initial £3.50 postage charge (overseas readers the postage is £6.00 each to everywhere except Australia and Papua New Guinea which costs £10.50 each).

Send your payment in £'s sterling cheque or PO (Overseas readers send £ sterling bank draft, or cheque drawn on a UK bank or pay by card), to **Everyday Practical Electronics, Wimborne Publishing Ltd, 408 Wimborne Road East, Ferndown, Dorset BH22 9ND. Tel: 01202 873872.**

Fax: 01202 874562.

E-mail: editorial@epemag.wimborne.co.uk Web site: <http://www.epemag.wimborne.co.uk>

Order on-line from www.epemag.wimborne.co.uk/shopdoor.htm



We also accept card payments. Mastercard, Visa, Amex, Diners Club or Switch (minimum card order £5). Send your card number, card expiry date and Card Security Code (the last three digits on or just below the signature strip) plus Switch Issue No. with your order.



Hotspots to the Rescue

FOR all the noise the government has made about its Broadband Britain strategy, many people feel short-changed. Living outside cable modem coverage and away from ADSL-enabled telephone exchanges, the way to the information superhighway for them is blocked. The satellite alternative is totally uneconomic too, meaning they're stuck with the information bridleway of 56kbit/s modem dial-up connections.

It is no wonder then that they feel stymied. But there is an alternative and a growing number of techies, radio hams and others committed to telecommunications freedom have decided they can wait no longer. They are creating local wireless networks of their own to cover the places that the big boys just don't reach. And if that all sounds too much like idealism or the early days of bulletin board systems all over again, well perhaps it is but the people involved seem to have a pretty clear focus on what they intend to achieve.

HIGH IDEALS

The WLAN UK organisation (www.wlan.org.uk) has been promoting not-for-profit wireless LANS since 1998. Its contention is that licence-exempt wireless LANS (WLANs) could make it possible to develop amateur and community LANs to serve areas not wired by existing broadband major carriers. These "social" networks would be owned and managed by the local community to offer completely profit-free broadband internet access together with internet-based radio, television, telephone and video communications.

All this would be delivered via a local small community owned co-operative, business or club. The concept builds out from the public access wireless hotspots being established at railway stations, airports, exhibition halls and motorway service areas in the UK by BT and others. For that matter, it is not too far distant from what Starbucks is intending to do in the USA, where the Seattle-based coffee company has already equipped 1,200 of its retail coffee shops for wireless internet access with 2,000 cafes scheduled to have been connected by the end of 2002.

CAN IT WORK?

For Starbucks, BT and others the business model is obvious, whereas for the philanthropic geeks and armchair anarchists (as *The Guardian* so colourfully termed them) the motivation is largely altruistic. On the WLAN UK website Henry O'Tani describes an ingenious scheme in which freenets constructed by community trusts can cover their cost and earn money for established ISPs.

He asserts there that "Initial studies show that our not-for-profit ethic can deliver end user connections for seven per cent of the existing commercial costs. Being provided at its true low cost, wireless broadband community internet can reduce our dependence on the remote decisions of commercial companies as well as bringing broadband to communities that cannot or will not be reached by cable or DSL services."

At the last count there were already 56 nodes in operation across Britain, with 80 in test mode and a further 431 proposed. Not one of them could legally serve third party users, however, and for both the altruists and the anarchists the legal message is the same. In October 2001, however, Douglas Alexander, then minister for e-commerce, launched a consultation for wider use of radio bands to unlicensed commercial services. The legalisation of free community internet access systems is one potential outcome and a decision on this is expected shortly.

HOT STUFF

All this proves that there is considerable interest in freenets for local communities and they could soon be as hot a topic as wireless hotspots are currently. The two are closely related, as wireless evangelist and licensed radio amateur Henry O'Tani explains.

"Since originating the concept in 1998 I have been promoting it passionately world-wide to many organisations. The 'hot' in the term hotspot originated from my initials and from the red roundel on the website. Instead of promoting the idea at commercial trade shows and through normal publicity channels, I chose amateur radio people to spread the word because these are some of the best practical engineers in the world. They have strong fraternal instincts and already understand the key basic concepts of not-for-profit operation and community-focussed services."

With the notion spreading all round the world, he expects that before long the practice will become so well entrenched that the authorities will acknowledge its merit and ratify freenets, in the same way as citizens' band radio became legalised in Europe.

He continues: "I developed early on an email exchange with BT's last chief technologist Peter Cochrane (G3RVC), who predicted that community WLAN would be like CB radio. I have met the BT hotspot people and am now in dialogue with BT over my DX-WLAN patents as a way of extending their market position in mobile communications. Using my DX-WLAN technologies offers about $\times 10$ range for omni-directional services and $\times 30$ for dishes up to 1200mm (4ft) diameter, reducing deployment costs by 99 per

cent or more). Beyond this, 802.11b (11Mbit/s) and 802.11a (54Mbit/s) might make other radio delivery techniques obsolete and solve the old 'delivery paradigm' that cable and telephones have imposed themselves."

If new legislation does allow not-for-profit operations of this kind it will certainly let BT and the cablecom operators off the hook, throwing bypassed communities the initiative to provide their own systems. If they fail to react, the blame will be entirely theirs, having had the opportunity. There's a precedent for this too; communities not served at all by television broadcasters were given the right some years back to institute self-help schemes to pipe signals into their local "black holes".

CARRIERS QUAKING?

For as long as freenets are constructed from Pringles boxes, Sarah Lee pie cans and hobby shop components, it's unlikely that the established carriers and ISPs will be quaking in their boots. But even if these information bridlepaths spread out to cover homes, pavements and parks across all areas currently unserved by cable or DSL, the incumbent operators can only benefit.

As Henry O'Tani convincingly argues, existing internet access and service providers earn real minute by minute revenues from day one, whilst the telcos will still make money by providing the broadband access pipes to the community headends. The benefits to existing ISPs are sufficient to justify investing millions in grants and subsidies to user groups wanting to set up community WLANs and able to meet simple eligibility criteria.

Whether this will actually happen only time will tell but it is entirely feasible and not altogether unlikely once government sees the advantages. A year ago the chances for open-access public wireless hotspots being legalised looked worse than the proverbial snowflake in hell, yet they happened almost overnight thanks to commercial pressure. With a following wind, people could just do the same for freenets.

SIMMERING REBELS

The last word goes to O'Tani, who argues that the movement's success is inevitable. "The debate has started but it's not just about technology. There's a simmering rebellious popular element waiting to explode that makes the WLAN movement similar to the petrol price revolt, illegal CB radio, pirate broadcasting and illicit rave parties. The cost of communications is a grossly inflated 'unearned tax' on every aspect of commerce, government, society and community – and should cost no more than keeping a bicycle."

INTERFACE

Robert Penfold



DIRECT CONTROL OF PC SERIAL LINES USING MSCOMM

There seems to be an ever growing list of "golden oldie" components that have been regularly used in home constructor projects, but are no longer manufactured. The 6402 UART now seems to have joined this group, as do the various equivalents and near equivalent chips that were in plentiful supply not so long ago.

These chips may turn up on the surplus market from time to time, and many constructors probably have one or two in their spares box. However, these chips are now non-starters for new designs. Unfortunately, there seems to be nothing directly comparable that is still available.

A Serial Problem

This is not to say that serial interfacing to a PC is no longer possible. PIC microcontrollers can be programmed to provide serial-to-parallel and (or) parallel-to-serial conversion. Many of the more recent PIC chips also have a built-in UART that will handle all the encoding and decoding, making matters much easier.

Using PIC microcontrollers for serial interfacing has been covered in *EPE* in the past. It is worth looking through some back issues if you are interested in this approach.

There are still serial interfacing chips available, but these go well beyond the basic interfacing capabilities of UARTs such as the 6402. This is fine if you require the facilities of these devices, but they are otherwise rather expensive. Building your own UART from individual logic integrated circuits is no doubt possible, but is not a particularly neat or easy solution.

The upmarket serial devices are probably the only viable approach for those not wishing to take the PIC approach. This is a subject that will be considered in a later *Interface* article.

Handshake Lines

From time to time readers query the possibility of using the handshake lines of the serial ports as general purpose digital inputs and outputs. One way of doing this is to directly control the PC's serial interface chip, and the serial chip registers have been covered previously.

Experience suggests that this is not always successful, and the problem is possibly due to the operating system responding to changes made to the chip's setting. Another approach is to use the facilities of a high level programming language, but the facilities on offer seem to vary somewhat from one language to another.

Direct Control

One of the more upmarket versions of Delphi seems to be a popular choice for

this sort of thing, but Visual BASIC has some ability to use the control lines with the aid of the MSComm control. An advantage of this method is that it will work with any version of Windows, including Windows XP, without the need for third-party add-ons.

Direct control of two handshake outputs is possible, and the DTR line will be considered first. This is controlled via the DTREnable facility of the MSComm control.

If the serial port is switched off, the DTR line goes to about -12V regardless of the DTREnable setting. If DTREnable is set to True, the DTR line goes to about +12V when the port is switched on. Apparently the basic idea is to normally have DTREnable set to True so that the DTR line automatically goes to -12V when the port is switched off. In a modem application this results in the telephone automatically hanging up when the port is disabled. However, with the port switched on the DTR line can be forced to the -12V state by setting DTREnable to False. In other words, provided the port is switched on, the DTR line can be set to +12V or -12V by setting DTREnable to True and False respectively.

Provided a version of Visual BASIC that has MSComm is available it is quite easy to try out controlling the DTR line. The DTR terminal is at pin 4 of a 9-pin serial port or pin 20 of a 25-pin type (see Fig.1).

Do not use a logic tester to monitor the DTR line unless it is a type that can safely

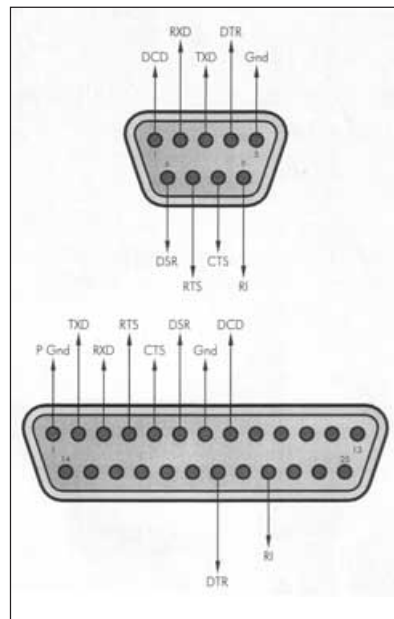

Fig.1. Connection details for 9-pin and 25-pin serial ports.

handle the relatively high positive and negative voltages produced by an RS232C serial port. A digital multimeter set to a suitable d.c. voltage range is the best option, as it will register positive and negative voltages without having to swap over the test prods.

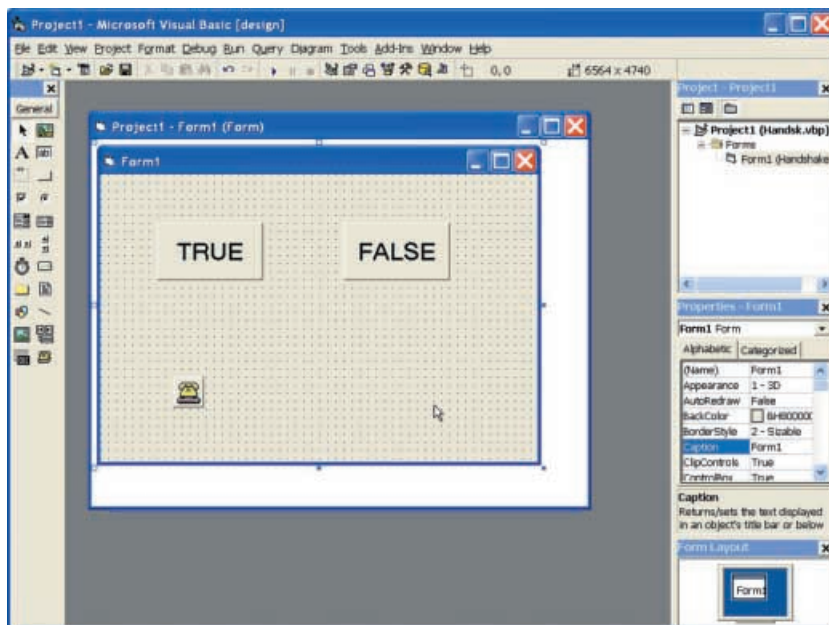

Fig.2. Screen dump of the command buttons on the VB form required for the test routine.

Test Software

In order to test control of the DTR line, add two command buttons to a form in Visual BASIC. Also add the MSCOMM ActiveX control. Change the caption of Command1 to "True" and Command2 to "False".

This should give something like the screen shot shown in Fig.2. Next add these few lines of code in the Code window:

```
Private Sub Command1_Click()  
MSComm1.DTREnable = True  
End Sub
```

```
Private Sub Command2_Click()  
MSComm1.DTREnable = False  
End Sub
```

```
Private Sub Form_Load()  
MSComm1.PortOpen = True  
End Sub
```

The subroutine for Command1 sets DTREnable to True when the button is operated, and the subroutine for Command2 sets it to False when that button is operated. If everything is working properly, operating Command1 will set DTR to about +12V, and operating Command2 will set it to about -12V.

The subroutine for the form simply switches on the relevant serial port. Although no data is being sent or received by the serial port, control of the DTR line will only work properly with the port enabled.

Serial port 1 (Com1) is used by default, but port 2 can be used instead by selecting MSComm1 and setting CommPort 2 using the Object Inspector. Most of the other settings are of no consequence as no data is being output on the TX Data output.

One exception is the DTREnable setting, which enables the initial state of the DTR line to be set. Presumably this can also be achieved by using the appropriate code in the subroutine for the Form.

RTS Output

In a similar vein to DTREnable facility, the RTS output is controlled by the RTSEnable instruction. Some descriptions of this instruction suggest that this line can only be controlled by switching the port on and off. However, in practice it seems to work in identical fashion to the DTREnable instruction.

Provided the port is switched on, setting RTSEnable to True sends the RTS line to +12V, and setting it to False sends the RTS line to -12V. Modifying the subroutines for the two command buttons, as shown below, therefore results in the program controlling the RTS line.

```
Private Sub Command1_Click()  
MSComm1.RTSEnable = True  
End Sub
```

```
Private Sub Command2_Click()  
MSComm1.RTSEnable = False  
End Sub
```

Handshake Inputs

MSCOMM can be used to read some of the handshake inputs, but only in an indirect fashion. The OnComm facility of MSCOMM can be used to generate an event each time the relevant handshake input changes state. These are the four events generated by handshake inputs:

Setting	Value	Description
ComEvCTS	3	Change in the state of CTS line
ComEvDSR	4	Change in the state of DSR line
ComEvCD	5	Change in the state of CD line
ComEvRing	6	Ring detected

According to some sources, only changes from high to low on the DSR line are detected. Practical experiments suggest that this is not the case. "Ring detected" presumably means that the relevant state on the RI (Ring Indicator) line has been detected.

A simple way of trying out a handshake input is to extend the original test program by first adding a label to the form. Set a reasonably large font and change the label's caption to "0". Change the program code so that it looks like this:

```
Private Sub Command1_Click()  
MSComm1.RTSEnable = True  
End Sub
```

```
Private Sub Command2_Click()  
MSComm1.RTSEnable = False  
End Sub
```

```
Private Sub Form_Load()  
MSComm1.PortOpen = True  
End Sub
```

```
Private Sub MSComm1_OnComm()  
If (MSComm1.CommEvent =  
comEvCTS) Then  
Label1.Caption = Label1.Caption + 1  
End If  
End Sub
```

The idea of the program is to toggle the RTS line using the two buttons, and to count the transitions via the CTS handshake input. The CTS and RTS lines are a good choice since they are next to each other on a 9-pin serial port. These two lines can be connected together by using a 9-way female D-connector having pin 7 and pin 8 wired together.

Alternatively, a small crocodile clip can be carefully fitted onto pins 7 and 8 of the serial port, being careful not to make a connection to any other pin. Serial port output lines have current limiting so they will not be damaged by accidental short circuits, but additional connections could prevent the program from working.

All Change

An If . . . Then statement in the subroutine for MSComm1 is used to detect

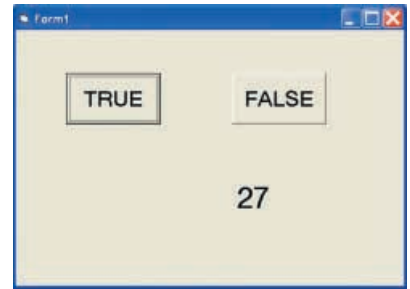

Fig.3. Example of results obtained when using the handshake test routine.

changes on the CTS line and increment the value displayed on the label. Each time a ComEvCTS event occurs the value used for Label1's caption is increased by one. The program performed as expected when it was tried, and Fig.3 shows it in action.

Each of the other handshake inputs can be tested by using the appropriate CommEvent in the program and connecting the RTS line to the correct input of the serial port. Using ComEvCD with the DCD input provides the same action as using the CTS input, with each transition being counted. The same is true when the DSR input is used.

As pointed out previously, some sources suggest that only high to low transitions of this line produce an event, but this seems to be an error. With this program the count is increment each time the RTS line changes state.

However, using the ComEvRing event and the RI input does result in only the high to low transitions being counted. Alternately operating the two buttons only produces an increment in the count when the False button is operated.

In a modem application the RI input presumably goes low when the ring is detected, and MSComm is only designed to detect this event. In many practical applications it is only necessary to detect one type of transition, so this is not really a major drawback. In some cases it could make things easier.

Two digital outputs and four edge counting inputs does not give great scope for interfacing gadgets to a PC. On the other hand, it is adequate for many simple applications such as pulse counting and motor control. This method certainly represents a viable alternative to parallel port interfacing for many applications that only require a few inputs and outputs.

EPE NET ADDRESSES

EPE FTP site: <ftp://ftp.epemag.wimborne.co.uk>

Access the FTP site by typing the above into your web browser, or by setting up an FTP session using appropriate FTP software, then go into quoted sub-directories:

PIC-project source code files: **/pub/PICS**

PIC projects each have their own folder; navigate to the correct folder and open it, then fetch all the files contained within. *Do not try to download the folder itself!*

EPE text files: **/pub/docs**

Basic Soldering Guide: **solder.txt**

Ingenuity Unlimited submission guidance: **ing_unlit.txt**

New readers and subscribers info: **epe_info.txt**

Newsgroups or Usenet users advice: **usenet.txt**

Ni-Cad discussion: **nicadfaq.zip** and **nicad2.zip**

Writing for EPE advice: **write4us.txt**

You can also enter the FTP site via the link at the top of the main page of our home site at:

<http://www.epemag.wimborne.co.uk>

Shop now on-line: www.epemag.wimborne.co.uk/shopdoor.htm

EPE IS PLEASED TO BE ABLE TO OFFER YOU THESE ELECTRONICS CD-ROMS

ELECTRONICS PROJECTS

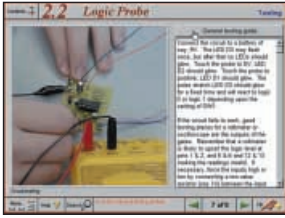

Logic Probe testing

Electronic Projects is split into two main sections: **Building Electronic Projects** contains comprehensive information about the components, tools and techniques used in developing projects from initial concept through to final circuit board production. Extensive use is made of video presentations showing soldering and construction techniques. The second section contains a set of ten projects for students to build, ranging from simple sensor circuits through to power amplifiers. A shareware version of Matrix's CADPACK schematic capture, circuit simulation and p.c.b. design software is included.

The projects on the CD-ROM are: Logic Probe; Light, Heat and Moisture Sensor; NE555 Timer; Egg Timer; Dice Machine; Bike Alarm; Stereo Mixer; Power Amplifier; Sound Activated Switch; Reaction Tester. Full parts lists, schematics and p.c.b. layouts are included on the CD-ROM.

ELECTRONICS CAD PACK

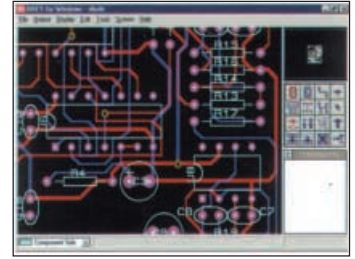

PCB Layout

Electronics CADPACK allows users to design complex circuit schematics, to view circuit animations using a unique SPICE-based simulation tool, and to design printed circuit boards. CADPACK is made up of three separate software modules. (These are restricted versions of the full Labcenter software.) **ISIS Lite** which provides full schematic drawing features including full control of drawing appearance, automatic wire routing, and over 6,000 parts. **PROSPICE Lite** (integrated into ISIS Lite) which uses unique animation to show the operation of any circuit with mouse-operated switches, pots, etc. The animation is compiled using a full mixed mode SPICE simulator. **ARES Lite** PCB layout software allows professional quality PCBs to be designed and includes advanced features such as 16-layer boards, SMT components, and an autorouter operating on user generated Net Lists.

ELECTRONIC CIRCUITS & COMPONENTS V2.0

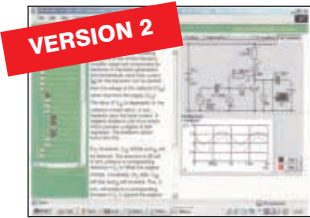

Circuit simulation screen

Provides an introduction to the principles and application of the most common types of electronic components and shows how they are used to form complete circuits. The virtual laboratories, worked examples and pre-designed circuits allow students to learn, experiment and check their understanding. Version 2 has been considerably expanded in almost every area following a review of major syllabuses (GCSE, GNVQ, A level and HNC). It also contains both European and American circuit symbols. Sections include: **Fundamentals**: units & multiples, electricity, electric circuits, alternating circuits. **Passive Components**: resistors, capacitors, inductors, transformers. **Semiconductors**: diodes, transistors, op.amps, logic gates. **Passive Circuits. Active Circuits. The Parts Gallery** will help students to recognise common electronic components and their corresponding symbols in circuit diagrams. Included in the Institutional Versions are multiple choice questions, exam style questions, fault finding virtual laboratories and investigations/worksheets.

ANALOGUE ELECTRONICS

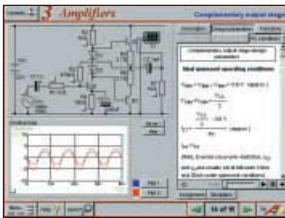

Complimentary output stage

Analogue Electronics is a complete learning resource for this most difficult branch of electronics. The CD-ROM includes a host of virtual laboratories, animations, diagrams, photographs and text as well as a SPICE electronic circuit simulator with over 50 pre-designed circuits.

Sections on the CD-ROM include: **Fundamentals** – Analogue Signals (5 sections), Transistors (4 sections), Waveshaping Circuits (6 sections). **Op.Amps** – 17 sections covering everything from Symbols and Signal Connections to Differentiators. **Amplifiers** – Single Stage Amplifiers (8 sections), Multi-stage Amplifiers (3 sections). **Filters** – Passive Filters (10 sections), Phase Shifting Networks (4 sections), Active Filters (6 sections). **Oscillators** – 6 sections from Positive Feedback to Crystal Oscillators. **Systems** – 12 sections from Audio Pre-Amplifiers to 8-Bit ADC plus a gallery showing representative p.c.b. photos.

DIGITAL ELECTRONICS V2.0

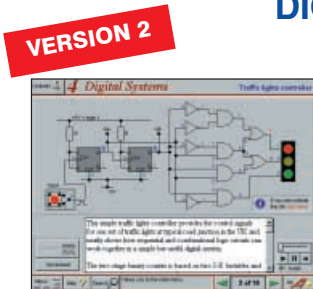

Virtual laboratory – Traffic Lights

Digital Electronics builds on the knowledge of logic gates covered in *Electronic Circuits & Components* (opposite), and takes users through the subject of digital electronics up to the operation and architecture of microprocessors. The virtual laboratories allow users to operate many circuits on screen. Covers binary and hexadecimal numbering systems, ASCII, basic logic gates, monostable action and circuits, and bistables – including JK and D-type flip-flops. Multiple gate circuits, equivalent logic functions and specialised logic functions. Introduces sequential logic including clocks and clock circuitry, counters, binary coded decimal and shift registers. A/D and D/A converters, traffic light controllers, memories and microprocessors – architecture, bus systems and their arithmetic logic units. Sections on Boolean Logic and Venn diagrams, displays and chip types have been expanded in Version 2 and new sections include shift registers, digital fault finding, programmable logic controllers, and microcontrollers and microprocessors. The Institutional versions now also include several types of assessment for supervisors, including worksheets, multiple choice tests, fault finding exercises and examination questions.

FILTERS

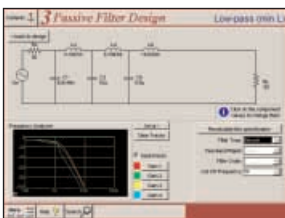

Filter synthesis

Filters is a complete course in designing active and passive filters that makes use of highly interactive virtual laboratories and simulations to explain how filters are designed. It is split into five chapters: **Revision** which provides underpinning knowledge required for those who need to design filters. **Filter Basics** which is a course in terminology and filter characterization, important classes of filter, filter order, filter impedance and impedance matching, and effects of different filter types. **Advanced Theory** which covers the use of filter tables, mathematics behind filter design, and an explanation of the design of active filters. **Passive Filter Design** which includes an expert system and filter synthesis tool for the design of low-pass, high-pass, band-pass, and band-stop Bessel, Butterworth and Chebyshev ladder filters. **Active Filter Design** which includes an expert system and filter synthesis tool for the design of low-pass, high-pass, band-pass, and band-stop Bessel, Butterworth and Chebyshev op.amp filters.

ROBOTICS & MECHATRONICS



Case study of the Milford Instruments Spider

Robotics and Mechatronics is designed to enable hobbyists/students with little previous experience of electronics to design and build electromechanical systems. The CD-ROM deals with all aspects of robotics from the control systems used, the transducers available, motors/actuators and the circuits to drive them. Case study material (including the NASA Mars Rover, the Milford Spider and the Furby) is used to show how practical robotic systems are designed. The result is a highly stimulating resource that will make learning, and building robotics and mechatronic systems easier. The Institutional versions have additional worksheets and multiple choice questions.

- Interactive Virtual Laboratories
- Little previous knowledge required
- Mathematics is kept to a minimum and all calculations are explained
- Clear circuit simulations

PRICES

Prices for each of the CD-ROMs above are:

(Order form on third page)

Hobbyist/Student	£45 inc VAT
Institutional (Schools/HE/FE/Industry).....	£99 plus VAT
Institutional 10 user (Network Licence)	£199 plus VAT
Site Licence.....	£499 plus VAT

(UK and EU customers add VAT at 17.5% to "plus VAT" prices)

PICmicro TUTORIALS AND PROGRAMMING

HARDWARE

VERSION 2 PICmicro MCU DEVELOPMENT BOARD

Suitable for use with the three software packages listed below.

This flexible development board allows students to learn both how to program PICmicro microcontrollers as well as program a range of 8, 18, 28 and 40-pin devices. For experienced programmers all programming software is included in the PPP utility that comes with the development board. For those who want to learn, choose one or all of the packages below to use with the Development Board.

- Makes it easier to develop PICmicro projects
- Supports low cost Flash-programmable PICmicro devices
- Fully featured integrated displays – 13 individual I.e.d.s, quad 7-segment display and alphanumeric I.c.d. display
- Supports PICmicro microcontrollers with A/D converters
- Fully protected expansion bus for project work
- All inputs and outputs available on screw terminal connectors for easy connection

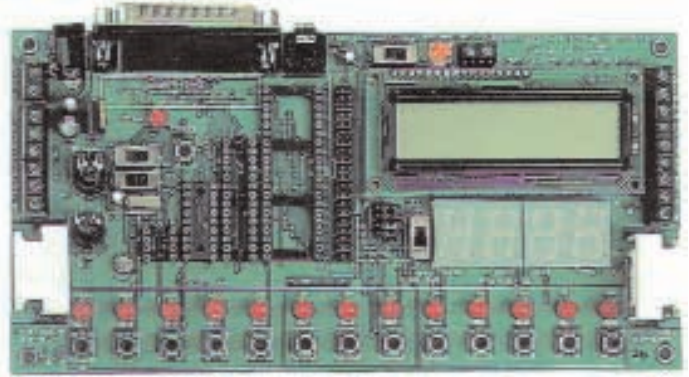

£145 including VAT and postage
12V 500mA plug-top PSU (UK plug) £7
25-way 'D' type connecting cable £5

SOFTWARE

Suitable for use with the Development Board shown above.

ASSEMBLY FOR PICmicro V2 (Formerly PICtutor)

Assembly for PICmicro microcontrollers V2.0 (previously known as PICtutor) by John Becker contains a complete course in programming the PIC16F84 PICmicro microcontroller from Arizona Microchip. It starts with fundamental concepts and extends up to complex programs including watchdog timers, interrupts and sleep modes. The CD makes use of the latest simulation techniques which provide a superb tool for learning: the Virtual PICmicro microcontroller. This is a simulation tool that allows users to write and execute MPASM assembler code for the PIC16F84 microcontroller on-screen. Using this you can actually see what happens inside the PICmicro MCU as each instruction is executed which enhances understanding.

- Comprehensive instruction through 39 tutorial sections
- Includes Vlab, a Virtual PICmicro microcontroller: a fully functioning simulator
- Tests, exercises and projects covering a wide range of PICmicro MCU applications
- Includes MPLAB assembler
- Visual representation of a PICmicro showing architecture and functions
- Expert system for code entry helps first time users
- Shows data flow and fetch execute cycle and has challenges (washing machine, lift, crossroads etc.)
- Imports MPASM files.



Virtual PICmicro

'C' FOR PICmicro VERSION 2

The C for PICmicro microcontrollers CD-ROM is designed for students and professionals who need to learn how to program embedded microcontrollers in C. The CD contains a course as well as all the software tools needed to create Hex code for a wide range of PICmicro devices – including a full C compiler for a wide range of PICmicro devices.

Although the course focuses on the use of the PICmicro microcontrollers, this CD-ROM will provide a good grounding in C programming for any microcontroller.

- Complete course in C as well as C programming for PICmicro microcontrollers
- Highly interactive course
- Virtual C PICmicro improves understanding
- Includes a C compiler for a wide range of PICmicro devices
- Includes full Integrated Development Environment
- Includes MPLAB software
- Compatible with most PICmicro programmers
- Includes a compiler for all the PICmicro devices.

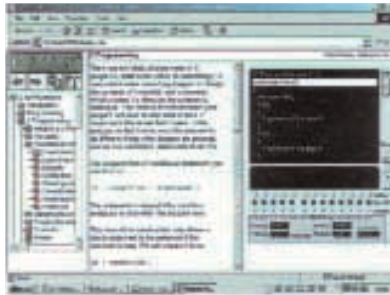

Minimum system requirements for these items: Pentium PC running Windows 98, NT, 2000, ME, XP; CD-ROM drive; 64MB RAM; 10MB hard disk space.

FLOWCODE FOR PICmicro

Flowcode is a very high level language programming system for PICmicro microcontrollers based on flowcharts. Flowcode allows you to design and simulate complex robotics and control systems in a matter of minutes.

Flowcode is a powerful language that uses macros to facilitate the control of complex devices like 7-segment displays, motor controllers and I.c.d. displays. The use of macros allows you to control these electronic devices without getting bogged down in understanding the programming involved.

Flowcode produces MPASM code which is compatible with virtually all PICmicro programmers. When used in conjunction with the Version 2 development board this provides a seamless solution that allows you to program chips in minutes.

- Requires no programming experience
- Allows complex PICmicro applications to be designed quickly
- Uses international standard flow chart symbols (ISO5807)
- Full on-screen simulation allows debugging and speeds up the development process
- Facilitates learning via a full suite of demonstration tutorials
- Produces ASM code for a range of 8, 18, 28 and 40-pin devices
- Institutional versions include virtual systems (burglar alarms, car parks etc.).



Burglar Alarm Simulation

PRICES

Prices for each of the CD-ROMs above are:

(Order form on next page)

(UK and EU customers add VAT at 17.5% to "plus VAT" prices)

Hobbyist/Student
Institutional (Schools/HE/FE/Industry)
Flowcode Institutional
Institutional 10 user (Network Licence)
Site Licence

£45 inc VAT
£99 plus VAT
£70 plus VAT
£249 plus VAT
£599 plus VAT

TEACH-IN 2000 – LEARN ELECTRONICS WITH EPE

EPE's own *Teach-In* CD-ROM, contains the full 12-part *Teach-In* series by John Becker in PDF form plus the *Teach-In* interactive software covering all aspects of the series. We have also added Alan Winstanley's highly acclaimed *Basic Soldering Guide* which is fully illustrated and which also includes *Desoldering*. The *Teach-In* series covers: Colour Codes and Resistors, Capacitors, Potentiometers, Sensor Resistors, Ohm's Law, Diodes and L.E.D.s, Waveforms, Frequency and Time, Logic Gates, Binary and Hex Logic, Op.amps, Comparators, Mixers, Audio and Sensor Amplifiers, Transistors, Transformers and Rectifiers, Voltage Regulation, Integration, Differentiation, 7-segment Displays, L.C.D.s, Digital-to-Analogue.

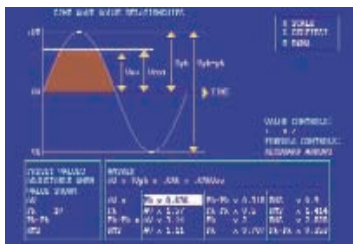

Sine wave relationship values

Each part has an associated practical section and the series includes a simple PC interface so you can use your PC as a basic oscilloscope with the various circuits.

A hands-on approach to electronics with numerous breadboard circuits to try out.

£12.45 including VAT and postage. Requires Adobe Acrobat (available free from the Internet – www.adobe.com/acrobat).

FREE WITH EACH TEACH-IN CD-ROM – *Electronics Hobbyist Compendium* 80-page book by Robert Penfold. Covers Tools For The Job; Component Testing; Oscilloscope Basics.

FREE BOOK WITH TEACH-IN 2000 CD-ROM

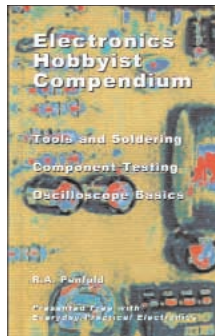

DIGITAL WORKS 3.0

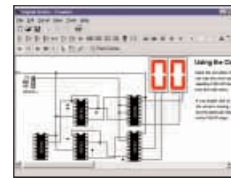

Counter project

Digital Works Version 3.0 is a graphical design tool that enables you to construct digital logic circuits and analyze their behaviour. It is so simple to use that it will take you less than 10 minutes to make your first digital design. It is so powerful that you will never outgrow its capability ● Software for simulating digital logic circuits ● Create your own macros – highly scalable ● Create your own circuits, components, and i.c.s ● Easy-to-use digital interface ● Animation brings circuits to life ● Vast library of logic macros and 74 series i.c.s with data sheets ● Powerful tool for designing and learning.

Hobbyist/Student £45 inc. VAT. Institutional £99 plus VAT. Institutional 10 user £199 plus VAT. Site Licence £499 plus VAT.

ELECTRONICS IN CONTROL

Two colourful animated courses for students on one CD-ROM. These cover Key Stage 3 and GCSE syllabuses. **Key Stage 3:** A pictorial look at the Electronics section featuring animations and video clips. Provides an ideal introduction or revision guide, including multi-choice questions with feedback. **GCSE:** Aimed at the Electronics in many Design & Technology courses, it covers many sections of GCSE Electronics. Provides an ideal revision guide with Homework Questions on each chapter. Worked answers with an access code are provided on a special website.

Single User £29 inc. VAT. Multiple User £39 plus VAT
Student copies (available only with a multiple user copy) £6 plus VAT
(UK and EU customers add VAT at 17.5% to "plus VAT" prices)

MODULAR CIRCUIT DESIGN

Contains a range of tried and tested analogue and digital circuit modules, together with the knowledge to use and interface them. Thus allowing anyone with a basic understanding of circuit symbols to design and build their own projects. Version 3 includes data and circuit modules for a range of popular PICs; includes PICAXE circuits, the system which enables a PIC to be programmed without a programmer, and without removing it from the circuit. Shows where to obtain free software downloads to enable BASIC programming. Essential information for anyone undertaking GCSE or "A" level electronics or technology and for hobbyists who want to get to grips with project design. Over seventy different Input, Processor and Output modules are illustrated and fully described, together with detailed information on construction, fault finding and components, including circuit symbols, pinouts, power supplies, decoupling etc.

Single User £19.95 inc. VAT. Multiple User £34 plus VAT
(UK and EU customers add VAT at 17.5% to "plus VAT" prices)

VERSION 3

ELECTRONIC COMPONENTS PHOTOS

A high quality selection of over 200 JPG images of electronic components. This selection of high resolution photos can be used to enhance projects and presentations or to help with training and educational material. They are royalty free for use in commercial or personal printed projects, and can also be used royalty free in books, catalogues, magazine articles as well as worldwide web pages (subject to restrictions – see licence for full details).



Also contains a **FREE** 30-day evaluation of Paint Shop Pro 6 – Paint Shop Pro image editing tips and on-line help included!

Price £19.95 inc. VAT

Minimum system requirements for these CD-ROMs: Pentium PC, CD-ROM drive, 32MB RAM, 10MB hard disk space. Windows 95/98/NT/2000/ME/XP, mouse, sound card, web browser.

Please send me:

CD-ROM ORDER FORM

- Electronic Projects
- Electronic Circuits & Components V2.0
- Analogue Electronics
- Digital Electronics V2.0
- Filters
- Electronics CAD Pack
- Robotics & Mechatronics
- Assembler for PICmicro
- 'C' for PICmicro
- Flowcode for PICmicro
- Digital Works 3.0

Version required:

- Hobbyist/Student
- Institutional
- Institutional 10 user
- Site licence



- PICmicro Development Board (hardware)
- Development Board UK plugtop power supply
- Development Board 25-way connecting lead

- Teach-In 2000 + FREE BOOK
- Electronic Components Photos
- Electronics In Control – Single User
- Electronics In Control – Multiple User
- Modular Circuit Design – Single User
- Modular Circuit Design – Multiple User

Note: The software on each version is the same, only the licence for use varies.

Full name:

Address:

.....Post code:Tel. No:

Signature:

I enclose cheque/PO in £ sterling payable to WIMBORNE PUBLISHING LTD for £

Please charge my Visa/Mastercard/Amex/Diners Club/Switch: £Card expiry date:

Card No:Switch Issue No.

Card Security Code (The last 3 digits on or just under the signature strip)

ORDERING

ALL PRICES INCLUDE UK POSTAGE

Student/Single User/Standard Version price includes postage to most countries in the world
EU residents outside the UK add £5 for airmail postage per order

Institutional, Multiple User and Deluxe Versions – overseas readers add £5 to the basic price of each order for airmail postage (do not add VAT unless you live in an EU (European Union) country, then add 17½% VAT or provide your official VAT registration number).

Send your order to:
Direct Book Service
Wimborne Publishing Ltd
408 Wimborne Road East
Ferndown, Dorset BH22 9ND

To order by phone ring

01202 873872. Fax: 01202 874562

Goods are normally sent within seven days

E-mail: orders@wimborne.co.uk

Online shop:
www.epemag.wimborne.co.uk/shopdoor.htm

TESLA HIGH VOLTAGE TRANSFORMER

RAYMOND HAIGH

Spectacularly create sizzling DIY lightning!

THIS small assembly gives a sizzling demonstration of Nikola Tesla's most famous discovery, a high frequency, high voltage transformer. The design presented here is much safer to adjust and operate than larger versions, and all of the materials and parts are widely available.

BRIEF HISTORY

Born in Croatia in 1856, Tesla emigrated to America in 1884 where he was largely responsible for the introduction of alternating current power generation and distribution; the system which is now adopted world wide. Although this was his major engineering achievement, he is more popularly known for his transformer, which he invented in 1891.

Tesla ridiculed the electro-magnetic theory of radio wave propagation, insisting that transmission is due to conduction through the earth. His vision was to erect a network of huge, high voltage transformers, which would deliver telegraph signals and electrical power to any number of remote receiving stations, using the earth as the conducting medium.

He began the construction of a prototype station at Wardencllyffe, Long Island, in 1901, the year Marconi first transmitted radio signals across the Atlantic. By 1903, financial difficulties had forced him to abandon the project when it was well advanced. Marconi's success had no doubt made it difficult for Tesla to attract backers for his untried system, despite his enormous prestige as an engineer.

Creditors eventually pursued him through the US Supreme Court, and the decaying 200 feet tall transformer tower, which he called a "magnifying transmitter", together with the ancillary buildings, were demolished in 1917.

DREAM MACHINE

Tesla held on to his dream, refusing to accept that radio signals are propagated by electro-magnetic waves. His ideas,

published in the press and technical journals, became increasingly bizarre, and included death-ray machines (again using his high voltage transformer) and thought photography. He died in New York in 1943.

Tamed, electronically driven versions of his transformer continue to provide the high voltages needed by cathode ray tubes in TVs and other equipment. They are also used to initiate the arc in industrial welding.

Tesla's invention still excites the interest of experimenters, no doubt because of the dramatic and violent electrical discharges which large versions of the transformer can produce. These big coils are lethal. They can be tricky to get going and have to be adjusted and operated with the utmost care. Moreover, obtaining parts for the energizing primary circuit can prove difficult.

Although the version described here is much smaller, its vicious, hissing discharge is quite impressive. Construction is simpler, the parts and materials are widely available, and it is much less dangerous.

HOW IT WORKS

Tesla's understanding of the magnifying effect of resonant tuned circuits was profound, and he repeatedly stressed the need for tuning and for the sudden excitation of the circuit via a capacitor.

Tuned circuits formed by inductors and capacitors magnify oscillating voltages. The effect depends on the Q (freedom from resistive or dielectric losses) of the inductor and capacitor combination. If one volt is applied to a tuned circuit with a Q of 100, it will be magnified to 100 volts if its frequency of oscillation coincides with the resonant frequency of the tuned circuit.

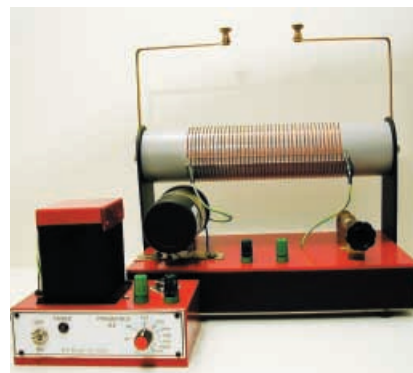

The dramatic performance of Tesla's transformer depends on this phenomenon. His invention pre-dated the amplifying valve, and the only means he had of inducing oscillations in the resonant circuit was by repeatedly shock exciting it (rather like pushing a clock pendulum to keep it swinging). To get the performance he was striving for, the tuned circuit had to be pulsed with large amounts of energy, and he used a spark gap and capacitor combination to achieve this.

BASIC CIRCUIT

The basic circuit for a Tesla Transformer is given in Fig.1, where the transformer primary, L1, is connected across a spark gap via capacitor C1. At switch-on, C1 charges through L1 until the spark gap breakdown voltage is developed across it. When the gap fires, C1 is discharged, very suddenly, through L1, and the process begins again.

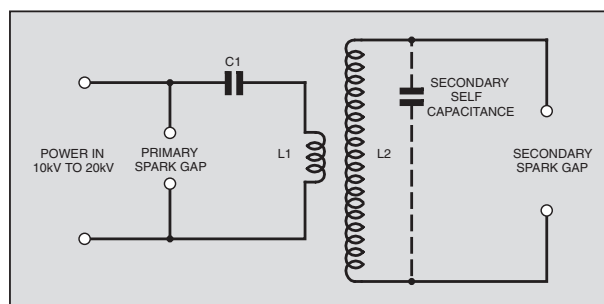

Fig.1. Basic circuit of the Tesla Transformer.

This rapid and repeated dumping of comparatively large pulses of energy into the primary winding induces a voltage in the secondary winding, L2. Shock excitation by steeply rising waveforms makes the voltage oscillate at the secondary coil's resonant frequency, and magnification takes place.

The inductance and self-capacitance of the secondary, L2, determine the frequency of oscillation of the system, which is usually in the region of 150kHz. For best performance, the primary should resonate at the same frequency as the secondary.

TESLA HIGH VOLTAGE TRANSFORMER

DANGER WARNING
Although this small Tesla transformer is not as dangerous as larger models, certain precautions must be strictly observed.

1. The car ignition coil will deliver an extremely unpleasant electric shock. To someone with a weak heart the experience could be life-threatening. Never touch the terminals of the ignition coil, the spark gap electrodes, or the Tesla transformer whilst the power supply is connected. Always disconnect the power supply from the mains before making any adjustments to the Tesla transformer primary tapping.
2. Sparks can cause fires. Always ensure that the unit is operated in a suitable environment.
3. Ultra violet light is emitted by electrical discharges. Prolonged exposure can cause damage to the eyes and skin. Keep a reasonable distance from the equipment whilst it is working. Do not stare at the discharge for long periods.
4. Electrical discharges create ozone, a three-atom oxygen molecule. This is a pungent smelling toxic gas that can cause irritation to the nose and throat. It can also impair lung function in people susceptible to asthma. Always ensure that the unit is operated in a well-ventilated space.
5. When properly adjusted, the secondary of the Tesla transformer will not produce any sensation of electric shock (the voltage is oscillating at a low radio frequency and the human nervous system is insensitive to it). The discharge will, however, burn flesh. Sparks should never be drawn off with the finger. For a similar reason, the face should never be brought near the secondary terminals. A discharge to the eyes would cause severe damage.
6. Electrical discharges cause interference to radio receivers. Fortunately, the transformer and the connections to it do not make a very good radiator at the frequencies involved, and the problem is not as severe as it might otherwise be. Nevertheless, the unit should be operated for short periods and with considerable restraint.
7. The field radiated by the Tesla coil could affect pacemakers and other electronic medical aids. The unit must not be operated in the vicinity of people fitted with these devices, or close to sensitive electronic equipment of any kind.

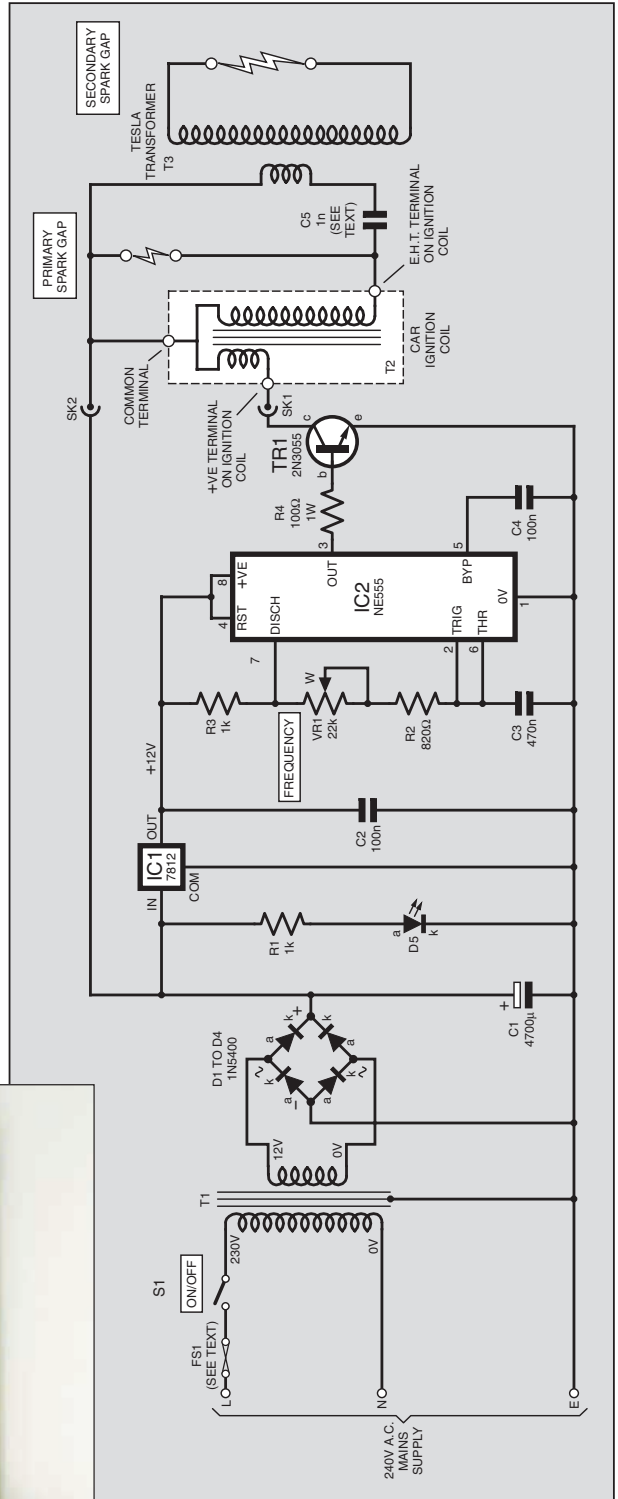

Fig.2. Full circuit diagram for the Tesla High Voltage Transformer.

Readers who have no experience of building or commissioning mains-powered equipment are reminded that the voltages involved can KILL. They must seek the help of an experienced constructor before embarking on this project.

Tuning can be effected by adjusting the value of capacitor C1, and/or the inductance of the primary, L1. The frequency of the energizing voltage (when it is adjustable), and the spark gap setting, have to be optimized to maximize the efficiency of the system.

BRUTE FORCE

Mains transformers capable of delivering 10kV to 15kV at currents of around 0.1A are used by experimenters to power large versions of the coil. The release of this amount of energy excites the system in a way that cannot be duplicated by valves or semiconductors, and enthusiasts still adopt Tesla's basic circuit.

The ability of the energizing voltage to deliver comparatively large currents makes the equipment extremely dangerous to set up and use, and burning of the spark gap electrodes becomes a problem.

BABY TESLA

Compared to the transformer on Long Island, this coil hardly warrants the adjective "baby". The circuit is given in Fig.2.

A car ignition coil, T2, is used to provide the high energizing voltage for the Tesla transformer. These coils have a step-up ratio of no more than 100:1 and depend for their action on the abrupt switching of the voltage applied to the primary.

In a basic (non electronic) car ignition circuit the sudden collapse of the magnetic field when the 12V d.c. supply is interrupted by a cam actuated breaker (the "points") induces an e.m.f. in the primary of around 200V to 250V. Stepping this up 100 times produces the necessary e.h.t.

SWITCHING CIRCUIT

Modern car ignition systems use transistors rather than cam actuated contacts to switch the primary supply on and off, and this technique is adopted here. Power transistor TR1 controls the flow of current through the primary of T2, and the necessary abrupt switching action is provided by IC2, a 555 timer i.c. configured as a square wave generator.

Potentiometer, VR1, together with resistors R2 and R3, and capacitor C3, determine the operating frequency, which can be swept, by VR1, from around 55Hz to 1100Hz. Pin 5 is grounded via C4 to prevent circuit action being disturbed by stray pick-up.

The square wave output, coupled to the base of TR1 via current limiting resistor R4, switches the power transistor, and hence the current through the ignition coil primary, on and off at a rate determined by the setting of VR1.

MAINS POWER SUPPLY

Mains transformer T1, full-wave bridge rectifiers D1 to D4, and reservoir capacitor C1, form the power supply for the system. With a 12V a.c. mains transformer secondary, the output swings from around 17V d.c. under no-load conditions to 14V d.c. when the Tesla transformer is being driven.

The unloaded output exceeds the safe working voltage of IC2, and its supply is, therefore, held at 12V by regulator IC1. Current to the l.e.d. on/off indicator D5 is limited by resistor R1, and capacitor C2 ensures the stability of the regulator.

COMPONENTS

Approx. Cost
Guidance Only

£30
excl. hardware

POWER SUPPLY AND PULSER

Resistors

R1, R3 1k (2 off)
R2 820Ω
R4 100Ω 1W
All 0.25W, 5% except R4.

See
SHOP
TALK
page

Potentiometer

VR1 22k rotary carbon, linear

Capacitors

C1 4700μ axial elect. 35V
C2, C4 100n ceramic disc, 25V (2 off)
C3 470n polyester

Semiconductors

D1 to D4 1N5400 50V 1A rec. diode (4 off)
D5 5mm red l.e.d., with bezel
TR1 2N3055 power transistor (see text)
IC1 7812 +12V 1A voltage regulator
IC2 555 timer

Miscellaneous

T1 mains transformer, 12V secondary 2A min.
S1 s.p.s.t. toggle switch, mains rated, 5A
FS1 fuse 3A max., 1A slow-blow preferred
SK1, SK2 4mm screw terminals, 1 each red and black

Printed circuit board, available from the EPE PCB Service, code 382; fuseholder, panel mounting; 8-pin d.i.l. socket; mica insulating washer and insulated bolts for TR1; heatsink compound; aluminium chassis, 150mm × 100mm × 50mm (6in × 4in × 2in) or larger; control knob; nuts; bolts; washers; solder tags; p.c.b. stand-off supports (4 off); 1mm terminal pins; connecting wire; 3-core mains lead; self adhesive rubber feet (4 off)

HIGH VOLTAGE UNIT

Energizing circuit

T2 car ignition coil (see text)
C5 1n – aluminium cooking foil, 2mm acrylic sheet, masking or insulating tape (see text and Fig.5)

Primary Spark Gap

Control knob; plastic spindle, 60mm × 6mm (2.5in × 1/4in) and spindle bush; brass strip for brackets, 175mm × 19mm × 0.5mm (7in × 3/4in × 1/64in); brass bolts, 25mm × 4mm (1in × 4BA) (2 off) plus nuts and cap nuts to suit; fixing bolts, 13mm × 3mm (0.5in × 6BA) (3 off) plus nuts, washers and solder tags to suit; flexible plastic tubing.

Tesla Transformer

Plastic rain water pipe, 68mm o/d (2.5in i/d) × 305mm (12in); plastic waste pipe, 41mm o/d (1.5in i/d) × 305mm (12in); plastic 35mm film containers or similar (2 off); fixing bolts, 25mm × 3mm (1in × 6BA) (2 off) plus nuts, washers and solder tags to suit; enamelled copper wire, 100gm (4oz) 18s.w.g. (16a.w.g.), 50gm (2oz) 36s.w.g. (32a.w.g.); acrylic sheet for spacer strip and support brackets; Superglue.

Secondary Spark Gap

Brass strips, 9mm × 2mm × 300mm (3/8in × 1/16in × 12in) (2 off); terminals (2 off)

Insulated base

Acrylic sheet, 305mm × 200mm (12in × 8in) (3 off); softwood strip, 45mm × 19mm × 1200mm (2in × 1in nominal × 48in); wood glue, c/s screws 3/4in (19mm); nails; connecting wire; polythene tubing; terminals (2 off); min. crocodile clips (2 off); self-adhesive rubber feet (4 off); clear cellulose and finishing materials.

Current drain, when the Tesla transformer is being powered, is between 1.5A and 2A.

The metal chassis and the transformer core *must* be connected to mains Earth, and the equipment protected by a fuse of no more than 3A rating (a slow-blow 1A type is to be preferred).

TESLA TRANSFORMER

Through the action of high-voltage capacitor C5 and the spark gap, the primary of the air-cored Tesla transformer, T3, is pulsed with e.h.t. supplied by the ignition coil. The operation of the Tesla transformer has already been discussed.

COMPONENTS

The primary circuit spark gap, high voltage capacitor C5, and the Tesla transformer, are home-made and their construction is described later.

Car ignition coils can be purchased from spare parts retailers. The coil used is the type fitted in Mark II and Mark III Ford Escorts (it was the cheapest stocked), but almost any ignition coil should prove satisfactory. Wrecker's yards sell salvaged coils

at typically less than half new price, but take a test meter along and check the windings. The primary resistance should be a little more than 1Ω, the secondary around 10kΩ.

Primary and secondary are connected, auto transformer fashion, but there should be no connection between the windings and the metal case. The distributor lead fitted in cars is formed from fairly high resistance carbon strands in order to suppress electrical interference, and *must not* be used for this project.

Any npn silicon transistor with voltage, current and power ratings equal to, or greater than, those of the 2N3055 should prove suitable, but base connections and mounting details will vary. Transistors of this kind, and the remaining components, are widely available, and no difficulty should be encountered with supplies.

Acrylic sheet, 2mm thick, is used as the dielectric in the high-voltage capacitor and for the base and supports of the Tesla transformer. This material is retailed by most major DIY outlets as a double glazing product. Details of a mail-order supplier are given on this month's *ShopTalk* page.

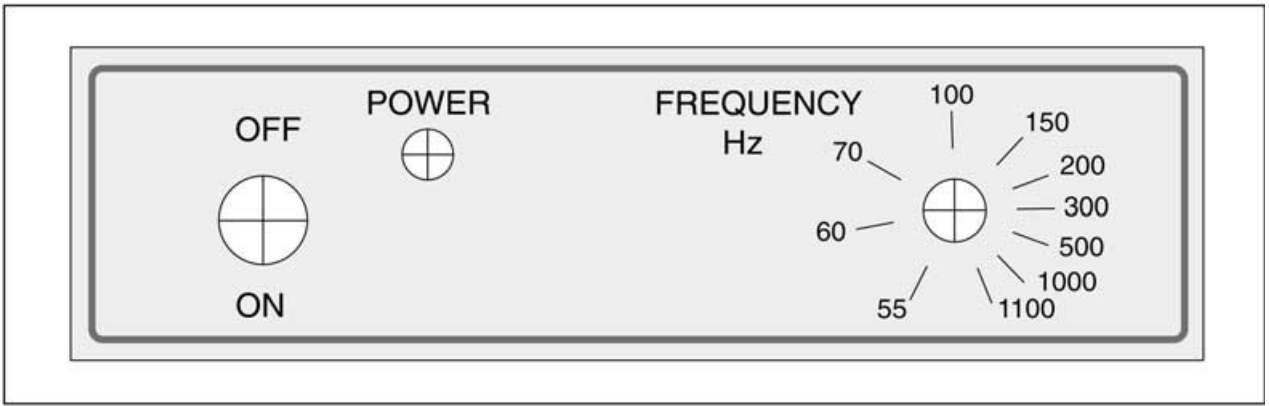

Fig.3. Full-size front panel, including panel-mounted control lettering.

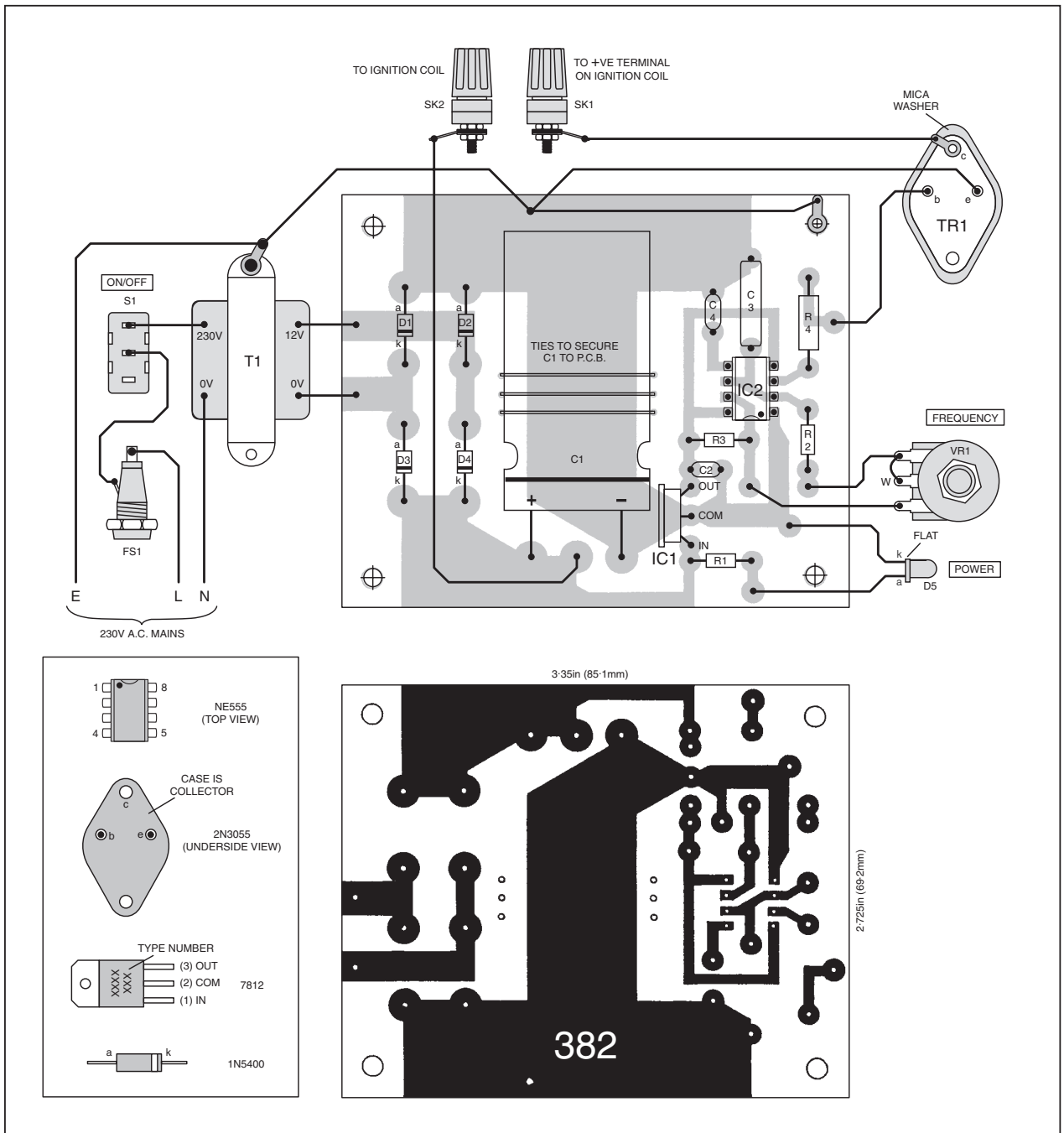
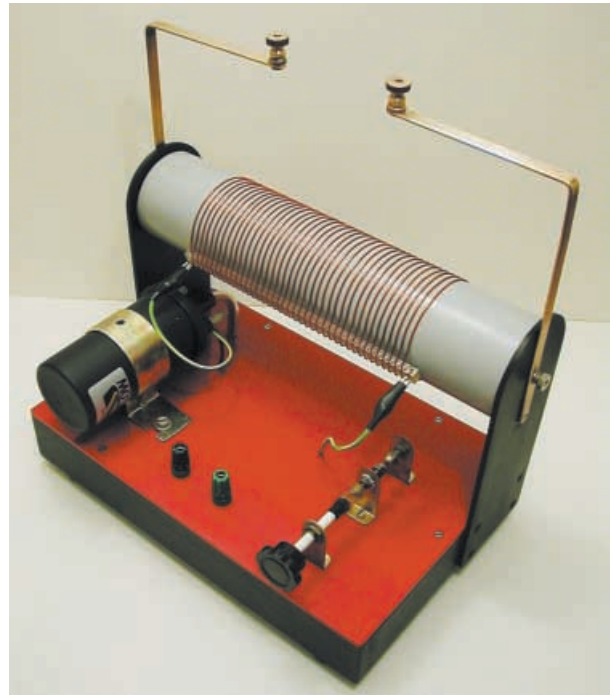

Fig.4. Power Supply and Pulser Unit printed circuit board component layout, interwiring details, semiconductor pinouts (inset) and full-size copper foil master.



The completed Power Supply and Pulsing Unit showing the "shroud" protecting the mains transformer.



Completed Tesla Transformer Unit showing the primary and secondary spark gaps and the coil tapping clips.

CONSTRUCTION

Readers who have no experience of building or commissioning mains-powered equipment are reminded that the voltages involved can KILL. They must seek the help of an experienced constructor before embarking on this project.

POWER SUPPLY AND PULSING UNIT

The power supply and pulsing unit are assembled on a metal chassis; the Tesla transformer, with its ignition coil energizer, on an insulated base. This isolates vulnerable semiconductors from the extra-high-voltage parts of the circuit.

The mains transformer and power transistor TR1 are mounted directly onto an aluminium chassis, 150mm × 100mm × 50mm (6in × 4in × 2in). The chassis acts as a heatsink for the power transistor, which must be provided with an insulating washer and secured by insulated bolts.

Any above-chassis transformer connections which carry mains voltages must be shielded by an insulating cover.

Frequency adjusting potentiometer VR1, i.e.d. on/off indicator D5, and toggle switch S1, are located on one of the chassis sides. The various photographs should make the arrangement clear. The annotated front panel is reproduced full-size in Fig.3.

Component tolerances will affect the dial calibration, but it should remain accurate enough to be useful. The original was protected against soiling by a piece of acrylic sheet.

CIRCUIT BOARD

The remaining components are mounted on the printed circuit board (p.c.b.) as shown in Fig.4, along with its track layout details.

Use an i.c. socket for IC2 to facilitate substitution checking. The socket should be soldered in first.

Then solder the remaining components in order of ascending size, and mount the semiconductors last. Reservoir capacitor C1 has to be mounted horizontally or the p.c.b. will not fit inside a 50mm deep chassis. Radial capacitors should be tied to the board using cable ties; axial types will be retained by their lead-out wires. Solder pins, inserted at the lead-out points, ease the task of off-board wiring.

Before securing the board to the chassis, using stand-off pillars, check it for bridged tracks and poor soldered joints. Check also the orientation of the semi-

conductors, the i.c.s and the electrolytic capacitor, C1.

Terminal posts are mounted through the top of the chassis for the connections to the high-voltage board.

TESLA TRANSFORMER UNIT

The construction of the high-voltage capacitor, C5, the insulating base and the Tesla Transformer, involves the cutting of 2mm thick acrylic sheet. This is best done by deeply scoring it, on both sides, with a Stanley knife or similar, and then snapping it along the score line.

Use the back of the knife rather than the sharpened edge. This will scrape a very

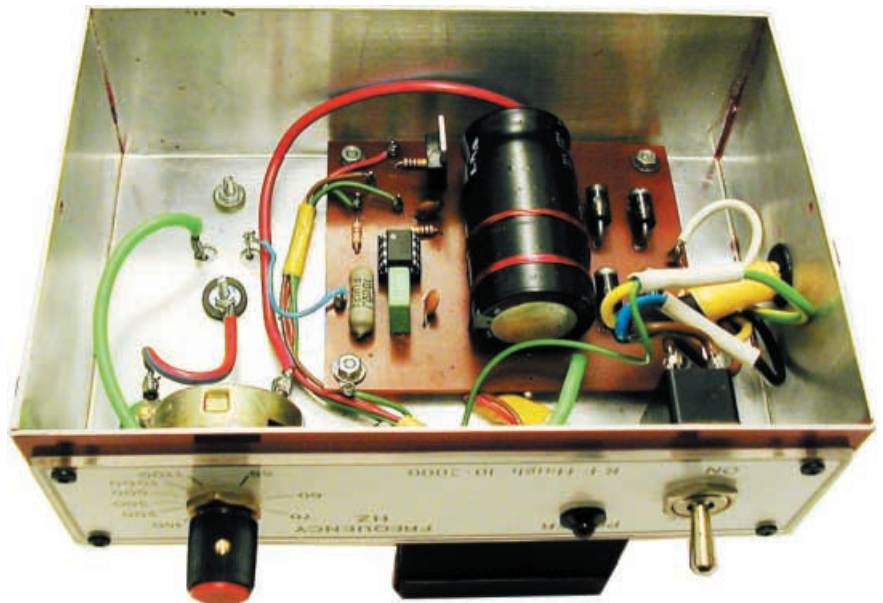

Interior component layout showing general positioning of the p.c.b. Note the power transistor must be mounted using an insulating kit.

narrow groove in the sheet and produce the cleanest cut.

HIGH VOLTAGE CAPACITOR

The construction of capacitor C5 is illustrated in Fig.5. Aluminium baking foil forms the plates and acrylic sheet acts as the dielectric.

Keep the foil the specified distances from the outer edges of the acrylic sheet or the insulation of the capacitor will be compromised. The foil should be as smooth and wrinkle free as possible; air trapped inside the capacitor can be ionized by the high voltages.

Alternate leaves of foil are brought out at opposite ends of the capacitor. Strip 70mm of insulation from the connecting wires and wrap the projecting leaves of foil around them to make the connections to the plates. On completion, tightly bind the assembly with insulating tape.

PRIMARY SPARK GAP

The construction of the primary circuit spark gap is detailed in Fig.6. Although the output from an ignition coil is not as dangerous as that from a high-voltage mains transformer, a shock from it is profoundly unpleasant. There must, therefore, be a high degree of insulation between the spark gap terminal and the control knob.

A plastic knob will not, by itself, afford adequate protection at these voltages.

The operation of the adjustable gap will be evident from the drawing. The control rotates a bolt and the cap-nut electrode on its end is driven towards a fixed electrode. The bearing for the moving electrode is a nut, soldered to the brass support bracket.

Tin (heat and flow solder over) the face of the nut, and the bracket in the region of the hole. Smear grease on a bolt and use it to secure the nut to the bracket. Apply the soldering iron until the solder flows and the nut and bracket are sweated together. A 25W iron should be adequate.

Greasing the holding bolt prevents the solder attaching to it, and it can be withdrawn when cool. If cap nuts cannot be obtained, file the ends of the bolts to dome them a little.

Use a short length of plastic sleeving to link the moving electrode bolt to the plastic control spindle. Sleeving can be

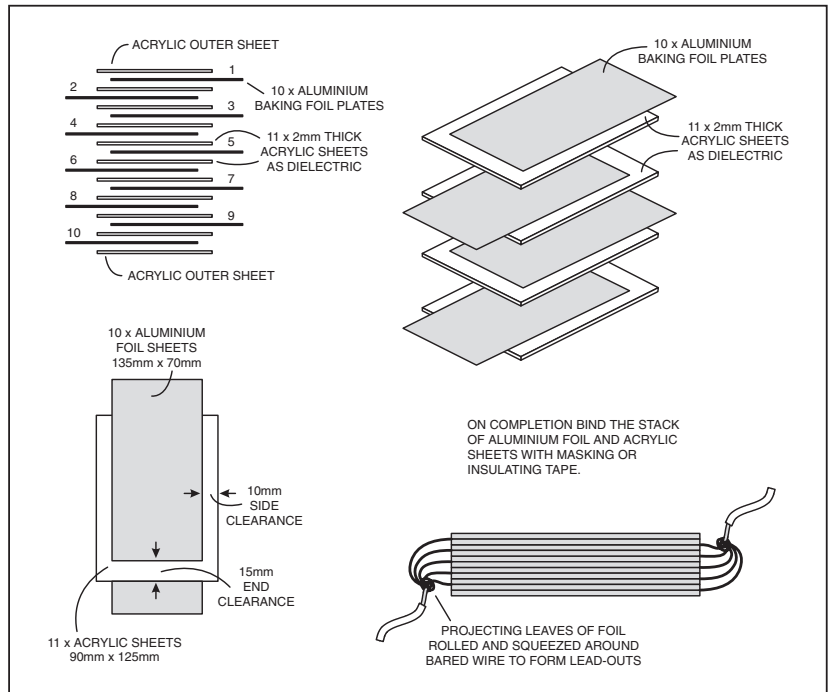

Fig.5. Making the high voltage capacitor (C5). Aluminium baking foil forms the plates and acrylic sheet acts as the dielectric.

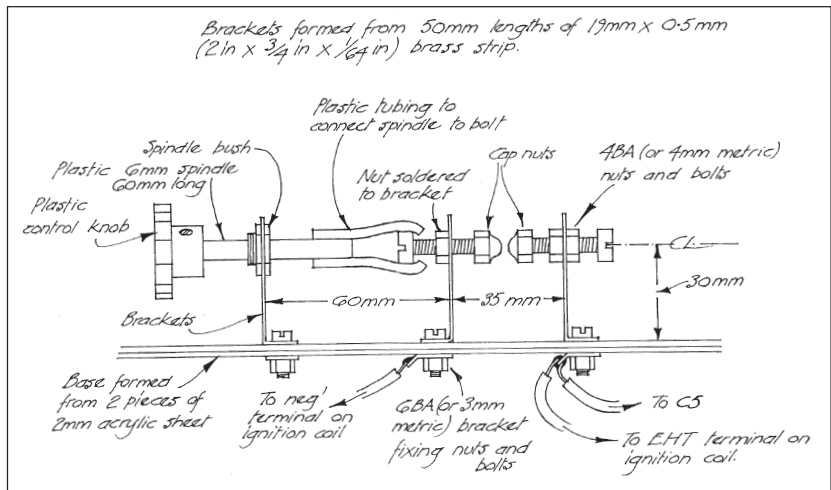
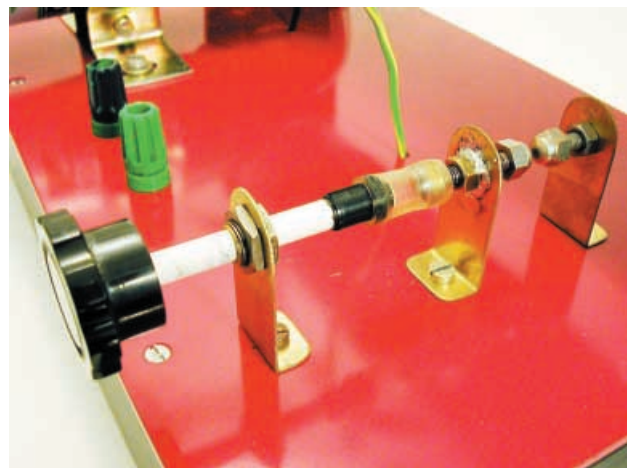

Fig.6. Suggested method of constructing the primary spark gap. There must be a high degree of insulation between the spark gap terminal and control knob.



The high voltage capacitor mounted beneath the Tesla Transformer Unit.



Close-up of the spark gap assembly. Note the insulation sleeve between knob spindle and gap screw terminal.

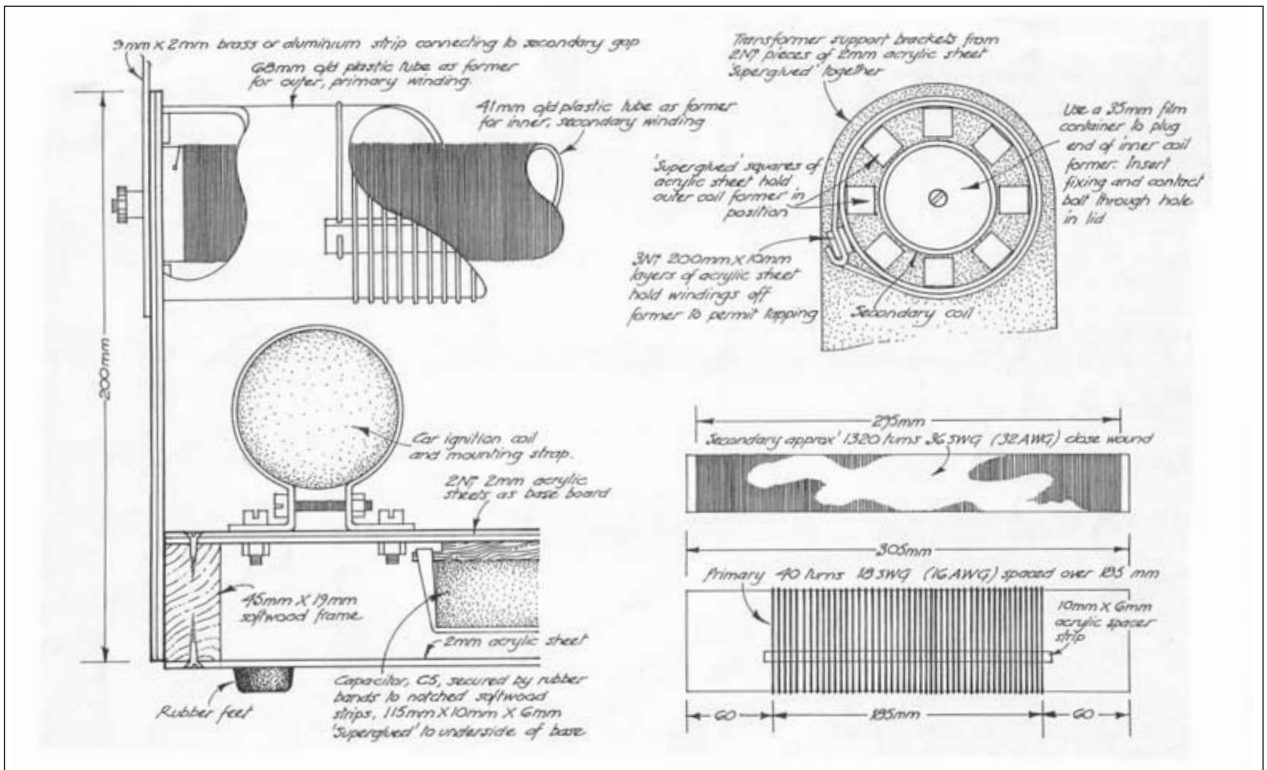

Fig. 7. Tesla Transformer and base unit assembly details.

obtained by stripping the outer insulation from a round cable of appropriate size. Alternatively, use the polythene tubing retailed by suppliers of home brewing equipment.

The plastic spindle and a bush can be salvaged from an old rotary potentiometer. Almost all model shops sell brass strip for the brackets, and most stock plastic rod or tube suitable for the spindle.

TESLA TRANSFORMER

The construction of the Tesla transformer is shown in Fig. 7. In true Tesla fashion, the primary is wound outside the secondary and spaced from it. This spacing prevents flash-over between the windings. It also reduces the damping on the resonant secondary, thereby increasing its *Q* factor.

The coils are wound on 305mm (12in) lengths of the kind of plastic pipe used for domestic plumbing. The primary is wound on 68mm outside diameter rainwater pipe (2.5in internal diameter). The secondary is wound on 41mm outside diameter waste pipe (1.5in internal diameter).

PRIMARY WINDING

The 18s.w.g. primary winding is held off the coil former by an acrylic strip to facilitate tapping with miniature crocodile clips. This strip is built up from three lengths of acrylic sheet, bonded together with Superglue (cyanoacrylate adhesive), to produce a thickness of 6mm (1/4in). The ends of the winding are held in holes, drilled through the strip at either end. Stick the strip to the former with Superglue.

Wind on 40 turns of 18s.w.g. (16a.w.g.) enamelled copper wire. Keep the winding as tight as possible, then space out the turns evenly, with the tip of a screwdriver, when the ends have been secured in the holes in

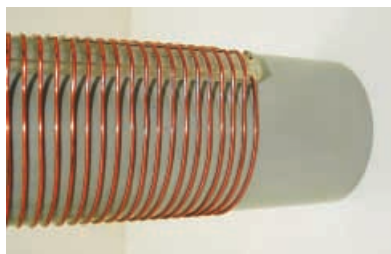

Acrylic spacer strip holds winding proud of the former to permit tapping.

the acrylic strip. Hold the turns in place with a coat of clear cellulose. When this has dried, scrape the windings, exposing bare metal along the line of the acrylic strip to ensure a good contact with the tapping clips.

SECONDARY WINDING

The secondary has to be close-wound, i.e., with turns touching, and this is more difficult. Fit a couple of brackets to a board and, using the former fixing bolts as spindles, rotate the former with one hand and feed on the 36s.w.g. (32a.w.g.) enamelled copper wire with the other, counting 1320 full turns.

Arrange some means of locking the former, and maintaining tension on the wire, so that the winding won't unravel if work is interrupted. Wedges and/or weights will do the trick. With a little care and patience, a perfect winding can be produced. Again, give the turns a coat of clear cellulose to hold them in position. Connections to the coil are via the fixing bolts.

BASE AND COIL SUPPORTS

Form the base by securing two layers of 2mm acrylic sheet to a softwood frame. The frame can be simply butt jointed, and

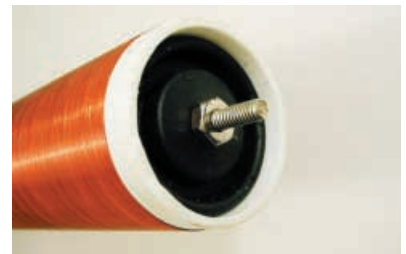

Using a film can lid and bolts to secure the secondary winding to the side supports.

glued and nailed at the corners. A single piece of acrylic sheet should be secured over the underside of the base in order to prevent accidental contact with the high-voltage circuitry.

Supports for the Tesla transformer are cut from acrylic sheet, two layers being Superglued together to increase rigidity. The supports are screw-fixed to the sides of the base, which must, of course, be exactly the same length as the coil formers.

The inner, secondary coil is secured to the supports by bolts, passed through the lids of 35mm plastic film containers pushed into the ends of the former. A few turns of masking tape around the container will ensure a tight fit inside the plastic tubing.

The outer, primary coil is spaced from the secondary by squares of acrylic sheet Superglued to the supports. Tightening the secondary winding fixing bolts holds the entire assembly in place.

SECONDARY SPARK GAP

The bolts holding the formers in their supports also secure 9mm x 2mm brass strips, carried up and over the transformer to form the secondary spark gap.

Fit terminals at the gap ends of the brass strips, which should be about 75mm (3in) apart. The terminals are used to secure lengths of wire which adjust the width and shape of the gap.

MOUNTING THE COMPONENTS

The car ignition coil is secured by bolting its fixing strap to the base. Mount the coil so that its terminals are facing inwards, towards the Tesla transformer. The primary spark gap brackets are likewise bolted to the base. Solder tags, located on the underside, enable the gap to be connected into circuit.

The high-voltage capacitor, C5, is secured by stout rubber bands to notched softwood strips Superglued to the underside of the acrylic sheets. Fig.6 and Fig.7, together with the photographs, should make the arrangement clear.

Terminals, bolted into the base, are used to connect the high-voltage board to the 12V power supply and pulser unit.

WIRING UP

Four 4mm diameter holes must be drilled through the top sheets so that leads from the ignition coil and Tesla transformer primary can be taken to the capacitor, the spark gap and the terminals. With so few components, wiring up is quite straightforward and no difficulty should be encountered.

The primary circuit wiring is carrying potentials in the region of 25kV, and lengths of thick polythene tubing were slid over the leads in the prototype to improve the insulation. Suitable tubing can be obtained from retailers of home brewing equipment.

COMMISSIONING THE UNIT

Do not connect the power supply and pulser to the high-voltage board without first reading the warnings given below. Do not insert the 555 device, IC2, into its socket until the regulator output has been checked.

Connect the power supply to the mains and check the voltage across the reservoir capacitor, C1. It should be in the region of 17V. Check the voltage at the output of the regulator, IC1. It should be 12V (within a few per cent).

If all is in order, disconnect the unit from the mains, allow the charge on C1 to dissipate, and insert IC2.

Wire a 1k Ω resistor in series with a loudspeaker (or 10k Ω in series with a pair of earphones) and connect the arrangement to the output terminals. Connect the power supply to the mains. The speaker or earphones should emit a tone. Rotate potentiometer VR1. The tone should sweep from a low to a high frequency.

This completes the initial checking of the power supply and pulser unit.

POWERING UP

Attach the crocodile clips to connect the entire Tesla transformer primary into circuit. Connect short lengths of stout, bare wire to the terminals on the secondary spark gap, reducing its width to about 25mm (1in). Using leads about 600mm (2ft) long, connect the power supply to the high-voltage board and

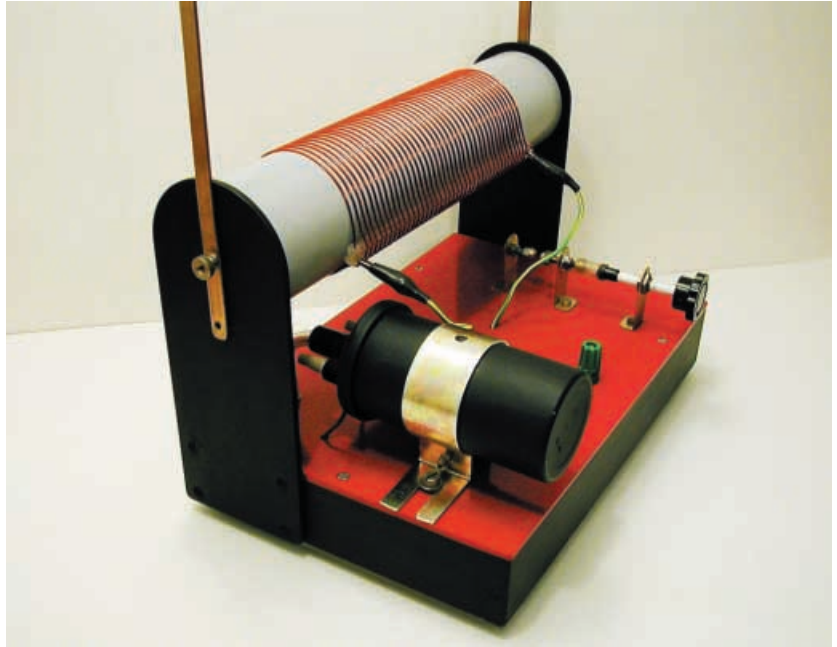

The car ignition coil bolted to the top of the Pulser base using its fixing strap. The baseboard is made from acrylic sheets and a softwood frame.



Using wooden strips and elastic bands to suspend the high voltage capacitor on the underside of the Pulser Unit.

switch on the mains. Advance the frequency control. The ignition coil should emit a faint tone of rising pitch.

With the frequency control set at about 450Hz, rotate the primary spark gap adjustment knob, driving the electrodes closer together until an arc is struck. A discharge should now take place across the secondary spark gap. Adjust the frequency of the pulser unit and the primary circuit gap until a fat, hissing discharge is occurring across the secondary spark gap.

With the prototype, the most potent results were obtained with the primary spark gap closed down as much as possible and the frequency turned up to around 500Hz.

Disconnect the unit from the mains, widen the secondary gap, then try for a longer spark. Repeat this process, and experiment with the tappings to the primary, until the longest, fattest spark is obtained.

Always remember to disconnect the unit from the mains before making any adjustments.

Careful adjustment of the prototype unit resulted in a continuous discharge 40mm (1.5in) long between 12mm (1/2in) diameter metal spheres. If the gap is set too wide to produce a discharge, blue streamers are emitted from the electrodes but the room has to be darkened to make them clearly visible. Clean the primary spark gap

electrodes, at frequent intervals, with fine emery paper.

SHOCKS FROM THE SECONDARY

If the pulsing frequency is too low and the primary spark gap set too wide, a thin, crackling discharge will be produced by the transformer secondary. The frequency of this discharge is low enough to produce sensations of electric shock. To avoid this, always adjust the frequency and gap settings for a fat, luminous, hissing spark.

DISPLAYS

A fluorescent tube held close to the unit will glow quite brightly. If one terminal of the secondary is connected to a clear glass light bulb, streamers of glowing gas will form within the bulb. Bending the gap wires into a slight "V" shape will produce a rising, flickering discharge. □



A fluorescent tube held close to the Tesla Transformer.



Glowing gas inside a filament bulb.

Radio Bygones

The leading magazine
for vintage radio
enthusiasts



WHETHER your interest is in restoring domestic radio and TV or in amateur radio, in military, aeronautical or marine communications, in radar and radio navigation, in instruments, in broadcasting, in audio and recording, or in professional radio systems fixed or mobile, RADIO BYGONES is the magazine for you.

ARTICLES on restoration and repair, history, circuit techniques, personalities, reminiscences and just plain nostalgia – you'll find them all. Plus features on museums and private collections and a full-colour photo-feature in every issue.

IT'S MOSTLY about valves, of course, but 'solid-state' – whether of the coherer and spark-gap variety or early transistors – also has a place.

FROM THE DAYS of Maxwell, Hertz, Lodge and Marconi to what was the state-of-the-art just a few short years ago . . .

There is also a selection of free readers' For Sale and Wanted advertisements in every issue.

Radio Bygones covers it all!

THE MAGAZINE is published six times a year, and is available by postal subscription. **It is not available at newsagents.**

TO TAKE OUT a subscription, or to request a sample copy, please complete the form below and return it to:

RADIO BYGONES, Wimborne Publishing Ltd, 408 Wimborne Road East, Ferndown, Dorset BH22 9ND.

Tel: 01202 873872. Fax 01202 874562. Web sites: www.radiobygones.co.uk www.radiobygones.com

RADIO BYGONES ORDER FORM

A SAMPLE COPY of Radio Bygones £3.25
(Add 70p for overseas Airmail postage)

SUBSCRIPTIONS (post paid):	1 YEAR	2 YEAR
UNITED KINGDOM	£18.50	£35.00
REST OF EUROPE (AIRMAIL)	£20.50	£39.00
REST OF THE WORLD (AIRMAIL)	£24.50	£47.00

- Yes, I would like a sample copy of RADIO BYGONES
- Yes, I would like to take out a subscription for:
- One year (6 issues) Two years (12 issues)
- I enclose a cheque/PO for £ payable to
Wimborne Publishing Ltd (Payment in £ Sterling only)
- Please debit my Visa/Mastercard/Amex/Diners/Switch

My card number is:

.....
Please print clearly, and check that you have the number correct

Card Expiry Date: Switch Issue No.

Card Security Number
(The last three digits on or below the signature strip)

My name is

My address

. Post Code/Zip

Tel. No

Signed

rb2/03

FREE *Electronics Hobbyist Compendium* book with Teach-In 2000 CD-ROM

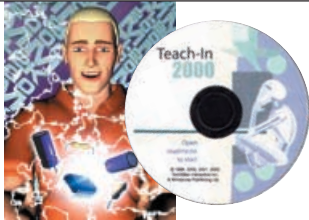

EPE TEACH-IN 2000 CD-ROM

The whole of the 12-part *Teach-In 2000* series by John Becker (published in *EPE* Nov '99 to Oct 2000) is now available on CD-ROM in PDF form. Plus the *Teach-In 2000* interactive software covering all aspects of the series and Alan Winstanley's *Basic Soldering Guide* (including illustrations and Desoldering).

Teach-In 2000 covers all the basic principles of electronics from Ohm's Law to Displays, including Op.Amps, Logic Gates etc. Each part has its own section on the interactive software where you can also change component values in the various on-screen demonstration circuits.

The series gives a hands-on approach to electronics with numerous breadboard circuits to try out, plus a simple computer interface which allows a PC to be used as a basic oscilloscope.

ONLY **£12.45** including VAT and p&p

Order code Teach-In CD-ROM

PROJECT CONSTRUCTION

PRACTICAL REMOTE CONTROL PROJECTS Owen Bishop

Provides a wealth of circuits and circuit modules for use in remote control systems of all kinds; ultrasonic, infrared, optical fibre, cable and radio. There are instructions for building fourteen novel and practical remote control projects. But this is not all, as each of these projects provides a model for building dozens of other related circuits by simply modifying parts of the design slightly to suit your own requirements. This book tells you how.

Also included are techniques for connecting a PC to a remote control system, the use of a microcontroller in remote control, as exemplified by the BASIC Stamp, and the application of ready-made type-approved 418MHz radio transmitter and receiver modules to remote control systems.

160 pages Order code BP413 £6.49

ELECTRONIC PROJECT BUILDING FOR BEGINNERS R. A. Penfold

This book is for complete beginners to electronic project building. It provides a complete introduction to the practical side of this fascinating hobby, including the following topics:

Component identification, and buying the right parts; resistor colour codes, capacitor value markings, etc; advice on buying the right tools for the job; soldering; making easy work of the hard wiring; construction methods, including stripboard, custom printed circuit boards, plain matrix boards, surface mount boards and wire-wrapping; finishing off, and adding panel labels; getting "problem" projects to work, including simple methods of fault-finding.

In fact everything you need to know in order to get started in this absorbing and creative hobby.

135 pages Order code BP392 £5.49

A PRACTICAL INTRODUCTION TO SURFACE MOUNT DEVICES Bill Mooney

This book takes you from the simplest possible starting point to a high level of competence in handworking with surface mount devices (SMD's). The wider subject of SM technology is also introduced, so giving a feeling for its depth and fascination.

Subjects such as p.c.b. design, chip control, soldering techniques and specialist tools for SM are fully explained and developed as the book progresses. Some useful constructional projects are also included.

Whilst the book is mainly intended as an introduction it is also an invaluable reference book, and the browser should find it engrossing.

120 pages Order code BP411 £5.49

FAULT-FINDING ELECTRONIC PROJECTS R. A. Penfold

Starting with mechanical faults such as dry joints, short-circuits etc, coverage includes linear circuits, using a meter to make voltage checks, signal tracing techniques and fault finding on

DIRECT BOOK SERVICE

The books listed have been selected by *Everyday Practical Electronics* editorial staff as being of special interest to everyone involved in electronics and computing. They are supplied by mail order direct to your door. Full ordering details are given on the last book page.

FOR A FURTHER SELECTION OF BOOKS
SEE THE NEXT TWO ISSUES OF EPE.

All prices include UK postage

RADIO / TV VIDEO

ELECTRONIC PROJECTS FOR VIDEO ENTHUSIASTS R. A. Penfold

This book provides a number of practical designs for video accessories that will help you get the best results from your camcorder and VCR. All the projects use inexpensive components that are readily available, and they are easy to construct. Full construction details are provided, including stripboard layouts and wiring diagrams. Where appropriate, simple setting up procedures are described in detail; no test equipment is needed.

The projects covered in this book include: Four channel audio mixer, Four channel stereo mixer, Dynamic noise limiter (DNL), Automatic audio fader, Video faders, Video wipers, Video crispener, Mains power supply unit.

109 pages Order code BP356 £5.45

SETTING UP AN AMATEUR RADIO STATION I. D. Poole

The aim of this book is to give guidance on the decisions which have to be made when setting up any amateur radio or short wave listening station. Often the experience which is needed is learned by one's mistakes, however, this can be expensive. To help overcome this, guidance is given on many aspects of setting up and running an efficient station. It then proceeds to the steps that need to be taken in gaining a full transmitting licence.

Topics covered include: The equipment that is needed; Setting up the shack; Which aerials to use; Methods of construction; Preparing for the licence.

An essential addition to the library of all those taking their first steps in amateur radio.

86 pages Order code BP300 £4.45

EXPERIMENTAL ANTENNA TOPICS H. C. Wright

Although nearly a century has passed since Marconi's first demonstration of radio communication, there is still research and experiment to be carried out in the field of antenna design and behaviour.

The aim of the experimenter will be to make a measurement or confirm a principle, and this can be done with relatively fragile, short-life apparatus. Because of this, devices described in this book make liberal use of cardboard, cooking foil, plastic bottles, cat food tins, etc. These materials are, in general, cheap to obtain and easily worked with simple tools, encouraging the trial-and-error philosophy which leads to innovation and discovery.

Although primarily a practical book with text closely supported by diagrams, some formulae which can be used by straightforward substitution and some simple graphs have also been included.

72 pages Order code BP278 £4.00

25 SIMPLE INDOOR AND WINDOW AERIALS E. M. Noll

Many people live in flats and apartments or other types of accommodation where outdoor aerials are prohibited, or a lack of garden space etc. prevents aerials from being erected. This does not mean you have to forgo shortwave-listening, for even a 20-foot length of wire stretched out along the skirting board of a room can produce acceptable results. However, with some additional effort and experimentation one may well be able to improve performance further.

This concise book tells the story, and shows the reader how to construct and use 25 indoor and window aerials that the author has proven to be sure performers. Much information is also given on shortwave bands, aerial directivity, time zones, dimensions etc.

50 pages Order code BP136 £2.25

logic circuits. The final chapter covers ways of testing a wide range of electronic components, such as resistors, capacitors, operational amplifiers, diodes, transistors, SCRs and triacs, with the aid of only a limited amount of test equipment.

The construction and use of a Tristate Continuity Tester, a Signal Tracer, a Logic Probe and a CMOS Tester are also included.

136 pages Order code BP391 £5.49

TEST EQUIPMENT CONSTRUCTION R. A. Penfold

This book describes in detail how to construct some simple and inexpensive but extremely useful, pieces of test equipment. Stripboard layouts are provided for all designs, together with wiring diagrams where appropriate, plus notes on construction and use.

The following designs are included:- AF Generator, Capacitance Meter, Test Bench Amplifier, AF Frequency Meter, Audio Multivoltmeter, Analogue Probe, High Resistance Voltmeter, CMOS Probe, Transistor Tester, TTL Probe. The designs are suitable for both newcomers and more experienced hobbyists.

104 pages Order code BP248 £4.49

ROBOTICS

INTRODUCING ROBOTICS WITH LEGO MINDSTORMS Robert Penfold

Shows the reader how to build a variety of increasingly sophisticated computer controlled robots using the brilliant Lego Mindstorms Robotic Invention System (RIS). Initially covers fundamental building techniques and mechanics needed to construct strong and efficient robots using the various "click-together" components supplied in the basic RIS kit. Explains in simple terms how the "brain" of the robot may be programmed on screen using a PC and "zapped" to the robot over an infra-red link. Also, shows how a more sophisticated Windows programming language such as Visual BASIC may be used to control the robots.

Detailed building and programming instructions provided, including numerous step-by-step photographs.

288 pages Order code BP901 £14.99

MORE ADVANCED ROBOTICS WITH LEGO MINDSTORMS - Robert Penfold

Covers the Vision Command System

Shows the reader how to extend the capabilities of the brilliant Lego Mindstorms Robotic Invention System (RIS) by using Lego's own accessories and some simple home constructed units. You will be able to build robots that can provide you with 'waiter service' when you clap your hands, perform tricks, 'see' and avoid objects by using 'bats radar', or accurately follow a line marked on the floor. Learn to use additional types of sensors including rotation, light, temperature, sound and ultrasonic and also explore the possibilities provided by using an additional (third) motor. For the less experienced, RCX code programs accompany most of the featured robots. However, the more adventurous reader is also shown how to write programs using Microsoft's VisualBASIC running with the ActiveX control (Spirit.OCX) that is provided with the RIS kit.

Detailed building instructions are provided for the featured robots, including numerous step-by-step photographs. The designs include rover vehicles, a virtual pet, a robot arm, an 'intelligent' sweet dispenser and a colour conscious robot that will try to grab objects of a specific colour.

298 pages Order code BP902 £14.99

CIRCUITS AND DESIGN

AN INTRODUCTION TO PIC MICROCONTROLLERS

Robert Penfold

Designing your own PIC based projects may seem a daunting task, but it is really not too difficult providing you have some previous experience of electronics.

The PIC processors have plenty of useful features, but they are still reasonably simple and straightforward to use. This book should contain everything you need to know.

Topics covered include: the PIC register set; numbering systems; bitwise operations and rotation; the PIC instruction set; using interrupts; using the analogue to digital converter; clock circuits; using the real time clock counter (RTCC); using subroutines; driving seven segment displays.

166 pages

Temporarily out of print

PRACTICAL OSCILLATOR CIRCUITS

A. Flind

Extensive coverage is given to circuits using capacitors and resistors to control frequency. Designs using CMOS, timer i.c.s and op.amps are all described in detail, with a special chapter on "waveform generator" i.c.s. Reliable "white" and "pink" noise generator circuits are also included.

Various circuits using inductors and capacitors are covered, with emphasis on stable low frequency generation. Some of these are amazingly simple, but are still very useful signal sources.

Crystal oscillators have their own chapter. Many of the circuits shown are readily available special i.c.s for simplicity and reliability, and offer several output frequencies. Finally, complete constructional details are given for an audio sinewave generator.

133 pages

Order code BP393

£5.49

PRACTICAL ELECTRONICS HANDBOOK –

Fifth Edition. Ian Sinclair

Contains all of the everyday information that anyone working in electronics will need.

It provides a practical and comprehensive collection of circuits, rules of thumb and design data for professional engineers, students and enthusiasts, and therefore enough background to allow the understanding and development of a range of basic circuits.

Contents: Passive components, Active discrete components, Circuits, Linear I.C.s, Energy conversion components, Digital I.C.s, Microprocessors and micro-processor systems, Transferring digital data, Digital-analogue conversions, Computer aids in electronics, Hardware components and practical work, Micro-controllers and PLCs, Digital broadcasting, Electronic security.

440 pages

Order code NE21

£16.99

COIL DESIGN AND CONSTRUCTIONAL MANUAL

B. B. Babani

A complete book for the home constructor on "how to make" RF, IF, audio and power coils, chokes and transformers. Practically every possible type is discussed and calculations necessary are given and explained in detail. Although this book is now twenty years old, with the exception of toroids and pulse transformers little has changed in coil design since it was written.

96 pages

Order code 160

£4.49

OPTOELECTRONICS CIRCUITS MANUAL

R. M. Marston

A useful single-volume guide to the optoelectronics device user, specifically aimed at the practical design engineer, technician, and the experimenter, as well as the electronics student and amateur. It deals with the subject in an easy-to-read, down-to-earth, and non-mathematical yet comprehensive manner, explaining the basic principles and characteristics of the best known devices, and presenting the reader with many practical applications and over 200 circuits. Most of the i.c.s and other devices used are inexpensive and readily available types, with universally recognised type numbers.

182 pages

Order code NE14

£20.99

OPERATIONAL AMPLIFIER USER'S HANDBOOK

R. A. Penfold

The first part of this book covers standard operational amplifier based "building blocks" (integrator, precision

rectifier, function generator, amplifiers, etc), and considers the ways in which modern devices can be used to give superior performance in each one. The second part describes a number of practical circuits that exploit modern operational amplifiers, such as high slew-rate, ultra low noise, and low input offset devices. The projects include: Low noise tape preamplifier, low noise RIAA pre-amplifier, audio power amplifiers, d.c. power controllers, opto-isolator audio link, audio millivolt meter, temperature monitor, low distortion audio signal generator, simple video fader, and many more.

120 pages

Order code BP335

£5.45

A BEGINNERS GUIDE TO CMOS DIGITAL ICs

R. A. Penfold

Getting started with logic circuits can be difficult, since many of the fundamental concepts of digital design tend to seem rather abstract, and remote from obviously useful applications. This book covers the basic theory of digital electronics and the use of CMOS integrated circuits, but does not lose sight of the fact that digital electronics has numerous "real world" applications.

The topics covered in this book include: the basic concepts of logic circuits; the functions of gates, inverters and other logic "building blocks"; CMOS logic i.c. characteristics, and their advantages in practical circuit design; oscillators and monostables (timers); flip/flops, binary dividers and binary counters; decade counters and display drivers.

119 pages

Order code BP333

£5.45

AUDIO AND MUSIC

INTRODUCTION TO DIGITAL AUDIO

(Second Edition) Ian Sinclair

The compact disc (CD) was the first device to bring digital audio methods into the home.

This development has involved methods and circuits that are totally alien to the technician or keen amateur who has previously worked with audio circuits. The principles and practices of digital audio owe little or nothing to the traditional linear circuits of the past, and are much more comprehensible to today's computer engineer than the older generation of audio engineers.

This book is intended to bridge the gap of understanding for the technician and enthusiast. The principles and methods are explained, but the mathematical background and theory is avoided, other than to state the end product.

128 pages

Order code PC102

£8.95

VALVE & TRANSISTOR AUDIO AMPLIFIERS

John Linsley Hood

This is John Linsley Hood's greatest work yet, describing the milestones that have marked the development of audio amplifiers since the earliest days to the latest

systems. Including classic amps with valves at their heart and exciting new designs using the latest components, this book is the complete world guide to audio amp design.

Contents: Active components; Valves or vacuum tubes; Solid-state devices; Passive components; Inductors and transformers; Capacitors, Resistors, Switches and electrical contacts; Voltage amplifier stages using valves; Valve audio amplifier layouts; Negative feedback; Valve operated power amplifiers; Solid state voltage amplifiers; Early solid-state audio amplifiers; Contemporary power amplifier designs; Preamplifiers; Power supplies (PSUs); Index.

250 pages

Order code NE24

£21.99

AUDIO AMPLIFIER PROJECTS

R. A. Penfold

A wide range of useful audio amplifier projects, each project features a circuit diagram, an explanation of the circuit operation and a stripboard layout diagram. All constructional details are provided along with a shopping list of components, and none of the designs requires the use of any test equipment in order to set up properly. All the projects are designed for straight-forward assembly on simple circuit boards.

Circuits include: High impedance mic preamp, Low impedance mic preamp, Crystal mic preamp, Guitar and GP preamplifier, Scratch and rumble filter, RIAA preamplifier, Tape preamplifier, Audio limiter, Bass and treble tone controls, Loudness filter, Loudness control, Simple graphic equaliser, Basic audio mixer, Small (300mW) audio power amp, 6 watt audio power amp, 20/32 watt power amp and power supply, Dynamic noise limiter.

A must for audio enthusiasts with more sense than money!

116 pages

Order code PC113

£10.95

VALVE AMPLIFIERS

Second Edition. Morgan Jones

This book allows those with a limited knowledge of the field to understand both the theory and practice of valve audio amplifier design, such that they can analyse and modify circuits, and build or restore an amplifier. Design principles and construction techniques are provided so readers can devise and build from scratch, designs that actually work.

The second edition of this popular book builds on its main strength – exploring and illustrating theory with practical applications. Numerous new sections include: output transformer problems; heater regulators; phase splitter analysis; and component technology. In addition to the numerous amplifier and preamplifier circuits, three major new designs are included: a low-noise single-ended LP stage, and a pair of high voltage amplifiers for driving electrostatic transducers directly – one for headphones, one for loudspeakers.

288 pages

Order code NE33

£29.95

LOUDSPEAKERS FOR MUSICIANS

Vivan Capel

This book contains all that a working musician needs to know about loudspeakers; the different types, how they work, the most suitable for different instruments, for cabaret work, and for vocals. It gives tips on constructing cabinets, wiring up, when and where to use wadding, and when not to, what fittings are available, finishing, how to ensure they travel well, how to connect multi-speaker arrays and much more.

Ten practical enclosure designs with plans and comments are given in the last chapter, but by the time you've read that far you should be able to design your own!

164 pages

Order code BP297

£5.49

BOOK ORDERING DETAILS

All prices include UK postage. For postage to Europe (air) and the rest of the world (surface) please add £2 per book. For the rest of the world airmail add £3 per book. CD-ROM prices include VAT and/or postage to anywhere in the world. Send a PO, cheque, international money order (£ sterling only) made payable to **Direct Book Service** or card details, Visa, Mastercard, Amex, Diners Club or Switch to: **DIRECT BOOK SERVICE, WIMBORNE PUBLISHING LIMITED, 408 WIMBORNE ROAD EAST, FERNDOWN, DORSET BH22 9ND.**

Books are normally sent within seven days of receipt of order, but please allow 28 days for delivery – more for overseas orders. *Please check price and availability (see latest issue of Everyday Practical Electronics) before ordering from old lists.*

For a further selection of books see the next two issues of *EPE*.

Tel 01202 873872 Fax 01202 874562. E-mail: dbs@epemag.wimborne.co.uk

Order from our online shop at: www.epemag.wimborne.co.uk/shopdoor.htm

BOOK ORDER FORM

Full name:

Address:

.....

..... Post code: Telephone No:

Signature:

I enclose cheque/PO payable to DIRECT BOOK SERVICE for £

Please charge my card £ Card expiry date.....

Card Number Switch Issue No.....

Card Security Code (the last three digits on or just below the signature strip)

Please send book order codes:

.....

Please continue on separate sheet of paper if necessary

PCB SERVICE

Printed circuit boards for most recent *EPE* constructional projects are available from the PCB Service, see list. These are fabricated in glass fibre, and are fully drilled and roller tinned. All prices include VAT and postage and packing. Add £1 per board for airmail outside of Europe. Remittances should be sent to **The PCB Service, Everyday Practical Electronics, Wimborne Publishing Ltd., 408 Wimborne Road East, Ferndown, Dorset BH22 9ND. Tel: 01202 873872; Fax 01202 874562; E-mail: orders@epemag.wimborne.co.uk. On-line Shop: www.epemag.wimborne.co.uk/shopdoor.htm.** Cheques should be crossed and made payable to *Everyday Practical Electronics* (Payment in £ sterling only).

NOTE: While 95% of our boards are held in stock and are dispatched within seven days of receipt of order, please allow a maximum of 28 days for delivery – overseas readers allow extra if ordered by surface mail. Back numbers or photostats of articles are available if required – see the *Back Issues* page for details. We do not supply kits or components for our projects.

Please check price and availability in the latest issue.

A number of older boards are listed on our website.

Boards can only be supplied on a payment with order basis.

PROJECT TITLE	Order Code	Cost
Ice Alarm	FEB '01 287	£4.60
★ Graphics L.C.D. Display with PICs (Supp)	288	£5.23
Using the LM3914-6 L.E.D. Bargraph Drivers		
Multi-purpose Main p.c.b.	289	} Set £7.14
Relay Control	290	
L.E.D. Display	291	
★ PC Audio Power Meter	Software only	–
Doorbell Extender: Transmitter	MAR '01 292	£4.20
Receiver	293	£4.60
Trans/Remote	294	£4.28
Rec./Relay	295	£4.92
EPE Snug-bug Heat Control for Pets	APR '01 296	£6.50
Intruder Alarm Control Panel		
Main Board	297	£6.97
External Bell Unit	298	£4.76
Camcorder Mixer	MAY '01 299	£6.34
★ PIC Graphics L.C.D. Scope	300	£5.07
Hosepipe Controller	JUNE '01 301	£5.14
Magfield Monitor (Sensor Board)	302	£4.91
Dummy PIR Detector	303	£4.36
★ PIC16F87x Extended Memory	Software only	–
Stereo/Surround Sound Amplifier	JULY '01 304	£4.75
Perpetual Projects Uniboard-1	305	£3.00
Solar-Powered Power Supply & Voltage Reg.		
MSF Signal Repeater and Indicator		
Repeater Board	306	£4.75
Meter Board	307	£4.44
★ PIC to Printer Interface	308	£5.39
Lead/Acid Battery Charger	AUG '01 309	£4.99
Shortwave Loop Aerial	310	£5.07
★ Digitimer – Main Board	311	£6.50
– R.F. Board	312	£4.36
Perpetual Projects Uniboard-2		
L.E.D. Flasher – Double Door-Buzzer	305	£3.00
Perpetual Projects Uniboard-3	SEPT '01 305	£3.00
Loop Burglar Alarm, Touch-Switch Door-Light		
and Solar-Powered Rain Alarm		
L.E.D. Super Torches – Red Main	313	} Set £6.10
– Display Red	314	
– White L.E.D.	315	
★ Sync Clock Driver	316	£5.94
★ Water Monitor	317	£4.91
Camcorder Power Supply	OCT '01 318	£5.94
PIC Toolkit Mk3	319	£8.24
Perpetual Projects Uniboard-4. Gate Sentinel, Solar-	305	£3.00
powered Bird Scarer and Solar-Powered Register		
Teach-In 2002 Power Supply	NOV '01 320	£4.28
Lights Needed Alert	321	£5.39
Pitch Switch	322	£5.87
Capacitance Meter – Main Board (double-sided)	323	} Set £12.00
– Display Board (double-sided)	324	
★ ★ PIC Toolkit TK3 – Software only	–	
4-Channel Twinkling Lights	DEC '01 325	£6.82
Ghost Buster – Mic	326	} Set £5.78
– Main	327	
★ PIC Polywhatsit – Digital	328	
– Analogue	329	£7.61
Forever Flasher	JAN '02 330	£4.44
Time Delay Touch Switch	331	£4.60
★ PIC Magick Musick	332	£5.87
Versatile Bench Power Supply	333	£5.71
★ PIC Spectrum Analyser	FEB '02 334	£7.13
Versatile Current Monitor	335	£4.75
Guitar Practice Amp	336	£5.39
★ PIC Virus Zapper	MAR '02 337	£4.75
RH Meter	338	£4.28
★ PIC Mini-Enigma – Software only	–	–
★ Programming PIC Interrupts – Software only	–	–
★ PIC Controlled Intruder Alarm	APR '02 339	£6.50
★ PIC Big Digit Display	MAY '02 341	£6.02
Washing Ready Indicator	342	£4.75
Audio Circuits-1 – LM386N-1	343	£4.28
– TDA7052	344	£4.12
– TBA820M	345	£4.44
– LM380N	346	£4.44
– TDA2003	347	£4.60
– Twin TDA2003	348	£4.75

PROJECT TITLE	Order Code	Cost
World Lamp	JUNE '02 340	£5.71
Simple Audio Circuits-2 – Low, Med and High		
Input Impedance Preamplifiers (Single Trans.)	349	£4.60
Low-Noise Preamplifier (Dual Trans.)	350	£4.75
Tone Control	351	£4.60
Bandpass Filter	352	£4.75
Frequency Standard Generator – Receiver	353	£4.12
– Digital	354	£6.82
– Digital	355	£5.71
★ Biopic Heartbeat Monitor		
Simple Audio Circuits – 3	JULY '02	
– Dual Output Power Supply	356	£4.60
– Crossover/Audio Filter	357	£4.44
Infra-Red Autoswitch	358	£4.91
★ EPE StyloPIC	359	£6.50
Rotary Combination Lock – Main Board	360	£5.39
– Interface Board	361	£4.91
★ Using the PIC's PCLATH Command – Software only	–	–
Big-Ears Buggy	AUG '02 362	£5.71
★ PIC World Clock	363	£5.39
Simple Audio Circuits-4		
Low Freq. Oscillator	364	£4.44
Resonance Detector	365	£4.28
Vinyl-To-CD Preamplifier	SEPT '02 366	£5.71
★ Freebird Glider Control	367	£4.91
★ Morse Code Reader	368	£5.23
Headset Communicator	OCT '02 369	£4.75
EPE Bounty Treasure Hunter	370	£4.77
★ ★ Digital I.C. Tester	371	£7.14
★ PIC-Pocket Battleships – Software only	–	–
Transient Tracker	NOV '02 372	£4.75
★ PICAXE Projects-1: Egg Timer; Dice Machine;		
Quiz Game Monitor (Multiboard)	373	£3.00
★ Tuning Fork & Metronome	374	£5.39
★ ★ EPE Hybrid Computer – Main Board	} double-sided	£18.87
– Atom Board		
– Atom Board	376	£11.57
★ PICAXE Projects-2: Temperature Sensor;		
Voltage Sensor; VU Indicator (Multiboard)	373	£3.00
★ Versatile PIC Flasher	377	£5.07
★ PICAXE Projects-3: Chaser Lights	JAN '03 373	£3.00
6-Channel Mains Interface	381	£5.08
EPE Minder – Transmitter	378	£4.75
– Receiver	379	£5.39
★ Wind Speed Monitor	380	£5.08
Tesla Transformer	FEB '03 382	£5.07
★ Brainbot Buggy	383	£3.00
★ Wind Tunnel	384	£6.02

EPE SOFTWARE

Software programs for *EPE* projects marked with a single asterisk ★ are available on 3.5 inch PC-compatible disks or free from our Internet site. The following disks are available: **PIC Tutorial** (Mar-May '98); **PIC Toolkit Mk2 V2-4d** (May-Jun '99); **EPE Disk 1** (Apr '95-Dec '98); **EPE Disk 2** (1999); **EPE Disk 3** (2000); **EPE Disk 4** (2001); **EPE Disk 5** (2002); **EPE Disk 6** (Jan 2003 issue to current cover date); **EPE Teach-In 2000**; **EPE Spectrum**; **EPE Interface Disk 1** (October '00 issue to current cover date). ★ ★ The software for these projects is on CD-ROM. The 3.5 inch disks are £3.00 each (UK), the CD-ROMs are £6.95 (UK). Add 50p each for overseas surface mail, and £1 each for airmail. All are available from the *EPE PCB Service*. All files can be downloaded free from our Internet FTP site: <ftp://ftp.epemag.wimborne.co.uk>.

EPE PRINTED CIRCUIT BOARD SERVICE

Order Code Project Quantity Price

Name

Address

Tel. No.

I enclose payment of £..... (cheque/PO in £ sterling only) to:



Everyday
Practical Electronics



MasterCard, Amex, Diners
Club, Visa or Switch



Card No.

Card Exp. Date Switch Issue No

Card Security Code

(The last 3 digits on or just under the signature strip)

Signature

NOTE: You can also order p.c.b.s by phone, Fax, Email or via our Internet site on a secure server:

<http://www.epemag.wimborne.co.uk/shopdoor.htm>

**WHETHER ELECTRONICS IS YOUR HOBBY
OR YOUR LIVELIHOOD . . .**

**YOU NEED THE MODERN ELECTRONICS MANUAL
and the ELECTRONICS SERVICE MANUAL**

THE MODERN ELECTRONICS MANUAL (CD-ROM VERSION ONLY)



**NEW
CD-ROM VERSION
OF THE
MODERN ELECTRONICS
MANUAL
AVAILABLE NOW
ONLY
£29.95**

**The essential reference
work for everyone
studying electronics**

- Over 800 pages
- In-depth theory
- Projects to build
- Detailed assembly instructions
- Full components checklists
- Extensive data tables
- Manufacturers' web links
- Easy-to-use Adobe Acrobat format
- Clear and simple layout
- Comprehensive subject range
- Professionally written
- Regular Supplements

EVERYTHING YOU NEED TO GET STARTED AND GO FURTHER IN ELECTRONICS!

The revised CD-ROM edition of the Modern Electronics Base Manual (MEM) contains practical, easy-to-follow information on the following subjects:

BASIC PRINCIPLES: Electronic Components and their Characteristics (16 sections from Resistors and Potentiometers to Crystals, Crystal Modules and Resonators); Circuits Using Passive Components (10 sections); Power Supplies; The Amateur Electronics Workshop; The Uses of Semiconductors; Digital Electronics (6 sections); Operational Amplifiers; Introduction to Physics, including practical experiments; Semiconductors (5 sections) and Digital Instruments (3 sections).

CIRCUITS TO BUILD: There's nothing to beat the satisfaction of creating your own projects. From basic principles, like soldering and making printed circuit boards, to the tools needed for circuit-building, the Modern Electronics Manual and its Supplements describe clearly, with appropriate diagrams, how to assemble a radio, loudspeaker circuits, amplifiers, car projects,

a computer interface, measuring instruments, workshop equipment, security systems, medical and musical circuits, etc. The Base Manual describes 12 projects including a Theremin and a Simple TENS Unit.

ESSENTIAL DATA: Extensive tables on diodes, transistors, thyristors and triacs, digital and linear i.c.s.

EXTENSIVE GLOSSARY: Should you come across a technical word, phrase or abbreviation you're not familiar with, simply look up the glossary included in the Manual and you'll find a comprehensive definition in plain English.

The Manual also covers **Safety** and provides web links to component and equipment **Manufacturers and Suppliers**. The most comprehensive reference work ever produced at a price you can afford, the CD-ROM edition of **THE MODERN ELECTRONICS MANUAL** provides you with all the **essential** information you need.

THE MODERN ELECTRONICS MANUAL (MEM – CD-ROM version only)

Revised CD-ROM Edition of Basic Work: Contains over 800 pages of information in Adobe Acrobat format. Edited by John Becker.

Regular Supplements: Additional CD-ROMs each containing approximately 500 pages of additional information on specific areas of electronics will be available for £19.95 each. Information on the availability and content of each Supplement CD-ROM will be sent to you as they become available.

Presentation: CD-ROM suitable for any modern PC. Requires Adobe Acrobat Reader which is included on the MEM CD-ROM.

Price of the Basic Work: £29.95 POST FREE.

ORDER BOTH MANUALS TOGETHER AND SAVE £10

A mass of well-organised and clearly explained information is brought to you by expert editorial teams whose combined experience ensures the widest coverage. Regular Supplements to these unique publications, keep you abreast of the latest technology and techniques if required