

Tennis Ball Launching Crossbow

Construction Instructions

Aug 30, 1997 Matuesz z Plocka (mka [Matt Henson](#))

Modified Sept 7, 1997



Top view #1



Top view #2



Side View #1

Material List

Amounts per Crossbow	Trigger assembly not included		
qty	Item	Cost ea.	extended
1	Leather pouch (7 1/2)	\$1.00	\$1.00
4	Grommets #0	\$0.25	\$1.00
36	1/4" Rubber tubing in inches	\$0.04	\$1.44
4	50 lb tie-wraps	\$0.13	\$0.52
1	3/4" Steel Welded Ring	\$0.35	\$0.35
1	3/4" Quick Link	\$0.95	\$0.95
2	leather Strip 24-28" long, (1 1/4") Wide	\$1.00	\$1.00
2	Lag Bolts	\$0.64	\$1.28
1	stock 32" (2x4 Wood)	\$0.78	\$0.78
1	Prod 25" (2x2 Wood)	\$0.49	\$0.49
1	rod 1 5/8th long 19/64th	\$0.16	\$0.16
2	Triangle supports 2/4 (3.5)x(3.5)x(4 7/8th)	\$0.10	\$0.10
3	Wood Screw #8 (2 1/2) for Prod	\$0.16	\$0.48
4	wood Screw #8 (1 1/2) For Supports	\$0.10	\$0.40
		Total	\$10.60

Other Materials and tools not priced out.

- White Glue (for wood to wood joints)
- Barge Cement (for leather to leather and wood to leather)
- Pencil
- Tape Measure
- Leather Punch
- Knife
- Small amount of Bee's Wax
- Phillips screwdriver
- Corner clamp (*optional*)
- Hammer
- Chainsaw file
- Pliers
- Hacksaw
- Hand Saw (I use a hand held jig saw or a draw knife)
- Sandpaper (I use 80, 120, 220, and 400 grits for finishing) (*optional*)
- A Finish (I have used stains, Tru-Oil, and Wood Sealers) (*optional*)
- Drill and Drill bits
 - ○ 19/64th"
 - ○ 7/32"
 - ○ 11/32"
 - ○ 1/8"

Stock

Cut a 2x4 to a length of 32 inches. You can adjust the overall length to your preference and size but this gives you a starting point. I used Hemlock as it was cheap in my area You could use any wood for the stock. If your choice is a Hard Wood be aware that it will weigh more. If you use softer wood like cedar the joints and the center rod may loosen.

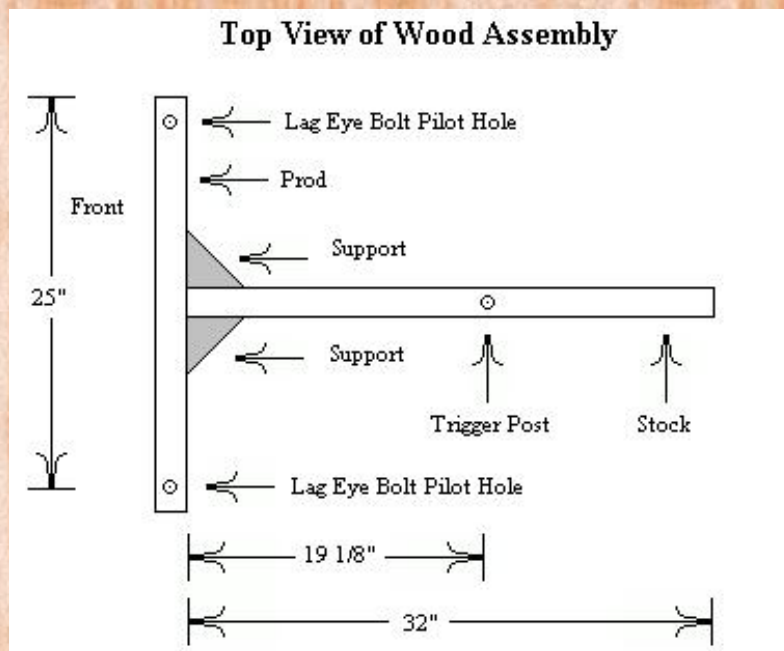

Cut shape of stock 10" to 12" from the front end tapering to 1 9/16th" at the front end. But no smaller than the width of the Prod that you are using. Mark the centerline of the stock along the top of the stock.

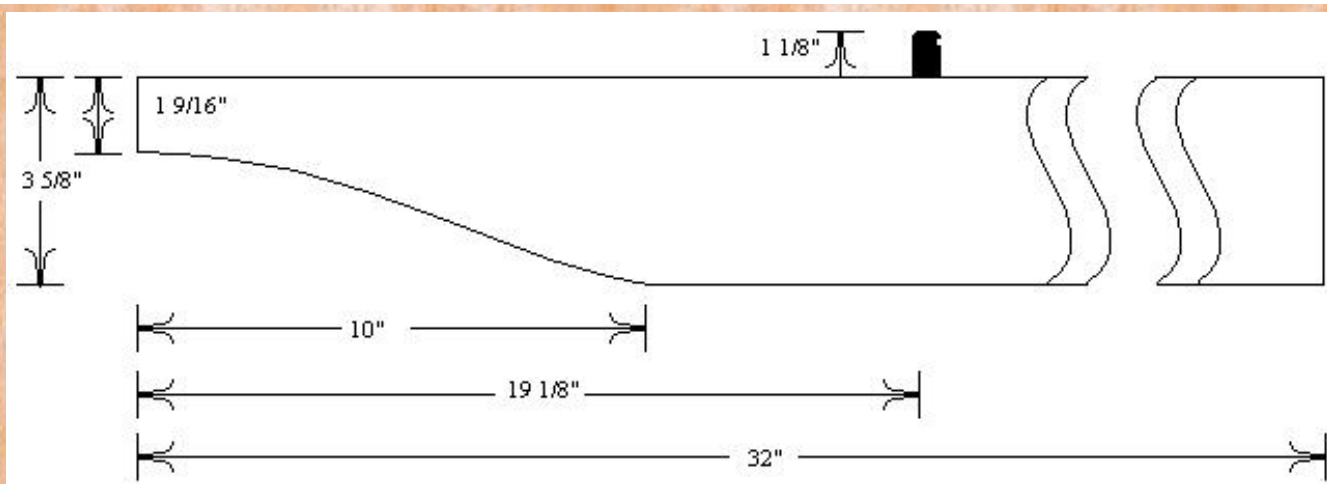

Drill a $\frac{19}{64}$ " hole $\frac{3}{4}$ " deep on top of the stock $19\frac{1}{8}$ " from the front and centered.

For the Trigger Post cut from rod ($\frac{19}{64}$ " a length of $1\frac{5}{8}$ " long then with a drop of glue drive into the stock. There should be $1\frac{1}{8}$ " should be exposed.

Notch with a chainsaw file $\frac{1}{16}$ " from the top about $\frac{1}{64}$ " deep on the back side of the Trigger Post.

Prod

Cut a prod 25" long from a 2x2. I use both VG Fir and Oak with good success. I did one with Cedar and found that the lag bolts loosen and pull out of the wood. This could be very DANGEROUS!

Drill $\frac{7}{32}$ " pilot hole $1\frac{1}{8}$ " deep along the centerline $1\frac{1}{2}$ " from each end on the top of one side. and mark it as TOP. Mark the center of the Prod for later alignment to the stock.

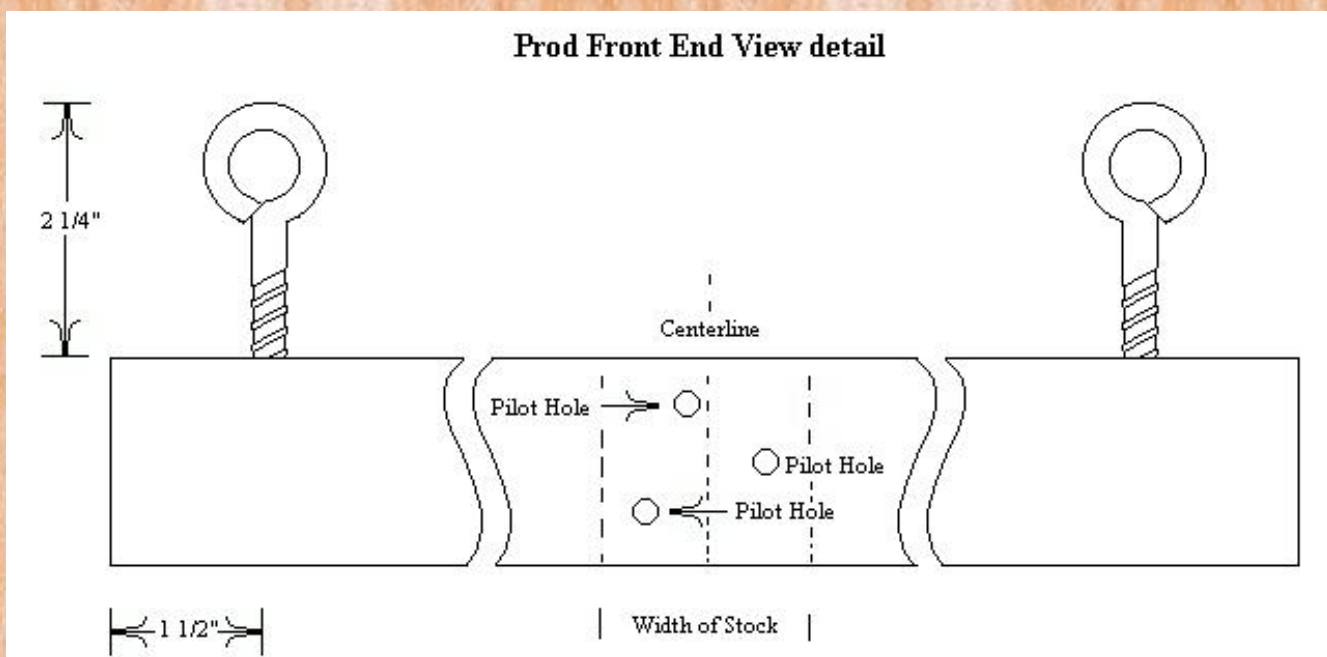

Turn the prod 90 degrees. Mark this side as Front and pre drill 3 pilot holes completely through with a $\frac{1}{8}$ " bit in the center of the prod. I normally use a corner clamp to place the prod against the stock so that when I drill the pilot holes they are also in the stock at the correct positions.

Counter sink with a $\frac{11}{32}$ " bit. This is for #8 wood screws $2\frac{1}{2}$ inches long to mount to stock.

Prod supports

Cut 2x4 into 2 triangle pieces approximately $3\frac{1}{2}$ x $3\frac{1}{2}$ x $4\frac{7}{8}$.

Drill a $\frac{1}{8}$ " pilot hole in Hypotenuse face about 1" from each edge along centerline. And counter sink with $\frac{11}{32}$ " bit.

Leather work

Cut ball pouch as shown

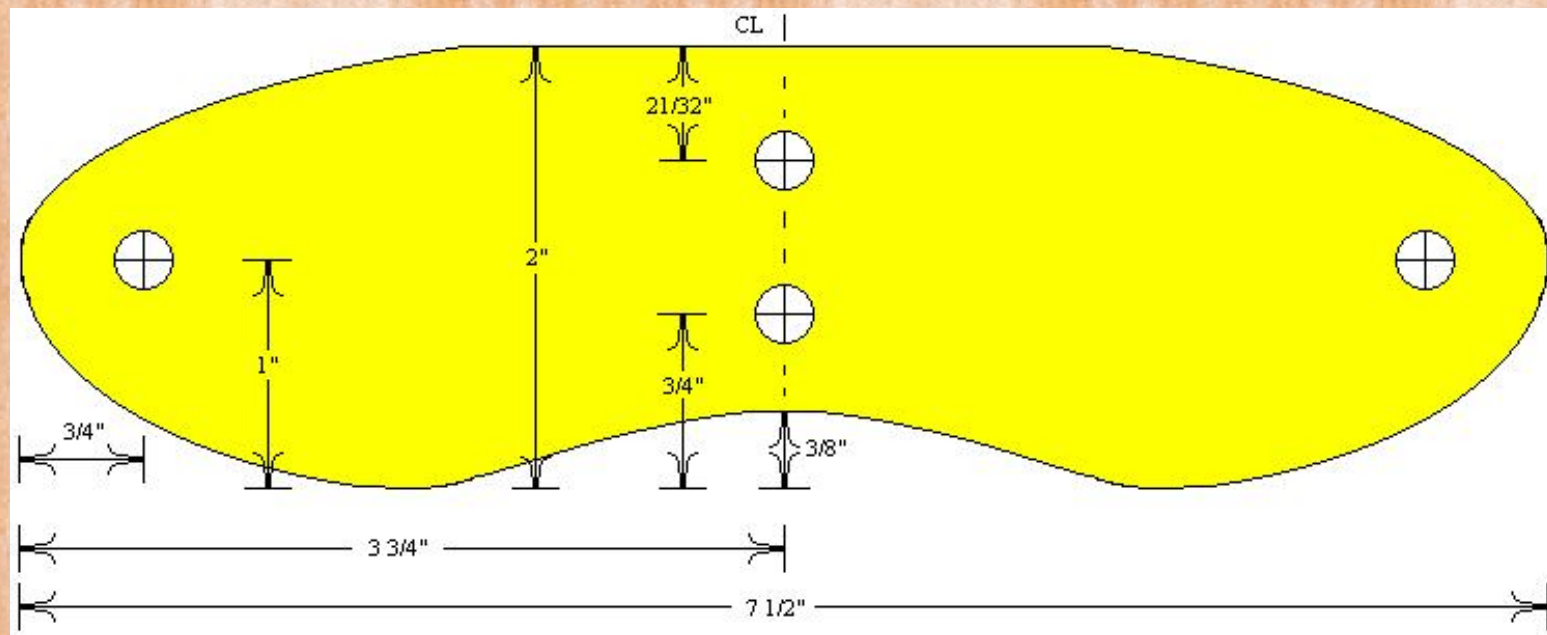

I used suede and found that I needed two layers to prevent tear-out after repeated use. I have also use old Eye Glasses cases. Lay out and cut 2 pieces of leather then glue the layers with Barge Cement or other leather glue.

Punch holes and set the #0 grommets in the pouch. I have used #1 size for the tubing ends but they are too big for the center holes.

Cut leather strip 24 to 28 inches long 1 1/4 inch wide. Punch a hole (19/64th) about 4 1/4 from one end in the center of the strip. This strip will go on the top of the stock

Assembly

Mount Prod with white glue and screw the Prod to the Stock. Glue and screw the angled supports to the Prod and Stock. To install the Lag Eye Bolts use wax on the threads, then insert till about 2 1/4" is left exposed.

Glue Leather Strip with Barge Cement. Place the strip so that the punched hole is over the trigger post and the other end wraps around the Prod to the bottom. Trim the strip to the joint of the Prod and Stock at the bottom. This strip provides two functions. To protect the edge of the prod from the Steel ring and Quick link as it rebounds after it is shot. The other function is to provide a path for the tennis ball.

Take a length of tubing (18") and thread it through the end hole of the Ball Pouch to the center of the tubing. Thread both ends of the tubing through the Eye of the bolt so that about three inches overlap. Secure with a tie wrap about one inch for the eye and another one inch from the ends. Tighten the tie wraps with the pliers. Repeat with the other end of the Ball Pouch.

Use the Quick Link to join the Steel ring and the Ball Pouch.

Draw the Steel Ring to the trigger post and allow it to rest in the notch (cocked position). Re-tighten the tie wraps and snip the excess tie wrap.

Store the Crossbow in the un-cocked position.

Firing and Use.

I find it easiest to hold the crossbow with one hand, brace the back end against my hip, and draw to the cocked position with a tennis ball in the other hand. Fire the crossbow with a "Plucking" action of the thumb and forefinger. Hold the crossbow securely as it will recoil.

Trigger Assembly (optional)

Some people like the variation of the trigger add-on.



Trigger detail #1



Trigger detail #2



Trigger in forward position



Trigger in fired position

I do plan on improving the photo's in the near future. I am sorry they are hard to see clearly, but I wanted to get this on-line as soon as I could.

Material List

Trigger add-on for Crossbow			
Qty	Item	Cost ea.	Extended
2	mending plates 2x1/2	\$0.53	\$1.06
2	upper nut 10x24	\$0.17	\$0.34
2	upper bolt 10x24x1/2	\$0.22	\$0.44
1	coarse hex cap grade 5 bolt 2 1/2x 1/4	\$0.14	\$0.14
3	nylon washers 1/4	\$0.10	\$0.30
3	USS flat Washer 1/4	\$0.03	\$0.09
1	USS flat Washer 5/16	\$0.04	\$0.04
1	nylon lock nut 1/4x20	\$0.15	\$0.15
1	corner iron 4 x 7/8	\$1.29	\$1.29
1	wood dowel handle 4 x 3/4	\$0.40	\$0.40
1	wood screw 1 3/4	\$0.16	\$0.16
2	Wood Screw 3/4	\$0.10	\$0.20
		Total	\$4.61

Assembly

Cut angle iron 1 3/4" from the right angle corner (Measure from the inside of the angle). An angle iron is what they are called in the hardware store. used mostly as shelving brackets.

Drill 13/64 holes in the iron 5/8" from the outside of the corner and drill the other hole so that the distance between the two plates is slightly larger than the post.

Assemble the mending plates (That's what they are called in the hardware store. They are small strips of metal that Have two holes drilled in them.) to the bottom of the iron with the nuts on the bottom

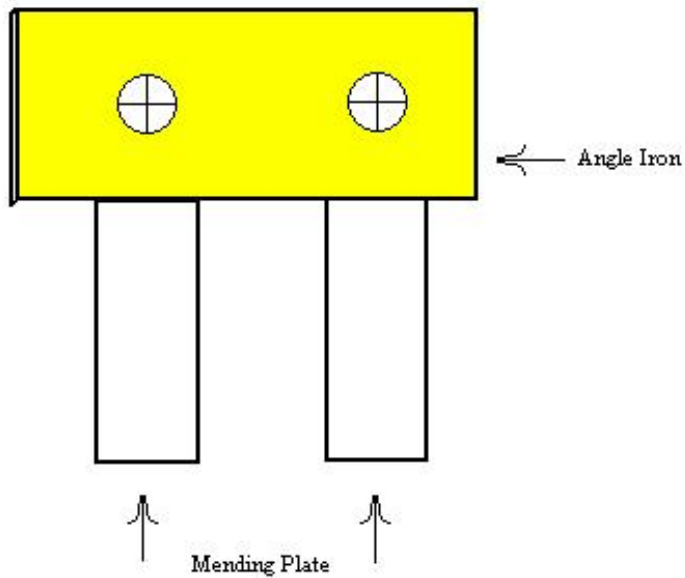

To assemble the handle drill pilot hole in the center end with a 3/32" bit and use a 2" wood screw with glue to attach the handle to the iron.

Drill a 1/4" hole in the stock 1 1/4" back from the post and 2 5/8" from the top of the stock.

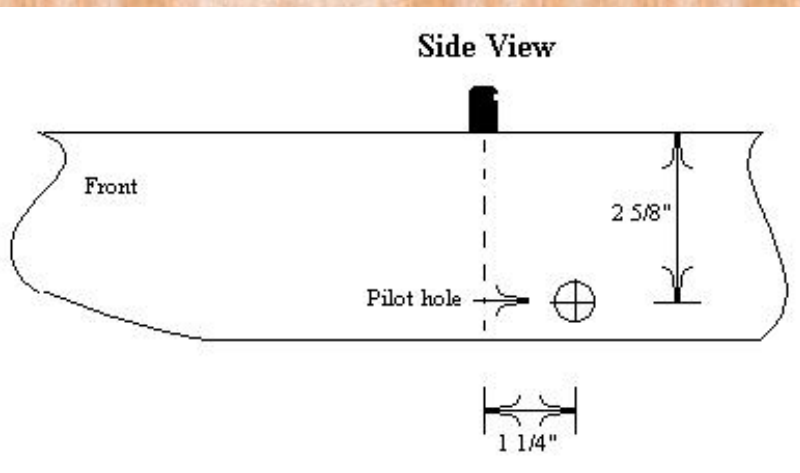

Assemble handle to the stock as shown.

Order Washer stack up on Bolt

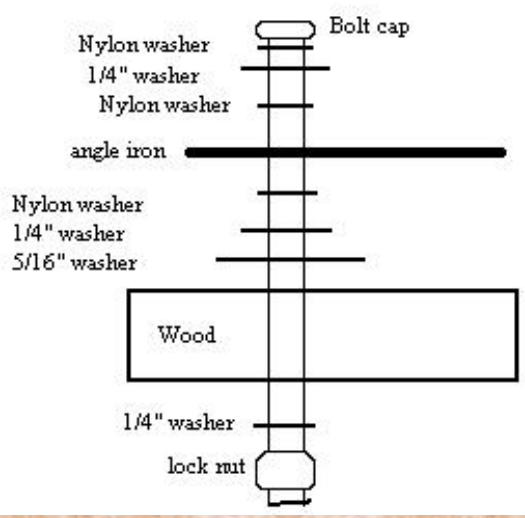

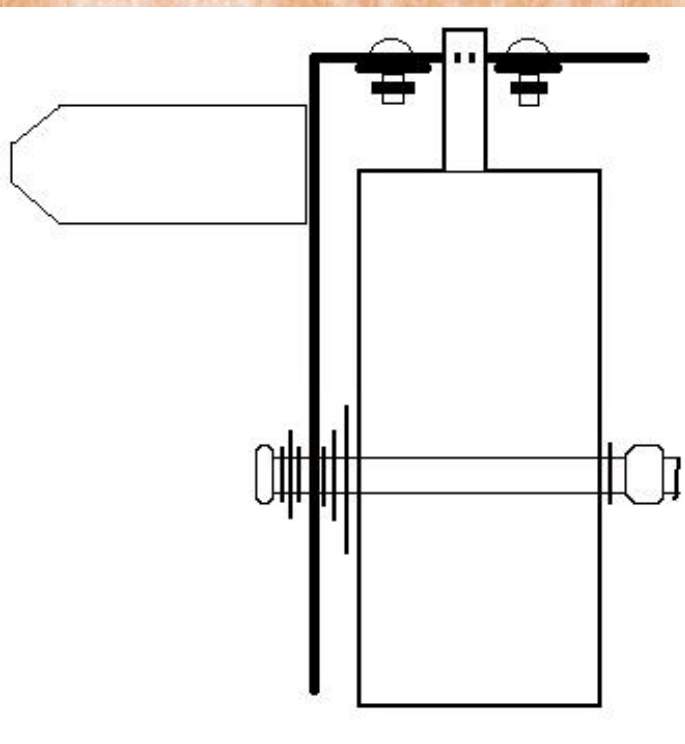

Front view

Place the handle in the forward position (rest) and install a 3/4" screw as a stop.

Place the handle in the back position (fired) so that the ends of the mending plates are about 1/4" from the post and install a 3/4" screw as a stop. This will prevent the nuts from gouging the stock when fired.

Happy Hunting!

If you find a link that is not working or just to give me feedback, I can be reached at

mhenson@telebyte.com

Thanks for stopping by.

Disclaimer: This WebPages is maintained courtesy of Matt Henson. It is not a publication of the SCA, Inc. nor does it delineate SCA policies. Neither the SCA, Inc. nor Matt Henson assumes any liability for the accuracy of information contained on this page nor the suitability of any materials linked to this page.

[Master Index Page](#) | [About Matt](#) | [Spirit Makers Guild](#) | [SCA Missile Combatants](#) | [Hobbies](#) | [Web Crawler](#) | [Yahoo](#) |

Henson Consulting

Last Modified: Monday, June 19, 2000

Matt Henson, CNE, MCP, Provides consulting in MS-DOS, Windows 3.x, Windows 95, Win98 & WinNT, Novell 1.5- 5 and a full range of business software in the Kitsap County area. Go [here](#) for more about [Matt](#) a Certified NetWare Engineer (CNE) since 1993

[Laura](#) Henson provides Desktop Publishing, Newsletters, and Web Designs. Laura also provides beginner training on MS Windows, Word, and Excel.

Thank you for checking out my simple web pages.

I have removed several pages from my site that I really don't use that often. If you are looking for a link that is no longer here just [email](#) me and I will be more than happy to send you the link.

I have had several of my friends ask that I re-write my web-pages with fancy effects. After long thought I decided that I like to keep it simple. Faster load time and less distractions. If you would like to see more styles with frames and spinning logo's drop me a [note](#). If we get enough I will make some changes. Laura has done some very nice work in web designs. to see some take a look at [Ingasbo](#). We are also working on [Autumn Creek](#). Take a look to see at a work in progress.

Currently I am working on my MCSE (Microsoft Certified System Engineer). After working with NT for over a year it was time. I have just completed NT Server 4.0 test, Workstation class and Server in the Enterprise tests. The TCP/IP class was fun now to take the test!

At my place of full time employment, I maintain a network with Novell, NT, OS2, Linux and UNIX servers. In my off time I help several small business with their networks. As everyone knows the [Y2K](#) is becoming a higher priority and Henson Consulting is there to help evaluate PC's and apply the software patches from major vendors.

Other issues that we help with is teaching [data backup](#) strategies and disaster recovery planning. Many of our clients have had poor or no data backup before we were called to help. Just remember your insurance payment won't be able to replace your customer records.

[Computer tips](#) for Novell, DOS, Windows 3.1 and 95/98 at [PUD #1 of Kitsap](#), the place I work. I will also write pages on anything else that fancies me. So check every now and then to see the latest.

Links

[Network Professionals of Puget Sound](#) | [Interim Books](#) | [Washington State Gymnastics Home Page](#) | [Ingasbo](#)

SCA Links

[Spirit Makers Guild](#) | [SCA Missile Combatants](#) | [Barony of Dragons' Laire SCA Inc](#) | [The Kingdom of An Tir Infoscroll](#) | [Current Middle Ages](#) Web Server | [Autumn Creek](#) gifts

Soon to come to a viewer near you will be articles like:

Bowyerling (that is making archery equipment), with my efforts in learning how to do it! Located on My [SCA Marshalling](#) homepage.

Brewing and what our local brew club is doing. Also Located on My [Spirit Makers Guild](#) homepage.

If you find a link that is not working or just to give me feedback, I can be reached at mhenson@telebyte.com

Thanks for stopping by.

Disclaimer: This web-page is maintained courtesy of Matt and Laura Henson. The Henson's do not assume any liability for the accuracy of information contained on this page nor the suitability of any materials linked to this page.

copyright 19 Jun 2000

Matthew T. Henson



Professional and Personal Resume'

Certified NetWare Engineer (CNE) 1993, re-certified 26 June 1996

Microsoft Certified Professional (MCP) March 1999

Currently working on Microsoft Certified Systems Engineer (MCSE) 3 tests down 3 to go

1993 to present - Public Utility District #1 of Kitsap County Washington. - Data Network Manager

1992 to present - Henson Consulting, Small Business Network Administration.

1989 to 1993 - Barlows Electronics Inc. - Computer Repair Technician, Computer Consultant, Tutor, and Salesman.

1989 - Communications West - Voice Mail System Installer and Salesman

1979-1989 - United States Navy - Petty Officer First Class Electronics Technician (Submarine Qualified), Reactor Controls Division Work Center Supervisor, Engineering Department Training Coordinator, Automated Data Processing Security Officer, Nuclear Reactor Operator.

1976-1979 - Actor, Stage hand, Stage Manager, Lighting Designer, Scenery Shop Foreman.

My background includes experience which provides direct working knowledge in the following areas:

- Staff supervision, scheduling, evaluation
- Formal instruction, lesson plan development, lecture presentation, technical proficiency certifications
- Administrative responsibilities including records, reports, material history and personnel qualifications
- Budget development and tracking
- TCP/IP Management, File Management
- Developing Automated Data Processing Microcomputer systems for hardware/software security and accessibility, Firewall Administration

- Well-developed communication skills, written and oral.
- Proven leadership abilities.

Extensive experience in the following operating systems

- Novell versions 1.5 through 5.1
- Microsoft DOS 2.2 through 7.0
- Microsoft Windows versions 1.0 to Win95/98
- Microsoft Windows NT ver4 Workstation and Server
- Linux

Some experience with

- UNIX
- Xenix
- OS2

Provide help desk for many programs including

- Microsoft Office
- WordPerfect
- Email, Internet and Intranet
- Connectivity
- Scheduling software
- Desktop Publishing software

Member of Seattle Chapter of Network Professionals of Puget Sound (NPPS) 1996 to present

Networking Professionals Association (NPA) 1992 to 1997

Member of Kitsap Regional Telecommunications Committee 1999 to present

Founding Board Member of West Sound Technical Association 2000

Last Modified: Monday, June 19, 2000

[Master Index Page](#)

If you find a link that is not working or just to give me feedback, I can be reached at

mhenson@telebyte.com

Thanks for stopping by.

Year 2000 Page

As the year 2000 approaches the media hype starts to increase. Yes there is some problems with the computers and software concerning the transition from 31 December 1999 to 1 January 2000. However I believe that the real problems are being fixed and the problems that we will see are the product of fear and lack of understanding.

Health and safety items are getting addressed. I foresee that the real problems on January 1 will be only a minor inconvenience. I have been identifying and fixing problems for the last two years. Most of the computers I deal with are fixable. Now I do not work with Mini/Main Frames but with PC's.

I won't talk about the government your utilities or other outside entities. Rather I will talk briefly about small business and home computer systems.

First of all back up your data. Not just once but on a regular schedule. If you do not have a zip drive or tape backup I recommend that you get one. It really is good insurance. If you do not know how to implement a backup schedule then please read my [backup plan](#) page. If you plan on using a zip drive many of the ideas that I outline may require babysitting.

Upgrade your software to the latest release. Test your PC. There are several ways to test your hardware. See the links below on how. Take a look at the data you have now. If you just surf the web or use a word processor you do not have much to worry about. If you track date related data like your IRA or balloon payments then you may need to change your date data to have a 4 digit year. Make sure that you test each change that you make for the current year as well as setting your computer for some date in the year 2000, and 2001.

The links below are good source for more information on the Y2K Issues.

[The Year 2000](#) Information Center

Washington State [Y2K Information & Links](#)

[Westergaard Year 2000](#)

[BECRC Year 2000 Issues Y2K Y2000 resources](#)

[Microsoft TechNet - Year 2000](#)

If you find a link that is not working or just to give me feedback, I can be reached at mhenson@telebyte.com

Thanks for stopping by.

Disclaimer: This webpage is maintained courtesy of Matt and Laura Henson. The Henson's do not assume any liability for the accuracy of information contained on this page nor the suitability of any materials linked to this page.

Last Modified: Tuesday, February 16, 1999

Backup your data!

Not just once but on a regular schedule. If you do not have a zip drive or tape backup I recommend that you get one. It really is good insurance.

Here is a short description of a back up plan that I recommend. It requires about twenty backup sets a year. Five are active the rest are off site archives. I use the term "sets" as one backup may exceed one tape or zip disk. For the sake of clarity I will refer to each set as a single tape.

I recomend that you do a complete backup of your hard drive. Yes I said the entire drive. You only need to do this once and then only after you install or remove software. After that you should backup your data. Take your "Total backup" to an offsite location like your neighbor or good friend.

Label the first five sets as one, two, three, four, and the fifth one as daily.

Keep your data in an easy to find place. If you have Windows 95/98 then you have a directory called My Documents. A good place to keep all your data together. Save your files here. If you have programs that save data elsewhere (like Quicken) make a note of the directory name where your data resides.

On Friday night or early Saturday morning (if you have an automated tape backup software) backup all you data directories to tape set number one.

Monday night set up tape "daily" to backup data that has changed since set one. This is called a differential backup in your software. I set this to tape to erase before backing up. Repeat the schedule for Tues, Wed, Thur, but set the tape to append.

Friday morning as you are getting your cup of coffee eject your tape and and put in the next numbered tape.

On the first Monday of each month take the Friday tape to an off site location. Make sure that you date it! Get a new tape and label it with the number you took off site.

Thats how simple it is. Just takes some time to incorprate it in your schedule.

You should also test that you can recover data from the back up at least once a quater and more often if you find a problem. When you test the restore function I recommend that you create a dummy directory and a few un-important files in it. Back up as laid out above. Then delete the dummy directory. Check that the directory is indeed gone. Then try to restore the directory that you deleted. If you can not seek some help.

Backups are very important part of your computer use. Most people don't do any type of backup. When their computer hard drive crashes or some other major problem occurs and there is no back up. The data is gone forever. Customer data, Checkbook, Your great novel all gone or at best, days to re-create. If the worse happens such as a fire or flooding (this includes the upstairs bathroom tub running over and soaking your PC) or something that destroy's your residence or place of business and you have an off site backup then you can restore you data. When your insurance payment comes in all you need is a new computer with the same backup device that you had.

If you find a link that is not working or just to give me feedback, I can be reached at mhenson@telebyte.com

Thanks for stopping by.

Disclaimer: This webpage is maintained courtesy of Matt and Laura Henson. The Henson's do not assume any liability for the accuracy of information contained on this page nor the suitability of any materials linked to this page.

copyright 14 May 1999

THE GUILD

The guild does not just do beer. That's just where we currently have the talent. Meetings are usually on the third Monday of each month with occasional meetings as required.

At each meeting we have samplings, but you do not have to drink to participate. We do this to educate our palates. Most meetings are working meetings with brewing bottling or vinting. Specifically there are no dues but contributions are appreciated. this is to cover expenses like prizes for contests and projects like the Baronial brews so far.

- [Barony of Dragons' Laire SCA Inc](#)
- [The Kingdom of An Tir Infoscroll](#)
- [Current Middle Ages](#) Web Server



Links to points in this page

- [Most recent meeting notes](#)
 - [SCA Alcohol Policy](#)
 - [Disclaimer](#)
-

The Most Recent Meeting

I am way behind on my meeting notes being posted here. Hopefully I will get caught up in the next couple of days.

Remember "Drink responsibly!"

SCA Alcohol Policy

&

SCA Insurance Policy

(as issued at the Seneschal's meeting Autumn Crown Council November 8, 1997)

SCA, INC--As per SCA Policy, it is prohibited to use any SCA funds for the purchase of alcohol This includes the USA and Canada.

This includes the following:

1. For use as Prizes in tournaments or raffles
2. As gifts
3. For re-sale at Taverns, Bar's or Inn's
4. Or given away at a Tavern, Bar or Inn

Any donated alcoholic items for any of the above reasons is also prohibited. SCA Funds are permitted for the

following:

1. Alcohol purchased for use in cooking.
2. The purchase of equipment and ingredients by Guilds. for the study and recreation of alcoholic recipes, as long as it does not fall under one of the four reasons listed above.

Failure to adhere to this policy will cause the SCA Insurance Policy to become null and void at an event. This only applies to the USA and all it's territories.

AS PER SCA INSURANCE POLICY--It is prohibited under the Insurance Policy for the SCA to participate in any of the following:

1. The Manufacturing of Alcohol
2. The Distribution of Alcohol
3. The Selling of Alcohol
4. The Serving of Alcohol
5. The Furnishing of Alcohol

The Manufacturing of alcohol for an A&S Competition is permitted as long as the following applies:

1. No SCA Funds were used
2. The competition is being judged by persons qualified in that field
3. Competition is held in a controlled area

always, Modern Laws apply regarding minors with alcohol

An Tir Alcohol Policy

SCA insurance will defend the SCA on host liquor liability claims relating to the incidental use of alcohol at events, but not if we go into the business of selling the stuff.

SCA sponsored taverns are not allowed where the branch is serving alcohol. The risk of a tavern-keepers' lawsuit is more than the SCA can stand.

A. Minors with alcohol will not be tolerated. This means that a minor with alcohol will be told to leave the site immediately. The minors guardian/parent will be required to leave the site with the minor. No exceptions. failure to comply must be followed by a call to the police.

B. If the minor is on site without a parent or guardian, the constables responsible for granting access to that minor must be warned such action is a violation of duties. The minor must become sober and then told to go home. No exceptions. Failure to comply must be followed by a call to the police.

C. If the minor is 18 years of age but under 21 years of age and on site without a parent or legal guardian (as none would be required in most jurisdictions at that age) the minor must become sober and then told to go home. No exceptions. failure to comply must be followed by a call to the police.

D. if a minor came to the event with other participants who are not drunk but are the minors sole source of transportation - all in said vehicle must be told to go home with tile

minor. No exceptions. failure to comply must be followed by a call to the police.

E. If the person with alcohol is not a minor but disruptive to the event and its participants (reasonability issues apply here) the person must be told to go home - by means of a sober driver or cab or given time to sober up and then told to go home. No exceptions. failure to comply must be followed by a call to the police.

Spirit Making links

Recipies

- [Baronial Beer batch 1](#) |
- [Baronial Beer batch 2](#) |
- [Baronial Beer batch 3](#) |
- [Guild Mead batch 1](#) |

Minutes and Reports Have been moved off line

Other SCA related Links

- [SCA Missile](#) Combatants page that I maintain
 - SCA [Arts and Sciences](#) Homepage
-

Matt's SCA [resume](#)'

If you find a link that is not working or just to give me feedback, I can be reached at mhenson@telebyte.com

Thanks for stopping by.

Disclaimer: This webpage is maintained courtesy of Matt Henson. It is not a publication of the SCA, Inc. nor does it delineate SCA policies. Neither the SCA, Inc. nor Matt Henson assumes any liability for the accuracy of information contained on this page nor the suitability of any materials linked to this page.

Last Modified: Friday, May 14, 1999

copyright 1999

Baronial Batch for June Faire 1995

Bad Notes

May 8, 1995

We used

1 Can Geordie mild scottish Ale

3 lbs M&F dry malt amber

Boiled in Two Gallons of water for one hour

og= 1.054 @ 60F

May 14, 1995 Racked into second carboy sg= 1.020 @ 60F

May 15, 1995 Bottling day

Primed with 3/4 cup Corn sugar, 1 pint of water

Bottled 48 20oz Bottles with sg 1.015

Presented at June Faire 1995

Everyone thought it was great. The guild thought it was too young

If you find a link that is not working or just to give me feedback, I can be reached at

mhenson@telebyte.com

Thanks for stopping by.

Last Modified: Sunday, October 04, 1998

Baronial Batch for Candlemas

Started 18 Dec 1995

Recipe by Derek Lyons (aka Lord Theodoric the Scholar), Chuck Babcock, Matt Henson (aka HL Mateusz z Plocka)

1 Can Geordie mild scottish Ale
3 lbs M&F dry malt amber
1/4 lb roast barley light 350L
1/4 lb roast barley dark 500L
2 lbs crystal Malt 20L
1/4 lb chocolate malt 350L
W yeast 1028 London Yeast culture

Put grain in 2 grain bags split evenly
18:25 put to steep in 2 gallons 158 F water
18:32 stirred
18:40 stirred
18:55 Shifted grains to spare tub
19:00 2 gallons water added to brew kettle
19:04 added malt extract to Brew kettle
20:00 removed kettle from heat. placed in Cold water bath
20:05 Added Ice to sink
20:15 poured into Primary og 1.032 at 70F

27 Dec 1995 sg 1.027 at 70F
3 Jan Bottled
Conditioned between 60 to 65F

Opened first bottle 10 Feb 1996

19 Feb 96 Tasted and Judged at Dragons Laire Spirtmakers Guild
Need to add hops for better balance.

If you find a link that is not working or just to give me feedback, I can be reached at mhenson@telebyte.com

Thanks for stopping by.

Last Modified: Sunday, October 04, 1998

Baronial Batch for June Faire 1996

Started Mar 23, 1996

Recipe by Derek Lyons (aka Lord Theodoric the Scholar), Chuck Babcock, Matt Henson (aka HL Mateusz z Plocka)

Ingredients

1 Can Geordie mild scottish Ale
2 lbs M&F dry malt amber
1 lbs Wheat DME
1/4 lb roast barley 350L
1oz roast barley dark 500L
1 lbs crystal Malt 20L
1 lbs Special B 190L
1/4 lb chocolate malt 350L
1 oz Black Patent
1/2 oz Willamette Hops
1/4 teaspoon Irish Moss
W yeast 1028 London Yeast culture

14:11 Started the Steep

14:42 Started the Sparge

NOTE: Don't use a small pot. We used a 2gal pot and the bags displaced half of the volume.

14:45 End sparge

15:06 Added extract

15:35 Start boil and added 1/2 oz Willamette hops

15:50 Added Irish moss

16:35 End Boil, Began chilling in ice bath

17:36 og= 1.055 at 60 degrees F Pitched Yeast

March 4, 1996 Racked 5 full gallons sg=1.020 @60F

Costs of Brew

\$ 2.00 Ice

\$26.29 Grain

\$ 2.00 Hops

\$11.00 Bottles

\$ 4.00 Yeast -----

\$45.29 Total

Donations from Guild Members \$25.00 to date Mar 5, 1996 (Derek and Matt still need to be re-embersed)

If you find a link that is not working or just to give me feedback, I can be reached at mhenson@telebyte.com

Thanks for stopping by.

Last Modified: Sunday, October 04, 1998

Guild 5 year Mead

October 16, 1995

Boiled 2 gal Water and added 16+ cups of Raw Blackberry honey (aproximently 12 lbs)

Boiled for 30 Minutes skimming

Added 2 tsp yeast nuterient, 4 tsp acid blend.

Cooled to room temp with water and ice bath

Made starter with Prisse yeast at 90F

added 2 gals to carboy and added the must

og=0.068 @ 60F

March 9, 1996 Racked with Sparkloid (fining agent)

sg= 1.000 @ 57F

March 18, 1996 Bottling day, sg=0.997 @ 60F

Bottled 24 Wine bottles and Named the "Stumbling Bumble Bee"

If you find a link that is not working or just to give me feedback, I can be reached at

mhenson@telebyte.com

Thanks for stopping by.

SCA Missile Combat

Last Modified: Sunday, October 04, 1998



Alpine Pass War 1989

Jump point

[Master Index Page](#) | [Spirit Makers Guild](#) | [Draft AnTir One-On-One Combat Rules](#)

Links to points in this page.

- [Non-Contact Combat](#) WAR!
 - [Bowerying](#) Longbows
 - [Other Archery pages](#) both SCA and Not
 - [Disclaimer](#) yes I have one too.
-

Missile Combatants

I have just finished writing a new page for [Tennis Ball Launching Crossbows](#). Please take a look at it and let me know what you think.

We recently held war practice at my home on Sunday, All Dragons Laire citizens are encouraged to support you troops!

Tennis balls are available to anyone in the Barony. If I am at the war and you need some just ask. If you are planning to go to a war and I am not, just call and I will arrange to get them you.

Work is progressing on the [tennis ball crossbows](#) I am making for tourney season. I plan to have more than one with me at any war I am going to. If you show up and THEY decide at the last minute no Arrows see me!

I have gone out with my equipment and determined the ranges each performs at. I shot 12 times with each weapon into the wind and with the wind. Here is what I have found.

What range and accuracy do you get with your combat arrows.

1) Type and weight of bow: eg solid fiberglass, laminate recurve, crossbow, etc.

1. Tennis ball cross bow 35# at 17" for 595 inch pounds made from lumber and rubber tubing.
2. Fiberglass recurve 25# at 28" draw

3. Wood fiberglass laminate recurve 30# at 28" draw

2) Type of combat arrow: Golf tube, tennis ball or thrusting head.

1. unaltered tennis balls (moderately flat)

2. ii) and iii) Wood shaft, 3/4 inch blunt

3) Maximum range at 45 degree angle.

1. Average 34 yds

2. average 63 yds

3. average 84 yds

For comparison I shoot 12 wood shafted target arrows both with and against the wind for an average of 107 yds.

4) Maximum range at which you can <usually> hit a fighter.

1. 20 yds

2. 35 yds

3. 40 yds

I have found that I can hit where I want more in armor on a war field than I can on a royal round.

5) Best range for <almost always> hitting a fighter.

1. 20 yds

2. 25 yds

3. 30 yds

6) If you have used both golftubes and woodshaft, how would you compare them?

One time effort using some else golf tubes at AnTir/ West

1. na

2. no range could'nt even get close enough.

3. maybe 10 yds.

Even though I have short range with the tennis ball crossbow, I have more heavies acknowledge the hits. The low cost of the weapon and ammunition make it less painful to play. I can play in more battles than shafted weapons. My opponents do not need screening. The disadvantage is I do a lot of running. Too easy to get too close to heavies engaged in combat. takes about twice as long to reload and fire than shafts but I am working on that.

[Top of page](#)

[Jump point](#)

Bowerying

I am really enjoying making strings. Getting ready to start a few kid's bows. I found a hard wood store in Seattle that I can buy seasoned kiln dried wood. I figure for about \$30.00 I can get two bows out of some Ash. That is as soon as I can talk a friend into cutting the boards with his band saw.

I have completed my first bow of Oak. Learned a lot about wood in making it. but I over tillered and it is now a 15 pound kids bow.

My original intention was to make a period style long bow with a 30 pound pull at 28". What I ended up with is a bow that is an over tillered replica of a Frankish flatbow. The bow is similar to the dimensions as the Asby-Stigoma find dated between 400 and 700 A. D. The bow is un-backed Spruce that is man height.

I started off by going to a bow making class taught at [Pacific Yew, Inc.](#) (Northwest Archery) by Jay St. Charles. And then reading everything I could. When I felt brave enough I spent several days visiting many lumber yards searching for a suitable wood and grain structure. The early bows of Europe were made from Yew, Elm, Spruce, and Oak. I did find a 2 by 2, eight foot piece of straight grained Oak.

After picking the best six feet of the board and cutting it to height, I then used a draw knife to bring the bow to life. By

using the Draw knife upside down I was able to shape the bow and follow the growth rings. I then began to use a spoke shave to further tiller the bow and shape the riser section. When the bow felt ready and floor tillered evenly I cut the string notches with a file. I started using a tillering stick to match the limbs curves. By paying too much attention to the shape of the bend I lost the desired weight. I was down to a five pound pull. To compensate I started removing length. The Bow is now 6 inches shorter and I brought the pull to 13 pounds at 28". A good kids bow.

I then used a scraper to remove most of the tool marks. To polish the bow before applying the finish I used a glass bottle. The olive bottle is about the same shape of a polishing stone. Then I used a wet towel to raise the grain and ran the scraper over the entire length again. After repeating the process of damping, scraping and polishing three times I was no longer in danger of raising splinters.

The finish is commercially available as Tru-Oil, a linseed based finish used on gun stocks. I then buffed the bow with steel wool and 400 grit sandpaper after each of 10 coats. I then cut and glued the handle and arrow rest to the bow.

I picked up a 10 foot 1 by 4 of Elm for another try. The cost was \$15.00, a good start. From this piece I was able to make one bow at 25# for my nephew, Broke one while tillering it, and Currently working on the third and final bow I could get from the board. Not too bad eh.

[Top of page](#)

[Jump point](#)

My Schedule (or where I have been)



An Tir/West War 3-6 July, 1997



This is me at Master Ed 1996



[Top of page](#)

[Jump point](#)

Other Links

- [SCA Archery](#) Homepage
- [SCA Archery](#) mailing list home page
- [Archery](#) This is a collection of Rialto (rec.org.sca) articles made by Stefan li Rous
- [Rialto](#) Archive This is a collection of Rialto (rec.org.sca) articles made by Stefan li Rous
- [Historic Enterprises](#) Great for Armor ans some other stuff.
- [Kingdom of An Tir - An Tir Book of Combat](#)
- [Home-built Crossbows](#)
- [DETAILS AND OPTIONS](#) Crossbow's
- [Timber Framers Guild: Report on the Trebuchet Workshop](#)

Non SCA but good

- [Gold Fox](#) Traditional Archery
- [Ryan Herco Products Corporation](#)[Home Page] Possible source for shafts
- [\(Ted Nugent World Bowhunters\)](#)The official Ted Nugent World Bowhunters pages, with Nugent biography and (soon we hope) stuffed with stuff.
- [Maryland Archery](#) (Kennesaw Archery Club) The pages have club information, tournament schedule and tournament results.
- [Pacific Yew, Inc. -](#) - Maker of fine yew longbows
- [Traditional](#) Bowsites

If you find a link that is not working or just to give me feedback, I can be reached at mhenson@telebyte.com

Thanks for stopping by.

Disclaimer: This webpage is maintained courtesy of Matt Henson. It is not a publication of the SCA, Inc. nor does it delineate SCA policies. Neither the SCA, Inc. nor Matt Henson assumes any liability for the accuracy of information contained on this page nor the suitability of any materials linked to this page.

[Jump point](#)

[Top of page](#)

Draft AnTir One-On-One Combat Rules

DRAFT - FOR DISCUSSION PURPOSES ONLY

9 May 1998

Rules for Missile Combat Tournaments

By H. L. [Eric de Dragonslaire](#), OGGs, An Tir Royal Archer

These are the rules for the An Tir Kingdom Protector Tournament and for standardized one-on-one missile combat tournaments within the Kingdom of An Tir.

THE ERIC:

Combat shall take place in two squares, 10 feet by 10 feet, which be set up so that the distance from the back of one square to the back of the other is 20 yards. (Make sure that the poles used to hold the ropes do not pose a threat to the combatants should they fall on one.) The eric will be centered in a 20 yard by 60 yard overshoot area where no one other than authorized marshals will be permitted during combat. It is recommended that the overshoot area be demarcated, preferably by roping the area off so that spectators do not stray into the area. Spectators should not be permitted along the short ends of the field.

ARMOR AND WEAPON STANDARDS:

All combatants must wear light combatant armor that meets the standards set in the An Tir Book of Combat. Only missile weapons that meet the standard set in the An Tir Book of Combat may be used; except that experimental missile weapons may be used if approved by the marshal in charge and the person's opponents do not object to the use of the experimental weapons. A combatant may only use weapons that they are authorized to use.

Each combatant may carry up to 12 missiles with them into the eric; e.g., 12 arrows, or 11 arrows and one throwing axe, or 6 tennis balls and 6 javelins, etc.

Each combatant may carry only 1 projectile launching piece of equipment; e.g., a bow, crossbow, stone bow, or staff-sling, etc. One buckler may be used, provided it is not greater than 15 inches in any dimension.

All armor, weapons and ammunition must be inspected by a warranted light marshal prior to each tournament.

The minimum sized blunt on combat arrows shall be 5/4 inch. Arrows shall be inspected prior to each fight by the contestant or a light marshal.

COMBAT:

The rules of the lists shall be enforced. Contestants must show their authorization card when signing up for the lists.

Upon the Marshal's command of "lay on" fighting shall commence. Prior to lay on arrows may be nocked, but not drawn; crossbows and stonebows may be drawn and loaded, but must be pointed groundward; and hand weapons may be at the ready (the arm may be cocked). A fighter wins the battle by killing the enemy, having their opponent step out of the square during combat or scoring more points.

If a combatant steps out of the square, the combatant is considered to have lost. This is at the marshal's discretion and should be judged leniently. (It is very difficult to see the lines at one's feet while wearing a helm and watching one's opponent.) If a bow is struck, it is considered to be broken, and must be discarded.

If a quiver is struck by an arrow, one arrow is considered to be broken, and must be removed from the quiver and not loosed at the opponent. If it is struck by a javelin or throwing axe, all the arrows are considered broken. Note that arrows and bolts are damageable, but javelins, throwing axes, and rocks (from a staff sling or stone bow), are not vulnerable.

An arrow hitting the ground for any reason is dead for that fight. Other projectile weapons that are dropped must be re-inspected by the combatant before being used.

The entire body is a legitimate target, from toes to fingertips (it is recommended that combatants do not intentionally shoot at the bow hand or groin). A hit to a limb disables that limb. A hit to the head or torso kills. If both combatants run out of missiles without either one being killed, the winner shall be determined by points. An arm or a leg being disabled counts as a point. Multiple hits on the same limb do not score multiple points. Shots that hit a stray piece of cloth do not count as a hit. A bow hit does not count as a point. Thrown arrows or rocks do not score.

If points are equal at the end of combat, or if a double-kill occurs, the bout is considered a tie. A tie is re-fought, then if a tie occurs on the second bout, both combatants are considered to have lost.

MARSHALS:

The marshal in charge of the tournament must be a warranted junior or senior light marshal. Marshals must wear a minimum armor of a light helm or three weapon fencing mask. Full light armor is recommended.

Marshals shall bear fair witness when requested. The marshal in charge of the tournament shall declare before the fighting begins what type of tournament it is; e.g., round robin, double elimination, triple elimination, etc.

If you find a link that is not working or just to give me feedback, I can be reached at mhenson@telebyte.com

Thanks for stopping by.

Disclaimer: This webpage is maintained courtesy of Matt Henson. It is not a publication of the SCA, Inc. nor does it delineate SCA policies. Neither the SCA, Inc. nor Matt Henson assumes any liability for the accuracy of information contained on this page nor the suitability of any materials linked to this page.

SCA Resume'

In 1976 my wife Laura (then girlfriend) told me about an SCA event that she had been to, in fact she had attended two events. Immediately we began searching for a chapter of the SCA in that town. In 1987 We found Dragons' Laire and our hearts had found their home.

I hold my Lady with the highest regard and carry her favor with honor.

There for I put my SCA Resume' forth

HL Matuesz z Plocka

Joined the SCA and Dragons' Laire in 1987 AS XXI

Offices and Jobs

Seneschal of Dragons' Laire Apr. 1990 to Aug. 1992

Dragons Laire Spirit Makers Guild head 1994 to present.

Commander of Lights for the Barony of Dragons Laire 1995 to present

Baronial Constable July 1996 to 1998

Autocrat

May Crown 1991

June Faire 1993

Barony of Dragons Laire Sargentry Yeoman Gallant trials 1996

Qualified

Senior Lights Marshall

Junior Heavy Marshall

Senior Constable (Teaching) at large

Apprentice level Archer

Skills

Maker of Mead's and Beers.

Apprentice level Bowyer (maker of Bows, Arrows etc.)

Awards

- Award of Arms -1991
- Order of Goute de Sang - 1992
- Dragons Laire Wyvern Service Award - 1992
- Kingdom Constabulary Award 1995
- Bumble Bee Award for Spirtmaking 1996
- Snapdragon Baronial Service Award 1996
- Baronal Arts and Sciences Champion 1996-1998

- Jambe de lionne 1998

Last Modified: Saturday, January 30, 1999

[Master Index Page](#)

If you find a link that is not working or just to give me feedback, I can be reached at mhenson@telebyte.com

Thanks for stopping by.
