



**INSTRUCTION MANUAL
for**

RUGER®

*Over and Under Shotgun
20 & 12 gauge*

BLUED AND STAINLESS STEEL



NOTE: This model out of production
– For reference use only.

**READ THE INSTRUCTIONS AND WARNINGS
IN THIS MANUAL CAREFULLY
BEFORE USING THIS FIREARM**

**THIS INSTRUCTION MANUAL SHOULD ALWAYS ACCOMPANY THIS FIREARM
AND BE TRANSFERRED WITH IT UPON CHANGE OF OWNERSHIP,
OR WHEN THE FIREARM IS LOANED OR PRESENTED TO ANOTHER PERSON.**

**STURM, RUGER & Company, Inc.
Southport, Connecticut 06490
U.S.A.**

**ALL RUGER FIREARMS ARE DESIGNED AND MANUFACTURED
IN RUGER FACTORIES IN THE UNITED STATES OF AMERICA**

OU1 & OU3/4-95RI

FIREARMS SAFETY—YOUR RESPONSIBILITY

SAFETY MUST BE THE FIRST AND CONSTANT CONSIDERATION OF EVERY PERSON WHO HANDLES FIREARMS AND AMMUNITION.

This Instruction Manual is designed to assist you in learning how to use and care for your Ruger shotgun properly.

Only when you are certain you fully understand the Manual and can properly carry out its instructions should you practice loading, unloading, etc. with live ammunition.

If you have any doubts about your ability to handle or use a particular type of gun safely, then you should seek supervised instruction.

Such personalized instruction is often available from gun dealers, gun clubs or police departments. If none of these sources can help you, write to the National Rifle Association, Washington D.C. 20036. They will assist you.

The person with a gun in his possession has a full-time job. He cannot guess; he cannot forget. He must know how to use his firearm safely. *Do not use any firearm without having a complete understanding of its particular characteristics and safe use.* Remember: There is no such thing as a foolproof gun.

TABLE OF CONTENTS

	Page
Mechanical Characteristics.....	3
Ammunition.....	4
Cross Section Drawing of Mechanism.....	5
Assembling the Shotgun.....	6
Takedown Procedure.....	7
Operation of the Shotgun.....	7
To Load and Fire.....	8
Installation of Screw-In Choke Inserts.....	9
Steel Shot.....	10
Care and Cleaning.....	10
Service and Parts Policy.....	11
Parts Drawings.....	16 & 17
The Basic Rules of Safe Firearms Handling.....	18
Warranty Information.....	20

WARNINGS OF GREAT IMPORTANCE ARE FOUND ON THE FOLLOWING PAGES:

Alteration.....	2	Safety Mechanism.....	8
Ammunition.....	4	Screw-In Choke.....	9
Takedown and Disassembly.....	7	Lubrication.....	11
Bore Obstructions.....	7	Parts Purchasers.....	12
Firing.....	7		

ALTERATION WARNING

Sturm, Ruger & Company, Inc. will not be responsible for *any* alteration of *any* part of this firearm after it leaves our control, or for the addition or substitution of parts or accessories not manufactured by Sturm, Ruger & Company, Inc. This product was designed to function properly *in its original condition*. Any changes made in this product are specifically contrary to our instructions and we expressly do *not* authorize any changes to be made after manufacture. *Do not jeopardize your safety or the safety of others by making modifications to your firearm.*

FIREARMS ARE DANGEROUS WEAPONS—READ THE INSTRUCTIONS AND WARNINGS IN THIS MANUAL THOROUGHLY AND CAREFULLY BEFORE USING THIS FIREARM

THE RUGER OVER AND UNDER SHOTGUN 20 & 12 Gauge MECHANICAL CHARACTERISTICS

THE ACTION

The trigger mechanism includes a *hammer interrupter* which directly blocks the hammers if either or both are cocked and the safety is engaged. With the safety off, the hammer interrupter can be lifted clear of the hammers only by a deliberate pull of the trigger. A complete release of the trigger is necessary to set the gun for firing the second shot. The automatic top safety also serves as the selector that determines which of the two barrels is to be fired first. The conical pointed firing pins are strongly proportioned and will not be damaged by dry-firing.

THE BARRELS

The barrels are hammer-forged, stress relieved, contour ground and precisely fitted and silver brazed to the finished monobloc. The dovetail hollow rib is securely silver brazed to the top barrel and machine-cut cross serrations in the top surface of the rib provide a matte, glare-free sighting plane. The front sight is a standard gold bead. Patented barrel side fillers are attached by simple mechanical means and can be removed if desired.

THE WOOD

The stock and semi-beavertail forearm are made from first quality straight grain American walnut, fully seasoned, with deep hand-cut checkering of 20 lines to the inch. An improved forearm wood-to-metal assembly provides a broad recoil surface. A pistol grip and rubber recoil pad are standard and all wood surfaces are sealed with a satin weather-proof finish.

SPECIAL FEATURES

The Ruger 20 & 12 Gauge *Red Label* over and under shotguns are now offered with a stainless steel receiver. The trigger, and forend iron of this model are also made of stainless steel with an attractive brushed satin finish. The trigger guard, top lever, and safety thumbpiece, as well as barrels, are of heat-treated chrome-molybdenum steels, polished overall and blued. This combination offers the sportsman the unique advantages of rust-resistant stainless steel in a shotgun which is known for its advanced design, slim lines, perfect balance, and classic styling.

The *trunnions* on which the barrels pivot are mounted high, close to the centerline of the lower barrel, and are integral with the receiver. This is the only gun in the world of which this is true.

In addition to trunnions, a massive *square lug* at the bottom rear of the monobloc locks into the thick bottom wall of the receiver to provide extra security for the barrel-to-frame lock-up.

Projecting from the rear end of the barrel assembly, one on either side, are two heavy, integral heat-treated *lugs* which are engaged by the locking bolt as it slides forward when the gun is closed. The locking bolt is, in effect, a wedge due to the angle of the locking faces. These faces have more than adequate area and are hardened and precision ground.

The *hammers* are of the rebounding type. After firing, they move back from the firing pins enough to clear them and are held in this position by the mainspring. The rebound position of the hammers means that their cocking motion is not started until after the barrels are partially opened, and this contributes materially to the easy opening of the gun. The hammers cannot fall completely forward to reach the firing pins unless the locking bolt, which lies directly ahead of them, is in its forward position when the barrels are locked shut in the frame.

The *top lever* and its massive pivot are one integral component directly engaged with the locking bolt both on opening and closing motions. The lever and the locking bolt are driven to the closed position by the top lever spring which, through its strut, retains the top lever in the gun.

The *mainsprings* and *rebounding hammer struts* have been engineered to provide optimum fire for all primers while minimizing the force required for cocking.

The *sliding safety thumbpiece*, in addition to its fore and aft motion, pivots to swing from side to side and thus incorporates the function of *barrel selector* in association with the single trigger mechanism. In its rear, or safe position, the safety mechanism locks the *hammer interrupter*—a unique characteristic of this gun. In this position it is impossible for the hammers to reach the firing pins. The hammer interrupter, in turn, locks the trigger against being pulled.

The *stainless steel trigger* lifts the sears successively by means of the *sear selector* which is pivoted on the trigger to allow not only the fore and aft movement for re-setting between shots, but also to permit a lateral positioning controlled by the swinging motion of the *safety thumbpiece*. If the thumbpiece is swung to its left side position and pushed forward, the sear selector is moved to the right and allows the top barrel to be fired first. If the thumbpiece is swung to the right side and pushed forward, the sear selector moves to the left and allows the bottom barrel to be fired first.

Under recoil, an *inertia weight*, pivoted on the lower tang, swings to the rear and, by means of a link, pulls the sear selector out of engagement with the sears. The sear selector is inoperative until the inertia weight returns to its forward position, so the gun is thus made safe from “doubling” (firing both barrels with a single pull of the trigger). This mechanism has proven to be extremely reliable and has the desirable feature of permitting the second barrel to be discharged even if the first pull of the trigger is a misfire. The second shot can be fired whether the gun has recoiled or not.

Provision is made in the stock for the *through-bolt* system of attachment which is strong and simple. The rear ends of the tangs interlock with the wood and the forward end of the stock is tenoned into recesses in the receiver to provide maximum strength and resistance to splitting or loosening.

The *automatic ejectors* assemble to the monobloc simply, without retaining pins or screws. The *ejector sears* are pivoted on *integral studs* in the forend iron.

AMMUNITION

The Ruger Over and Under Shotgun is chambered to use standard commercially manufactured 2¼” and 3” Magnum shotshells. This gun has been tested with special proof-test ammunition which conforms to U.S. industry practice. It is intended for use only with standard ammunition of the proper gauge and loading.

AMMUNITION WARNING

Firearms may be damaged, and death or serious injury to the shooter or other persons may result from any condition which contributes to the generation of excessive pressure, or the uncontrolled release of gas, within a firearm. The foregoing adverse conditions can be caused by *bore or chamber obstructions, propellant powder overloads, or by defective, incorrect, or improperly loaded and assembled shot-shell components.*

It is extremely dangerous to use a shotshell whose pressure is greater than that developed by shotshells loaded to Industry Standards. Even the strongest firearm can be blown up as a result of excessive pressure.

AMMUNITION NOTICE

WE SPECIFICALLY DISCLAIM RESPONSIBILITY FOR ANY DAMAGE OR INJURY WHATSOEVER OCCURRING IN CONNECTION WITH, OR AS THE RESULT OF, THE USE IN THE RUGER SHOTGUN OF FAULTY, OR NON-STANDARD, OR “REMANUFACTURED”, OR HANDLOADED (RELOADED) AMMUNITION, OR OF SHOTSHELLS OTHER THAN THOSE FOR WHICH THE FIREARM WAS ORIGINALLY CHAMBERED.

ASSEMBLING THE SHOTGUN

The Ruger Over and Under Shotgun is shipped taken down. To assemble, proceed as follows:

(1) After unwrapping the barrel/forearm assembly and receiver/stock assembly, wipe excess rust preventive oil from the monobloc and inside surfaces of the receiver. Swab the bore with a clean cloth patch on a cleaning rod to remove any excess oil.

(2) Pull outward on forend latch lever and pull wood forearm outward and forward, separating it from the barrel assembly as shown in Figure 2.

(3) To attach the barrel assembly to the receiver, hold the stock by the pistol grip in one hand as shown in Figure 3. Make sure the top lever is opened to the right in order to accept the barrel assembly. Hold the barrel assembly in the other hand and engage the integral trunnions in the receiver with the corresponding recesses at the front end of the monobloc. Be sure the small lugs (indicated by the arrow 'A' in Figure 3) on the outer surfaces of the ejectors engage their corresponding slots inside the front end of the receiver **BEFORE CLOSING THE GUN!** *The foregoing caution must be followed, otherwise the "ball" area of the receiver will be damaged by the ejectors as the gun is closed.*

(4) Swing the muzzle end of the barrels upward, pivoting the rear end of the monobloc downward to seat in the receiver as shown in Figure 4. The barrel assembly is seated and locked into the receiver when the top lever snaps to its centered position.

(5) Place rear end of the forend iron over the ends of the ejectors as shown in Figure 5, and swing the front end of the forearm upward until the forend latch lever catches the forend latch hook on the underside of the lower barrel, and the forend assembly snaps into its locked position.

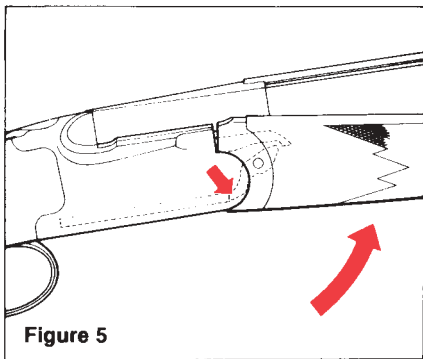
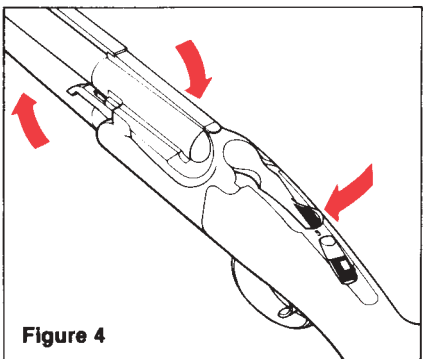
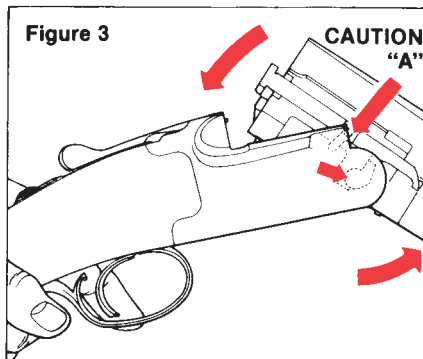
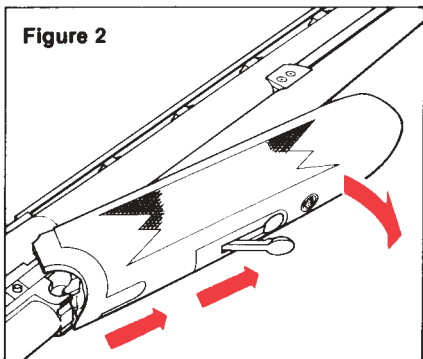

TAKEDOWN AND DISASSEMBLY WARNING

Never clean, lubricate, disassemble or work on a firearm while it is loaded.

TAKEDOWN PROCEDURE

To take down the Ruger Over and Under Shotgun, proceed as follows:

- (1) Check both chambers to be sure that the gun is *unloaded*.
- (2) Pull out the forend latch lever and separate the forend assembly from the barrels as in (2) above (See Figure 2).
- (3) Push the top lever all the way to the right and break the gun, pivoting the muzzle end of the barrels downward and lifting the barrel assembly out of the receiver as the integral trunnions are disengaged from their corresponding recesses at the front end of the monobloc.
- (4) Replace the forend assembly onto the barrel assembly by aligning the forend latch hook with the forend latch lever and snapping together.

This completes the takedown required for all normal cleaning and maintenance purposes. *Further disassembly of component parts should only be undertaken by persons qualified in shotgun repair and is not recommended.*

OPERATION OF THE SHOTGUN

Always check to be sure the gun is unloaded before handling, 'dry-firing', takedown, cleaning, or storage.

Every Ruger Over and Under Shotgun is inspected before shipment to ensure that it conforms to our standards of finish and performance. **WE ASSUME NO RESPONSIBILITY FOR ANY INJURY OR DAMAGES RESULTING FROM ITS INTENTIONAL OR ACCIDENTAL DISCHARGE.**

BORE OBSTRUCTIONS WARNING

Before loading or firing the gun, examine the bores to be sure that they are clear and unobstructed. *Firing the gun with any obstruction in the bores may result in damage to the gun and injury to the shooter and other persons nearby.*

A misfire or unusual report (sound) upon firing is always a signal to cease firing and immediately examine the chamber and bore of both barrels. Visually inspect the full length of the bores. If there is any obstruction—full or partial—clear the obstruction completely with a rod and bore brush before firing the gun.

FIRING WARNING

All persons must be a safe distance to the rear of the shooter when a shotgun is being fired. Particles of lead, powder, lubricant, and accumulated bore deposits can be blown in a wide area—particularly if the wind is blowing—into the eyes and face of the shooter and those nearby. For that reason shooters and bystanders must wear shooting glasses or similar eye protection. Hearing protection must also be worn because exposure to shooting noise can damage hearing.

TO LOAD AND FIRE:

- (1) With the gun assembled, move the top lever completely to the right and open the action.
- (2) With the gun opened, insert a shotshell of the proper gauge in each chamber.
- (3) Close the action and check to be sure it is securely locked and that the top lever is fully to the left in its centered position.
- (4) When you are ready to fire, move the automatic top safety thumbpiece forward to its 'off', or 'fire' position (*See Note which follows). The gun is now ready to fire.

WARNING: DO NOT TOUCH THE TRIGGER UNTIL YOU ARE ACTUALLY READY TO FIRE.

- (5) After firing the first barrel, the trigger must be allowed to return to its fully forward position to permit firing the second barrel.
- (6) After firing, move the top lever completely to the right to open the action and eject the empty shotshells. If the action is opened with unfired shotshells in the chambers, they will be elevated sufficiently to be easily extracted with the fingers.

*NOTE: The Ruger Over and Under Shotgun is provided with an automatic top safety. Whenever the action is opened, the safety automatically moves rearward to its 'on', or 'safe' position (the letter 'S' is visible forward of the safety thumbpiece on the top surface of the receiver). If the safety thumbpiece is moved forward (to cover the letter 'S'), the safety is in its 'off', or 'fire' position and remains in that position until moved back to the 'safe' position manually, or until the action is opened again.

Note that the letters 'T' and 'B' appear to the right and left of the safety thumbpiece, and indicate which barrel is to fire first. If the thumbpiece is moved to the right so that the letter 'B' appears, the *bottom* barrel will fire first. If the thumbpiece is moved to the left so that the letter 'T' appears, the *top* barrel will fire first.

NON-AUTOMATIC SAFETY AVAILABLE — The automatic safety in the Ruger Shotgun is generally desired for field guns. However, the automatic safety can be replaced by a *non-automatic* safety if the shotgun is returned to our factory as outlined in the 'Service Policy' section of this manual, page 11, item 7.

SAFETY MECHANISM WARNING

The automatic safety mechanism in this gun has been designed to be safe and reliable, however *we urge you not to depend on it!* The shooter should always be alert to the possibility of accidental discharge, regardless of the position of the safety thumbpiece. Never place a loaded gun against any object (wall, fence, vehicle, tree, etc.) because there is always the possibility that the gun will be knocked or jarred from its standing position and fall with sufficient force to be discharged. Do not drop or 'bang' the gun; and never strike any part of the gun, when it is loaded. Never store a firearm in such a manner that it may be pulled from a shelf or storage place as some other item is being moved. Never point the gun at another person, or allow the muzzle to point at any part of your body, whether the safety is on or not. The only safe gun is one in which the action is *open and unloaded*.

INSTALLATION OF SCREW-IN CHOKE INSERTS (for shotguns so equipped)

Make sure the shotgun is unloaded! Either open the action or dismount the barrels completely from the action assembly. Lightly coat the threads of both the barrel and the desired choke insert with good quality gun oil. Carefully start the choke insert into the barrel threads by hand, taking care that the choke insert is not cross-threaded. Using the choke insert key (supplied), carefully hand tighten the choke insert into the barrel until it is tightly secured in the barrel, and so that the choke insert is fully bottomed into its recess in the barrel. Take note which choke you are inserting into each barrel. Remove the choke insert key from the barrel after tightening. In the event you must later determine which inserts have been installed, engage the safety, *unload the shotgun*, and while the gun is hinged open, the identifying slots can be seen by glancing obliquely into the muzzle from the side.

To minimize the possibility of damage to the screw-in choke inserts and the barrel threads, it is recommended that a set of choke inserts be kept correctly tightened into the barrel at all times, including storage and cleaning. Cleaning the barrels without the choke inserts in place can push dirt and other fouling into the barrel threads, which will interfere with proper installation of the choke inserts.

Rifled Slugs — Do not fire slugs unless a choke insert is installed (see “Screw-In Choke Warnings”, below).

Steel Shot — Steel shot loads manufactured to U.S. Industry Standards can be used with Ruger screw-in choke inserts with no special precautions other than those listed above.

SCREW-IN CHOKE WARNINGS

Do not peer directly into the shotgun muzzles! This is dangerous and unnecessary to determine which choke inserts are in place.

Do not change choke inserts in a loaded shotgun, regardless of the position of the safety.

Never fire the shotgun if the screw-in choke inserts are not fully and tightly bottomed into the barrel threads, or if the inserts are improperly installed or “cross-threaded”, or if the threads of either the barrel or the choke insert are damaged. Under these conditions, the barrel will be damaged and the screw-in choke inserts can be propelled out of the muzzle with great velocity when the gun is fired, with resultant risks of property damage or injury to the shooter or bystanders.

Never fire the shotgun without the screw-in choke inserts in place. Doing so will cause an erratic shot pattern and may irreversibly damage the choke insert threads in the barrel, making correct installation of the screw-in choke inserts impossible without expensive re-barrelling. See immediately preceding paragraph.

Do not attempt to use screw-in choke tubes of any other make or manufacture in Ruger shotguns. They will not function properly. Do not attempt to alter or modify existing fixed choke Ruger shotgun barrels for screw-in choke inserts. This can seriously weaken the barrel and may be dangerous. See “Alteration Warning” elsewhere in instruction manual.

STEEL SHOT

All steel shot loads loaded to current U.S. industry specifications can be used in Ruger shotguns equipped with screw-in chokes.

In conventionally (non-adjustable) choked full choked barrels, the use of large size (F, T, BB and larger) steel shot can result in a very slight ring near the muzzle. It must be emphasized that this ring should have no adverse effect on pattern or shot velocity. As we have no control over the manufacture of ammunition which may be introduced in the future, we cannot be responsible for damage caused by steel shot loads.

Since steel shot generally patterns tighter than conventional lead shot loads, it would be wise to avoid the use of steel shot altogether in conventionally choked full choked barrels. Modified choke barrels generally deliver "full choke" patterns when used with steel shot.

We do not recommend *any* of our shotguns for use with *reloads*, steel shot or otherwise.

CARE AND CLEANING OF THE RUGER OVER AND UNDER SHOTGUN

Always check to be sure the gun is *unloaded* before cleaning.

TO CLEAN THE GUN AFTER FIRING:

- (1) Take down the gun. (See Takedown Procedure, page 7.)
- (2) Using a proper cleaning rod, run a solvent-wetted patch through each bore several times. Then run dry patches through the bores to remove all traces of residue. The bore, as referred to here, includes the chamber.
- (3) If the bore is leaded to the extent that the above patch-cleaning procedure will not remove the lead, then scrub the bore, full length, with a solvent-wetted brass-bristle brush. When the leading has been scrubbed loose, clean as described in (2) above.
- (4) The polished surfaces of the monobloc, ejectors, and inside surfaces of the receiver where the monobloc rests should be coated with a very light film of lubricating oil.
- (5) Reassemble the gun, and wipe exterior metal surfaces with a sparingly oiled cloth. Accumulation of oil tends to attract dirt which can interfere with the safe and reliable function of the gun. Swab the bores with an oily patch before storing the gun. *Do not apply excess oil.*
Do not store a shotgun in a leather scabbard. Leather attracts moisture even though it may appear to be perfectly dry.

PERIODIC MAINTENANCE:

At regular intervals, or whenever the gun has been exposed to sand, dust, extreme humidity, condensation, immersion in water, or other adverse conditions, take down and clean and oil as outlined above. Lubricate contact area of forend iron and receiver with *stainless steel* lubricant. Proper periodic maintenance is essential to the reliable functioning of any firearm.

LUBRICATION WARNING

Firing a shotgun with oil, grease or other material even partially obstructing the bore may result in damage to the gun and injury to the shooter and those nearby. Before firing shotgun be certain that the bore and chamber of each barrel is unobstructed and dry.

Do not spray or apply lubricants on shotshells. If the shotshell powder charge is affected by a lubricant, it may not ignite, but the energy from a fired primer may push the shot charge into the bore where it becomes an obstruction. Firing another shotshell behind such an obstruction may damage the gun and injure the shooter and those nearby. Use lubricants properly and sparingly. You are responsible for the proper care and maintenance of your shotgun.

SERVICE AND PARTS POLICY

Before shipment, every Ruger firearm is inspected and test-fired to ensure that it conforms fully to our specifications and standards. If you have any questions with regard to the performance of your Ruger Over and Under Shotgun, please write to our Product Service Department fully describing all circumstances and conditions involved.

If you should return your gun to the factory for repair, or order parts for it, please comply with the following suggestions for prompt service:

SHIPPING FIREARMS FOR REPAIR:

(1) Ruger Over and Under Shotguns returned to the factory for service or repair should be sent to:

Sturm, Ruger & Company, Inc.
Product Service Department
411 Sunapee Street
Newport, New Hampshire 03773
(603) 863-3300

(2) Guns shipped to the factory should be sent prepaid. *We will not accept collect shipments.*

(3) The Federal Gun Control Act, as well as the laws of most States and localities, does not prohibit an individual (who is not otherwise barred from purchasing or possessing a firearm) from shipping a firearm directly to the manufacturer for repair. However, before you ship your shotgun to us, be certain that your State or locality does not have a law or regulation which will prohibit you from receiving the firearm from us after it has been repaired. If such receiving is prohibited then please have a Federally Licensed firearms dealer ship the gun to us. It will be returned to him after being repaired.

Shotguns and rifles may be shipped via Parcel Post or via UPS. Always insure the shipment. (An individual may *not* ship a handgun via U.S. Mail.)

(4) **WARNING: Before shipping any firearm, be absolutely certain that it is unloaded.**

(5) Enclose a letter which includes your name, address, telephone number, and serial number and model of the firearm. Describe in detail the trouble you have experienced with your firearm, or the work you wish to have done. Merely stating that the firearm 'needs repair' is inadequate information. Please enclose copies of any previous correspondence.

(6) Work performed will bear a net *minimum* labor charge of \$15.00 plus \$5.00 for shipping and handling. The charge for rebluing is \$50.00, or \$25.00 for barrels *only*, plus \$5.00 shipping and handling.

(7) The charge for converting the automatic safety of the Ruger Over and Under Shotgun to a *non-automatic* safety which must be engaged manually is \$12.00 which includes labor plus \$5.00 shipping and handling. Please ship your gun to the factory for this conversion.

(8) Please do not ship your carrying case, scabbard, or any custom accessories with any gun being shipped to the factory for service or repair.

ORDERING PARTS:

All parts orders for the **RUGER OVER AND UNDER SHOTGUN** should be sent to Sturm, Ruger & Co., Inc., Service Department, 411 Sunapee Street, Newport, New Hampshire, 03773, 603-863-3300. We cannot comply with open account or C.O.D. orders. Payment in the form of a check, money order, Visa or Mastercard must accompany your order. Credit Card orders must include the account number, expiration date and whether it is a Visa or Mastercard account. Minimum parts order is \$1.00 plus \$3.50 shipping and handling charge. Order parts by Part Name and Part Number and include the entire serial number of the firearm for which the parts are being ordered. The price shown for parts does not include the minimum net labor charge of \$15.00 plus \$5.00 shipping and handling charge. All factory fitted parts are fit on an exchange basis only. We will not return the replaced parts.

Barrels and a number of other component parts must be fitted at the factory. Company policy is to proof-test and/or function fire all barrels after fitting to the receivers in which they are to be used. This procedure ensures maximum protection to our customers. The special proof-test ammunition used in this testing is sold only to bonafide firearms manufacturers and is not available to gun shops, gunsmiths, or individuals.

The receiver of the **RUGER OVER AND UNDER SHOTGUN** is defined as a "firearm" by Federal Law and is not offered for sale as a component part.

Parts designated by an asterisk (*) must be factory fitted. These parts are fitted on an exchange basis only. We will not return the replaced parts. We will not return any part that is broken, malfunctioning, badly worn or has been modified. See "Warning — Parts Purchasers" below.

WARNING TO PARTS PURCHASERS

It is the purchaser's responsibility to be absolutely certain that any parts ordered from the factory are correctly fitted and installed. Firearms are complicated mechanisms and IMPROPER FITTING OF PARTS MAY RESULT IN A DANGEROUS MALFUNCTION, DAMAGE TO THE FIREARM, AND INJURY TO THE SHOOTER AND OTHER PERSONS. The purchaser and installer of parts must accept full responsibility for the correct adjustment and functioning of the shotgun after such installation.

WARNING: Firearms users are cautioned that a gun containing modified, broken, malfunctioning or badly worn parts should *not be fired!*

NOTE: Parts with a "K" prefix are available in Stainless Steel Only.

PARTS LIST AND SUGGESTED RETAIL PRICES

Design, prices and specifications subject to change without notice.

SPECIFY MODEL WHEN ORDERING

12 & 20 Gauge Shotgun

(see Exploded Views on Pages 16 & 17)

Part Name	Part No.	Price
* Barrel Assembly — 12 & 20 ga.	† OU003XX	\$500.00
* Barrel Assembly — 12 ga. Sporting Clays	† OU50002	738.75
* Barrel Assembly — 26" bbl. — 12 ga. Non-Choke Model	† OU-3-AS-12A	426.25
* Barrel Assembly — 28" bbl. — 12 ga. Non-Choke Model	† OU-3-AS-12B	426.25
* Barrel Assembly — 26" bbl. — 20 ga. Non-Choke Model	† OU-3-AS-A	426.25
* Barrel Assembly — 28" bbl. — 20 ga. Non-Choke Model	† OU-3-AS-B	426.25
Barrel Filler Strip, 26" bbl. (2 req'd)	OU02201	4.75
Barrel Filler Strip, 28" bbl. (2 req'd)	OU02202	4.75
* Blocking Bar	KOU-49	2.75
Blocking Bar Retaining Pin	OU-36	1.25
Center Sight — 12 ga. Sporting Clays	OU06701	0.50
Choke Insert, Full (3 slots) — 12 ga.	OU08900	24.95
Choke Insert, Modified (2 slots) — 12 ga.	OU08901	24.95
Choke Insert, Improved (1 slot) — 12 ga.	OU08902	24.95
Choke Insert, Skeet (no slots) — 12 ga.	OU08903	24.95
Choke Insert, X Full (4 slots) — 12 ga.	OU08904	24.95
Choke Insert, Full (3 slots) — 20 ga.	OU08905	24.95
Choke Insert, Modified (2 slots) — 20 ga.	OU08906	24.95
Choke Insert, Improved (1 slot) — 20 ga.	OU08907	24.95
Choke Insert, Skeet (no slots) — 20 ga.	OU08908	24.95
Choke Insert, Full 12 ga. Sporting Clays	KOU08910	24.95
Choke Insert, Modified 12 ga. Sporting Clays	KOU08911	24.95
Choke Insert, Improved 12 ga. Sporting Clays	KOU08912	24.95
Choke Insert, Skeet 12 ga. Sporting Clays	KOU08913	24.95
Choke Insert, X Full 12 ga. Sporting Clays	KOU08909	24.95
Choke Insert Key — 12 & 20 ga. All Models	OU09001	3.00
Cocking Cam, Left	KOU-15L	3.50
Cocking Cam, Right	KOU-15R	3.50
Cocking Cam Pivot Pin	OU-34	0.50
Cocking Cam Sleeve (2 req'd)	OU-45	ea. 0.50
Cocking Cam Spring (2 req'd)	OU-44	ea. 0.50
Cocking Rod (2 req'd)	OU-14	ea. 2.75
Ejector Plunger (2 req'd)	OU-29	ea. 1.25
Ejector Sear Plunger (2 req'd)	OU-46	ea. 0.50
Ejector Sear Plunger Spring (2 req'd)	OU-47	ea. 0.50
* Ejector Sear, Left, 12 ga.	OU-13L-12	8.00
* Ejector Sear, Right, 12 ga.	OU-13R-12	8.00
* Ejector Sear, Left, 20 ga.	OU-13L-20	8.00
* Ejector Sear, Right, 20 ga.	OU-13R-20	8.00
Ejector Spring (2 req'd)	OU-30	ea. 0.50
Ejector Spring Guide (2 req'd)	OU-30A	ea. 0.50

† We cannot fit a screw-in choke barrel assembly to guns with fixed chokes nor fit a fixed choke barrel assembly to guns with screw-in chokes.

Part Name	Part No.	Price
* Ejector, Left, 12 ga.	OU-8L-12	\$25.25
* Ejector, Right, 12 ga.	OU-8R-12	25.25
* Ejector, Left, 20 ga.	OU-8L-20	25.25
* Ejector, Right, 20 ga.	OU-8R-20	25.25
* Firing Pin, Top, 12 & 20 ga.	OU-11-12	4.75
* Firing Pin, Bottom (Not Illustrated)	OU-11-20	4.75
Firing Pin Retaining Pin (2 req'd)	OU-51	ea. 0.50
Firing Pin Spring (2 req'd)	OU-12	ea. 0.50
* Forearm, American Walnut, 12 ga.	OU00502	86.25
* Forearm, American Walnut, 20 ga.	OU00503	86.75
Forend Escutcheon Medallion (Brass) (2 req'd)	S-61	ea. 0.50
Forend Filler Block, Left, 12 ga.	OU-78L-12	2.50
Forend Filler Block, Right, 12 ga.	OU-78R-12	2.50
Forend Filler Block, Left, 20 ga.	OU-78L-20	2.50
Forend Filler Block, Right, 20 ga.	OU-78R-20	2.50
Forend Filler Screw (4 req'd)	OU-81-20	ea. 0.50
Forend Iron Escutcheon	OU-27	0.50
Forend Iron Escutcheon Screw	OU-48	0.50
* Forend Iron Sub-Assembly, 12 ga.	KOU-79-12	70.25
* Forend Iron Sub-Assembly, 20 ga.	KOU-79-20	66.00
Forend Latch Lever	KOU-28	2.00
Forend Latch Lever Pin	OU-40	0.50
Forend Latch Plunger	OU-74	0.50
Forend Latch Spring	OU-41	0.50
Front Sight	OU-67	0.50
* Hammer, Left	KOU-17L	8.50
* Hammer, Right	KOU-17R	8.50
* Hammer Interrupter	KOU-75	6.25
Hammer Pivot Pin	OU-43	0.50
Hammer Spring (2 req'd)	OU-18	ea. 0.50
Hammer Strut Assembly	KOU-25BL	5.00
Hammer Strut Assembly	KOU-25BR	5.00
Inertia Weight	KOU-53	5.25
Inertia Weight Spring	OU-58	0.75
* Interrupter Plunger	OU-85	0.75
* Interrupter Plunger Spring	OU-83	0.50
Link	OU-64	0.50
* Locking Bolt	KOU-9	11.75
Pistol Grip Cap	S-97	7.00
Pistol Grip Cap Medallion	OU-57	0.75
Pistol Grip Cap Screw	S-36	0.50
Receiver — 12 ga.	KOU-1-12	Not Offered For Sale
Receiver — 20 ga.	KOU-1-20	Not Offered For Sale
Recoil Pad, Rubber	D06301	5.00
Recoil Pad Screw	D-84	ea. 0.50
Safety Block	KOU-52	5.50
Safety Detent Plunger (2 req'd)	OU-39	ea. 0.50
Safety Detent Spring (2 req'd)	OU-54	ea. 0.50
Safety Thumbpiece	OU-32	5.50
Safety Thumbpiece Detent	OU-68	0.50
Safety Thumbpiece Detent Spring	OU-69	0.50
* Sear, Left	KOU02302	7.00
* Sear, Right	KOU02304	7.00
* Sear Selector	KOU-16	7.50

<u>Part Name</u>	<u>Part No.</u>		<u>Price</u>
Sear Selector Link Pivot Pin & Sear Selector Actuator Retaining Pin (2 req'd)	KE-55	ea.	\$0.50
Sear Selector Pivot Pin	OU-66		0.50
* Sear Spring	OU-42		0.50
Stock Bolt	S-37		0.75
Stock Bolt Washer	S-38		0.50
* Stock, American Walnut, Pistol Grip, 12 ga.	OU00408		159.25
* Stock, American Walnut, Pistol Grip, 20 ga.	OU00409		159.25
Stock, American Walnut, Straight, 12 ga.	OU00402		159.25
Stock, American Walnut, Straight, 20 ga.	OU00403		159.25
Stock, American Walnut - 12 ga. Sporting Clays	OU00406		177.50
* Top Lever, 12 ga.	OU-6-12		11.00
* Top Lever, 20 ga.	OU-6-20		11.75
Top Lever Spring	OU-56		0.50
Top Lever Spring Strut	OU-55		1.00
Top Lever Trip — 12 ga.	OU-71-12		0.75
Top Lever Trip — 20 ga.	OU-71-20		0.75
Top Lever Trip Plunger	OU-72		0.50
Top Lever Trip Plunger Spring	OU-73		0.50
Trigger	KOU-20		7.75
Trigger & Sear Pivot Pin (2 req'd)	OU-21	ea.	0.50
Trigger Guard	OU-2		22.00
Trigger Guard Retaining Pin, Trigger Stop Pin, Link Retaining Pin, Inertia Weight Pivot Pin	S-31	ea.	0.50

* Parts so marked must be factory fitted.

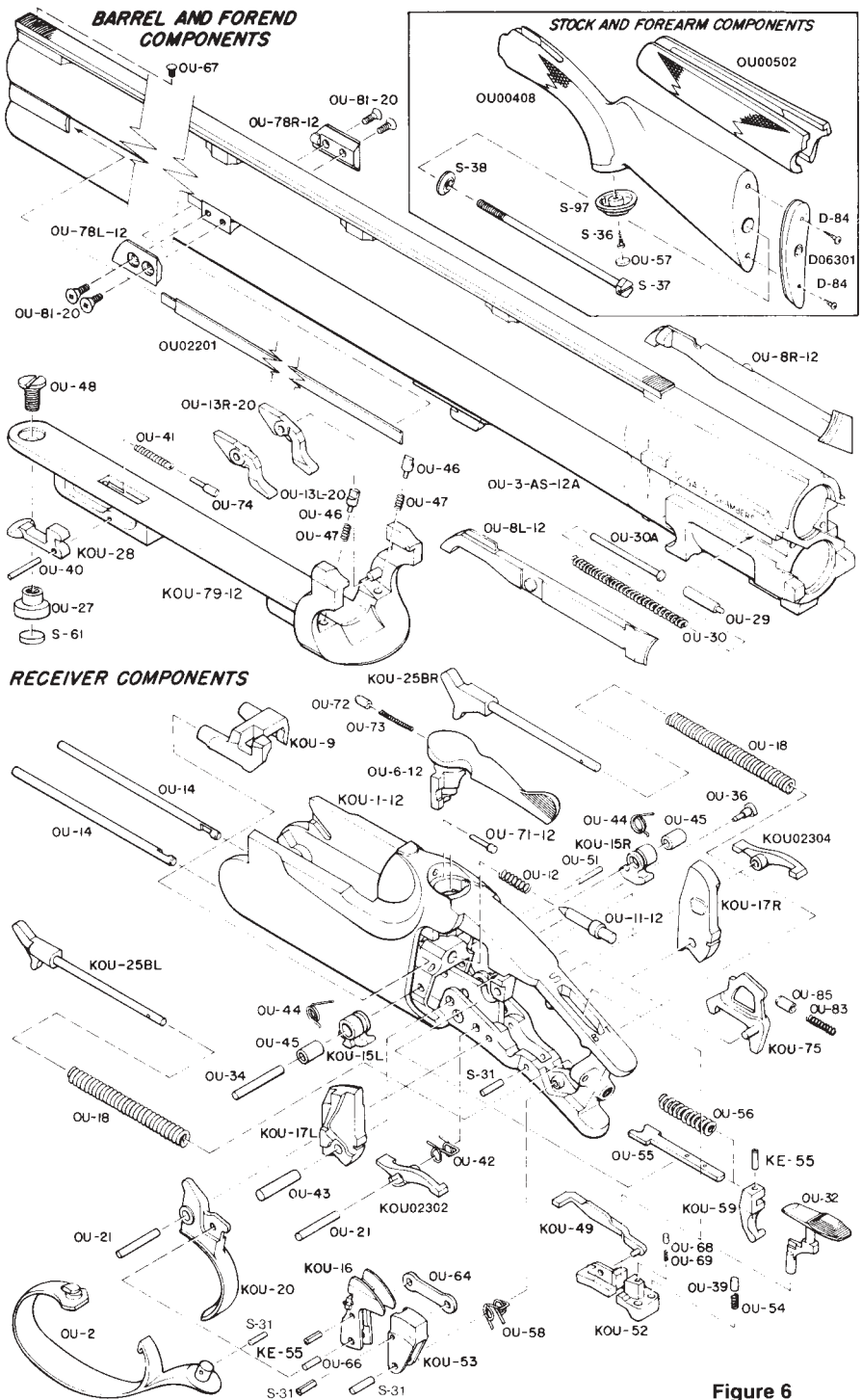

**Figure 6
COMPONENT PARTS
FOR 12 GAUGE**

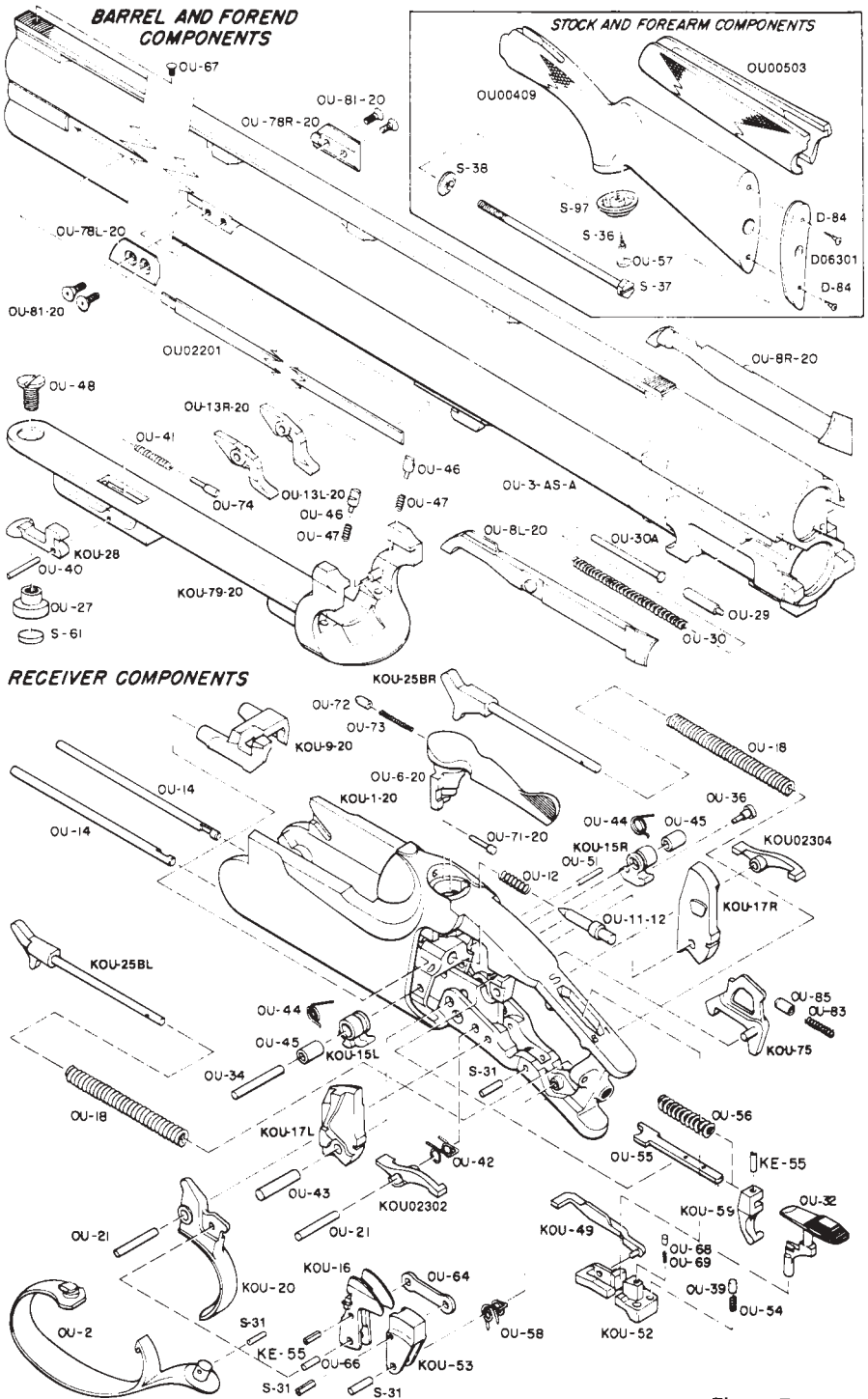
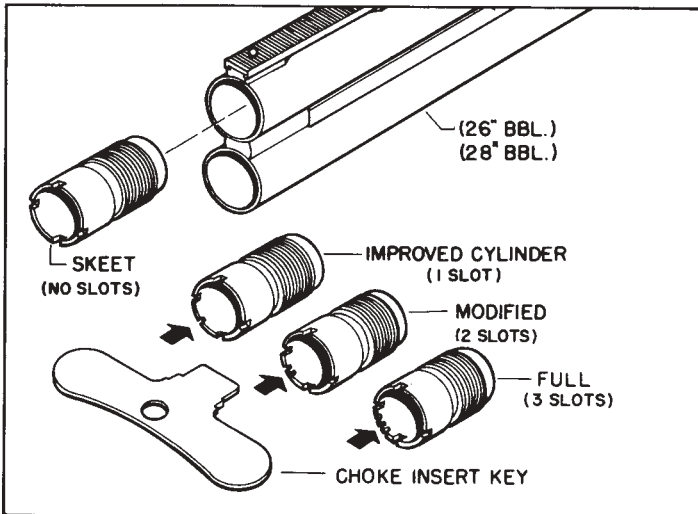

**Figure 7
COMPONENT PARTS
FOR 20 GAUGE**

SCREW-IN CHOKE INSERTS ORDERING INFORMATION

Ruger shotguns equipped with screw in choke inserts have a slightly different barrel configuration than fixed-choke barrels. Due to dimensional variations, screw-in choke inserts *cannot* be retrofitted into existing barrels (part numbers OU-3AS-12-A, OU-3AS-12-B, OU-3-AS-A & OU-3-AS-B). All barrels equipped with screw-in choke inserts have 3" chambers. Choke inserts are marked with the following identification slots on the front edge of the inserts:

Extra choke inserts are available for \$24.95 each. Please specify degree of choke desired and use the appropriate part number found in the Parts List.



THE BASIC RULES OF SAFE FIREARMS HANDLING

We believe that Americans have a right to purchase and use firearms for lawful purposes. The private ownership of firearms in America is traditional, but that ownership imposes the *responsibility* on the gun owner to use his firearms in a way which will ensure his own safety and that of others. When firearms are used in a safe and responsible manner, they are a great source of pleasure and satisfaction, and represent a fundamental part of our personal liberty.

Firearms do not cause accidents! Firearms accidents are almost always found to have been the result of carelessness, or ignorance on the part of the shooter of the basic rules of safe gun handling.

The following rules must be observed by gun users at all times. Safe gun handling is not just desirable, it is absolutely essential to the continuation of gun ownership and sport shooting as we know it today.

1. LEARN THE MECHANICAL AND HANDLING CHARACTERISTICS OF THE FIREARM YOU ARE USING. Not all firearms are the same. The method of carrying and handling firearms varies in accordance with the mechanical provisions for avoiding accidental discharge and the various proper procedures for loading and unloading. No person should handle any firearm without *first* having thoroughly familiarized himself with the particular type of firearm he is using, and with safe gun handling in general.

2. ALWAYS KEEP THE MUZZLE POINTED IN A SAFE DIRECTION. Be sure of the bullet stop behind your target, even when dry-firing. Never let the muzzle of a firearm point at any part of your body or at another person. This is particularly important when loading or unloading a firearm. In the event of an accidental discharge, no injury can occur as long as the muzzle is pointing in a safe direction. A safe direction means a direction which will not permit a discharged bullet to strike a person, or to strike an object from which the bullet may ricochet. A safe direction must take into account the fact that a bullet may penetrate a wall, ceiling, floor, window, etc., and strike a person or damage property. Make it a habit to know exactly where the muzzle of your gun is pointing whenever you handle it, and be sure that you are always in control of the direction in which the muzzle is pointing, even if you fall or stumble.

3. FIREARMS SHOULD BE UNLOADED WHEN NOT IN USE. Firearms should be loaded only when you are in the field or on the target range or shooting area, ready to shoot. Firearms and ammunition should be securely locked in racks or cabinets when not in use. Ammunition should be safely stored *separate* from firearms. Store your firearms out of sight of visitors and children. It is the gun owner's *responsibility* to be certain that children and persons unfamiliar with firearms cannot gain access to firearms or ammunition.

4. BE SURE THE BARREL IS CLEAR OF OBSTRUCTIONS BEFORE SHOOTING. Even a bit of mud, snow, or excess lubricating oil or grease in the bore may cause the barrel to bulge, or even burst on firing, and can cause injury to the shooter and bystanders. Be sure that you are using ammunition of the proper caliber and loading for the gun you are using. If the report or recoil on firing seems weak, or doesn't seem quite right, **CEASE FIRING IMMEDIATELY** and check to be sure that no obstruction has become lodged in the barrel.

5. BE SURE OF YOUR TARGET BEFORE YOU SHOOT. Don't shoot unless you know exactly where your bullet is going to strike. Be sure of the bullet stop behind your target, even when dry-firing with an unloaded gun. If you are in the field hunting, do *not* fire at a movement or noise. Take the time to be *absolutely certain* of your target before you pull the trigger.

6. WEAR SHOOTING GLASSES AND HEARING PROTECTORS WHEN YOU SHOOT. All shooters should wear protective shooting glasses and some form of hearing protectors when shooting. Exposure to shooting noise can damage hearing, and adequate vision protection when shooting is essential.

7. NEVER CLIMB A TREE OR FENCE WITH A LOADED FIREARM. Put the firearm down carefully before climbing a fence, and *unload* it before climbing or descending a tree or jumping over a ditch or other obstruction. Never pull or push a loaded firearm toward yourself or another person. When in doubt, unload your gun!

8. DON'T SHOOT AT A HARD SURFACE, OR AT WATER. Bullets can glance off many surfaces like rocks or the surface of water and travel in unpredictable directions with considerable velocity.

9. NEVER TRANSPORT A LOADED FIREARM. Firearms should always be unloaded before being placed in a vehicle. A suitable carrying case or scabbard should be used to carry an unloaded firearm to and from the shooting area.

10. AVOID ALCOHOLIC BEVERAGES WHEN SHOOTING. Don't drink until the day's shooting is over. Handling firearms while under the influence of alcohol in any form constitutes a criminal disregard for the safety of others.

CAUTION

The Ruger Over and Under shotgun should not be disassembled by persons not qualified in shotgun repair.

If the stock, parts OU-4-12 & OU-4-20, is removed from the firearm, upon reassembly, it must be retorqued to a maximum of 4ft/lbs. Excessive tightening of the stock retaining screw, part S-37, may result in the stock cracking.



WHY NO WARRANTY CARD HAS BEEN PACKED WITH THIS NEW RUGER FIREARM

The Magnuson-Moss Act (Public Law 93-637) does not require any seller or manufacturer of a consumer product to give a written warranty. It does provide that if a written warranty is given, it must be designated as "limited" or as "full" and sets minimum standards for a "full" warranty.

Sturm, Ruger & Company, Inc. has elected not to provide any written warranty either "limited" or "full", rather than to attempt to comply with the provisions of the Magnuson-Moss Act and the regulations issued thereunder.

There are certain implied warranties under state law with respect to sales of consumer goods. As the extent and interpretation of these implied warranties varies from state to state, you should refer to your state statutes.

Sturm, Ruger & Company wishes to assure its customers of its continued interest in providing service to owners of Ruger firearms.

**A COPY OF THE INSTRUCTION MANUAL FOR EACH MODEL RUGER FIREARM
IS AVAILABLE FROM THE FACTORY ON REQUEST.
THESE INSTRUCTION MANUALS CONTAIN IMPORTANT WARNINGS
WHICH MUST BE UNDERSTOOD BEFORE USING THESE FIREARMS.**