



OWNERS MANUAL

FOR MODELS
500[®], 835[®] AND 590[®]
PUMP ACTION SHOTGUN

IMPORTANT "SAFETY WARNINGS" - NOTE THE SYMBOL



These safety warnings are for your protection as well as the safety of others. Disregarding information in this manual may result in serious injury or death.



Be certain this owners manual is available for reference and is kept with this firearm if transferred to another party. If manual is lost or misplaced, write directly to Mossberg for a free replacement copy.



After performing any work on your firearm such as cleaning, adjustments, disassembly or installation of any accessory, the gun should be re-checked for proper functioning before firing live ammunition.



Firearms are complicated mechanisms. Any modification, alteration, or improper fitting of parts may result in a dangerous malfunction, damage to the firearm and injury to the shooter and other persons. The gun owner must accept full responsibility for the correct reassembly and functioning of the firearm after any disassembly or replacement of parts.



If you do not understand any of the material in this manual or have any questions, contact a qualified gunsmith or write to: O.F. Mossberg & Sons, Inc., directly.



Do not attempt to load or use any firearm until you read and understand the information contained in its owner's manual. Before handling your firearm, you should learn how it operates and how to maintain it. This includes knowing its basic parts, how the manual safety and other safety features operate, how to safely open and close the action and how to safely load and unload ammunition from the gun. Improper use and handling is dangerous and could cause severe injury or death to you or those around you. All users of the firearm must become thoroughly familiar with the instructions in this manual.

O.F. MOSSBERG & SONS, INC.

P.O. BOX 497 • 7 GRASSO AVENUE, NORTH HAVEN, CONNECTICUT 06473

PHONE (203) 230-5300 FAX (203) 230-5420

www.mossberg.com

Safety and safe firearms handling is everyone's responsibility.



As the owner of a firearm, you must undertake the full-time responsibility of safe firearms handling for your own safety and the safety of those around you:

- Keep all firearms and ammunition out of the reach of children.
- Store your firearms and ammunition separately.
- Never store a loaded firearm.
- Never leave a loaded firearm unattended.
- Never transport a loaded firearm in a vehicle.



Always point the muzzle of your firearm in a safe direction, regardless of whether the firearm is loaded or unloaded. You should become thoroughly familiar with the function and operation of this firearm and the instructions supplied with it.



Always treat every firearm as if it were loaded. Give your firearm to someone with the action open (bolt fully rearward) and safety fully rearward in the "ON" (SAFE) position after you verify the firearm is unloaded. Insist on the same procedure when receiving a firearm from someone else. Learn the location of all the safety features of your firearm and how they operate.



Wear eye and ear protection when shooting. Shooting without proper ear protection can cause hearing damage. The use of eye protection during any type of shooting is important to protect your vision.



Due to the heavy recoil of a shotgun, maintain an adequate distance between the rear of the scope and your face at all times. Be certain the scope installation does not interfere with access to, or the proper functioning of the safety button.



We specifically disclaim any responsibility for damage or injury whatsoever occurring in connection with, or as a result of, the use of faulty, or non-SAAMI standard, or "remanufactured" or hand-loaded (reloaded) ammunition. Additionally, we disclaim any responsibility for damage or injury which results from any modifications or changes that are not a part of the firearm as delivered from the factory.



Learn to clean your firearm thoroughly and make certain no oil, grease or other materials are blocking the barrel. Obstructions of any kind can cause damage to the firearm resulting in personal injury.

Practice proper firearm maintenance and safety. Make sure all exposed metal surfaces are coated with a thin film of oil, especially after being exposed to damp weather. (See proper section of this manual for cleaning instructions). Do not plug barrel or store in a fabric-lined case which will absorb lubricants from the firearms. Before using after storage, follow complete instructions stated in this manual for familiarization with the firearm. A thorough inspection should be performed before going into the field. Have your gun periodically checked by a qualified gunsmith.

OPERATING INSTRUCTIONS

Read and understand this entire manual and its safety warnings before firing the shotgun.



Remember, a firearm's manual safety is a mechanical device which can never replace safe gun handling practices.

MECHANICAL SAFETY

The safety is located on the top rear portion of the receiver (Fig. 2) and must be manually moved to the desired position by the shooter.

To put the safety in the "ON" (SAFE) position, the safety button must be moved fully rearward into the safety detent. The button will now be over the red dot. The red dot is a training aid used only to show the direction of the "ON" (SAFE) position and should not be used as an indicator that the safety is "on" or "off" (Fig. 2). Moving the safety button forward toward the muzzle of the gun will put the safety in the "OFF" (FIRE) position.

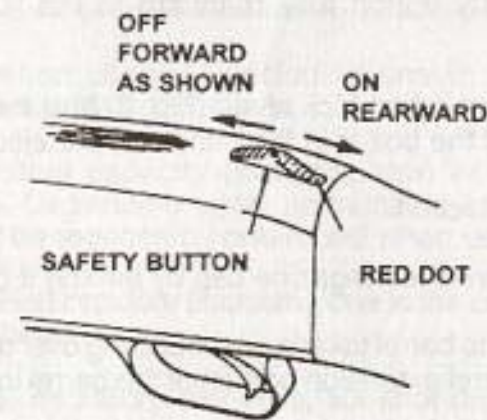

Fig. 2

ACTION RELEASE CONTROL

The action lock lever is located on the left side of the trigger housing just rearward of the triggerguard.

The action lock lever allows the action to be unlocked and opened for inspection or unloading without pulling the trigger. The action may be opened by depressing the lever and pulling the forearm rearward (Fig. 3).

NOTE: During firing, the action unlocks automatically after the hammer falls and the action can be cycled without depressing the action lock lever.



Fig. 3

BARREL ASSEMBLY

! Barrels are **not** interchangeable between model numbers, gauge or capacity. 500, 835 and 590 barrels are interchangeable **only** with barrels of the same model, gauge and capacity.

CAUTION: Never close the action or pull trigger while barrel is removed as damage could result to the firearm.

To facilitate shipping, some models are packaged with the barrel removed. To install the barrel in the receiver, proceed as follows:

! Visually inspect the inside of the barrel to make certain it is free of any obstructions, excessive oil or grease before installation. If you are unable to remove all obstructions, bring the gun to a qualified gunsmith or ship it to the Mossberg Service Center. Failure to do so may result in gun damage and/or personal injury if the shotgun is fired.

! Move the safety button fully rearward to the "ON" (SAFE) position (Fig. 2).

All Models: Depress the action lock lever, (Fig. 3) and move the forearm rearward until the front of the bolt is in the middle of the ejection port (Fig. 7).

Caution: Wear eye protection.

Model 590/835: Unscrew the magazine cap by turning it counterclockwise.

Slide the barrel takedown mount ring over the magazine tube while guiding the barrel extension portion of the barrel into the receiver (Fig. 4).

Gently rotate the barrel back and forth while pushing the barrel into the receiver.

Slide the barrel into the receiver and tighten the magazine cap, finger tight only. **DO NOT** use pliers or a wrench to tighten the magazine cap.

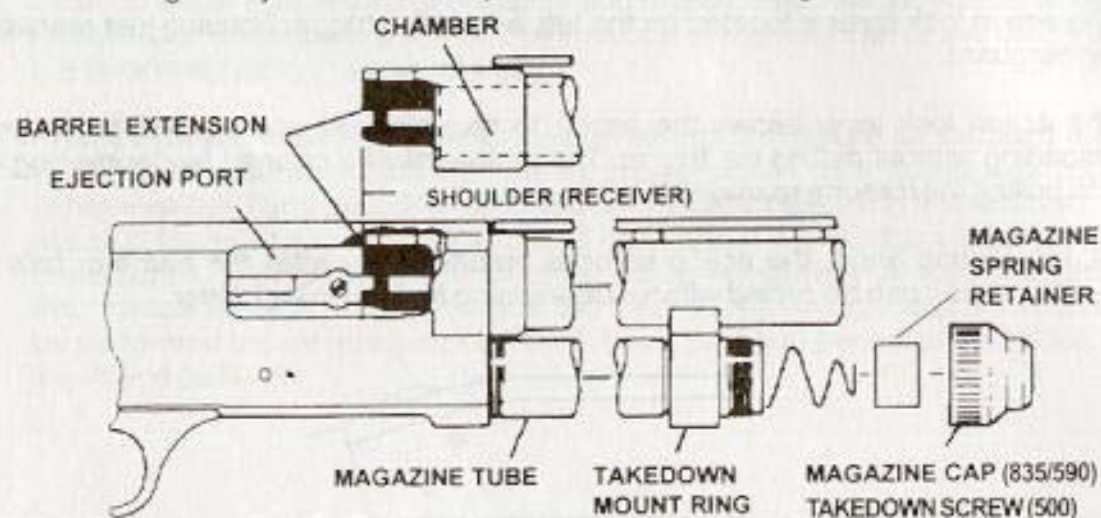

Fig. 4

If your 590/835 shotgun is equipped with a magazine spring retainer, prior to putting on the magazine cap, assemble the magazine spring retainer over the protruding magazine spring. Push the retainer downward inside magazine tube so that the spring retainer is flush with the magazine tube end.

Caution: The magazine spring exerts pressure on the retainer use caution when disassembling.

To disassemble: Pry up at various points around the small hole in the center of the magazine spring retainer. Cup hand over retainer and magazine so as to keep spring and retainer confined. Use caution not to bend or distort the magazine tube end and or threads.

Model 500: Slide the barrel into the receiver and tighten the takedown screw, finger tight only. **DO NOT** use pliers or a wrench to tighten the takedown screw. A little space between the magazine tube and the takedown mount is normal.

! **WARNING: (all models):** Check to be certain that the barrel is fully seated into the receiver by looking through the ejection port. The barrel extension must rest firmly against the corresponding cut in the top of the receiver as shown in Figure 4.

MAGAZINE CAPACITY

Model 835: Total ammunition capacity (including one in the chamber) is six (6) 2-3/4" or 3" or five (5) 3-1/2" shells.

Model 500: Total ammunition capacity (including one in the chamber) is six (6) 2 3/4" shells. Depending upon ammunition tolerance variations, total capacity may be reduced by one round when using 3" shells.

Model 590: Total ammunition capacity (including one in the chamber) is nine (9) 2-3/4" or six (6) 3" shells.

NOTE: To comply with U.S. migratory bird laws, six shot models are shipped with a wooden dowel inserted in the magazine tube which limits magazine capacity to two (2) shells.

Model 835: To remove the dowel, first remove the barrel. Point the gun downward and shake it back and forth lightly until the dowel falls out.

To change back to a 2 shot magazine capacity insert the dowel through the center of the magazine spring so that it is positioned inside the coils of the spring.

Model 500 Bantam: This Model is supplied as a single shot. An extra long wooden dowel blocks magazine loading. After proper firearm training the dowel can be cut to 9" to comply with appropriate laws.

Model 500: To remove the dowel, first remove the barrel. Point gun downward and shake it back and forth lightly until the dowel protrudes from the takedown screw hole in the end of the magazine tube. A rubber "O" ring on the dowel prevents it from falling out accidentally. Grasp the dowel and pull it completely out.

LOADING

! Before loading, move the safety button fully rearward (Fig. 2) to the "ON" (SAFE) position.

! During loading never allow fingers or any objects to contact the trigger. Keep the muzzle pointed in a safe direction at all times.

! Depress the action lock lever (Fig. 3) and open the action by pulling the forearm completely rearward.

 Inspect the chamber and bore of the barrel for any obstruction, excessive oil or grease. The chamber is the rear portion of the barrel which contains the cartridge (Fig. 4). Failure to do so may result in gun damage and/or personal injury when the shotgun is fired.

 Do not load shotgun until ready for use! Unload shotgun when shooting has been completed! The safety button should always be fully rearward in the "ON" (SAFE) position whether the firearm is loaded or not.

 Check to be certain that the ammunition selected is the same type of cartridge as designated on the left side of the barrel.

The **Model 835** is designed to fire 12 gauge 2-3/4", 3" or 3-1/2" factory loaded ammunition. Do not fire slugs of any type (single projectile ammunition) through the overbored **Model 835** Accu-Mag barrel. This barrel is designed to shoot lead or steel pellet shot loads only. Use only **Model 835** barrels designed specifically for slug shooting.

Model 590's handle 12 ga. 2-3/4" or 3" magnum shells. **Model 500's** are designed for 2-3/4" (2-1/2" .410 bore) and 3" magnum shells within gauge.

Fully rifled barrels deliver best accuracy with sabot style slugs. "Rifled" slugs and shotshells are not recommended for use in rifled barrels.

If you wish to load the firearm with the maximum number of shells, or fire single shots, load the first shell through the ejection port located on the right side of the receiver (Fig. 5). The shell can be inserted directly into the chamber or placed on top of the elevator. Close the action by moving the forearm completely forward. Be sure to leave the safety "ON" (fully rearward) until you are ready to shoot.

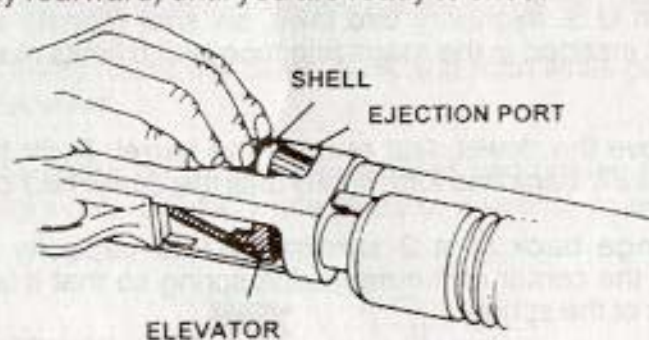



Fig. 5 — Loading through the ejection port

 **THE SHOTGUN IS NOW LOADED!** The safety button should be fully rearward in the "ON" (SAFE) position until ready for use. Keep the muzzle pointed in a safe direction at all times.

LOADING MAGAZINE

Load the magazine tube by turning the shotgun so that the trigger guard is facing up and the action is closed. Push the front end of the shell into the magazine tube until the rim of the shell snaps past the cartridge stop (Fig. 6 & 9). Never attempt to exceed the magazine capacity.

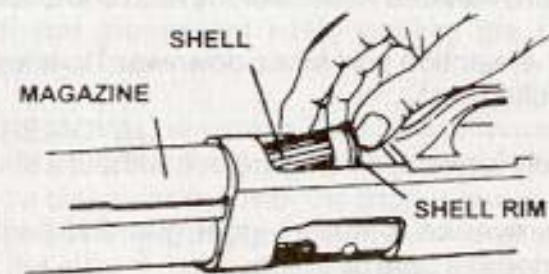





Fig. 6

FIRING

 Discharging firearms in poorly ventilated areas, cleaning firearms, or handling ammunition may result in exposure to lead and other substances known to cause birth defects, reproductive harm, and other serious physical injury. Have adequate ventilation at all times. Wash hands thoroughly after exposure.

With the shotgun pointed in a safe direction and held in the proper firing position, move the safety forward to its "OFF" (FIRE) position. Pulling the trigger through its full travel to the rear, will fire the shotgun.

 Should the round fail to fire, keep the gun pointed in a safe direction. Move the safety button fully rearward to the "ON" (SAFE) position. Remove the misfired round and segregate from other ammunition. Do not attempt to re-fire a misfired round.

 If at any time during firing, the report of any given round is noticeably louder or softer than previous rounds fired, STOP! Do not load or fire additional rounds until you have put safety in the "ON" (SAFE) position, then safely unload your firearm and inspect it for possible damage or obstruction in the chamber or bore.

CYCLING THE ACTION

To eject a shotshell case, pull the forearm completely rearward. The spent case or unfired shotshell will eject out of the receiver through the ejection port.

 Be sure that all observers are clear of the path of ejection. Empty cases are thrown out with significant force and could cause injury.

To chamber a live shotshell from the magazine, push the forearm fully forward.

 Remember: when the magazine tube is loaded and the action is cycled, a live shotshell will be chambered! Always keep the safety in the "ON" (SAFE) position until you are actually ready to fire the shotgun.

UNLOADING

 Move the safety button fully rearward (Fig. 2) to the "ON" (SAFE) position. During unloading, never allow fingers or any object to contact the trigger. Keep the muzzle pointed in a safe direction at all times.

Depress the action lock lever (Fig. 3) and pull the forearm rearward, slowly, until the live shotshell is completely withdrawn and visible in the ejection port. Remove shotshell by hand.

Continue pulling the forearm rearward to release the next shotshell onto the elevator.

Turn the shotgun so that the ejection port faces downward to allow the released shotshell to drop out through the ejection port.

Push the forearm completely forward, closing the bolt without a shell being chambered.

 Turn the shotgun over so that the trigger guard is positioned upward and the gun remains pointed in a safe direction.

Insert your right thumb into the opening in the bottom of the receiver and depress the cartridge stop on the right side to release shotshells one at a time (Fig. 9). Repeat until all shotshells are removed from the magazine tube.

 Depress the action lock lever and pull the forearm completely rearward. Visually inspect chamber, elevator and magazine tube again to insure that no shotshells remain in the shotgun.

Leave the action in the open, rearward position and the safety button fully rearward in the "ON" (SAFE) position.

DISASSEMBLY / BARREL REMOVAL

 Position the safety button fully rearward in the "ON" (SAFE) position and check chamber, elevator and magazine to be certain gun is unloaded. Wear eye protection during disassembly and cleaning.

Depress the action lock lever (Fig. 3) and open the action by sliding the forearm fully rearward.

Move the forearm slowly forward from the fully rearward position until the front of the bolt is in the middle of the ejection port (Fig. 7).

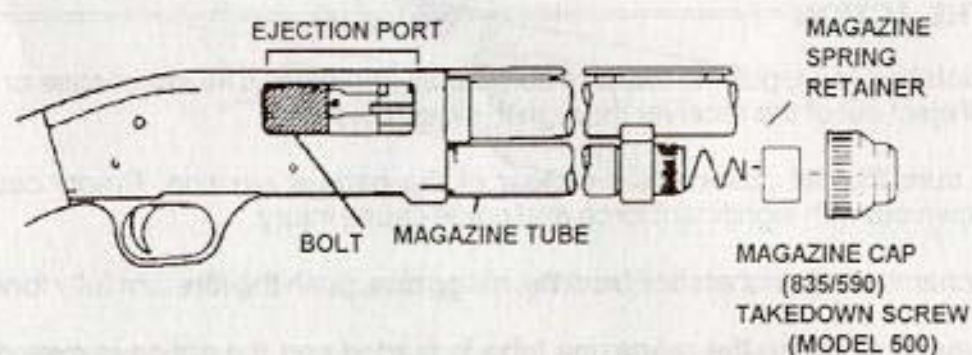

Fig. 7 — Removal of barrel

CAUTION: The Model 590 and 835 magazine spring retainers and springs are under significant spring pressure. Use caution should removal be necessary to prevent injury to yourself or others around you.

Model 835/590: Unscrew the magazine cap by turning it counterclockwise.

Remove the barrel from the receiver with a gentle back-and-forth rotational movement while pulling the barrel out of the receiver assembly.

Model 500: Loosen the takedown screw by turning it counterclockwise until the screw threads are completely disengaged from the end of the magazine tube (Fig. 7.)

Remove the barrel from the receiver with a gentle back-and-forth rotational movement while pulling the barrel out of the receiver assembly.

TRIGGER HOUSING REMOVAL

Position the shotgun on a clean surface with the trigger guard upward. With a blunt object (no greater than 3/16" [4.76 mm] diameter), push out the small diameter trigger housing retainer pin located on the side of the receiver, approximately a 1/2" (12.7 mm) below the rear of the trigger guard (Fig. 8).

Remove the trigger housing assembly by lifting the rear portion upward first.

 The trigger housing is a complex assembly and must not be disassembled. Disassembly should only be performed by the factory or a qualified gunsmith.

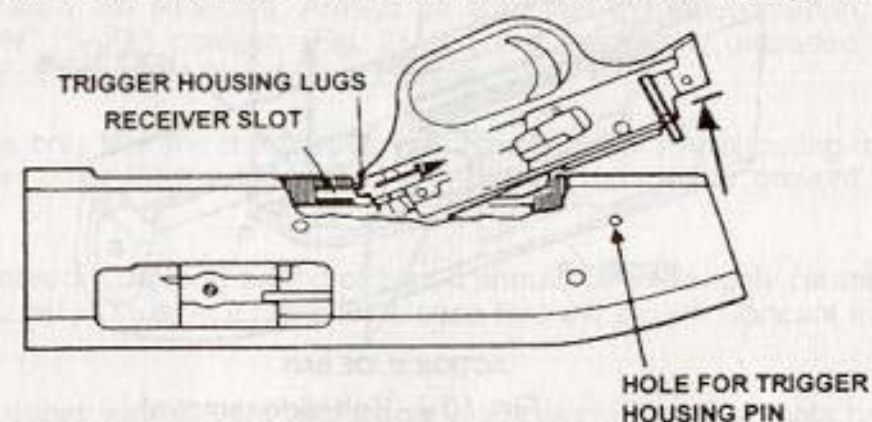



Fig. 8

 Do not pull the trigger and allow the hammer to fall when the trigger housing assembly is removed from the receiver. To do so may result in personal injury or damage to the assembly.

CAUTION: Before performing any further disassembly, take time to study how the internal components are arranged inside the receiver.

DISASSEMBLY OF INTERNAL RECEIVER COMPONENTS

CAUTION: Pay special attention to the position of the bolt, bolt slide and action slide bar assembly during this portion of the disassembly, as the parts must be in the same relationship during reassembly.

Remove the cartridge interrupter from the ejection port side and cartridge stop from the opposite side. (It may be necessary to tap the sides of the receiver lightly to release these parts) (Fig. 9).

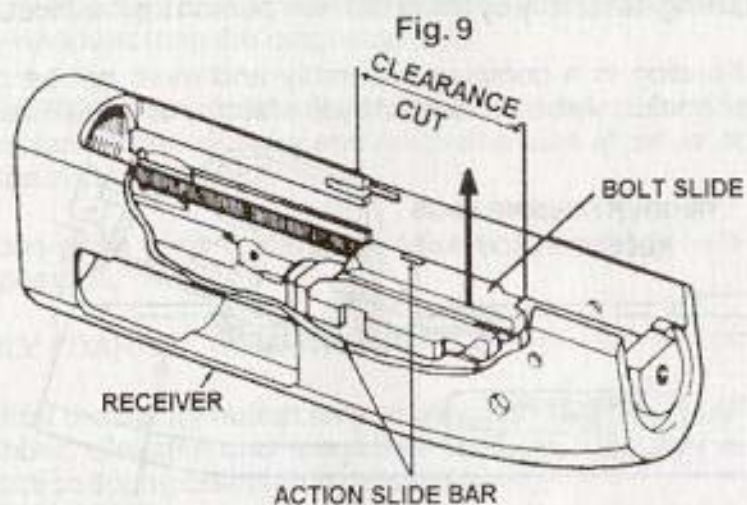
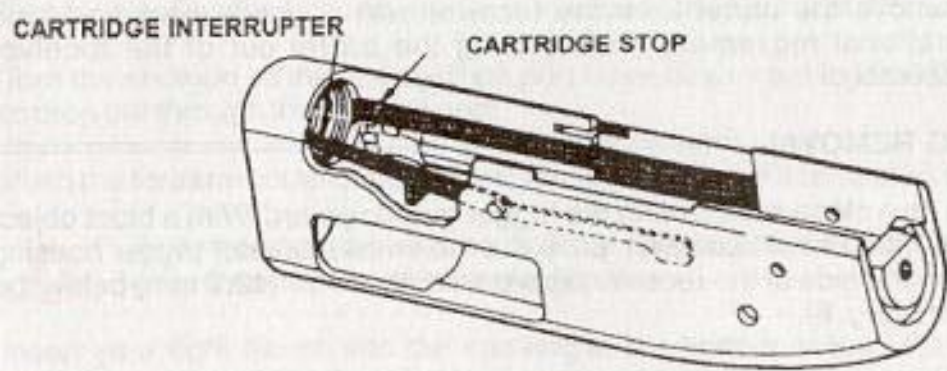

Fig. 10 — Bolt slide removal

Move the forearm/action slide assembly rearward so that the bolt assembly and bolt slide are three quarters of the way rearward. When the bottom of the bolt slide is aligned with the clearance cuts in the sides of the receiver, lift the bolt slide upward and out of the receiver (Fig. 10).

Remove the bolt assembly by sliding it forward and out of the receiver assembly through the barrel opening at the front of the receiver (Fig. 11-A).

NOTE: The safety button located on the upper rear of the receiver must be fully rearward in the "ON" (SAFE) position to remove the elevator assembly (Fig. 2).

Pivot the front portion of the elevator upward out of the receiver (Fig. 11-B). Squeeze the two arms which form the open end of the elevator assembly together sufficiently to disengage and remove the elevator from the receiver (Fig. 11-C).

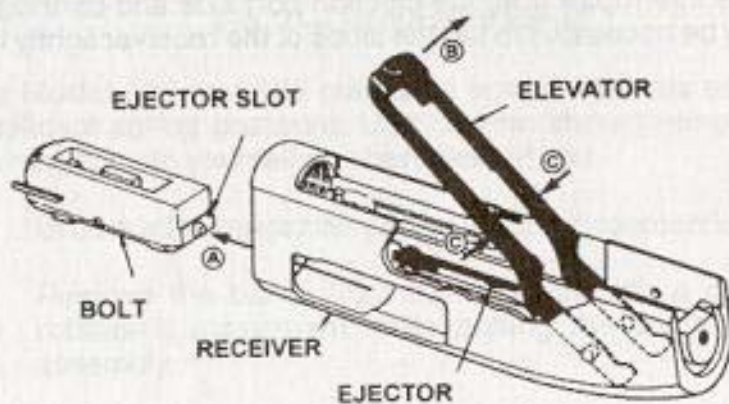

Fig. 11 — Elevator removal

Remove the forearm/action slide assembly by sliding it forward and off the magazine tube.



CAUTION: Field disassembly is now complete! The shotgun should not be disassembled further for routine cleaning or maintenance. Further disassembly should only be performed at the factory or by a qualified gunsmith.

CLEANING AND LUBRICATION

With proper care, your Mossberg shotgun will provide you with years of dependable service. Your firearm should be inspected and cleaned periodically to insure that it remains in good condition. Clean your firearm as soon as possible after use. This is especially important if your firearm has been exposed to moisture.

Use the instructions and equipment provided in a quality gun cleaning kit.

For maximum performance and continued satisfaction with your shotgun, periodic cleaning and lubrication are essential. Always be sure that the safety button is fully rearward in the "ON" (SAFE) position (Fig. 2) and that the gun is unloaded before cleaning your gun. Wear eye protection during cleaning.

Normal use requires only that the mechanisms be free of excessive shooting residue. Very little lubrication other than a light oiling of external surfaces to prevent rust is needed.

If the gun is to be stored for a long period of time it should be thoroughly cleaned and oiled. Do not plug barrel or store in a fabric lined case that will absorb lubricant from the gun.

Scrub bore and chamber with solvent and follow with cleaning patches until barrel is clean. A final pass with a lightly oiled patch will provide a protective coating. Clean and remove any deposits in the barrel extension.

All metal parts should be cleaned with gun solvent and lightly lubricated with gun oil. Over lubrication should be avoided. Use only lubricants specifically designed for firearms. Avoid the use of abrasives which may damage the metal finish.



Make sure the barrel is free of obstructions and excessive lubricant after cleaning.

Camo guns: Caution should be exercised to avoid exposure of camouflage pattern to strong solvents.

BOLT AND TRIGGER HOUSING ASSEMBLIES

The bolt and trigger housing assemblies are complex assemblies and should not be disassembled except by factory or qualified gunsmith.

Clean as complete assemblies with gun solvent and lightly lubricate with gun oil.

ASSEMBLY OF INTERNAL RECEIVER COMPONENTS

Place the receiver with the trigger housing opening upward on a clean surface.

Check to be certain that the safety button on the top rear of the receiver is fully rearward in the "ON" (SAFE) position (Fig. 2). Slide the forearm assembly onto the magazine tube while guiding the action slide bars into the corresponding cuts in the front of the receiver (Fig. 12).

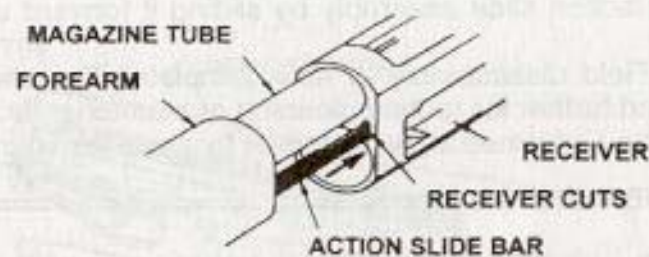

Fig. 12

Assemble the elevator by squeezing the arms together sufficiently to position them in the receiver so that the buttons on the elevator fit into the corresponding (1/4" [6.4 mm]) diameter holes in the receiver (Fig. 11).

Pivot the elevator so that the forward portion of the elevator is even with the outside edge of the cavity in the receiver.

Insert the rear of the bolt assembly, with its bolt lock downwards toward the front inside top of the receiver, into the barrel opening of the receiver. Depress the ejector (located in the side of the receiver opposite the ejection port) to allow the bolt assembly to slide fully rearward into the receiver.

The ejector must fit into the corresponding slot in the bolt (Fig. 11).

Push the elevator down until it rests against the bolt. Position the rear of the bolt assembly even with the rear of the clearance cuts in the sides of the receiver (Fig. 13-B).

Position action bars so the notch on the bar is even with the cuts on the inside receiver walls (Fig. 13-A).

The bolt slide should be positioned with the slotted side facing up, with notch to the rear (Fig. 13).

Assemble the bolt slide, lowering the front of the bolt slide first. The bolt slide protrusion fits into the corresponding cut on the bottom of the bolt lock and action bar slots (Fig. 13-C).

Hold the bolt slide down and pull the forearm assembly forward. The bolt and bolt slide should move freely in their cuts in the receiver. If parts do not slide easily — DO NOT FORCE — disassemble and reassemble, paying attention to the relationship of the bolt, bolt slide and action slide bars.

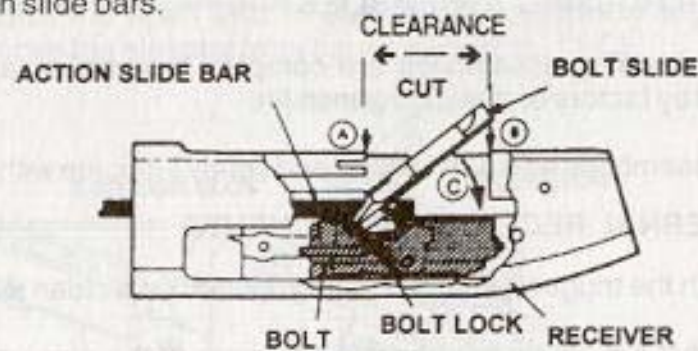

Fig. 13

Position the cartridge stop and cartridge interrupter in their proper places on the inside walls of the receiver (Fig. 9).

The hooks must face inward toward the center of the cavity away from the receiver walls.

TRIGGER HOUSING ASSEMBLY INSTALLATION

NOTE: Hammer must be in the fully-cocked position to allow the trigger housing to be inserted in the receiver.

Hold the cartridge stop and cartridge interrupter in place firmly against the receiver walls with one hand and grasp and trigger housing assembly with the other (Fig. 9).

Insert the lugs, on each side of the front corner of the trigger housing into the slots on each side of the receiver (Fig. 14- A), then ease the rear of the housing assembly down and into position (Fig. 14- B). DO NOT FORCE!

NOTE: If the trigger housing does not fit into place easily, check that all internal trigger housing pins are flush with the side of the housing and that the cartridge interrupter and cartridge stop are positioned properly.

Align the trigger pin hole in the housing assembly with those in the receiver. Insert the trigger housing pin and push in fully until flush with the side of the receiver (Fig. 14).

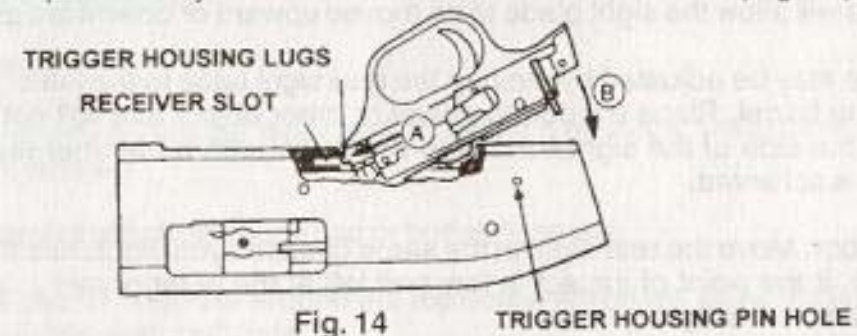

Fig. 14

FUNCTION TESTING



AFTER PERFORMING ANY WORK ON YOUR FIREARM SUCH AS CLEANING, DISASSEMBLY OR INSTALLATION OF AN ACCESSORY:

- Move the safety button fully rearward to the "ON" (SAFE) position and keep muzzle pointed in a safe direction.
- Open the action, check chamber, elevator and magazine tube to be certain firearm is unloaded.

Depress and hold the action lock lever (Fig. 3). Open and close the action several times to check for free movement of the action assembly.

Close the action (forearm fully forward) and leave the safety in the "ON" (SAFE) position. Pull the trigger rearward fully. The hammer should not fall (No Fire).

Remove your finger from the trigger. Move the safety to the "OFF" (FIRE) position. The hammer should not fall (No Fire).

Leave the safety in the "OFF" (FIRE) position.

Pull the trigger rearward. The hammer should fall (Fire).

Open the action by moving the forearm fully rearward. Move the safety fully rearward to the "ON" (SAFE) position.

! IF YOUR FIREARM DOES NOT PERFORM AS DESCRIBED IN ANY OF THE ABOVE STEPS, CONTACT O.F. MOSSBERG & SONS, INC., IMMEDIATELY. DO NOT ATTEMPT TO USE THE FIREARM.

SIGHT ADJUSTMENTS

- !** BEFORE MAKING ANY SIGHT ADJUSTMENTS:
- Move the safety button fully rearward to the "ON" (SAFE) position and keep muzzle pointed in a safe direction.
 - Open the action, check chamber, elevator and magazine tube to be certain firearm is unloaded.

RIFLE SIGHT ADJUSTMENTS

IRON SIGHTS:
Elevation may be adjusted by loosening the small screw in the center of the rear sight leaf. This will allow the sight blade to be moved upward or downward as required.

Windage may be adjusted by moving the rear sight base to the left or right in the dove tail slot in the barrel. Place a wooden dowel or other object that will not damage the finish, against the side of the sight base. Tap the dowel with a hammer until the desired sight location is achieved.

Remember: Move the rear sight in the same direction you would like the shot to move. For example, if the point of impact is low and left at the point of aim ... move the rear sight upward and to the right.

GHOST RING® SIGHT ADJUSTMENTS

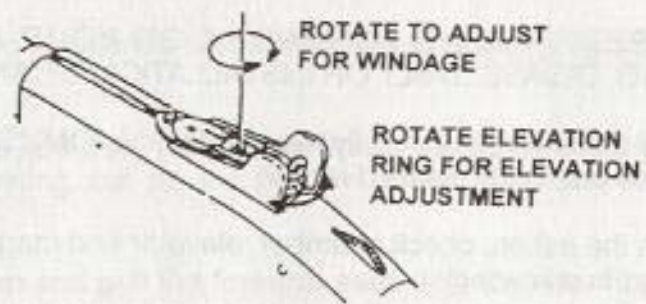

Fig. 15

Williams Style rear sight:

Elevation may be adjusted by loosening the smaller of the two screws on the rear sight leaf base. This will allow the sight leaf base to be raised or lowered by sliding the base up or down the rear sight ramp. Tighten screw after adjustment.

Windage may be adjusted by loosening the larger of the two screws and sliding the sight leaf left or right in the sight leaf base. Tighten screw after adjustment.

Remember: Move the rear sight in the same direction you would like the shot to move. For example, if the point of impact is low and left of the point of aim... move the rear sight upward and to the right.

MOSSBERG ACCESSORY BARRELS

! Accessory barrels are interchangeable only within specific model, gauge and magazine capacity.

Model 500: HS410 barrels are not interchangeable with standard Model 500 .410 bore sporting barrels.

PISTOL GRIP INSTALLATION

! BEFORE PERFORMING ANY DISASSEMBLY OR ASSEMBLY PROCEDURE:

- Move the safety button fully rearward to the "ON" (SAFE) position and keep muzzle pointed in a safe direction.
- Open the action, check chamber, elevator and magazine tube to be certain firearm is unloaded.

To Remove Buttstock:

- Loosen the top screw holding the recoil pad or buttplate on stock. Note: Most models use Phillips head screws.
- Loosen and remove the bottom recoil pad or buttplate screw.
- Swing the recoil pad or buttplate around the top screw which will allow access to the stock bolt through the stock butt hole.
- Check stock bolt head configuration. Some models use a slotted head, others use a 1/2 in. hex head.
- Loosen and remove stock bolt by turning it counterclockwise. The stock may now be removed from the receiver.

Installation of Pistol Grip:

- Align mounting hole in pistol grip with threaded hole in rear of the receiver.
- Slip washers on bolt. Insert bolt through pistol grip into hole in receiver. Finger tighten bolt to insure threads are properly engaged. If you encounter difficulty, unscrew both and repeat procedure.
- Using Allen wrench supplied, tighten bolt very snugly.

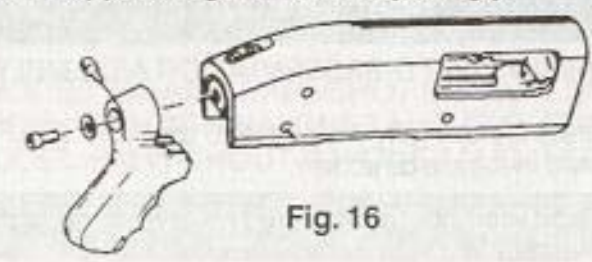

Fig. 16

! Upon firing, recoil force will cause the gun to move rearward and upward. Never hold the gun at eye level and attempt to sight down the barrel. To avoid possible injury, grip the gun securely with one hand on the forearm and one hand on the pistol grip. Pistol grip models are designed to be held at waist level when firing.

SPEEDFEED STOCK

BEFORE CLEANING OR REMOVING THE SPEEDFEED STOCK:

- Move the safety button fully rearward to the "ON" (SAFE) position and keep muzzle pointed in a safe direction.
- Open the action, check chamber, elevator and magazine tube to be certain firearm is unloaded.

The stock springs and followers should be removed periodically and the tube and parts cleaned to remove debris. Do not lubricate these parts.

The recoil pad on the speedfeed stock is under spring pressure. Remove rounds from storage tubes to minimize the spring pressure. Use caution when removing recoil pad screws to prevent injury to yourself or others around you.

- Loosen and remove the two recoil pad screws by turning them counterclockwise.
- Remove recoil pad, springs and plastic followers. Place on a clean dry surface.

TO REASSEMBLE

- Insert one plastic follower into each magazine tube in the stock. Be sure the hollow portion of the follower is facing toward the rear of the stock.
- Insert one spring in each of the two magazine tubes. The springs will fit inside the cupped end of the followers inserted in the previous step.
- Screw the recoil pad screws into the recoil pad until the screw points come through the opposite side about 1/8 of an inch. Place the pad against the springs so that the end of each spring rests against the recessed area on the pad.
- Compress the springs into the tubes by pushing the pad flush against the stock. Adjust the pad until you feel the points of the screws fit into the pre-drilled holes in the stock.
- While maintaining pressure on the pad, tighten the recoil pad screws securely. Do not overtighten screws.
- Check for free movement of the followers by pushing them into the magazine tube with your finger and allowing them to snap back into position under spring pressure.

HEAT SHIELD

BEFORE PERFORMING ANY DISASSEMBLY OR ASSEMBLY PROCEDURE:

- Move the safety button fully rearward to the "ON" (SAFE) position and keep muzzle pointed in a safe direction.
- Open the action, check chamber, elevator and magazine tube to be certain firearm is unloaded.

HEAT SHIELD INSTALLATION

NOTE: The heat shield can only be installed on 12 ga., plain barrel models. Heat shield will not fit on barrels with Ghost Ring sights.

- Follow barrel removal procedures as described in this Owner's Manual.

- Carefully remove front sight by turning it counterclockwise. Take precautions to insure you do not damage the barrel finish.
- Slide heat shield onto barrel from muzzle end. Large ring on heat shield is positioned towards rear of barrel.
- With the heat shield on the barrel, use a small padded "C" clamp or a vise, to close the forward clamp of the heat shield.
- Position the appropriate length plastic spacer or optional bushing style spacers between the forward clamp. Insert the two screws and start the two hex nuts on the screws using a 7/64" hex key wrench and a 5/16" open end or box wrench. DO NOT FULLY TIGHTEN THE TWO SCREWS YET (Fig. 17).
- Reassemble barrel to action.

When securing heat shield, barrel must be attached to shotgun. Barrels with heat shield secured are not interchangeable without proper refitting of heat shield to gun as described in the above procedure.

Make sure takedown screw is secure and the barrel is fully seated before proceeding to the next step.

- Position heat shield so that the rear (large ring) butts up against the front of the receiver.
- Using a 7/64" Allen wrench and a 5/16" open end or box wrench, tighten the clamp screws to securely hold the heat shield in place. DO NOT OVERTIGHTEN THE SCREWS.
- Reinstall front sight.

Whenever the heat shield barrel is removed from the gun, repeat the above steps 5-8 to insure that the shield is not preventing the barrel from being seated fully.

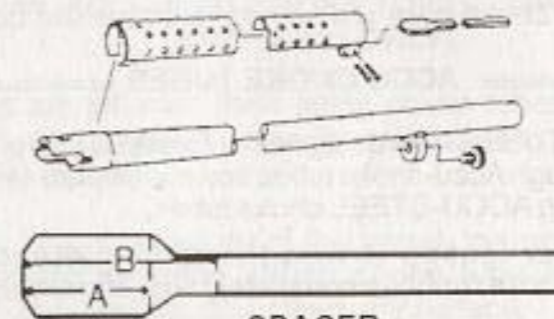

SPACER

Fig. 17

MODEL 500 AND 590 6-SHOT CUT AT 1 5/16" (A)
MODEL 590 WITH BAYONET LUG CUT AT 1 7/8" (B)
MODEL 590 WITHOUT BAYONET LUG, USE AS IS.

DUAL - COMB® TROPHY STOCK

BEFORE PERFORMING ANY DISASSEMBLY OR ASSEMBLY PROCEDURE:

- Move the safety button fully rearward to the "ON" (SAFE) position and keep muzzle pointed in a safe direction.
- Open the action, check chamber, elevator and magazine tube to be certain firearm is unloaded.

To Change Removable Combs:

- 1) Using a 3/16 in. Allen head wrench (supplied) unscrew and remove the comb retaining screw found at the top center of the removable comb.
- 2) Place the desired comb into position. Insert the comb retaining screw and snug-tighten. Do not overtighten as this will damage the internal assembly components.

ACCU, ACCU-STEEL, ACCU-MAG CHOKE TUBES



BEFORE REMOVING OR INSTALLING ANY CHOKE TUBE:

- a. Move the safety button fully rearward to the "ON" (SAFE) position and keep muzzle pointed in a safe direction.
- b. Open the action, check chamber, elevator and magazine tube to be certain firearm is unloaded.



Do not use bent or deformed tubes as these may result in tube or barrel damage upon firing. Inspect tubes periodically to insure they are properly installed and in good condition. Pay special attention to the threaded end of the tube to be certain it is not deformed or dented.



Never fire the gun without a choke tube properly installed. Failure to do so will damage the precision threads on the inside of the barrel.

CARE & CLEANING: The precision threads on your choke tube should be kept clean and lightly oiled at all times.

During cleaning of the barrel, be certain a choke tube is properly installed. This will avoid residue build-up on threads.

Extra-Full choke tubes are not recommended for use with buckshot or slugs.

The "Improved Cylinder" choke tube will usually produce the best accuracy with most slugs.

ACCU CHOKE TUBES



ACCU-CHOKE TUBES - are designed for Best Lead Shot Patterns. STEEL SHOT can be fired through Accu-choke tubes however, better steel shot patterns may be obtained by using ACCU-STEEL choke tubes.

To **remove** choke tube, loosen it with the choke wrench provided, turning counterclockwise. When loose, remove completely with fingers, put choke on a clean dry surface.

To **install** choke tube, first screw the tube clockwise into barrel by hand and then tighten the tube until snug with a choke wrench. Do not use excessive force when installing. Tube tightness should be checked periodically. Accu tubes fit completely inside the muzzle of the barrel when fully installed.

ACCU CHOKE TUBES

GAUGE	ITEM #	LEAD SHOT PATTERNS
12	95190	Full
12	95195	Modified
12	95200	Imp. Cylinder
20	95215	Full
20	95220	Modified
20	95225	Imp. Cylinder
12	95235	Skeet
12	95267	XX Full (Turkey Tube)
12	95245	Improved Modified

ACCU-STEEL CHOKE TUBES

ACCU-STEEL TUBES - have been specifically designed for exceptional endurance and controlled patterning of steel shot.

These tubes should provide the best pattern results for the steel shot sizes stamped on each tube.

Lead shot may be used with ACCU-STEEL tubes; however, pattern tests should be made to compare the pattern change.

To **remove** choke tube, loosen with the choke wrench provided, turning counterclockwise. When loose, remove completely with fingers, put choke on a clean dry surface.

To **install** choke tube, first screw the tube clockwise into barrel by hand and then tighten the tube until snug with a choke wrench. Do not use excessive force when installing. Tube tightness should be checked periodically.

ACCU-STEEL tubes protrude beyond the muzzle and are designed specifically for **steel shot**. Choke designations are marked on each tube for specific steel shot sizes.

ACCU-STEEL CHOKE TUBES

GAUGE	ITEM#	STEEL SHOT PATTERNS
12	95110	Full for T,F,BB,#1,2
12	95115	Full for #4,6
12	95117	Extra-Full for T,F,BB,#1,2
12	95120	Modified for All Steel Shot Sizes
20	95125	Full for #4,6
20	95130	Modified for All Steel Shot Sizes

ACCU-MAG CHOKE TUBES (MODEL 835 ONLY)

ACCU-MAG choke tubes are internal, flush fitting choke tubes designed for use with LEAD, STEEL shot. Each durable tube is clearly marked, as a guide, with the lead and the steel shot pattern it will produce.

To **remove** a choke tube from the muzzle of the barrel, loosen with the choke wrench provided, turning it counterclockwise. When choke tube is loosened, remove it completely with fingers. Put choke tube on a clean, dry surface.

To **install** choke tube, screw the tube clockwise into barrel by hand and then tighten the tube until snug with choke wrench. These tubes fit completely inside the barrel when properly installed. Do not use excessive force when installing. Tube tightness should be checked periodically.

12 GA. MODEL 835 ACCU-MAG CHOKE TUBES

ITEM #	LEAD SHOT PATTERN *	YDS	STEEL SHOT PATTERN	YDS
95256	Skeet	40	Skeet	40
95252	Imp. Cyl.	40	Mod. T&F	40
95253	Modified	40	Mod. #2 & BB	40
95254	Full	40	Full, #2 & BB	40
95255			Extra Full T&F	40
95257	Ulti-Full	30		

• **Lead shot** patterns will vary substantially with the extra-full steel shot tube depending on shell length, shot size, brand of ammunition and the individual barrel. The shooter is urged to conduct **lead shot** pattern tests with this tube before field use.

 **SLUGS:** Overbored **Model 835** Accu-Mag barrels are designed for lead or steel pellet shot loads only. We specifically disclaim any responsibility for damage or injury resulting from firing slugs (single projectile ammunition) through overbored barrels. Use only **Model 835** barrels designed specifically for slug shooting.

=====**ACCU-MAG, LEAD SHOT, ULTI-FULL TUBE**=====

The NATIONAL WILD TURKEY FEDERATION has determined that the average distance at which turkeys are most effectively taken, under average environmental conditions and surroundings is 30 yards.

Subsequently Mossberg designed and manufactured this highly specialized choke tube for #4 or #6 lead shot to yield a high core concentration and high pellet count in a 20 inch circle at 30 yards. Shot patterns at distances greater than 30 yards will be less dense.

These special purpose "**Turkey Tubes**" are specifically designed for use with **Lead Shot** loads only.

 Do not shoot steel shot through Extra Full turkey tubes as it may result in barrel damage.

Test results are averages and individual shotgun performance may vary. We recommend pattern tests with several brands of ammo and at various distances to familiarize yourself with your shotguns performance at various distances.

MUZZLELOADER CONVERSION BARREL

 Do not attempt to assemble, load or use the Muzzleloading barrel until you thoroughly read and understand the information contained in this shotgun Owner's Manual and the contents of the Muzzleloading Barrel Owner's Manual.

 You have a responsibility to obtain proper training on how to use and maintain your firearm. Certified and reputable instructions are offered by the National Rifle Association, The National Muzzleloading Rifle Association, Black Powder Association as well as state and local organizations. Seek guidance from an instructor who is qualified by one of these organizations.

 Be certain the shotgun Owner's Manual and the Muzzleloading Barrel Owner's manual are available for reference and supplied with the shotgun and/or the Muzzleloading Barrel if transferred to another party.

 If either manual is lost or misplaced, request a free replacement copy from Mossberg.

Consult your local Wildlife or Department of Natural Resources guidelines to confirm that this muzzleloading product will conform to local seasonal and legal requirements.

SERVICE INSTRUCTIONS

Should your firearm, or any component of your firearm require service, kindly ship your entire firearm (please do not send components only), via your chosen carrier, postage paid (we do not accept C.O.D. shipments) following these instructions:

- 
- **Make absolutely certain your gun is unloaded.**
 - **Do not send ammunition with your gun.**
 - Remove all accessories from your firearm such as scopes, slings, swivels, mounts, etc.
 - Ship your firearm in a suitable container, packaging it securely to prevent parts from shifting and/or harm during shipping.
 - Include a note with a clear description of the service you wish us to perform, your complete return shipping address (no P.O. boxes please), your daytime telephone number and your e-mail address (if available). It is advisable to place your correspondence inside your shipping container when shipping.

SHIPPING ADDRESS

Mossberg Service Center
1001 Industrial Blvd.
Eagle Pass Industrial Park
Eagle Pass, TX 78853
Attn: Repair

If you have any questions, please contact us at 203-230-5300 or service@mossberg.com

TO ORDER PARTS FROM US

To order parts from our factory, you can fax, phone, mail, or e-mail your order to us at one of the below numbers/addresses.

Fax Number: (830) 773-5893
Phone Number: (830) 773-9007
E-mail Address: service@mossberg.com
Mailing Address: Mossberg Service Center
1001 Industrial Blvd.
Eagle Pass Industrial Park
Eagle Pass, TX 78853
Attention: Order Department

Please provide your name, address, city, state, zip, your daytime phone number and e-mail address. We'll need Model #, Serial #, Gauge/Caliber, Finish, Part # and Part Name. We have a \$7.50 (U.S.) minimum parts order charge. We accept most major credit cards, personal checks, money orders, and bank drafts.

Service outside of the U.S.A.

For Mossberg firearm parts and service requirements outside of the United States, customers are requested to contact the closest Mossberg stocking dealer/distributor.

PARTS LIST

ITEM NO.	DESCRIPTION	ITEM NO.	DESCRIPTION
1.	Recoil pad screw	22.	Ejector
2.	Recoil Pad	23.	Ejector screw
3.	Spacer	24.	Magazine follower
4.	Stock bolt	25.	Magazine spring
5.	Lock washer	26.	Magazine tube
6.	Flat Washer	27.	Retaining 'O' ring
7.	Stock	28.	Limiting plug
8.	Stock swivel Q.D. post	29.	Action slide assembly
9.	Speedfeed springs	30.	Action slide tube nut
10.	Speedfeed followers	31.	Forearm
11.	Speedfeed stock	32.	Barrel assembly
14.	Trigger housing pin	33.	Mid-point bead
* 15.	Receiver	34.	Front sight
* 16.	Trigger housing assembly	35.	Takedown screw (Model 500)
* 17.	Bolt assembly	36.	Barrel Q.D. swivel post
* 18.	Bolt slide	37.	Rear rifle sight assembly
19.	Elevator	38.	Magazine cap
20.	Cartridge stop	39.	Heat shield
21.	Cartridge interrupter	40.	Heat shield screw/nuts
		41.	Heat shield spacer

*Items marked with an asterisk on parts list are reserved for qualified gunsmiths only.

EXPLODED VIEW

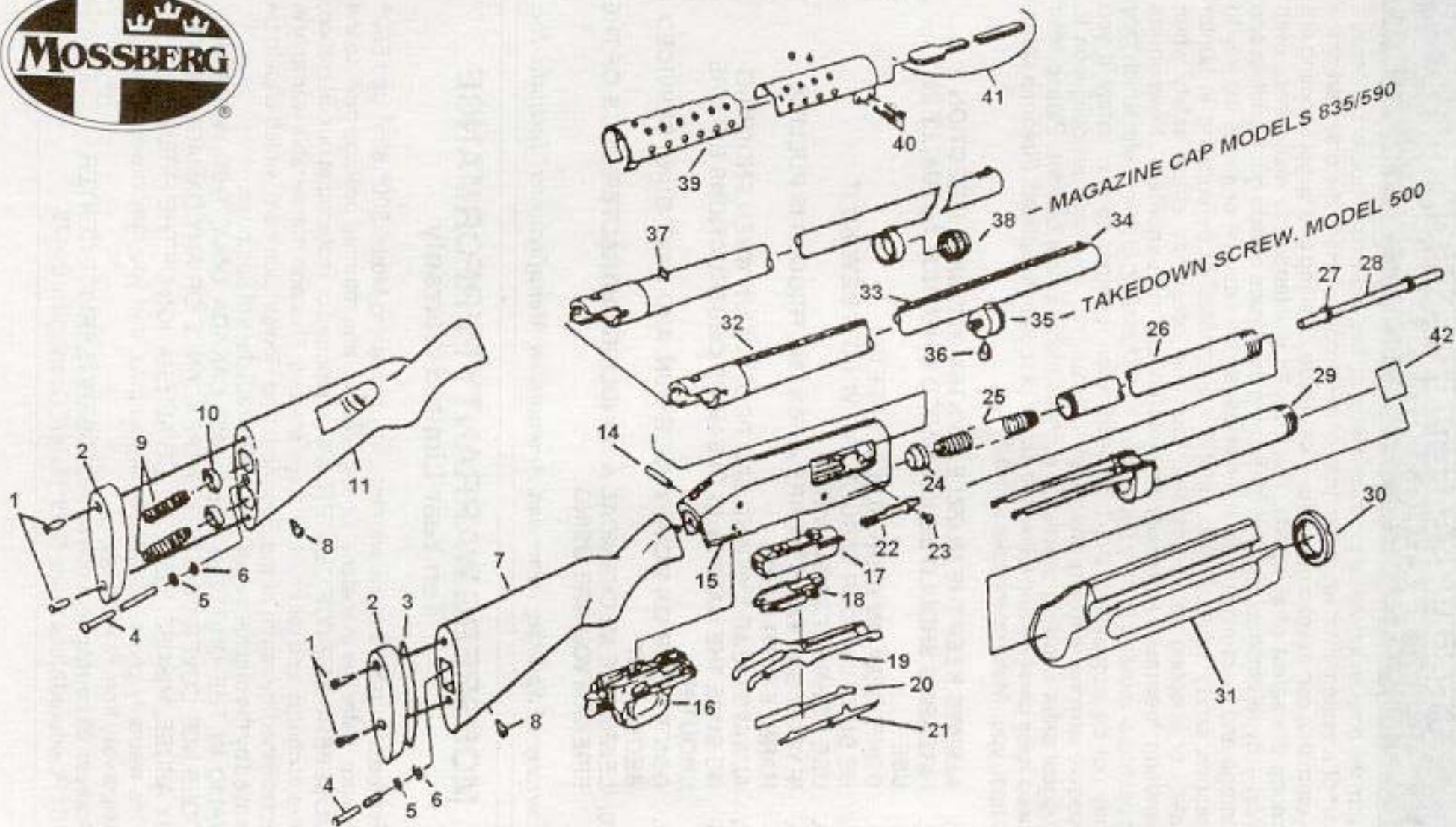

FIREARMS SAFETY DEPENDS ON YOU. MAKE NO MISTAKE ABOUT !

From the time an individual picks up a firearm, that individual shooter becomes a part of a system over which he has complete control. He is the only part of the system that can make a gun safe — or unsafe. Hunting and target shooting are among the safest of all sports. This booklet is intended to make them even safer— by re-emphasizing and reaffirming the basics of safe gun handling and storage and by reminding each individual shooter that he or she is the key to firearms safety. You can help meet this responsibility by enrolling in hunter safety or shooting safety courses. You must constantly stress safety when handling firearms, especially to children and non-shooters. Newcomers in particular must be closely supervised when handling firearms with which they may not be acquainted. Don't be timid when it comes to gun safety. If you observe anyone violating any safety precautions, you have an obligation to suggest safer handling practices, such as those in this booklet. Please read these rules carefully and follow the safety procedures outlined. Firearms safety is up to you. Make no mistake about it.

- 1. ALWAYS KEEP THE MUZZLE POINTED IN A SAFE DIRECTION**
- 2. FIREARMS SHOULD BE UNLOADED WHEN NOT ACTUALLY IN USE**
- 3. DON'T RELY ON YOUR GUN'S "SAFETY"**
- 4. BE SURE OF YOUR TARGET AND WHAT'S BEYOND IT**
- 5. USE CORRECT AMMUNITION**
- 6. IF YOUR GUN FAILS TO FIRE WHEN THE TRIGGER IS PULLED, HANDLE WITH CARE**
- 7. ALWAYS WEAR EYE AND EAR PROTECTION WHEN SHOOTING**
- 8. BE SURE THE BARREL IS CLEAR OF OBSTRUCTIONS BEFORE SHOOTING**
- 9. DON'T ALTER OR MODIFY YOUR GUN, AND HAVE GUNS SERVICED REGULARLY**
- 10. LEARN THE MECHANICAL & HANDLING CHARACTERISTICS OF THE FIREARM YOU ARE USING**

Courtesy of Sporting Arms and Ammunition Manufacturers' Institute, Inc.

MOSSBERG WARRANTY PERFORMANCE Ten Year Limited Warranty

For the time period of the warranty, any Mossberg Model 500[®], 835[®] and 590[®] firearm, defective in material or manufacture and returned postage paid, to the MOSSBERG SERVICE CENTER, will be repaired or replaced at our discretion, free of charge and returned, postage prepaid. This non-transferable warranty is established by return of the Research and Registration card, which should be mailed by the original owner within thirty (30) days of purchase.

VALID IN THE UNITED STATES AND CANADA ONLY, THIS WARRANTY DOES NOT COVER COSMETIC APPEARANCE OR ANY DAMAGE CAUSED BY ABUSE, MISUSE, NEGLIGENCE, OR ALTERATION OF THE FIREARM.

This warranty gives you specific legal rights, and you may have other rights which vary from State to State.

Address all correspondence to: MOSSBERG SERVICE CENTER,
101 Powdered Metal Drive, North Haven, Connecticut 06473.