

**SOLUTIONS MANUAL**

to accompany

**ORBITAL MECHANICS FOR ENGINEERING STUDENTS**

**Howard D. Curtis**

*Embry-Riddle Aeronautical University  
Daytona Beach, Florida*

**Problem 1.1**

(a)

$$\begin{aligned}
\mathbf{A} \cdot \mathbf{A} &= (A_x \hat{\mathbf{i}} + A_y \hat{\mathbf{j}} + A_z \hat{\mathbf{k}}) \cdot (A_x \hat{\mathbf{i}} + A_y \hat{\mathbf{j}} + A_z \hat{\mathbf{k}}) \\
&= A_x \hat{\mathbf{i}} \cdot (A_x \hat{\mathbf{i}} + A_y \hat{\mathbf{j}} + A_z \hat{\mathbf{k}}) + A_y \hat{\mathbf{j}} \cdot (A_x \hat{\mathbf{i}} + A_y \hat{\mathbf{j}} + A_z \hat{\mathbf{k}}) + A_z \hat{\mathbf{k}} \cdot (A_x \hat{\mathbf{i}} + A_y \hat{\mathbf{j}} + A_z \hat{\mathbf{k}}) \\
&= [A_x^2 (\hat{\mathbf{i}} \cdot \hat{\mathbf{i}}) + A_x A_y (\hat{\mathbf{i}} \cdot \hat{\mathbf{j}}) + A_x A_z (\hat{\mathbf{i}} \cdot \hat{\mathbf{k}})] + [A_y A_x (\hat{\mathbf{j}} \cdot \hat{\mathbf{i}}) + A_y^2 (\hat{\mathbf{j}} \cdot \hat{\mathbf{j}}) + A_y A_z (\hat{\mathbf{j}} \cdot \hat{\mathbf{k}})] \\
&\quad + [A_z A_x (\hat{\mathbf{k}} \cdot \hat{\mathbf{i}}) + A_z A_y (\hat{\mathbf{k}} \cdot \hat{\mathbf{j}}) + A_z^2 (\hat{\mathbf{k}} \cdot \hat{\mathbf{k}})] \\
&= [A_x^2 (1) + A_x A_y (0) + A_x A_z (0)] + [A_y A_x (0) + A_y^2 (1) + A_y A_z (0)] + [A_z A_x (0) + A_z A_y (0) + A_z^2 (1)] \\
&= A_x^2 + A_y^2 + A_z^2
\end{aligned}$$

But, according to the Pythagorean Theorem,  $A_x^2 + A_y^2 + A_z^2 = A^2$ , where  $A = \|\mathbf{A}\|$ , the magnitude of the vector  $\mathbf{A}$ . Thus  $\mathbf{A} \cdot \mathbf{A} = A^2$ .

(b)

$$\begin{aligned}
\mathbf{A} \cdot (\mathbf{B} \times \mathbf{C}) &= \mathbf{A} \cdot \begin{vmatrix} \hat{\mathbf{i}} & \hat{\mathbf{j}} & \hat{\mathbf{k}} \\ B_x & B_y & B_z \\ C_x & C_y & C_z \end{vmatrix} \\
&= (A_x \hat{\mathbf{i}} + A_y \hat{\mathbf{j}} + A_z \hat{\mathbf{k}}) \cdot [\hat{\mathbf{i}}(B_y C_z - B_z C_y) - \hat{\mathbf{j}}(B_x C_z - B_z C_x) + \hat{\mathbf{k}}(B_x C_y - B_y C_x)] \\
&= A_x (B_y C_z - B_z C_y) - A_y (B_x C_z - B_z C_x) + A_z (B_x C_y - B_y C_x)
\end{aligned}$$

or

$$\mathbf{A} \cdot (\mathbf{B} \times \mathbf{C}) = A_x B_y C_z + A_y B_z C_x + A_z B_x C_y - A_x B_z C_y - A_y B_x C_z - A_z B_y C_x \quad (1)$$

Note that  $(\mathbf{A} \times \mathbf{B}) \cdot \mathbf{C} = \mathbf{C} \cdot (\mathbf{A} \times \mathbf{B})$ , and according to (1)

$$\mathbf{C} \cdot (\mathbf{A} \times \mathbf{B}) = C_x A_y B_z + C_y A_z B_x + C_z A_x B_y - C_x A_z B_y - C_y A_x B_z - C_z A_y B_x \quad (2)$$

The right hand sides of (1) and (2) are identical. Hence  $\mathbf{A} \cdot (\mathbf{B} \times \mathbf{C}) = (\mathbf{A} \times \mathbf{B}) \cdot \mathbf{C}$ .

(c)

$$\begin{aligned}
\mathbf{A} \times (\mathbf{B} \times \mathbf{C}) &= (A_x \hat{\mathbf{i}} + A_y \hat{\mathbf{j}} + A_z \hat{\mathbf{k}}) \times \begin{vmatrix} \hat{\mathbf{i}} & \hat{\mathbf{j}} & \hat{\mathbf{k}} \\ B_x & B_y & B_z \\ C_x & C_y & C_z \end{vmatrix} = \begin{vmatrix} \hat{\mathbf{i}} & \hat{\mathbf{j}} & \hat{\mathbf{k}} \\ A_x & A_y & A_z \\ B_y C_z - B_z C_y & B_z C_x - B_x C_y & B_x C_y - B_y C_x \end{vmatrix} \\
&= [A_y (B_x C_y - B_y C_x) - A_z (B_z C_x - B_x C_z)] \hat{\mathbf{i}} + [A_z (B_y C_z - B_z C_y) - A_x (B_x C_y - B_y C_x)] \hat{\mathbf{j}} \\
&\quad + [A_x (B_z C_x - B_x C_z) - A_y (B_y C_z - B_z C_y)] \hat{\mathbf{k}} \\
&= (A_y B_x C_y + A_z B_x C_z - A_y B_y C_x - A_z B_z C_x) \hat{\mathbf{i}} + (A_x B_y C_x + A_z B_y C_z - A_x B_x C_y - A_z B_z C_y) \hat{\mathbf{j}} \\
&\quad + (A_x B_z C_x + A_y B_z C_y - A_x B_x C_z - A_y B_y C_z) \hat{\mathbf{k}} \\
&= [B_x (A_y C_y + A_z C_z) - C_x (A_y B_y + A_z B_z)] \hat{\mathbf{i}} + [B_y (A_x C_x + A_z C_z) - C_y (A_x B_x + A_z B_z)] \hat{\mathbf{j}} \\
&\quad + [B_z (A_x C_x + A_y C_y) - C_z (A_x B_x + A_y B_y)] \hat{\mathbf{k}}
\end{aligned}$$

Add and subtract the underlined terms to get

$$\begin{aligned}
\mathbf{A} \times (\mathbf{B} \times \mathbf{C}) &= \left[ B_x (A_y C_y + A_z C_z + \underline{A_x C_x}) - C_x (A_y B_y + A_z B_z + \underline{A_x B_x}) \right] \hat{\mathbf{i}} \\
&\quad + \left[ B_y (A_x C_x + A_z C_z + \underline{A_y C_y}) - C_y (A_x B_x + A_z B_z + \underline{A_y B_y}) \right] \hat{\mathbf{j}} \\
&\quad + \left[ B_z (A_x C_x + A_y C_y + \underline{A_z C_z}) - C_z (A_x B_x + A_y B_y + \underline{A_z B_z}) \right] \hat{\mathbf{k}} \\
&= (B_x \hat{\mathbf{i}} + B_y \hat{\mathbf{j}} + B_z \hat{\mathbf{k}}) (A_x C_x + A_y C_y + A_z C_z) - (C_x \hat{\mathbf{i}} + C_y \hat{\mathbf{j}} + C_z \hat{\mathbf{k}}) (A_x B_x + A_y B_y + A_z B_z)
\end{aligned}$$

or

$$\mathbf{A} \times (\mathbf{B} \times \mathbf{C}) = \mathbf{B}(\mathbf{A} \cdot \mathbf{C}) - \mathbf{C}(\mathbf{A} \cdot \mathbf{B})$$

**Problem 1.2** Using the interchange of Dot and Cross we get

$$(\mathbf{A} \times \mathbf{B}) \cdot (\mathbf{C} \times \mathbf{D}) = [(\mathbf{A} \times \mathbf{B}) \times \mathbf{C}] \cdot \mathbf{D}$$

But

$$[(\mathbf{A} \times \mathbf{B}) \times \mathbf{C}] \cdot \mathbf{D} = -[\mathbf{C} \times (\mathbf{A} \times \mathbf{B})] \cdot \mathbf{D} \quad (1)$$

Using the *bac - cab* rule on the right, yields

$$[(\mathbf{A} \times \mathbf{B}) \times \mathbf{C}] \cdot \mathbf{D} = -[\mathbf{A}(\mathbf{C} \cdot \mathbf{B}) - \mathbf{B}(\mathbf{C} \cdot \mathbf{A})] \cdot \mathbf{D}$$

or

$$[(\mathbf{A} \times \mathbf{B}) \times \mathbf{C}] \cdot \mathbf{D} = -(\mathbf{A} \cdot \mathbf{D})(\mathbf{C} \cdot \mathbf{B}) + (\mathbf{B} \cdot \mathbf{D})(\mathbf{C} \cdot \mathbf{A}) \quad (2)$$

Substituting (2) into (1) we get

$$[(\mathbf{A} \times \mathbf{B}) \times \mathbf{C}] \cdot \mathbf{D} = (\mathbf{A} \cdot \mathbf{C})(\mathbf{B} \cdot \mathbf{D}) - (\mathbf{A} \cdot \mathbf{D})(\mathbf{B} \cdot \mathbf{C})$$

### Problem 1.3

#### Velocity analysis

From Equation 1.38,

$$\mathbf{v} = \mathbf{v}_o + \boldsymbol{\Omega} \times \mathbf{r}_{\text{rel}} + \mathbf{v}_{\text{rel}} \quad (1)$$

From the given information we have

$$\mathbf{v}_o = -10\hat{\mathbf{i}} + 30\hat{\mathbf{j}} - 50\hat{\mathbf{k}} \quad (2)$$

$$\mathbf{r}_{\text{rel}} = \mathbf{r} - \mathbf{r}_o = (150\hat{\mathbf{i}} - 200\hat{\mathbf{j}} + 300\hat{\mathbf{k}}) - (300\hat{\mathbf{i}} + 200\hat{\mathbf{j}} + 100\hat{\mathbf{k}}) = -150\hat{\mathbf{i}} - 400\hat{\mathbf{j}} + 200\hat{\mathbf{k}} \quad (3)$$

$$\boldsymbol{\Omega} \times \mathbf{r}_{\text{rel}} = \begin{vmatrix} \hat{\mathbf{i}} & \hat{\mathbf{j}} & \hat{\mathbf{k}} \\ 0.6 & -0.4 & 1.0 \\ -150 & -400 & 200 \end{vmatrix} = 320\hat{\mathbf{i}} - 270\hat{\mathbf{j}} - 300\hat{\mathbf{k}} \quad (4)$$

$$\begin{aligned}
\mathbf{v}_{\text{rel}} &= -20\hat{\mathbf{i}} + 25\hat{\mathbf{j}} + 70\hat{\mathbf{k}} \\
&= -20(0.57735\hat{\mathbf{i}} + 0.57735\hat{\mathbf{j}} + 0.57735\hat{\mathbf{k}}) \\
&\quad + 25(-0.74296\hat{\mathbf{i}} + 0.66475\hat{\mathbf{j}} + 0.078206\hat{\mathbf{k}}) \\
&\quad + 70(-0.33864\hat{\mathbf{i}} - 0.47410\hat{\mathbf{j}} + 0.81274\hat{\mathbf{k}})
\end{aligned}$$

so that

$$\mathbf{v}_{\text{rel}} = -53.826\hat{\mathbf{i}} - 28.115\hat{\mathbf{j}} + 47.300\hat{\mathbf{k}} \text{ (m/s)} \quad (5)$$

Substituting (2), (3), (4) and (5) into (1) yields

$$\mathbf{v} = (-10\hat{\mathbf{i}} + 30\hat{\mathbf{j}} - 50\hat{\mathbf{k}}) + (320\hat{\mathbf{i}} - 270\hat{\mathbf{j}} - 300\hat{\mathbf{k}}) + (-53.826\hat{\mathbf{i}} - 28.115\hat{\mathbf{j}} + 47.300\hat{\mathbf{k}})$$

$$\begin{aligned}
\mathbf{v} &= 256.17\hat{\mathbf{i}} - 268.12\hat{\mathbf{j}} - 302.7\hat{\mathbf{k}} \\
&= \underline{478.68(0.53516\hat{\mathbf{i}} - 0.56011\hat{\mathbf{j}} - 0.63236\hat{\mathbf{k}})} \text{ (m/s)}
\end{aligned}$$

### Acceleration analysis

From Equation 1.42,

$$\mathbf{a} = \mathbf{a}_O + \dot{\boldsymbol{\Omega}} \times \mathbf{r}_{\text{rel}} + \boldsymbol{\Omega} \times (\boldsymbol{\Omega} \times \mathbf{r}_{\text{rel}}) + 2\boldsymbol{\Omega} \times \mathbf{v}_{\text{rel}} + \mathbf{a}_{\text{rel}} \quad (6)$$

Using the given data together with (4) and (5) we obtain

$$\mathbf{a}_O = 25\hat{\mathbf{i}} + 40\hat{\mathbf{j}} - 15\hat{\mathbf{k}} \quad (7)$$

$$\dot{\boldsymbol{\Omega}} \times \mathbf{r}_{\text{rel}} = \begin{vmatrix} \hat{\mathbf{i}} & \hat{\mathbf{j}} & \hat{\mathbf{k}} \\ -0.4 & 0.3 & -1.0 \\ -150 & -400 & 200 \end{vmatrix} = -340\hat{\mathbf{i}} + 230\hat{\mathbf{j}} + 205\hat{\mathbf{k}} \quad (8)$$

$$\boldsymbol{\Omega} \times (\boldsymbol{\Omega} \times \mathbf{r}_{\text{rel}}) = \begin{vmatrix} \hat{\mathbf{i}} & \hat{\mathbf{j}} & \hat{\mathbf{k}} \\ 0.6 & -0.4 & 1.0 \\ 320 & -270 & -300 \end{vmatrix} = 390\hat{\mathbf{i}} + 500\hat{\mathbf{j}} - 34\hat{\mathbf{k}} \quad (9)$$

$$2\boldsymbol{\Omega} \times \mathbf{v}_{\text{rel}} = 2 \begin{vmatrix} \hat{\mathbf{i}} & \hat{\mathbf{j}} & \hat{\mathbf{k}} \\ 0.6 & -0.4 & 1.0 \\ -53.826 & -28.115 & 47.300 \end{vmatrix} = 2(9.151\hat{\mathbf{i}} - 82.206\hat{\mathbf{j}} - 38.399\hat{\mathbf{k}}) \quad (10)$$

$$\begin{aligned}
\mathbf{a}_{\text{rel}} &= 7.5\hat{\mathbf{i}} - 8.5\hat{\mathbf{j}} + 6.0\hat{\mathbf{k}} \\
&= 7.5(0.57735\hat{\mathbf{i}} + 0.57735\hat{\mathbf{j}} + 0.57735\hat{\mathbf{k}}) \\
&\quad - 8.5(-0.74296\hat{\mathbf{i}} + 0.66475\hat{\mathbf{j}} + 0.078206\hat{\mathbf{k}}) \\
&\quad + 6.0(-0.33864\hat{\mathbf{i}} - 0.47410\hat{\mathbf{j}} + 0.81274\hat{\mathbf{k}})
\end{aligned}$$

$$\mathbf{a}_{\text{rel}} = 8.6134\hat{\mathbf{i}} - 4.1649\hat{\mathbf{j}} + 8.5418\hat{\mathbf{k}} \quad (11)$$

Substituting (7), (8), (9), (10) and (11) into (6) yields

$$\begin{aligned}
\mathbf{a} &= (25\hat{\mathbf{i}} + 40\hat{\mathbf{j}} - 15\hat{\mathbf{k}}) + (-340\hat{\mathbf{i}} + 230\hat{\mathbf{j}} + 205\hat{\mathbf{k}}) + (390\hat{\mathbf{i}} + 500\hat{\mathbf{j}} - 34\hat{\mathbf{k}}) \\
&\quad + [2(9.151\hat{\mathbf{i}} - 82.206\hat{\mathbf{j}} - 38.399\hat{\mathbf{k}})] + (8.6134\hat{\mathbf{i}} - 4.1649\hat{\mathbf{j}} + 8.5418\hat{\mathbf{k}})
\end{aligned}$$

$$\begin{aligned}\mathbf{a} &= 102\hat{\mathbf{i}} + 601.42\hat{\mathbf{j}} + 87.743\hat{\mathbf{k}} \\ &= \underline{616.29(0.16551\hat{\mathbf{i}} + 0.97588\hat{\mathbf{j}} + 0.14327\hat{\mathbf{k}})} \left(\text{m/s}^2\right)\end{aligned}$$

**Problem 1.4** From Example 2.8, we have

$$\ddot{\mathbf{F}} = \ddot{\boldsymbol{\omega}} \times \mathbf{F} + 2\dot{\boldsymbol{\omega}} \times (\boldsymbol{\omega} \times \mathbf{F}) + \boldsymbol{\omega} \times [\dot{\boldsymbol{\omega}} \times \mathbf{F} + \boldsymbol{\omega} \times (\boldsymbol{\omega} \times \mathbf{F})]$$

Substituting the given values for the quantities on the right hand side,

$$\begin{aligned}\ddot{\boldsymbol{\omega}} \times \mathbf{F} &= \mathbf{0} \times 10\hat{\mathbf{i}} = \mathbf{0} \\ 2\dot{\boldsymbol{\omega}} \times (\boldsymbol{\omega} \times \mathbf{F}) &= 2(-2\hat{\mathbf{k}}) \times [(3\hat{\mathbf{k}}) \times (10\hat{\mathbf{i}})] = 2(-2\hat{\mathbf{k}}) \times (30\hat{\mathbf{j}}) = 120\hat{\mathbf{i}} \\ \boldsymbol{\omega} \times (\dot{\boldsymbol{\omega}} \times \mathbf{F}) &= (3\hat{\mathbf{k}}) \times [(-2\hat{\mathbf{k}}) \times (10\hat{\mathbf{i}})] = (3\hat{\mathbf{k}}) \times (-20\hat{\mathbf{j}}) = 60\hat{\mathbf{i}} \\ \boldsymbol{\omega} \times [\boldsymbol{\omega} \times (\boldsymbol{\omega} \times \mathbf{F})] &= (3\hat{\mathbf{k}}) \times \{(3\hat{\mathbf{k}}) \times [(3\hat{\mathbf{k}}) \times (10\hat{\mathbf{i}})]\} = (3\hat{\mathbf{k}}) \times [(3\hat{\mathbf{k}}) \times (30\hat{\mathbf{j}})] = (3\hat{\mathbf{k}}) \times (-90\hat{\mathbf{i}}) = -270\hat{\mathbf{j}}\end{aligned}$$

Thus,  $\ddot{\mathbf{F}} = \mathbf{0} + 120\hat{\mathbf{i}} + 60\hat{\mathbf{i}} - 270\hat{\mathbf{j}} = \underline{120\hat{\mathbf{i}} - 270\hat{\mathbf{j}}}$  (N/s<sup>3</sup>).

**Problem 1.5**

$$\hat{\mathbf{i}} = \sin\theta\hat{\mathbf{I}} + \cos\theta\hat{\mathbf{J}} \quad \hat{\mathbf{j}} = -\cos\theta\hat{\mathbf{I}} + \sin\theta\hat{\mathbf{J}} \quad \hat{\mathbf{k}} = \hat{\mathbf{K}} \quad (1)$$

*Velocity analysis*

The absolute velocity of the airplane is

$$\mathbf{v} = v\hat{\mathbf{i}} \quad (2)$$

The absolute velocity of the origin of the moving frame is

$$\mathbf{v}_o = \mathbf{0} \quad (3)$$

The position of the airplane relative to the moving frame is

$$\mathbf{r}_{\text{rel}} = \frac{h}{\cos\theta}\hat{\mathbf{i}} = \frac{h}{\cos\theta}(\sin\theta\hat{\mathbf{I}} + \cos\theta\hat{\mathbf{J}}) = h\frac{\sin\theta}{\cos\theta}\hat{\mathbf{I}} + h\hat{\mathbf{J}} \quad (4)$$

The angular velocity of the moving frame is

$$\boldsymbol{\Omega} = -\dot{\theta}\hat{\mathbf{K}} \quad (5)$$

The velocity of the airplane relative to the moving frame is, making use of (1)

$$\mathbf{v}_{\text{rel}} = v_{\text{rel}}\hat{\mathbf{i}} = v_{\text{rel}}(\sin\theta\hat{\mathbf{I}} + \cos\theta\hat{\mathbf{J}}) = v_{\text{rel}}\sin\theta\hat{\mathbf{I}} + v_{\text{rel}}\cos\theta\hat{\mathbf{J}} \quad (6)$$

According to Equation 1.38,  $\mathbf{v} = \mathbf{v}_o + \boldsymbol{\Omega} \times \mathbf{r}_{\text{rel}} + \mathbf{v}_{\text{rel}}$ . Substituting (2), (3), (4), (5) and (6) yields

$$v\hat{\mathbf{i}} = \mathbf{0} + (-\dot{\theta}\hat{\mathbf{K}}) \times \left(h\frac{\sin\theta}{\cos\theta}\hat{\mathbf{I}} + h\hat{\mathbf{J}}\right) + (v_{\text{rel}}\sin\theta\hat{\mathbf{I}} + v_{\text{rel}}\cos\theta\hat{\mathbf{J}})$$

or

$$v\hat{\mathbf{I}} = \mathbf{0} + \left[ (h\dot{\theta})\hat{\mathbf{I}} - \left( h\dot{\theta} \frac{\sin\theta}{\cos\theta} \right) \hat{\mathbf{J}} \right] + (v_{\text{rel}} \sin\theta \hat{\mathbf{I}} + v_{\text{rel}} \cos\theta \hat{\mathbf{J}})$$

Collecting terms,

$$v\hat{\mathbf{I}} = (h\dot{\theta} + v_{\text{rel}} \sin\theta) \hat{\mathbf{I}} + \left( v_{\text{rel}} \cos\theta - h\dot{\theta} \frac{\sin\theta}{\cos\theta} \right) \hat{\mathbf{J}}$$

Equate the  $\hat{\mathbf{I}}$  and  $\hat{\mathbf{J}}$  components on each side to obtain

$$\begin{aligned} h\dot{\theta} + v_{\text{rel}} \sin\theta &= v \\ -h\dot{\theta} \frac{\sin\theta}{\cos\theta} + v_{\text{rel}} \cos\theta &= 0 \end{aligned}$$

Solving these two equations for  $\dot{\theta}$  and  $v_{\text{rel}}$  yields

$$\dot{\theta} = \frac{v}{h} \cos^2\theta \quad (7)$$

$$v_{\text{rel}} = v \sin\theta \quad (8)$$

### Acceleration analysis

The absolute acceleration of the airplane, the absolute acceleration of the origin of the moving frame, and the angular acceleration of the moving frame are, respectively,

$$\mathbf{a} = \mathbf{0} \quad \mathbf{a}_o = \mathbf{0} \quad \dot{\boldsymbol{\Omega}} = -\ddot{\theta} \hat{\mathbf{K}} \quad (9)$$

The acceleration of the airplane relative to the moving frame is, making use of (1),

$$\mathbf{a}_{\text{rel}} = a_{\text{rel}} \hat{\mathbf{i}} = a_{\text{rel}} (\sin\theta \hat{\mathbf{I}} + \cos\theta \hat{\mathbf{J}}) = a_{\text{rel}} \sin\theta \hat{\mathbf{I}} + a_{\text{rel}} \cos\theta \hat{\mathbf{J}} \quad (10)$$

Substituting (7) into (5), the angular velocity of the moving frame becomes

$$\boldsymbol{\Omega} = -\dot{\theta} \hat{\mathbf{K}} = -\frac{v}{h} \cos^2\theta \hat{\mathbf{K}} \quad (11)$$

Substituting (8) into (6) yields

$$\mathbf{v}_{\text{rel}} = v_{\text{rel}} \hat{\mathbf{i}} = v \sin\theta (\sin\theta \hat{\mathbf{I}} + \cos\theta \hat{\mathbf{J}}) = v \sin^2\theta \hat{\mathbf{I}} + v \sin\theta \cos\theta \hat{\mathbf{J}} \quad (12)$$

From (4) and (9) we find

$$\dot{\boldsymbol{\Omega}} \times \mathbf{r}_{\text{rel}} = (-\ddot{\theta} \hat{\mathbf{K}}) \times \left( h \frac{\sin\theta}{\cos\theta} \hat{\mathbf{I}} + h \hat{\mathbf{J}} \right) = h\ddot{\theta} \hat{\mathbf{I}} - h\ddot{\theta} \frac{\sin\theta}{\cos\theta} \hat{\mathbf{J}} \quad (13)$$

Using (5) and (7) we get

$$\boldsymbol{\Omega} \times \mathbf{r}_{\text{rel}} = h\dot{\theta} \hat{\mathbf{I}} - h\dot{\theta} \frac{\sin\theta}{\cos\theta} \hat{\mathbf{J}} = h \left( \frac{v}{h} \cos^2\theta \right) \hat{\mathbf{I}} - h \left( \frac{v}{h} \cos^2\theta \right) \frac{\sin\theta}{\cos\theta} \hat{\mathbf{J}} = v \cos^2\theta \hat{\mathbf{I}} - v \sin\theta \cos\theta \hat{\mathbf{J}} \quad (14)$$

From (11) and (14) we have

$$\boldsymbol{\Omega} \times (\boldsymbol{\Omega} \times \mathbf{r}_{\text{rel}}) = \begin{vmatrix} \hat{\mathbf{i}} & \hat{\mathbf{j}} & \hat{\mathbf{k}} \\ 0 & 0 & -\frac{v}{h} \cos^2 \theta \\ v \cos^2 \theta & -v \sin \theta \cos \theta & 0 \end{vmatrix} = -\frac{v^2}{h} \sin \theta \cos^3 \theta \hat{\mathbf{i}} - \frac{v^2}{h} \cos^4 \theta \hat{\mathbf{j}} \quad (15)$$

From (11) and (12),

$$2\boldsymbol{\Omega} \times \mathbf{v}_{\text{rel}} = 2 \begin{vmatrix} \hat{\mathbf{i}} & \hat{\mathbf{j}} & \hat{\mathbf{k}} \\ 0 & 0 & -\frac{v}{h} \cos^2 \theta \\ v \sin^2 \theta & v \sin \theta \cos \theta & 0 \end{vmatrix} = 2 \frac{v^2}{h} \sin \theta \cos^3 \theta \hat{\mathbf{i}} - 2 \frac{v^2}{h} \sin^2 \theta \cos^2 \theta \hat{\mathbf{j}} \quad (16)$$

According to Equation 1.42,  $\mathbf{a} = \mathbf{a}_o + \dot{\boldsymbol{\Omega}} \times \mathbf{r}_{\text{rel}} + \boldsymbol{\Omega} \times (\boldsymbol{\Omega} \times \mathbf{r}_{\text{rel}}) + 2\boldsymbol{\Omega} \times \mathbf{v}_{\text{rel}} + \mathbf{a}_{\text{rel}}$ . Substituting (9), (10), (13), (15) and (16) yields

$$\begin{aligned} \mathbf{0} &= \mathbf{0} + \left( h\ddot{\theta} \hat{\mathbf{i}} - h\ddot{\theta} \frac{\sin \theta}{\cos \theta} \hat{\mathbf{j}} \right) + \left( -\frac{v^2}{h} \sin \theta \cos^3 \theta \hat{\mathbf{i}} - \frac{v^2}{h} \cos^4 \theta \hat{\mathbf{j}} \right) \\ &+ \left( 2 \frac{v^2}{h} \sin \theta \cos^3 \theta \hat{\mathbf{i}} - 2 \frac{v^2}{h} \sin^2 \theta \cos^2 \theta \hat{\mathbf{j}} \right) + \left( a_{\text{rel}} \sin \theta \hat{\mathbf{i}} + a_{\text{rel}} \cos \theta \hat{\mathbf{j}} \right) \end{aligned}$$

Collecting terms

$$\begin{aligned} \mathbf{0} &= \left( h\ddot{\theta} - \frac{v^2}{h} \sin \theta \cos^3 \theta + 2 \frac{v^2}{h} \sin \theta \cos^3 \theta + a_{\text{rel}} \sin \theta \right) \hat{\mathbf{i}} \\ &+ \left( -h\ddot{\theta} \frac{\sin \theta}{\cos \theta} - \frac{v^2}{h} \cos^4 \theta - 2 \frac{v^2}{h} \sin^2 \theta \cos^2 \theta + a_{\text{rel}} \cos \theta \right) \hat{\mathbf{j}} \end{aligned}$$

or

$$\mathbf{0} = \left( h\ddot{\theta} + \frac{v^2}{h} \sin \theta \cos^3 \theta + a_{\text{rel}} \sin \theta \right) \hat{\mathbf{i}} + \left( -h\ddot{\theta} \frac{\sin \theta}{\cos \theta} - \frac{v^2}{h} \cos^2 \theta (1 + \sin^2 \theta) + a_{\text{rel}} \cos \theta \right) \hat{\mathbf{j}}$$

Equate the  $\hat{\mathbf{i}}$  and  $\hat{\mathbf{j}}$  components on each side to obtain

$$\begin{aligned} h\ddot{\theta} + a_{\text{rel}} \sin \theta &= -\frac{v^2}{h} \sin \theta \cos^3 \theta \\ -h\ddot{\theta} \frac{\sin \theta}{\cos \theta} + a_{\text{rel}} \cos \theta &= \frac{v^2}{h} \cos^2 \theta (1 + \sin^2 \theta) \end{aligned}$$

Solving these two equations for  $\ddot{\theta}$  and  $a_{\text{rel}}$  yields

$$\ddot{\theta} = -2 \frac{v^2}{h^2} \cos^3 \theta \sin \theta \quad a_{\text{rel}} = \frac{v^2}{h} \cos^3 \theta$$

**Problem 1.6** From Equation 2.58b with  $z = 0$  we have

$$\mathbf{a} = -2\Omega \dot{y} \sin \phi \hat{\mathbf{i}} + \Omega^2 R_E \sin \phi \cos \phi \hat{\mathbf{j}} - \left[ \frac{\dot{y}^2}{R_E} + \Omega^2 R_E \cos^2 \phi \right] \hat{\mathbf{k}} \quad (1)$$

where

$$R_E = 6378 \times 10^3 \text{ m}$$

$$\phi = 30^\circ$$

$$\dot{y} = \frac{1000 \times 10^3}{3600} = 27.78 \text{ m/s}$$

$$\Omega = \frac{2\pi}{23.934 \times 3600} = 7.2921 \times 10^{-5} \text{ rad/s}$$

Substituting these numbers into (1), we find

$$\mathbf{a} = -0.0020256\hat{\mathbf{i}} + 0.014686\hat{\mathbf{j}} - 0.025557\hat{\mathbf{k}} \text{ (m/s}^2\text{)}$$

From  $\mathbf{F} = m\mathbf{a}$ , with  $m = 1000 \text{ kg}$ , we obtain the net force on the car,

$$\mathbf{F} = -2.0256\hat{\mathbf{i}} + 14.686\hat{\mathbf{j}} - 25.557\hat{\mathbf{k}} \text{ (N)}$$

$$F_{\text{lateral}} = F_x = -2.0256 \text{ N} = -0.4554 \text{ lb, that is}$$

$$F_{\text{lateral}} = 0.4554 \text{ lb to the west}$$

The normal force  $N$  of the road on the car is given by  $N = F_z + mg$ , so that

$$N = -25.557 + 1000 \times 9.81 = 9784 \text{ N}$$

**Problem 1.7** From Equation 1.61b, with  $z = 0$ ,

$$\mathbf{a} = \Omega^2 R_E \sin l \cos l \hat{\mathbf{j}} - \Omega^2 R_E \cos^2 l \hat{\mathbf{k}}$$

From  $\sum F_y = ma_y$  we get

$$T \sin \theta = m\Omega^2 R_E \sin \phi \cos \phi$$

$$T = \frac{m\Omega^2 R_E \sin \phi \cos \phi}{\sin \theta}$$

From  $\sum F_z = ma_z$  we obtain

$$T \cos \theta - mg = -m\Omega^2 R_E \cos^2 \phi$$

$$\frac{m\Omega^2 R_E \sin \phi \cos \phi}{\sin \theta} \cos \theta - mg = -m\Omega^2 R_E \cos^2 \phi$$

$$\tan \theta = \frac{\Omega^2 R_E \sin \phi \cos \phi}{g - \Omega^2 R_E \cos^2 \phi}$$

Since  $d = L \tan \theta$ , we deduce

$$d = L \frac{\Omega^2 R_E \sin \phi \cos \phi}{g - \Omega^2 R_E \cos^2 \phi}$$

Setting

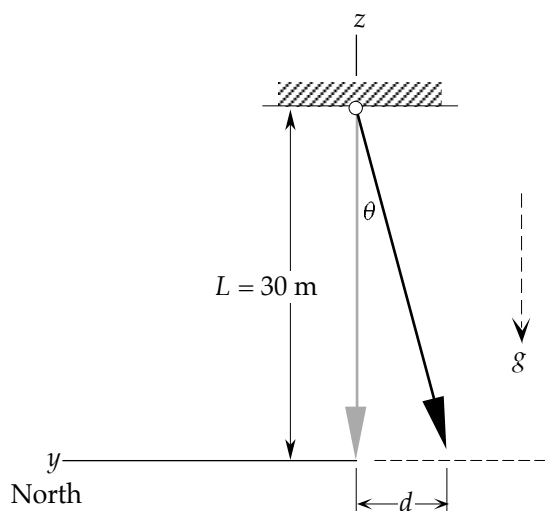



$$L = 30 \text{ m}$$

$$R_E = 6378 \times 1000 = 6.378 \times 10^6 \text{ m}$$

$$\phi = 29^\circ$$

$$g = 9.81 \text{ m/s}^2$$

$$\Omega = \frac{2\pi}{23.9344 \times 3600} = 7.2921 \times 10^{-5} \text{ rad/s}$$

yields

$$d = 44.1 \text{ mm (to the south)}$$

---

**Problem 2.1**

$$\mathbf{r} = 3t^4\hat{\mathbf{I}} + 2t^3\hat{\mathbf{J}} + 9t^2\hat{\mathbf{K}}$$

$$\|\mathbf{r}\| = \sqrt{(3t^4\hat{\mathbf{I}} + 2t^3\hat{\mathbf{J}} + 9t^2\hat{\mathbf{K}}) \cdot (3t^4\hat{\mathbf{I}} + 2t^3\hat{\mathbf{J}} + 9t^2\hat{\mathbf{K}})} = \sqrt{9t^8 + 4t^6 + 81t^4}$$

$$\dot{r} = \frac{d\|\mathbf{r}\|}{dt} = \frac{36t^7 + 12t^5 + 162t^3}{\sqrt{9t^8 + 4t^6 + 81t^4}}$$

At  $t = 2$  sec,

$$\dot{r} = \frac{4608 + 384 + 1296}{\sqrt{2304 + 256 + 1296}} = 101.3 \text{ m/s}$$

$$\dot{\mathbf{r}} = 12t^3\hat{\mathbf{I}} + 6t^2\hat{\mathbf{J}} + 18t\hat{\mathbf{K}}$$

$$\|\dot{\mathbf{r}}\| = \sqrt{(12t^3\hat{\mathbf{I}} + 6t^2\hat{\mathbf{J}} + 18t\hat{\mathbf{K}}) \cdot (12t^3\hat{\mathbf{I}} + 6t^2\hat{\mathbf{J}} + 18t\hat{\mathbf{K}})} = \sqrt{144t^6 + 36t^4 + 324t^2}$$

At  $t = 2$  sec,

$$\|\dot{\mathbf{r}}\| = \sqrt{9216 + 576 + 1296} = 105.3 \text{ m/s}$$

**Problem 2.2**

$$\hat{\mathbf{u}}_r \cdot \hat{\mathbf{u}}_r = 1 \Rightarrow \frac{d}{dt}(\hat{\mathbf{u}}_r \cdot \hat{\mathbf{u}}_r) = 0 \Rightarrow \frac{d\hat{\mathbf{u}}_r}{dt} \cdot \hat{\mathbf{u}}_r + \hat{\mathbf{u}}_r \cdot \frac{d\hat{\mathbf{u}}_r}{dt} = 0 \Rightarrow \hat{\mathbf{u}}_r \cdot \frac{d\hat{\mathbf{u}}_r}{dt} = 0$$

Or,

$$\frac{d\hat{\mathbf{u}}_r}{dt} = \frac{d}{dt} \left( \frac{\mathbf{r}}{r} \right) = \frac{r \frac{d\mathbf{r}}{dt} - \mathbf{r} \frac{dr}{dt}}{r^2} = \frac{r\dot{\mathbf{r}} - r\dot{r}}{r^2}$$

$$\hat{\mathbf{u}}_r \cdot \frac{d\hat{\mathbf{u}}_r}{dt} = \frac{\mathbf{r}}{r} \cdot \frac{r\dot{\mathbf{r}} - r\dot{r}}{r^2} = \frac{\mathbf{r} \cdot \dot{\mathbf{r}}}{r^2} - \frac{r\dot{r}}{r^2}$$

But according to Equation 2.25,  $\mathbf{r} \cdot \dot{\mathbf{r}} = r\dot{r}$ . Hence  $\hat{\mathbf{u}}_r \cdot \frac{d\hat{\mathbf{u}}_r}{dt} = 0$

**Problem 2.3** Both particles rotate with a constant angular velocity around the center of mass  $c.m.$ , which lies midway along the line joining the two masses. Let  $\hat{\mathbf{u}}$  be the unit vector drawn from one of the masses to  $c.m.$ , which is the origin of an inertial frame. The only force on  $m$  is that of mutual gravitational attraction,

$$\mathbf{F}_g = G \frac{m^2}{d^2} \hat{\mathbf{u}}$$

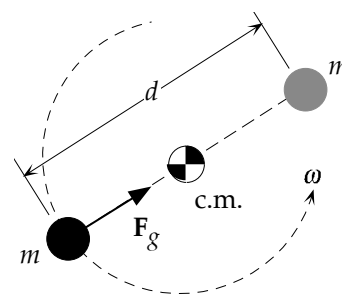

The absolute acceleration of  $m$  is normal to its circular path around  $c.m.$ ,

$$\mathbf{a} = \omega^2 \frac{d}{2} \hat{\mathbf{u}}$$

From Newton's second law,  $\mathbf{F}_g = m\mathbf{a}$ , so that  $G \frac{m^2}{d^2} \hat{\mathbf{u}} = m\omega^2 \frac{d}{2} \hat{\mathbf{u}}$ , or

$$\omega = \sqrt{\frac{2Gm}{d^3}}$$

**Problem 2.4** The center of mass of the three equal masses lies at the centroid of the equilateral triangle, whose altitude  $h$  is given by  $h = d_0 \sin 60^\circ$ . The distance  $r$  of each mass from the center of mass is, therefore

$$r = \frac{2}{3}h = \frac{2}{3}d_0 \sin 60^\circ$$

Relative to an inertial frame with the center of mass as its origin, the acceleration of each particle is

$$a = \omega_o^2 r = \frac{2}{3}\omega_o^2 d_0 \sin 60^\circ$$

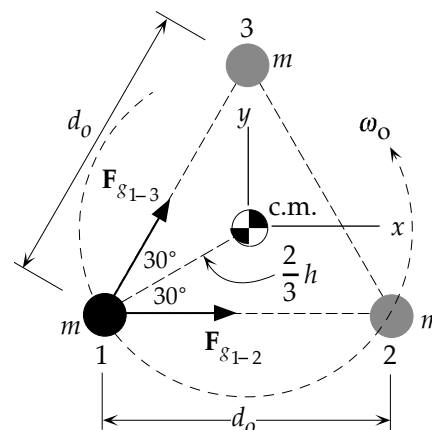

and this acceleration is directed toward the center of mass. The net force on each particle is the vector sum of the gravitational force of attraction of its two neighbors. This net force is directed towards the center of mass, so that its magnitude, focusing on particle 1 in the figure, is

$$F_{net} = F_{g_{1-2}} \cos 30^\circ + F_{g_{1-3}} \cos 30^\circ = G \frac{m \cdot m}{d_o^2} \cos 30^\circ + G \frac{m \cdot m}{d_o^2} \cos 30^\circ = 2 \frac{Gm^2}{d_o^2} \cos 30^\circ$$

Setting  $F_{net} = ma$ , we get

$$\begin{aligned} 2 \frac{Gm^2}{d_o^2} \cos 30^\circ &= m \frac{2}{3} \omega_o^2 d_o \sin 60^\circ \\ \omega_o^2 &= \frac{3Gm \cos 30^\circ}{d_o^3 \sin 60^\circ} = \frac{3Gm}{d_o^3} \\ \omega_o &= \sqrt{\frac{3Gm}{d_o^3}} \end{aligned}$$

### Problem 2.5

$$(a) \quad v = \sqrt{\frac{\mu}{r}} = \sqrt{\frac{398,600}{6378 + 350}} = 7.697 \text{ km/s}$$

$$(b) \quad T = \frac{2\pi}{\sqrt{\mu}} r^{\frac{3}{2}} = \frac{2\pi}{\sqrt{398,600}} (6378 + 350)^{\frac{3}{2}} = 5492 \text{ sec} = 91 \text{ min } 32 \text{ s}$$

**Problem 2.6** The mass of the moon is  $7.348 \times 10^{22}$  kg. Therefore, for a satellite orbiting the moon,

$$\mu = Gm_{\text{moon}} = \left( 6.67259 \times 10^{-20} \frac{\text{km}^3}{\text{kg} \cdot \text{s}^2} \right) (7.348 \times 10^{22} \text{ kg}) = 4903 \frac{\text{km}^3}{\text{s}^2}$$

The radius of the moon is 1738 km. Hence

$$v = \sqrt{\frac{\mu}{r}} = \sqrt{\frac{4903}{1738 + 80}} = 1.642 \text{ km/s}$$

$$T = \frac{2\pi}{\sqrt{\mu}} r^{\frac{3}{2}} = \frac{2\pi}{\sqrt{4903}} (1738 + 80)^{\frac{3}{2}} = 6956 \text{ sec} = 1 \text{ hr } 56 \text{ min}$$

**Problem 2.7** The time between successive crossings of the equator equals the period of the orbit. That is

$$\frac{d}{\Omega_{\text{Earth}} R_{\text{Earth}}} = \frac{2\pi}{\sqrt{\mu}} (R_{\text{Earth}} + z)^{3/2}$$

where  $d = 3000$  km is the distance between ground tracks,  $z$  is the altitude of the orbit,  $R_{\text{Earth}} = 6378$  km and  $\Omega_{\text{Earth}} = 2\pi/(23.934 \cdot 3600) = 7.2921 \times 10^{-5}$  rad/s. Thus

$$\frac{3000}{(7.2921 \times 10^{-5})(6378)} = \frac{2\pi}{\sqrt{398\,600}} (6378 + z)^{3/2}$$

so that

$$z = 1440.7 \text{ km}$$

**Problem 2.8** From Example 2.3 we know that  $v_{\text{GEO}} = 3.0747$  km/s. From Equation 2.82 we know that

$$v_{\text{esc}} = \sqrt{2} v_{\text{circular}}. \text{ Hence } \Delta v = (\sqrt{2} - 1) v_{\text{GEO}} = 0.41421 \cdot 3.0747 = \underline{1.2736 \text{ km/s}}.$$

**Problem 2.9**

$$\mu_{\text{sun}} = 1.3271 \times 10^{11} \text{ km}^3/\text{s}^2$$

$$r_{\text{earth}} = 149.6 \times 10^6 \text{ km}$$

$$v_{\text{earth}} = \sqrt{\frac{\mu_{\text{sun}}}{r_{\text{earth}}}} = \sqrt{\frac{1.3271 \times 10^{11}}{149.6 \times 10^6}} = 29.784 \text{ km/s}$$

$$v_{\text{esc}} = \sqrt{2} \cdot 29.784 = 42.121 \text{ km/s}$$

$$v_{\text{relative}} = 42.121 - 29.784 = \underline{12.337 \text{ km/s}}$$

**Problem 2.10**

$$\frac{A}{T/3} = \frac{\pi ab}{T}$$

$$A = \frac{\pi ab}{3} = \underline{1.0472 ab}$$

**Problem 2.11**

$$v_r = \frac{\mu}{h} e \sin \theta$$

$$v_{\perp} = \frac{h}{r} = \frac{h}{\frac{h^2}{\mu} \frac{1}{1 + e \cos \theta}}$$

$$v = \sqrt{v_r^2 + v_{\perp}^2}$$

$$= \frac{\mu}{h} \sqrt{e^2 (\cos^2 \theta + \sin^2 \theta) + 2e \cos \theta + 1}$$

$$v = \frac{\mu}{h} \sqrt{e^2 + 2e \cos \theta + 1}$$

**Problem 2.12** For the ellipse, according to Problem 2.11,

$$v_{\text{ellipse}}^2 = \frac{\mu^2}{h^2} (e^2 + 2e \cos \theta + 1)$$

For the circle, at the point of intersection with the ellipse,

$$v_{\text{circle}}^2 = \frac{\mu}{r} = \frac{\mu}{\frac{h^2}{\mu} \frac{1}{1 + e \cos \theta}} = \frac{\mu^2}{h^2} (1 + e \cos \theta)$$

Setting  $v_{\text{circle}}^2 = v_{\text{ellipse}}^2$ ,

$$\frac{\mu^2}{h^2} (1 + e \cos \theta) = \frac{\mu^2}{h^2} (e^2 + 2e \cos \theta + 1)$$

yields  $e \cos \theta = -e^2$ , or  $\theta = \cos^{-1}(-e)$ .

**Problem 2.13** From Equation 3.42

$$\tan \gamma = \frac{e \sin \theta}{1 + e \cos \theta}$$

From Problem 2.12  $\theta = \cos^{-1}(-e)$ . Hence

$$\tan \gamma = \frac{e \sin[\cos^{-1}(-e)]}{1 - e^2}$$

But  $\sin[\cos^{-1}(-e)] = \sqrt{1 - e^2}$ . Therefore,

$$\tan \gamma = \frac{e \sqrt{1 - e^2}}{1 - e^2} = \frac{e}{\sqrt{1 - e^2}}$$

**Problem 2.14**

(a)

$$e = \frac{r_{\text{apogee}} - r_{\text{perigee}}}{r_{\text{apogee}} + r_{\text{perigee}}} = \frac{70\,000 - 7\,000}{70\,000 + 7\,000} = \underline{0.81818} \text{ (ellipse)}$$

(b)

$$a = \frac{r_{\text{apogee}} + r_{\text{perigee}}}{2} = \frac{77\,000}{2} = \underline{38\,500 \text{ km}}$$

(c)

$$T = \frac{2\pi}{\sqrt{\mu}} a^{3/2} = \frac{2\pi}{\sqrt{398\,600}} (38\,500)^{3/2} = \underline{75\,180 \text{ s}} \text{ (20.88 h)}$$

(d)

$$\varepsilon = -\frac{\mu}{2a} = -\frac{398\,600}{2 \cdot 38\,500} = \underline{-5.1766 \text{ km}^2/\text{s}^2}$$

(e) From Equation 3.62,

$$6378 + 1000 = \frac{38\,500(1 - 0.81818^2)}{1 + 0.81818 \cos \theta}$$

$$\cos \theta = 0.88615 \Rightarrow \underline{\theta = 27.607^\circ}$$

(f) From Equation 3.40

$$h = \sqrt{\mu(1+e)r_{\text{perigee}}} = \sqrt{398\,600 \cdot (1+0.81818) \cdot 7000} = \underline{71\,226 \text{ km}^2/\text{s}}$$

Then

$$v_{\perp} = \frac{h}{r} = \frac{71\,226}{7378} = \underline{9.6538 \text{ km/s}}$$

$$v_r = \frac{\mu}{h} e \sin \theta = \frac{398\,600}{71\,226} \cdot 0.81818 \cdot \sin 27.607^\circ = \underline{2.1218 \text{ km/s}}$$

(g)

$$v_{\text{perigee}} = \frac{h}{r_{\text{perigee}}} = \frac{71\,226}{7000} = \underline{10.175 \text{ km/s}}$$

$$v_{\text{apogee}} = \frac{h}{r_{\text{apogee}}} = \frac{71\,226}{70\,000} = \underline{1.0175 \text{ km/s}}$$

**Problem 2.15**

$$r_{\text{perigee}} = 6378 + 250 = 6628 \text{ km}$$

$$r_{\text{apogee}} = 6378 + 300 = 6678 \text{ km}$$

$$a = \frac{r_{\text{perigee}} + r_{\text{apogee}}}{2} = \frac{6628 + 6678}{2} = 6653 \text{ km}$$

$$T = \frac{2\pi}{\sqrt{\mu}} a^{3/2} = \frac{2\pi}{\sqrt{398\,600}} \cdot 6653^{3/2} = 5400.5 \text{ s (90.009 m)}$$

$$t_{\text{perigee to apogee}} = \frac{T}{2} = \underline{45.005 \text{ m}}$$

**Problem 2.16**

(a)

$$e = \frac{r_{\text{apogee}} - r_{\text{perigee}}}{r_{\text{apogee}} + r_{\text{perigee}}} = \frac{(6378 + 1600) - (6378 + 600)}{(6378 + 1600) + (6378 + 600)} = \underline{0.066863}$$

(b)

$$h = \sqrt{\mu(1+e)r_{\text{perigee}}} = \sqrt{398\,600 \cdot (1+0.066863) \cdot (6378 + 600)} = \underline{54\,474 \text{ km}^2/\text{s}}$$

$$v_{\text{perigee}} = \frac{h}{r_{\text{perigee}}} = \frac{54\,474}{6378 + 600} = \underline{7.8065 \text{ km/s}}$$

$$v_{\text{apogee}} = \frac{h}{r_{\text{apogee}}} = \frac{54\,474}{6378 + 1600} = \underline{6.8280 \text{ km/s}}$$

(c)

$$T = \frac{2\pi}{\mu^2} \left( \frac{h}{\sqrt{1-e^2}} \right)^3 = \frac{2\pi}{398\,600^2} \left( \frac{54\,474}{\sqrt{1-0.066863^2}} \right)^3 = 6435.6 \text{ s} = \underline{107.26 \text{ m}}$$

**Problem 2.17**

$$h = r_{\text{perigee}} v_{\text{perigee}} = (6378 + 1270) \cdot 9 = 68\,832 \text{ km}^2/\text{s}$$

$$r_{\text{perigee}} = \frac{h^2}{\mu^2} \frac{1}{1+e}$$

$$6378 + 1270 = \frac{68\,832^2}{398\,600^2} \frac{1}{1+e} \Rightarrow e = 0.55416$$

$$\tan \gamma = \frac{e \sin \theta}{1 + e \cos \theta} = \frac{0.55416 \cdot \sin 100^\circ}{1 + 0.55416 \cos 100^\circ} = 0.60385 \Rightarrow \underline{\gamma = 31.13^\circ}$$

$$z + R_{\text{earth}} = \frac{h^2}{\mu} \frac{1}{1 + e \cos \theta}$$

$$z + 6378 = \frac{68\,832^2}{398\,600} \frac{1}{1 + 0.55416 \cos 100^\circ} \Rightarrow \underline{z = 6773.8 \text{ km}}$$

$$h = r_{\text{perigee}} v_{\text{perigee}} = (6378 + 1270) \cdot 9 = 68\,832 \text{ km}^2/\text{s}$$

$$r_{\text{perigee}} = \frac{h^2}{\mu^2} \frac{1}{1+e}$$

$$6378 + 1270 = \frac{68\,832^2}{398\,600^2} \frac{1}{1+e} \Rightarrow e = 0.55416$$

$$\tan \gamma = \frac{e \sin \theta}{1 + e \cos \theta} = \frac{0.55416 \cdot \sin 100^\circ}{1 + 0.55416 \cos 100^\circ} = 0.60385 \Rightarrow \underline{\gamma = 31.13^\circ}$$

$$z + R_{\text{earth}} = \frac{h^2}{\mu} \frac{1}{1 + e \cos \theta}$$

$$z + 6378 = \frac{68\,832^2}{398\,600} \frac{1}{1 + 0.55416 \cos 100^\circ} \Rightarrow \underline{z = 6773.8 \text{ km}}$$

**Problem 2.18**

$$v_r = v \sin \gamma = 9.2 \cdot \sin 10^\circ = 1.5976 \text{ km/s}$$

$$v_\perp = v \cos \gamma = 9.2 \cdot \cos 10^\circ = 9.0602 \text{ km/s}$$

$$\therefore h = r v_\perp = (6378 + 640) \cdot 9.0602 = 63\,585 \text{ km}^2/\text{s}$$

$$r = \frac{h^2}{\mu} \frac{1}{1 + e \cos \theta}$$

$$6378 + 640 = \frac{63\,585^2}{398\,600} \frac{1}{1 + e \cos \theta}$$

$$e \cos \theta = 0.445\,29$$

$$v_r = \frac{\mu}{h} e \sin \theta$$

$$1.5976 = \frac{398\,600}{63\,585} e \sin \theta$$

$$e \sin \theta = 0.254\,84$$

$$\tan \theta = \frac{\sin \theta}{\cos \theta} = \frac{0.254\,84}{0.445\,29} = 0.572\,31 \Rightarrow \underline{\theta = 29.783^\circ}$$

$$e \sin 29.783^\circ = 0.254\,84 \Rightarrow e = 0.51306$$

$$T = \frac{2\pi}{\mu^2} \left( \frac{h}{\sqrt{1-e^2}} \right)^3 = \frac{2\pi}{398\,600^2} \left( \frac{63\,585}{\sqrt{1-0.51306^2}} \right)^3 = 16\,075 \text{ s} = \underline{4.4654 \text{ h}}$$

**Problem 2.19**

$$a = \frac{r_{\text{perigee}} + r_{\text{apogee}}}{2} = \frac{(6378 + 250) + (6378 + 42\,000)}{2} = 27\,503 \text{ km}$$

$$T = \frac{2\pi}{\sqrt{\mu}} a^{3/2} = \frac{2\pi}{\sqrt{398\,600}} 27\,503^{3/2} = 45\,392 \text{ s} = \underline{12.61 \text{ h}}$$

$$e = \frac{r_{\text{apogee}} - r_{\text{perigee}}}{r_{\text{apogee}} + r_{\text{perigee}}} = \frac{(6378 + 42\,000) - (6378 + 250)}{(6378 + 42\,000) + (6378 + 250)} = \underline{0.75901}$$

$$h = \sqrt{\mu(1+e)r_{\text{perigee}}} = \sqrt{398\,600 \cdot (1 + 0.75901) \cdot (6378 + 250)} = 68\,170 \text{ km}^2/\text{s}$$

$$v_{\text{perigee}} = \frac{h}{r_{\text{perigee}}} = \frac{68\,170}{6378 + 250} = \underline{10.285 \text{ km/s}}$$

**Problem 2.20**

$$h = r_{\text{perigee}} v_{\text{perigee}} = (6378 + 640) \cdot 8 = 56\,144 \text{ km}^2/\text{s}$$

$$r_{\text{perigee}} = \frac{h^2}{\mu} \frac{1}{1+e}$$

$$7018 = \frac{56\,144^2}{398\,600} \frac{1}{1+e} \Rightarrow e = 0.126\,82$$

$$r_{\text{apogee}} = \frac{h^2}{\mu} \frac{1}{1-e} = \frac{56\,144^2}{398\,600} \frac{1}{1-0.126\,82} = 9056.6 \text{ km}$$

$$z_{\text{apogee}} = 9056.6 - 6378 = \underline{2678.6 \text{ km}}$$

$$a = \frac{r_{\text{perigee}} + r_{\text{apogee}}}{2} = \frac{(7018) + (9056.6)}{2} = 8037.3 \text{ km}$$

$$T = \frac{2\pi}{\sqrt{\mu}} a^{3/2} = \frac{2\pi}{\sqrt{398\,600}} 8037.3^{3/2} = 7171 \text{ s} = \underline{1.992 \text{ h}}$$

**Problem 2.21**

$$T = \frac{2\pi}{\sqrt{\mu}} a^{3/2}$$

$$2 \cdot 3600 = \frac{2\pi}{\sqrt{398\,600}} a^{3/2} \Rightarrow \underline{a = 8059 \text{ km}}$$

Using the energy equation

$$\frac{v_{\text{perigee}}^2}{2} - \frac{\mu}{r_{\text{perigee}}} = -\frac{\mu}{2a}$$

$$\frac{8^2}{2} - \frac{398\,600}{r_{\text{perigee}}} = -\frac{398\,600}{2 \cdot 8059} \Rightarrow r_{\text{perigee}} = 7026.2 \text{ km}$$

$$z_{\text{perigee}} = 7026.2 - 6378 = \underline{648.25 \text{ km}}$$



**Problem 2.22**

$$T = \frac{2\pi}{\sqrt{\mu}} a^{3/2}$$

$$90 \cdot 60 = \frac{2\pi}{\sqrt{\mu}} a^{3/2} \Rightarrow a = 6652.6 \text{ km}$$

$$r_{\text{perigee}} + r_{\text{apogee}} = 2a$$

$$(6378 + 150) + r_{\text{apogee}} = 2 \cdot 6652.6 \Rightarrow r_{\text{apogee}} = 6777.1 \text{ km}$$

$$e = \frac{r_{\text{apogee}} - r_{\text{perigee}}}{r_{\text{apogee}} + r_{\text{perigee}}} = \frac{6777.1 - 6528}{6777.1 + 6528} = \underline{0.018723}$$

**Problem 2.23**

(a)

$$v_{\text{esc}} = \sqrt{2 \frac{\mu}{r}} = \sqrt{2 \frac{398\,600}{6378 + 300}} = 10.926 \text{ km/s}$$

$$v_{\infty} = \sqrt{v_{\text{perigee}}^2 - v_{\text{esc}}^2} = \sqrt{15^2 - 10.926^2} = \underline{10.277 \text{ km/s}}$$

(b)

$$h = r_{\text{perigee}} v_{\text{perigee}} = 6678 \cdot 15 = 100\,170 \text{ km}^2/\text{s}$$

$$r_{\text{perigee}} = \frac{h^2}{\mu} \frac{1}{1+e}$$

$$6678 = \frac{100\,170^2}{398\,600} \frac{1}{1+e} \Rightarrow e = 2.7696$$

$$r = \frac{h^2}{\mu} \frac{1}{1+e \cos \theta} = \frac{100\,170^2}{398\,600} \frac{1}{1+2.7696 \cos 100^\circ} = \underline{48\,497 \text{ km/s}}$$

(c)

$$v_r = \frac{\mu}{h} e \sin \theta = \frac{398\,600}{100\,170} \cdot 2.7696 \cdot \sin 100^\circ = \underline{10.853 \text{ km/s}}$$

$$v_{\perp} = \frac{h}{r} = \frac{100\,170}{48\,497} = \underline{2.0655 \text{ km/s}}$$

**Problem 2.24**

(a) From Equation 3.47

$$\varepsilon = \frac{v^2}{2} - \frac{\mu}{r} = \frac{2.23^2}{2} - \frac{398\,600}{402\,000} = 1.4949 \text{ km}^2/\text{s}^2$$

From Equation 3.50

$$h^2 = -\frac{1}{2} \frac{\mu^2}{\varepsilon} (1 - e^2) = -\frac{1}{2} \frac{398\,600^2}{1.4949} (1 - e^2)$$

$$h^2 = (5.3141e^2 - 1) \times 10^{10}$$

From the orbit equation

$$h^2 = \mu r(1 + e \cos \theta) = 398\,600 \cdot 402\,000 \cdot (1 + e \cos 150^\circ)$$

$$h^2 = (16.024 - 13.877e) \times 10^{10}$$

Equating the two expressions for  $h^2$ ,

$$(5.3141e^2 - 1) \times 10^{10} = (16.024 - 13.877e) \times 10^{10}$$

yields

$$e^2 + 22.6113e - 4.0153 = 0$$

which has the positive root

$$e = \underline{1.086}$$

(b) Using this value of the eccentricity we find

$$h^2 = (16.024 - 13.877 \cdot 1.086) \times 10^{10} = 9.5334 \times 10^9 \text{ km}^4/\text{s}^2$$

so that

$$r_{\text{perigee}} = \frac{h^2}{\mu} \frac{1}{1+e} = \frac{9.5334 \times 10^9}{398\,600} \frac{1}{1+1.086} = 11\,466 \text{ km}$$

$$z_{\text{perigee}} = 11\,466 - 6378 = \underline{5087.6 \text{ km}}$$

(c)

$$v_{\text{perigee}} = \frac{h}{r_{\text{perigee}}} = \frac{\sqrt{9.5334 \times 10^9}}{11\,466} = \underline{8.5158 \text{ km/s}}$$

**Problem 2.25** From the energy equation

$$v_\infty^2 + v_{\text{esc}}^2 = v^2$$

$$v_\infty^2 + \frac{2\mu}{r} = (1.1v_\infty)^2$$

$$r = 9.5238 \frac{\mu}{v_\infty^2}$$

Substituting Equation 3.105

$$r = 9.5238 \frac{\mu}{\left(\frac{\mu}{h} \sqrt{e^2 - 1}\right)^2} = 9.5238 \frac{h^2}{\mu} \frac{1}{e^2 - 1}$$

Using Equation 3.40

$$r = 9.5238 \left[ r_{\text{perigee}} (1 + e) \right] \frac{1}{e^2 - 1} = 9.5238 \frac{r_{\text{perigee}}}{e - 1}$$

**Problem 2.26**

$$v_\infty = \frac{\mu}{h} \sqrt{e^2 - 1} = \frac{398\,600}{105\,000} \sqrt{3^2 - 1} = \underline{10.737 \text{ km/s}}$$

**Problem 2.27**

(a)

$$r_1 = \frac{h^2}{\mu} \frac{1}{1 + e \cos \theta_1}$$

$$6378 + 1700 = \frac{h^2}{398\,600} \frac{1}{1 + e \cos 130^\circ}$$

$$h^2 = (3.2199 - 2.0697e) \times 10^9$$

$$r_2 = \frac{h^2}{\mu} \frac{1}{1 + e \cos \theta_2}$$

$$6378 + 500 = \frac{h^2}{398\,600} \frac{1}{1 + e \cos 50^\circ}$$

$$h^2 = (2.7416 + 1.7622e) \times 10^9$$

$$(3.2199 - 2.0697e) \times 10^9 = (2.7416 + 1.7622e) \times 10^9$$

$$3.832e = 0.478\,32$$

$$e = \underline{\underline{0.124\,82}}$$

(b)

$$h^2 = (2.7416 + 1.7622 \cdot 0.124\,82) \times 10^9 = 2.9615 \times 10^9 \text{ km}^4/\text{s}^2$$

$$r_{\text{perigee}} = \frac{h^2}{\mu} \frac{1}{1 + e} = \frac{2.9615 \times 10^9}{398\,600} \frac{1}{1 + 0.124\,82} = 6605.4 \text{ km}$$

$$z_{\text{perigee}} = 6605.4 - 6378 = \underline{\underline{227.35 \text{ km}}}$$

(c) From Equation 3.63,

$$a = \frac{r_{\text{perigee}}}{1 - e} = \frac{6605.4}{1 - 0.124\,82} = \underline{\underline{7547.5 \text{ km}}}$$

---

**Problem 2.28**(a)  $\frac{v_r}{v_\perp} = \tan \gamma = \tan 15^\circ = 0.26795 \Rightarrow v_r = 0.26795 v_\perp$ 

$$v^2 = v_r^2 + v_\perp^2$$

$$7^2 = (0.26795 v_\perp)^2 + v_\perp^2$$

$$\therefore v_\perp = 6.7615 \text{ km/s}$$

$$v_r = 1.8117 \text{ km/s}$$

$$h = r v_\perp = 9000 \cdot 6.7615 = 60\,853 \text{ km}^2/\text{s}$$

$$v_r = \frac{\mu}{h} e \sin \theta$$

$$1.8117 = \frac{398\,600}{60\,853} e \sin \theta$$

$$e \sin \theta = 0.27659$$

$$r = \frac{h^2}{\mu} \frac{1}{1 + e \cos \theta}$$

$$9000 = \frac{60\,853^2}{398\,600} \frac{1}{1 + e \cos \theta}$$

$$e \cos \theta = 0.032259$$

$$\tan \theta = \frac{e \sin \theta}{e \cos \theta} = \frac{0.27659}{0.032259} = 8.574 \Rightarrow \theta = 83.348^\circ$$

(b)

$$e \cos 83.348^\circ = 0.032259 \Rightarrow e = 0.27847$$

**Problem 2.29** From Equation 3.50,

$$\varepsilon = -\frac{1}{2} \frac{\mu^2}{h^2} (1 - e^2)$$

$$-20 = -\frac{1}{2} \frac{398\,600^2}{60\,000^2} (1 - e^2) \Rightarrow e = 0.30605$$

$$r_{\text{perigee}} = \frac{h^2}{\mu} \frac{1}{1 + e} = \frac{60\,000^2}{398\,600} \frac{1}{1 + 0.30605} = 6915.2 \text{ km}$$

$$z_{\text{perigee}} = 6915.2 - 6378 = \underline{537.21 \text{ km}}$$

$$r_{\text{apogee}} = \frac{h^2}{\mu} \frac{1}{1 - e} = \frac{60\,000^2}{398\,600} \frac{1}{1 - 0.30605} = 13\,015 \text{ km}$$

$$z_{\text{apogee}} = 13\,015 - 6378 = \underline{6636.8 \text{ km}}$$

**Problem 2.30**

(a)

$$v_{\perp} = v \cos \gamma = 8.85 \cdot \cos 6^\circ = 8.8015 \text{ km/s}$$

$$h = r v_{\perp} = (6378 + 550) \cdot 8.8015 = 60\,977 \text{ km}^2/\text{s}$$

$$r = \frac{h^2}{\mu} \frac{1}{1 + e \cos \theta}$$

$$6928 = \frac{60\,977^2}{398\,600} \frac{1}{1 + e \cos \theta} \Rightarrow e \cos \theta = 0.34644$$

$$v_r = v \sin \gamma = 8.85 \cdot \sin 6^\circ = 0.92508 \text{ km/s}$$

$$v_r = \frac{\mu}{h} e \sin \theta$$

$$0.92508 = \frac{398\,600}{60\,977} e \sin \theta \Rightarrow e \sin \theta = 0.14152$$

$$\therefore \tan \theta = \frac{e \sin \theta}{e \cos \theta} = 0.40849 \Rightarrow \theta = 22.22^\circ$$

$$e \sin 22.22^\circ = 0.14152 \Rightarrow e = 0.37423$$

(b)

$$T = \frac{2\pi}{\mu^2} \left( \frac{h}{\sqrt{1 - e^2}} \right)^3 = \frac{2\pi}{398\,600^2} \left( \frac{60\,977}{\sqrt{1 - 0.37423^2}} \right)^3 = 11\,243 \text{ s} = \underline{187.39 \text{ m}}$$

**Problem 2.31**

$$v_{\perp} = v \cos \gamma = 10 \cdot \cos 30^{\circ} = 8.6603 \text{ km/s}$$

$$h = rv_{\perp} = (10\,000) \cdot 8.6603 = 86\,603 \text{ km}^2/\text{s}$$

$$r = \frac{h^2}{\mu} \frac{1}{1 + e \cos \theta}$$

$$10\,000 = \frac{86\,603^2}{398\,600} \frac{1}{1 + e \cos \theta} \Rightarrow e \cos \theta = 0.88159$$

$$v_r = v \sin \gamma = 10 \cdot \sin 30^{\circ} = 5 \text{ km/s}$$

$$v_r = \frac{\mu}{h} e \sin \theta$$

$$5 = \frac{398\,600}{86\,603} e \sin \theta \Rightarrow e \sin \theta = 1.0863$$

$$\therefore \tan \theta = \frac{e \sin \theta}{e \cos \theta} = 1.2323 \Rightarrow \theta = 50.94^{\circ}$$

**Problem 2.32**

$$v_{\perp} = v \cos \gamma = 10 \cdot \cos 20^{\circ} = 9.3969 \text{ km/s}$$

$$h = rv_{\perp} = (15\,000) \cdot 9.3969 = 140\,950 \text{ km}^2/\text{s}$$

$$r = \frac{h^2}{\mu} \frac{1}{1 + e \cos \theta}$$

$$15\,000 = \frac{140\,950^2}{398\,600} \frac{1}{1 + e \cos \theta} \Rightarrow e \cos \theta = 2.323$$

$$v_r = v \sin \gamma = 10 \cdot \sin 20^{\circ} = 3.4202 \text{ km/s}$$

$$v_r = \frac{\mu}{h} e \sin \theta$$

$$3.4202 = \frac{398\,600}{140\,950} e \sin \theta \Rightarrow e \sin \theta = 1.2095$$

$$\therefore \tan \theta = \frac{e \sin \theta}{e \cos \theta} = 0.52065 \Rightarrow \theta = 27.504^{\circ}$$

**Problem 2.33** Using the orbit equation  $r = \frac{h^2}{\mu} \frac{1}{1 + e \cos \theta}$  we find

$$\frac{h^2}{\mu} = 10\,000(1 + e \cos 30^{\circ}) = 10\,000 + 8660.3e$$

$$\frac{h^2}{\mu} = 30\,000(1 + e \cos 105^{\circ}) = 30\,000 - 7764.6e$$

$$\therefore 10\,000 + 8660.3e = 30\,000 - 7764.6e$$

$$16\,425e = 20\,000 \Rightarrow e = 1.2177$$

**Problem 2.34**

$$v_1 = \sqrt{\frac{\mu}{r}} = \sqrt{\frac{398\,600}{6378 + 500}} = 7.6127 \text{ km/s}$$

$$v_2 = v_1 + \frac{v_1}{2} = 11.419 \text{ km/s}$$

$$\frac{v_\infty^2}{2} - \frac{\mu}{\infty} = \frac{v_2^2}{2} - \frac{\mu}{r}$$

$$\frac{v_\infty^2}{2} = \frac{11.419^2}{2} - \frac{398\,600}{6878} = 7.2441 \Rightarrow \underline{v_\infty = 3.8062 \text{ km/s}}$$

**Problem 2.35**

$$v_1 = \sqrt{\frac{\mu}{r}} = \sqrt{\frac{398\,600}{6378 + 320}} = 7.7143 \text{ km/s}$$

$$v_{\text{perigee}} = v_1 + 0.5 = 8.2143 \text{ km/s}$$

$$h = r_{\text{perigee}} v_{\text{perigee}} = 6698 \cdot 8.2143 = 55\,019$$

$$r_{\text{perigee}} = \frac{h^2}{\mu} \frac{1}{1+e}$$

$$6698 = \frac{55\,019^2}{398\,600} \frac{1}{1+e} \Rightarrow e = 0.13383$$

$$r_{\text{apogee}} = \frac{h^2}{\mu} \frac{1}{1-e} = \frac{55\,019^2}{398\,600} \frac{1}{1-0.13383} = 8767.8 \text{ km}$$

$$z_{\text{apogee}} = 8767.8 - 6378 = \underline{2389.8 \text{ km}}$$

**Problem 2.36**

$$v = \sqrt{\frac{\mu}{r_{\text{perigee}}}}$$

$$v_{\text{perigee}} = v + \alpha v = (1 + \alpha) \sqrt{\frac{\mu}{r_{\text{perigee}}}}$$

$$h = r_{\text{perigee}} v_{\text{perigee}} = r_{\text{perigee}} (1 + \alpha) \sqrt{\frac{\mu}{r_{\text{perigee}}}} = (1 + \alpha) \sqrt{\mu r_{\text{perigee}}}$$

$$r_{\text{perigee}} = \frac{h^2}{\mu} \frac{1}{1+e} = \frac{(1 + \alpha)^2 \mu r_{\text{perigee}}}{\mu} \frac{1}{1+e}$$

$$\therefore 1 + e = (1 + \alpha)^2$$

$$1 + e = 1 + 2\alpha + \alpha^2 \Rightarrow \underline{e = \alpha(\alpha + 2)}$$

**Problem 2.37**

(a)

$$v_1 = \sqrt{\frac{\mu}{r}} = \sqrt{\frac{398\,600}{6378 + 400}} = 7.6686 \text{ km/s}$$

$$v_{\perp 2} = v_1 + 0.24 = 7.9086 \text{ km/s}$$

$$h_2 = r v_{\perp 2} = 6778 \cdot 7.9086 = 53\,605 \text{ km}^2/\text{s}$$

$$r = \frac{h_2^2}{\mu} \frac{1}{1+e}$$

$$6778 = \frac{53\,605^2}{398\,600} \frac{1}{1+e} \Rightarrow e = 0.063572$$

$$z_{\text{perigee}_2} = \underline{400 \text{ km}}$$

$$6378 + z_{\text{apogee}_2} = \frac{h_2^2}{\mu} \frac{1}{1-e} = \frac{53\,605^2}{398\,600} \frac{1}{1-0.063572} \Rightarrow \underline{z_{\text{apogee}_2} = 1320.3 \text{ km}}$$

(b)

$$v_{\perp 2} = \sqrt{\frac{\mu}{r}} = \sqrt{\frac{398\,600}{6378 + 400}} = 7.6686 \text{ km/s}$$

$$h_2 = r v_{\perp 2} = 6778 \cdot 7.6686 = 51\,978 \text{ km}^2/\text{s}$$

$$v_{r2} = \frac{\mu}{h_2} e_2 \sin \theta$$

$$0.24 = \frac{398\,600}{51\,978} e_2 \sin \theta \Rightarrow e_2 \sin \theta = 0.031296$$

$$r = \frac{h_2^2}{\mu} \frac{1}{1 + e_2 \cos \theta}$$

$$6778 = \frac{51\,978^2}{398\,600} \frac{1}{1 + e_2 \cos \theta} \Rightarrow e_2 \cos \theta = 0 \Rightarrow \theta = 90^\circ \text{ (since } e \text{ cannot be zero if } v_r \neq 0)$$

$$e_2 \sin 90^\circ = 0.031296 \Rightarrow e_2 = 0.031296$$

$$6378 + z_{\text{perigee}_2} = \frac{h_2^2}{\mu} \frac{1}{1+e} = \frac{51\,978^2}{398\,600} \frac{1}{1+0.031296} \Rightarrow \underline{z_{\text{perigee}_2} = 196.49 \text{ km}}$$

$$6378 + z_{\text{apogee}_2} = \frac{h_2^2}{\mu} \frac{1}{1-e} = \frac{51\,978^2}{398\,600} \frac{1}{1-0.031296} \Rightarrow \underline{z_{\text{apogee}_2} = 631.3 \text{ km}}$$

**Problem 2.38** In Figure 3.30

$$m_1 = m_{\text{sun}} = 1.989 \times 10^{30} \text{ kg}$$

$$m_2 = m_{\text{earth}} = 5.974 \times 10^{24} \text{ kg}$$

$$r_{12} = 149.6 \times 10^6 \text{ km}$$

From Equation 3.169

$$\pi_2 = \frac{m_2}{m_1 + m_2} = 3.0035 \times 10^{-6}$$

Substitute  $\pi_2$  into Equation 3.195,

$$f(\xi) = \frac{1 - \pi_2}{|\xi + \pi_2|^3} (\xi + \pi_2) + \frac{\pi_2}{|\xi + \pi_2 - 1|^3} (\xi + \pi_2 - 1) - \xi$$

The graph of  $f(\xi)$  is similar to Figure 3.33, with the two crossings on the right much more closely spaced. Zeroing in on the regions where  $f(\xi) = 0$ , with the aid of a computer, reveals

$$\xi_1 = 0.990\,026\,6$$

$$\xi_2 = 1.010\,034$$

$$\xi_3 = -1.000\,001$$

Then,

$$x_1 = \xi_1 r_{12} = \underline{148.108 \times 10^6 \text{ km}}$$

$$x_2 = \xi_2 r_{12} = \underline{151.101 \times 10^6 \text{ km}}$$

$$x_3 = \xi_3 r_{12} = \underline{-149.600 \times 10^6 \text{ km}}$$

These are the locations of  $L_1$ ,  $L_2$  and  $L_3$  relative to the center of mass of the sun-earth system (essentially the center of the sun).

---





**Problem 3.1** Graph the function

$$f = x^2 - 5x + 4 - 10e^{\sin x}$$

to get an idea where the roots lie.

$$f' = 2x - 5 - 10 \cos x e^{\sin x}$$

$$x_{i+1} = x_i - \frac{f(x_i)}{f'(x_i)}$$

$$x_{i+1} = x_i - \frac{x_i^2 - 5x_i + 4 - 10e^{\sin x_i}}{2x_i - 5 - 10 \cos x_i e^{\sin x_i}}$$



First root:

$$\begin{aligned} x_0 &= 4 \quad (\text{Estimate}) \\ x_1 &= 4.7733482 \\ x_2 &= 4.9509264 \\ x_3 &= 4.9577657 \\ x_4 &= 4.9577768 \\ x_5 &= \underline{4.9577768} \end{aligned}$$

Second root:

$$\begin{aligned} x_0 &= 7 \quad (\text{Estimate}) \\ x_1 &= 6.7673080 \\ x_2 &= 6.7732223 \\ x_3 &= 6.7732128 \\ x_5 &= \underline{6.7732128} \end{aligned}$$

Third root:

$$\begin{aligned} x_0 &= 8 \quad (\text{Estimate}) \\ x_1 &= 7.9259101 \\ x_2 &= 7.9198260 \\ x_3 &= 7.9197836 \\ x_4 &= \underline{7.9197836} \end{aligned}$$

**Problem 3.2** Graph the function

$$f = \tan x - \tanh x$$

to get an idea where the roots lie.  
Clearly, the first root is  $x = 0$ .

$$f' = \sec^2 x - \operatorname{sech}^2 x$$

$$x_{i+1} = x_i - \frac{f(x_i)}{f'(x_i)}$$

$$x_{i+1} = x_i - \frac{\tan x_i - \tanh x_i}{\sec^2 x_i - \operatorname{sech}^2 x_i}$$

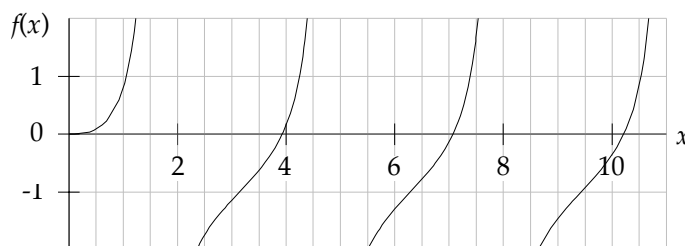

Second root:

$$\begin{aligned} x_0 &= 4 \quad (\text{Estimate}) \\ x_1 &= 3.9322455 \\ x_2 &= 3.9266343 \\ x_3 &= 3.9266023 \\ x_4 &= \underline{3.9266023} \end{aligned}$$

Third root:

$$\begin{aligned} x_0 &= 7 \quad (\text{Estimate}) \\ x_1 &= 7.0730641 \\ x_2 &= 7.0686029 \\ x_3 &= 7.0685827 \\ x_5 &= \underline{7.0685827} \end{aligned}$$

Fourth root:

$$\begin{aligned} x_0 &= 10 \quad (\text{Estimate}) \\ x_1 &= 10.247568 \\ x_2 &= 10.211608 \\ x_3 &= 10.210178 \\ x_4 &= 10.210176 \\ x_5 &= \underline{10.210176} \end{aligned}$$

**Problem 3.3**

$$a = \frac{1}{2}(r_{\text{apogee}} + r_{\text{perigee}}) = \frac{1}{2}(6978 + 6578) = 6778 \text{ km}$$

$$T = \frac{2\pi}{\sqrt{\mu}} a^{3/2} = \frac{2\pi}{\sqrt{398\,600}} 6778^{3/2} = 5553.5 \text{ s}$$

$$e = \frac{r_{\text{apogee}} - r_{\text{perigee}}}{r_{\text{apogee}} + r_{\text{perigee}}} = \frac{6978 - 6578}{6978 + 6578} = 0.029\,507$$

Let  $B$  denote the point where the satellite flies through 400 km altitude on the way to apogee.

$$r_B = \frac{a(1-e^2)}{1+e \cos \theta_B}$$

$$6378 + 400 = \frac{6778(1-0.029\,507^2)}{1+0.029\,507 \cos \theta_B} \Rightarrow \theta_B = 91.691^\circ$$

$$\tan \frac{E_B}{2} = \sqrt{\frac{1-e}{1+e}} \tan \frac{\theta_B}{2} = \sqrt{\frac{1-0.029\,507}{1+0.029\,507}} \tan \frac{91.691^\circ}{2} \Rightarrow E_B = 1.5708 \text{ rad}$$

$$M_B = E_B - e \sin E_B = 1.5708 - 0.029\,507 \sin 1.5708 = 1.5413 \text{ rad}$$

$$t_B = \frac{M_B T}{2\pi} = \frac{1.5413 \cdot 5553.5}{2\pi} = 1362.3 \text{ s}$$

$t_B$  is the time after perigee at which the spacecraft goes above 400 km. Let  $C$  denote the point at which the satellite flies downward through 400 km altitude on its way to perigee. The time of flight  $t_{BC}$  from  $B$  to  $C$  is

$$t_{BC} = T - 2t_B = 5553.5 - 2 \cdot 1362.3 = 2828.9 \text{ s} = \underline{47.148 \text{ m}}$$

### Problem 3.4

(a)

$$a = \frac{1}{2}(r_{\text{apogee}} + r_{\text{perigee}}) = \frac{1}{2}(10\,000 + 7\,000) = 8500 \text{ km}$$

$$T = \frac{2\pi}{\sqrt{\mu}} a^{3/2} = \frac{2\pi}{\sqrt{398\,600}} 8500^{3/2} = 7799 \text{ s}$$

$$e = \frac{r_{\text{apogee}} - r_{\text{perigee}}}{r_{\text{apogee}} + r_{\text{perigee}}} = \frac{10\,000 - 7\,000}{10\,000 + 7\,000} = 0.176\,47$$

$$t_1 = 0.5 \cdot 3600 = 1800 \text{ s}$$

$$M_1 = \frac{2\pi t_1}{T} = \frac{2\pi \cdot 1800}{7799} = 1.4501 \text{ rad}$$

$$E_1 - e \sin E_1 = M_1$$

$$E_1 - 0.176\,47 \sin E_1 = 1.4501$$

$$E_1 = 1.6263 \text{ rad (Algorithm 3.1)}$$

$$\therefore \tan \frac{\theta_1}{2} = \sqrt{\frac{1+e}{1-e}} \tan \frac{E_1}{2} = \sqrt{\frac{1+0.176\,47}{1-0.176\,47}} \tan \frac{1.6263}{2} \Rightarrow \theta_1 = 103.28^\circ$$

$$t_2 = 1.5 \cdot 3600 = 5400 \text{ s}$$

$$M_2 = \frac{2\pi t_2}{T} = \frac{2\pi \cdot 5400}{7799} = 4.3504 \text{ rad}$$

$$E_2 - e \sin E_2 = M_2$$

$$E_2 - 0.176\,47 \sin E_2 = 4.3504$$

$$E_2 = 4.1969 \text{ rad (Algorithm 3.1)}$$

$$\tan \frac{\theta_2}{2} = \sqrt{\frac{1+e}{1-e}} \tan \frac{E_2}{2} = \sqrt{\frac{1+0.176\,47}{1-0.176\,47}} \tan \frac{4.1969}{2} \Rightarrow \theta_2 = 231.99^\circ$$

$$\Delta\theta = \theta_2 - \theta_1 = \underline{128.7^\circ}$$

(b)

$$h = \sqrt{\mu r_{\text{perigee}} (1+e)} = \sqrt{398\,600 \cdot 7\,000 \cdot (1+0.176\,47)} = 57\,294 \text{ km}^2/\text{s}$$

$$\frac{\Delta A}{\Delta t} = \frac{h}{2}$$

$$\Delta t = 3600 \text{ s}$$

$$\therefore \Delta A = \frac{1}{2} h \Delta t = \frac{1}{2} 57\,294 \cdot 3600 = \underline{103.13 \times 10^6 \text{ km}^2}$$

**Problem 3.5**

(a)

$$T = \frac{2\pi}{\sqrt{\mu}} a^{3/2}$$

$$15.743 \cdot 3600 = \frac{2\pi}{\sqrt{398\,600}} a^{3/2} \Rightarrow a = 31\,890 \text{ km}$$

$$a = \frac{1}{2} (r_{\text{perigee}} + r_{\text{apogee}})$$

$$31\,890 = \frac{1}{2} (12\,756 + r_{\text{apogee}}) \Rightarrow r_{\text{apogee}} = 51\,024 \text{ km}$$

$$e = \frac{r_{\text{apogee}} - r_{\text{perigee}}}{r_{\text{apogee}} + r_{\text{perigee}}} = \frac{51\,024 - 12\,756}{51\,024 + 12\,756} = 0.6000$$

$$M = 2\pi \frac{t}{T} = 2\pi \frac{10}{15.743} = 3.9911 \text{ rad}$$

$$E - e \sin E = M$$

$$E - 0.6 \sin E = 3.9911$$

$$E = 3.6823 \text{ rad (Algorithm 3.1)}$$

$$\tan \frac{\theta}{2} = \sqrt{\frac{1+e}{1-e}} \tan \frac{E}{2} = \sqrt{\frac{1+0.6}{1-0.6}} \tan \frac{3.6823}{2} \Rightarrow \theta = 195.78^\circ$$

$$r = \frac{a(1-e^2)}{1+e \cos \theta} = \frac{31\,890(1-0.6^2)}{1+0.6 \cos 195.78^\circ} = \underline{48\,924 \text{ km}}$$

(b)

$$\frac{v^2}{2} - \frac{\mu}{r} = -\frac{\mu}{2a}$$

$$\frac{v^2}{2} - \frac{398\,600}{48\,924} = -\frac{398\,600}{2 \cdot 31\,890} \Rightarrow \underline{v = 2.0019 \text{ km/s}}$$

(c)

$$h = \sqrt{\mu a (1-e^2)} = \sqrt{398\,600 \cdot 31\,890 \cdot (1-0.6^2)} = 90\,196 \text{ km}^2/\text{s}$$

$$v_r = \frac{\mu}{h} e \sin \theta = \frac{398\,600}{90\,196} \cdot 0.6 \cdot \sin 195.78^\circ = \underline{-0.72097 \text{ km/s}}$$

**Problem 3.6**

(a)

$$M_{PB} = E - e \sin E$$

$$\frac{2\pi t_{PB}}{T} = \frac{\pi}{2} - e \sin \frac{\pi}{2}$$

$$t_{PB} = \left( \frac{\pi}{2} - e \right) \frac{T}{2\pi}$$

$$t_{DPB} = 2t_{PB} = \underline{\left( \frac{1}{2} - \frac{e}{\pi} \right) T}$$

(b)

$$t_{BA} = \frac{T}{2} - t_{PB}$$

$$t_{BA} = \frac{T}{2} - \left( \frac{\pi}{2} - e \right) \frac{T}{2\pi} = \underline{\left( \frac{1}{4} + \frac{e}{2\pi} \right) T}$$

$$t_{BAD} = 2t_{BA} = \left(\frac{1}{2} + \frac{e}{\pi}\right)T$$

**Problem 3.7**

$$\tan \frac{E_B}{2} = \sqrt{\frac{1-e}{1+e}} \tan \frac{\theta_B}{2} = \sqrt{\frac{1-0.3}{1+0.3}} \tan \frac{\pi}{4} = 0.73380 \Rightarrow E_B = 1.2661 \text{ rad}$$

$$M_B = E_B - e \sin E_B = 1.2661 - 0.6 \sin 1.2661 = 0.97992 \text{ rad}$$

$$t_B = \frac{M_B}{2\pi} T = \frac{0.97992}{2\pi} T = 0.48996T$$

**Problem 3.8**

$$a = \frac{r_{\text{apogee}} + r_{\text{perigee}}}{2} = \frac{14000 + 7000}{2} = 10500 \text{ km}$$

$$e = \frac{r_{\text{apogee}} - r_{\text{perigee}}}{r_{\text{apogee}} + r_{\text{perigee}}} = \frac{14000 - 7000}{14000 + 7000} = 0.33333$$

$$T = \frac{2\pi}{\sqrt{\mu}} a^{3/2} = \frac{2\pi}{\sqrt{398600}} 10500^{3/2} = 10708 \text{ s}$$

$$\tan \frac{E_{\theta=60^\circ}}{2} = \sqrt{\frac{1-e}{1+e}} \tan \left(\frac{60^\circ}{2}\right) = \sqrt{\frac{1-0.33333}{1+0.33333}} \tan(30^\circ) = 0.40825 \Rightarrow E_{\theta=60^\circ} = 0.77519 \text{ rad}$$

$$M_{\theta=60^\circ} = 0.77519 - 0.33333 \sin(0.77519) = 0.54191 \text{ rad}$$

$$t_{\theta=60^\circ} = \frac{M_{\theta=60^\circ}}{2\pi} T = \frac{0.54191}{2\pi} 10708 = 923.51 \text{ s}$$

$$t_\theta = t_{\theta=60^\circ} + 30 \cdot 60 = 2723.5 \text{ s}$$

$$M_\theta = 2\pi \frac{t_\theta}{T} = 2\pi \frac{2723.5}{10708} = 1.5981 \text{ rad}$$

$$E_\theta - e \sin E_\theta = M_\theta$$

$$E_\theta - 0.33333 \sin E_\theta = 1.5981 \Rightarrow E_\theta = 1.9122 \text{ rad (Algorithm 3.1)}$$

$$\tan \frac{\theta}{2} = \sqrt{\frac{1+e}{1-e}} \tan \frac{E_\theta}{2} = \sqrt{\frac{1+0.33333}{1-0.33333}} \tan \frac{1.9122}{2} \Rightarrow \theta = 126.95^\circ$$

**Problem 3.9**

$$a \cos \theta + b \sin \theta = c$$

$$\cos \theta + \frac{b}{a} \sin \theta = \frac{c}{a}$$

$$\frac{b}{a} \equiv \tan \phi = \frac{\sin \phi}{\cos \phi}$$

$$\cos \theta + \frac{\sin \phi}{\cos \phi} \sin \theta = \frac{c}{a}$$

$$\cos \theta \cos \phi + \sin \theta \sin \phi = \frac{c}{a} \cos \phi$$

$$\cos(\theta - \phi) = \frac{c}{a} \cos \phi$$

$$\theta - \phi = \pm \cos^{-1} \left( \frac{c}{a} \cos \phi \right)$$

$$\theta = \phi \pm \cos^{-1} \left( \frac{c}{a} \cos \phi \right)$$

**Problem 3.10**

$$M_B = E_B - e \sin E_B$$

$$2\pi \frac{t_B}{T} = \frac{\pi}{2} - e \sin \frac{\pi}{2}$$

$$t_B = \frac{\frac{\pi}{2} - e \sin \frac{\pi}{2}}{2\pi} T = \underline{(0.25 - 0.15915e)T}$$

**Problem 3.11**

$$\left. \begin{aligned} r &= \frac{h^2}{\mu} \frac{1}{1 + e \cos \theta} \\ r_{\text{perigee}} &= \frac{h^2}{\mu} \frac{1}{1 + e} \end{aligned} \right\} \Rightarrow r = \frac{r_{\text{perigee}}(1 + e)}{1 + e \cos \theta}$$

$$2r_{\text{perigee}} = \frac{r_{\text{perigee}}(1 + 0.5)}{1 + 0.5 \cos \theta_B}$$

$$\cos \theta_B = -0.5 \Rightarrow \theta_B = 120^\circ$$

$$\tan \frac{E_B}{2} = \sqrt{\frac{1-e}{1+e}} \tan \frac{\theta_B}{2} = \sqrt{\frac{1-0.5}{1+.5}} \tan \frac{120^\circ}{2} \Rightarrow E_B = \frac{\pi}{2} \text{ rad}$$

$$M_B = E_B - e \sin E_B = \frac{\pi}{2} - 0.5 \sin \frac{\pi}{2} = 1.0708 \text{ rad}$$

$$t_B = \frac{M_B}{2\pi} T = \frac{1.0708}{2\pi} T = \underline{0.17042T}$$

**Problem 3.12** From Example 3.3 we have

$$e = 0.24649$$

$$T = 8679.1 \text{ s}$$

$$\theta_c = 143.36$$

Thus

$$\tan \frac{E_c}{2} = \sqrt{\frac{1-e}{1+e}} \tan \frac{\theta_c}{2} = \sqrt{\frac{1-0.24649}{1+0.24649}} \tan \frac{143.36^\circ}{2} \Rightarrow \underline{E_c = 2.3364 \text{ rad}}$$

$$M_c = E_c - e \sin E_c = 2.3364 - 0.24649 \cdot \sin 2.3364 = \underline{2.1587 \text{ rad}}$$

$$t_c = \frac{M_c}{2\pi} T = \frac{2.1587}{2\pi} \cdot 8679.1 = \underline{2981.8 \text{ s}}$$

**Problem 3.13**

$$r_{\text{SOI}} = 925000 \text{ km}$$

$$r = \frac{r_{\text{perigee}}(1 + e)}{1 + e \cos \theta}$$

$$925000 = \frac{(6378 + 500)(1 + 1)}{1 + 1 \cdot \cos \theta} \Rightarrow \theta = 170.11^\circ$$

$$M_p = \frac{1}{2} \tan \frac{\theta}{2} + \frac{1}{6} \tan^3 \frac{\theta}{2} = \frac{1}{2} \tan \frac{170.11^\circ}{2} + \frac{1}{6} \tan^3 \frac{170.11^\circ}{2} = 262.82$$

$$r_{\text{perigee}} = \frac{h^2}{2\mu} \Rightarrow h = \sqrt{2\mu r_{\text{perigee}}} = \sqrt{2 \cdot 398600 \cdot 6878} = 74048 \text{ km}^2/\text{s}$$

$$t = \frac{h^3}{\mu} M_p = \frac{74\,048^3}{398\,600} \cdot 262.82 = 671\,630 \text{ s} = \underline{7\text{d } 18\text{h } 34\text{m}}$$

**Problem 3.14**

(a)

$$h = \sqrt{\mu r_{\text{perigee}}(1+e)} = \sqrt{398\,600 \cdot 7500 \cdot (1+1)} = 77\,324 \text{ km}^2/\text{s}$$

$$M_p)_{\theta=90^\circ} = \frac{1}{2} \tan \frac{90^\circ}{2} + \frac{1}{6} \tan^3 \frac{90^\circ}{2} = 0.66667$$

$$t_{\theta=90^\circ} = \frac{h^3}{\mu^2} M_p)_{\theta=90^\circ} = \frac{77\,324^3}{398\,600^2} \cdot 0.66667 = 1939.9 \text{ s}$$

$$t_{-90^\circ \text{ to } +90^\circ} = 2 \cdot 1939.9 = 3879.8 \text{ s} = \underline{1.0777 \text{ h}}$$

(b)

$$M_p = \frac{\mu^2 t}{h^3} = \frac{398\,600^3 \cdot (24 \cdot 3600)}{77\,324^3} = 29.692$$

$$\tan \frac{\theta}{2} = \left[ 3M_p + \sqrt{(3M_p)^2 + 1} \right]^{1/3} - \left[ 3M_p + \sqrt{(3M_p)^2 + 1} \right]^{-1/3}$$

$$\tan \frac{\theta}{2} = \left[ 3 \cdot 29.692 + \sqrt{(3 \cdot 29.692)^2 + 1} \right]^{1/3} - \left[ 3 \cdot 29.692 + \sqrt{(3 \cdot 29.692)^2 + 1} \right]^{-1/3} = 5.4492$$

$$\theta = 159.2^\circ$$

$$r = \frac{h^2}{\mu} \frac{1}{1 + \cos \theta} = \frac{77\,324^2}{398\,600} \frac{1}{1 + \cos 159.2^\circ} = \underline{230\,200 \text{ km}}$$

**Problem 3.15**

(a)

$$v_{\text{perigee}} = 1.1 \sqrt{\frac{2\mu}{r_{\text{perigee}}}} = 1.1 \sqrt{\frac{2 \cdot 398\,600}{7500}} = 11.341 \text{ km/s}$$

$$h = r_{\text{perigee}} v_{\text{perigee}} = 7500 \cdot 11.341 = 85\,056 \text{ km}^2/\text{s}$$

$$r_{\text{perigee}} = \frac{h^2}{\mu} \frac{1}{1+e}$$

$$7500 = \frac{85\,056^2}{398\,600} \frac{1}{1+e} \Rightarrow e = 1.4200$$

$$\tanh \frac{F_{90^\circ}}{2} = \sqrt{\frac{e-1}{e+1}} \tan \frac{90^\circ}{2} = \sqrt{\frac{1.42-1}{1.42+1}} \tan \frac{90^\circ}{2} \Rightarrow F_{90^\circ} = 0.887\,14$$

$$M_h)_{90^\circ} = e \sinh F_{90^\circ} - F_{90^\circ} = 1.42 \cdot \sinh 0.88714 - 0.88714 = 0.544\,46$$

$$M_h)_{90^\circ} = \frac{\mu^2}{h^3} (e^2 - 1)^{3/2} t_{90^\circ}$$

$$0.544\,46 = \frac{398\,600^2}{85\,056^3} (1.42^2 - 1)^{3/2} t_{90^\circ} \Rightarrow t_{90^\circ} = 2057.9 \text{ s}$$

$$t_{-90^\circ \text{ to } 90^\circ} = 2t_{90^\circ} = \underline{4115.7 \text{ s}} = \underline{1.1433 \text{ h}}$$

(b)

$$M_h = \frac{\mu^2}{h^3} (e^2 - 1)^{3/2} t = \frac{398\,600^2}{85\,056^3} (1.42^2 - 1)^{3/2} \cdot 24 \cdot 3600 = 22.859$$

$$e \sinh F - F = M_h$$

$$1.42 \sinh F - F = 22.859 \Rightarrow F = 3.6196 \text{ (Algorithm 3.2)}$$

$$\tan \frac{\theta}{2} = \sqrt{\frac{e+1}{e-1}} \tanh \frac{F}{2} = \sqrt{\frac{1.42+1}{1.42-1}} \tanh \frac{3.6196}{2} \Rightarrow \theta = 132.55^\circ$$

$$r = \frac{h^2}{\mu} \frac{1}{1+e \cos \theta} = \frac{85056^2}{398\,600} \frac{1}{1+1.42 \cdot \cos 132.55^\circ} = \underline{455\,660 \text{ km}}$$

**Problem 3.16**

$$h = r_{\text{perigee}} v_{\text{perigee}} = (6378 + 300) \cdot 11.5 = 76\,797 \text{ km}^2/\text{s}$$

$$r_{\text{perigee}} = \frac{h^2}{\mu} \frac{1}{1+e}$$

$$e = \frac{h^2}{\mu r_{\text{perigee}}} - 1 = \frac{76\,797^2}{398\,600 \cdot 6878} - 1 = 1.2157 \text{ (hyperbola)}$$

$$a = \frac{h^2}{\mu} \frac{1}{e^2 - 1} = \frac{76\,797^2}{398\,600} \frac{1}{1.2157^2 - 1} = 30\,964 \text{ km}$$

At 6 AM:

$$\frac{v^2}{2} - \frac{\mu}{r} = \frac{\mu}{2a}$$

$$\frac{10^2}{2} - \frac{398\,600}{r} = \frac{398\,600}{2 \cdot 30\,964} \Rightarrow r = 9149.9 \text{ km}$$

$$r = \frac{h^2}{\mu} \frac{1}{1+e \cos \theta}$$

$$9149.9 = \frac{76\,797^2}{398\,600} \frac{1}{1+1.2157 \cos \theta} \Rightarrow \theta = -59.494^\circ \text{ (flying towards earth)}$$

$$\tanh \frac{F}{2} = \sqrt{\frac{e-1}{e+1}} \tan \frac{\theta}{2} = \sqrt{\frac{1.2157-1}{1.2157+1}} \tan \frac{-59.494^\circ}{2} = -0.10384 \Rightarrow F = -0.360\,45$$

$$M_h = e \sinh F - F = 1.2157 \sinh(-0.360\,45) - (-0.360\,45) = -0.087\,287$$

$$M_h = \frac{\mu^2}{h^3} (e^2 - 1)^{3/2} t$$

$$-0.087\,287 = \frac{398\,600^2}{76\,797^3} (1.2157^2 - 1)^{3/2} t \Rightarrow t = -753.3 \text{ s (negative means time until perigee)}$$

At 11 AM:

$$t = 5 \cdot 3600 - |-753.3| = 17\,247 \text{ s (time since perigee at 11 AM)}$$

$$M_h = \frac{\mu^2}{h^3} (e^2 - 1)^{3/2} t_2 = \frac{398\,600^2}{76\,797^3} (1.2157^2 - 1)^{3/2} \cdot 17\,247 = 1.9984$$

$$e \sinh F - F = M_h$$

$$1.2157 \sinh F - F = 1.9984 \Rightarrow F = 1.8760 \text{ (Algorithm 3.2)}$$

$$\tanh \frac{\theta}{2} = \sqrt{\frac{e+1}{e-1}} \tanh \frac{F}{2} = \sqrt{\frac{1.2157+1}{1.2157-1}} \tanh \frac{1.8760}{2} \Rightarrow \theta = 133.96^\circ$$

$$r = \frac{h^2}{\mu} \frac{1}{1+e \cos \theta} = \frac{76\,797^2}{398\,600} \frac{1}{1+1.2157 \cdot \cos 133.96^\circ} = 94771 \text{ km}$$

$$z = r - 6378 = \underline{88\,393 \text{ km}}$$



**Problem 3.17**

$$v_{\perp} = v \cos \gamma = 8 \cdot \cos(-65^{\circ}) = 3.3809 \text{ km/s}$$

$$h = r v_{\perp} = (37\,000 + 6378) \cdot 3.3809 = 146\,660 \text{ km}^2/\text{s}$$

$$r = \frac{h^2}{\mu} \frac{1}{1 + e \cos \theta}$$

$$43\,378 = \frac{146\,660^2}{398\,600} \frac{1}{1 + e \cos \theta} \Rightarrow e \cos \theta = 0.24397$$

$$v_r = v \sin \gamma = 8 \cdot \sin(-65^{\circ}) = -7.2505 \text{ km/s}$$

$$v_r = \frac{\mu}{h} e \sin \theta$$

$$-7.2505 = \frac{398\,600}{146\,660} e \sin \theta \Rightarrow e \sin \theta = -2.6677$$

$$\tan \theta = \frac{e \sin \theta}{e \cos \theta} = \frac{-2.6677}{0.24397} = -10.935 \Rightarrow \theta = -84.775^{\circ}$$

$$e \sin(-84.775^{\circ}) = -2.6677 \Rightarrow e = 2.6788 \text{ (hyperbola)}$$

$$r_{\text{perigee}} = \frac{h^2}{\mu} \frac{1}{1 + e} = \frac{146\,660^2}{398\,600} \frac{1}{1 + 2.6788} = 14\,668 \text{ km (no impact)}$$

$$\tanh \frac{F}{2} = \sqrt{\frac{e-1}{e+1}} \tan \frac{\theta}{2} = \sqrt{\frac{2.6788-1}{2.6788+1}} \tan\left(\frac{-84.775^{\circ}}{2}\right) \Rightarrow F = -1.4389$$

$$M_h = e \sinh F - F = 2.6788 \sinh(-1.4389) - (-1.4389) = -3.8906$$

$$M_h = \frac{\mu^2}{h^3} (e^2 - 1)^{3/2} t$$

$$-3.8906 = \frac{398\,600^2}{46\,660^3} (2.6788^2 - 1)^{3/2} t \Rightarrow t = -5032.5 \text{ s} = -1.3979 \text{ h}$$

1.3979 hours until perigee passage.

**Problem 3.18** Write the following MATLAB script to use M-function `kepler_U` to implement Algorithm 3.3.

```
clear
global mu
mu = 398600;

ro = 7200;
vro = 1;
a = 10000;
dt = 3600;

x = kepler_U(dt, ro, vro, 1/a);

fprintf('\n\n-----\n')
fprintf('\n Initial radial coordinate = %g', ro)
fprintf('\n Initial radial velocity = %g', vro)
fprintf('\n Elapsed time = %g', dt)
fprintf('\n Semimajor axis = %g\n', a)
fprintf('\n Universal anomaly = %g', x)
fprintf('\n\n-----\n\n')
```

Running this program produces the following output in the MATLAB Command Window:

---

Initial radial coordinate	=	7200
Initial radial velocity	=	1
Elapsed time	=	3600
Semimajor axis	=	10000
Universal anomaly	=	229.341

---

That is,  $\chi = 229.34 \text{ km}^{1/2}$ . To check this with Equation 3.55, proceed as follows.

$$r = \frac{h^2}{\mu} \frac{1}{1 + e \cos \theta}$$

$$7200 = \frac{h^2}{398\,600} \frac{1}{1 + e \cos \theta}$$

$$\therefore \cos \theta = \frac{3.844 \times 10^{-10} h^2 - 1}{e} \quad (1)$$

$$v_r = \frac{\mu}{h} e \sin \theta$$

$$1 = \frac{398\,600}{h} e \sin \theta$$

$$\therefore \sin \theta = \frac{1}{398\,600} \frac{h}{e} \quad (2)$$

$$\sin^2 \theta + \cos^2 \theta = 1$$

Substitute (1) and (2):

$$\left( \frac{1}{398\,600} \frac{h}{e} \right)^2 + \left( \frac{3.844 \times 10^{-10} h^2 - 1}{e} \right)^2 = 1 \quad (3)$$

$$a = \frac{h^2}{\mu} \frac{1}{1 - e^2}$$

$$10\,000 = \frac{h^2}{398\,600} \frac{1}{1 - e^2}$$

$$\therefore h = \sqrt{3.986 \times 10^9 (1 - e^2)} \quad (4)$$

Substitute (4) into (3):

$$\left( \frac{1}{398\,600} \frac{\sqrt{3.986 \times 10^9 (1 - e^2)}}{e} \right)^2 + \left\{ \frac{3.844 \times 10^{-10} [3.986 \times 10^9 (1 - e^2)] - 1}{e} \right\}^2 = 1$$

Expanding and collecting terms yields

$$\frac{1}{1993e^2} (3844.5e^4 - 4195.9e^2 + 351.41) = 0$$

or

$$3844.5e^4 - 4195.9e^2 + 351.41 = 0$$

The positive roots of this equation are  $e = 1.0000$  and  $e = 0.30233$ . Obviously, we choose the latter.

$$e = 0.30233 \quad (5)$$

Substituting (5) into (4), we get

$$h = 60180 \text{ km}^2/\text{s} \quad (6)$$

Substituting (5) and (6) into (1) or (2) yields

$$\theta_1 = 29.959^\circ \quad (7)$$

Compute the time at this initial true anomaly as follows:

$$\tan \frac{E_1}{2} = \sqrt{\frac{1-e}{1+e}} \tan \frac{\theta_1}{2} = \sqrt{\frac{1-0.30233}{1+0.30233}} \tan \frac{29.959^\circ}{2} = 0.19584$$

$$\therefore E_1 = 0.38678 \text{ rad} \quad (8)$$

$$M_1 = E_1 - e \sin E_1 = 0.38678 - 0.30233 \cdot \sin 0.38678 = 0.27273 \text{ rad}$$

$$t_1 = \frac{M_1}{2\pi} T = \frac{0.27273}{2\pi} \cdot 9952.0 = 431.99 \text{ s}$$

Obtain  $E$  one hour later.

$$t_2 = t_1 + 3600 = 4032 \text{ s}$$

$$M_2 = 2\pi \frac{t_2}{T} = 2\pi \frac{4032}{9952.0} = 2.5456 \text{ rad}$$

$$E_2 - e \sin E_2 = M_2$$

$$E_2 - 0.30233 \sin E_2 = 2.5456$$

Using *Algorithm 3.1*,

$$E_2 = 2.6802 \text{ rad} \quad (9)$$

According to Equation 3.55,

$$\chi = \sqrt{a}(E_2 - E_1) = \sqrt{10000}(2.6802 - 0.38678) = \underline{229.34 \text{ km}^{1/2}}$$

This is the same as the value obtained via *Algorithm 3.3*

**Problem 3.19** Write the following MATLAB script to use the M-function `rv_from_r0v0` to execute *Algorithm 3.4*.

```
clear
global mu
mu = 398600;

R0 = [20000 -105000 -19000];
V0 = [ 0.9 -3.4 -1.5];
t = 2*3600;

[R V] = rv_from_r0v0(R0, V0, t);

fprintf('-----')
fprintf('\n Initial position vector (km):')
fprintf('\n r0 = (%g, %g, %g)\n', R0(1), R0(2), R0(3))
fprintf('\n Initial velocity vector (km/s):')
```

```
fprintf('\n v0 = (%g, %g, %g)', V0(1), V0(2), V0(3))
fprintf('\n\n Elapsed time = %g s\n',t)
fprintf('\n Final position vector (km):')
fprintf('\n r = (%g, %g, %g)\n', R(1), R(2), R(3))
fprintf('\n Final velocity vector (km/s):')
fprintf('\n v = (%g, %g, %g)', V(1), V(2), V(3))
fprintf('\n-----\n')
```

The output to the MATLAB Command Window is as follows:

```
-----
Initial position vector (km):
  r0 = (20000, -105000, -19000)

Initial velocity vector (km/s):
  v0 = (0.9, -3.4, -1.5)

Elapsed time = 7200 s

Final position vector (km):
  r = (26337.8, -128752, -29655.9)

Final velocity vector (km/s):
  v = (0.862796, -3.2116, -1.46129)
-----
```

---



**Problem 4.1** *Algorithm 4.1* (MATLAB M-function `coe_from_sv` in Appendix D.8):

- (1)  $r = \|\mathbf{r}\| = 16\,850 \text{ km}$
- (2)  $v = \|\mathbf{v}\| = 5.7415 \text{ km/s}$
- (3)  $v_r = \frac{\mathbf{r} \cdot \mathbf{v}}{r} = 0.0018856 \text{ km/s} \quad (> 0)$
- (4)  $\mathbf{h} = \mathbf{r} \times \mathbf{v} = 82\,234\hat{\mathbf{I}} - 23\,035\hat{\mathbf{J}} + 41\,876\hat{\mathbf{K}} \text{ (km}^2/\text{s)}$
- (5)  $h = \|\mathbf{h}\| = 95\,360 \text{ km}^2/\text{s}$
- (6)  $i = \cos^{-1}\left(\frac{h_Z}{h}\right) = \cos^{-1}\left(\frac{41\,876}{95\,360}\right) = 63.952^\circ$
- (7)  $\mathbf{N} = \hat{\mathbf{K}} \times \mathbf{h} = 24\,035\hat{\mathbf{I}} + 82\,234\hat{\mathbf{J}} \text{ (km}^2/\text{s)} \quad (N_Y > 0)$
- (8)  $N = \|\mathbf{N}\| = 85\,674 \text{ km}^2/\text{s}$
- (9)  $\Omega = \cos^{-1}\left(\frac{N_X}{N}\right) = \cos^{-1}\left(\frac{24\,035}{85\,674}\right) = 73.707^\circ$
- (10)  $\mathbf{e} = \frac{1}{398\,600} \left[ (5.7415^2 - 398\,600/16\,850)(2615\hat{\mathbf{I}} + 15\,881\hat{\mathbf{J}} + 3980\hat{\mathbf{K}}) \right. \\ \left. - (16\,580)(0.0018856)(-2.767\hat{\mathbf{I}} - 0.7905\hat{\mathbf{J}} + 4.98\hat{\mathbf{K}}) \right] \\ = 0.059521\hat{\mathbf{I}} + 0.36032\hat{\mathbf{J}} + 0.08988\hat{\mathbf{K}} \quad (e_Z > 0)$
- (11)  $e = \|\mathbf{e}\| = 0.37602$
- (12)  $\omega = \cos^{-1}\left(\frac{\mathbf{N} \cdot \mathbf{e}}{Ne}\right) = 15.43^\circ$
- (13)  $\theta = \cos^{-1}\left(\frac{\mathbf{e} \cdot \mathbf{r}}{er}\right) = 0.06742^\circ$

**Problem 4.2** *Algorithm 4.1* (MATLAB M-function `coe_from_sv` in Appendix D.8):

- (1)  $r = \|\mathbf{r}\| = 12\,670 \text{ km}$
- (2)  $v = \|\mathbf{v}\| = 3.9538 \text{ km/s}$
- (3)  $v_r = \frac{\mathbf{r} \cdot \mathbf{v}}{r} = -0.7905 \text{ km/s} \quad (< 0)$
- (4)  $\mathbf{h} = \mathbf{r} \times \mathbf{v} = 49\,084\hat{\mathbf{I}} \text{ (km}^2/\text{s)}$
- (5)  $h = \|\mathbf{h}\| = 49\,084 \text{ km}^2/\text{s}$
- (6)  $i = \cos^{-1}\left(\frac{h_Z}{h}\right) = \cos^{-1}\left(\frac{0}{49\,084}\right) = 90^\circ$
- (7)  $\mathbf{N} = \hat{\mathbf{K}} \times \mathbf{h} = 49\,084\hat{\mathbf{J}} \text{ (km}^2/\text{s)} \quad (N_Y > 0)$
- (8)  $N = \|\mathbf{N}\| = 49\,084 \text{ km}^2/\text{s}$
- (9)  $\Omega = \cos^{-1}\left(\frac{N_X}{N}\right) = \cos^{-1}\left(\frac{0}{49\,084}\right) = 90^\circ$
- (10)  $\mathbf{e} = \frac{1}{398\,600} \left[ (3.9538^2 - 398\,600/12\,670)(12\,670\hat{\mathbf{K}}) \right. \\ \left. - (12\,670)(-0.7905)(-3.874\hat{\mathbf{J}} - 0.7905\hat{\mathbf{K}}) \right] \\ = -0.097342\hat{\mathbf{J}} - 0.52296\hat{\mathbf{K}} \quad (e_Z < 0)$
- (11)  $e = \|\mathbf{e}\| = 0.53194$

$$(12) \quad \omega = 360^\circ - \cos^{-1}\left(\frac{\mathbf{N} \cdot \mathbf{e}}{Ne}\right) = 360^\circ - 100.54^\circ = \underline{259.46^\circ}$$

$$(13) \quad \theta = 360^\circ - \cos^{-1}\left(\frac{\mathbf{e} \cdot \mathbf{r}}{er}\right) = 360^\circ - 169.46^\circ = \underline{190.54^\circ}$$

**Problem 4.3** *Algorithm 4.1* (MATLAB M-function `coe_from_sv` in Appendix D.8):

$$(1) \quad \|\mathbf{r}\| = 10189 \text{ km}$$

$$(2) \quad \|\mathbf{v}\| = 5.8805 \text{ km/s}$$

$$(3) \quad v_r = \frac{\mathbf{r} \cdot \mathbf{v}}{r} = 1.2874 \text{ km/s} \quad (> 0)$$

$$(4) \quad \mathbf{h} = \mathbf{r} \times \mathbf{v} = 31509\hat{\mathbf{i}} + 11468\hat{\mathbf{j}} + 47888\hat{\mathbf{k}} \quad (\text{km}^2/\text{s})$$

$$(5) \quad h = \|\mathbf{h}\| = \underline{58461 \text{ km}^2/\text{s}}$$

$$(6) \quad i = \cos^{-1}\left(\frac{h_z}{h}\right) = \cos^{-1}\left(\frac{47888}{58461}\right) = \underline{35^\circ}$$

$$(7) \quad \mathbf{N} = \hat{\mathbf{K}} \times \mathbf{h} = -11468\hat{\mathbf{i}} + 31509\hat{\mathbf{j}} \quad (\text{km}^2/\text{s}) \quad (N_Y > 0)$$

$$(8) \quad N = \|\mathbf{N}\| = 33532 \text{ km}^2/\text{s}$$

$$(9) \quad \Omega = \cos^{-1}\left(\frac{N_x}{N}\right) = \cos^{-1}\left(\frac{-11468}{33532}\right) = \underline{110^\circ}$$

$$(10) \quad \mathbf{e} = \frac{1}{398600} \left[ \left( 5.8805^2 - 398600/10189 \right) (6472.7\hat{\mathbf{i}} - 7470.8\hat{\mathbf{j}} - 2469.8\hat{\mathbf{k}}) \right. \\ \left. - (10189)(1.2874) (3.9914\hat{\mathbf{i}} + 2.7916\hat{\mathbf{j}} - 3.2948\hat{\mathbf{k}}) \right] \\ = -0.2051\hat{\mathbf{i}} - 0.0067382\hat{\mathbf{j}} + 0.13657\hat{\mathbf{k}} \quad (e_z > 0)$$

$$(11) \quad e = \|\mathbf{e}\| = \underline{0.2465}$$

$$(12) \quad \omega = \cos^{-1}\left(\frac{\mathbf{N} \cdot \mathbf{e}}{Ne}\right) = \underline{74.996^\circ}$$

$$(13) \quad \theta = \cos^{-1}\left(\frac{\mathbf{e} \cdot \mathbf{r}}{er}\right) = \underline{130^\circ}$$

**Problem 4.4**

$$v_r = \frac{\mathbf{v} \cdot \mathbf{r}}{r} = -2.30454 \text{ km/s} \quad (\text{Flying towards perigee})$$

$$\theta = 360^\circ - \cos^{-1}\left(\frac{\mathbf{e} \cdot \mathbf{r}}{er}\right) = 360^\circ - 30^\circ = \underline{330^\circ}$$

**Problem 4.5**

$$\hat{\mathbf{w}} = \frac{\mathbf{r} \times \mathbf{e}}{\|\mathbf{r} \times \mathbf{e}\|} = \frac{-3353.1\hat{\mathbf{i}} + 6361.8\hat{\mathbf{j}} + 2718.1\hat{\mathbf{k}}}{7687.9}$$

$$\hat{\mathbf{w}} = -0.43616\hat{\mathbf{i}} + 0.82751\hat{\mathbf{j}} + 0.35355\hat{\mathbf{k}}$$

$$i = \cos^{-1}(\hat{\mathbf{w}} \cdot \hat{\mathbf{K}}) = \cos^{-1}(0.35355) = \underline{69.295^\circ}$$

**Problem 4.6**

(a)

$$\vec{AB} = (4-1)\hat{\mathbf{i}} + (6-2)\hat{\mathbf{j}} + (5-3)\hat{\mathbf{k}} = 3\hat{\mathbf{i}} + 4\hat{\mathbf{j}} + 2\hat{\mathbf{k}}$$

$$\vec{AC} = (3-1)\hat{\mathbf{i}} + (9-2)\hat{\mathbf{j}} + (-2-3)\hat{\mathbf{k}} = 2\hat{\mathbf{i}} + 7\hat{\mathbf{j}} - 5\hat{\mathbf{k}}$$

$$\mathbf{X}' = \vec{AB} = 3\hat{\mathbf{i}} + 4\hat{\mathbf{j}} + 2\hat{\mathbf{k}}$$

$$\mathbf{Z}' = \mathbf{X}' \times \vec{AC} = -34\hat{\mathbf{i}} + 19\hat{\mathbf{j}} + 13\hat{\mathbf{k}}$$

$$\mathbf{Y}' = \mathbf{Z}' \times \mathbf{X}' = -14\hat{\mathbf{i}} + 107\hat{\mathbf{j}} - 193\hat{\mathbf{k}}$$

$$\hat{\mathbf{i}}' = \frac{\mathbf{X}'}{\|\mathbf{X}'\|} = 0.55709\hat{\mathbf{i}} + 0.74278\hat{\mathbf{j}} + 0.37139\hat{\mathbf{k}}$$

$$\hat{\mathbf{j}}' = \frac{\mathbf{Y}'}{\|\mathbf{Y}'\|} = -0.063314\hat{\mathbf{i}} + 0.48390\hat{\mathbf{j}} - 0.87283\hat{\mathbf{k}}$$

$$\hat{\mathbf{k}}' = \frac{\mathbf{Z}'}{\|\mathbf{Z}'\|} = -0.82804\hat{\mathbf{i}} + 0.46273\hat{\mathbf{j}} + 0.31660\hat{\mathbf{k}}$$

$$[\mathbf{Q}] = \begin{Bmatrix} [\hat{\mathbf{i}}'] \\ [\hat{\mathbf{j}}'] \\ [\hat{\mathbf{k}}'] \end{Bmatrix} = \begin{bmatrix} 0.55709 & 0.74278 & 0.37139 \\ -0.063314 & 0.48390 & -0.87283 \\ -0.82804 & 0.46273 & 0.31660 \end{bmatrix}$$

(b)

$$\{\mathbf{v}\} = [\mathbf{Q}]^T \{\mathbf{v}'\} = \begin{bmatrix} 0.55709 & -0.063314 & -0.82804 \\ 0.74278 & 0.48390 & 0.46273 \\ 0.37139 & -0.87283 & 0.31660 \end{bmatrix} \begin{Bmatrix} 2 \\ -1 \\ 3 \end{Bmatrix}$$

$$\{\mathbf{v}\} = \begin{Bmatrix} -1.3066 \\ 2.3898 \\ 2.5654 \end{Bmatrix} \quad (\mathbf{v} = -1.3066\hat{\mathbf{i}} + 2.3898\hat{\mathbf{j}} + 2.5654\hat{\mathbf{k}})$$

**Problem 4.7**

$$\{\mathbf{V}\}_u = [\mathbf{Q}]_{xu} \{\mathbf{V}\}_x = \begin{bmatrix} 0.26726 & 0.53452 & 0.80178 \\ -0.44376 & 0.80684 & -0.38997 \\ -0.85536 & -0.25158 & 0.45284 \end{bmatrix} \begin{Bmatrix} -50 \\ 100 \\ 75 \end{Bmatrix}$$

$$\{\mathbf{V}\}_u = \begin{Bmatrix} 100.22 \\ 73.624 \\ 51.573 \end{Bmatrix} \quad (\mathbf{V} = 100.22\hat{\mathbf{u}} + 73.624\hat{\mathbf{v}} + 51.573\hat{\mathbf{w}})$$

**Problem 4.8**

$$[\mathbf{R}_1] = \begin{bmatrix} 1 & 0 & 0 \\ 0 & \cos 40^\circ & \sin 40^\circ \\ 0 & -\sin 40^\circ & \cos 40^\circ \end{bmatrix} \quad [\mathbf{R}_2] = \begin{bmatrix} \cos 25^\circ & 0 & -\sin 25^\circ \\ 0 & 1 & 0 \\ \sin 25^\circ & 0 & \cos 25^\circ \end{bmatrix}$$

$$[\mathbf{Q}] = [\mathbf{R}_2][\mathbf{R}_1] = \begin{bmatrix} \cos 25^\circ & \sin 40^\circ \sin 25^\circ & -\cos 40^\circ \sin 25^\circ \\ 0 & \cos 40^\circ & \sin 40^\circ \\ \sin 25^\circ & -\sin 40^\circ \cos 25^\circ & \cos 40^\circ \cos 25^\circ \end{bmatrix}$$

$$[\mathbf{Q}] = \begin{bmatrix} 0.90631 & 0.27165 & -0.32374 \\ 0 & 0.76604 & 0.64279 \\ 0.42262 & -0.58256 & 0.69427 \end{bmatrix}$$

**Problem 4.9**  $\mathbf{r}_o = -5102\hat{\mathbf{i}} - 8228\hat{\mathbf{j}} - 2106\hat{\mathbf{k}}$  (km)  $\mathbf{v}_o = -4.348\hat{\mathbf{i}} + 3.478\hat{\mathbf{j}} - 2.846\hat{\mathbf{k}}$  (km/s)

Method 1



Use *Algorithm 3.4* (MATLAB M-function `rv_from_r0v0` in Appendix D.7):

$$\begin{aligned}
 (1a) \quad & r_o = 9907.6 \text{ km} \quad v_o = 6.2531 \text{ km/s} \\
 (1b) \quad & v_{r_o} = -0.044678 \text{ km/s} \\
 (1c) \quad & \alpha = 103.77 \times 10^{-6} \text{ km}^{-1} \\
 (2) \quad & \chi = 195 \text{ km}^{1/2} \\
 (3) \quad & f = -0.36539 \quad g = 1394.4 \text{ s}^{-1} \\
 (4) \quad & \mathbf{r} = (-0.36539) \begin{pmatrix} -5102\hat{\mathbf{I}} - 8228\hat{\mathbf{J}} - 2106\hat{\mathbf{K}} \end{pmatrix} + 1394.4 \begin{pmatrix} -4.348\hat{\mathbf{I}} + 3.478\hat{\mathbf{J}} - 2.846\hat{\mathbf{K}} \end{pmatrix} \\
 & = \underline{-4198.4\hat{\mathbf{I}} + 7856.1\hat{\mathbf{J}} - 3199.2\hat{\mathbf{K}} \text{ (km)}} \\
 (5) \quad & \dot{f} = -6.0467 \times 10^{-4} \text{ s}^{-1} \quad \dot{g} = -0.42931 \\
 (6) \quad & \mathbf{v} = (-6.0467 \times 10^{-4}) \begin{pmatrix} -5102\hat{\mathbf{I}} - 8228\hat{\mathbf{J}} - 2106\hat{\mathbf{K}} \end{pmatrix} + (-0.42931) \begin{pmatrix} -4.348\hat{\mathbf{I}} + 3.478\hat{\mathbf{J}} - 2.846\hat{\mathbf{K}} \end{pmatrix} \\
 & = \underline{4.9517\hat{\mathbf{I}} + 3.4821\hat{\mathbf{J}} + 2.4946\hat{\mathbf{K}} \text{ (km/s)}}
 \end{aligned}$$

*Method 2*

Compute the orbital elements using *Algorithm 4.1* (MATLAB M-function `coe_from_sv` in Appendix D.8):

$$\begin{aligned}
 (1) \quad & r = \|\mathbf{r}\| = 9907.6 \text{ km} \\
 (2) \quad & v = \|\mathbf{v}\| = 6.2531 \text{ km/s} \\
 (3) \quad & v_r = \frac{\mathbf{r} \cdot \mathbf{v}}{r} = -0.044678 \text{ km/s} \quad (< 0) \\
 (4) \quad & \mathbf{h} = \mathbf{r} \times \mathbf{v} = 30738\hat{\mathbf{I}} - 5367.8\hat{\mathbf{J}} - 53520\hat{\mathbf{K}} \text{ (km}^2/\text{s)} \\
 (5) \quad & h = \|\mathbf{h}\| = \underline{61\,952 \text{ km}^2/\text{s}} \\
 (6) \quad & i = \cos^{-1} \left( \frac{h_Z}{h} \right) = \cos^{-1} \left( \frac{-53520}{61\,952} \right) = \underline{149.76^\circ} \\
 (7) \quad & \mathbf{N} = \hat{\mathbf{K}} \times \mathbf{h} = 5367.8\hat{\mathbf{I}} + 30738\hat{\mathbf{J}} \text{ (km}^2/\text{s)} \quad (N_Y > 0) \\
 (8) \quad & N = \|\mathbf{N}\| = 31\,203 \text{ km}^2/\text{s} \\
 (9) \quad & \Omega = \cos^{-1} \left( \frac{N_X}{N} \right) = \cos^{-1} \left( \frac{5367.8}{31\,203} \right) = \underline{80.094^\circ} \\
 (10) \quad & \mathbf{e} = \frac{1}{398\,600} \left[ \left( 5.7415^2 - 398\,600/9907.6 \right) \begin{pmatrix} -5102\hat{\mathbf{I}} - 8228\hat{\mathbf{J}} - 2106\hat{\mathbf{K}} \end{pmatrix} \right. \\
 & \quad \left. - (9907.6)(-0.044678) \begin{pmatrix} -4.348\hat{\mathbf{I}} + 3.478\hat{\mathbf{J}} - 2.846\hat{\mathbf{K}} \end{pmatrix} \right] \\
 & = 0.00963851\hat{\mathbf{I}} + 0.027193\hat{\mathbf{J}} + 0.0028083\hat{\mathbf{K}} \quad (e_Z > 0) \\
 (11) \quad & e = \|\mathbf{e}\| = \underline{0.028987} \\
 (12) \quad & \omega = \cos^{-1} \left( \frac{\mathbf{N} \cdot \mathbf{e}}{Ne} \right) = \underline{11.09^\circ} \\
 (13) \quad & \theta = 360^\circ - \cos^{-1} \left( \frac{\mathbf{e} \cdot \mathbf{r}}{er} \right) = 360^\circ - 166.14^\circ = \underline{193.86^\circ} \\
 & T = \frac{2\pi}{\mu^2} \left( \frac{h}{\sqrt{1-e^2}} \right)^3 = 9414.9 \text{ s}
 \end{aligned}$$

Determine the time since perigee passage at true anomaly  $\theta_o = 193.86^\circ$  :

$$\tan \frac{E_o}{2} = \sqrt{\frac{1-e}{1+e}} \tan \frac{\theta_o}{2} = \sqrt{\frac{1-0.028987}{1+0.028987}} \tan \frac{193.86^\circ}{2} \Rightarrow E_o = -2.8926 \text{ rad}$$

$$M_o = E_o - e \sin E_o = -2.8926 - 0.028987 \cdot \sin(-2.8926) = -2.8855 \text{ rad}$$

$$t_o = \frac{M_o}{2\pi} T = \frac{-2.8855}{2\pi} 9414.9 = -4323.7 \text{ s (minus means time until perigee passage)}$$

Update the true anomaly of the spacecraft.  $t = t_o + 50 \cdot 60 = -1323.7 \text{ s}$ .

$$M = 2\pi \frac{t}{T} = 2\pi \frac{-1323.7}{9414.9} = -0.88341 \text{ rad}$$

$$E - e \sin E = M$$

$$E - 0.028987 \sin E = -0.88341 \Rightarrow E = -0.90623 \text{ rad (Algorithm 3.1)}$$

$$\tan \frac{\theta}{2} = \sqrt{\frac{1+e}{1-e}} \tan \frac{E}{2} = \sqrt{\frac{1+0.028987}{1-0.028987}} \tan \frac{-0.90623}{2} \Rightarrow \theta = -53.242^\circ$$

Algorithm 4.2 (MATLAB M-function `sv_from_coe` in Appendix D.9):

$$(1) \quad \{\mathbf{r}\}_{\bar{x}} = \frac{h^2}{\mu} \frac{1}{1+e \cos \theta} \begin{Bmatrix} \cos \theta \\ \sin \theta \\ 0 \end{Bmatrix} = \frac{61\,952^2}{398\,600} \frac{1}{1+0.028987 \cos(-53.242^\circ)} \begin{Bmatrix} \cos(-53.242^\circ) \\ \sin(-53.242^\circ) \\ 0 \end{Bmatrix}$$

$$= \begin{Bmatrix} 5663.9 \\ -7582.8 \\ 0 \end{Bmatrix} \text{ (km)}$$

$$(2) \quad \{\mathbf{v}\}_{\bar{x}} = \frac{\mu}{h} \begin{Bmatrix} -\sin \theta \\ e + \cos \theta \\ 0 \end{Bmatrix} = \frac{398\,600}{61\,952} \begin{Bmatrix} -\sin(-53.242^\circ) \\ 0.028987 + \cos(-53.242^\circ) \\ 0 \end{Bmatrix} = \begin{Bmatrix} 5.1548 \\ 4.0368 \\ 0 \end{Bmatrix} \text{ (km/s)}$$

$$(3) \quad [\mathbf{Q}]_{\bar{x}X} = \begin{bmatrix} \cos \Omega \cos \omega - \sin \Omega \sin \omega \cos i & -\cos \Omega \sin \omega - \sin \Omega \cos i \cos \omega & \sin \Omega \sin i \\ \sin \Omega \cos \omega + \cos \Omega \cos i \sin \omega & -\sin \Omega \sin \omega + \cos \Omega \cos i \cos \omega & -\cos \Omega \sin i \\ \sin i \sin \omega & \sin i \cos \omega & \cos i \end{bmatrix}$$

$$= \begin{bmatrix} 0.33251 & 0.80204 & 0.49616 \\ 0.93811 & -0.33532 & -0.086644 \\ 0.09688 & 0.49426 & -0.8639 \end{bmatrix}$$

$$(4) \quad \{\mathbf{r}\}_X = [\mathbf{Q}]_{\bar{x}X} \{\mathbf{r}\}_{\bar{x}} = \begin{Bmatrix} -4198.4 \\ 7856.1 \\ -3199.2 \end{Bmatrix} \text{ (km) or } \underline{\mathbf{r} = -4198.4\hat{\mathbf{I}} + 7856.1\hat{\mathbf{J}} - 3199.2\hat{\mathbf{K}} \text{ (km)}}$$

$$\{\mathbf{v}\}_X = [\mathbf{Q}]_{\bar{x}X} \{\mathbf{v}\}_{\bar{x}} = \begin{Bmatrix} 4.9517 \\ 3.4821 \\ 2.4946 \end{Bmatrix} \text{ (km/s) or } \underline{\mathbf{v} = 4.9517\hat{\mathbf{I}} + 3.4821\hat{\mathbf{J}} + 2.4946\hat{\mathbf{K}} \text{ (km/s)}}$$

**Problem 4.10**  $e = 1.5$   $\Omega = 130^\circ$   $i = 35^\circ$   $\omega = 115^\circ$   $\theta = 0^\circ$   $r_{\text{perigee}} = 6678 \text{ km}$

$$h = \sqrt{\mu(1+e)r_{\text{perigee}}} = \sqrt{398\,600 \cdot (1+1.5) \cdot 6678} = 81\,576 \text{ km}^2/\text{s}$$

Algorithm 4.2 (MATLAB M-function `sv_from_coe` in Appendix D.9):

$$(1) \{\mathbf{r}\}_{\bar{x}} = \frac{h^2}{\mu} \frac{1}{1 + e \cos \theta} \begin{Bmatrix} \cos \theta \\ \sin \theta \\ 0 \end{Bmatrix} = \frac{81576^2}{398600} \frac{1}{1 + 1.5 \cos(0)} \begin{Bmatrix} \cos(0) \\ \sin(0) \\ 0 \end{Bmatrix} = \begin{Bmatrix} 6678 \\ 0 \\ 0 \end{Bmatrix} \text{ (km)}$$

$$\mathbf{r} = 6678\hat{\mathbf{p}} \text{ (km)}$$

$$(2) \{\mathbf{v}\}_{\bar{x}} = \frac{\mu}{h} \begin{Bmatrix} -\sin \theta \\ e + \cos \theta \\ 0 \end{Bmatrix} = \frac{398600}{81576} \begin{Bmatrix} -\sin(0) \\ 1.5 + \cos(0) \\ 0 \end{Bmatrix} = \begin{Bmatrix} 0 \\ 12.216 \\ 0 \end{Bmatrix} \text{ (km/s)}$$

$$\mathbf{v} = 12.216\hat{\mathbf{q}} \text{ (km/s)}$$

$$(3) [\mathbf{Q}]_{\bar{x}X} = \begin{bmatrix} \cos \Omega \cos \omega - \sin \Omega \sin \omega \cos i & -\cos \Omega \sin \omega - \sin \Omega \cos i \cos \omega & \sin \Omega \sin i \\ \sin \Omega \cos \omega + \cos \Omega \cos i \sin \omega & -\sin \Omega \sin \omega + \cos \Omega \cos i \cos \omega & -\cos \Omega \sin i \\ \sin i \sin \omega & \sin i \cos \omega & \cos i \end{bmatrix}$$

$$= \begin{bmatrix} -0.29706 & 0.84776 & 0.43939 \\ -0.80095 & -0.47175 & 0.36869 \\ 0.51984 & -0.2424 & 0.81915 \end{bmatrix}$$

$$(4) \{\mathbf{r}\}_X = [\mathbf{Q}]_{\bar{x}X} \{\mathbf{r}\}_{\bar{x}} = \begin{Bmatrix} -1983.8 \\ -5348.8 \\ 3471.5 \end{Bmatrix} \text{ (km)} \quad \text{or} \quad \mathbf{r} = -1983.8\hat{\mathbf{I}} - 5348.8\hat{\mathbf{J}} + 3471.5\hat{\mathbf{K}} \text{ (km)}$$

$$\{\mathbf{v}\}_X = [\mathbf{Q}]_{\bar{x}X} \{\mathbf{v}\}_{\bar{x}} = \begin{Bmatrix} 10.356 \\ -5.7627 \\ -2.9611 \end{Bmatrix} \text{ (km/s)} \quad \text{or} \quad \mathbf{v} = 10.356\hat{\mathbf{I}} - 5.7627\hat{\mathbf{J}} - 2.9611\hat{\mathbf{K}} \text{ (km/s)}$$

**Problem 4.11**  $h = 81576 \text{ km}^2/\text{s}$   $e = 1.5$   $\Omega = 130^\circ$   $i = 35^\circ$   $\omega = 115^\circ$ .

$$t = 7200 \text{ s}$$

$$M_h = \frac{\mu^2}{h^3} (e^2 - 1)^{3/2} t = \frac{398600^2}{81576^3} (1.5^2 - 1)^{3/2} \cdot 7200 = 2.945$$

$$e \sinh F - F = M_h$$

$$1.5 \sinh F - F = 2.945 \Rightarrow F = 1.886 \text{ (Algorithm 3.2)}$$

$$\tan \frac{\theta}{2} = \sqrt{\frac{e+1}{e-1}} \tanh \frac{F}{2} = \sqrt{\frac{1.5+1}{1.5-1}} \tanh \frac{1.886}{2} \Rightarrow \theta = 117.47^\circ$$

Algorithm 4.2 (MATLAB M-function `sv_from_coe` in Appendix D.9):

$$(1) \{\mathbf{r}\}_{\bar{x}} = \frac{h^2}{\mu} \frac{1}{1 + e \cos \theta} \begin{Bmatrix} \cos \theta \\ \sin \theta \\ 0 \end{Bmatrix} = \frac{81576^2}{398600} \frac{1}{1 + 1.5 \cos(117.47^\circ)} \begin{Bmatrix} \cos(117.47^\circ) \\ \sin(117.47^\circ) \\ 0 \end{Bmatrix} = \begin{Bmatrix} -25007 \\ 48093 \\ 0 \end{Bmatrix} \text{ (km)}$$

$$\mathbf{r} = -25007\hat{\mathbf{p}} + 48093\hat{\mathbf{q}} \text{ (km)}$$

$$(2) \{\mathbf{v}\}_{\bar{x}} = \frac{\mu}{h} \begin{Bmatrix} -\sin \theta \\ e + \cos \theta \\ 0 \end{Bmatrix} = \frac{398600}{81576} \begin{Bmatrix} -\sin(117.47^\circ) \\ 1.5 + \cos(117.47^\circ) \\ 0 \end{Bmatrix} = \begin{Bmatrix} -4.3352 \\ 5.0752 \\ 0 \end{Bmatrix} \text{ (km/s)}$$

$$\mathbf{v} = -4.3352\hat{\mathbf{p}} + 5.0752\hat{\mathbf{q}} \text{ (km/s)}$$

$$(3) \quad [\mathbf{Q}]_{\bar{x}X} = \begin{bmatrix} -0.29706 & 0.84776 & 0.43939 \\ -0.80095 & -0.47175 & 0.36869 \\ 0.51984 & -0.2424 & 0.81915 \end{bmatrix} \quad (\text{Problem 4.10})$$

$$(4) \quad \{\mathbf{r}\}_X = [\mathbf{Q}]_{\bar{x}X} \{\mathbf{r}\}_{\bar{x}} = \begin{bmatrix} 48200 \\ -2658 \\ -24658 \end{bmatrix} \quad (\text{km}) \quad \text{or} \quad \underline{\mathbf{r} = 48200\hat{\mathbf{I}} - 2658\hat{\mathbf{J}} - 24658\hat{\mathbf{K}} \quad (\text{km})}$$

$$\{\mathbf{v}\}_X = [\mathbf{Q}]_{\bar{x}X} \{\mathbf{v}\}_{\bar{x}} = \begin{bmatrix} 5.5903 \\ 1.0781 \\ -3.4838 \end{bmatrix} \quad (\text{km/s}) \quad \text{or} \quad \underline{\mathbf{v} = 5.5903\hat{\mathbf{I}} + 1.0781\hat{\mathbf{J}} - 3.4838\hat{\mathbf{K}} \quad (\text{km/s})}$$

**Problem 4.12**  $\mathbf{r}_o = 6472.7\hat{\mathbf{I}} - 7470.8\hat{\mathbf{J}} - 2469.8\hat{\mathbf{K}} \quad (\text{km}) \quad \mathbf{v}_o = 3.9914\hat{\mathbf{I}} + 2.7916\hat{\mathbf{J}} - 3.2948\hat{\mathbf{K}} \quad (\text{km/s}^2)$

*Method 1*

Use *Algorithm 3.4* (MATLAB M-function `rv_from_r0v0` in Appendix D.7):

$$(1a) \quad r_o = 10189 \text{ km} \quad v_o = 5.805 \text{ km/s}$$

$$(1b) \quad v_{r_o} = 1.2874 \text{ km/s}$$

$$(1c) \quad \alpha = 109.54 \times 10^{-6} \text{ km}^{-1}$$

$$(2) \quad \chi = 171.31 \text{ km}^{1/2}$$

$$(3) \quad f = -0.093379 \quad g = 1870.6 \text{ s}^{-1}$$

$$(4) \quad \mathbf{r} = (-0.093379)(6472.7\hat{\mathbf{I}} - 7470.8\hat{\mathbf{J}} - 2469.8\hat{\mathbf{K}}) + 1870.6(3.9914\hat{\mathbf{I}} + 2.7916\hat{\mathbf{J}} - 3.2948\hat{\mathbf{K}}) \\ = \underline{6861.9\hat{\mathbf{I}} + 5919.6\hat{\mathbf{J}} - 5932.7\hat{\mathbf{K}} \quad (\text{km})}$$

$$(5) \quad \dot{f} = -5.3316 \times 10^{-4} \text{ s}^{-1} \quad \dot{g} = -0.028475$$

$$(6) \quad \mathbf{v} = (-5.3316 \times 10^{-4})(6472.7\hat{\mathbf{I}} - 7470.8\hat{\mathbf{J}} - 2469.8\hat{\mathbf{K}}) + (-0.028475)(3.9914\hat{\mathbf{I}} + 2.7916\hat{\mathbf{J}} - 3.2948\hat{\mathbf{K}}) \\ = \underline{-3.5647\hat{\mathbf{I}} + 3.9037\hat{\mathbf{J}} + 1.4106\hat{\mathbf{K}} \quad (\text{km/s})}$$

*Method 2*

From Problem 4.3  $h = 58461 \text{ km}^2/\text{s}$ ,  $e = 0.2465$ ,  $i = 35^\circ$ ,  $\Omega = 110^\circ$ ,  $\omega = 74.996^\circ$ ,  $\theta = 130^\circ$ .

$$T = \frac{2\pi}{\mu^2} \left( \frac{h}{\sqrt{1-e^2}} \right)^3 = \frac{2\pi}{398600^2} \left( \frac{58461}{\sqrt{1-0.2465^2}} \right)^3 = 8680.3 \text{ s}$$

$$\tan \frac{E_o}{2} = \sqrt{\frac{1-e}{1+e}} \tan \frac{\theta_o}{2} = \sqrt{\frac{1-0.2465}{1+0.2465}} \tan \frac{130^\circ}{2} \Rightarrow E_o = 2.0612 \text{ rad}$$

$$M_o = E_o - e \sin E_o = 2.0612 - 0.2465 \cdot \sin(2.0612) = 1.8437 \text{ rad}$$

$$t_o = \frac{M_o}{2\pi} T = \frac{1.8437}{2\pi} 8680.3 = 2547.1 \text{ s} \quad (\text{minus means time until perigee passage})$$

Update the true anomaly:  $t = t_o + 50 \cdot 60 = 5547.1 \text{ s}$

$$M = 2\pi \frac{t}{T} = 2\pi \frac{5547.1}{8680.3} = 4.0153 \text{ rad}$$

$$E - e \sin E = M$$

$$E - 0.2465 \sin E = 4.0153 \Rightarrow E = 3.8541 \text{ rad (Algorithm 3.1)}$$

$$\tan \frac{\theta}{2} = \sqrt{\frac{1+e}{1-e}} \tan \frac{E}{2} = \sqrt{\frac{1+0.2465}{1-0.2465}} \tan \frac{3.8541}{2} \Rightarrow \theta = -147.73^\circ$$

Algorithm 4.2 (MATLAB M-function `sv_from_coe` in Appendix D.9):

$$(1) \quad \{\mathbf{r}\}_{\bar{x}} = \frac{h^2}{\mu} \frac{1}{1+e \cos \theta} \begin{Bmatrix} \cos \theta \\ \sin \theta \\ 0 \end{Bmatrix} = \frac{58461^2}{398600} \frac{1}{1+0.2465 \cos(-147.73^\circ)} \begin{Bmatrix} \cos(-147.73^\circ) \\ \sin(-147.73^\circ) \\ 0 \end{Bmatrix}$$

$$= \begin{Bmatrix} -9158.1 \\ -5783.8 \\ 0 \end{Bmatrix} \text{ (km)}$$

$$(2) \quad \{\mathbf{v}\}_{\bar{x}} = \frac{\mu}{h} \begin{Bmatrix} -\sin \theta \\ e + \cos \theta \\ 0 \end{Bmatrix} = \frac{398600}{8461} \begin{Bmatrix} -\sin(-147.73^\circ) \\ 0.2465 + \cos(-147.73^\circ) \\ 0 \end{Bmatrix} = \begin{Bmatrix} 3.6408 \\ -4.0841 \\ 0 \end{Bmatrix} \text{ (km/s)}$$

$$(3) \quad [\mathbf{Q}]_{\bar{x}X} = \begin{bmatrix} \cos \Omega \cos \omega - \sin \Omega \sin \omega \cos i & -\cos \Omega \sin \omega - \sin \Omega \cos i \cos \omega & \sin \Omega \sin i \\ \sin \Omega \cos \omega + \cos \Omega \cos i \sin \omega & -\sin \Omega \sin \omega + \cos \Omega \cos i \cos \omega & -\cos \Omega \sin i \\ \sin i \sin \omega & \sin i \cos \omega & \cos i \end{bmatrix}$$

$$= \begin{bmatrix} -0.8321 & 0.13078 & 0.53899 \\ -0.026991 & -0.9802 & 0.19617 \\ 0.55397 & 0.14869 & 0.81915 \end{bmatrix}$$

$$(4) \quad \{\mathbf{r}\}_X = [\mathbf{Q}]_{\bar{x}X} \{\mathbf{r}\}_{\bar{x}} = \begin{Bmatrix} 6864 \\ 5916.5 \\ -5933.3 \end{Bmatrix} \text{ (km)} \quad \text{or} \quad \mathbf{r} = 6864\hat{\mathbf{I}} + 5916.5\hat{\mathbf{J}} - 5933.3\hat{\mathbf{K}} \text{ (km)}$$

$$\{\mathbf{v}\}_X = [\mathbf{Q}]_{\bar{x}X} \{\mathbf{v}\}_{\bar{x}} = \begin{Bmatrix} -3.5636 \\ 3.905 \\ 1.4096 \end{Bmatrix} \text{ (km/s)} \quad \text{or} \quad \mathbf{v} = -3.5636\hat{\mathbf{I}} + 3.905\hat{\mathbf{J}} + 1.4096\hat{\mathbf{K}} \text{ (km/s)}$$

**Problem 4.13**  $e = 1.2$   $\Omega = 75^\circ$   $i = 50^\circ$   $\omega = 80^\circ$   $\theta = 0^\circ$   $r_{\text{perigee}} = 6578 \text{ km}$

$$h = \sqrt{\mu(1+e)r_{\text{perigee}}} = \sqrt{398600 \cdot (1+1.2) \cdot 6578} = 79950 \text{ km}^2/\text{s}$$

Algorithm 4.2 (MATLAB M-function `sv_from_coe` in Appendix D.9):

$$(1) \quad \{\mathbf{r}\}_{\bar{x}} = \frac{h^2}{\mu} \frac{1}{1+e \cos \theta} \begin{Bmatrix} \cos \theta \\ \sin \theta \\ 0 \end{Bmatrix} = \frac{79950^2}{398600} \frac{1}{1+1.2 \cos(0)} \begin{Bmatrix} \cos(0) \\ \sin(0) \\ 0 \end{Bmatrix} = \begin{Bmatrix} 6578 \\ 0 \\ 0 \end{Bmatrix} \text{ (km)}$$

$$\mathbf{r} = 6578\hat{\mathbf{p}} \text{ (km)}$$

$$(2) \quad \{\mathbf{v}\}_{\bar{x}} = \frac{\mu}{h} \begin{Bmatrix} -\sin \theta \\ e + \cos \theta \\ 0 \end{Bmatrix} = \frac{398600}{79950} \begin{Bmatrix} -\sin(0) \\ 1.2 + \cos(0) \\ 0 \end{Bmatrix} = \begin{Bmatrix} 0 \\ 11.546 \\ 0 \end{Bmatrix} \text{ (km/s)}$$

$$\mathbf{v} = 11.546\hat{\mathbf{q}} \text{ (km/s)}$$

$$(3) \quad [\mathbf{Q}]_{\bar{x}X} = \begin{bmatrix} \cos \Omega \cos \omega - \sin \Omega \sin \omega \cos i & -\cos \Omega \sin \omega - \sin \Omega \cos i \cos \omega & \sin \Omega \sin i \\ \sin \Omega \cos \omega + \cos \Omega \cos i \sin \omega & -\sin \Omega \sin \omega + \cos \Omega \cos i \cos \omega & -\cos \Omega \sin i \\ \sin i \sin \omega & \sin i \cos \omega & \cos i \end{bmatrix}$$

$$= \begin{bmatrix} -0.56561 & -0.3627 & 0.73994 \\ 0.33157 & -0.92236 & -0.19827 \\ 0.75441 & 0.13302 & 0.64279 \end{bmatrix}$$

$$(4) \quad \{\mathbf{r}\}_X = [\mathbf{Q}]_{\bar{x}X} \{\mathbf{r}\}_{\bar{x}} = \begin{bmatrix} -3726.5 \\ 2181.1 \\ 4962.5 \end{bmatrix} \text{ (km)} \quad \text{or} \quad \underline{\mathbf{r} = -3726.5\hat{\mathbf{I}} + 2181.1\hat{\mathbf{J}} + 4962.5\hat{\mathbf{K}} \text{ (km)}}$$

$$\{\mathbf{v}\}_X = [\mathbf{Q}]_{\bar{x}X} \{\mathbf{v}\}_{\bar{x}} = \begin{bmatrix} -4.1878 \\ -10.65 \\ 1.5359 \end{bmatrix} \text{ (km/s)} \quad \text{or} \quad \underline{\mathbf{v} = -4.1878\hat{\mathbf{I}} + 10.65\hat{\mathbf{J}} + 1.5359\hat{\mathbf{K}} \text{ (km/s)}}$$

**Problem 4.14**  $h = 75950 \text{ km}^2/\text{s}$   $e = 1.2$   $\Omega = 130^\circ$   $i = 50^\circ$   $\omega = 80^\circ$

$$t = 7200 \text{ s}$$

$$M_h = \frac{\mu^2}{h^3} (e^2 - 1)^{3/2} t = \frac{398600^2}{75950^3} (1.2^2 - 1)^{3/2} \cdot 7200 = 0.76209$$

$$e \sinh F - F = M_h$$

$$1.2 \sinh F - F = 0.76209 \Rightarrow F = 1.3174 \text{ (Algorithm 3.2)}$$

$$\tan \frac{\theta}{2} = \sqrt{\frac{e+1}{e-1}} \tanh \frac{F}{2} = \sqrt{\frac{1.2+1}{1.2-1}} \tanh \frac{1.3174}{2} \Rightarrow \theta = 124.86^\circ$$

Algorithm 4.2 (MATLAB M-function `sv_from_coe` in Appendix D.9):

$$(1) \quad \{\mathbf{r}\}_{\bar{x}} = \frac{h^2}{\mu} \frac{1}{1 + e \cos \theta} \begin{bmatrix} \cos \theta \\ \sin \theta \\ 0 \end{bmatrix} = \frac{75950^2}{398600} \frac{1}{1 + 1.2 \cos(124.86^\circ)} \begin{bmatrix} \cos(124.86^\circ) \\ \sin(124.86^\circ) \\ 0 \end{bmatrix} = \begin{bmatrix} -26336 \\ 37806 \\ 0 \end{bmatrix} \text{ (km)}$$

$$\underline{\mathbf{r} = -26336\hat{\mathbf{p}} + 37806\hat{\mathbf{q}} \text{ (km)}}$$

$$(2) \quad \{\mathbf{v}\}_{\bar{x}} = \frac{\mu}{h} \begin{bmatrix} -\sin \theta \\ e + \cos \theta \\ 0 \end{bmatrix} = \frac{398600}{81576} \begin{bmatrix} -\sin(124.86^\circ) \\ 1.5 + \cos(124.86^\circ) \\ 0 \end{bmatrix} = \begin{bmatrix} -4.3064 \\ 3.298 \\ 0 \end{bmatrix} \text{ (km/s)}$$

$$\underline{\mathbf{v} = -4.3064\hat{\mathbf{p}} + 3.298\hat{\mathbf{q}} \text{ (km/s)}}$$

$$(3) \quad [\mathbf{Q}]_{\bar{x}X} = \begin{bmatrix} -0.56561 & -0.3627 & 0.73994 \\ 0.33157 & -0.92236 & -0.19827 \\ 0.75441 & 0.13302 & 0.64279 \end{bmatrix} \quad \text{(Problem 4.13)}$$

$$(4) \quad \{\mathbf{r}\}_X = [\mathbf{Q}]_{\bar{x}X} \{\mathbf{r}\}_{\bar{x}} = \begin{bmatrix} 1207.2 \\ -43603 \\ -14839 \end{bmatrix} \text{ (km)} \quad \text{or} \quad \underline{\mathbf{r} = 1207.2\hat{\mathbf{I}} - 43603\hat{\mathbf{J}} - 14839\hat{\mathbf{K}} \text{ (km)}}$$

$$\{\mathbf{v}\}_X = [\mathbf{Q}]_{\bar{x}X} \{\mathbf{v}\}_{\bar{x}} = \begin{bmatrix} 1.2434 \\ -4.4698 \\ -2.8100 \end{bmatrix} \text{ (km/s)} \quad \text{or} \quad \underline{\mathbf{v} = 1.2434\hat{\mathbf{I}} - 4.4698\hat{\mathbf{J}} - 2.8100\hat{\mathbf{K}} \text{ (km/s)}}$$

**Problem 4.15**  $h = 75000 \text{ km}^2/\text{s}$   $e = 0.7$   $\theta = 25^\circ$

$$\{\mathbf{v}\}_{\bar{x}} = \frac{\mu}{h} \begin{Bmatrix} -\sin \theta \\ e + \cos \theta \\ 0 \end{Bmatrix} = \frac{398600}{75000} \begin{Bmatrix} -\sin(25^\circ) \\ 0.7 + \cos(25^\circ) \\ 0 \end{Bmatrix} = \begin{Bmatrix} -2.2461 \\ 8.537 \\ 0 \end{Bmatrix} \text{ (km/s)}$$

$$\{\mathbf{v}\}_X = [\mathbf{Q}]_{\bar{x}X} \{\mathbf{v}\}_{\bar{x}} = \begin{bmatrix} -0.83204 & 0.02741 & 0.55403 \\ -0.13114 & -0.98019 & -0.14845 \\ 0.53899 & -0.19617 & 0.81915 \end{bmatrix} \begin{Bmatrix} -2.2461 \\ 8.537 \\ 0 \end{Bmatrix} = \begin{Bmatrix} 2.1028 \\ -8.0733 \\ -2.8853 \end{Bmatrix} \text{ (km/s)}$$

or

$$\mathbf{v} = 2.1028\hat{\mathbf{I}} - 8.0733\hat{\mathbf{J}} - 2.8853\hat{\mathbf{K}} \text{ (km/s)}$$

**Problem 4.16**

$$\Omega = 60^\circ \quad \omega = 0 \quad i = 90^\circ$$

$$\{\mathbf{v}\}_{\bar{x}} = \begin{Bmatrix} -3.208 \\ -0.8288 \\ 0 \end{Bmatrix} \text{ (km/s)}$$

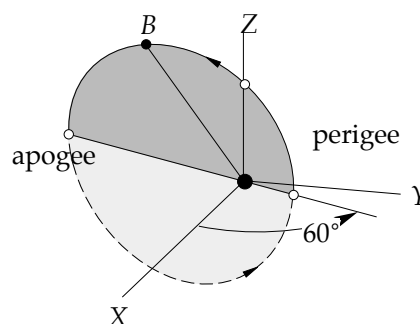

$$[\mathbf{Q}]_{\bar{x}X} = \begin{bmatrix} \cos \Omega \cos \omega - \sin \Omega \sin \omega \cos i & -\cos \Omega \sin \omega - \sin \Omega \cos i \cos \omega & \sin \Omega \sin i \\ \sin \Omega \cos \omega + \cos \Omega \cos i \sin \omega & -\sin \Omega \sin \omega + \cos \Omega \cos i \cos \omega & -\cos \Omega \sin i \\ \sin i \sin \omega & \sin i \cos \omega & \cos i \end{bmatrix}$$

$$= \begin{bmatrix} 0.5 & 0 & 0.86603 \\ 0.86603 & 0 & -0.5 \\ 0 & 1 & 0 \end{bmatrix}$$

$$\{\mathbf{v}\}_X = [\mathbf{Q}]_{\bar{x}X} \{\mathbf{v}\}_{\bar{x}} = \begin{Bmatrix} -1.604 \\ -2.7782 \\ -0.8288 \end{Bmatrix} \text{ (km/s)}$$

or

$$\mathbf{v} = -1.604\hat{\mathbf{I}} - 2.7782\hat{\mathbf{J}} - 0.8288\hat{\mathbf{K}} \text{ (km/s)}$$

**Problem 4.17**  $a = 7016 \text{ km}$   $e = 0.05$   $i = 45^\circ$   $\Omega = 0$   $\omega = 20^\circ$   $\theta = 10^\circ$

$$\{\mathbf{r}\}_{\bar{x}} = \frac{a(1-e^2)}{1+e\cos\theta} \begin{Bmatrix} \cos\theta \\ \sin\theta \\ 0 \end{Bmatrix} = \frac{7016(1-0.05^2)}{1+0.05\cos 10^\circ} \begin{Bmatrix} \cos 10^\circ \\ \sin 10^\circ \\ 0 \end{Bmatrix} = \begin{Bmatrix} 6568.7 \\ 1158.2 \\ 0 \end{Bmatrix} \text{ (km)}$$

$$\begin{aligned}
 [\mathbf{Q}]_{\bar{x}X} &= \begin{bmatrix} \cos \Omega \cos \omega - \sin \Omega \sin \omega \cos i & -\cos \Omega \sin \omega - \sin \Omega \cos i \cos \omega & \sin \Omega \sin i \\ \sin \Omega \cos \omega + \cos \Omega \cos i \sin \omega & -\sin \Omega \sin \omega + \cos \Omega \cos i \cos \omega & -\cos \Omega \sin i \\ \sin i \sin \omega & \sin i \cos \omega & \cos i \end{bmatrix} \\
 &= \begin{bmatrix} 0.93969 & -0.34202 & 0 \\ 0.24184 & 0.66446 & -0.70711 \\ 0.24184 & 0.66446 & 0.70711 \end{bmatrix} \\
 \{\mathbf{r}\}_X &= [\mathbf{Q}]_{\bar{x}X} \{\mathbf{r}\}_{\bar{x}} = \begin{bmatrix} 5776.4 \\ 2358.2 \\ 2358.2 \end{bmatrix} \text{ (km)} \\
 &\text{or} \\
 \mathbf{r} &= 5776.4\hat{\mathbf{i}} + 2358.2\hat{\mathbf{j}} + 2358.2\hat{\mathbf{k}} \text{ (km)}
 \end{aligned}$$

---

**Problem 4.18**

$$\begin{aligned}
 \dot{\Omega} &= -\frac{3}{2} \frac{\sqrt{\mu} J_2 R_{\text{earth}}^2}{(1-e^2)^2 a^{7/2}} \cos i \\
 a &= \frac{1}{2} (r_{\text{perigee}} + r_{\text{apogee}}) = \frac{1}{2} (6878 + 7378) = 7128 \text{ km} \\
 e &= \frac{r_{\text{apogee}} - r_{\text{perigee}}}{r_{\text{apogee}} + r_{\text{perigee}}} = \frac{7378 - 6878}{7378 + 6878} = 0.035073 \\
 \dot{\Omega} &= \frac{2\pi}{365.26 \cdot 24 \cdot 3600} = 1.991 \times 10^{-7} \text{ rad/s} \\
 1.991 \times 10^{-7} &= -\frac{3}{2} \frac{\sqrt{398600} \cdot 0.0010826 \cdot 6378^2}{(1-0.035073^2)^2 7128^{7/2}} \cos i \\
 1.991 \times 10^{-7} &= -1.367 \times 10^{-6} \cos i \Rightarrow i = 98.372^\circ
 \end{aligned}$$

---

**Problem 4.19**

$$\begin{aligned}
 T &= \frac{2\pi}{\sqrt{\mu}} r^{3/2} = \frac{2\pi}{\sqrt{398600}} (6378 + 180)^{3/2} = 5285.3 \text{ s} \\
 \dot{\Omega} &= -\frac{3}{2} \frac{\sqrt{\mu} J_2 R_{\text{earth}}^2}{r^{7/2}} \cos i = -\frac{3}{2} \frac{\sqrt{398600} \cdot 0.0010826 \cdot 6378^2}{(6378 + 180)^{7/2}} \cos 30^\circ = -1.5814 \times 10^{-6} \text{ rad/s} \\
 \omega_{\text{earth}} &= \frac{2\pi}{24 \cdot 3600} = 7.2921 \times 10^{-5} \text{ rad/s}
 \end{aligned}$$

Change in east longitude of the ascending node after 1 orbit of the satellite:

$$\Delta\lambda = (\omega_{\text{earth}} - \dot{\Omega})T = [7.2921 \times 10^{-5} - (-1.5814 \times 10^{-6})] \cdot 5285.3 = 0.39377 \text{ rad}$$

Spacing  $s$ ,

$$s = R_{\text{earth}} \Delta\lambda = 6378 \cdot 0.39377 = \underline{2511.4 \text{ km}}$$

---

**Problem 4.20**

The change in east longitude  $\lambda$  of the ascending node of a satellite after  $n_s$  orbits is



$$\Delta\lambda = (\omega_{\text{earth}} - \dot{\Omega})n_s T$$

If  $\Delta\lambda$  is an integral multiple  $n_e$  of earth rotations ( $2\pi$ ) then the ground track will close on itself,

$$2\pi n_e = (\omega_{\text{earth}} - \dot{\Omega})n_s T$$

Let  $v = n_s/n_e$ . Then  $2\pi = (\omega_{\text{earth}} - \dot{\Omega})vT$ , or

$$T = \frac{1}{v} \frac{2\pi}{\omega_{\text{earth}} - \dot{\Omega}} \quad (1)$$

But  $T = 2\pi r^{3/2}/\sqrt{\mu}$ , where  $r$  is the radius of the orbit. Thus

$$\frac{2\pi}{\sqrt{\mu}} r^{3/2} = \frac{1}{v} \frac{2\pi}{\omega_{\text{earth}} - \dot{\Omega}}$$

or

$$r = \left[ \frac{\sqrt{\mu}}{v(\omega_{\text{earth}} - \dot{\Omega})} \right]^{2/3} \quad (2)$$

For a circular orbit

$$\dot{\Omega} = -\frac{3}{2} \frac{\sqrt{\mu} J_2 R_{\text{earth}}^2}{r^{7/2}} \cos i$$

or

$$\cos i = -\frac{2}{3} \frac{r^{7/2}}{\sqrt{\mu} J_2 R_{\text{earth}}^2} \dot{\Omega}$$

Substituting (2) we get

$$\cos i = -\frac{2}{3} \frac{\left[ \frac{\sqrt{\mu}}{v(\omega_{\text{earth}} - \dot{\Omega})} \right]^{7/3}}{\sqrt{\mu} J_2 R_{\text{earth}}^2} \dot{\Omega} \quad (3)$$

Substituting

$$\begin{aligned} \omega_{\text{earth}} &= 7.2921 \times 10^{-5} \text{ rad} & \dot{\Omega} &= 1.997 \times 10^{-7} \text{ rad/s} \\ J_2 &= 0.0010826 & R_{\text{earth}} &= 6378 \text{ km} & \mu &= 398\,600 \text{ km}^3/\text{s}^2 \end{aligned}$$

into (1), (2) and (3) we get

$$i = \cos^{-1} \left( -\frac{73.948}{v^{7/3}} \right) \quad T = \frac{86\,400}{v} \quad z = \frac{42\,241}{v^{2/3}} - 6378$$

From these we obtain the following table of scenarios:

$v$	$z$ (km)	$i$ (deg)	$T$ (h)
17	11.042	95.711	1.4118
16	274.55	96.583	1.5000
15	567.03	97.658	1.6000
14	893.93	99.006	1.7143
13	1262.2	100.72	2.000
12	1681.0	102.96	2.1818
11	2162.6	105.95	2.4000
10	2722.6	110.07	2.6667
9	3384.8	116.03	3.0000
8	4182.3	125.29	3.4286

**Problem 4.21**

$$\dot{\omega} = -f \left( \frac{5}{2} \sin^2 i - 2 \right)$$

$$f = -\frac{\dot{\omega}}{\frac{5}{2} \sin^2 i - 2} = -\frac{7}{\frac{5}{2} \sin^2 40^\circ - 2} = 7.2384 \text{ deg/day}$$

$$\dot{\Omega} = -f \cos i = -7.2384 \cdot \cos 40^\circ = -5.545 \text{ deg/day}$$

**Problem 4.22** From

$$\mathbf{r}_o = -2429.1\hat{\mathbf{i}} + 4555.1\hat{\mathbf{j}} + 4577.0\hat{\mathbf{k}} \text{ (km)} \quad \mathbf{v}_o = -4.7689\hat{\mathbf{i}} - 5.6113\hat{\mathbf{j}} + 3.0535\hat{\mathbf{k}} \text{ (km/s)}$$

we obtain the orbital elements by means of *Algorithm 4.1*:

$$h = 55000 \text{ (km}^2/\text{s)} \quad e = 0.1 \quad \Omega_o = 70^\circ \quad i = 50^\circ \quad \omega_o = 60^\circ \quad \theta_o = 0$$

$$a = \frac{h^2}{\mu} \frac{1}{1-e^2} = \frac{55000^2}{398600} \frac{1}{1-0.1^2} = 7665.8 \text{ km}$$

$$T = \frac{2\pi}{\sqrt{\mu}} a^{3/2} = \frac{2\pi}{\sqrt{398600}} 7665.8^{3/2} = 6679.5 \text{ s}$$

The satellite is at perigee ( $\theta_o = 0$ ) so  $t_o = 0$ . After 72 hours,  $t_f = t_o + 72 \cdot 3600 = 259000 \text{ s}$ .

$t_f/T = 38.805$ , so  $t_f$  is in orbit 39. The time since perigee in orbit 39 is

$$t_{39} = (38.805 - 38)T = 5378.3 \text{ s}$$

$$\therefore M_{39} = \frac{2\pi}{T} t_{39} = \frac{2\pi}{6679.5} 5378.3 = 5.0952 \text{ rad}$$

$$E_{39} - e \sin E_{39} = M_{39}$$

$$E_{39} - 0.1 \sin E_{39} = 5.0952 \Rightarrow E_{39} = 4.9623 \text{ rad (Algorithm 3.1)}$$

$$\tan \frac{\theta_{39}}{2} = \sqrt{\frac{1+e}{1-e}} \tan \frac{E_{39}}{2} = \sqrt{\frac{1+0.1}{1-0.1}} \tan \frac{4.9623}{2} \Rightarrow \theta_{39} = 278.68^\circ$$

The perifocal state vector is

$$\{\mathbf{r}\}_{\bar{x}} = \frac{h^2}{\mu} \frac{1}{1 + e \cos \theta} \begin{Bmatrix} \cos \theta \\ \sin \theta \\ 0 \end{Bmatrix} = \frac{55000^2}{398600} \frac{1}{1 + 0.1 \cos(278.68^\circ)} \begin{Bmatrix} \cos(278.68^\circ) \\ \sin(278.68^\circ) \\ 0 \end{Bmatrix} = \begin{Bmatrix} 1128.9 \\ -7390.5 \\ 0 \end{Bmatrix} \text{ (km)}$$

$$\{\mathbf{v}\}_{\bar{x}} = \frac{\mu}{h} \begin{Bmatrix} -\sin \theta \\ e + \cos \theta \\ 0 \end{Bmatrix} = \frac{398600}{55000} \begin{Bmatrix} -\sin(278.68^\circ) \\ 0.1 + \cos(278.68^\circ) \\ 0 \end{Bmatrix} = \begin{Bmatrix} 7.1642 \\ 1.8191 \\ 0 \end{Bmatrix} \text{ (km/s)}$$

Update  $\Omega$  and  $\omega$ :

$$\begin{aligned} \dot{\Omega} &= -\frac{3}{2} \frac{\sqrt{\mu} J_2 R_{\text{earth}}^2}{(1-e^2)^2 a^{7/2}} \cos i = -\frac{3}{2} \frac{\sqrt{3998600} \cdot 0.0010826 \cdot 6378^2}{(1-0.1^2)^2 7665.8^{7/2}} \cos 50^\circ = -1.0789 \times 10^{-6} \cos 50^\circ \\ &= -6.9352 \times 10^{-7} \text{ rad/s} = -3.9736 \times 10^{-5} \text{ deg/s} \\ \therefore \Omega_{39} &= \Omega_1 + \dot{\Omega} \Delta t = 70^\circ - 3.9736 \times 10^{-5} \cdot 259200 = 59.701^\circ \end{aligned}$$

$$\begin{aligned} \dot{\omega} &= -\frac{3}{2} \frac{\sqrt{\mu} J_2 R_{\text{earth}}^2}{(1-e^2)^2 a^{7/2}} \left( \frac{5}{2} \sin^2 i - 2 \right) = -1.0789 \times 10^{-6} \left( \frac{5}{2} \sin^2 50^\circ - 2 \right) \\ &= 5.7599 \times 10^{-7} \text{ rad/s} = 3.2945 \times 10^{-5} \text{ deg/s} \\ \therefore \omega_{39} &= \omega_1 + \dot{\omega} \Delta t = 60^\circ + 3.2945 \times 10^{-5} \cdot 259200 = 68.539^\circ \end{aligned}$$

Update the transformation matrix between perifocal and geocentric equatorial coordinates:

$$\begin{aligned} [\mathbf{Q}]_{\bar{x}X} &= \begin{bmatrix} \cos \Omega_{39} \cos \omega_{39} - \sin \Omega_{39} \sin \omega_{39} \cos i & -\cos \Omega_{39} \sin \omega_{39} - \sin \Omega_{39} \cos i \cos \omega_{39} & \sin \Omega_{39} \sin i \\ \sin \Omega_{39} \cos \omega_{39} + \cos \Omega_{39} \cos i \sin \omega_{39} & -\sin \Omega_{39} \sin \omega_{39} + \cos \Omega_{39} \cos i \cos \omega_{39} & -\cos \Omega_{39} \sin i \\ \sin i \sin \omega & \sin i \cos \omega_{39} & \cos i \end{bmatrix} \\ &= \begin{bmatrix} -0.33192 & -0.67258 & 0.66141 \\ 0.6177 & -0.68489 & -0.38648 \\ 0.71294 & 0.28027 & 0.64278 \end{bmatrix} \end{aligned}$$

Compute the geocentric equatorial state vector at  $t_f$ :

$$\{\mathbf{r}\}_X = [\mathbf{Q}]_{\bar{x}X} \{\mathbf{r}\}_{\bar{x}} = \begin{Bmatrix} 4596 \\ 5759 \\ -1266.5 \end{Bmatrix} \text{ (km)} \quad \text{or} \quad \underline{\mathbf{r} = 4596\hat{\mathbf{i}} + 5759\hat{\mathbf{j}} - 1266.5\hat{\mathbf{k}} \text{ (km)}}$$

$$\{\mathbf{v}\}_X = [\mathbf{Q}]_{\bar{x}X} \{\mathbf{v}\}_{\bar{x}} = \begin{Bmatrix} -3.6014 \\ 3.1794 \\ 5.6174 \end{Bmatrix} \text{ (km/s)} \quad \text{or} \quad \underline{\mathbf{v} = -3.6014\hat{\mathbf{i}} + 3.1794\hat{\mathbf{j}} + 5.6174\hat{\mathbf{k}} \text{ (km/s)}}$$

**Problem 5.1**

The following MATLAB script uses the given data to compute  $\mathbf{v}_2$  by means of *Algorithm 5.1*, which is implemented as the M-function `gibbs` in Appendix D.10. The output to the MATLAB Command Window is listed afterwards.

```
% ~~~~~
% Problem_5_01
% ~~~~~
%
% This program uses Algorithm 5.1 (Gibbs method) to obtain the state
% vector from the three coplanar position vectors provided in
% Problem 5.1.
%
% mu          - gravitational parameter (km^3/s^2)
% r1, r2, r3  - three coplanar geocentric position vectors (km)
% ierr        - 0 if r1, r2, r3 are found to be coplanar
%              1 otherwise
% v2          - the velocity corresponding to r2 (km/s)
%
% User M-function required: gibbs
% -----
clear
global mu
mu = 398600;

r1 = [5887 -3520 -1204];
r2 = [5572 -3457 -2376];
r3 = [5088 -3289 -3480];

%...Echo the input data to the command window:
fprintf('-----\n')
fprintf('\n Problem 5.1: Gibbs Method\n')
fprintf('\n Input data:\n')
fprintf('\n  Gravitational parameter (km^3/s^2) = %g\n', mu)
fprintf('\n  r1 (km) = [%g %g %g]', r1(1), r1(2), r1(3))
fprintf('\n  r2 (km) = [%g %g %g]', r2(1), r2(2), r2(3))
fprintf('\n  r3 (km) = [%g %g %g]', r3(1), r3(2), r3(3))
fprintf('\n\n');

%...Algorithm 5.1:
[v2, ierr] = gibbs(r1, r2, r3);

%...If the vectors r1, r2, r3, are not coplanar, abort:
if ierr == 1
    fprintf('\n  These vectors are not coplanar.\n\n')
    return
end

%...Output the results to the command window:
fprintf(' Solution:')
fprintf('\n');
fprintf('\n  v2 (km/s) = [%g %g %g]', v2(1), v2(2), v2(3))
fprintf('\n-----\n')

-----
Problem 5.1: Gibbs Method

Input data:

  Gravitational parameter (km^3/s^2) = 398600
```

```

r1 (km) = [5887  -3520  -1204]
r2 (km) = [5572  -3457  -2376]
r3 (km) = [5088  -3289  -3480]

```

Solution:

```

v2 (km/s) = [-2.50254  0.723248  -7.13125]
-----

```

$$\mathbf{v}_2 = -2.5025\hat{\mathbf{i}} + 0.72325\hat{\mathbf{j}} - 7.1312\hat{\mathbf{k}} \quad (\text{km/s})$$

---

### Problem 5.2

The following MATLAB script uses  $\mathbf{r}_2$  and  $\mathbf{v}_2$  from Problem 5.1 to compute the orbital elements by means of *Algorithm 4.1*, which is implemented as the M-function `coe_from_sv` in Appendix D.8. The output to the MATLAB Command Window is listed afterwards.

```

% ~~~~~
% Problem_5_02
% ~~~~~
%
% This program uses Algorithm 4.1 to obtain the orbital
% elements from the state vector obtained in Problem 5.1.
%
% pi    - 3.1415926...
% deg   - factor for converting between degrees and radians
% mu    - gravitational parameter (km^3/s^2)
% r     - position vector (km) in the geocentric equatorial frame
% v     - velocity vector (km/s) in the geocentric equatorial frame
% coe   - orbital elements [h e RA incl w TA a]
%       where h    = angular momentum (km^2/s)
%               e    = eccentricity
%               RA   = right ascension of the ascending node (rad)
%               incl = orbit inclination (rad)
%               w    = argument of perigee (rad)
%               TA   = true anomaly (rad)
%               a    = semimajor axis (km)
% T     - Period of an elliptic orbit (s)
%
% User M-function required: coe_from_sv
% -----

clear
global mu
deg = pi/180;
mu = 398600;

%...Data declaration for Problem 5.2:
r = [ 5572  -3457  -2376];
v = [-2.50254  0.723248  -7.13125];
%...

%...Algorithm 4.1:
coe = coe_from_sv(r,v);

%...Echo the input data and output results to the command window:
fprintf('-----\n')
fprintf('\n Problem 5.2: Orbital elements from state vector\n')
fprintf('\n Gravitational parameter (km^3/s^2) = %g\n', mu)
fprintf('\n State vector:\n')
fprintf('\n r (km)                = [%g  %g  %g]', ...

```

```

                                r(1), r(2), r(3))
fprintf('\n v (km/s)           = [%g %g %g]', ...
                                v(1), v(2), v(3))

disp(' ')
fprintf('\n Angular momentum (km^2/s) = %g', coe(1))
fprintf('\n Eccentricity              = %g', coe(2))
fprintf('\n Right ascension (deg)     = %g', coe(3)/deg)
fprintf('\n Inclination (deg)          = %g', coe(4)/deg)
fprintf('\n Argument of perigee (deg)    = %g', coe(5)/deg)
fprintf('\n True anomaly (deg)          = %g', coe(6)/deg)
fprintf('\n Semimajor axis (km):        = %g', coe(7))

%...if the orbit is an ellipse, output its period (Equation 2.73):
if coe(2)<1
    T = 2*pi/sqrt(mu)*coe(7)^1.5;
    fprintf('\n Period:')
    fprintf('\n   Seconds                = %g', T)
    fprintf('\n   Minutes                  = %g', T/60)
    fprintf('\n   Hours                    = %g', T/3600)
    fprintf('\n   Days                     = %g', T/24/3600)
end
fprintf('\n-----\n')

```

-----  
 Problem 5.2: Orbital elements from state vector

Gravitational parameter (km<sup>3</sup>/s<sup>2</sup>) = 398600

State vector:

```

r (km)           = [5572  -3457  -2376]
v (km/s)         = [-2.50254  0.723248  -7.13125]

```

```

Angular momentum (km^2/s) = 52948.9
Eccentricity              = 0.0127382
Right ascension (deg)     = 150.003
Inclination (deg)         = 95.0071
Argument of perigee (deg) = 151.688
True anomaly (deg)        = 48.3093
Semimajor axis (km):      = 7034.71
Period:
  Seconds                = 5871.93
  Minutes                = 97.8655
  Hours                  = 1.63109
  Days                   = 0.0679622

```

$$r_{\text{perigee}} = \frac{h^2}{\mu} \frac{1}{1+e} = \frac{52949^2}{398600} \frac{1}{1+0.012738} = 6945.1 \text{ km}$$

$$z_{\text{perigee}} = 6945.1 - 6378 = \underline{567.11 \text{ km}}$$

---

### Problem 5.3

As in Example 5.3, we set  $\mathbf{r}_1 = r_1 \hat{\mathbf{i}}$  and  $\mathbf{r}_2 = r_2 (\cos \Delta\theta \hat{\mathbf{i}} + \sin \Delta\theta \hat{\mathbf{j}})$ , where  $r_1 = 6978 \text{ km}$ ,  $r_2 = 6678 \text{ km}$  and  $\Delta\theta = 60^\circ$ . The following MATLAB script uses this data to compute  $\mathbf{v}_1$  and  $\mathbf{v}_2$  by means of *Algorithm 5.2*, which is implemented as the M-function `lambert` in Appendix D.11. The output to the MATLAB Command Window is listed afterwards.

```

% ~~~~~
% Problem 5_03a

```

```

% ~~~~~
%
% This program uses Algorithm 5.2 to solve Lambert's problem for the
% data provided in Problem 5.3.

% deg    - factor for converting between degrees and radians
% pi     - 3.1415926...
% mu     - gravitational parameter (km^3/s^2)
% r1, r2 - initial and final radii (km)
% dt     - time between r1 and r2 (s)
% dtheta - change in true anomaly during dt (degrees)
% R1, R2 - initial and final position vectors (km)
% string - = 'pro' if the orbit is prograde
%         = 'retro' if the orbit is retrograde
% V1, V2 - initial and final velocity vectors (km/s)

% User M-function required: lambert
% -----
clear
global mu
mu      = 398600;          %km^3/s^2
deg     = pi/180;

r1      = 6378 + 600;     %km
r2      = 6378 + 300;     %km
dt      = 15*60;         %sec
dtheta  = 60;            %degrees

R1 = [r1 0 0];
R2 = [r2*cos(dtheta*deg) r2*sin(dtheta*deg) 0];

%...Algorithm 5.2:
string = 'pro';
[V1 V2] = lambert(R1, R2, dt, string);

%...Echo the input data and output results to the command window:
fprintf('\n-----\n')
fprintf('\n Problem 5.3: Lambert''s Problem\n')

fprintf('\n Input data:\n');
fprintf('\n   Gravitational parameter (km^3/s^2) = %g\n', mu)
fprintf('\n   Radius 1 (km) = %g', r1)
fprintf('\n   Position vector R1 (km) = [%g %g %g]\n',...
        R1(1), R1(2), R1(3))
fprintf('\n   Radius 2 (km) = %g', r2)
fprintf('\n   Position vector R2 (km) = [%g %g %g]\n',...
        R2(1), R2(2), R2(3))
fprintf('\n   Elapsed time (s) = %g', dt)
fprintf('\n   Change in true anomaly (deg) = %g', dtheta)

fprintf('\n\n Solution:\n')
fprintf('\n   Velocity vector V1 (km/s) = [%g %g %g]',...
        V1(1), V1(2), V1(3))
fprintf('\n   Velocity vector V2 (km/s) = [%g %g %g]',...
        V2(1), V2(2), V2(3))
fprintf('\n-----\n')

-----
Problem 5.3: Lambert's Problem

Input data:

```

```

Gravitational parameter (km^3/s^2) = 398600

Radius 1 (km)           = 6978
Position vector R1 (km) = [6978  0  0]

Radius 2 (km)           = 6678
Position vector R2 (km) = [3339  5783.32  0]

Elapsed time (s)        = 900
Change in true anomaly (deg) = 60

```

Solution:

```

Velocity vector V1 (km/s) = [-0.544135  7.68498  0]
Velocity vector V2 (km/s) = [-6.98129  3.96849  0]
-----

```

To find the perigee altitude, we need the orbital elements. The following MATLAB script uses  $\mathbf{r}_1 = 6978\hat{\mathbf{i}}$  (km) and  $\mathbf{v}_1 = -0.544135\hat{\mathbf{i}} + 7.68498\hat{\mathbf{j}}$  (km/s) from above to compute the orbital elements by means of *Algorithm 4.1*, which is implemented as the M-function `coe_from_sv` in Appendix D.8. The output to the MATLAB Command Window is listed afterwards.

```

% ~~~~~
% Problem_5_03b
% ~~~~~
%
% This program employs Algorithm 4.1 to obtain the orbital
% elements from the state vector found from the solution
% of Lambert's problem using the data given in Problem 5.3.
%
% pi - 3.1415926...
% deg - factor for converting between degrees and radians
% mu - gravitational parameter (km^3/s^2)
% r - position vector (km) in the geocentric equatorial frame
% v - velocity vector (km/s) in the geocentric equatorial frame
% coe - orbital elements [h e RA incl w TA a]
%       where h = angular momentum (km^2/s)
%              e = eccentricity
%              RA = right ascension of the ascending node (rad)
%              incl = orbit inclination (rad)
%              w = argument of perigee (rad)
%              TA = true anomaly (rad)
%              a = semimajor axis (km)
% T - Period of an elliptic orbit (s)
%
% User M-function required: coe_from_sv
% -----

clear
global mu
deg = pi/180;
mu = 398600;

%...Data declaration for Problem 5.3:
r = [6978  0  0];
v = [-0.544135  7.68498  0];
%...

%...Algorithm 4.1:
coe = coe_from_sv(r,v);

%...Echo the input data and output results to the command window:

```



```

fprintf('-----\n')
fprintf('\n Problem 5.3: Orbital elements from state vector\n')
fprintf('\n Gravitational parameter (km^3/s^2) = %g\n', mu)
fprintf('\n State vector:\n')
fprintf('\n r (km)                = [%g %g %g]', ...
        r(1), r(2), r(3))
fprintf('\n v (km/s)              = [%g %g %g]', ...
        v(1), v(2), v(3))

disp(' ')
fprintf('\n Angular momentum (km^2/s) = %g', coe(1))
fprintf('\n Eccentricity                = %g', coe(2))
fprintf('\n Right ascension (deg)         = %g', coe(3)/deg)
fprintf('\n Inclination (deg)             = %g', coe(4)/deg)
fprintf('\n Argument of perigee (deg)     = %g', coe(5)/deg)
fprintf('\n True anomaly (deg)           = %g', coe(6)/deg)
fprintf('\n Semimajor axis (km):         = %g', coe(7))

%...if the orbit is an ellipse, output its period (Equation 2.73):
if coe(2)<1
    T = 2*pi/sqrt(mu)*coe(7)^1.5;
    fprintf('\n Period:')
    fprintf('\n   Seconds                = %g', T)
    fprintf('\n   Minutes                 = %g', T/60)
    fprintf('\n   Hours                   = %g', T/3600)
    fprintf('\n   Days                    = %g', T/24/3600)
end
fprintf('\n-----\n')

```

-----

Problem 5.3: Orbital elements from state vector

Gravitational parameter (km<sup>3</sup>/s<sup>2</sup>) = 398600

State vector:

r (km) = [6978 0 0]  
v (km/s) = [-0.544135 7.68498 0]

Angular momentum (km<sup>2</sup>/s) = 53625.8  
Eccentricity = 0.0806743  
Right ascension (deg) = 0  
Inclination (deg) = 0  
Argument of perigee (deg) = 0  
True anomaly (deg) = 294.849  
Semimajor axis (km): = 7261.83  
Period:  
 Seconds = 6158.57  
 Minutes = 102.643  
 Hours = 1.71071  
 Days = 0.0712798

-----

$$r_{\text{perigee}} = \frac{h^2}{\mu} \frac{1}{1+e} = \frac{53626^2}{398600} \frac{1}{1+0.0806743} = 6676 \text{ km}$$

$$z_{\text{perigee}} = 6676 - 6378 = \underline{298 \text{ km}}$$

---

**Problem 5.4** The following MATLAB script uses  $\mathbf{r}_1$ ,  $\mathbf{r}_2$  and  $\Delta t$  to compute  $\mathbf{v}_1$  and  $\mathbf{v}_2$  by means of *Algorithm 5.2*, which is implemented as the M-function `lambert` in Appendix D.11. The output to the MATLAB Command Window is listed afterwards.

```

% ~~~~~
% Problem_5_04
% ~~~~~
%
% This program uses Algorithm 5.2 to solve Lambert's problem for the
% data provided in Problem 5.4.
%
% mu      - gravitational parameter (km^3/s^2)
% r1, r2  - initial and final position vectors (km)
% dt      - time between r1 and r2 (s)
% string  - = 'pro' if the orbit is prograde
%          = 'retro' if the orbit is retrograde
% v1, v2  - initial and final velocity vectors (km/s)
% coe     - orbital elements [h e RA incl w TA a]
%
% User M-function required: lambert
% -----

clear
global mu
deg = pi/180;

%...Data declaration for Problem 5.4:
mu      = 398600;
r1      = [-3600  3600  5100];
r2      = [-5500  -6240  -520];
dt      = 30*60;
string  = 'pro';
%...

%...Algorithm 5.2:
[v1, v2] = lambert(r1, r2, dt, string);

%...Echo the input data and output the results to the command window:
fprintf('-----\n')
fprintf('\n Problem 5.4: Lambert's Problem\n')
fprintf('\n Input data:\n');
fprintf('\n   Gravitational parameter (km^3/s^2) = %g\n', mu);
fprintf('\n   r1 (km)                = [%g %g %g]', ...
        r1(1), r1(2), r1(3))
fprintf('\n   r2 (km)                = [%g %g %g]', ...
        r2(1), r2(2), r2(3))
fprintf('\n   Elapsed time (s) = %g', dt);
fprintf('\n\n Solution:\n')

fprintf('\n   v1 (km/s)             = [%g %g %g]', ...
        v1(1), v1(2), v1(3))
fprintf('\n   v2 (km/s)             = [%g %g %g]', ...
        v2(1), v2(2), v2(3))
fprintf('\n-----\n')

-----
Problem 5.4: Lambert's Problem

Input data:

Gravitational parameter (km^3/s^2) = 398600

r1 (km)          = [-3600  3600  5100]
r2 (km)          = [-5500  -6240  -520]
Elapsed time (s) = 1800

```

Solution:

$$\begin{aligned} \mathbf{v}_1 \text{ (km/s)} &= [-5.68521 \quad -5.19833 \quad 0.348733] \\ \mathbf{v}_2 \text{ (km/s)} &= [3.42204 \quad -3.24131 \quad -4.71994] \end{aligned}$$

---

$$\mathbf{v}_1 = -5.6852\hat{\mathbf{i}} - 5.1983\hat{\mathbf{j}} + 0.34873\hat{\mathbf{k}} \text{ (km/s)} \quad \mathbf{v}_2 = 3.4220\hat{\mathbf{i}} - 3.2413\hat{\mathbf{j}} - 4.7199\hat{\mathbf{k}} \text{ (km/s)}$$

---

**Problem 5.5** The following MATLAB script uses  $\mathbf{r}_1 = -3600\hat{\mathbf{i}} + 3600\hat{\mathbf{j}} + 5100\hat{\mathbf{k}}$  (km) and  $\mathbf{v}_1 = -5.6852\hat{\mathbf{i}} - 5.1983\hat{\mathbf{j}} + 0.34873\hat{\mathbf{k}}$  (km/s) from Problem 5.4 to compute the orbital elements by means of *Algorithm 4.1*, which is implemented as the M-function `coe_from_sv` in Appendix D.8. The output to the MATLAB Command Window is listed afterwards.

```
% ~~~~~
% Problem_5_05
% ~~~~~
%
% This program employs Algorithm 4.1 to obtain the orbital
% elements from the state vector found in Problem 5.4.
%
% pi    - 3.1415926...
% deg   - factor for converting between degrees and radians
% mu    - gravitational parameter (km^3/s^2)
% r     - position vector (km) in the geocentric equatorial frame
% v     - velocity vector (km/s) in the geocentric equatorial frame
% coe   - orbital elements [h e RA incl w TA a]
%       where h    = angular momentum (km^2/s)
%               e    = eccentricity
%               RA  = right ascension of the ascending node (rad)
%               incl = orbit inclination (rad)
%               w   = argument of perigee (rad)
%               TA  = true anomaly (rad)
%               a   = semimajor axis (km)
% T     - Period of an elliptic orbit (s)
%
% User M-function required: coe_from_sv
% ~~~~~

clear
global mu
deg = pi/180;
mu = 398600;

%...Data declaration for Problem 5.5:
r = [ -3600    3600    5100];
v = [-5.68521 -5.19833  0.348733];
%...

%...Algorithm 4.1:
coe = coe_from_sv(r,v);

%...Echo the input data and output results to the command window:
fprintf('-----')
fprintf('\n Problem 5.5: Orbital elements from state vector\n')
fprintf('\n Gravitational parameter (km^3/s^2) = %g\n', mu)
fprintf('\n State vector:\n')
fprintf('\n r (km)                = [%g %g %g]', ...
        r(1), r(2), r(3))
fprintf('\n v (km/s)             = [%g %g %g]', ...
```

```

                                v(1), v(2), v(3))
disp(' ')
fprintf('\n Angular momentum (km^2/s) = %g', coe(1))
fprintf('\n Eccentricity                = %g', coe(2))
fprintf('\n Right ascension (deg)        = %g', coe(3)/deg)
fprintf('\n Inclination (deg)             = %g', coe(4)/deg)
fprintf('\n Argument of perigee (deg)      = %g', coe(5)/deg)
fprintf('\n True anomaly (deg)              = %g', coe(6)/deg)
fprintf('\n Semimajor axis (km):              = %g', coe(7))

%...if the orbit is an ellipse, output its period (Equation 2.73):
if coe(2)<1
    T = 2*pi/sqrt(mu)*coe(7)^1.5;
    fprintf('\n Period:')
    fprintf('\n   Seconds                = %g', T)
    fprintf('\n   Minutes                  = %g', T/60)
    fprintf('\n   Hours                    = %g', T/3600)
    fprintf('\n   Days                     = %g', T/24/3600)
end
fprintf('\n-----\n')

```

-----

Problem 5.5: Orbital elements from state vector

Gravitational parameter (km<sup>3</sup>/s<sup>2</sup>) = 398600

State vector:

```

r (km)                = [-3600  3600  5100]
v (km/s)              = [-5.68521  -5.19833  0.348733]

```

```

Angular momentum (km^2/s) = 55458
Eccentricity                = 0.0982445
Right ascension (deg)       = 45.0287
Inclination (deg)           = 45.0497
Argument of perigee (deg)   = 46.034
True anomaly (deg)         = 43.9458
Semimajor axis (km):        = 7791.19
Period:
  Seconds                   = 6844.1
  Minutes                   = 114.068
  Hours                     = 1.90114
  Days                      = 0.0792142

```

-----

$$r_{\text{perigee}} = \frac{h^2}{\mu} \frac{1}{1+e} = \frac{55458^2}{398600} \frac{1}{1+0.098244} = 7025.7 \text{ km}$$

$$z_{\text{perigee}} = 7025.7 - 6378 = \underline{647.74 \text{ km}}$$

---

**Problem 5.6** The following MATLAB script uses  $\mathbf{r}_1$ ,  $\mathbf{r}_2$  and  $\Delta t$  to compute  $\mathbf{v}_1$  and  $\mathbf{v}_2$  by means of *Algorithm 5.2*, which is implemented as the M-function `lambert` in Appendix D.11. The output to the MATLAB Command Window is listed afterwards.

(a)

```

% ~~~~~
% Problem_5_06
% ~~~~~
%
% This program uses Algorithm 5.2 to solve Lambert's problem for the
% data provided in Problem 5.6.
%

```

```

% mu      - gravitational parameter (km^3/s^2)
% r1, r2  - initial and final position vectors (km)
% dt      - time between r1 and r2 (s)
% string  - = 'pro' if the orbit is prograde
%          = 'retro' if the orbit is retrograde
% v1, v2  - initial and final velocity vectors (km/s)
% coe     - orbital elements [h e RA incl w TA a]
%
% User M-function required: lambert
% -----

clear
global mu
deg = pi/180;

%...Data declaration for Problem 5.6:
mu      = 398600;
r1      = [ 5644  -2830  -4170];
r2      = [-2240   7320  -4980];
dt      = 20*60;
string  = 'pro';
%...

%...Algorithm 5.2:
[v1, v2] = lambert(r1, r2, dt, string);

%...Echo the input data and output the results to the command window:
fprintf('-----\n')
fprintf('\n Problem 5.6: Lambert's Problem\n')
fprintf('\n Input data:\n');
fprintf('\n   Gravitational parameter (km^3/s^2) = %g\n', mu);
fprintf('\n   r1 (km)                = [%g %g %g]', ...
        r1(1), r1(2), r1(3))
fprintf('\n   r2 (km)                = [%g %g %g]', ...
        r2(1), r2(2), r2(3))
fprintf('\n   Elapsed time (s) = %g', dt);
fprintf('\n\n Solution:\n')

fprintf('\n   v1 (km/s)              = [%g %g %g]', ...
        v1(1), v1(2), v1(3))
fprintf('\n   v2 (km/s)              = [%g %g %g]', ...
        v2(1), v2(2), v2(3))
fprintf('\n-----\n')

-----
Problem 5.6: Lambert's Problem

Input data:

   Gravitational parameter (km^3/s^2) = 398600

   r1 (km)                = [5644  -2830  -4170]
   r2 (km)                = [-2240   7320  -4980]
   Elapsed time (s) = 1200

Solution:

   v1 (km/s)              = [-4.13223   9.01237  -4.3781]
   v2 (km/s)              = [-7.28524   6.31978   2.5272]
-----

```

$$\underline{v_1 = -4.1322\hat{I} + 9.0124\hat{J} - 4.3781\hat{K} \text{ (km/s)}} \quad \underline{v_2 = -7.2852\hat{I} + 6.3198\hat{J} + 2.5272\hat{K} \text{ (km/s)}}$$

**Problem 5.7** The following MATLAB script uses  $\mathbf{r}_1 = 5644\hat{I} - 2830\hat{J} - 4170\hat{K}$  (km) and  $\mathbf{v}_1 = -4.1322\hat{I} + 9.0124\hat{J} - 4.3781\hat{K}$  (km/s) from Problem 5.4 to compute the orbital elements by means of *Algorithm 4.1*, which is implemented as the M-function `coe_from_sv` in Appendix D.8. The output to the MATLAB Command Window is listed afterwards.

```

% ~~~~~
% Problem_5_07
% ~~~~~
%
% This program employs Algorithm 4.1 to obtain the orbital
% elements from the state vector found in Problem 5.6.
%
% pi    - 3.1415926...
% deg   - factor for converting between degrees and radians
% mu    - gravitational parameter (km^3/s^2)
% r     - position vector (km) in the geocentric equatorial frame
% v     - velocity vector (km/s) in the geocentric equatorial frame
% coe   - orbital elements [h e RA incl w TA a]
%       where h    = angular momentum (km^2/s)
%               e    = eccentricity
%               RA   = right ascension of the ascending node (rad)
%               incl = orbit inclination (rad)
%               w    = argument of perigee (rad)
%               TA   = true anomaly (rad)
%               a    = semimajor axis (km)
% T     - Period of an elliptic orbit (s)
%
% User M-function required: coe_from_sv
% -----

clear
global mu
deg = pi/180;
mu  = 398600;

%...Data declaration for Problem 5.7:
r = [ 5644   -2830   -4170];
v = [-4.13223  9.01237  -4.3781];
%...

%...Algorithm 4.1:
coe = coe_from_sv(r,v);

%...Echo the input data and output results to the command window:
fprintf('-----\n')
fprintf('\n Problem 5.7: Orbital elements from state vector\n')
fprintf('\n Gravitational parameter (km^3/s^2) = %g\n', mu)
fprintf('\n State vector:\n')
fprintf('\n r (km)                                = [%g %g %g]', ...
        r(1), r(2), r(3))
fprintf('\n v (km/s)                               = [%g %g %g]', ...
        v(1), v(2), v(3))

disp(' ')
fprintf('\n Angular momentum (km^2/s) = %g', coe(1))
fprintf('\n Eccentricity                 = %g', coe(2))
fprintf('\n Right ascension (deg)        = %g', coe(3)/deg)
fprintf('\n Inclination (deg)           = %g', coe(4)/deg)
fprintf('\n Argument of perigee (deg)    = %g', coe(5)/deg)
fprintf('\n True anomaly (deg)          = %g', coe(6)/deg)

```

```

fprintf('\n Semimajor axis (km):          = %g', coe(7))

%...if the orbit is an ellipse, output its period (Equation 2.73):
if coe(2)<1
    T = 2*pi/sqrt(mu)*coe(7)^1.5;
    fprintf('\n Period:')
    fprintf('\n      Seconds          = %g', T)
    fprintf('\n      Minutes            = %g', T/60)
    fprintf('\n      Hours              = %g', T/3600)
    fprintf('\n      Days                = %g', T/24/3600)
end
fprintf('\n-----\n')

```

-----

Problem 5.7: Orbital elements from state vector

Gravitational parameter (km<sup>3</sup>/s<sup>2</sup>) = 398600

State vector:

r (km) = [5644 -2830 -4170]  
v (km/s) = [-4.13223 9.01237 -4.3781]

Angular momentum (km<sup>2</sup>/s) = 76096.4  
Eccentricity = 1.20053  
Right ascension (deg) = 130.007  
Inclination (deg) = 59.0184  
Argument of perigee (deg) = 259.98  
True anomaly (deg) = 320.023  
Semimajor axis (km): = -32922.3

-----

$$r_{\text{perigee}} = \frac{h^2}{\mu} \frac{1}{1+e} = \frac{76096^2}{398600} \frac{1}{1+1.2005} = 6601.8 \text{ km}$$

$$z_{\text{perigee}} = 6601.8 - 6378 = \underline{223.82 \text{ km}}$$

---

**Problem 5.8** The following MATLAB script uses the M-function J0 in Appendix D.12 to compute the Julian day for the date given in part (a) of Problem 5.8. The output to the MATLAB Command Window is listed afterwards, as are the results for the dates (b) through (c).

```

% ~~~~~
% Problem_5_08a
% ~~~~~
%
% This program computes J0 and the Julian day number using the data
% in Problem 5.8.
%
% year   - range: 1901 - 2099
% month  - range: 1 - 12
% day    - range: 1 - 31
% hour   - range: 0 - 23 (Universal Time)
% minute - range: 0 - 60
% second - range: 0 - 60
% ut     - universal time (hr)
% j0     - Julian day number at 0 hr UT
% jd     - Julian day number at specified UT
%
% User M-function required: J0
% -----

```

```

clear

%...Data declaration for Problem 5.8a:
year   = 1914;
month  = 8;
day    = 14;

hour   = 5;
minute = 30;
second = 00;
%...

ut = hour + minute/60 + second/3600;

%...Equation 5.46:
j0 = J0(year, month, day);

%...Equation 5.47:
jd = j0 + ut/24;

%...Echo the input data and output the results to the command window:
fprintf('-----\n')
fprintf('\n Example 5.8a: Julian day calculation\n')
fprintf('\n Input data:\n');
fprintf('\n   Year           = %g',   year)
fprintf('\n   Month          = %g',   month)
fprintf('\n   Day            = %g',   day)
fprintf('\n   Hour           = %g',   hour)
fprintf('\n   Minute         = %g',   minute)
fprintf('\n   Second        = %g\n',  second)

fprintf('\n Julian day number = %11.3f', jd);
fprintf('\n-----\n')

-----
Example 5.8a: Julian day calculation

Input data:

   Year           = 1914
   Month          = 8
   Day            = 14
   Hour           = 5
   Minute         = 30
   Second        = 0

Julian day number = 2420358.729
-----
Example 5.8b: Julian day calculation

Input data:

   Year           = 1946
   Month          = 4
   Day            = 18
   Hour           = 14
   Minute         = 0
   Second        = 0

Julian day number = 2431929.083
-----
Example 5.8c: Julian day calculation

```



Input data:

```

Year           = 2010
Month          = 9
Day            = 1
Hour           = 0
Minute         = 0
Second         = 0

```

Julian day number = 2455440.500

---

Example 5.8d: Julian day calculation

Input data:

```

Year           = 2007
Month          = 10
Day            = 16
Hour           = 12
Minute         = 0
Second         = 0

```

Julian day number = 2454390.000

---

**Problem 5.9** This is similar to Example 5.5. The MATLAB script listed in the solution to Problem 5.8 can be used to obtain the Julian day numbers.

---

**Problem 5.10** The following MATLAB script uses *Algorithm 5.3*, which is implemented in MATLAB by the M-function `LST` in Appendix D.13, to compute the local sidereal time for the data given in part (a) of Problem 5.10. The output to the MATLAB Command Window is listed afterwards, as are the results for the data in (b) through (e).

```

% ~~~~~
% Problem_5_10a
% ~~~~~
%
% This program uses Algorithm 5.3 to obtain the local sidereal
% time from the data provided in Problem 5.10.
%
% lst    - local sidereal time (degrees)
% EL     - east longitude of the site (west longitude is negative):
%          degrees (0 - 360)
%          minutes (0 - 60)
%          seconds (0 - 60)
% WL     - west longitude
% year   - range: 1901 - 2099
% month  - range: 1 - 12
% day    - range: 1 - 31
% ut     - universal time
%          hour (0 - 23)
%          minute (0 - 60)
%          second (0 - 60)
%
% User M-function required: LST
% -----
clear

%...Data declaration for Problem 5.10a:

```

```

% East longitude:
degrees = 18;
minutes = 3;
seconds = 0;

% Date:
year = 2008;
month = 1;
day = 1;

% Universal time:
hour = 12;
minute = 0;
second = 0;

%...

%...Convert negative (west) longitude to east longitude:
if degrees < 0
    degrees = degrees + 360;
end

%...Express the longitudes as decimal numbers:
EL = degrees + minutes/60 + seconds/3600;
WL = 360 - EL;

%...Express universal time as a decimal number:
ut = hour + minute/60 + second/3600;

%...Algorithm 5.3:
lst = LST(year, month, day, ut, EL);

%...Echo the input data and output the results to the command window:
fprintf('-----\n')
fprintf('\n Problem 5.10a: Local sidereal time calculation\n')
fprintf('\n Input data:\n');
fprintf('\n   Year                = %g', year)
fprintf('\n   Month               = %g', month)
fprintf('\n   Day                 = %g', day)
fprintf('\n   UT (hr)             = %g', ut)
fprintf('\n   West Longitude (deg) = %g', WL)
fprintf('\n   East Longitude (deg) = %g', EL)
fprintf('\n\n');

fprintf(' Solution:')
fprintf('\n');
fprintf('\n Local Sidereal Time (deg) = %g', lst)
fprintf('\n Local Sidereal Time (hr) = %g', lst/15)
fprintf('\n-----\n')

-----
Problem 5.10a: Local sidereal time calculation

Input data:

Year                = 2008
Month               = 1
Day                 = 1
UT (hr)             = 12
West Longitude (deg) = 341.95
East Longitude (deg) = 18.05

```

Solution:

Local Sidereal Time (deg) = 298.572  
 Local Sidereal Time (hr) = 19.9048

---

Problem 5.10b: Local sidereal time calculation

Input data:

Year = 2007  
 Month = 12  
 Day = 21  
 UT (hr) = 10  
 West Longitude (deg) = 215.033  
 East Longitude (deg) = 144.967

Solution:

Local Sidereal Time (deg) = 24.5646  
 Local Sidereal Time (hr) = 1.63764

---

Problem 5.10c: Local sidereal time calculation

Input data:

Year = 2005  
 Month = 7  
 Day = 4  
 UT (hr) = 20  
 West Longitude (deg) = 118.25  
 East Longitude (deg) = 241.75

Solution:

Local Sidereal Time (deg) = 104.676  
 Local Sidereal Time (hr) = 6.9784

---

Problem 5.10d: Local sidereal time calculation

Input data:

Year = 2006  
 Month = 2  
 Day = 15  
 UT (hr) = 3  
 West Longitude (deg) = 43.1  
 East Longitude (deg) = 316.9

Solution:

Local Sidereal Time (deg) = 146.884  
 Local Sidereal Time (hr) = 9.79228

---

Problem 5.10e: Local sidereal time calculation

Input data:

Year = 2006  
 Month = 3  
 Day = 21  
 UT (hr) = 8  
 West Longitude (deg) = 228.067  
 East Longitude (deg) = 131.933

Solution:

$$\begin{aligned}\text{Local Sidereal Time (deg)} &= 70.6348 \\ \text{Local Sidereal Time (hr)} &= 4.70899\end{aligned}$$

-----

**Problem 5.11.**  $\theta = 117^\circ$   $\phi = 51^\circ$   $A = 28^\circ$   $a = 68^\circ$ .

From Equation 5.83a,

$$\begin{aligned}\delta &= \sin^{-1}(\cos \phi \cos A \cos a + \sin \phi \sin a) = \sin^{-1}(\cos 51^\circ \cos 28^\circ \cos 68^\circ + \sin 51^\circ \sin 68^\circ) \\ \delta &= 68.235^\circ\end{aligned}$$

From Equation 5.83b, since  $A < 180^\circ$ ,

$$\begin{aligned}h &= 360^\circ - \cos^{-1}\left(\frac{\cos \phi \sin a - \sin \phi \cos A \cos a}{\cos \delta}\right) \\ &= 360^\circ - \cos^{-1}\left(\frac{\cos 51^\circ \sin 68^\circ - \sin 51^\circ \cos 28^\circ \cos 68^\circ}{\cos 68.235^\circ}\right) \\ &= 331.69^\circ\end{aligned}$$

From Equation 5.83c

$$\alpha = \theta - h = 117^\circ - 331.69^\circ = -214.69$$

Placing this within the range  $0 \leq \theta \leq 360^\circ$ ,

$$\alpha = 145.31^\circ$$

**Problem 5.12** The following MATLAB script uses *Algorithm 5.4*, which is implemented in MATLAB by the M-function `rv_from_observe` in Appendix D.14, to compute the state vector of a space object from the data given in Problem 5.12. The output to the MATLAB Command Window is listed afterwards.

```
% ~~~~~
% Problem_5_12
% ~~~~~
%
% This program uses Algorithm 5.4 to obtain the state
% vector from the observational data provided in Problem 5.12.
%
% deg      - conversion factor between degrees and radians
% pi       - 3.1415926...
% mu       - gravitational parameter (km^3/s^2)
%
% Re       - equatorial radius of the earth (km)
% f        - earth's flattening factor
% wE       - angular velocity of the earth (rad/s)
% omega    - earth's angular velocity vector (rad/s) in the
%           geocentric equatorial frame
%
% rho      - slant range of object (km)
% rhodot   - range rate (km/s)
% A        - azimuth (deg) of object relative to observation site
% Adot     - time rate of change of azimuth (deg/s)
% a        - elevation angle (deg) of object relative to observation
% site
```

```

% adot    - time rate of change of elevation angle (degrees/s)

% theta   - local sidereal time (deg) of tracking site
% phi     - geodetic latitude (deg) of site
% H       - elevation of site (km)

% r       - geocentric equatorial position vector of object (km)
% v       - geocentric equatorial velocity vector of object (km)

% coe     - orbital elements [h e RA incl w TA a]
%         where
%         h     = angular momentum (km^2/s)
%         e     = eccentricity
%         RA    = right ascension of the ascending node (rad)
%         incl  = inclination of the orbit (rad)
%         w     = argument of perigee (rad)
%         TA    = true anomaly (rad)
%         a     = semimajor axis (km)
% rp      - perigee radius (km)
% T       - period of elliptical orbit (s)
%
% User M-function required: rv_from_observe
% -----

clear
global f Re wE mu

deg      = pi/180;
f        = 0.0033528;
Re       = 6378;
wE       = 7.2921e-5;
mu       = 398600;

%...Data declaration for Problem 5.12:
rho      = 988;
rhodot  = 4.86;
A        = 36;
Adot    = 0.59;
a        = 36.6;
adot    = -0.263;
theta    = 40;
phi      = 35;
H        = 0;
%...

%...Algorithm 5.4:
[r,v] = rv_from_observe(rho, rhodot, A, Adot, a, adot, theta, phi, H);

%...Echo the input data and output the solution to
% the command window:
fprintf('-----')
fprintf('\n Problem 5.12')
fprintf('\n\n Input data:\n');
fprintf('\n Slant range (km)                = %g', rho);
fprintf('\n Slant range rate (km/s)           = %g', rhodot);
fprintf('\n Azimuth (deg)                     = %g', A);
fprintf('\n Azimuth rate (deg/s)              = %g', Adot);
fprintf('\n Elevation (deg)                   = %g', a);
fprintf('\n Elevation rate (deg/s)            = %g', adot);
fprintf('\n Local sidereal time (deg)         = %g', theta);
fprintf('\n Latitude (deg)                    = %g', phi);
fprintf('\n Altitude above sea level (km)     = %g', H);
fprintf('\n\n');

```

```

fprintf(' Solution:')

fprintf('\n\n State vector:\n');
fprintf('\n r (km)                = [%g, %g, %g]', ...
        r(1), r(2), r(3));
fprintf('\n v (km/s)              = [%g, %g, %g]', ...
        v(1), v(2), v(3));
fprintf('\n-----\n')

```

-----  
 Problem 5.12

Input data:

```

Slant range (km)                = 988
Slant range rate (km/s)         = 4.86
Azimuth (deg)                   = 36
Azimuth rate (deg/s)            = 0.59
Elevation (deg)                 = 36.6
Elevation rate (deg/s)          = -0.263
Local sidereal time (deg)       = 40
Latitude (deg)                  = 35
Altitude above sea level (km)   = 0

```

Solution:

State vector:

```

r (km)                = [3794.66, 3792.71, 4501.31]
v (km/s)              = [-7.72483, 7.72134, 0.0186586]

```

---

$$\mathbf{r} = 3794.7\hat{\mathbf{i}} + 3792.7\hat{\mathbf{j}} + 4501.3\hat{\mathbf{k}} \text{ (km)} \quad \mathbf{v} = -7.7248\hat{\mathbf{i}} + 7.72134\hat{\mathbf{j}} + 0.018659\hat{\mathbf{k}} \text{ (km/s)}$$

**Problem 5.13** The following MATLAB script uses the state vector found in Problem 5.12 to compute the orbital elements by means of *Algorithm 4.1*, which is implemented as the M-function `coe_from_sv` in Appendix D.8. The output to the MATLAB Command Window is listed afterwards.

```

% ~~~~~
% Problem_5_13
% ~~~~~
%
% This program employs Algorithm 4.1 to obtain the orbital
% elements from the state vector found in Problem 5.12.
%
% pi    - 3.1415926...
% deg   - factor for converting between degrees and radians
% mu    - gravitational parameter (km^3/s^2)
% r     - position vector (km) in the geocentric equatorial frame
% v     - velocity vector (km/s) in the geocentric equatorial frame
% coe   - orbital elements [h e RA incl w TA a]
%       where h    = angular momentum (km^2/s)
%               e    = eccentricity
%               RA  = right ascension of the ascending node (rad)
%               incl = orbit inclination (rad)
%               w   = argument of perigee (rad)
%               TA  = true anomaly (rad)
%               a   = semimajor axis (km)
% T     - Period of an elliptic orbit (s)
%

```

```

% User M-function required: coe_from_sv
% -----

clear
global mu
deg = pi/180;
mu = 398600;

%...Data declaration for Problem 5.13:
r = [ 3794.66, 3792.71, 4501.31];
v = [-7.72483, 7.72134, 0.0186586];
%...

%...Algorithm 4.1:
coe = coe_from_sv(r,v);

%...Echo the input data and output results to the command window:
fprintf('-----\n')
fprintf('\n Problem 5.13: Orbital elements from state vector\n')
fprintf('\n Gravitational parameter (km^3/s^2) = %g\n', mu)
fprintf('\n State vector:\n')
fprintf('\n r (km)                = [%g %g %g]', ...
        r(1), r(2), r(3))
fprintf('\n v (km/s)              = [%g %g %g]', ...
        v(1), v(2), v(3))

disp(' ')
fprintf('\n Angular momentum (km^2/s) = %g', coe(1))
fprintf('\n Eccentricity                = %g', coe(2))
fprintf('\n Right ascension (deg)         = %g', coe(3)/deg)
fprintf('\n Inclination (deg)             = %g', coe(4)/deg)
fprintf('\n Argument of perigee (deg)     = %g', coe(5)/deg)
fprintf('\n True anomaly (deg)           = %g', coe(6)/deg)
fprintf('\n Semimajor axis (km):         = %g', coe(7))

%...if the orbit is an ellipse, output its period (Equation 2.73):
if coe(2)<1
    T = 2*pi/sqrt(mu)*coe(7)^1.5;
    fprintf('\n Period:')
    fprintf('\n   Seconds                = %g', T)
    fprintf('\n   Minutes                 = %g', T/60)
    fprintf('\n   Hours                   = %g', T/3600)
    fprintf('\n   Days                    = %g', T/24/3600)
end
fprintf('\n-----\n')

-----
Problem 5.13: Orbital elements from state vector

Gravitational parameter (km^3/s^2) = 398600

State vector:

r (km)                = [3794.66 3792.71 4501.31]
v (km/s)              = [-7.72483 7.72134 0.0186586]

Angular momentum (km^2/s) = 76490.5
Eccentricity                = 1.09593
Right ascension (deg)         = 315.13
Inclination (deg)             = 39.9968
Argument of perigee (deg)     = 89.8097
True anomaly (deg)           = 0.0797759
Semimajor axis (km):         = -73003.5
-----

```

**Problem 5.14** The local sidereal time  $\theta$ , azimuth  $A$ , angular elevation  $a$  and slant range  $\rho$  are provided at three observation times. The rates are not provided, but we can still use *Algorithm 5.4*, implemented in MATLAB as `rv_from_observe` in Appendix D.14, to find just the position vectors at each of the times. The following MATLAB script carries out this procedure, passing zeros to `rv_from_observe` as values for the rates. The output to the MATLAB Command Window follows.

```
% ~~~~~
% Problem_5_10a
% ~~~~~
%
% This program uses Algorithm 5.4 to find the geocentric position
% vectors corresponding to the three sets of azimuth, elevation
% and slant range data given in Problem 5.14

% deg    - conversion factor between degrees and radians
% pi     - 3.1415926...

% Re     - equatorial radius of the earth (km)
% f      - earth's flattening factor
% wE     - angular velocity of the earth (rad/s) (not required in
%         this problem)

% t      - vector of three observation times (min)
% rho    - vector of slant ranges (km) of the object at the three
%         observation times
% az     - vector of azimuths (deg) of the object relative to the
%         observation site at the three observation times
% el     - vector of elevation angles (deg) of the object relative to
%         the observation site at the three observation times

% theta  - vector of local sidereal times (deg) of the tracking site
at
%         the three observation times
% phi    - geodetic latitude (deg) of site
% H      - elevation of site (km)

% r      - geocentric equatorial position vector of object (km)
% v      - geocentric equatorial velocity vector of object (km)
%         (not computed since the rates of rho, az and el are not
given)

% User M-function required: rv_from_observe
% -----
clear

global f Re wE

deg    = pi/180;
Re     = 6378;
f      = 0.0033528;
wE     = 7.292115e-5;

%...Data declaration for Problem 5.14:
phi    = -20;
H      = 0.5;
t      = [0 2 4];
theta  = [60.0    60.5014  61.0027];
az     = [165.931  145.967  2.40962];
el     = [9.53549  45.7711  21.8825];
rho    = [1214.89  421.441  732.079];
%...
```



```

%...Echo the input data to the command window:
fprintf('-----\n')
fprintf('\n Problem 5.14')
fprintf('\n\n Input data (angles in degrees):\n');
fprintf('\n Time')
fprintf('\n (min)      Azimuth      Elevation      Slant range\n')

for i = 1:3
fprintf('\n %5.1f%15.5e%15.5e%15.5e',t(i), az(i), el(i), rho(i))
end

%...Output the solution to the command window:
fprintf('\n\n Solution:')
fprintf('\n\n Time')
fprintf('\n (min)      Geocentric position vector (km)\n')

for i = 1:3
%...Algorithm 5.4:
    [r,v] = rv_from_observe(rho(i), 0, az(i), 0, el(i), ...
                           0, theta(i), phi, H);
    fprintf('\n %5.1f      [%g %g %g]',t(i), r(1), r(2), r(3))
end
fprintf('\n-----\n')

```

-----  
Problem 5.14

Input data (angles in degrees):

Time (min)	Azimuth	Elevation	Slant range
0.0	1.65931e+02	9.53549e+00	1.21489e+03
2.0	1.45967e+02	4.57711e+01	4.21441e+02
4.0	2.40962e+00	2.18825e+01	7.32079e+02

Solution:

Time (min)	Geocentric position vector (km)
0.0	[2641.68 5158.02 -3328.73]
2.0	[2908.04 5474.36 -2500.03]
4.0	[3118.6 5685.65 -1623.34]

$$\mathbf{r}_1 = 2641.7\hat{\mathbf{I}} + 5158.0\hat{\mathbf{J}} - 3328.7\hat{\mathbf{K}} \text{ (km)}$$

$$\mathbf{r}_2 = 2908.0\hat{\mathbf{I}} + 5474.4\hat{\mathbf{J}} - 2500.0\hat{\mathbf{K}} \text{ (km)}$$

$$\mathbf{r}_3 = 3118.6\hat{\mathbf{I}} + 5685.6\hat{\mathbf{J}} - 1623.3\hat{\mathbf{K}} \text{ (km)}$$

Using these three position vectors we employ Gibbs' method, Algorithm 5.1, which is implemented in MATLAB as the M-function `gibbs` in Appendix D.10. The following MATLAB script calls upon `gibbs` to find the velocity vector  $\mathbf{v}_2$  corresponding to the position vector  $\mathbf{r}_2$ . The output is listed afterward.

```

% ~~~~~
% Problem_5_14b
% ~~~~~
%
% This program uses Algorithm 5.1 (Gibbs method) to obtain the state

```

```

% vector from the three coplanar position vectors found in the first
% part of Problem 5.14.
%
% mu      - gravitational parameter (km^3/s^2)
% r1, r2, r3 - three coplanar geocentric position vectors (km)
% ierr    - 0 if r1, r2, r3 are found to be coplanar
%         - 1 otherwise
% v2      - the velocity corresponding to r2 (km/s)
%
% User M-function required: gibbs
% -----
clear
global mu
mu = 398600;

r1 = [2641.68  5158.02  -3328.73];
r2 = [2908.04  5474.36  -2500.03];
r3 = [3118.6   5685.65  -1623.34];

%...Echo the input data to the command window:
fprintf('-----\n')
fprintf('\n Problem 5.14: Gibbs Method\n')
fprintf('\n Input data:\n')
fprintf('\n  Gravitational parameter (km^3/s^2) = %g\n', mu)
fprintf('\n  r1 (km) = [%g  %g  %g]', r1(1), r1(2), r1(3))
fprintf('\n  r2 (km) = [%g  %g  %g]', r2(1), r2(2), r2(3))
fprintf('\n  r3 (km) = [%g  %g  %g]', r3(1), r3(2), r3(3))
fprintf('\n\n');

%...Algorithm 5.1:
[v2, ierr] = gibbs(r1, r2, r3);

%...If the vectors r1, r2, r3, are not coplanar, abort:
if ierr == 1
    fprintf('\n  These vectors are not coplanar.\n\n')
    return
end

%...Output the results to the command window:
fprintf(' Solution:')
fprintf('\n');
fprintf('\n  v2 (km/s) = [%g  %g  %g]', v2(1), v2(2), v2(3))
fprintf('\n-----\n')

-----
Problem 5.14: Gibbs Method

Input data:

  Gravitational parameter (km^3/s^2) = 398600

  r1 (km) = [2641.68  5158.02  -3328.73]
  r2 (km) = [2908.04  5474.36  -2500.03]
  r3 (km) = [3118.6   5685.65  -1623.34]

Solution:

  v2 (km/s) = [1.99357  2.20552  7.12881]
-----

 $v_2 = 1.9936\hat{i} + 2.2055\hat{j} + 7.1288\hat{k}$  (km/s)

```

**Problem 5.15** The following MATLAB script uses  $\mathbf{r}_2$  and  $\mathbf{v}_2$  from Problem 5.14 to compute the orbital elements by means of *Algorithm 4.1*, which is implemented as the M-function `coe_from_sv` in Appendix D.8. The output to the MATLAB Command Window is listed afterwards.

```

% ~~~~~
% Problem_5_15
% ~~~~~
%
% This program uses Algorithm 4.1 to obtain the orbital
% elements from the state vector obtained in Problem 5.14.
%
% pi    - 3.1415926...
% deg   - factor for converting between degrees and radians
% mu    - gravitational parameter (km^3/s^2)
% r     - position vector (km) in the geocentric equatorial frame
% v     - velocity vector (km/s) in the geocentric equatorial frame
% coe   - orbital elements [h e RA incl w TA a]
%       where h    = angular momentum (km^2/s)
%               e    = eccentricity
%               RA   = right ascension of the ascending node (rad)
%               incl = orbit inclination (rad)
%               w    = argument of perigee (rad)
%               TA   = true anomaly (rad)
%               a    = semimajor axis (km)
% T     - Period of an elliptic orbit (s)
%
% User M-function required: coe_from_sv
% -----

clear
global mu
deg = pi/180;
mu  = 398600;

%...Data declaration for Problem 5.15:
r = [2908.04  5474.36  -2500.03];
v = [1.99357  2.20552   7.12881];
%...

%...Algorithm 4.1:
coe = coe_from_sv(r,v);

%...Echo the input data and output results to the command window:
fprintf('-----\n')
fprintf('\n Problem 5.15: Orbital elements from state vector\n')
fprintf('\n Gravitational parameter (km^3/s^2) = %g\n', mu)
fprintf('\n State vector:\n')
fprintf('\n r (km)                                = [%g %g %g]', ...
        r(1), r(2), r(3))
fprintf('\n v (km/s)                               = [%g %g %g]', ...
        v(1), v(2), v(3))

disp(' ')
fprintf('\n Angular momentum (km^2/s) = %g', coe(1))
fprintf('\n Eccentricity                 = %g', coe(2))
fprintf('\n Right ascension (deg)         = %g', coe(3)/deg)
fprintf('\n Inclination (deg)             = %g', coe(4)/deg)
fprintf('\n Argument of perigee (deg)     = %g', coe(5)/deg)
fprintf('\n True anomaly (deg)           = %g', coe(6)/deg)
fprintf('\n Semimajor axis (km):         = %g', coe(7))

%...if the orbit is an ellipse, output its period (Equation 2.73):
if coe(2)<1

```

```

T = 2*pi/sqrt(mu)*coe(7)^1.5;
fprintf('\n Period:')
fprintf('\n   Seconds           = %g', T)
fprintf('\n   Minutes            = %g', T/60)
fprintf('\n   Hours              = %g', T/3600)
fprintf('\n   Days                = %g', T/24/3600)
end
fprintf('\n-----\n')

```

-----

Problem 5.15: Orbital elements from state vector

Gravitational parameter (km<sup>3</sup>/s<sup>2</sup>) = 398600

State vector:

r (km) = [2908.04 5474.36 -2500.03]  
v (km/s) = [1.99357 2.20552 7.12881]

Angular momentum (km<sup>2</sup>/s) = 51626.3  
Eccentricity = 0.00102595  
Right ascension (deg) = 60.0001  
Inclination (deg) = 95.0003  
Argument of perigee (deg) = 270.34  
True anomaly (deg) = 67.6075  
Semimajor axis (km): = 6686.59  
Period:  
Seconds = 5441.5  
Minutes = 90.6916  
Hours = 1.51153  
Days = 0.0629803

-----

---

**Problems 5.16 and 5.17** The following MATLAB script uses Equations 5.55 and 5.56 to convert the data given in Problem 5.16 into three tracking site position vectors ( $\mathbf{R}_1, \mathbf{R}_2, \mathbf{R}_3$ ) and three space object direction cosine vectors ( $\hat{\rho}_1, \hat{\rho}_2, \hat{\rho}_3$ ). These vectors together with the three observation times are then handed off to the M-function `gauss` (Appendix D.15). `gauss` implements both the Gauss *Algorithm 5.5* to compute an approximation of the state vector ( $\mathbf{r}, \mathbf{v}$ ) and *Algorithm 5.6*, which iteratively improves it. The output to the MATLAB Command Window is listed afterwards.

```

% ~~~~~
% Problem_5_16
% ~~~~~
%
% This program uses Algorithms 5.5 and 5.6 (Gauss's method) to compute
% the state vector from the angles only data provided in Problem 5.16.
%
% deg          - factor for converting between degrees and radians
% pi           - 3.1415926...
% mu           - gravitational parameter (km^3/s^2)
% Re           - earth's equatorial radius (km)
% f            - earth's flattening factor
% H            - elevation of observation site (km)
% phi         - latitude of site (deg)
% t            - vector of observation times t1, t2, t3 (s)
% ra           - vector of topocentric equatorial right ascensions
%              at t1, t2, t3 (deg)
% dec         - vector of topocentric equatorial right declinations
%              at t1, t2, t3 (deg)
% theta       - vector of local sidereal times for t1, t2, t3 (deg)
% R            - matrix of site position vectors at t1, t2, t3 (km)

```

```

% rho          - matrix of direction cosine vectors at t1, t2, t3
% fac1, fac2   - common factors
% r_old, v_old - the state vector without iterative improvement (km,
km/s)
% r, v         - the state vector with iterative improvement (km,
km/s)
%
% User M-function required: gauss
% -----

clear

global mu

deg = pi/180;
mu  = 398600;
Re  = 6378;
f   = 1/298.26;

%...Data declaration for Problem 5.16:
H    = 0;
phi  = 29*deg;
t    = [ 0          60          120    ];
ra   = [ 0          6.59279e+01  7.98500e+01]*deg;
dec  = [ 5.15110e+01  2.79911e+01  1.46609e+01]*deg;
theta = [ 0          2.50684e-01  5.01369e-01]*deg;
%...

%...Equations 5.56, 5.57:
fac1 = Re/sqrt(1-(2*f - f*f)*sin(phi)^2);
fac2 = (Re*(1-f)^2/sqrt(1-(2*f - f*f)*sin(phi)^2) + H)*sin(phi);
for i = 1:3
    R(i,1) = (fac1 + H)*cos(phi)*cos(theta(i));
    R(i,2) = (fac1 + H)*cos(phi)*sin(theta(i));
    R(i,3) = fac2;
    rho(i,1) = cos(dec(i))*cos(ra(i));
    rho(i,2) = cos(dec(i))*sin(ra(i));
    rho(i,3) = sin(dec(i));
end

%...Algorithms 5.5 and 5.6:
[r, v, r_old, v_old] = gauss(rho(1,:), rho(2,:), rho(3,:), ...
                             R(1,:), R(2,:), R(3,:), ...
                             t(1), t(2), t(3));

%...Echo the input data and output the solution to
% the command window:
fprintf('-----')
fprintf('\n Problems 5.16 and 5.17: Orbit determination')
fprintf('\n          by the Gauss method\n')
fprintf('\n Radius of earth (km)          = %g', Re)
fprintf('\n Flattening factor              = %g', f)
fprintf('\n Gravitational parameter (km^3/s^2) = %g', mu)
fprintf('\n\n Input data:\n');
fprintf('\n Latitude (deg) of tracking site = %g', phi/deg);
fprintf('\n Altitude (km) above sea level   = %g', H);
fprintf('\n\n Observations:')
fprintf('\n          Right')
fprintf('          Local')
fprintf('\n Time (s) Ascension (deg) Declination (deg)')
fprintf(' Sidereal time (deg)')
for i = 1:3
    fprintf('\n %9.4g %11.4f %19.4f %20.4f', ...

```

```

        t(i), ra(i)/deg, dec(i)/deg, theta(i)/deg)
end

fprintf('\n\n Solution:\n')

fprintf('\n Without iterative improvement (Problem 5.16)...\n')
fprintf('\n  r (km)   = [%g, %g, %g]', r_old(1), r_old(2), r_old(3))
fprintf('\n  v (km/s) = [%g, %g, %g]', v_old(1), v_old(2), v_old(3))
fprintf('\n');
fprintf('\n With iterative improvement (Problem 5.17)...\n')
fprintf('\n  r (km)   = [%g, %g, %g]', r(1), r(2), r(3))
fprintf('\n  v (km/s) = [%g, %g, %g]', v(1), v(2), v(3))
fprintf('\n-----\n')

```

```

-----
Problems 5.16 and 5.17: Orbit determination
                        by the Gauss method

```

```

Radius of earth (km)           = 6378
Flattening factor              = 0.00335278
Gravitational parameter (km^3/s^2) = 398600

```

Input data:

```

Latitude (deg) of tracking site = 29
Altitude (km) above sea level  = 0

```

Observations:

Time (s) (deg)	Right Ascension (deg)	Declination (deg)	Local Sidereal time
0	0.0000	51.5110	0.0000
60	65.9279	27.9911	0.2507
120	79.8500	14.6609	0.5014

Solution:

Without iterative improvement (Problem 5.16)...

```

r (km)   = [5788.09, 484.257, 3341.52]
v (km/s) = [-0.460072, 8.05816, -0.265618]

```

With iterative improvement (Problem 5.17)...

```

r (km)   = [5788.42, 485.007, 3341.96]
v (km/s) = [-0.460926, 8.0706, -0.266112]

```

---

**Problem 5.18** The following MATLAB script uses  $\mathbf{r}_2$  and  $\mathbf{v}_2$  from Problem 5.17 to compute the orbital elements by means of *Algorithm 4.1*, which is implemented as the M-function `coe_from_sv` in Appendix D.8. The output to the MATLAB Command Window is listed afterwards.

```

% ~~~~~
% Problem_5_18
% ~~~~~
%
% This program uses Algorithm 4.1 to obtain the orbital
% elements from the state vector obtained in Problem 5.17.
%
% pi   - 3.1415926...

```

```

% deg - factor for converting between degrees and radians
% mu - gravitational parameter (km^3/s^2)
% r - position vector (km) in the geocentric equatorial frame
% v - velocity vector (km/s) in the geocentric equatorial frame
% coe - orbital elements [h e RA incl w TA a]
%       where h = angular momentum (km^2/s)
%              e = eccentricity
%              RA = right ascension of the ascending node (rad)
%              incl = orbit inclination (rad)
%              w = argument of perigee (rad)
%              TA = true anomaly (rad)
%              a = semimajor axis (km)
% T - Period of an elliptic orbit (s)
%
% User M-function required: coe_from_sv
% -----

clear
global mu
deg = pi/180;
mu = 398600;

%...Data declaration for Problem 5.18:
r = [ 5788.42, 485.007, 3341.96];
v = [-0.460926, 8.0706, -0.266112];
%...

%...Algorithm 4.1:
coe = coe_from_sv(r,v);

%...Echo the input data and output results to the command window:
fprintf('-----\n')
fprintf('\n Problem 5.18: Orbital elements from state vector\n')
fprintf('\n Gravitational parameter (km^3/s^2) = %g\n', mu)
fprintf('\n State vector:\n')
fprintf('\n r (km) = [%g %g %g]', ...
        r(1), r(2), r(3))
fprintf('\n v (km/s) = [%g %g %g]', ...
        v(1), v(2), v(3))

disp(' ')
fprintf('\n Angular momentum (km^2/s) = %g', coe(1))
fprintf('\n Eccentricity = %g', coe(2))
fprintf('\n Right ascension (deg) = %g', coe(3)/deg)
fprintf('\n Inclination (deg) = %g', coe(4)/deg)
fprintf('\n Argument of perigee (deg) = %g', coe(5)/deg)
fprintf('\n True anomaly (deg) = %g', coe(6)/deg)
fprintf('\n Semimajor axis (km): = %g', coe(7))

%...if the orbit is an ellipse, output its period (Equation 2.73):
if coe(2)<1
    T = 2*pi/sqrt(mu)*coe(7)^1.5;
    fprintf('\n Period:')
    fprintf('\n Seconds = %g', T)
    fprintf('\n Minutes = %g', T/60)
    fprintf('\n Hours = %g', T/3600)
    fprintf('\n Days = %g', T/24/3600)
end
fprintf('\n-----\n')

Problem 5.18: Orbital elements from state vector

Gravitational parameter (km^3/s^2) = 398600

```

State vector:

r (km) = [5788.42 485.007 3341.96]  
v (km/s) = [-0.460926 8.0706 -0.266112]

Angular momentum (km<sup>2</sup>/s) = 54201.2  
Eccentricity = 0.100054  
Right ascension (deg) = 270  
Inclination (deg) = 30.0001  
Argument of perigee (deg) = 89.9993  
True anomaly (deg) = 4.15098  
Semimajor axis (km): = 7444.75  
Period:  
    Seconds = 6392.73  
    Minutes = 106.546  
    Hours = 1.77576  
    Days = 0.07399

**Problems 5.19** The following MATLAB script uses Equations 5.55 and 5.56 to convert the data given in Problem 5.19 into three tracking site position vectors ( $\mathbf{R}_1, \mathbf{R}_2, \mathbf{R}_3$ ) and three space object direction cosine vectors ( $\hat{\rho}_1, \hat{\rho}_2, \hat{\rho}_3$ ). These vectors together with the three observation times are then handed off to the M-function `gauss` (Appendix D.15). `gauss` implements both the *Gauss Algorithm 5.5* to compute an approximation of the state vector ( $\mathbf{r}, \mathbf{v}$ ) and *Algorithm 5.6*, which iteratively improves it. The output to the MATLAB Command Window is listed afterwards.

```
%
%-----
% Problem_5_19
% ~~~~~
%
% This program uses Algorithms 5.5 and 5.6 (Gauss's method) to
compute
% the state vector from the angles only data provided in Problem
5.16.
%
% deg          - factor for converting between degrees and radians
% pi           - 3.1415926...
% mu           - gravitational parameter (km^3/s^2)
% Re           - earth's equatorial radius (km)
% f            - earth's flattening factor
% H            - elevation of observation site (km)
% phi          - latitude of site (deg)
% t            - vector of observation times t1, t2, t3 (s)
% ra           - vector of topocentric equatorial right ascensions
%              at t1, t2, t3 (deg)
% dec          - vector of topocentric equatorial right declinations
%              at t1, t2, t3 (deg)
% theta        - vector of local sidereal times for t1, t2, t3 (deg)
% R            - matrix of site position vectors at t1, t2, t3 (km)
% rho          - matrix of direction cosine vectors at t1, t2, t3
% fac1, fac2   - common factors
% r_old, v_old - the state vector without iterative improvement (km,
km/s)
% r, v         - the state vector with iterative improvement (km,
km/s)
%
% User M-function required: gauss
%-----
-
```



```

clear

global mu

deg = pi/180;
mu = 398600;
Re = 6378;
f = 1/298.26;

%...Data declaration for Problem 5.19:
H = 0;
phi = 29*deg;
t = [ 0 60 120];
ra = [15.0394 25.7539 48.6055]*deg;
dec = [20.7487 30.1410 43.8910]*deg;
theta = [ 90 90.2507 90.5014]*deg;
%...

%...Equations 5.56, 5.57:
fac1 = Re/sqrt(1-(2*f - f*f)*sin(phi)^2);
fac2 = (Re*(1-f)^2/sqrt(1-(2*f - f*f)*sin(phi)^2) + H)*sin(phi);
for i = 1:3
    R(i,1) = (fac1 + H)*cos(phi)*cos(theta(i));
    R(i,2) = (fac1 + H)*cos(phi)*sin(theta(i));
    R(i,3) = fac2;
    rho(i,1) = cos(dec(i))*cos(ra(i));
    rho(i,2) = cos(dec(i))*sin(ra(i));
    rho(i,3) = sin(dec(i));
end

%...Algorithms 5.5 and 5.6:
[r, v, r_old, v_old] = gauss(rho(1,:), rho(2,:), rho(3,:), ...
                             R(1,:), R(2,:), R(3,:), ...
                             t(1), t(2), t(3));

%...Echo the input data and output the solution to
% the command window:
fprintf('-----\n')
fprintf('\n Problems 5.19 and 5.20: Orbit determination')
fprintf('\n by the Gauss method\n')
fprintf('\n Radius of earth (km) = %g', Re)
fprintf('\n Flattening factor = %g', f)
fprintf('\n Gravitational parameter (km^3/s^2) = %g', mu)
fprintf('\n\n Input data:\n');
fprintf('\n Latitude (deg) of tracking site = %g', phi/deg);
fprintf('\n Altitude (km) above sea level = %g', H);
fprintf('\n\n Observations:')
fprintf('\n Right')
fprintf(' Local')
fprintf('\n Time (s) Ascension (deg) Declination (deg)')
fprintf(' Sidereal time (deg)')
for i = 1:3
    fprintf('\n %9.4g %11.4f %19.4f %20.4f', ...
            t(i), ra(i)/deg, dec(i)/deg, theta(i)/deg)
end

fprintf('\n\n Solution:\n')

fprintf('\n Without iterative improvement (Problem 5.19)... \n')
fprintf('\n r (km) = [%g, %g, %g]', r_old(1), r_old(2), r_old(3))
fprintf('\n v (km/s) = [%g, %g, %g]', v_old(1), v_old(2), v_old(3))
fprintf('\n');

```

```
fprintf('\n\n With iterative improvement (Problem 5.20)... \n')
fprintf('\n r (km) = [%g, %g, %g]', r(1), r(2), r(3))
fprintf('\n v (km/s) = [%g, %g, %g]', v(1), v(2), v(3))
fprintf('\n-----\n')
```

Problems 5.19 and 5.20: Orbit determination  
by the Gauss method

```
Radius of earth (km)           = 6378
Flattening factor              = 0.00335278
Gravitational parameter (km^3/s^2) = 398600
```

Input data:

```
Latitude (deg) of tracking site = 29
Altitude (km) above sea level   = 0
```

Observations:

Time (s) (deg)	Right		Local
	Ascension (deg)	Declination (deg)	Sidereal time
0	15.0394	20.7487	90.0000
60	25.7539	30.1410	90.2507
120	48.6055	43.8910	90.5014

Solution:

Without iterative improvement (Problem 5.19)...

```
r (km) = [765.19, 5963.6, 3582.88]
v (km/s) = [-7.50919, 0.705265, 0.423729]
```

With iterative improvement (Problem 5.20)...

```
r (km) = [766.265, 5964.12, 3583.57]
v (km/s) = [-7.51882, 0.706233, 0.42431]
```

Approximate state vector:

$$\mathbf{r} = 765.19\hat{\mathbf{I}} + 5963.60\hat{\mathbf{J}} + 3582.88\hat{\mathbf{K}} \text{ (km)} \quad \mathbf{v} = -7.50919\hat{\mathbf{I}} + 0.705265\hat{\mathbf{J}} + 0.423729\hat{\mathbf{K}} \text{ (km/s)}$$

---

**Problem 5.20** From the MATLAB output in the previous problem solution, the refined state vector is

$$\mathbf{r} = 766.265\hat{\mathbf{I}} + 5964.12\hat{\mathbf{J}} + 3583.57\hat{\mathbf{K}} \text{ (km)} \quad \mathbf{v} = -7.51882\hat{\mathbf{I}} + 0.706233\hat{\mathbf{J}} + 0.42431\hat{\mathbf{K}} \text{ (km/s)}$$

---

**Problem 5.21** The following MATLAB script uses  $\mathbf{r}$  and  $\mathbf{v}$  from Problem 5.20 to compute the orbital elements by means of *Algorithm 4.1*, which is implemented as the M-function `coe_from_sv` in Appendix D.8. The output to the MATLAB Command Window is listed afterwards.

```
% ~~~~~
% Problem_5_21
% ~~~~~
%
% This program uses Algorithm 4.1 to obtain the orbital
% elements from the state vector obtained in Problem 5.20.
%
% pi - 3.1415926...
% deg - factor for converting between degrees and radians
```

```

% mu - gravitational parameter (km^3/s^2)
% r - position vector (km) in the geocentric equatorial frame
% v - velocity vector (km/s) in the geocentric equatorial frame
% coe - orbital elements [h e RA incl w TA a]
%       where h = angular momentum (km^2/s)
%             e = eccentricity
%             RA = right ascension of the ascending node (rad)
%             incl = orbit inclination (rad)
%             w = argument of perigee (rad)
%             TA = true anomaly (rad)
%             a = semimajor axis (km)
% T - Period of an elliptic orbit (s)
%
% User M-function required: coe_from_sv
% -----

clear
global mu
deg = pi/180;
mu = 398600;

%...Data declaration for Problem 5.21:
r = [ 766.265, 5964.12, 3583.57];
v = [-7.51882, 0.706233, 0.42431];
%...

%...Algorithm 4.1:
coe = coe_from_sv(r,v);

%...Echo the input data and output results to the command window:
fprintf('-----\n')
fprintf('\n Problem 5.21: Orbital elements from state vector\n')
fprintf('\n Gravitational parameter (km^3/s^2) = %g\n', mu)
fprintf('\n State vector:\n')
fprintf('\n r (km) = [%g %g %g]', ...
        r(1), r(2), r(3))
fprintf('\n v (km/s) = [%g %g %g]', ...
        v(1), v(2), v(3))

disp(' ')
fprintf('\n Angular momentum (km^2/s) = %g', coe(1))
fprintf('\n Eccentricity = %g', coe(2))
fprintf('\n Right ascension (deg) = %g', coe(3)/deg)
fprintf('\n Inclination (deg) = %g', coe(4)/deg)
fprintf('\n Argument of perigee (deg) = %g', coe(5)/deg)
fprintf('\n True anomaly (deg) = %g', coe(6)/deg)
fprintf('\n Semimajor axis (km): = %g', coe(7))

%...if the orbit is an ellipse, output its period (Equation 2.73):
if coe(2)<1
    T = 2*pi/sqrt(mu)*coe(7)^1.5;
    fprintf('\n Period:')
    fprintf('\n Seconds = %g', T)
    fprintf('\n Minutes = %g', T/60)
    fprintf('\n Hours = %g', T/3600)
    fprintf('\n Days = %g', T/24/3600)
end
fprintf('\n-----\n')

-----

Problem 5.21: Orbital elements from state vector

Gravitational parameter (km^3/s^2) = 398600

```

State vector:

```

r (km)                = [766.265  5964.12  3583.57]
v (km/s)              = [-7.51882  0.706233  0.42431]

Angular momentum (km^2/s) = 52946.7
Eccentricity           = 0.00474691
Right ascension (deg)  = 360
Inclination (deg)     = 30.9997
Argument of perigee (deg) = 90.3282
True anomaly (deg)    = 353.388
Semimajor axis (km):  = 7033.16
Period:
  Seconds              = 5869.98
  Minutes              = 97.833
  Hours                = 1.63055
  Days                 = 0.0679396

```

-----

**Problem 5.22** The following MATLAB script uses the given three tracking site position vectors ( $\mathbf{R}_1, \mathbf{R}_2, \mathbf{R}_3$ ) and three space object direction cosine vectors ( $\hat{\rho}_1, \hat{\rho}_2, \hat{\rho}_3$ ) together with the three observation times to find the state vector ( $\mathbf{r}, \mathbf{v}$ ) by means of *Algorithm 5.5* and then iteratively improve it using *Algorithm 5.6*. Both algorithms are implemented in the MATLAB M-function `gauss` in Appendix D.15. The output to the MATLAB Command Window is listed afterwards.

```

% ~~~~~
% Problem_5_22
% ~~~~~
%
% This program uses Algorithms 5.5 and 5.6 (Gauss's method) to compute
% the state vector from the angles only data provided in Problem 5.16.
%
% deg          - factor for converting between degrees and radians
% pi           - 3.1415926...
% mu           - gravitational parameter (km^3/s^2)
% t            - vector of observation times t1, t2, t3 (s)
% theta        - vector of local sidereal times for t1, t2, t3 (deg)
% R            - matrix of site position vectors at t1, t2, t3 (km)
% rho          - matrix of direction cosine vectors at t1, t2, t3
% r_old, v_old - the state vector without iterative improvement (km,
km/s)
% r, v        - the state vector with iterative improvement (km,
km/s)
%
% User M-function required: gauss
% -----

clear
global mu
deg = pi/180;
mu  = 398600;

%...Data declaration for Problem 5.22:
t    = [      0      60     120];

R    = [ -1825.96   3583.66   4933.54
        -1841.63   3575.63   4933.54
        -1857.25   3567.54   4933.54];

rho  = [-0.301687   0.200673   0.932049
        -0.793090  -0.210324   0.571640

```

```

        -0.873085  -0.362969  0.325539];
%...

%...Algorithms 5.5 and 5.6:
[r, v, r_old, v_old] = gauss(rho(1,:), rho(2,:), rho(3,:), ...
                             R(1,:), R(2,:), R(3,:), ...
                             t(1), t(2), t(3));

%...Echo the input data and output the solution to
% the command window:
fprintf('-----\n')
fprintf('\n Problems 5.22 and 5.23: Orbit determination')
fprintf('\n                               by the Gauss method\n')
fprintf('\n Gravitational parameter (km^3/s^2) = %g', mu)
fprintf('\n\n Input data:\n');
fprintf('\n Site position vector (R) and space object')
fprintf('\n direction cosine vector (rho) at three times:\n')
for i = 1:3
    fprintf('\n t = %g s:\n',t(i))
    fprintf('\n R = [%g %g %g]', R(i,1), R(i,2), R(i,3))
    fprintf('\n rho = [%g %g %g]', rho(i,1), rho(i,2), rho(i,3))
    disp(' ')
end
fprintf('\n\n Solution:\n')
fprintf('\n Without iterative improvement (Problem 5.22)...\n')
fprintf('\n r (km) = [%g, %g, %g]', r_old(1), r_old(2), r_old(3))
fprintf('\n v (km/s) = [%g, %g, %g]', v_old(1), v_old(2), v_old(3))
fprintf('\n');
fprintf('\n\n With iterative improvement (Problem 5.23)...\n')
fprintf('\n r (km) = [%g, %g, %g]', r(1), r(2), r(3))
fprintf('\n v (km/s) = [%g, %g, %g]', v(1), v(2), v(3))
fprintf('\n-----\n')

```

```

-----
Problems 5.22 and 5.23: Orbit determination
                               by the Gauss method

```

```

Gravitational parameter (km^3/s^2) = 398600

```

```

Input data:

```

```

Site position vector (R) and space object
direction cosine vector (rho) at three times:

```

```

t = 0 s:

```

```

R = [-1825.96  3583.66  4933.54]
rho = [-0.301687  0.200673  0.932049]

```

```

t = 60 s:

```

```

R = [-1841.63  3575.63  4933.54]
rho = [-0.79309  -0.210324  0.57164]

```

```

t = 120 s:

```

```

R = [-1857.25  3567.54  4933.54]
rho = [-0.873085  -0.362969  0.325539]

```

```

Solution:

```

Without iterative improvement (Problem 5.22)...

$$\begin{aligned} \mathbf{r} \text{ (km)} &= [-2350.74, 3440.62, 5300.49] \\ \mathbf{v} \text{ (km/s)} &= [-6.61345, -3.88226, -0.413321] \end{aligned}$$

With iterative improvement (Problem 5.23)...

$$\begin{aligned} \mathbf{r} \text{ (km)} &= [-2351.59, 3440.39, 5301.1] \\ \mathbf{v} \text{ (km/s)} &= [-6.62403, -3.8885, -0.414013] \end{aligned}$$

Approximate state vector:

$$\mathbf{r} = -2350.74\hat{\mathbf{i}} + 3440.62\hat{\mathbf{j}} + 5300.49\hat{\mathbf{k}} \text{ (km)} \quad \mathbf{v} = -6.61345\hat{\mathbf{i}} - 3.88226\hat{\mathbf{j}} - 0.413321\hat{\mathbf{k}} \text{ (km/s)}$$

**Problem 5.23** From the MATLAB output listed in the previous problem solution, the iteratively improved state vector is

$$\mathbf{r} = -2351.59\hat{\mathbf{i}} + 3440.39\hat{\mathbf{j}} + 5301.1\hat{\mathbf{k}} \text{ (km)} \quad \mathbf{v} = -6.62403\hat{\mathbf{i}} - 3.8885\hat{\mathbf{j}} - 0.414013\hat{\mathbf{k}} \text{ (km/s)}$$

**Problem 5.24** The following MATLAB script uses  $\mathbf{r}$  and  $\mathbf{v}$  from Problem 5.23 to compute the orbital elements by means of *Algorithm 4.1*, which is implemented as the M-function `coe_from_sv` in Appendix D.8. The output to the MATLAB Command Window is listed afterwards.

```
%
% ~~~~~
% Problem_5_24
% ~~~~~
%
% This program uses Algorithm 4.1 to obtain the orbital
% elements from the state vector obtained in Problem 5.23.
%
% pi    - 3.1415926...
% deg   - factor for converting between degrees and radians
% mu    - gravitational parameter (km^3/s^2)
% r     - position vector (km) in the geocentric equatorial frame
% v     - velocity vector (km/s) in the geocentric equatorial frame
% coe   - orbital elements [h e RA incl w TA a]
%        where h    = angular momentum (km^2/s)
%                e    = eccentricity
%                RA   = right ascension of the ascending node (rad)
%                incl = orbit inclination (rad)
%                w    = argument of perigee (rad)
%                TA   = true anomaly (rad)
%                a    = semimajor axis (km)
% T     - Period of an elliptic orbit (s)
%
% User M-function required: coe_from_sv
% -----
%
clear
global mu
deg = pi/180;
mu = 398600;

%...Data declaration for Problem 5.24:
r = [-2351.59, 3440.39, 5301.1];
v = [-6.62403, -3.8885, -0.414013];
```

```

%...

%...Algorithm 4.1:
coe = coe_from_sv(r,v);

%...Echo the input data and output results to the command window:
fprintf('-----\n')
fprintf('\n Problem 5.24: Orbital elements from state vector\n')
fprintf('\n Gravitational parameter (km^3/s^2) = %g\n', mu)
fprintf('\n State vector:\n')
fprintf('\n r (km)                = [%g %g %g]', ...
        r(1), r(2), r(3))
fprintf('\n v (km/s)              = [%g %g %g]', ...
        v(1), v(2), v(3))

disp(' ')
fprintf('\n Angular momentum (km^2/s) = %g', coe(1))
fprintf('\n Eccentricity                = %g', coe(2))
fprintf('\n Right ascension (deg)         = %g', coe(3)/deg)
fprintf('\n Inclination (deg)             = %g', coe(4)/deg)
fprintf('\n Argument of perigee (deg)     = %g', coe(5)/deg)
fprintf('\n True anomaly (deg)           = %g', coe(6)/deg)
fprintf('\n Semimajor axis (km):         = %g', coe(7))

%...if the orbit is an ellipse, output its period (Equation 2.73):
if coe(2)<1
    T = 2*pi/sqrt(mu)*coe(7)^1.5;
    fprintf('\n Period:')
    fprintf('\n   Seconds                = %g', T)
    fprintf('\n   Minutes                 = %g', T/60)
    fprintf('\n   Hours                   = %g', T/3600)
    fprintf('\n   Days                    = %g', T/24/3600)
end
fprintf('\n-----\n')

```

-----  
Problem 5.24: Orbital elements from state vector

Gravitational parameter (km<sup>3</sup>/s<sup>2</sup>) = 398600

State vector:

r (km) = [-2351.59 3440.39 5301.1]  
v (km/s) = [-6.62403 -3.8885 -0.414013]

Angular momentum (km<sup>2</sup>/s) = 51868.3  
Eccentricity = 0.000957299  
Right ascension (deg) = 28.0006  
Inclination (deg) = 51.9999  
Argument of perigee (deg) = 88.9231  
True anomaly (deg) = 4.99817  
Semimajor axis (km): = 6749.43  
Period:  
Seconds = 5518.38  
Minutes = 91.973  
Hours = 1.53288  
Days = 0.0638701

-----

---

**Problems 5.25** The following MATLAB script uses Equations 5.55 and 5.56 to convert the data given in Problem 5.25 into three tracking site position vectors ( $\mathbf{R}_1, \mathbf{R}_2, \mathbf{R}_3$ ) and three space object direction cosine vectors ( $\hat{\rho}_1, \hat{\rho}_2, \hat{\rho}_3$ ). These vectors together with the three observation times are then

handed off to the M-function `gauss` (Appendix D.15). `gauss` implements both the Gauss *Algorithm 5.5* to compute an approximation of the state vector  $(\mathbf{r}, \mathbf{v})$  and *Algorithm 5.6*, which iteratively improves it. The output to the MATLAB Command Window is listed afterwards.

```
% ~~~~~
% Problem_5_25
% ~~~~~
%
% This program uses Algorithms 5.5 and 5.6 (Gauss's method) to compute
% the state vector from the angles only data provided in Problem 5.25.
%
% deg          - factor for converting between degrees and radians
% pi           - 3.1415926...
% mu           - gravitational parameter (km^3/s^2)
% Re          - earth's equatorial radius (km)
% f           - earth's flattening factor
% H           - elevation of observation site (km)
% phi         - latitude of site (deg)
% t           - vector of observation times t1, t2, t3 (s)
% ra          - vector of topocentric equatorial right ascensions
%             - at t1, t2, t3 (deg)
% dec         - vector of topocentric equatorial right declinations
%             - at t1, t2, t3 (deg)
% theta       - vector of local sidereal times for t1, t2, t3 (deg)
% R           - matrix of site position vectors at t1, t2, t3 (km)
% rho        - matrix of direction cosine vectors at t1, t2, t3
% fac1, fac2  - common factors
% r_old, v_old - the state vector without iterative improvement (km,
km/s)
% r, v       - the state vector with iterative improvement (km,
km/s)
%
% User M-function required: gauss
% -----

clear

global mu

deg = pi/180;
mu  = 398600;
Re  = 6378;
f   = 1/298.26;

%...Data declaration for Problem 5.25:
H   = 0.5;
phi = 60*deg;
t   = [ 0      300      600];
ra  = [157.783 159.221 160.526]*deg;
dec = [24.2403 27.2993 29.8982]*deg;
theta = [ 150 151.253 152.507]*deg;
%...

%...Equations 5.56, 5.57:
fac1 = Re/sqrt(1-(2*f - f*f)*sin(phi)^2);
fac2 = (Re*(1-f)^2/sqrt(1-(2*f - f*f)*sin(phi)^2) + H)*sin(phi);
for i = 1:3
    R(i,1) = (fac1 + H)*cos(phi)*cos(theta(i));
    R(i,2) = (fac1 + H)*cos(phi)*sin(theta(i));
    R(i,3) = fac2;
    rho(i,1) = cos(dec(i))*cos(ra(i));
```



```

    rho(i,2) = cos(dec(i))*sin(ra(i));
    rho(i,3) = sin(dec(i));
end

%...Algorithms 5.5 and 5.6:
[r, v, r_old, v_old] = gauss(rho(1,:), rho(2,:), rho(3,:), ...
                             R(1,:), R(2,:), R(3,:), ...
                             t(1), t(2), t(3));

%...Echo the input data and output the solution to
% the command window:
fprintf('-----\n')
fprintf('\n Problems 5.25 and 5.26: Orbit determination')
fprintf('\n          by the Gauss method\n')
fprintf('\n Radius of earth (km)          = %g', Re)
fprintf('\n Flattening factor              = %g', f)
fprintf('\n Gravitational parameter (km^3/s^2) = %g', mu)
fprintf('\n\n Input data:\n');
fprintf('\n Latitude (deg) of tracking site = %g', phi/deg);
fprintf('\n Altitude (km) above sea level   = %g', H);
fprintf('\n\n Observations:')
fprintf('\n          Right')
fprintf('          Local')
fprintf('\n Time (s)  Ascension (deg)  Declination (deg)')
fprintf(' Sidereal time (deg)')
for i = 1:3
    fprintf('\n %9.4g %11.4f %19.4f %20.4f', ...
           t(i), ra(i)/deg, dec(i)/deg, theta(i)/deg)
end

fprintf('\n\n Solution:\n')

fprintf('\n Without iterative improvement (Problem 5.25)... \n')
fprintf('\n r (km)   = [%g, %g, %g]', r_old(1), r_old(2), r_old(3))
fprintf('\n v (km/s) = [%g, %g, %g]', v_old(1), v_old(2), v_old(3))
fprintf('\n');
fprintf('\n\n With iterative improvement (Problem 5.26)... \n')
fprintf('\n r (km)   = [%g, %g, %g]', r(1), r(2), r(3))
fprintf('\n v (km/s) = [%g, %g, %g]', v(1), v(2), v(3))
fprintf('\n-----\n')

```

```

-----
Problems 5.25 and 5.26: Orbit determination
          by the Gauss method

```

```

Radius of earth (km)          = 6378
Flattening factor              = 0.00335278
Gravitational parameter (km^3/s^2) = 398600

```

Input data:

```

Latitude (deg) of tracking site = 60
Altitude (km) above sea level   = 0.5

```

Observations:

	Right		Local
Time (s)	Ascension (deg)	Declination (deg)	Sidereal time
(deg)			
0	157.7830	24.2403	150.0000
300	159.2210	27.2993	151.2530
600	160.5260	29.8982	152.5070

Solution:

Without iterative improvement (Problem 5.25)...

$$\begin{aligned} \mathbf{r} \text{ (km)} &= [-19050.2, 7702.56, 14469.6] \\ \mathbf{v} \text{ (km/s)} &= [-3.27477, -0.482844, 5.07464] \end{aligned}$$

With iterative improvement (Problem 5.26)...

$$\begin{aligned} \mathbf{r} \text{ (km)} &= [-19081, 7714.25, 14486.6] \\ \mathbf{v} \text{ (km/s)} &= [-3.27846, -0.484358, 5.08206] \end{aligned}$$

Approximate state vector:

$$\mathbf{r} = -19050.2\hat{\mathbf{I}} + 7702.56\hat{\mathbf{J}} + 14469.6\hat{\mathbf{K}} \text{ (km)} \quad \mathbf{v} = -3.27477\hat{\mathbf{I}} - 0.482844\hat{\mathbf{J}} + 5.07464\hat{\mathbf{K}} \text{ (km/s)}$$

**Problem 5.26** From the MATLAB output listed in the previous problem solution, the iteratively improved state vector is

$$\mathbf{r} = -19081\hat{\mathbf{I}} + 7714.25\hat{\mathbf{J}} + 14486.6\hat{\mathbf{K}} \text{ (km)} \quad \mathbf{v} = -3.27846\hat{\mathbf{I}} - 0.484358\hat{\mathbf{J}} + 5.08206\hat{\mathbf{K}} \text{ (km/s)}$$

**Problem 5.27** The following MATLAB script uses  $\mathbf{r}$  and  $\mathbf{v}$  from Problem 5.26 to compute the orbital elements by means of *Algorithm 4.1*, which is implemented as the M-function `coe_from_sv` in Appendix D.8. The output to the MATLAB Command Window is listed afterwards.

```
% ~~~~~
% Problem_5_27
% ~~~~~
%
% This program uses Algorithm 4.1 to obtain the orbital
% elements from the state vector obtained in Problem 5.26.
%
% pi    - 3.1415926...
% deg   - factor for converting between degrees and radians
% mu    - gravitational parameter (km^3/s^2)
% r     - position vector (km) in the geocentric equatorial frame
% v     - velocity vector (km/s) in the geocentric equatorial frame
% coe   - orbital elements [h e RA incl w TA a]
%       where h    = angular momentum (km^2/s)
%               e    = eccentricity
%               RA  = right ascension of the ascending node (rad)
%               incl = orbit inclination (rad)
%               w   = argument of perigee (rad)
%               TA  = true anomaly (rad)
%               a   = semimajor axis (km)
% T     - Period of an elliptic orbit (s)
%
% User M-function required: coe_from_sv
% -----

clear
global mu
deg = pi/180;
mu = 398600;

%...Data declaration for Problem 5.27:
r = [ -19081, 7714.25, 14486.6];
v = [-3.27846, -0.484358, 5.08206];
%...
```

```

%...Algorithm 4.1:
coe = coe_from_sv(r,v);

%...Echo the input data and output results to the command window:
fprintf('-----\n')
fprintf('\n Problem 5.27: Orbital elements from state vector\n')
fprintf('\n Gravitational parameter (km^3/s^2) = %g\n', mu)
fprintf('\n State vector:\n')
fprintf('\n r (km)                = [%g %g %g]', ...
        r(1), r(2), r(3))
fprintf('\n v (km/s)              = [%g %g %g]', ...
        v(1), v(2), v(3))

disp(' ')
fprintf('\n Angular momentum (km^2/s) = %g', coe(1))
fprintf('\n Eccentricity                = %g', coe(2))
fprintf('\n Right ascension (deg)         = %g', coe(3)/deg)
fprintf('\n Inclination (deg)             = %g', coe(4)/deg)
fprintf('\n Argument of perigee (deg)     = %g', coe(5)/deg)
fprintf('\n True anomaly (deg)           = %g', coe(6)/deg)
fprintf('\n Semimajor axis (km):         = %g', coe(7))

%...if the orbit is an ellipse, output its period (Equation 2.73):
if coe(2)<1
    T = 2*pi/sqrt(mu)*coe(7)^1.5;
    fprintf('\n Period:')
    fprintf('\n   Seconds                = %g', T)
    fprintf('\n   Minutes                 = %g', T/60)
    fprintf('\n   Hours                   = %g', T/3600)
    fprintf('\n   Days                    = %g', T/24/3600)
end
fprintf('\n-----\n')

```

```
-----
Problem 5.27: Orbital elements from state vector
```

```
Gravitational parameter (km^3/s^2) = 398600
```

```
State vector:
```

```
r (km)                = [-19081  7714.25  14486.6]
v (km/s)              = [-3.27846  -0.484358  5.08206]
```

```
Angular momentum (km^2/s) = 76005.8
Eccentricity                = 1.08937
Right ascension (deg)       = 136.949
Inclination (deg)           = 62.9772
Argument of perigee (deg)   = 287.335
True anomaly (deg)          = 112.915
Semimajor axis (km):        = -77612.3
```

---

**Problem 5.28** The following MATLAB script uses the given three tracking site position vectors ( $\mathbf{R}_1, \mathbf{R}_2, \mathbf{R}_3$ ) and three space object direction cosine vectors ( $\hat{\mathbf{p}}_1, \hat{\mathbf{p}}_2, \hat{\mathbf{p}}_3$ ) together with the three observation times to find the state vector ( $\mathbf{r}, \mathbf{v}$ ) by means of *Algorithm 5.5* and then iteratively improve it using *Algorithm 5.6*. Both algorithms are implemented in the MATLAB M-function `gauss` in Appendix D.15. The output to the MATLAB Command Window is listed afterwards.

```

% ~~~~~
% Problem_5_28
% ~~~~~
%

```

```

% This program uses Algorithms 5.5 and 5.6 (Gauss's method) to compute
% the state vector from the angles only data provided in Problem 5.28.
%
% deg          - factor for converting between degrees and radians
% pi           - 3.1415926...
% mu           - gravitational parameter (km^3/s^2)
% t            - vector of observation times t1, t2, t3 (s)
% theta        - vector of local sidereal times for t1, t2, t3 (deg)
% R            - matrix of site position vectors at t1, t2, t3 (km)
% rho          - matrix of direction cosine vectors at t1, t2, t3
% r_old, v_old - the state vector without iterative improvement (km,
km/s)
% r, v         - the state vector with iterative improvement (km,
km/s)
%
% User M-function required: gauss
% -----

clear
global mu
deg = pi/180;
mu = 398600;

%...Data declaration for Problem 5.28:
t = [ 0 300 600];

R = [ 5582.84 0 3073.90
      5581.50 122.122 3073.90
      5577.50 244.186 3073.90];

rho = [ 0.846428, 0, 0.532504
        0.749290, 0.463023, 0.473470
        0.529447, 0.777163, 0.340152];

%...

%...Algorithms 5.5 and 5.6:
[r, v, r_old, v_old] = gauss(rho(1,:), rho(2,:), rho(3,:), ...
                             R(1,:), R(2,:), R(3,:), ...
                             t(1), t(2), t(3));

%...Echo the input data and output the solution to
% the command window:
fprintf('-----')
fprintf('\n Problems 5.28 and 5.29: Orbit determination')
fprintf('\n by the Gauss method\n')
fprintf('\n Gravitational parameter (km^3/s^2) = %g', mu)
fprintf('\n\n Input data:\n');
fprintf('\n Site position vector (R) and space object')
fprintf('\n direction cosine vector (rho) at three times:\n')
for i = 1:3
    fprintf('\n t = %g s:\n',t(i))
    fprintf('\n R = [%g %g %g]', R(i,1), R(i,2), R(i,3))
    fprintf('\n rho = [%g %g %g]', rho(i,1), rho(i,2), rho(i,3))
    disp(' ')
end
fprintf('\n\n Solution:\n')
fprintf('\n Without iterative improvement (Problem 5.28)...\n')
fprintf('\n r (km) = [%g, %g, %g]', r_old(1), r_old(2), r_old(3))
fprintf('\n v (km/s) = [%g, %g, %g]', v_old(1), v_old(2), v_old(3))
fprintf('\n');
fprintf('\n\n With iterative improvement (Problem 5.29)...\n')
fprintf('\n r (km) = [%g, %g, %g]', r(1), r(2), r(3))
fprintf('\n v (km/s) = [%g, %g, %g]', v(1), v(2), v(3))

```

```
fprintf('\n-----\n')
```

```
-----
Problems 5.28 and 5.29: Orbit determination
                        by the Gauss method
```

```
Gravitational parameter (km^3/s^2) = 398600
```

```
Input data:
```

```
Site position vector (R) and space object
direction cosine vector (rho) at three times:
```

```
t = 0 s:
```

```
R   = [5582.84  0  3073.9]
rho = [0.846428  0  0.532504]
```

```
t = 300 s:
```

```
R   = [5581.5  122.122  3073.9]
rho = [0.74929  0.463023  0.47347]
```

```
t = 600 s:
```

```
R   = [5577.5  244.186  3073.9]
rho = [0.529447  0.777163  0.340152]
```

```
Solution:
```

```
Without iterative improvement (Problem 5.28)...
```

```
r (km)   = [8282.6, 1791.26, 4780.7]
v (km/s) = [-1.07108, 5.89508, -0.618321]
```

```
With iterative improvement (Problem 5.29)...
```

```
r (km)   = [8306.27, 1805.89, 4795.66]
v (km/s) = [-1.07872, 5.94219, -0.622807]
```

Approximate state vector

$$\mathbf{r} = 8282.6\hat{\mathbf{I}} + 1791.26\hat{\mathbf{J}} + 4780.7\hat{\mathbf{K}} \text{ (km)} \quad \mathbf{v} = -1.07108\hat{\mathbf{I}} + 5.89508\hat{\mathbf{J}} - 0.618321\hat{\mathbf{K}} \text{ (km/s)}$$

**Problem 5.29** From the MATLAB output listed in the previous problem solution, the iteratively improved state vector is

$$\mathbf{r} = 8306.27\hat{\mathbf{I}} + 1805.89\hat{\mathbf{J}} + 4795.66\hat{\mathbf{K}} \text{ (km)} \quad \mathbf{v} = -1.07872\hat{\mathbf{I}} + 5.94219\hat{\mathbf{J}} - 0.622807\hat{\mathbf{K}} \text{ (km/s)}$$

**Problem 5.30** The following MATLAB script uses  $\mathbf{r}$  and  $\mathbf{v}$  from Problem 5.29 to compute the orbital elements by means of *Algorithm 4.1*, which is implemented as the M-function `coe_from_sv` in Appendix D.8. The output to the MATLAB Command Window is listed afterwards.

```
%
%
% Problem_5_30
% ~~~~~
```

```

%
% This program uses Algorithm 4.1 to obtain the orbital
% elements from the state vector obtained in Problem 5.29.
%
% pi    - 3.1415926...
% deg   - factor for converting between degrees and radians
% mu    - gravitational parameter (km^3/s^2)
% r     - position vector (km) in the geocentric equatorial frame
% v     - velocity vector (km/s) in the geocentric equatorial frame
% coe   - orbital elements [h e RA incl w TA a]
%        where h    = angular momentum (km^2/s)
%                e    = eccentricity
%                RA  = right ascension of the ascending node (rad)
%                incl = orbit inclination (rad)
%                w   = argument of perigee (rad)
%                TA  = true anomaly (rad)
%                a   = semimajor axis (km)
% T     - Period of an elliptic orbit (s)
%
% User M-function required: coe_from_sv
% -----
-

clear
global mu
deg = pi/180;
mu = 398600;

%...Data declaration for Problem 5.30:
r = [ 8306.27, 1805.89, 4795.66];
v = [-1.07872, 5.94219, -0.622807];
%...

%...Algorithm 4.1:
coe = coe_from_sv(r,v);

%...Echo the input data and output results to the command window:
fprintf('-----\n')
fprintf('\n Problem 5.30: Orbital elements from state vector\n')
fprintf('\n Gravitational parameter (km^3/s^2) = %g\n', mu)
fprintf('\n State vector:\n')
fprintf('\n r (km)                = [%g %g %g]', ...
        r(1), r(2), r(3))
fprintf('\n v (km/s)              = [%g %g %g]', ...
        v(1), v(2), v(3))

disp(' ')
fprintf('\n Angular momentum (km^2/s) = %g', coe(1))
fprintf('\n Eccentricity                = %g', coe(2))
fprintf('\n Right ascension (deg)       = %g', coe(3)/deg)
fprintf('\n Inclination (deg)          = %g', coe(4)/deg)
fprintf('\n Argument of perigee (deg)   = %g', coe(5)/deg)
fprintf('\n True anomaly (deg)         = %g', coe(6)/deg)
fprintf('\n Semimajor axis (km):       = %g', coe(7))

%...if the orbit is an ellipse, output its period (Equation 2.73):
if coe(2)<1
    T = 2*pi/sqrt(mu)*coe(7)^1.5;
    fprintf('\n Period:')
    fprintf('\n   Seconds                = %g', T)
    fprintf('\n   Minutes                 = %g', T/60)
    fprintf('\n   Hours                   = %g', T/3600)
    fprintf('\n   Days                    = %g', T/24/3600)
end

```

```
fprintf('\n-----\n')
```

```
-----  
Problem 5.30: Orbital elements from state vector
```

```
Gravitational parameter (km3/s2) = 398600
```

```
State vector:
```

```
r (km)           = [8306.27  1805.89  4795.66]  
v (km/s)         = [-1.07872  5.94219  -0.622807]
```

```
Angular momentum (km2/s) = 59242.6  
Eccentricity         = 0.0995646  
Right ascension (deg) = 270  
Inclination (deg)    = 30.0002  
Argument of perigee (deg) = 269.945  
True anomaly (deg)   = 190.718  
Semimajor axis (km): = 8893.18  
Period:  
  Seconds           = 8346.36  
  Minutes           = 139.106  
  Hours             = 2.31843  
  Days              = 0.0966014
```

---

**Problem 6.1**

Orbit 1 (circle):

$$v_c = \sqrt{\frac{\mu}{r}} = \sqrt{\frac{398\,600}{6378 + 300}} = 7.726 \text{ km/s}$$

Orbit 2 (ellipse):

$$e = \frac{r_{\text{apogee}} - r_{\text{perigee}}}{r_{\text{apogee}} + r_{\text{perigee}}} = \frac{(6378 + 300) - (6378 + 200)}{(6378 + 300) + (6378 + 200)} = 0.003758$$

$$r_{\text{apogee}} = \frac{h^2}{\mu} \frac{1}{1 - e}$$

$$6378 + 300 = \frac{h^2}{398\,600} \frac{1}{1 - 0.003758} \Rightarrow h = 51\,500 \text{ km}^2/\text{s}$$

$$v_{\text{apogee}} = \frac{h}{r_{\text{apogee}}} = \frac{51\,500}{6678} = 7.711 \text{ km/s}$$

$$\Delta v = 7.726 - 7.711 = 0.01453 \text{ km/s} = 14.53 \text{ m/s}$$

(a)  $\text{Thrust} \cdot \Delta t = m \Delta v$

$$53\,400 \cdot \Delta t = 125\,000 \cdot 14.53 \Rightarrow \Delta t = 34.01 \text{ s}$$

$$v_{\text{avg}} = \frac{v_{\text{circle}} + (v_{\text{circle}} + \Delta v)}{2} = v_{\text{circle}} + \frac{\Delta v}{2} = 7.726 + \frac{14.53}{2} = 7.733 \text{ m/s}$$

(b)  $\Delta s = v_{\text{avg}} \Delta t = 7.733 \cdot 34.01 = \underline{263 \text{ km}}$

(c)  $\frac{\Delta s}{\text{orbit circumference}} = \frac{263}{2\pi \cdot 6600} = \underline{0.006268 \text{ or } 0.63\%}$

**Problem 6.2**

$$v_{\text{perigee}_1} = 8.2 \text{ km/s}$$

$$r_{\text{perigee}_1} = 6378 + 480 = 6858 \text{ km}$$

$$r_{\text{apogee}_2} = r_{\text{perigee}_1} = 6858 \text{ km}$$

$$r_{\text{perigee}_2} = 6378 + 160 = 6538 \text{ km}$$

$$e_2 = \frac{r_{\text{apogee}_2} - r_{\text{perigee}_2}}{r_{\text{apogee}_2} + r_{\text{perigee}_2}} = \frac{6858 - 6538}{6858 + 6538} = 0.02389$$

$$r_{\text{apogee}_2} = \frac{h_2^2}{\mu} \frac{1}{1 - e_2}$$

$$6858 = \frac{h_2^2}{398\,600} \frac{1}{1 - 0.02389} \Rightarrow h_2 = 51\,660 \text{ km}^2/\text{s}$$

$$v_{\text{apogee}_2} = \frac{h_2}{r_{\text{apogee}_2}} = \frac{51\,660}{6858} = 7.532 \text{ km/s}$$

$$\Delta v = v_{\text{apogee}_2} - v_{\text{perigee}_1} = 7.532 - 8.2 = \underline{-0.6678 \text{ km/s}}$$



**Problem 6.3**

(a)

Orbit 1 (circle):

$$v_1 = \sqrt{\frac{\mu}{r}} = \sqrt{\frac{398\,600}{6378 + 300}} = 7.726 \text{ km/s}$$

Orbit 2 (transfer ellipse):

$$e_2 = \frac{r_{\text{apogee}_2} - r_{\text{perigee}_2}}{r_{\text{apogee}_2} + r_{\text{perigee}_2}} = \frac{(6378 + 3000) - (6378 + 300)}{(6378 + 3000) + (6378 + 300)} = 0.1682$$

$$r_{\text{perigee}_2} = \frac{h_2^2}{\mu} \frac{1}{1 + e_2}$$

$$6678 = \frac{h_2^2}{398\,600} \frac{1}{1 + 0.1682} \Rightarrow h_2 = 55760 \text{ km}^2/\text{s}$$

$$v_{\text{perigee}_2} = \frac{h_2}{r_{\text{perigee}_2}} = \frac{55760}{6678} = 8.35 \text{ km/s}$$

$$v_{\text{apogee}_2} = \frac{h_2}{r_{\text{apogee}_2}} = \frac{55760}{9378} = 5.946 \text{ km/s}$$

Orbit 3 (circle):

$$v_3 = \sqrt{\frac{\mu}{r}} = \sqrt{\frac{398\,600}{6378 + 3000}} = 6.519 \text{ km/s}$$

$$\Delta v_1 = v_{\text{perigee}_2} - v_1 = 8.350 - 7.726 = 0.6244 \text{ km/s}$$

$$\Delta v_2 = v_3 - v_{\text{apogee}_2} = 6.519 - 5.946 = 0.5734 \text{ km/s}$$

$$\Delta v_{\text{total}} = \Delta v_1 + \Delta v_2 = \underline{1.198 \text{ km/s}}$$

(b)

$$a_2 = \frac{1}{2} (r_{\text{perigee}_2} + r_{\text{apogee}_2}) = \frac{1}{2} (6678 + 9378) = 8028 \text{ km/s}$$

$$T_2 = \frac{2\pi}{\sqrt{\mu}} a^{3/2} = \frac{2\pi}{\sqrt{398\,600}} 8028^{3/2} = 7159 \text{ s (period of transfer ellipse)}$$

$$t_{\text{perigee to apogee}} = \frac{T_2}{2} = 3579 \text{ s} = \underline{59.65 \text{ m}}$$

**Problem 6.4** To determine where the projectile  $B$  impacts the earth we need the orbital elements.

$$r_{\text{apogee}_B} = 7000 \text{ km}$$

$$v_{\text{apogee}_B} = 7.1 \text{ km/s}$$

$$h_B = r_{\text{apogee}_B} v_{\text{apogee}_B} = 7000 \cdot 7.1 = 49700 \text{ km}^2/\text{s}$$

$$r_{\text{apogee}_B} = \frac{h_B^2}{\mu} \frac{1}{1 + e_B}$$

$$7000 = \frac{49700^2}{398\,600} \frac{1}{1 + e_B} \Rightarrow e_B = 0.1147$$

$$T_B = \frac{2\pi}{\mu^2} \left( \frac{h_B}{\sqrt{1 - e_B^2}} \right)^3 = \frac{2\pi}{398\,600^2} \left( \frac{49700}{\sqrt{1 - 0.1147^2}} \right)^3 = 4952 \text{ s (period of } B\text{'s orbit)}$$

At impact,  $r_B = R_{\text{earth}}$ .

$$R_{\text{earth}} = \frac{h_B^2}{\mu} \frac{1}{1 + e_B \cos \theta_{\text{impact}}} \quad (\text{At impact, } r_B = R_{\text{earth}})$$

$$6378 = \frac{49700^2}{398600} \frac{1}{1 + 0.1147 \cos \theta_{\text{impact}}} \Rightarrow \theta_{\text{impact}} = 104.3^\circ \quad (\text{from perigee of } B\text{'s elliptical orbit})$$

Determine the time of flight ( $t_{of}$ ) to impact by first finding  $t_{\text{impact}}$ , the time from perigee to  $B$ 's impact point.

$$\tan \frac{E_{\text{impact}}}{2} = \sqrt{\frac{1 - e_B}{1 + e_B}} \tan \frac{\theta_{\text{impact}}}{2} = \sqrt{\frac{1 - 0.1147}{1 + 0.1147}} \tan \frac{104.3^\circ}{2} \Rightarrow E_{\text{impact}} = 1.708 \text{ rad}$$

$$M_{\text{impact}} = E_{\text{impact}} - e_B \sin E_{\text{impact}} = 1.708 - 0.1147 \sin 1.708 = 1.594 \text{ rad}$$

$$t_{\text{impact}} = T_B \frac{M_{\text{impact}}}{2\pi} = 4952 \frac{1.594}{2\pi} = 1257 \text{ s (from impact point to perigee)}$$

Then

$$t_{of} = \frac{T_B}{2} - t_{\text{impact}} = \frac{4952}{2} - 1257 = 1220 \text{ s}$$

Find the orbital elements of spacecraft  $S$  trajectory.

$$r_{\text{perigee}_S} = 7000 \text{ km}$$

$$v_{\text{perigee}_S} = 1.3v_{\text{esc}} = 1.3 \sqrt{\frac{2\mu}{r_{\text{perigee}_S}}} = 1.3 \sqrt{\frac{2 \cdot 398600}{7000}} = 13.97 \text{ km/s}$$

$$h_S = r_{\text{perigee}_S} v_{\text{perigee}_S} = 7000 \cdot 13.97 = 97110 \text{ km}^2/\text{s}$$

$$r_{\text{perigee}_S} = \frac{h_S^2}{\mu} \frac{1}{1 + e_S}$$

$$7000 = \frac{97110^2}{398600} \frac{1}{1 + e_S} \Rightarrow e_S = 2.38$$

Location of  $S$  on its hyperbolic trajectory when  $B$  impacts the earth:

$$M_h = \frac{\mu^2}{h_S^3} (e_S^2 - 1)^{3/2} t_{of} = \frac{398600^2}{97110^3} \cdot (2.38^2 - 1)^{3/2} \cdot 1220 = 2.131 \text{ rad}$$

$$e_S \sinh F - F = M_h$$

$$2.38 \sinh F - F = 2.131 \Rightarrow F = 1.118 \quad (\text{Algorithm 3.2})$$

$$\tan \frac{\theta_S}{2} = \sqrt{\frac{e_S + 1}{e_S - 1}} \tanh \frac{F}{2} = \sqrt{\frac{2.38 + 1}{2.38 - 1}} \tanh \frac{1.118}{2} \Rightarrow \theta_S = 76.87^\circ$$

$$r_S = \frac{h_S^2}{\mu} \frac{1}{1 + e_S \cos \theta_S} = \frac{97110^2}{398600} \frac{1}{1 + 0.28 \cos 76.87^\circ} = 15360 \text{ km}$$

$$\text{distance} = r_S - 6378 = \underline{8978 \text{ km}}$$

### Problem 6.5

(a) For the transfer ellipse

$$a = \frac{1}{2}(r_{\text{Mars}} + r_{\text{earth}}) = \frac{1}{2}(227.9 + 149.6) \times 10^6 = 188.8 \times 10^6 \text{ km}$$

$$T = \frac{2\pi}{\sqrt{\mu}} a^{3/2} = \frac{2\pi}{\sqrt{132.7 \times 10^9}} (188.8 \times 10^6)^{3/2} = 44.73 \times 10^6 \text{ s} = 517.7 \text{ days}$$

$$\text{tof} = \frac{T}{2} = \underline{258.8 \text{ days}} \text{ (time of flight from earth to Mars)}$$

(b) Period of Mars in its orbit,

$$T_{\text{Mars}} = \frac{2\pi}{\sqrt{\mu}} r_{\text{Mars}}^{3/2} = \frac{2\pi}{\sqrt{132.7 \times 10^9}} (227.9 \times 10^6)^{3/2} = 59.34 \times 10^6 \text{ s} = 686.8 \text{ days}$$

$$\therefore \frac{180^\circ - \alpha}{180^\circ} = \frac{\text{tof}}{\frac{T_{\text{Mars}}}{2}} = \frac{258.8}{343.4} = 0.7537$$

$$\alpha = 44.33^\circ$$

### Problem 6.6

$$r_A = 7000 \text{ km} \quad r_C = 32000 \text{ km}$$

$$e_1 = 0.3$$

$$e_1 = \frac{r_B - r_A}{r_B + r_A}$$

$$0.3 = \frac{r_B - 7000}{r_B + 7000} \Rightarrow r_B = 13000 \text{ km}$$

$$e_2 = 0.5$$

$$e_2 = \frac{r_D - r_C}{r_D + r_C}$$

$$0.5 = \frac{r_D - 32000}{r_D + 32000} \Rightarrow r_D = 96000 \text{ km}$$

$$h_1 = \sqrt{2\mu} \sqrt{\frac{r_A r_B}{r_A + r_B}} = \sqrt{2 \cdot 398600} \sqrt{\frac{7000 \cdot 13000}{7000 + 13000}} = 60230 \text{ km}^2/\text{s}$$

$$h_2 = \sqrt{2\mu} \sqrt{\frac{r_C r_D}{r_C + r_D}} = \sqrt{2 \cdot 398600} \sqrt{\frac{32000 \cdot 96000}{32000 + 96000}} = 138300 \text{ km}^2/\text{s}$$

$$h_3 = \sqrt{2\mu} \sqrt{\frac{r_A r_D}{r_A + r_D}} = \sqrt{2 \cdot 398600} \sqrt{\frac{7000 \cdot 96000}{7000 + 96000}} = 72120 \text{ km}^2/\text{s}$$

$$h_4 = \sqrt{2\mu} \sqrt{\frac{r_B r_C}{r_B + r_C}} = \sqrt{2 \cdot 398600} \sqrt{\frac{13000 \cdot 32000}{13000 + 32000}} = 85850 \text{ km}^2/\text{s}$$

$$v_{A1} = \frac{h_1}{r_A} = \frac{60230}{7000} = 8.604 \text{ km/s}$$

$$v_{A3} = \frac{h_3}{r_A} = \frac{72120}{7000} = 10.3 \text{ km/s}$$

$$v_{B1} = \frac{h_1}{r_B} = \frac{60230}{13000} = 4.633 \text{ km/s}$$

$$v_{B4} = \frac{h_4}{r_B} = \frac{85850}{13000} = 6.604 \text{ km/s}$$

$$v_{C2} = \frac{h_2}{r_C} = \frac{138300}{32000} = 4.323 \text{ km/s}$$

$$v_{C4} = \frac{h_4}{r_C} = \frac{85850}{32000} = 2.683 \text{ km/s}$$

$$v_{D2} = \frac{h_2}{r_D} = \frac{138300}{96000} = 1.441 \text{ km/s}$$

$$v_{D3} = \frac{h_3}{r_D} = \frac{72120}{96000} = 0.7512 \text{ km/s}$$

$$T_3 = \frac{2\pi}{\sqrt{\mu}} \left( \frac{r_A + r_D}{2} \right)^{3/2} = \frac{2\pi}{\sqrt{398\,600}} \left( \frac{7\,000 + 96\,000}{2} \right)^{3/2} = 116\,300 \text{ s} = 32.31 \text{ h}$$

$$T_4 = \frac{2\pi}{\sqrt{\mu}} \left( \frac{r_B + r_C}{2} \right)^{3/2} = \frac{2\pi}{\sqrt{398\,600}} \left( \frac{13\,000 + 32\,000}{2} \right)^{3/2} = 33\,590 \text{ s} = 9.33 \text{ h}$$

(a) Transfer orbit 3:

$$\Delta v_A = v_{A3} - v_{A1} = 10.3 - 8.604 = 1.699 \text{ km/s}$$

$$\Delta v_D = v_{D2} - v_{D3} = 1.441 - 0.7512 = 0.6896 \text{ km/s}$$

$$\Delta v_{\text{total}} = \Delta v_A + \Delta v_D = \underline{2.389 \text{ km/s}}$$

$$tof_3 = \frac{T_3}{2} = \frac{32.32}{2} = \underline{16.15 \text{ h}}$$

(b) Transfer orbit 4:

$$\Delta v_B = v_{B4} - v_{B1} = 6.604 - 4.633 = 1.971 \text{ km/s}$$

$$\Delta v_C = v_{C2} - v_{C4} = 4.323 - 2.683 = 1.64 \text{ km/s}$$

$$\Delta v_{\text{total}} = \Delta v_B + \Delta v_C = \underline{3.611 \text{ km/s}}$$

$$tof_4 = \frac{T_4}{2} = \frac{9.33}{2} = \underline{4.665 \text{ h}}$$

**Problem 6.7** Orbit 1 is the original circular orbit and orbit 2 is the impact trajectory.

$$v_{A1} = \sqrt{\frac{\mu}{r}} = \sqrt{\frac{398\,600}{6378 + 500}} = 7.613 \text{ km/s}$$

$$r_{\text{apogee}_2} = \frac{h_2^2}{\mu} \frac{1}{1 - e_2}$$

$$6378 + 500 = \frac{h_2^2}{\mu} \frac{1}{1 - e_2} \Rightarrow \frac{h_2^2}{\mu} = 6878(1 - e_2)$$

$$r_{B2} = \frac{h_2^2}{\mu} \frac{1}{1 + e_2 \cos \theta_B}$$

$$6378 = \frac{h_2^2}{\mu} \frac{1}{1 + e_2 \cos 60^\circ} \Rightarrow \frac{h_2^2}{\mu} = 6378(1 + 0.5e_2)$$

$$\frac{h_2^2}{\mu} = \frac{h_2^2}{\mu} \Rightarrow 6378(1 + 0.5e_2) = 6878(1 - e_2) \Rightarrow e_2 = 0.04967$$

$$\therefore h_2 = \sqrt{6878\mu(1 - e_2)} = \sqrt{6878 \cdot 398\,600 \cdot (1 - 0.04967)} = 51\,040 \text{ km}^2/\text{s}$$

(a)

$$v_{A2} = \frac{h_2}{r_A} = \frac{51\,040}{6878} = 7.421 \text{ km/s}$$

$$\Delta v = v_{A2} - v_{A1} = 7.421 - 7.613 = \underline{-0.1915 \text{ km/s}}$$

(b) To fall through the point directly below, we must remove completely the transverse component of velocity:

$$\Delta v = 0 - v_{A1} = \underline{-7.613 \text{ km/s}}$$

**Problem 6.8**  $A$  is apogee of impact trajectory,  $I$  is the impact point,  $a$  is the semimajor axis.

$$r_A = a(1 + e)$$

$$\therefore e = \frac{r_A}{a} - 1$$

From Equation 3.22,

$$\begin{aligned} r_I &= a(1 - e \cos E) \\ &= a \left[ 1 - \left( \frac{r_A}{a} - 1 \right) \cos E \right] \\ &= (1 + \cos E)a - r_A \cos E \end{aligned}$$

$$\therefore a = \frac{r_I + r_A \cos E}{1 + \cos E} \quad (2)$$

Substitute (2) into (1) to get

$$e = \frac{r_A}{\frac{r_I + r_A \cos E}{1 + \cos E}} - 1 = \frac{r_A - r_I}{r_A \cos E + r_I} \quad (3)$$

Mean anomaly of the impact point (measured ccw from perigee) is

$$M = 2\pi \frac{\left(\frac{T}{2} + t\right)}{T} = \pi + 2\pi \frac{t}{T} = \pi + 2\pi \frac{t}{\frac{2\pi}{\sqrt{\mu}} a^{3/2}} = \pi + \frac{\sqrt{\mu}t}{a^{3/2}}$$

Let  $f(E) = M - E + e \sin E$ . Then Kepler's equation is  $f(E) = 0$ .

$$f(E) = M - E + e \sin E$$

$$f(E) = \pi + \frac{\sqrt{\mu}t}{a^{3/2}} - E + e \sin E = \pi + \frac{\sqrt{\mu}t}{\left(\frac{r_i + r_a \cos E}{1 + \cos E}\right)^{3/2}} - E + \frac{r_a - r_i}{r_a \cos E + r_i} \sin E$$

Setting  $r_A = 6578$  km,  $r_I = 6378$  km,  $t = 30 \cdot 60 = 1800$  s,

$$f(E) = \pi + \frac{1136400}{\left(\frac{6378 + 6578 \cos E}{1 + \cos E}\right)^{3/2}} - E + \frac{200}{6578 \cos E + 6378} \sin E$$

Graphing  $f(E)$  reveals that  $f(E) = 0$  at  $E = 5.319$  rad. Substituting this into (1) and (2) yields

$$e = 0.01975 \quad a = 6451 \text{ km}$$

True anomaly of the impact point:

$$\tan \frac{\theta_I}{2} = \sqrt{\frac{1+e}{1-e}} \tan \frac{E_I}{2} = \sqrt{\frac{1+0.01975}{1-0.01975}} \tan \frac{5.319}{2} \Rightarrow \theta = 303.8^\circ \quad (123.8^\circ \text{ cw from apogee})$$

$$h = \sqrt{\mu a (1 - e^2)} = \sqrt{398600 \cdot 6451 \cdot (1 - 0.01975^2)} = 50700 \text{ km}^2/\text{s}$$

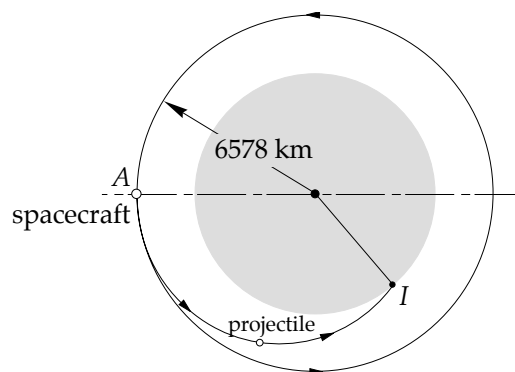

$$v_A = \frac{h}{r_A} = \frac{50700}{6578} = 7.707 \text{ km/s} \quad \text{velocity of projectile at apogee.}$$

$$v_c = \sqrt{\frac{\mu}{r}} = \sqrt{\frac{398600}{6578}} = 7.784 \text{ km/s} \quad \text{velocity of spacecraft in circular orbit.}$$

$$\Delta v = v_a - v_c = 7.707 - 7.784 = -0.07725 \text{ km/s}$$

### Problem 6.9

$$r_{\text{apogee}_1} = 6378 + 302 = 6680 \text{ km} \quad r_{\text{perigee}_1} = 6378 + 296 = 6674 \text{ km}$$

$$r_{\text{apogee}_2} = 6378 + 291 = 6669 \text{ km} \quad r_{\text{perigee}_2} = 6378 + 259 = 6637 \text{ km}$$

$$r_3 = 6378 + 259 = 6637 \text{ km}$$

$$r_{\text{apogee}_4} = 6378 + 255 = 6633 \text{ km} \quad r_{\text{perigee}_4} = 6378 + 194 = 6572 \text{ km}$$

$$h_1 = \sqrt{2\mu} \sqrt{\frac{r_{\text{apogee}_1} r_{\text{perigee}_1}}{r_{\text{apogee}_1} + r_{\text{perigee}_1}}} = \sqrt{2 \cdot 398600} \sqrt{\frac{6680 \cdot 6674}{6680 + 6674}} = 51590 \text{ km}^2/\text{s}$$

$$v_{\text{apogee}_1} = \frac{h_1}{r_{\text{apogee}_1}} = \frac{51590}{6680} = 7.723 \text{ km/s}$$

$$v_{\text{perigee}_1} = \frac{h_1}{r_{\text{perigee}_1}} = \frac{51590}{6674} = 7.730 \text{ km/s}$$

$$h_2 = \sqrt{2\mu} \sqrt{\frac{r_{\text{apogee}_2} r_{\text{perigee}_2}}{r_{\text{apogee}_2} + r_{\text{perigee}_2}}} = \sqrt{2 \cdot 398600} \sqrt{\frac{6669 \cdot 6637}{6669 + 6637}} = 51500 \text{ km}^2/\text{s}$$

$$v_{\text{apogee}_2} = \frac{h_2}{r_{\text{apogee}_2}} = \frac{51500}{6669} = 7.722 \text{ km/s}$$

$$v_{\text{perigee}_2} = \frac{h_2}{r_{\text{perigee}_2}} = \frac{51500}{6637} = 7.759 \text{ km/s}$$

$$v_3 = \sqrt{\frac{\mu}{r_3}} = \sqrt{\frac{398600}{6637}} = 7.750 \text{ km/s}$$

$$h_4 = \sqrt{2\mu} \sqrt{\frac{r_{\text{apogee}_4} r_{\text{perigee}_4}}{r_{\text{apogee}_4} + r_{\text{perigee}_4}}} = \sqrt{2 \cdot 398600} \sqrt{\frac{6633 \cdot 6572}{6633 + 6572}} = 51300 \text{ km}^2/\text{s}$$

$$v_{\text{apogee}_4} = \frac{h_4}{r_{\text{apogee}_4}} = \frac{51300}{6633} = 7.734 \text{ km/s}$$

$$v_{\text{perigee}_4} = \frac{h_4}{r_{\text{perigee}_4}} = \frac{51300}{6572} = 7.806 \text{ km/s}$$

Apogee of orbit 1 to perigee of orbit 2:

$$h_{12} = \sqrt{2\mu} \sqrt{\frac{r_{\text{apogee}_1} r_{\text{perigee}_2}}{r_{\text{apogee}_1} + r_{\text{perigee}_2}}} = \sqrt{2 \cdot 398600} \sqrt{\frac{6680 \cdot 6637}{6680 + 6637}} = 51520 \text{ km}^2/\text{s}$$

$$\Delta v_{12} = \left| \frac{h_{12}}{r_{\text{apogee}_1}} - v_{\text{apogee}_1} \right| + \left| \frac{h_{12}}{r_{\text{perigee}_2}} - v_{\text{perigee}_2} \right| = |7.712 - 7.723| + |7.762 - 7.759| = 0.01393 \text{ km/s}$$

Perigee of orbit 2 to orbit 3 (tangent):

$$\Delta v_{23} = v_{\text{perigee}_2} - v_3 = 7.759 - 7.750 = 0.009313 \text{ km/s}$$

Orbit 3 to perigee of orbit 4:

$$h_{34} = \sqrt{2\mu} \sqrt{\frac{r_3 r_{\text{perigee}_4}}{r_3 + r_{\text{perigee}_4}}} = \sqrt{2 \cdot 398600} \sqrt{\frac{6572 \cdot 6637}{6572 + 6637}} = 51310 \text{ km}^2/\text{s}$$

$$\Delta v_{34} = \left| \frac{h_{34}}{r_3} - v_3 \right| + \left| \frac{h_{34}}{r_{\text{perigee}_4}} - v_{\text{perigee}_4} \right| = |7.731 - 7.75| + |7.807 - 7.806| = 0.02026 \text{ km/s}$$

$$\Delta v_{\text{total}} = \Delta v_{12} + \Delta v_{23} + \Delta v_{34} = 0.01393 + 0.009313 + 0.02026 = \underline{0.04351 \text{ km/s}}$$

**Problem 6.10**  $r_A = 6878 \text{ km}$   $r_B = 7378 \text{ km}$

$$v_{A1} = \sqrt{\frac{\mu}{r_A}} = \sqrt{\frac{398600}{6878}} = 7.613 \text{ km/s}$$

$$h_2 = \sqrt{2\mu} \sqrt{\frac{r_A r_B}{r_A + r_B}} = \sqrt{2 \cdot 398600} \sqrt{\frac{6878 \cdot 7378}{6878 + 7378}} = 53270 \text{ km}^2/\text{s}$$

$$v_{A2} = \frac{h_2}{r_A} = \frac{53270}{6878} = 7.745 \text{ km/s}$$

$$v_{B2} = \frac{h_2}{r_B} = \frac{53270}{7378} = 7.220 \text{ km/s}$$

Alternatively, the energy equation,  $v^2/2 - \mu/r = -\mu/(2a)$ , implies

$$v = \sqrt{\left(\frac{2}{r} - \frac{1}{a}\right)\mu}$$

so that, since  $a = (r_A + r_B)/2 = 7128 \text{ km}$ ,

$$v_{A2} = \sqrt{\left(\frac{2}{r_A} - \frac{1}{a}\right)\mu} = \sqrt{\left(\frac{2}{6878} - \frac{1}{7128}\right) \cdot 398600} = 7.745 \text{ km/s}$$

$$v_{B2} = \sqrt{\left(\frac{2}{r_B} - \frac{1}{a}\right)\mu} = \sqrt{\left(\frac{2}{7378} - \frac{1}{7128}\right) \cdot 398600} = 7.220 \text{ km/s}$$

$$v_{B3} = \sqrt{\frac{\mu}{r_B}} = \sqrt{\frac{398600}{7378}} = 7.35 \text{ km/s}$$

$$\Delta v = |v_{A2} - v_{A1}| + |v_{B3} - v_{B2}| = 0.1323 + 0.1300 = \underline{0.2624 \text{ km/s}}$$

**Problem 6.11**

$$v_{A1} = \sqrt{\frac{\mu}{r}}$$

$$h_2 = \sqrt{2\mu} \sqrt{\frac{r(12r)}{r+12r}} = 1.359 \sqrt{\mu r}$$

$$v_{A2} = \frac{h_2}{r} = 1.359 \sqrt{\frac{\mu}{r}}$$

$$v_{B2} = \frac{h_2}{12r} = 0.1132\sqrt{\frac{\mu}{r}}$$

Alternatively, using the energy equation,

$$a_2 = \frac{r + 12r}{2} = 6.5r$$

$$v_{A2} = \sqrt{\left(\frac{2}{r} - \frac{1}{a_2}\right)\mu} = \sqrt{1.846\frac{\mu}{r}} = 1.359\sqrt{\frac{\mu}{r}}$$

$$v_{B2} = \sqrt{\left(\frac{2}{12r} - \frac{1}{a_2}\right)\mu} = \sqrt{0.01282\frac{\mu}{r}} = 0.1132\sqrt{\frac{\mu}{r}}$$

$$v_{B3} = \sqrt{\frac{\mu}{12r}} = 0.2887\sqrt{\frac{\mu}{r}}$$

$$\Delta v = |v_{A2} - v_{A1}| + |v_{B3} - v_{B2}| = 0.3587\sqrt{\frac{\mu}{r}} + 0.1754\sqrt{\frac{\mu}{r}} = \underline{0.5342\sqrt{\frac{\mu}{r}}}$$

### Problem 6.12

$$v_{A1} = \sqrt{\frac{\mu}{r}} \quad v_{A2} = \sqrt{\frac{2\mu}{r}} = 1.414\sqrt{\frac{\mu}{r}}$$

$$v_{B3} = \sqrt{\frac{2\mu}{12r}} = 0.4082\sqrt{\frac{\mu}{r}} \quad v_{B4} = \sqrt{\frac{\mu}{12r}} = 0.2887\sqrt{\frac{\mu}{r}}$$

$$\Delta v = |v_{A2} - v_{A1}| + |v_{B4} - v_{B3}| = 0.4142\sqrt{\frac{\mu}{r}} + 0.1196\sqrt{\frac{\mu}{r}} = \underline{0.5338\sqrt{\frac{\mu}{r}}}$$

### Problem 6.13

$$r_A = r \quad r_B = 3r$$

$$v_{A1} = v_1 = \sqrt{\frac{\mu}{r_A}} = \sqrt{\frac{\mu}{r}}$$

$$h_2 = \sqrt{2\mu} \sqrt{\frac{r_A r_B}{r_A + r_B}} = \sqrt{2\mu} \sqrt{\frac{r(3r)}{r + 3r}} = 1.225\sqrt{\mu r}$$

$$v_{A2} = \frac{h_2}{r_A} = \frac{1.225\sqrt{\mu r}}{r} = 1.225\sqrt{\frac{\mu}{r}} \quad (\text{Alternatively, use the energy equation.})$$

$$v_{B2} = \frac{h_2}{r_B} = \frac{1.225\sqrt{\mu r}}{3r} = 0.4082\sqrt{\frac{\mu}{r}}$$

$$v_{B3} = v_3 = \sqrt{\frac{\mu}{r_B}} = \sqrt{\frac{\mu}{3r}} = 0.5774\sqrt{\frac{\mu}{r}}$$

$$\Delta v = |v_{A2} - v_{A1}| + |v_{B3} - v_{B2}| = 0.2247\sqrt{\frac{\mu}{r}} + 0.1691\sqrt{\frac{\mu}{r}} = 0.3938\sqrt{\frac{\mu}{r}} = \underline{0.3938v_1}$$

### Problem 6.14

$$r_A = 6678 \text{ km} \quad r_C = 9378 \text{ km}$$

(a)

Orbit 1:

$$v_{A1} = \sqrt{\frac{\mu}{r_A}} = \sqrt{\frac{398\,600}{6678}} = 7.726 \text{ km/s}$$

Orbit 2:



$$\frac{r_B - r_A}{r_B + r_A} = e_2$$

$$\frac{r_B - 6678}{r_B + 6678} = 0.3 \Rightarrow r_B = 12402 \text{ km}$$

$$h_2 = \sqrt{2\mu} \sqrt{\frac{r_A r_B}{r_A + r_B}} = \sqrt{2 \cdot 398600} \sqrt{\frac{6678 \cdot 12402}{6678 + 12402}} = 58830 \text{ km}^2/\text{s}$$

$$v_{A2} = \frac{h_2}{r_A} = \frac{58830}{6678} = 8.809 \text{ km/s}$$

$$v_{B2} = \frac{h_2}{r_B} = \frac{58830}{12402} = 4.743 \text{ km/s}$$

Orbit 3:

$$h_3 = \sqrt{2\mu} \sqrt{\frac{r_B r_C}{r_B + r_C}} = \sqrt{2 \cdot 398600} \sqrt{\frac{12402 \cdot 9378}{12402 + 9378}} = 65250 \text{ km}^2/\text{s}$$

$$v_{B3} = \frac{h_3}{r_B} = \frac{65250}{12402} = 5.261 \text{ km/s}$$

$$v_{C3} = \frac{h_3}{r_C} = \frac{65250}{9378} = 6.957 \text{ km/s}$$

Orbit 4:

$$v_{C4} = \sqrt{\frac{\mu}{r_C}} = \sqrt{\frac{398600}{9378}} = 6.519 \text{ km/s}$$

$$\Delta v_{total} = |v_{A2} - v_{A1}| + |v_{B3} - v_{B2}| + |v_{C4} - v_{C3}| = 1.083 + 0.5177 + 0.4379 = \underline{2.039 \text{ km/s}}$$

(b)

$$T_2 = \frac{2\pi}{\sqrt{\mu}} \left( \frac{r_A + r_B}{2} \right)^{3/2} = \frac{2\pi}{\sqrt{398600}} \left( \frac{6678 + 12402}{2} \right)^{3/2} = 9273 \text{ s}$$

$$T_3 = \frac{2\pi}{\sqrt{\mu}} \left( \frac{r_B + r_C}{2} \right)^{3/2} = \frac{2\pi}{\sqrt{398600}} \left( \frac{12402 + 9378}{2} \right)^{3/2} = 11310 \text{ s}$$

$$t_{total} = \frac{1}{2}(T_1 + T_2) = 10290 \text{ s} = \underline{2.859 \text{ hr}}$$

**Problem 6.15**  $r_A = r_C = r_E = 15000 \text{ km}$   $r_B = 22000 \text{ km}$   $r_D = 6878 \text{ km}$ 

(a)

Orbit 1:

$$v_{A1} = \sqrt{\frac{\mu}{r_A}} = \sqrt{\frac{398600}{15000}} = 5.155 \text{ km/s}$$

$$\gamma_{A1} =$$

Orbit 2:

$$e_2 = \frac{r_B - r_D}{r_B + r_D} = \frac{22000 - 6878}{22000 + 6878} = 0.5237$$

$$h_2 = \sqrt{2\mu} \sqrt{\frac{r_B r_D}{r_B + r_D}} = \sqrt{2 \cdot 398600} \sqrt{\frac{22000 \cdot 6878}{22000 + 6878}} = 64630 \text{ km}^2/\text{s}$$

At the maneuvering point A:

$$r_A = \frac{h_2^2}{\mu} \frac{1}{1 + e_2 \cos \theta_A}$$

$$15000 = \frac{64630^2}{398600} \frac{1}{1 + 0.5237 \cos \theta_A} \Rightarrow \theta_A = 125.1^\circ$$

$$v_{A2})_{\perp} = \frac{h_2}{r_A} = \frac{64630}{15000} = 4.309 \text{ km/s}$$

$$v_{A2})_r = \frac{\mu}{h_2} e_2 \sin \theta_A = \frac{398600}{64630} 0.5237 \sin 125.1^\circ = 2.641 \text{ km/s}$$

$$v_{A2} = \sqrt{v_{A2})_{\perp}^2 + v_{A2})_r^2} = \sqrt{4.309^2 + 2.641^2} = 5.054 \text{ km/s}$$

$$\gamma_{A2} = \tan^{-1} \frac{v_{A2})_r}{v_{A2})_{\perp}} = \tan^{-1} \frac{2.641}{4.309} = 0.5499 \Rightarrow \gamma_{A2} = 31.51^\circ$$

$$\Delta\gamma_A = \gamma_{A2} - \gamma_{A1} = 31.51^\circ - 0 = 31.51^\circ$$

$$\Delta v_A = \sqrt{v_{A1}^2 + v_{A2}^2 - 2v_{A1}v_{A2} \cos \Delta\gamma_A} = \sqrt{5.155^2 + 5.054^2 - 25.1555 \cdot 0.54 \cos 31.51^\circ} = \underline{2.773 \text{ km/s T}}$$

(b)

Try Hohmann transfer (orbit 3) from point *E* on orbit 1 to point *B* on orbit 2.

$$h_3 = \sqrt{2\mu} \sqrt{\frac{r_E r_B}{r_E + r_B}} = \sqrt{2 \cdot 398600} \sqrt{\frac{15000 \cdot 22000}{15000 + 22000}} = 84320 \text{ km}^2/\text{s}$$

$$v_{E1} = v_{A1} = 5.155 \text{ km/s}$$

$$v_{E3} = \frac{h_3}{r_E} = \frac{84320}{15000} = 5.621 \text{ km/s}$$

$$v_{B3} = \frac{h_3}{r_B} = \frac{84320}{22000} = 3.833 \text{ km/s}$$

$$v_{B2} = \frac{h_2}{r_B} = \frac{64630}{22000} = 2.938 \text{ km/s}$$

$$\Delta v_{total} = |v_{E3} - v_{E1}| + |v_{B2} - v_{B3}| = 0.4665 + 0.985 = 1.362 \text{ km/s}$$

Try Hohmann transfer (orbit 4) from point *C* on orbit 1 to point *D* on orbit 2.

$$h_4 = \sqrt{2\mu} \sqrt{\frac{r_C r_D}{r_C + r_D}} = \sqrt{2 \cdot 398600} \sqrt{\frac{15000 \cdot 6878}{15000 + 6878}} = 61310 \text{ km}^2/\text{s}$$

$$v_{C1} = v_{A1} = 5.155 \text{ km/s}$$

$$v_{C4} = \frac{h_4}{r_C} = \frac{61310}{15000} = 4.088 \text{ km/s}$$

$$v_{D4} = \frac{h_4}{r_D} = \frac{61310}{6878} = 8.914 \text{ km/s}$$

$$v_{D2} = \frac{h_2}{r_D} = \frac{64630}{6878} = 9.397 \text{ km/s}$$

$$\Delta v_{total} = |v_{C4} - v_{C1}| + |v_{D2} - v_{D4}| = 1.067 + 0.4824 = 1.55 \text{ km/s}$$

This is larger than the total computed above; thus for minimum Hohmann transfer

$$\Delta v = 1.362 \text{ km/s}$$

---

**Problem 6.16**

Orbit 1:

$$r_{\text{perigee}_1} = 6378 + 1270 = 7648 \text{ km}$$

$$v_{\text{perigee}_1} = 9 \text{ km/s}$$

$$h_1 = r_{\text{perigee}_1} v_{\text{perigee}_1} = 7648 \cdot 9 = 68\,832 \text{ km}^2/\text{s}$$

$$r_{\text{perigee}_1} = \frac{h_1^2}{\mu} \frac{1}{1 + e_1}$$

$$7648 = \frac{68\,832^2}{398\,600} \frac{1}{1 + e_1} \Rightarrow e_1 = 0.5542$$

At the maneuver point,  $\theta = 100^\circ$ .

$$r = \frac{h_1^2}{\mu} \frac{1}{1 + e_1 \cos \theta} = \frac{68\,832^2}{398\,600} \frac{1}{1 + 0.5542 \cos 100^\circ} = 13\,150 \text{ km}$$

$$v_{1\perp} = \frac{h_1}{r} = \frac{68\,832}{13\,150} = 5.234 \text{ km/s}$$

$$v_{1r} = \frac{\mu}{h_1} e_1 \sin \theta = \frac{398\,600}{68\,832} 0.5542 \sin 100^\circ = 3.16 \text{ km/s}$$

$$v_1 = \sqrt{v_{1\perp}^2 + v_{1r}^2} = \sqrt{5.234^2 + 3.16^2} = 6.114 \text{ km/s}$$

$$\gamma_1 = \tan^{-1} \frac{v_{1r}}{v_{1\perp}} = \tan^{-1} \frac{3.16}{5.234} = 31.13$$

Orbit 2:

$$e_2 = 0.4$$

$$r = \frac{h_2^2}{\mu} \frac{1}{1 + e_2 \cos \theta}$$

$$13\,150 = \frac{h_2^2}{398\,600} \frac{1}{1 + 0.4 \cos 100^\circ} \Rightarrow h_2 = 69\,840 \text{ km}^2/\text{s}$$

$$v_{2\perp} = \frac{h_2}{r} = \frac{69\,840}{13\,150} = 5.311 \text{ km/s}$$

$$v_{2r} = \frac{\mu}{h_2} e_2 \sin \theta = \frac{398\,600}{69\,840} 0.4 \sin 100^\circ = 2.248 \text{ km/s}$$

$$v_2 = \sqrt{v_{2\perp}^2 + v_{2r}^2} = \sqrt{5.311^2 + 2.248^2} = 5.767 \text{ km/s}$$

$$\gamma_2 = \tan^{-1} \frac{v_{2r}}{v_{2\perp}} = \tan^{-1} \frac{2.248}{5.767} = 22.94^\circ$$

$$\Delta\gamma = \gamma_2 - \gamma_1 = 22.94^\circ - 31.13^\circ = -8.181^\circ$$

$$\Delta v = \sqrt{v_1^2 + v_2^2 - 2v_1v_2 \cos \Delta\gamma} = \sqrt{6.114^2 + 5.767^2 - 2 \cdot 6.114 \cdot 5.767 \cos(-8.181^\circ)} = 0.9155 \text{ km/s}$$

**Problem 6.17**

$$r_A = 12\,756 \text{ km} \quad v_A = 6.5992 \text{ km/s} \quad \gamma_A = 20^\circ$$

Orbit 1:

$$v_{A\perp} = v_A \cos \gamma_A = 6.5992 \cos 20^\circ = 6.20122 \text{ km/s}$$

$$\therefore h_1 = r_A v_{A\perp} = 12\,756 \cdot 6.20122 = 79\,102.8 \text{ km}^2/\text{s}$$

$$v_{Ar} = v_A \sin \gamma_A = 6.5992 \cdot \sin 20^\circ = 2.25706 \text{ km/s}$$

$$v_{Ar} = \frac{\mu}{h_1} e_1 \sin \theta_A$$

$$2.25706 = \frac{398600}{79102.8} e_1 \sin \theta_A \Rightarrow e_1 \sin \theta_A = 0.447917$$

$$r_A = \frac{h_1^2}{\mu} \frac{1}{1 + e_1 \cos \theta_A}$$

$$12756 = \frac{79102.8^2}{398600} \frac{1}{1 + e_1 \cos \theta_A} \Rightarrow e_1 \cos \theta_A = 0.230641$$

$$\therefore e_1^2 (\sin^2 \theta_A + \cos^2 \theta_A) = 0.447917^2 + 0.230641^2$$

$$e_1^2 = 0.253825 \Rightarrow e_1 = 0.50381$$

$$\therefore \sin \theta_A = \frac{0.447917}{0.50381} = 0.889058 \Rightarrow \theta_A = 62.7552^\circ \text{ or } \theta_A = 117.235^\circ$$

Since  $\cos \theta_A > 0$ ,  $\theta_A = 62.7552^\circ$ .

$$r_B = \frac{h_1^2}{\mu} \frac{1}{1 + e_1 \cos \theta_{B1}} = \frac{79102.8^2}{398600} \frac{1}{1 + 0.50381 \cos 150^\circ} = 27848.9 \text{ km}$$

$$v_{B\perp} \Big|_1 = \frac{h_1}{r_B} = \frac{79102.8}{27848.9} = 2.84043 \text{ km/s}$$

$$v_{Br} \Big|_1 = \frac{\mu}{h_1} e_1 \sin \theta_{B1} = \frac{398600}{79102.8} \cdot 0.50381 \cdot \sin 150^\circ = 1.26945 \text{ km/s}$$

Orbit 2:

$$\Delta v_{B\perp} = 0.75820 \text{ km/s}$$

$$\therefore v_{B\perp} \Big|_2 = v_{B\perp} \Big|_1 + \Delta v_{B\perp} = 2.84043 + 0.75820 = 3.59863 \text{ km/s}$$

$$h_2 = r_B v_{B\perp} \Big|_2 = 27848.9 \cdot 3.59863 = 100218 \text{ km}^2/\text{s}$$

$$\Delta v_{Br} = 0$$

$$\therefore v_{Br} \Big|_2 = v_{Br} \Big|_1 + \Delta v_{Br} = 1.26945 + 0 = 1.26945 \text{ km/s}$$

$$v_{Br} \Big|_2 = \frac{\mu}{h_2} e_2 \sin \theta_{B2}$$

$$1.26945 = \frac{398600}{100218} e_2 \sin \theta_{B2} \Rightarrow e_2 \sin \theta_{B2} = 0.319146$$

$$r_B = \frac{h_2^2}{\mu} \frac{1}{1 + e_2 \cos \theta_{B2}}$$

$$27848.9 = \frac{100218^2}{398600} \frac{1}{1 + e_2 \cos \theta_{B2}} \Rightarrow e_2 \cos \theta_{B2} = -0.0952166$$

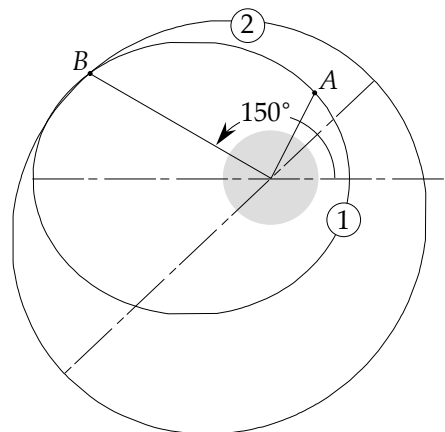

$$e_2^2 (\sin^2 \theta_{B_2} + \cos^2 \theta_{B_2}) = 0.319146^2 + (-0.0952166)^2$$

$$e_2^2 = 0.110921$$

$$e_2 = 0.333048$$

$$\therefore \sin \theta_{B_2} = \frac{0.319146}{0.333048} = 0.958261 \Rightarrow \theta_{B_2} = 73.3877^\circ \text{ or } 106.612^\circ$$

Since  $\cos \theta_{B_2} < 0$ ,  $\theta_{B_2} = 106.612^\circ$ .

$$\Delta\theta = 150 - 106.612^\circ = \underline{43.3877^\circ}$$

That is, the apse line is rotated  $43.3877^\circ$  ccw from that of orbit 1.

### Problem 6.18

$$r_1 = r_2$$

$$\frac{h^2}{\mu} \frac{1}{1 + e \cos \theta} = \frac{h^2}{\mu} \frac{1}{1 + e \cos(\eta - \theta)}$$

$$\cos \theta = \cos(\eta - \theta)$$

$$\therefore \theta = \eta - \theta \Rightarrow 2\theta = \eta \Rightarrow \underline{\theta = \frac{\eta}{2}}$$

### Problem 6.19

Orbit 1:

$$r_{P_1} = \frac{h_1^2}{\mu} \frac{1}{1 + e}$$

Orbit 2:

$$r_{P_1} = \frac{h_2^2}{\mu} \frac{1}{1 + e \cos 90^\circ} = \frac{h_2^2}{\mu}$$

$$\therefore \frac{h_2^2}{\mu} = \frac{h_1^2}{\mu} \frac{1}{1 + e} \Rightarrow \underline{h_2 = \frac{h_1}{\sqrt{1 + e}}}$$

### Problem 6.20

At A:

$$r = \frac{h^2}{\mu}$$

$$v_{r1} = \frac{\mu}{h} e \sin 90^\circ = \frac{\mu}{h} e$$

$$v_{r2} = \frac{\mu}{h} e \sin(-90^\circ) = -\frac{\mu}{h} e$$

$$v_{\perp 1} = v_{\perp 2} = \frac{h}{r}$$

$$\therefore \Delta v_{\perp} = 0$$

$$\Delta v_r = v_{r2} - v_{r1} = -2 \frac{\mu}{h} e$$

$$\therefore \Delta v = |\Delta v_r| = \frac{2\mu e}{h}$$

**Problem 6.21** For the circular orbit of the space station,

$$r = 6728 \text{ km} \quad v_c = \sqrt{\frac{\mu}{r}} = \sqrt{\frac{398\,600}{6728}} = 7.697 \text{ km/s} \quad T_c = \frac{2\pi}{\sqrt{\mu}} r^{3/2} = \frac{2\pi}{\sqrt{398\,600}} 6728^{3/2} = 5492 \text{ s} = 91.54 \text{ m}$$

(a) The time required for spacecraft *A* to reach the space station is the time it takes for the space station to fly around to the original position of spacecraft *A*.

$$t_{SA} = T_c \frac{2\pi r - 600}{2\pi r} = 5492 \frac{2\pi \cdot 6728 - 600}{2\pi \cdot 6728} = 5414 \text{ s} = \underline{90.2 \text{ min}}$$

The time required for spacecraft *B* to reach the space station is the time it takes for the space station to fly around to the original position of spacecraft *B*.

$$t_{BS} = T_c \frac{2\pi r + 600}{2\pi r} = 5492 \frac{2\pi \cdot 6728 + 600}{2\pi \cdot 6728} = 5570 \text{ s} = \underline{92.8 \text{ min}}$$

(b)

The period of spacecraft *A*'s phasing orbit, is  $t_{SA}$ , which determines the semimajor axis of that orbit:

$$5414 = \frac{2\pi}{\sqrt{398\,600}} a_A^{3/2} \Rightarrow a_A = 6664 \text{ km}$$

Spacecraft *A* is at the *apogee* of its phasing orbit. From the energy equation

$$v_A = \sqrt{\mu \left( \frac{2}{r} - \frac{1}{a_A} \right)} = \sqrt{398\,600 \left( \frac{2}{6728} - \frac{1}{6664} \right)} = 7.660 \text{ km/s}$$

The delta- $v$  required to drop into the phasing orbit is

$$\Delta v_A = v_A - v_c = 7.660 - 7.697 = -0.03694 \text{ km/s}$$

Spacecraft *A* must therefore slow down in order to speed up (i.e., catch the space station). After one circuit of its phasing orbit, this delta- $v$  must be *added* in order to rejoin the circular orbit. Thus

$$\Delta v_{A\text{total}} = 2|\Delta v_A| = \underline{0.07388 \text{ km/s}}$$

The period of spacecraft *B*'s phasing orbit, is  $t_{BS}$ , which determines the semimajor axis of that orbit:

$$5570 = \frac{2\pi}{\sqrt{398\,600}} a_B^{3/2} \Rightarrow a_B = 6791 \text{ km}$$

Spacecraft *B* is at the *perigee* of its phasing orbit. From the energy equation

$$v_B = \sqrt{\mu \left( \frac{2}{r} - \frac{1}{a_B} \right)} = \sqrt{398\,600 \left( \frac{2}{6728} - \frac{1}{6791} \right)} = 7.733 \text{ km/s}$$

The prograde delta- $v$  required to enter the phasing orbit is

$$\Delta v_B = v_B - v_c = 7.733 - 7.697 = +0.03576 \text{ km/s}$$

Spacecraft  $B$  must therefore speed up in order to slow down (i.e, allow the space station to catch up). After one circuit of its phasing orbit, this delta- $v$  must be *subtracted* in order to rejoin the circular orbit. Thus

$$\Delta v_{B_{total}} = 2|\Delta v_B| = \underline{0.07153 \text{ km/s}}$$

### Problem 6.22

$$\begin{aligned} T_{\text{phasing}} &= \frac{T}{2} \\ \frac{2\pi}{\sqrt{\mu}} a^{3/2} &= \frac{1}{2} \frac{2\pi}{\sqrt{\mu}} r^{3/2} \\ a^{3/2} &= \frac{1}{2} r^{3/2} \\ a &= \left( \frac{1}{2} r^{3/2} \right)^{2/3} \Rightarrow \underline{a = 0.63r} \end{aligned}$$

### Problem 6.23

$$r_A = 13000 \text{ km} \quad r_P = 8000 \text{ km}$$

Orbit 1:

$$\begin{aligned} a_1 &= \frac{r_A + r_P}{2} = 10500 \text{ km} \\ e_1 &= \frac{r_A - r_P}{r_A + r_P} = 0.2381 \\ h_1 &= \sqrt{\mu(1+e)r_P} = \sqrt{398600(1+0.2381) \cdot 8000} = 62830 \text{ km}^2/\text{s} \\ T_1 &= \frac{2\pi}{\sqrt{\mu}} a^{3/2} = \frac{2\pi}{\sqrt{398600}} 10500^{3/2} = 10710 \text{ s} \end{aligned}$$

Time of flight from  $P$  to  $C$ :

$$\begin{aligned} E_C &= \tan^{-1} \left( \sqrt{\frac{1-e_1}{1+e_1}} \tan \frac{\theta_C}{2} \right) = \tan^{-1} \left( \sqrt{\frac{1-0.2381}{1+0.2381}} \tan \frac{30^\circ}{2} \right) = 0.4144 \text{ rad} \\ M_C &= E_C - e_1 \sin E_C = 0.4144 - 0.2381 \sin 0.4144 = 0.3185 \text{ rad} \\ t_C &= \frac{M_C}{2\pi} T = \frac{0.3185}{2\pi} \cdot 10710 = 542.8 \text{ s} \end{aligned}$$

Time of flight from  $P$  to  $D$ :

$$\begin{aligned} E_D &= \tan^{-1} \left( \sqrt{\frac{1-e_1}{1+e_1}} \tan \frac{\theta_D}{2} \right) = \tan^{-1} \left( \sqrt{\frac{1-0.2381}{1+0.2381}} \tan \frac{90^\circ}{2} \right) = 1.330 \text{ rad} \\ M_D &= E_D - e_1 \sin E_D = 1.330 - 0.2381 \sin 1.330 = 1.099 \text{ rad} \\ t_D &= \frac{M_D}{2\pi} T = \frac{1.099}{2\pi} \cdot 10710 = 1873 \text{ s} \end{aligned}$$

Time of flight from  $C$  to  $D$ :

$$t_{CD} = t_D - t_C = 1873 - 542.8 = 1330 \text{ s}$$

To determine the trajectory from  $P$  to  $D$  is Lambert's problem. Note that

$$r_D = \frac{h_1^2}{\mu} \frac{1}{1+e_1 \cos \theta_D} = \frac{62830^2}{398600} \frac{1}{1+0.2381 \cos 90^\circ} = 9905 \text{ km}$$

so that in perifocal coordinates

$$\mathbf{r}_P = 8000\hat{\mathbf{p}} \text{ km} \quad \mathbf{r}_D = 9905\hat{\mathbf{q}} \text{ km}$$

Note as well, that on orbit 1,

$$\begin{aligned} \mathbf{v}_{P1} &= \frac{\mu}{h_1} [-\sin\theta_P\hat{\mathbf{p}} + (e + \cos\theta_P)\hat{\mathbf{q}}] = \frac{398600}{62830} [-\sin 0\hat{\mathbf{p}} + (0.2381 + \cos 0)\hat{\mathbf{q}}] \\ &= 7.854\hat{\mathbf{q}} \text{ (km/s)} \end{aligned}$$

$$\begin{aligned} \mathbf{v}_{D1} &= \frac{\mu}{h_1} [-\sin\theta_D\hat{\mathbf{p}} + (e + \cos\theta_D)\hat{\mathbf{q}}] = \frac{398600}{62830} [-\sin 90^\circ\hat{\mathbf{p}} + (0.2381 + \cos 90^\circ)\hat{\mathbf{q}}] \\ &= -6.344\hat{\mathbf{p}} + 1.510\hat{\mathbf{q}} \text{ (km/s)} \end{aligned}$$

The following MATLAB script calls upon Algorithm 5.2, implemented as the M-function `lambert` in Appendix D.11, to solve Lambert's problem for the velocities on orbit 2 at  $P$  and  $D$ . The output to the MATLAB Command Window is listed afterwards.

```
%
% ~~~~~
% Problem 6_23
% ~~~~~
%
% This program uses Algorithm 5.2 to solve Lambert's problem for the
% data of in Problem 6.23.
%
% deg      - factor for converting between degrees and radians
% pi       - 3.1415926...
% mu       - gravitational parameter (km^3/s^2)
% r1, r2   - initial and final radii (km)
% dt       - time between r1 and r2 (s)
% dtheta   - change in true anomaly during dt (degrees)
% R1, R2   - initial and final position vectors (km)
% string   - = 'pro' if the orbit is prograde
%           - = 'retro' if the orbit is retrograde
% V1, V2   - initial and final velocity vectors (km/s)
%
% User M-function required: lambert
% -----
clear
global mu
mu      = 398600;          %km^3/s^2
deg     = pi/180;

r1      = 8000;          %km
r2      = 9905;          %km
dt      = 1330;          %sec
dtheta  = 90;            %degrees

R1 = [r1 0 0];
R2 = [r2*cos(dtheta*deg) r2*sin(dtheta*deg) 0];

%...Algorithm 5.2:
string = 'pro';
[V1 V2] = lambert(R1, R2, dt, string);

%...Echo the input data and output results to the command window:
fprintf('\n-----\n')
fprintf('\n Problem 6.23: Lambert''s Problem\n')

fprintf('\n Input data:\n');
```



```

fprintf('\n   Gravitational parameter (km^3/s^2) = %g\n', mu)
fprintf('\n   Radius 1 (km)                        = %g', r1)
fprintf('\n   Position vector R1 (km)                = [%g %g %g]\n',...
                                               R1(1), R1(2), R1(3))
fprintf('\n   Radius 2 (km)                        = %g', r2)
fprintf('\n   Position vector R2 (km)                = [%g %g %g]\n',...
                                               R2(1), R2(2), R2(3))
fprintf('\n   Elapsed time (s)                      = %g', dt)
fprintf('\n   Change in true anomaly (deg) = %g', dtheta)

fprintf('\n\n Solution:\n')
fprintf('\n   Velocity vector V1 (km/s) = [%g %g %g]',...
                                               V1(1), V1(2), V1(3))
fprintf('\n   Velocity vector V2 (km/s) = [%g %g %g]',...
                                               V2(1), V2(2), V2(3))
fprintf('\n-----\n')

```

---

### Problem 6.23: Lambert's Problem

Input data:

```

Gravitational parameter (km^3/s^2) = 398600

Radius 1 (km)                        = 8000
Position vector R1 (km)              = [8000  0  0]

Radius 2 (km)                        = 9905
Position vector R2 (km)              = [-0  9905  0]

Elapsed time (s)                     = 1330
Change in true anomaly (deg) = 90

```

Solution:

```

Velocity vector V1 (km/s) = [-2.53168  9.57638  0]
Velocity vector V2 (km/s) = [-7.73458  4.37347  0]

```

$$\mathbf{v}_{P2} = -2.532\hat{\mathbf{p}} + 9.576\hat{\mathbf{q}} \text{ (km/s)}$$

$$\mathbf{v}_{D2} = -7.734\hat{\mathbf{p}} + 4.373\hat{\mathbf{q}} \text{ (km/s)}$$

$$\Delta\mathbf{v}_P = \mathbf{v}_{P2} - \mathbf{v}_{P1} = (-2.532\hat{\mathbf{p}} + 9.576\hat{\mathbf{q}}) - 7.854\hat{\mathbf{q}} = -2.532\hat{\mathbf{p}} + 1.722\hat{\mathbf{q}} \text{ (km/s)}$$

$$\|\Delta\mathbf{v}_P\| = \sqrt{(-2.532)^2 + 1.722^2} = 3.062 \text{ (km/s)}$$

$$\Delta\mathbf{v}_D = \mathbf{v}_{D2} - \mathbf{v}_{D1} = (-7.734\hat{\mathbf{p}} + 4.373\hat{\mathbf{q}}) - (-6.344\hat{\mathbf{p}} + 1.510\hat{\mathbf{q}}) = -1.391\hat{\mathbf{p}} + 2.863\hat{\mathbf{q}} \text{ (km/s)}$$

$$\|\Delta\mathbf{v}_D\| = \sqrt{(-1.391)^2 + 2.863^2} = 3.183 \text{ (km/s)}$$

$$\Delta v_{total} = \|\Delta\mathbf{v}_P\| + \|\Delta\mathbf{v}_D\| = 3.062 + 3.183 = \underline{6.245 \text{ km/s}}$$

---

### Problem 6.24

$$h = \sqrt{\mu a(1 - e^2)} = \sqrt{398600 \cdot 15000 \cdot (1 - 0.5^2)} = 66960 \text{ km}^2/\text{s}$$

$$r_{\text{ascending node}} = \frac{h^2}{\mu} \frac{1}{1 + e \cos(-\omega)} = \frac{66960^2}{398600} \frac{1}{1 + 0.5 \cos(-30^\circ)} = 7851 \text{ km}$$

$$r_{\text{descending node}} = \frac{h^2}{\mu} \frac{1}{1 + e \cos(-\omega + \pi)} = \frac{66\,960^2}{398\,600} \frac{1}{1 + 0.5 \cos(-30^\circ + 180^\circ)} = 19\,840 \text{ km}$$

Rotate the orbital plane 10 degrees around the node line. That means hold  $v_r$  fixed and rotate  $v_\perp$  10 degrees. For minimum delta-v, do this maneuver at the furthest distance from the focus (at the descending node, rather than the ascending node).

$$v_\perp = \frac{h}{r_{\text{descending node}}} = \frac{66\,960}{19\,840} = 3.375 \text{ km/s}$$

$$\Delta v = 2v_\perp \sin \frac{\Delta i}{2} = 2 \cdot 3.375 \cdot \sin \frac{10^\circ}{2} = \underline{0.5883 \text{ km/s}}$$

(Note: if the maneuver is done at the ascending node,

$$v_\perp = \frac{h}{r_{\text{ascending node}}} = \frac{66\,960}{7851} = 8.53 \text{ km/s}$$

$$\Delta v = 2v_\perp \sin \frac{\Delta i}{2} = 2 \cdot 8.53 \cdot \sin \frac{10^\circ}{2} = 1.487 \text{ km/s}$$

Over twice the delta-v requirement.)

**Problem 6.25** For the circular orbit

$$v_1 = \sqrt{\frac{\mu}{r}} = \sqrt{\frac{398\,600}{6778}} = 7.668 \text{ km/s}$$

Assume the maneuver is done at apogee of the ellipse (orbit 2).

$$r = \frac{h_2^2}{\mu} \frac{1}{1 - e_2}$$

$$6778 = \frac{h_2^2}{398\,600} \frac{1}{1 - 0.5} \Rightarrow h_2 = 36750 \text{ km}^2/\text{s}$$

Then

$$r_{\text{perigee}} = \frac{h_2^2}{\mu} \frac{1}{1 + e_2} = \frac{36750^2}{398\,600} \frac{1}{1 + 0.5} = 2259 \text{ km}$$

which is inside the earth. So the maneuver cannot occur at apogee. Assume it occurs at perigee.

$$r = \frac{h_2^2}{\mu} \frac{1}{1 + e_2}$$

$$6778 = \frac{h_2^2}{398\,600} \frac{1}{1 + 0.5} \Rightarrow h_2 = 63\,660 \text{ km}^2/\text{s}$$

$$v_2 = \frac{h_2}{r} = \frac{63\,660}{6778} = 9.392 \text{ km/s}$$

$$\Delta v = \sqrt{v_1^2 + v_2^2 - 2v_1v_2 \cos \delta} = \sqrt{7.668^2 + 9.392^2 - 2 \cdot 7.668 \cdot 9.392 \cos \delta} = \underline{3.414 \text{ km/s}}$$

**Problem 6.26**

$$r_{\text{apogee}} = \frac{h^2}{\mu} \frac{1}{1-e} = \frac{60\,000^2}{398\,600} \frac{1}{1-0.3} = 12\,900 \text{ km}$$

$$v_{\text{apogee}} = \frac{h}{r_{\text{apogee}}} = \frac{60\,000}{12\,900} = 4.65 \text{ km/s}$$

$$\Delta v = 2v_{\text{apogee}} \sin \frac{\delta}{2} = 2 \cdot 4.65 \sin \frac{90^\circ}{2} = \underline{6.577 \text{ km/s}}$$

**Problem 6.27**

$$v_{B1} = \sqrt{\frac{\mu}{r_o}}$$

$$r_o = \frac{h_2^2}{\mu} \frac{1}{1+e \cos \theta} = \frac{h_2^2}{\mu} \frac{1}{1+0.25 \cos(-90^\circ)} = \frac{h_2^2}{\mu} \Rightarrow h_2 = \sqrt{\mu r_o}$$

$$v_{B\perp 2} = \frac{h_2}{r_o} = \frac{\sqrt{\mu r_o}}{r_o} = \sqrt{\frac{\mu}{r_o}}$$

$$v_{Br2} = \frac{\mu}{h_2} e_2 \sin \theta = \frac{\mu}{\sqrt{\mu r_o}} \cdot 0.25 \cdot \sin(-90^\circ) = -0.25 \sqrt{\frac{\mu}{r_o}}$$

$$\Delta v = \sqrt{(v_{Br2} - v_{Br1})^2 + v_{B\perp 1}^2 + v_{B\perp 2}^2 - 2v_{B\perp 1}v_{B\perp 2} \cos \delta}$$

$$\Delta v = \sqrt{\left(-0.25 \sqrt{\frac{\mu}{r_o}} - 0\right)^2 + \sqrt{\frac{\mu}{r_o}}^2 + \sqrt{\frac{\mu}{r_o}}^2 - 2\sqrt{\frac{\mu}{r_o}}\sqrt{\frac{\mu}{r_o}} \cos(-90^\circ)}$$

$$\Delta v = \sqrt{0.0625 \frac{\mu}{r_o} + \frac{\mu}{r_o} + \frac{\mu}{r_o} - 0}$$

$$\Delta v = \sqrt{2.0625 \frac{\mu}{r_o}}$$

$$\Delta v = 1.436 \sqrt{\frac{\mu}{r_o}}$$

**Problem 6.28** The initial and target orbits are “1” and “2”, respectively, and “3” is the transfer orbit.

$$r_1 = 6678 \text{ km}$$

$$v_1 = \sqrt{\frac{\mu}{r_1}} = \sqrt{\frac{398\,600}{6678}} = 7.726 \text{ km/s}$$

$$r_2 = 6978 \text{ km}$$

$$v_2 = \sqrt{\frac{\mu}{r_2}} = \sqrt{\frac{398\,600}{6978}} = 7.558 \text{ km/s}$$

$$a_3 = \frac{r_1 + r_2}{2} = \frac{6678 + 6978}{2} = 6828 \text{ km}$$

$$v_{\text{perigee}3} = \sqrt{\mu \left( \frac{2}{r_1} - \frac{1}{a_3} \right)} = \sqrt{398\,600 \left( \frac{2}{6678} - \frac{1}{6828} \right)} = 7.810 \text{ km/s}$$

$$v_{\text{apogee}3} = \sqrt{\mu \left( \frac{2}{r_2} - \frac{1}{a_3} \right)} = \sqrt{398\,600 \left( \frac{2}{6978} - \frac{1}{6828} \right)} = 7.474 \text{ km/s}$$

(a)

$$\begin{aligned}\Delta v &= (v_{\text{perigee}_3} - v_1) + (v_2 - v_{\text{apogee}_3}) + 2 \cdot v_2 \sin \frac{\Delta i}{2} \\ &= (7.810 - 7.726) + (7.558 - 7.474) + 2 \cdot 7.558 \sin \frac{20^\circ}{2} \\ &= 0.0844 + 0.08348 + 2.625 = \underline{2.793 \text{ km/s}}\end{aligned}$$

(b)

$$\begin{aligned}\Delta v &= (v_{\text{perigee}_3} - v_1) + \sqrt{v_{\text{apogee}_3}^2 + v_2^2 - 2v_{\text{apogee}_3}v_2 \cos \Delta i} \\ &= (7.810 - 7.726) + \sqrt{7.474^2 + 7.588^2 - 2 \cdot 7.474 \cdot 7.588 \cos 20^\circ} \\ &= 0.0844 + 2.612 = \underline{2.696 \text{ km/s}}\end{aligned}$$

(c)

$$\begin{aligned}\Delta v &= \sqrt{v_{\text{perigee}_3}^2 + v_1^2 - 2v_{\text{perigee}_3}v_1 \cos \Delta i} + (v_2 - v_{\text{apogee}_3}) \\ &= \sqrt{7.81^2 + 7.726^2 - 2 \cdot 7.81 \cdot 7.726 \cos 20^\circ} + (7.558 - 7.474) \\ &= 2.699 + 0.08348 = \underline{2.783 \text{ km/s}}\end{aligned}$$

**Problem 6.29** Design problem.**Problem 6.30**

$$A = \sin^{-1} \left( \frac{\cos i}{\cos \phi} \right)$$

$$(a) \quad A = \sin^{-1} \left( \frac{\cos 116.57^\circ}{\cos 28.5^\circ} \right) = \sin^{-1}(-0.5088) = \underline{329.4^\circ}$$

$$(b) \quad A = \sin^{-1} \left( \frac{\cos 116.57^\circ}{\cos 34.5^\circ} \right) = \sin^{-1}(-0.5427) = \underline{327.1^\circ}$$

$$(c) \quad A = \sin^{-1} \left( \frac{\cos 116.57^\circ}{\cos 34.5^\circ} \right) = \sin^{-1}(-0.4493) = \underline{333.3^\circ}$$

**Problem 7.1**

$$\hat{\mathbf{i}} = 0\hat{\mathbf{I}} + \hat{\mathbf{j}} + 0\hat{\mathbf{K}}$$

$$\hat{\mathbf{j}} = 0\hat{\mathbf{I}} + 0\hat{\mathbf{J}} + \hat{\mathbf{K}}$$

$$\hat{\mathbf{k}} = \hat{\mathbf{I}} + 0\hat{\mathbf{J}} + 0\hat{\mathbf{K}}$$

$$\therefore [\mathbf{Q}]_{Xx} = \begin{bmatrix} 0 & 1 & 0 \\ 0 & 0 & 1 \\ 1 & 0 & 0 \end{bmatrix}$$

$$\mathbf{r}_B = (6378 + 250)\hat{\mathbf{K}} = 6628\hat{\mathbf{K}} \text{ ( km)}$$

$$\mathbf{v}_B = -\sqrt{\frac{\mu}{r_B}}\hat{\mathbf{j}} = -\sqrt{\frac{398\,600}{6628}}\hat{\mathbf{j}} = -7.754\,92\hat{\mathbf{j}} \text{ (km/s)}$$

$$\mathbf{a}_B = -\frac{v_B^2}{r_B}\hat{\mathbf{K}} = -\frac{7.755^2}{6628}\hat{\mathbf{K}} = -0.009\,073\,45\hat{\mathbf{K}} \text{ (km}^2\text{/s)}$$

$$\mathbf{r}_A = (6378 + 300)\hat{\mathbf{K}} = 6678\hat{\mathbf{J}} \text{ ( km)}$$

$$\mathbf{v}_A = \sqrt{\frac{\mu}{r_A}}\hat{\mathbf{K}} = \sqrt{\frac{398\,600}{6678}}\hat{\mathbf{K}} = 7.725\,84\hat{\mathbf{K}} \text{ (km/s)}$$

$$\mathbf{a}_A = -\frac{v_A^2}{r_A}\hat{\mathbf{j}} = -\frac{7.755^2}{6628}\hat{\mathbf{j}} = -0.008\,938\,08\hat{\mathbf{j}} \text{ (km}^2\text{/s)}$$

$$\boldsymbol{\Omega}_{xyz} = \frac{v_A}{r_A}\hat{\mathbf{i}} = \frac{7.726}{6678}\hat{\mathbf{i}} = 0.001\,156\,91\hat{\mathbf{i}} \text{ (rad/s)}$$

$$\dot{\boldsymbol{\Omega}}_{xyz} = 0$$

$$\mathbf{r}_{rel} = \mathbf{r}_B - \mathbf{r}_A = -6678\hat{\mathbf{J}} + 6628\hat{\mathbf{K}} \text{ ( km)}$$

$$\{\mathbf{r}_{rel}\}_{xyz} = [\mathbf{Q}]_{Xx} \{\mathbf{r}_{rel}\}_{XYZ} = \begin{bmatrix} 0 & 1 & 0 \\ 0 & 0 & 1 \\ 1 & 0 & 0 \end{bmatrix} \begin{bmatrix} 0 \\ -6678 \\ 6628 \end{bmatrix} = \begin{bmatrix} -6678 \\ 6628 \\ 0 \end{bmatrix}$$

$$\mathbf{r}_{rel} = -6678\hat{\mathbf{i}} + 6628\hat{\mathbf{j}} \text{ ( km)}$$

$$\mathbf{v}_B = \mathbf{v}_A + \boldsymbol{\Omega}_{xyz} \times \mathbf{r}_{rel} + \mathbf{v}_{rel}$$

$$-7.754\,92\hat{\mathbf{j}} = 7.725\,84\hat{\mathbf{K}} + (0.001\,156\,91\hat{\mathbf{i}}) \times (-6678\hat{\mathbf{J}} + 6628\hat{\mathbf{K}}) + \mathbf{v}_{rel}$$

$$-7.754\,92\hat{\mathbf{j}} = 7.725\,84\hat{\mathbf{K}} + (-7.667\,99\hat{\mathbf{j}} - 7.725\,84\hat{\mathbf{K}}) + \mathbf{v}_{rel}$$

$$\mathbf{v}_{rel} = -0.086\,931\,6\hat{\mathbf{j}} \text{ (km/s)}$$

$$\{\mathbf{v}_{rel}\}_{xyz} = [\mathbf{Q}]_{Xx} \{\mathbf{v}_{rel}\}_{XYZ} = \begin{bmatrix} 0 & 1 & 0 \\ 0 & 0 & 1 \\ 1 & 0 & 0 \end{bmatrix} \begin{bmatrix} 0 \\ -0.086\,931\,6 \\ 0 \end{bmatrix} = \begin{bmatrix} -0.086\,931\,6 \\ 0 \\ 0 \end{bmatrix}$$

$$\mathbf{v}_{rel} = -0.086\,931\,6\hat{\mathbf{i}} \text{ (km/s)}$$

$$\mathbf{a}_B = \mathbf{a}_A + \dot{\boldsymbol{\Omega}}_{xyz} \times \mathbf{r}_{rel} + \boldsymbol{\Omega}_{xyz} \times (\boldsymbol{\Omega}_{xyz} \times \mathbf{r}_{rel}) + 2\boldsymbol{\Omega}_{xyz} \times \mathbf{v}_{rel} + \mathbf{a}_{rel}$$

$$\begin{aligned} -0.009\,073\,45\hat{\mathbf{K}} &= -0.008\,983\,08\hat{\mathbf{j}} + 0 + (0.001\,156\,91\hat{\mathbf{i}}) \times [(0.001\,156\,91\hat{\mathbf{i}}) \times (-6678\hat{\mathbf{J}} + 6628\hat{\mathbf{K}})] \\ &\quad + 2[(0.001\,156\,91\hat{\mathbf{i}}) \times (-0.086\,931\,6\hat{\mathbf{j}})] + \mathbf{a}_{rel} \end{aligned}$$

$$-0.009\,073\,45\hat{\mathbf{K}} = -8.938\,08(10^{-3})\hat{\mathbf{j}} + 0 + [1.156\,91(10^{-3})\hat{\mathbf{i}}] \times (-7.667\,99\hat{\mathbf{j}} - 7.725\,84\hat{\mathbf{K}}) \\ + 2[-0.000\,100\,572\hat{\mathbf{K}}] + \mathbf{a}_{rel}$$

$$-0.009\,073\,45\hat{\mathbf{K}} = -8.938\,08(10^{-3})\hat{\mathbf{j}} + 0 + (0.008\,938\,08\hat{\mathbf{j}} - 0.008\,871\,16\hat{\mathbf{K}}) \\ + 2(-0.000\,100\,572\hat{\mathbf{K}}) + \mathbf{a}_{rel}$$

$$-0.009\,073\,45\hat{\mathbf{K}} = -0.009\,072\,31\hat{\mathbf{K}} + \mathbf{a}_{rel}$$

$$\mathbf{a}_{rel} = -1.140\,18 \times 10^{-6} \hat{\mathbf{K}} \text{ (km/s}^2\text{)}$$

$$\{\mathbf{a}_{rel}\}_{xyz} = [\mathbf{Q}]_{Xx} \{\mathbf{a}_{rel}\}_{XYZ} = \begin{bmatrix} 0 & 1 & 0 \\ 0 & 0 & 1 \\ 1 & 0 & 0 \end{bmatrix} \begin{Bmatrix} 0 \\ 0 \\ -1.140\,18 \times 10^{-6} \end{Bmatrix} = \begin{Bmatrix} 0 \\ -1.140\,18 \times 10^{-6} \\ 0 \end{Bmatrix}$$

$$\mathbf{a}_{rel} = -1.140\,18 \times 10^{-6} \hat{\mathbf{j}} \text{ (km/s}^2\text{)}$$

**Problem 7.2**

$$\mathbf{v}_A = \sqrt{\frac{\mu}{r_A}} \hat{\mathbf{j}} = -\sqrt{\frac{398\,600}{8000}} \hat{\mathbf{j}} = 7.058\,68 \hat{\mathbf{j}} \text{ (km/s)}$$

$$\mathbf{v}_B = \sqrt{\frac{\mu}{r_B}} \hat{\mathbf{j}} = -\sqrt{\frac{398\,600}{7000}} \hat{\mathbf{j}} = 7.546\,05 \hat{\mathbf{j}} \text{ (km/s)}$$

$$\boldsymbol{\Omega}_{xyz} = \frac{v_A}{r_A} \hat{\mathbf{k}} = \frac{7.058\,68}{8000} \hat{\mathbf{k}} = 0.000\,882\,335 \hat{\mathbf{k}} \text{ (rad/s)}$$

$$\dot{\boldsymbol{\Omega}}_{xyz} = 0$$

$$\mathbf{r}_{rel} = \mathbf{r}_B - \mathbf{r}_A = -1000 \hat{\mathbf{i}} \text{ (km)}$$

$$\mathbf{v}_B = \mathbf{v}_A + \boldsymbol{\Omega}_{xyz} \times \mathbf{r}_{rel} + \mathbf{v}_{rel}$$

$$7.546\,05 \hat{\mathbf{j}} = 7.058\,68 \hat{\mathbf{j}} + (0.000\,882\,335 \hat{\mathbf{k}}) \times (-1000 \hat{\mathbf{i}}) + \mathbf{v}_{rel}$$

$$7.546\,05 \hat{\mathbf{j}} = 7.058\,68 \hat{\mathbf{j}} - 0.882\,335 \hat{\mathbf{j}} + \mathbf{v}_{rel}$$

$$\mathbf{v}_{rel} = 1.369\,70 \hat{\mathbf{j}} \text{ (km/s)}$$

$$\mathbf{a}_A = -\frac{v_A^2}{r_A} \hat{\mathbf{i}} = -\frac{7.058\,68^2}{8000} \hat{\mathbf{i}} = -0.006\,228\,12 \hat{\mathbf{i}} \text{ (km/s}^2\text{)}$$

$$\mathbf{a}_B = -\frac{v_B^2}{r_B} \hat{\mathbf{i}} = -\frac{7.546\,05^2}{7000} \hat{\mathbf{i}} = -0.008\,134\,69 \hat{\mathbf{i}} \text{ (km/s}^2\text{)}$$

$$\mathbf{a}_B = \mathbf{a}_A + \dot{\boldsymbol{\Omega}}_{xyz} \times \mathbf{r}_{rel} + \boldsymbol{\Omega}_{xyz} \times (\boldsymbol{\Omega}_{xyz} \times \mathbf{r}_{rel}) + 2\boldsymbol{\Omega}_{xyz} \times \mathbf{v}_{rel} + \mathbf{a}_{rel}$$

$$-0.008\,134\,69 \hat{\mathbf{i}} = -0.006\,228\,12 \hat{\mathbf{i}} + 0 + (0.000\,882\,335 \hat{\mathbf{k}}) \times [(0.000\,882\,335 \hat{\mathbf{k}}) \times (-1000 \hat{\mathbf{i}})] \\ + 2(0.000\,882\,335 \hat{\mathbf{k}}) \times (1.369\,70 \hat{\mathbf{j}}) + \mathbf{a}_{rel}$$

$$-0.008\,134\,69\hat{\mathbf{i}} = -0.006\,228\,12\hat{\mathbf{i}} + (0.000\,882\,335\hat{\mathbf{k}}) \times (-0.882\,335\hat{\mathbf{j}}) \\ + 2(-0.001\,208\,54\hat{\mathbf{i}}) + \mathbf{a}_{rel}$$

$$0.008\,134\,69\hat{\mathbf{i}} = -0.006\,228\,12\hat{\mathbf{i}} + 0.000\,778\,516\hat{\mathbf{k}} \\ - 0.002\,417\,07\hat{\mathbf{i}} + \mathbf{a}_{rel}$$

$$-0.008\,134\,69\hat{\mathbf{i}} = -0.007\,866\,68\hat{\mathbf{i}} + \mathbf{a}_{rel} \\ \mathbf{a}_{rel} = \underline{-0.000\,268\,012\hat{\mathbf{i}} \text{ (km/s}^2\text{)}}$$

**Problem 7.3**  $\mathbf{r} = \mathbf{r}_o + \delta\mathbf{r}$ 

(a)

$$r = [(\mathbf{r}_o + \delta\mathbf{r}) \cdot (\mathbf{r}_o + \delta\mathbf{r})]^{1/2} \\ = (\mathbf{r}_o \cdot \mathbf{r}_o + 2\mathbf{r}_o \cdot \delta\mathbf{r} + \delta\mathbf{r} \cdot \delta\mathbf{r})^{1/2} \\ = (r_o^2 + 2\mathbf{r}_o \cdot \delta\mathbf{r} + \delta r^2)^{1/2} \\ = r_o \left[ 1 + \frac{2\mathbf{r}_o \cdot \delta\mathbf{r}}{r_o^2} + \left( \frac{\delta r}{r_o} \right)^2 \right]^{1/2}$$

Keep only terms of the first order in  $\delta r$ :

$$r = r_o \left( 1 + \frac{2\mathbf{r}_o \cdot \delta\mathbf{r}}{r_o^2} \right)^{1/2} \\ \therefore \sqrt{r} = \sqrt{r_o} \left( 1 + \frac{2\mathbf{r}_o \cdot \delta\mathbf{r}}{r_o^2} \right)^{1/4}$$

By means of the binomial theorem,

$$\sqrt{r} = \sqrt{r_o} \left( 1 + \frac{1}{4} \frac{2\mathbf{r}_o \cdot \delta\mathbf{r}}{r_o^2} \right) = \sqrt{r_o} + \frac{1}{2} \frac{\mathbf{r}_o \cdot \delta\mathbf{r}}{r_o^{3/2}} \\ \therefore O(\delta\mathbf{r}) = \underline{\frac{1}{2} \frac{\mathbf{r}_o \cdot \delta\mathbf{r}}{r_o^{3/2}}}$$

(b)

$$\mathbf{r}_o = 3\hat{\mathbf{i}} + 4\hat{\mathbf{j}} + 5\hat{\mathbf{k}} \quad \delta\mathbf{r} = 0.01\hat{\mathbf{i}} - 0.01\hat{\mathbf{j}} + 0.03\hat{\mathbf{k}} \quad (\delta r = 0.033\,166\,2)$$

$$r_o = (3^2 + 4^2 + 5^2)^{1/2} = 7.071\,07$$

$$\sqrt{r_o} = 2.659\,15$$

$$O(\delta\mathbf{r}) = \frac{1}{2} \frac{\mathbf{r}_o \cdot \delta\mathbf{r}}{r_o^{3/2}} = \frac{1}{2} \frac{(3\hat{\mathbf{i}} + 4\hat{\mathbf{j}} + 5\hat{\mathbf{k}}) \cdot (0.01\hat{\mathbf{i}} - 0.01\hat{\mathbf{j}} + 0.03\hat{\mathbf{k}})}{7.071\,07^{3/2}} = \frac{1}{2} \frac{0.140\,000}{18.803\,00} = 0.003\,722\,81$$

$$\mathbf{r} = 3.01\hat{\mathbf{i}} + 3.99\hat{\mathbf{j}} + 5.03\hat{\mathbf{k}}$$

$$r = (3.01^2 + 3.99^2 + 5.03^2)^{1/2} = 7.090\,92$$

$$\sqrt{r} = 2.662\,88$$

$$\sqrt{r} - \sqrt{r_o} = 0.003\,729\,58$$

$$\left| \frac{(\sqrt{r} - \sqrt{r_0}) - O(\delta\mathbf{r})}{\sqrt{r} - \sqrt{r_0}} \right| \cdot 100 = \left| \frac{0.003\,729\,58 - 0.003\,722\,81}{0.003\,729\,58} \right| \cdot 100 = \underline{0.181\,565\%}$$

Thus,  $O(\delta\mathbf{r})$  is within 0.2% of  $\sqrt{r} - \sqrt{r_0}$ ,

$$(c) \delta\mathbf{r} = \hat{\mathbf{i}} - \hat{\mathbf{j}} + 3\hat{\mathbf{k}} \quad (\delta r = 3.316\,62, \delta r/r_0 = 4.69 \times 10^{-1})$$

$$O(\delta\mathbf{r}) = \frac{1}{2} \frac{\mathbf{r}_0 \cdot \delta\mathbf{r}}{r_0^{3/2}} = \frac{1}{2} \frac{(3\hat{\mathbf{i}} + 4\hat{\mathbf{j}} + 5\hat{\mathbf{k}}) \cdot (\hat{\mathbf{i}} - \hat{\mathbf{j}} + 3\hat{\mathbf{k}})}{7.071\,07^{3/2}} = \frac{1}{2} \frac{14}{18.80300} = 0.372\,281$$

$$\mathbf{r} = \mathbf{r}_0 + \delta\mathbf{r} = 4\hat{\mathbf{i}} + 3\hat{\mathbf{j}} + 8\hat{\mathbf{k}}$$

$$r = (4^2 + 3^2 + 8^2)^{1/2} = 9.433\,98$$

$$\sqrt{r} = 3.071\,48$$

$$\sqrt{r} - \sqrt{r_0} = 0.412\,331$$

$$\left| \frac{(\sqrt{r} - \sqrt{r_0}) - O(\delta\mathbf{r})}{\sqrt{r} - \sqrt{r_0}} \right| \cdot 100 = \left| \frac{0.412\,331 - 0.372\,281}{0.412\,331} \right| \cdot 100 = \underline{9.713\,08\%}$$

In this case  $O(\delta\mathbf{r})$  is a poor approximation, exceeding  $\sqrt{r} - \sqrt{r_0}$  by almost 10 percent.

**Problem 7.4** For  $e \ll 1$ :

$$\begin{aligned} r &= \frac{a(1 - e^2)}{1 + e \cos \theta} \\ &\approx a(1 - e^2)(1 - e \cos \theta) \\ &= a(1 - e \cos \theta) - ae^2 + ae^3 \cos \theta \\ &\approx a(1 - e \cos \theta) \end{aligned}$$

**Problem 7.5**  $\ddot{x} + 9x = 10$

$$x = A \sin 3t + B \cos 3t + \frac{10}{9}$$

$$\dot{x} = 3A \cos 3t - 3B \sin 3t$$

At  $t = 0$ ,  $x = 5$ :

$$5 = A \sin(0) + B \cos(0) + \frac{10}{9}$$

$$5 = B + \frac{10}{9}$$

$$\therefore B = \frac{35}{9}$$

At  $t = 0$ ,  $\dot{x} = -3$ :

$$-3 = 3A \cos(0) - 3 \cdot \frac{35}{9} \sin(0)$$

$$-3 = 3A$$

$$A = -1$$



Thus

$$x = -\sin 3t + \frac{35}{9} \cos 3t + \frac{10}{9}$$

$$\dot{x} = -3 \cos 3t - \frac{35}{3} \sin 3t$$

At  $t = 1.2$ :

$$x = -\sin(3 \cdot 1.2) + \frac{35}{9} \cos(3 \cdot 1.2) + \frac{10}{9} = \underline{-1.934}$$

$$\dot{x} = -3 \cos(3 \cdot 1.2) - \frac{35}{3} \sin(3 \cdot 1.2) = \underline{7.853}$$

### Problem 7.6

$$\ddot{x} + 10x + 2\dot{y} = 0 \tag{1}$$

$$\ddot{y} + 3\dot{x} = 0 \tag{2}$$

Initial conditions (at  $t = 0$ ):

$$x_0 = 1 \tag{3}$$

$$\dot{x}_0 = -3 \tag{4}$$

$$y_0 = 2 \tag{5}$$

$$\dot{y}_0 = 4 \tag{6}$$

From (2)

$$\frac{d}{dt}(\dot{y} + 3x) = 0$$

$$\dot{y} + 3x = \text{const}$$

$$\dot{y} + 3x = \dot{y}_0 + 3x_0 = 4 + 3 \cdot 1 = 7$$

$$\dot{y} = 7 - 3x \tag{7}$$

Substitute (7) into (1):

$$\ddot{x} + 10x + 2(7 - 3x) = 0$$

$$\ddot{x} + 4x = -14$$

General solution:

$$x = A \sin 2t + B \cos 2t - \frac{7}{2} \tag{8}$$

$$\dot{x} = 2A \cos 2t - 2B \sin 2t \tag{9}$$

Evaluating (8) at  $t = 0$  and using (3),

$$1 = A \sin(0) + B \cos(0) - \frac{7}{2}$$

$$1 = B - \frac{7}{2}$$

$$B = \frac{9}{2} \tag{10}$$

Evaluating (9) at  $t = 0$  and using (4),

$$\begin{aligned}
 -3 &= 2A \cos(0) - 2B \sin(0) \\
 A &= -\frac{3}{2}
 \end{aligned} \tag{11}$$

With (10) and (11), (8) becomes

$$x = -\frac{3}{2} \sin 2t + \frac{9}{2} \cos 2t - \frac{7}{2} \tag{12}$$

Substituting (12) into (7) yields

$$\begin{aligned}
 \dot{y} &= 7 - 3 \left( -\frac{3}{2} \sin 2t + \frac{9}{2} \cos 2t - \frac{7}{2} \right) \\
 \dot{y} &= \frac{9}{2} \sin 2t - \frac{27}{2} \cos 2t + \frac{35}{2}
 \end{aligned} \tag{13}$$

Then

$$y = -\frac{9}{4} \cos 2t - \frac{27}{4} \sin 2t + \frac{35}{2} t + C \tag{14}$$

Evaluating (14) at  $t = 0$  and using (5), we get

$$\begin{aligned}
 2 &= -\frac{9}{4} \cos(0) - \frac{27}{4} \sin(0) + \frac{35}{2}(0) + C \\
 2 &= -\frac{9}{4} + C \\
 C &= \frac{17}{4}
 \end{aligned} \tag{15}$$

Substituting this into (14) yields

$$y = -\frac{9}{4} \cos 2t - \frac{27}{4} \sin 2t + \frac{35}{2} t + \frac{17}{4} \tag{16}$$

At  $t = 5$ , (12) and (14) yield, respectively,

$$\begin{aligned}
 x &= -\frac{3}{2} \sin(2 \cdot 5) + \frac{9}{2} \cos(2 \cdot 5) - \frac{7}{2} = \underline{-6.460} \\
 y &= -\frac{9}{4} \cos(2 \cdot 5) - \frac{27}{4} \sin(2 \cdot 5) + \frac{35}{2} \cdot 5 + \frac{17}{4} = \underline{97.31}
 \end{aligned}$$

### Problem 7.7

$$\begin{aligned}
 n &= \frac{2\pi}{90 \cdot 60} = 0.0011636 \text{ s}^{-1} \\
 t &= 15 \cdot 60 = 900 \text{ s}
 \end{aligned}$$

$$[\Phi_{\text{rr}}(t)] = \begin{bmatrix} 4 - 3 \cos nt & 0 & 0 \\ 6(\sin nt - nt) & 1 & 0 \\ 0 & 0 & \cos nt \end{bmatrix} = \begin{bmatrix} 2.5 & 0 & 0 \\ -1.087 & 1 & 0 \\ 0 & 0 & 0.5 \end{bmatrix}$$

$$[\Phi_{rv}(t)] = \begin{bmatrix} \frac{1}{n} \sin nt & \frac{2}{n}(1 - \cos nt) & 0 \\ \frac{2}{n}(\cos nt - 1) & \frac{1}{n}(4 \sin nt - 3nt) & 0 \\ 0 & 0 & \frac{1}{n} \sin nt \end{bmatrix} = \begin{bmatrix} 744.29 & 859.44 & 0 \\ -859.44 & 1 & 0 \\ 0 & 0 & 0.5 \end{bmatrix}$$

$$\{\delta \mathbf{r}_0\} = \begin{Bmatrix} 1 \\ 0 \\ 0 \end{Bmatrix} \text{ (km)} \quad \{\delta \mathbf{v}_0\} = \begin{Bmatrix} 0 \\ 0.01 \\ 0 \end{Bmatrix} \text{ (km/s)}$$

$$\{\delta \mathbf{r}\} = [\Phi_{rr}(t)]\{\delta \mathbf{r}_0\} + [\Phi_{rv}(t)]\{\delta \mathbf{v}_0\}$$

$$\begin{aligned} \{\delta \mathbf{r}\} &= [\Phi_{rr}(t)]\{\delta \mathbf{r}_0\} + [\Phi_{rv}(t)]\{\delta \mathbf{v}_0\} \\ &= \begin{bmatrix} 2.5 & 0 & 0 \\ -1.087 & 1 & 0 \\ 0 & 0 & 0.5 \end{bmatrix} \begin{Bmatrix} 1 \\ 0 \\ 0 \end{Bmatrix} + \begin{bmatrix} 744.29 & 859.44 & 0 \\ -859.44 & 1 & 0 \\ 0 & 0 & 0.5 \end{bmatrix} \begin{Bmatrix} 0 \\ 0.01 \\ 0 \end{Bmatrix} \\ &= \begin{Bmatrix} 2.5 \\ -1.087 \\ 0 \end{Bmatrix} + \begin{Bmatrix} 8.5944 \\ 2.7718 \\ 0 \end{Bmatrix} \\ &= \begin{Bmatrix} 11.094 \\ 1.6847 \\ 0 \end{Bmatrix} \end{aligned}$$

$$\|\delta \mathbf{r}\| = 11.222 \text{ km}$$

### Problem 7.8

$$v = \sqrt{\frac{\mu}{r}} = \sqrt{\frac{398600}{6600}} = 7.7714 \text{ km/s}$$

$$n = \frac{v}{r} = \frac{7.7714}{6600} = 0.0011775 \text{ s}^{-1}$$

$$T = \frac{2\pi}{n} = 5446.1 \text{ s}$$

$$t = \frac{T}{3} = 1778.7 \text{ s}$$

$$[\Phi_{rr}(t)] = \begin{bmatrix} 4 - 3 \cos nt & 0 & 0 \\ 6(\sin nt - nt) & 1 & 0 \\ 0 & 0 & \cos nt \end{bmatrix} = \begin{bmatrix} 5.5 & 0 & 0 \\ -7.3702 & 1 & 0 \\ 0 & 0 & -0.5 \end{bmatrix}$$

$$[\Phi_{rv}(t)] = \begin{bmatrix} \frac{1}{n} \sin nt & \frac{2}{n}(1 - \cos nt) & 0 \\ \frac{2}{n}(\cos nt - 1) & \frac{1}{n}(4 \sin nt - 3nt) & 0 \\ 0 & 0 & \frac{1}{n} \sin nt \end{bmatrix} = \begin{bmatrix} 735.49 & 2547.8 & 0 \\ -2547.8 & -2394.2 & 0 \\ 0 & 0 & 735.49 \end{bmatrix}$$

$$[\Phi_{vr}(t)] = \begin{bmatrix} 3n \sin nt & 0 & 0 \\ 6n(\cos nt - 1) & 0 & 0 \\ 0 & 0 & -n \sin nt \end{bmatrix} = \begin{bmatrix} 0.0030592 & 0 & 0 \\ -0.010597 & 0 & 0 \\ 0 & 0 & -0.0010197 \end{bmatrix}$$

$$[\Phi_{vv}(t)] = \begin{bmatrix} \cos nt & 2 \sin nt & 0 \\ -2 \sin nt & 4 \cos nt - 3 & 0 \\ 0 & 0 & \cos nt \end{bmatrix} = \begin{bmatrix} -0.5 & 1.7321 & 0 \\ -1.7321 & -5 & 0 \\ 0 & 0 & -0.5 \end{bmatrix}$$

$$\begin{aligned} \{\delta \mathbf{r}_f\} &= [\Phi_{rr}] \{\delta \mathbf{r}_0\} + [\Phi_{rv}] \{\delta \mathbf{v}_0^+\} \\ \begin{bmatrix} 0 \\ 0 \\ 0 \end{bmatrix} &= \begin{bmatrix} 5.5 & 0 & 0 \\ -7.3702 & 1 & 0 \\ 0 & 0 & -0.5 \end{bmatrix} \begin{bmatrix} 1 \\ 1 \\ 1 \end{bmatrix} + \begin{bmatrix} 735.49 & 2547.8 & 0 \\ -2547.8 & -2394.2 & 0 \\ 0 & 0 & 735.49 \end{bmatrix} \{\delta \mathbf{v}_0^+\} \\ \begin{bmatrix} 735.49 & 2547.8 & 0 \\ -2547.8 & -2394.2 & 0 \\ 0 & 0 & 735.49 \end{bmatrix} \{\delta \mathbf{v}_0^+\} &= - \begin{bmatrix} 5.5 & 0 & 0 \\ -7.3702 & 1 & 0 \\ 0 & 0 & -0.5 \end{bmatrix} \begin{bmatrix} 1 \\ 1 \\ 1 \end{bmatrix} = \begin{bmatrix} -5.5 \\ 6.3702 \\ 0.5 \end{bmatrix} \\ \{\delta \mathbf{v}_0^+\} &= \begin{bmatrix} 735.49 & 2547.8 & 0 \\ -2547.8 & -2394.2 & 0 \\ 0 & 0 & 735.49 \end{bmatrix}^{-1} \begin{bmatrix} -5.5 \\ 6.3702 \\ 0.5 \end{bmatrix} = \begin{bmatrix} -0.00064734 \\ -0.0019718 \\ 0.00067982 \end{bmatrix} \text{ (km/s)} \end{aligned}$$

$$\{\Delta \mathbf{v}_1\} = \{\delta \mathbf{v}_0^+\} - \{\delta \mathbf{v}_0^-\} = \begin{bmatrix} -0.00064734 \\ -0.0019718 \\ 0.00067982 \end{bmatrix} - \begin{bmatrix} 0 \\ 0 \\ 0.005 \end{bmatrix} = \begin{bmatrix} -0.00064734 \\ -0.0019718 \\ -0.0043202 \end{bmatrix} \text{ (km/s)}$$

$$\Delta v_1 = \|\Delta \mathbf{v}_1\| = 0.0047928 \text{ km/s}$$

$$\begin{aligned} \{\delta \mathbf{v}_f^-\} &= [\Phi_{vr}] \{\delta \mathbf{r}_0\} + [\Phi_{vv}] \{\delta \mathbf{v}_0^+\} \\ \{\delta \mathbf{v}_f^-\} &= \begin{bmatrix} 0.0030592 & 0 & 0 \\ -0.010597 & 0 & 0 \\ 0 & 0 & -0.0010197 \end{bmatrix} \begin{bmatrix} 1 \\ 1 \\ 1 \end{bmatrix} + \begin{bmatrix} -0.5 & 1.7321 & 0 \\ -1.7321 & -5 & 0 \\ 0 & 0 & -0.5 \end{bmatrix} \begin{bmatrix} -0.00064734 \\ -0.0019718 \\ 0.00067982 \end{bmatrix} \\ \{\delta \mathbf{v}_f^-\} &= \begin{bmatrix} 0.0030592 \\ -0.010597 \\ -0.0010197 \end{bmatrix} + \begin{bmatrix} -0.0030917 \\ 0.01098 \\ -0.00033991 \end{bmatrix} \\ \{\delta \mathbf{v}_f^-\} &= \begin{bmatrix} -0.00003248 \\ 0.00038312 \\ -0.0013596 \end{bmatrix} \text{ (km/s)} \\ \{\delta \mathbf{v}_f^+\} &= \begin{bmatrix} 0 \\ 0 \\ 0 \end{bmatrix} \end{aligned}$$

$$\{\Delta \mathbf{v}_2\} = \{\delta \mathbf{v}_f^+\} - \{\delta \mathbf{v}_f^-\} = \begin{bmatrix} 0 \\ 0 \\ 0 \end{bmatrix} - \begin{bmatrix} -0.00003248 \\ 0.00038312 \\ -0.0013596 \end{bmatrix} = \begin{bmatrix} 0.00003248 \\ -0.00038312 \\ 0.0013596 \end{bmatrix} \text{ (km/s)}$$

$$\Delta v_2 = \|\Delta \mathbf{v}_2\| = 0.001413 \text{ km/s}$$

$$v_{total} = \Delta v_1 + \Delta v_2 = 0.0047928 + 0.001413 = \underline{0.0062058 \text{ km/s}} = \underline{6.206 \text{ m/s}}$$

### Problem 7.9

$$t = \frac{T_0}{2}$$

$$nt = \frac{2\pi}{T_0} = \pi$$

$$[\Phi_{rr}(t)] = \begin{bmatrix} 4 - 3 \cos nt & 0 & 0 \\ 6(\sin nt - nt) & 1 & 0 \\ 0 & 0 & \cos nt \end{bmatrix} = \begin{bmatrix} 7 & 0 & 0 \\ -6\pi & 1 & 0 \\ 0 & 0 & -1 \end{bmatrix}$$

$$\begin{aligned}
 [\Phi_{rv}(t)] &= \begin{bmatrix} \frac{1}{n} \sin nt & \frac{2}{n}(1 - \cos nt) & 0 \\ \frac{2}{n}(\cos nt - 1) & \frac{1}{n}(4 \sin nt - 3nt) & 0 \\ 0 & 0 & \frac{1}{n} \sin nt \end{bmatrix} = \begin{bmatrix} 0 & \frac{4}{n} & 0 \\ -\frac{4}{n} & -\frac{3\pi}{n} & 0 \\ 0 & 0 & 0 \end{bmatrix} \\
 [\Phi_{vr}(t)] &= \begin{bmatrix} 3n \sin nt & 0 & 0 \\ 6n(\cos nt - 1) & 0 & 0 \\ 0 & 0 & -n \sin nt \end{bmatrix} = \begin{bmatrix} 0 & 0 & 0 \\ -12n & 0 & 0 \\ 0 & 0 & 0 \end{bmatrix} \\
 [\Phi_{vv}(t)] &= \begin{bmatrix} \cos nt & 2 \sin nt & 0 \\ -2 \sin nt & 4 \cos nt - 3 & 0 \\ 0 & 0 & \cos nt \end{bmatrix} = \begin{bmatrix} -1 & 0 & 0 \\ 0 & -7 & 0 \\ 0 & 0 & -1 \end{bmatrix}
 \end{aligned}$$

(a)

$$\{\delta \mathbf{r}_f\} = [\Phi_{rr}]\{\delta \mathbf{r}_0\} + [\Phi_{rv}]\{\delta \mathbf{v}_0^+\}$$

$$\begin{bmatrix} 0 \\ 0 \\ 0 \end{bmatrix} = \begin{bmatrix} 7 & 0 & 0 \\ -6\pi & 1 & 0 \\ 0 & 0 & -1 \end{bmatrix} \begin{bmatrix} \delta \rho \\ \delta y_0 \\ 0 \end{bmatrix} + \begin{bmatrix} 0 & \frac{4}{n} & 0 \\ -\frac{4}{n} & -\frac{3\pi}{n} & 0 \\ 0 & 0 & 0 \end{bmatrix} \begin{bmatrix} 0 \\ \delta v_0 \\ 0 \end{bmatrix}$$

$$\begin{bmatrix} 0 \\ 0 \\ 0 \end{bmatrix} = \begin{bmatrix} 7\delta\rho \\ -6\pi\delta\rho + \delta y_0 \\ 0 \end{bmatrix} + \begin{bmatrix} \frac{4\delta v_0}{n} \\ \frac{3\pi\delta v_0}{n} \\ 0 \end{bmatrix}$$

$$\begin{bmatrix} 7\delta\rho + \frac{4\delta v_0}{n} \\ -6\pi\delta\rho - \frac{3\pi\delta v_0}{n} + \delta y_0 \\ 0 \end{bmatrix} = \begin{bmatrix} 0 \\ 0 \\ 0 \end{bmatrix}$$

$$7\delta\rho + \frac{4\delta v_0}{n} = 0 \Rightarrow \delta v_0 = -\frac{7}{4}n\delta\rho$$

$$\delta y_0 = 6\pi\delta\rho + \frac{3\pi}{n}\left(-\frac{7}{4}n\delta\rho\right) = \frac{3}{4}\pi\delta\rho$$

$$\therefore \{\delta \mathbf{r}_0\} = \begin{bmatrix} \delta\rho \\ \frac{3}{4}\pi\delta\rho \\ 0 \end{bmatrix} \quad \{\delta \mathbf{v}_0^+\} = \begin{bmatrix} 0 \\ -\frac{7}{4}v\delta\rho \\ 0 \end{bmatrix}$$

(b)

$$\{\delta \mathbf{v}_f^-\} = [\Phi_{vr}]\{\delta \mathbf{r}_0\} + [\Phi_{vv}]\{\delta \mathbf{v}_0^+\}$$

$$\{\delta \mathbf{v}_f^-\} = \begin{bmatrix} 0 & 0 & 0 \\ -12n & 0 & 0 \\ 0 & 0 & 0 \end{bmatrix} \begin{bmatrix} \delta\rho \\ \frac{3}{4}\pi\delta\rho \\ 0 \end{bmatrix} + \begin{bmatrix} -1 & 0 & 0 \\ 0 & -7 & 0 \\ 0 & 0 & -1 \end{bmatrix} \begin{bmatrix} 0 \\ -\frac{7}{4}v\delta\rho \\ 0 \end{bmatrix}$$

$$\{\delta \mathbf{v}_f^-\} = \begin{bmatrix} 0 \\ -12n\delta\rho \\ 0 \end{bmatrix} + \begin{bmatrix} 0 \\ \frac{49}{4}n\delta\rho \\ 0 \end{bmatrix} = \begin{bmatrix} 0 \\ \frac{1}{4}n\delta\rho \\ 0 \end{bmatrix} = \begin{bmatrix} 0 \\ \frac{1}{2}\frac{\pi\delta\rho}{T_0} \\ 0 \end{bmatrix}$$

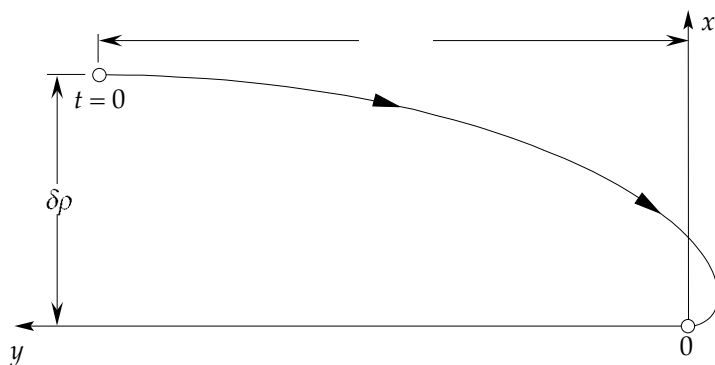
**Problem 7.10**

$$nt = 2\pi \quad n = \frac{2\pi}{T}$$

$$[\Phi_{rr}(t)] = \begin{bmatrix} 4 - 3 \cos nt & 0 & 0 \\ 6(\sin nt - nt) & 1 & 0 \\ 0 & 0 & \cos nt \end{bmatrix} = \begin{bmatrix} 1 & 0 & 0 \\ -12\pi & 1 & 0 \\ 0 & 0 & 1 \end{bmatrix}$$

$$[\Phi_{rv}(t)] = \begin{bmatrix} \frac{1}{n} \sin nt & \frac{2}{n}(1 - \cos nt) & 0 \\ \frac{2}{n}(\cos nt - 1) & \frac{1}{n}(4 \sin nt - 3nt) & 0 \\ 0 & 0 & \frac{1}{n} \sin nt \end{bmatrix} = \begin{bmatrix} 0 & 0 & 0 \\ 0 & -\frac{6\pi}{n} & 0 \\ 0 & 0 & 0 \end{bmatrix}$$

$$[\Phi_{vr}(t)] = \begin{bmatrix} 3n \sin nt & 0 & 0 \\ 6n(\cos nt - 1) & 0 & 0 \\ 0 & 0 & -n \sin nt \end{bmatrix} = \begin{bmatrix} 0 & 0 & 0 \\ 0 & 0 & 0 \\ 0 & 0 & 0 \end{bmatrix}$$

$$[\Phi_{vv}(t)] = \begin{bmatrix} \cos nt & 2 \sin nt & 0 \\ -2 \sin nt & 4 \cos nt - 3 & 0 \\ 0 & 0 & \cos nt \end{bmatrix} = \begin{bmatrix} 1 & 0 & 0 \\ 0 & 1 & 0 \\ 0 & 0 & 1 \end{bmatrix}$$

$$\{\delta \mathbf{r}_f\} = [\Phi_{rr}]\{\delta \mathbf{r}_0\} + [\Phi_{rv}]\{\delta \mathbf{v}_0^+\}$$

$$\begin{bmatrix} 0 \\ 0 \\ 0 \end{bmatrix} = \begin{bmatrix} 1 & 0 & 0 \\ -12\pi & 1 & 0 \\ 0 & 0 & 1 \end{bmatrix} \begin{bmatrix} 0 \\ \delta y_0 \\ 0 \end{bmatrix} + \begin{bmatrix} 0 & 0 & 0 \\ 0 & -\frac{6\pi}{n} & 0 \\ 0 & 0 & 0 \end{bmatrix} \begin{bmatrix} \delta u_0^+ \\ \delta v_0^+ \\ 0 \end{bmatrix}$$

$$\begin{bmatrix} 0 \\ 0 \\ 0 \end{bmatrix} = \begin{bmatrix} 0 \\ \delta y_0 \\ 0 \end{bmatrix} + \begin{bmatrix} 0 \\ -\frac{6\pi \delta v_0^+}{n} \\ 0 \end{bmatrix}$$

$$\begin{bmatrix} 0 \\ 0 \\ 0 \end{bmatrix} = \begin{bmatrix} 0 \\ \delta y_0 - \frac{6\pi \delta v_0^+}{n} \\ 0 \end{bmatrix} \Rightarrow \delta v_0^+ = \frac{n \delta y_0}{6\pi}$$

Thus, assuming a Hohmann transfer,  $\delta u_0^+ = 0$ ,

$$\{\delta \mathbf{v}_0^+\} = \begin{bmatrix} 0 \\ \frac{n \delta y_0}{6\pi} \\ 0 \end{bmatrix}$$

$$\{\Delta \mathbf{v}_1\} = \{\delta \mathbf{v}_{0^+}\} - \{\delta \mathbf{v}_{0^-}\} = \begin{Bmatrix} 0 \\ \frac{n\delta y_0}{6\pi} \\ 0 \end{Bmatrix} - \begin{Bmatrix} 0 \\ 0 \\ 0 \end{Bmatrix} = \begin{Bmatrix} 0 \\ \frac{n\delta y_0}{6\pi} \\ 0 \end{Bmatrix}$$

$$\Delta v_1 = \|\Delta \mathbf{v}_1\| = \frac{n\delta y_0}{6\pi}$$

$$\{\delta \mathbf{v}_{f^-}\} = [\Phi_{\mathbf{v}\mathbf{r}}]\{\delta \mathbf{r}_0\} + [\Phi_{\mathbf{v}\mathbf{v}}]\{\delta \mathbf{v}_{0^+}\}$$

$$\{\delta \mathbf{v}_{f^-}\} = \begin{bmatrix} 0 & 0 & 0 \\ 0 & 0 & 0 \\ 0 & 0 & 0 \end{bmatrix} \begin{Bmatrix} 0 \\ \delta y_0 \\ 0 \end{Bmatrix} + \begin{bmatrix} 1 & 0 & 0 \\ 0 & 1 & 0 \\ 0 & 0 & 1 \end{bmatrix} \begin{Bmatrix} 0 \\ \frac{n\delta y_0}{6\pi} \\ 0 \end{Bmatrix}$$

$$\{\delta \mathbf{v}_{f^-}\} = \begin{Bmatrix} 0 \\ \frac{n\delta y_0}{6\pi} \\ 0 \end{Bmatrix}$$

$$\{\Delta \mathbf{v}_2\} = \{\delta \mathbf{v}_{f^+}\} - \{\delta \mathbf{v}_{f^-}\} = \begin{Bmatrix} 0 \\ 0 \\ 0 \end{Bmatrix} - \begin{Bmatrix} 0 \\ \frac{n\delta y_0}{6\pi} \\ 0 \end{Bmatrix} = \begin{Bmatrix} 0 \\ -\frac{n\delta y_0}{6\pi} \\ 0 \end{Bmatrix}$$

$$\Delta v_2 = \|\Delta \mathbf{v}_2\| = \frac{n\delta y_0}{6\pi}$$

$$\Delta v_{total} = \Delta v_1 + \Delta v_2 = \frac{n\delta y_0}{6\pi} + \frac{n\delta y_0}{6\pi} = \frac{n\delta y_0}{3\pi} = \frac{2\delta y_0}{3T}$$

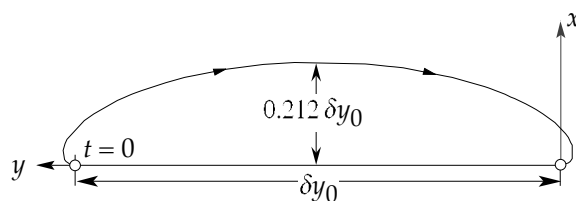

### Problem 7.11

$$n = \frac{2\pi}{2 \cdot 3600} = 0.00087266 \text{ s}^{-1}$$

$$t = 30 \cdot 60 = 1800 \text{ s}$$

$$nt = \frac{\pi}{2}$$

$$[\Phi_{\mathbf{r}\mathbf{r}}(t)] = \begin{bmatrix} 4 - 3 \cos nt & 0 & 0 \\ 6(\sin nt - nt) & 1 & 0 \\ 0 & 0 & \cos nt \end{bmatrix} = \begin{bmatrix} 4 & 0 & 0 \\ -3.425 & 1 & 0 \\ 0 & 0 & 0 \end{bmatrix}$$

$$[\Phi_{\mathbf{r}\mathbf{v}}(t)] = \begin{bmatrix} \frac{1}{n} \sin nt & \frac{2}{n}(1 - \cos nt) & 0 \\ \frac{2}{n}(\cos nt - 1) & \frac{1}{n}(4 \sin nt - 3nt) & 0 \\ 0 & 0 & \frac{1}{n} \sin nt \end{bmatrix} = \begin{bmatrix} 1146 & 2292 & 0 \\ -2292 & -816.3 & 0 \\ 0 & 0 & 1146 \end{bmatrix}$$

$$[\Phi_{\mathbf{v}\mathbf{r}}(t)] = \begin{bmatrix} 3n \sin nt & 0 & 0 \\ 6n(\cos nt - 1) & 0 & 0 \\ 0 & 0 & -n \sin nt \end{bmatrix} = \begin{bmatrix} 0.002618 & 0 & 0 \\ -0.005236 & 0 & 0 \\ 0 & 0 & -0.0008727 \end{bmatrix}$$

$$[\Phi_{VV}(t)] = \begin{bmatrix} \cos nt & 2 \sin nt & 0 \\ -2 \sin nt & 4 \cos nt - 3 & 0 \\ 0 & 0 & \cos nt \end{bmatrix} = \begin{bmatrix} 0 & 2 & 0 \\ -2 & -3 & 0 \\ 0 & 0 & 0 \end{bmatrix}$$

$$\{\delta \mathbf{r}_f\} = [\Phi_{rR}]\{\delta \mathbf{r}_0\} + [\Phi_{rV}]\{\delta \mathbf{v}_0^+\}$$

$$\{\delta \mathbf{r}_f\} = \begin{bmatrix} 4 & 0 & 0 \\ -3.425 & 1 & 0 \\ 0 & 0 & 0 \end{bmatrix} \begin{bmatrix} 0 \\ 6 \\ 0 \end{bmatrix} + \begin{bmatrix} 1146 & 2292 & 0 \\ -2292 & -816.3 & 0 \\ 0 & 0 & 1146 \end{bmatrix} \begin{Bmatrix} 0 \\ -0.003 \\ 0 \end{Bmatrix}$$

$$\{\delta \mathbf{r}_f\} = \begin{Bmatrix} 0 \\ 6 \\ 0 \end{Bmatrix} + \begin{Bmatrix} -6.875 \\ 2.449 \\ 0 \end{Bmatrix} = \begin{Bmatrix} -6.875 \\ 8.449 \\ 0 \end{Bmatrix} \text{ (km)}$$

$$\|\delta \mathbf{r}_f\| = 10.89 \text{ km}$$

$$\{\delta \mathbf{v}_f\} = [\Phi_{vR}]\{\delta \mathbf{r}_0\} + [\Phi_{vV}]\{\delta \mathbf{v}_0^+\}$$

$$\{\delta \mathbf{v}_f\} = \begin{bmatrix} 0.002618 & 0 & 0 \\ -0.005236 & 0 & 0 \\ 0 & 0 & -0.0008727 \end{bmatrix} \begin{bmatrix} 0 \\ 6 \\ 0 \end{bmatrix} + \begin{bmatrix} 0 & 2 & 0 \\ -2 & -3 & 0 \\ 0 & 0 & 0 \end{bmatrix} \begin{Bmatrix} 0 \\ -0.003 \\ 0 \end{Bmatrix}$$

$$\{\delta \mathbf{v}_f\} = \begin{Bmatrix} 0 \\ 0 \\ 0 \end{Bmatrix} + \begin{Bmatrix} -0.006 \\ 0.009 \\ 0 \end{Bmatrix} = \begin{Bmatrix} 0 \\ 0 \\ 0 \end{Bmatrix} + \begin{Bmatrix} -0.006 \\ 0.009 \\ 0 \end{Bmatrix} \text{ (km/s)}$$

$$\|\delta \mathbf{v}_f\| = 0.01082 \text{ km/s}$$

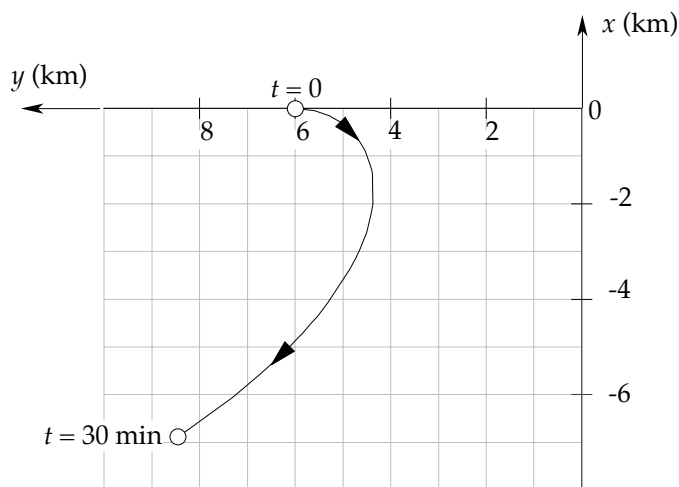

**Problem 7.12** Use C-W frame attached to original location of satellite in GEO.

$$n = \frac{2\pi + \frac{2\pi}{365.26}}{24 \cdot 3600} = 7.292 \times 10^{-5} \text{ s}^{-1}$$

First determine the relative position and velocity after two hours.

$$t = 2 \cdot 3600 = 7200 \text{ s}$$

$$nt = 0.1671\pi$$



$$\begin{aligned} [\Phi_{rr}(t)] &= \begin{bmatrix} 4 - 3 \cos nt & 0 \\ 6(\sin nt - nt) & 1 \end{bmatrix} = \begin{bmatrix} 1.404 & 0 \\ -0.1427 & 1 \end{bmatrix} \\ [\Phi_{rv}(t)] &= \begin{bmatrix} \frac{1}{n} \sin nt & \frac{2}{n}(1 - \cos nt) \\ \frac{2}{n}(\cos nt - 1) & \frac{1}{n}(4 \sin nt - 3nt) \end{bmatrix} = \begin{bmatrix} 6874 & 3694 \\ -3694 & 5895 \end{bmatrix} \\ [\Phi_{vr}(t)] &= \begin{bmatrix} 3n \sin nt & 0 \\ 6n(\cos nt - 1) & 0 \end{bmatrix} = \begin{bmatrix} 10.97 \times 10^{-5} & 0 \\ -5.893 \times 10^{-5} & 0 \end{bmatrix} \\ [\Phi_{vv}(t)] &= \begin{bmatrix} \cos nt & 2 \sin nt \\ -2 \sin nt & 4 \cos nt - 3 \end{bmatrix} = \begin{bmatrix} 0.8653 & 1.002 \\ -1.002 & 0.4612 \end{bmatrix} \\ \{\delta \mathbf{r}_2\} &= [\Phi_{rr}]\{\delta \mathbf{r}_0\} + [\Phi_{rv}]\{\delta \mathbf{v}_0\} \\ \begin{Bmatrix} -10 \\ 10 \end{Bmatrix} &= \begin{bmatrix} 1.404 & 0 \\ -0.1427 & 1 \end{bmatrix} \begin{Bmatrix} 0 \\ 0 \end{Bmatrix} + \begin{bmatrix} 6874 & 3694 \\ -3694 & 5895 \end{bmatrix} \{\delta \mathbf{v}_0\} \\ \begin{bmatrix} 6874 & 3694 \\ -3694 & 5895 \end{bmatrix} \{\delta \mathbf{v}_0\} &= \begin{Bmatrix} -10 \\ 10 \end{Bmatrix} \\ \{\delta \mathbf{v}_0\} &= \begin{bmatrix} 6874 & 3694 \\ -3694 & 5895 \end{bmatrix}^{-1} \begin{Bmatrix} -10 \\ 10 \end{Bmatrix} = \begin{Bmatrix} -0.00177 \\ 0.000587 \end{Bmatrix} \text{ (km/s)} \\ \{\delta \mathbf{v}_2^-\} &= [\Phi_{vr}]\{\delta \mathbf{r}_0\} + [\Phi_{vv}]\{\delta \mathbf{v}_0\} \\ \{\delta \mathbf{v}_2^-\} &= \begin{bmatrix} 10.97 \times 10^{-5} & 0 \\ -5.893 \times 10^{-5} & 0 \end{bmatrix} \begin{Bmatrix} 0 \\ 0 \end{Bmatrix} + \begin{bmatrix} 0.8653 & 1.002 \\ -1.002 & 0.4612 \end{bmatrix} \begin{Bmatrix} -0.00177 \\ 0.000587 \end{Bmatrix} \\ \{\delta \mathbf{v}_2^-\} &= \begin{Bmatrix} -0.0009434 \\ 0.002045 \end{Bmatrix} \text{ (km/s)} \end{aligned}$$

Initiate rendezvous with the origin.

$$t = 6 \cdot 3600 = 21600 \text{ s}$$

$$nt = 0.5014\pi$$

$$\begin{aligned} \{\delta \mathbf{r}_6\} &= [\Phi_{rr}]\{\delta \mathbf{r}_2\} + [\Phi_{rv}]\{\delta \mathbf{v}_2^+\} \\ \begin{Bmatrix} 0 \\ 0 \end{Bmatrix} &= \begin{bmatrix} 4.013 & 0 \\ -3.451 & 1 \end{bmatrix} \begin{Bmatrix} -10 \\ 10 \end{Bmatrix} + \begin{bmatrix} 13710 & 27540 \\ -27540 & -9947 \end{bmatrix} \{\delta \mathbf{v}_2^+\} \\ \begin{bmatrix} 13710 & 27540 \\ -27540 & -9947 \end{bmatrix} \{\delta \mathbf{v}_2^+\} &= -\begin{bmatrix} 4.013 & 0 \\ -3.451 & 1 \end{bmatrix} \begin{Bmatrix} -10 \\ 10 \end{Bmatrix} \\ \begin{bmatrix} 13710 & 27540 \\ -27540 & -9947 \end{bmatrix} \{\delta \mathbf{v}_2^+\} &= \begin{Bmatrix} 40.13 \\ -44.51 \end{Bmatrix} \\ \{\delta \mathbf{v}_2^+\} &= \begin{bmatrix} 13710 & 27540 \\ -27540 & -9947 \end{bmatrix}^{-1} \begin{Bmatrix} 40.13 \\ -44.51 \end{Bmatrix} = \begin{Bmatrix} 0.001329 \\ 0.0007954 \end{Bmatrix} \text{ (km/s)} \\ \{\delta \mathbf{v}_6^-\} &= [\Phi_{vr}]\{\delta \mathbf{r}_0\} + [\Phi_{vv}]\{\delta \mathbf{v}_2^+\} \\ \{\delta \mathbf{v}_6^-\} &= \begin{bmatrix} 0.0002188 & 0 \\ -0.0004394 & 0 \end{bmatrix} \begin{Bmatrix} -10 \\ 10 \end{Bmatrix} + \begin{bmatrix} -0.0043 & 2 \\ -2 & -3.017 \end{bmatrix} \begin{Bmatrix} 0.001329 \\ 0.0007954 \end{Bmatrix} \\ \{\delta \mathbf{v}_6^-\} &= \begin{Bmatrix} -0.002188 \\ 0.004394 \end{Bmatrix} + \begin{Bmatrix} 0.001585 \\ -0.005057 \end{Bmatrix} = \begin{Bmatrix} -0.0006025 \\ -0.000663 \end{Bmatrix} \text{ (km/s)} \end{aligned}$$

$$\{\Delta \mathbf{v}_2\} = \{\delta \mathbf{v}_2^+\} - \{\delta \mathbf{v}_2^-\} = \begin{Bmatrix} 0.001329 \\ 0.0007954 \end{Bmatrix} - \begin{Bmatrix} -0.0009434 \\ 0.002045 \end{Bmatrix} = \begin{Bmatrix} 0.002272 \\ -0.00125 \end{Bmatrix} \text{ (km/s)}$$

$$\Delta v_2 = \|\Delta \mathbf{v}_2\| = 0.002593 \text{ km/s}$$

$$\{\Delta \mathbf{v}_6\} = \{\delta \mathbf{v}_6^+\} - \{\delta \mathbf{v}_6^-\} = \begin{Bmatrix} 0 \\ 0 \end{Bmatrix} - \begin{Bmatrix} -0.0006025 \\ -0.000663 \end{Bmatrix} = \begin{Bmatrix} 0.0006025 \\ 0.000663 \end{Bmatrix} \text{ (km/s)}$$

$$\Delta v_6 = \|\Delta \mathbf{v}_6\| = 0.0008958 \text{ km/s}$$

$$\Delta v_{total} = \Delta v_2 + \Delta v_6 = 0.002593 + 0.0008958 = 0.003489 \text{ km/s} = \underline{3.489 \text{ m/s}}$$

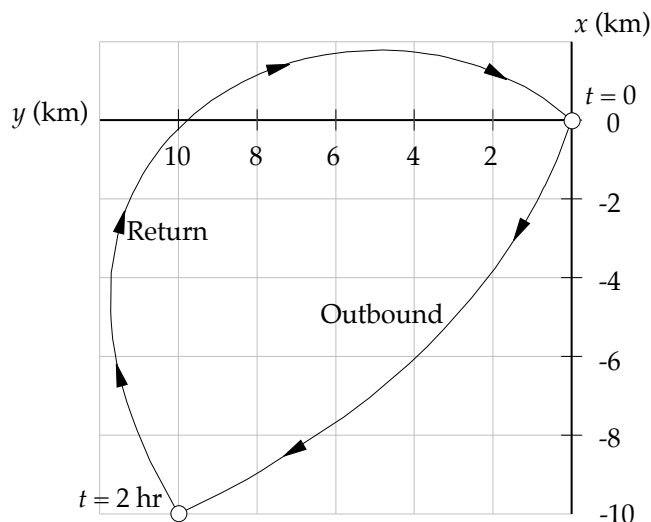

**Problem 7.13** Design problem.

**Problem 7.14**

$$n = \sqrt{\frac{398600}{6600}} = 0.0011775 \text{ s}^{-1}$$

$$\delta v = -\frac{3}{2}n\delta x = -\frac{3}{2} \cdot 0.0011775 \cdot 5 = 0.0088311 \text{ km/s} = \underline{8.8311 \text{ m/s}}$$

**Problem 7.15**

$$nt = \frac{\pi}{2}$$

$$[\Phi_{rr}(t)] = \begin{bmatrix} 4 - 3 \cos nt & 0 \\ 6(\sin nt - nt) & 1 \end{bmatrix} = \begin{bmatrix} 4 & 0 \\ -3.425 & 1 \end{bmatrix}$$

$$[\Phi_{rv}(t)] = \begin{bmatrix} \frac{1}{n} \sin nt & \frac{2}{n}(1 - \cos nt) \\ \frac{2}{n}(\cos nt - 1) & \frac{1}{n}(4 \sin nt - 3nt) \end{bmatrix} = \begin{bmatrix} \frac{1}{n} & \frac{2}{n} \\ -\frac{2}{n} & -\frac{0.7124}{n} \end{bmatrix}$$

$$\{\delta \mathbf{r}_f\} = [\Phi_{rr}]\{\delta \mathbf{r}_0\} + [\Phi_{rv}]\{\delta \mathbf{v}_0\}$$

$$\{\delta \mathbf{r}_f\} = \begin{bmatrix} 4 & 0 \\ -3.425 & 1 \end{bmatrix} \begin{Bmatrix} \delta r \\ \pi \delta r \end{Bmatrix} + \begin{bmatrix} \frac{1}{n} & \frac{2}{n} \\ -\frac{2}{n} & -\frac{0.7124}{n} \end{bmatrix} \begin{Bmatrix} \frac{n\pi\delta r}{16} \\ -\frac{7n\delta r}{4} \end{Bmatrix}$$

$$\{\delta \mathbf{r}_f\} = \begin{Bmatrix} 4\delta r \\ -0.2832\delta r \end{Bmatrix} + \begin{Bmatrix} -3.304\delta r \\ 0.854\delta r \end{Bmatrix} = \begin{Bmatrix} 0.6963\delta r \\ 0.85708\delta r \end{Bmatrix}$$

$$d = \|\delta\mathbf{r}_f\| = 0.9004\delta r$$

**Problem 7.16**

$$nt = \pi \quad nt = \pi$$

$$[\Phi_{rr}(t)] = \begin{bmatrix} 4 - 3 \cos nt & 0 \\ 6(\sin nt - nt) & 1 \end{bmatrix} = \begin{bmatrix} 7 & 0 \\ -18.85 & 1 \end{bmatrix}$$

$$[\Phi_{rv}(t)] = \begin{bmatrix} \frac{1}{n} \sin nt & \frac{2}{n}(1 - \cos nt) \\ \frac{2}{n}(\cos nt - 1) & \frac{1}{n}(4 \sin nt - 3nt) \end{bmatrix} = \begin{bmatrix} 0 & \frac{4}{n} \\ -\frac{4}{n} & -\frac{9.425}{n} \end{bmatrix}$$

$$\{\delta\mathbf{r}_f\} = [\Phi_{rr}]\{\delta\mathbf{r}_0\} + [\Phi_{rv}]\{\delta\mathbf{v}_0\}$$

$$\begin{bmatrix} 0 \\ 0 \end{bmatrix} = \begin{bmatrix} 7 & 0 \\ -18.85 & 1 \end{bmatrix} \begin{bmatrix} \delta x_0 \\ 0 \end{bmatrix} + \begin{bmatrix} 0 & \frac{4}{n} \\ -\frac{4}{n} & -\frac{9.425}{n} \end{bmatrix} \{\delta\mathbf{v}_0\}$$

$$\begin{bmatrix} 0 & \frac{4}{n} \\ -\frac{4}{n} & -\frac{9.425}{n} \end{bmatrix} \{\delta\mathbf{v}_0\} = \begin{bmatrix} -7\delta x_0 \\ 18.85\delta x_0 \end{bmatrix}$$

$$\{\delta\mathbf{v}_0\} = \begin{bmatrix} 0 & \frac{4}{n} \\ -\frac{4}{n} & -\frac{9.425}{n} \end{bmatrix}^{-1} \begin{bmatrix} -7\delta x_0 \\ 18.85\delta x_0 \end{bmatrix}$$

$$\{\delta\mathbf{v}_0\} = \begin{bmatrix} -0.589n\delta x_0 \\ -1.75n\delta x_0 \end{bmatrix}$$

or

$$\delta\mathbf{v}_0 = -0.589n\delta x_0 \hat{\mathbf{i}} - 1.75n\delta x_0 \hat{\mathbf{j}} \text{ (km/s)}$$

**Problem 7.17**

$$nt = \frac{\pi}{4}$$

$$[\Phi_{rr}(t)] = \begin{bmatrix} 4 - 3 \cos nt & 0 \\ 6(\sin nt - nt) & 1 \end{bmatrix} = \begin{bmatrix} 1.879 & 0 \\ -0.4697 & 1 \end{bmatrix}$$

$$[\Phi_{rv}(t)] = \begin{bmatrix} \frac{1}{n} \sin nt & \frac{2}{n}(1 - \cos nt) \\ \frac{2}{n}(\cos nt - 1) & \frac{1}{n}(4 \sin nt - 3nt) \end{bmatrix} = \begin{bmatrix} \frac{0.7071}{n} & \frac{0.5858}{n} \\ -\frac{0.5858}{n} & \frac{0.4722}{n} \end{bmatrix}$$

$$\{\delta\mathbf{r}_f\} = [\Phi_{rr}]\{\delta\mathbf{r}_0\} + [\Phi_{rv}]\{\delta\mathbf{v}_0\}$$

$$\begin{bmatrix} 0 \\ 0 \end{bmatrix} = \begin{bmatrix} 1.879 & 0 \\ -0.4697 & 1 \end{bmatrix} \begin{bmatrix} -d \\ \delta y_0 \end{bmatrix} + \begin{bmatrix} \frac{0.7071}{n} & \frac{0.5858}{n} \\ -\frac{0.5858}{n} & \frac{0.4722}{n} \end{bmatrix} \{\delta\mathbf{v}_0\}$$

$$\begin{bmatrix} 0 \\ 0 \end{bmatrix} = \begin{bmatrix} -1.879d \\ 0.4697d + \delta y_0 \end{bmatrix} + \begin{bmatrix} \frac{0.5858\delta v_0}{n} \\ \frac{0.4722\delta v_0}{n} \end{bmatrix}$$

$$\begin{bmatrix} \frac{0.5858\delta v_0}{n} - 1.879d \\ \frac{0.4722\delta v_0}{n} + 0.4697d + \delta y_0 \end{bmatrix} = \begin{bmatrix} 0 \\ 0 \end{bmatrix}$$

$$\begin{bmatrix} 0 & \frac{0.5858}{n} \\ 1 & \frac{0.4722}{n} \end{bmatrix} \begin{Bmatrix} \delta y_0 \\ \delta v_0 \end{Bmatrix} = \begin{Bmatrix} 1.879d \\ -0.4697d \end{Bmatrix}$$

$$\begin{Bmatrix} \delta y_0 \\ \delta v_0 \end{Bmatrix} = \begin{bmatrix} 0 & \frac{0.5858}{n} \\ 1 & \frac{0.4722}{n} \end{bmatrix}^{-1} \begin{Bmatrix} 1.879d \\ -0.4697d \end{Bmatrix}$$

$$\begin{Bmatrix} \delta y_0 \\ \delta v_0 \end{Bmatrix} = \begin{bmatrix} -0.8062 & 1 \\ 1.707n & 0 \end{bmatrix} \begin{Bmatrix} 1.879d \\ -0.4697d \end{Bmatrix} = \begin{Bmatrix} -1.984d \\ 3.207nd \end{Bmatrix}$$

$$\underline{\delta y_0 = -1.984d}$$

---



**Problem 8.1**

$$\mu_{\text{sun}} = 132.7 \times 10^9 \text{ km}^3/\text{s}^2$$

$$\mu_{\text{earth}} = 398\,600 \text{ km}^3/\text{s}^2$$

$$R_{\text{earth}} = 147.4 \times 10^6 \text{ km}$$

$$r_{\text{earth}} = 6378 \text{ km}$$

$$a = \frac{1}{2}(R_{\text{earth}} + R_2) = \frac{1}{2}(147.4 \times 10^6 + 120 \times 10^6) = 138.7 \times 10^6 \text{ km}$$

Heliocentric spacecraft velocity at earth's sphere of influence:

$$V^{(v)} = \sqrt{\mu_{\text{sun}} \left( \frac{2}{R_{\text{earth}}} - \frac{1}{a} \right)} = \sqrt{132.7 \times 10^9 \left( \frac{2}{147.4 \times 10^6} - \frac{1}{138.7 \times 10^6} \right)} = 28.43 \text{ km/s}$$

Heliocentric velocity of earth:

$$V_{\text{earth}} = \sqrt{\frac{\mu_{\text{sun}}}{R_{\text{earth}}}} = \sqrt{\frac{132.7 \times 10^9}{149.6 \times 10^6}} = 30.06 \text{ km/s}$$

$$\therefore v_{\infty} = V_{\text{earth}} - V^{(v)} = 30.06 - 28.43 = 1.579 \text{ km/s}$$

Geocentric spacecraft velocity of spacecraft at perigee of departure hyperbola:

$$v_p = \sqrt{v_{\infty}^2 + \frac{2\mu_{\text{earth}}}{r_p}} = \sqrt{1.579^2 + \frac{2 \cdot 398\,600}{6378 + 200}} = 11.12 \text{ km/s}$$

Geocentric spacecraft velocity in its circular parking orbit:

$$v_c = \sqrt{\frac{\mu_{\text{earth}}}{r}} = \sqrt{\frac{398\,600}{6378 + 200}} = 7.784 \text{ km/s}$$

$$\therefore \Delta v = v_p - v_c = 11.12 - 7.784 = 3.337 \text{ km/s}$$

**Problem 8.2**

$$\mu_{\text{sun}} = 132.7 \times 10^9 \text{ km}^3/\text{s}^2$$

$$\mu_{\text{earth}} = 398\,600 \text{ km}^3/\text{s}^2$$

$$\mu_{\text{Mercury}} = 22\,930 \text{ km}^3/\text{s}^2$$

$$R_{\text{earth}} = 149.6 \times 10^6 \text{ km}$$

$$R_{\text{Mercury}} = 57.91 \times 10^6 \text{ km}$$

$$r_{\text{earth}} = 6378 \text{ km}$$

$$r_{\text{Mercury}} = 2440 \text{ km}$$

$$V_{\text{earth}} = \sqrt{\frac{\mu_{\text{sun}}}{R_{\text{earth}}}} = \sqrt{\frac{132.7 \times 10^9}{149.6 \times 10^6}} = 29.78 \text{ km/s}$$

$$V_{\text{Mercury}} = \sqrt{\frac{\mu_{\text{sun}}}{R_{\text{Mercury}}}} = \sqrt{\frac{132.7 \times 10^9}{57.91 \times 10^6}} = 47.87 \text{ km/s}$$

Semimajor axis of Hohmann transfer ellipse:

$$a = \frac{1}{2} (R_{\text{Earth}} + R_{\text{Mercury}}) = \frac{1}{2} (149.6 \times 10^6 + 57.91 \times 10^6) = 103.8 \times 10^6 \text{ km}$$

Departure from earth:

Spacecraft heliocentric velocity:

$$V^{(v)} = \sqrt{\mu_{\text{Sun}} \left( \frac{2}{R_{\text{Earth}}} - \frac{1}{a} \right)} = \sqrt{132.7 \times 10^9 \left( \frac{2}{149.6 \times 10^6} - \frac{1}{103.8 \times 10^6} \right)} = 22.25 \text{ km/s}$$

$$\therefore v_{\infty} = V_{\text{Earth}} - V^{(v)} = 29.78 - 22.25 = 7.532 \text{ km/s}$$

Spacecraft geocentric velocity in circular parking orbit:

$$v_c = \sqrt{\frac{\mu_{\text{Earth}}}{r_p}} = \sqrt{\frac{398\,600}{6378 + 150}} = 7.814 \text{ km/s}$$

Spacecraft geocentric velocity at perigee of departure hyperbola:

$$v_p = \sqrt{v_{\infty}^2 + \frac{2\mu_{\text{Earth}}}{r_p}} = \sqrt{7.532^2 + \frac{2 \cdot 398\,600}{6378 + 150}} = 13.37 \text{ km/s}$$

$$\therefore \Delta v_1 = v_p - v_c = 13.37 - 7.814 = 9.611 \text{ km/s}$$

Arrival at Mercury:

Spacecraft heliocentric velocity:

$$V^{(v)} = \sqrt{\mu_{\text{Sun}} \left( \frac{2}{R_{\text{Mercury}}} - \frac{1}{a} \right)} = \sqrt{132.7 \times 10^9 \left( \frac{2}{57.91 \times 10^6} - \frac{1}{103.8 \times 10^6} \right)} = 57.48 \text{ km/s}$$

$$\therefore v_{\infty} = V^{(v)} - V_{\text{Mercury}} = 57.48 - 47.87 = 9.611 \text{ km/s}$$

Spacecraft velocity relative to Mercury at periapse of approach hyperbola:

$$v_p = \sqrt{v_{\infty}^2 + \frac{2\mu_{\text{Mercury}}}{r_p}} = \sqrt{9.611^2 + \frac{2 \cdot 22\,930}{2440 + 150}} = 10.49 \text{ km/s}$$

Spacecraft parking orbit speed relative to Mercury:

$$v_c = \sqrt{\frac{\mu_{\text{Mercury}}}{r_p}} = \sqrt{\frac{22\,930}{2440 + 150}} = 2.975 \text{ km/s}$$

$$\therefore \Delta v_2 = v_p - v_c = 10.49 - 2.975 = 7.516 \text{ km/s}$$

$$\Delta v_{\text{total}} = \Delta v_1 + \Delta v_2 = 9.611 + 7.516 = 15.03 \text{ km/s}$$

### Problem 8.3

$$r_{\text{SOI}} = R \left( \frac{m_p}{m_{\text{Sun}}} \right)$$

$$m_{\text{Sun}} = 1.989 \times 10^{30} \text{ kg}$$

Mercury:

$$R = 57.91 \times 10^6 \text{ km}$$

$$m_p = 3.302 \times 10^{23} \text{ kg}$$

$$r_{SOI} = 57.91 \times 10^6 \left( \frac{3.302 \times 10^{23}}{1.989 \times 10^{30}} \right) = \underline{1.124 \times 10^5 \text{ km}}$$

Venus:

$$R = 108.2 \times 10^6 \text{ km}$$

$$m_p = 4.869 \times 10^{24} \text{ kg}$$

$$r_{SOI} = 108.2 \times 10^6 \left( \frac{4.869 \times 10^{24}}{1.989 \times 10^{30}} \right) = \underline{6.162 \times 10^5 \text{ km}}$$

Mars:

$$R = 227.9 \times 10^6 \text{ km}$$

$$m_p = 6.419 \times 10^{23} \text{ kg}$$

$$r_{SOI} = 227.9 \times 10^6 \left( \frac{6.419 \times 10^{23}}{1.989 \times 10^{30}} \right) = \underline{5.771 \times 10^5 \text{ km}}$$

Jupiter:

$$R = 778.6 \times 10^6 \text{ km}$$

$$m_p = 1.899 \times 10^{27} \text{ kg}$$

$$r_{SOI} = 778.6 \times 10^6 \left( \frac{1.899 \times 10^{27}}{1.989 \times 10^{30}} \right) = \underline{4.882 \times 10^7 \text{ km}}$$

### Problem 8.4

$$r_{SOI} = R \left( \frac{m_p}{m_{\text{sun}}} \right)$$

$$m_{\text{sun}} = 1.989 \times 10^{30} \text{ kg}$$

Saturn:

$$R = 1433 \times 10^6 \text{ km}$$

$$m_p = 5.685 \times 10^{26} \text{ kg}$$

$$r_{SOI} = 1433 \times 10^6 \left( \frac{5.685 \times 10^{26}}{1.989 \times 10^{30}} \right) = \underline{5.479 \times 10^7 \text{ km}}$$

Uranus:

$$R = 2872 \times 10^6 \text{ km}$$

$$m_p = 8.683 \times 10^{25} \text{ kg}$$

$$r_{SOI} = 2872 \times 10^6 \left( \frac{8.683 \times 10^{25}}{1.989 \times 10^{30}} \right) = \underline{5.178 \times 10^7 \text{ km}}$$

Neptune:

$$R = 4495 \times 10^6 \text{ km}$$

$$m_p = 1.024 \times 10^{26} \text{ kg}$$

$$r_{SOI} = 4495 \times 10^6 \left( \frac{1.024 \times 10^{26}}{1.989 \times 10^{30}} \right) = \underline{8.658 \times 10^7 \text{ km}}$$



Pluto:

$$R = 5870 \times 10^6 \text{ km}$$

$$m_p = 1.25 \times 10^{22} \text{ kg}$$

$$r_{SOI} = 5870 \times 10^6 \left( \frac{1.25 \times 10^{22}}{1.989 \times 10^{30}} \right) = \underline{3.076 \times 10^6 \text{ km}}$$

### Problem 8.5

$$\mu_{\text{sun}} = 132.7 \times 10^9 \text{ km}^3/\text{s}^2$$

$$\mu_{\text{Jupiter}} = 126.7 \times 10^6 \text{ km}^3/\text{s}^2$$

$$R_{\text{earth}} = 149.6 \times 10^6 \text{ km}$$

$$R_{\text{Jupiter}} = 778.6 \times 10^6 \text{ km}$$

$$r_{\text{Jupiter}} = 71490 \text{ km}$$

Semimajor axis of Hohmann transfer ellipse:

$$a_1 = \frac{1}{2} (R_{\text{earth}} + R_{\text{Jupiter}}) = \frac{1}{2} (149.6 \times 10^6 + 778.6 \times 10^6) = 464.1 \times 10^6 \text{ km}$$

$$V_{\text{Jupiter}} = \sqrt{\frac{\mu_{\text{sun}}}{R_{\text{Jupiter}}}} = \sqrt{\frac{132.7 \times 10^9}{778.6 \times 10^6}} = 13.06 \text{ km/s}$$

Use the energy equation to obtain the spacecraft's velocity upon arrival at Jupiter's sphere of influence:

$$V_1^{(v)} = \sqrt{\mu_{\text{sun}} \left( \frac{2}{R_{\text{Jupiter}}} - \frac{1}{a_1} \right)} = \sqrt{132.7 \times 10^9 \left( \frac{2}{778.6 \times 10^6} - \frac{1}{464.1 \times 10^6} \right)} = 7.412 \text{ km/s}$$

$$v_{\infty} = V_{\text{Jupiter}} - V_1^{(v)} = 13.06 - 7.412 = 5.643 \text{ km/s}$$

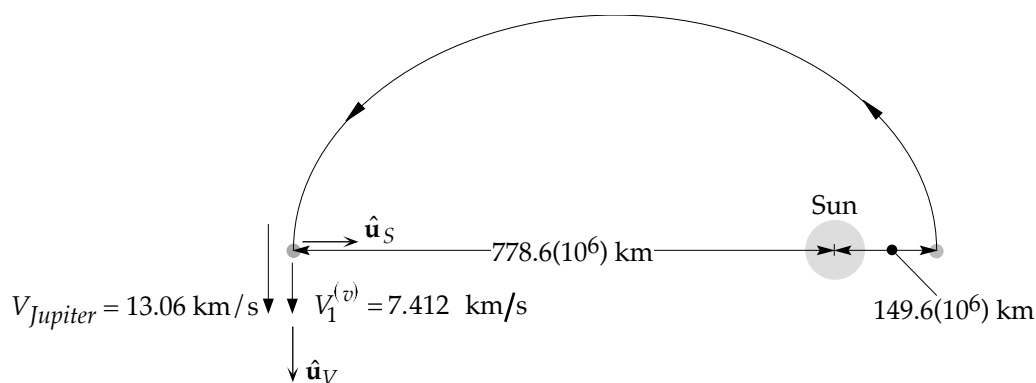

Eccentricity of hyperbolic swing by trajectory:

$$e = 1 + \frac{r_p v_{\infty}^2}{\mu_{\text{Jupiter}}} = 1 + \frac{271490 \cdot 5.643^2}{126.7 \times 10^6} = 1.068$$

Turn angle:

$$\delta = 2 \sin^{-1} \left( \frac{1}{e} \right) = 2 \sin^{-1} \left( \frac{1}{1.068} \right) = 138.8^\circ$$

Angle between  $\mathbf{V}_{\text{Jupiter}}$  and  $\mathbf{v}_{\infty}$  at inbound crossing:  $\phi_1 = 180^\circ$ . At the outbound crossing,

$$\phi_2 = 180^\circ + \delta = 318.8^\circ$$

At the outbound crossing

$$\begin{aligned} \mathbf{V}_2^{(v)} &= \mathbf{V}_{\text{Jupiter}} + \mathbf{v}_{\infty 2} \\ &= V_{\text{Jupiter}} \hat{\mathbf{u}}_V + (v_\infty \cos \phi_2 \hat{\mathbf{u}}_V + v_\infty \sin \phi_2) \hat{\mathbf{u}}_S \\ &= 13.06 \hat{\mathbf{u}}_V + (5.643 \cdot \cos 318.8^\circ \hat{\mathbf{u}}_V + 5.643 \sin 318.8^\circ) \hat{\mathbf{u}}_S \\ &= 17.30 \hat{\mathbf{u}}_V - 3.716 \hat{\mathbf{u}}_S \quad (\text{km/s}) \end{aligned}$$

$$\begin{aligned} \Delta \mathbf{V}^{(v)} &= \mathbf{V}_2^{(v)} - \mathbf{V}_1^{(v)} \\ &= (17.30 \hat{\mathbf{u}}_V - 3.716 \hat{\mathbf{u}}_S) - 7.412 \hat{\mathbf{u}}_V \\ &= 9.890 \hat{\mathbf{u}}_V - 3.716 \hat{\mathbf{u}}_S \quad (\text{km/s}) \end{aligned}$$

$$\therefore \Delta V^{(v)} = \|\Delta \mathbf{V}^{(v)}\| = \underline{10.57 \text{ km/s}}$$

$$\text{Alternatively, } \Delta V^{(v)} = 2v_\infty \sin \frac{\delta}{2} = 2 \cdot 5.643 \cdot \sin \frac{138.8^\circ}{2} = \underline{10.57 \text{ km/s.}}$$

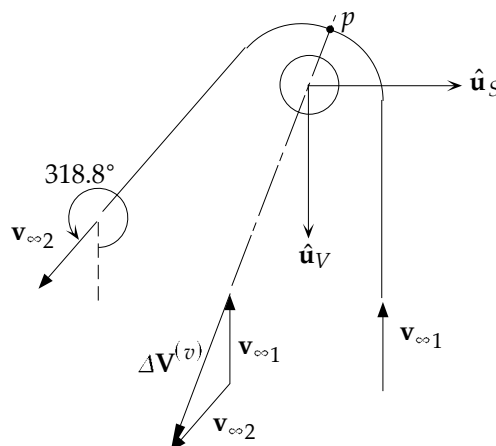

Angular momentum of the new orbit after flyby:

$$h_2 = R_{\text{Jupiter}} V_{\perp}^{(v)} = 778.6 \times 10^6 \cdot 17.30 = \underline{13.47 \times 10^9 \text{ km}^2/\text{s}}$$

Obtain the semimajor axis  $a_2$  from the energy equation:

$$\begin{aligned} \frac{V_2^{(v)2}}{2} - \frac{\mu_{\text{sun}}}{R_{\text{Jupiter}}} &= -\frac{\mu_{\text{sun}}}{2a_2} \\ \frac{17.70^2}{2} - \frac{132.7 \times 10^9}{778.6 \times 10^6} &= -\frac{132.7 \times 10^9}{2a_2} \Rightarrow \underline{a_2 = 4.791 \times 10^9 \text{ km}} \end{aligned}$$

Observe that  $a_2/a_1 = 10.32$ . The new orbit dwarfs the original one in size and, therefore, energy.

Use Equation 3.61 to find the eccentricity:

$$\begin{aligned} a_2 &= \frac{h_2^2}{\mu_{\text{sun}}} \frac{1}{1 - e_2^2} \\ 4.791 \times 10^9 &= \frac{13.47 \times 10^9^2}{132.7 \times 10^9} \frac{1}{1 - e_2^2} \Rightarrow \underline{e_2 = 0.8453} \end{aligned}$$

Use the orbit equation to find the true anomaly in the new orbit:

$$\begin{aligned} R_{\text{Jupiter}} &= \frac{h_2^2}{\mu_{\text{sun}}} \frac{1}{1 + e_2 \cos \theta_2} \\ 778.6 \times 10^6 &= \frac{13.47 \times 10^9^2}{132.7 \times 10^9} \frac{1}{1 + 0.8453 \cos \theta_2} \Rightarrow \underline{\theta_2 = 26.5^\circ} \end{aligned}$$

The new and original heliocentric orbits are illustrated below.

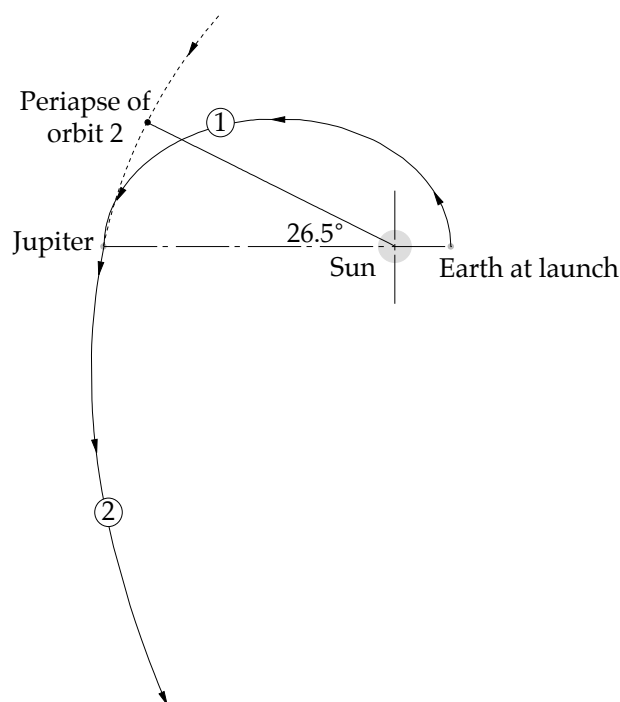

---

### Problem 8.6

Algorithm 8.1, which makes use of the data in Table 8.1, is implemented in MATLAB as the M-function `planet_elements_and_sv` in Appendix D.17. The MATLAB script `Example_8_07`, which also appears in Appendix D.17, calls upon `planet_elements_and_sv` to calculate the orbital elements of earth on the date specified in Example 8.7. The output to the Command Window is also listed in Appendix D.17 for comparison with the results presented in Example 8.7. By changing `planet_id` to 4, the following Command Window output is obtained for Mars.

-----  
 Problem 8.6

Input data:

```
Planet: Mars
Year   : 2003
Month  : August
Day    : 27
Hour   : 12
Minute : 0
Second : 0
```

```
Julian day: 2452879.000
```

Orbital elements:

```
Angular momentum (km^2/s)      = 5.47595e+09
Eccentricity                    = 0.0934167
Right ascension of the ascending node (deg) = 49.5682
Inclination to the ecliptic (deg) = 1.85035
Argument of perihelion (deg)    = 286.488
True anomaly (deg)              = 358.131
Semimajor axis (km)             = 2.27936e+08

Longitude of perihelion (deg)   = 336.057
Mean longitude (deg)            = 334.513
Mean anomaly (deg)              = 358.457
Eccentric anomaly (deg)         = 358.298
```

State vector:

Position vector (km) = [1.85954e+08 -8.99155e+07 -6.45661e+06]  
 Magnitude = 2.06653e+08

Velocity (km/s) = [11.4744 23.8842 0.218255]  
 Magnitude = 26.4984

**Problem 8.7** The following MATLAB script calls upon Algorithm 8.1, implemented as the MATLAB M-function `planet_elements_and_sv` in Appendix D.17, to compute the distance of the earth from the sun on the first day of each month of the year 2005, at 12:00:00 UT. The output to the MATLAB command window is listed afterwards.

```
% ~~~~~
% Problem_8_07a
% ~~~~~
%
% This program uses Algorithm 8.1 to compute the orbital elements
% and state vector of Mars at the date and time specified
% in Example 8.7.
%
% mu      - gravitational parameter of the sun (km^3/s^2)
%
% coe     - vector of heliocentric orbital elements
%           [h e RA incl w TA a w_hat L M E],
%           where
%           h      = angular momentum           (km^2/s)
%           e      = eccentricity
%           RA     = right ascension           (deg)
%           incl   = inclination               (deg)
%           w      = argument of perihelion    (deg)
%           TA     = true anomaly              (deg)
%           a      = semimajor axis            (km)
%           w_hat  = longitude of perihelion ( = RA + w) (deg)
%           L      = mean longitude ( = w_hat + M) (deg)
%           M      = mean anomaly              (deg)
%           E      = eccentric anomaly        (deg)
%
% r       - heliocentric position vector (km)
% v       - heliocentric velocity vector (km/s)
%
% planet_id - planet identifier:
%           1 = Mercury
%           2 = Venus
%           3 = Earth
%           4 = Mars
%           5 = Jupiter
%           6 = Saturn
%           7 = Uranus
%           8 = Neptune
%           9 = Pluto
%
% year    - range: 1901 - 2099
% month   - range: 1 - 12
% day     - range: 1 - 31
% hour    - range: 0 - 23
% minute  - range: 0 - 60
% second  - range: 0 - 60
%
% User M-functions required: planet_elements_and_sv,
%                           month_planet_names
```

```

% -----

global mu
mu = 1.327124e11;
deg = pi/180;

%...Data declaration for Problem 8.6 :
planet_id = 3;
year      = 2005;
day       = 1;
hour      = 12;
minute    = 0;
second    = 0;
%...

fprintf('\n-----\n')
fprintf(' Problem 8.7a: Determine the month\n')
fprintf('\n Year = %g   Time = 12:00:00 UT\n', year)

for month = 1:12
    %...Algorithm 8.1:
    [coe, r, v, jd] = planet_elements_and_sv ...
        (planet_id, year, month, day, hour, minute, second);
    %...Convert the month numbers into names for output:
    [month_name, planet_name] = month_planet_names(month, planet_id);
    fprintf('\n %10s 1st:   Distance = %11.5e (km)', month_name,
norm(r))
end
fprintf('\n-----\n')

-----
Problem 8.7a: Determine the month

Year = 2005   Time = 12:00:00 UT

January  1st:   Distance = 1.47100e+08 (km)
February 1st:   Distance = 1.47417e+08 (km)
March    1st:   Distance = 1.48243e+08 (km)
April    1st:   Distance = 1.49505e+08 (km)
May      1st:   Distance = 1.50745e+08 (km)
June     1st:   Distance = 1.51707e+08 (km)
July     1st:   Distance = 1.52093e+08 (km)
August   1st:   Distance = 1.51830e+08 (km)
September 1st:  Distance = 1.50963e+08 (km)
October  1st:   Distance = 1.49758e+08 (km)
November 1st:   Distance = 1.48464e+08 (km)
December 1st:   Distance = 1.47505e+08 (km)

-----

```

This list reveals that the greatest distance occurs in the month of July. We can modify the above MATLAB script to loop through the days of July:

```

% ~~~~~
% Problem_8_07b
% ~~~~~
%
% This program uses Algorithm 8.1 to determine the distance of the
% earth from the sun, according to Problem 8.7
%
% User M-functions required: planet_elements_and_sv,
%                             month_planet_names
% -----

```

```

global mu
mu = 1.327124e11;

%...Data declaration for Problem 8.7 :
planet_id = 3;
year      = 2005;
month     = 7;
hour      = 12;
minute    = 0;
second    = 0;
%...

fprintf('\n-----\n')
fprintf(' Problem 8.7b: Determine the day\n')
fprintf('\n Year = %g   Time = 12:00:00 UT\n', year)
%...Convert the planet_id and month numbers into names for output:
    [month_name, planet_name] = month_planet_names(month, planet_id);

for day = 1:31
    %...Algorithm 8.1:
    [coe, r, v, jd] = planet_elements_and_sv ...
        (planet_id, year, month, day, hour, minute, second);
    %...Convert the planet_id and month numbers into names for output:
    [month_name, planet_name] = month_planet_names(month, planet_id);
    fprintf('\n %5s %4g:   Distance = %14.7e (km)',...
        month_name, day, norm(r))
end
fprintf('\n-----\n')

```

The output to the MATLAB command window is:

```

-----
Problem 8.7b: Determine the day

Year = 2005   Time = 12:00:00 UT

July      1:   Distance = 1.5209314e+08 (km)
July      2:   Distance = 1.5209524e+08 (km)
July      3:   Distance = 1.5209664e+08 (km)
July      4:   Distance = 1.5209732e+08 (km)
July      5:   Distance = 1.5209728e+08 (km)
July      6:   Distance = 1.5209653e+08 (km)
July      7:   Distance = 1.5209506e+08 (km)
July      8:   Distance = 1.5209287e+08 (km)
July      9:   Distance = 1.5208998e+08 (km)
July     10:   Distance = 1.5208637e+08 (km)
July     11:   Distance = 1.5208204e+08 (km)
July     12:   Distance = 1.5207701e+08 (km)
July     13:   Distance = 1.5207126e+08 (km)
July     14:   Distance = 1.5206481e+08 (km)
July     15:   Distance = 1.5205765e+08 (km)
July     16:   Distance = 1.5204978e+08 (km)
July     17:   Distance = 1.5204122e+08 (km)
July     18:   Distance = 1.5203195e+08 (km)
July     19:   Distance = 1.5202198e+08 (km)
July     20:   Distance = 1.5201132e+08 (km)
July     21:   Distance = 1.5199996e+08 (km)
July     22:   Distance = 1.5198792e+08 (km)
July     23:   Distance = 1.5197519e+08 (km)
July     24:   Distance = 1.5196178e+08 (km)
July     25:   Distance = 1.5194769e+08 (km)
July     26:   Distance = 1.5193292e+08 (km)

```

```

July      27:   Distance = 1.5191748e+08 (km)
July      28:   Distance = 1.5190138e+08 (km)
July      29:   Distance = 1.5188461e+08 (km)
July      30:   Distance = 1.5186718e+08 (km)
July      31:   Distance = 1.5184910e+08 (km)
-----

```

The furthest distance occurs on July 4.

---

**Problem 8.8** For the data given in this problem, the following MATLAB script invokes Algorithm 8.2, which is implemented as the MATLAB M-function `interplanetary` in Appendix D.18. `interplanetary` uses Algorithms 8.1 and 5.2 to compute  $\mathbf{v}_\infty$  at the home and target planets. The output to the MATLAB Command Window is listed afterwards.

```

% ~~~~~
% Problem_8_08
% ~~~~~
%
% This program uses Algorithm 8.2 to obtain v-infinities
% in Problem 8.8.
%
% mu          - gravitational parameter of the sun (km^3/s^2)
% deg         - conversion factor between degrees and radians
% pi          - 3.1415926...
%
% planet_id  - planet identifier:
%              1 = Mercury
%              2 = Venus
%              3 = Earth
%              4 = Mars
%              5 = Jupiter
%              6 = Saturn
%              7 = Uranus
%              8 = Neptune
%              9 = Pluto
%
% year       - range: 1901 - 2099
% month      - range: 1 - 12
% day        - range: 1 - 31
% hour       - range: 0 - 23
% minute     - range: 0 - 60
% second     - range: 0 - 60
%
% depart     - [planet_id, year, month, day, hour, minute, second]
%              at departure
% arrive     - [planet_id, year, month, day, hour, minute, second]
%              at arrival
%
% planet1    - [Rp1, Vp1, jd1]
% planet2    - [Rp2, Vp2, jd2]
% trajectory - [V1, V2]
%
% coe        - orbital elements [h e RA incl w TA]
%              where
%              h   = angular momentum (km^2/s)
%              e   = eccentricity
%              RA  = right ascension of the ascending
%                   node (rad)
%              incl = inclination of the orbit (rad)
%              w   = argument of perigee (rad)
%              TA  = true anomaly (rad)

```

```

%           a      = semimajor axis (km)
%
% jd1, jd2      - Julian day numbers at departure and arrival
% tof           - time of flight from planet 1 to planet 2 (days)
%
% Rp1, Vp1     - state vector of planet 1 at departure (km, km/s)
% Rp2, Vp2     - state vector of planet 2 at arrival (km, km/s)
% R1, V1       - heliocentric state vector of spacecraft at
%               departure (km, km/s)
% R2, V2       - heliocentric state vector of spacecraft at
%               arrival (km, km/s)
%
% vinf1, vinf2 - hyperbolic excess velocities at departure
%               and arrival (km/s)
%
% User M-functions required: interplanetary, coe_from_sv,
%                             month_planet_names
% -----

clear
global mu
mu = 1.327124e11;
deg = pi/180;

%...Data declaration for Problem 8.8:

%...Departure
planet_id = 3;
year      = 2005;
month     = 12;
day       = 1;
hour      = 0;
minute    = 0;
second    = 0;
depart = [planet_id year month day hour minute second];

%...Arrival
planet_id = 2;
year      = 2006;
month     = 4;
day       = 1;
hour      = 0;
minute    = 0;
second    = 0;
arrive = [planet_id year month day hour minute second];

%...

%...Algorithm 8.2:
[planet1, planet2, trajectory] = interplanetary(depart, arrive);

R1 = planet1(1,1:3);
Vp1 = planet1(1,4:6);
jd1 = planet1(1,7);

R2 = planet2(1,1:3);
Vp2 = planet2(1,4:6);
jd2 = planet2(1,7);

V1 = trajectory(1,1:3);
V2 = trajectory(1,4:6);

tof = jd2 - jd1;

```



```

%...Use Algorithm 5.1 to find the orbital elements of the
% spacecraft trajectory based on [Rp1, V1]...
coe = coe_from_sv(R1, V1);
% ... and [R2, V2]
coe2 = coe_from_sv(R2, V2);

%...Equations 8.102 and 8.103:
vinf1 = V1 - Vp1;
vinf2 = V2 - Vp2;

%...Echo the input data and output the solution to
% the command window:
fprintf('-----')
fprintf('\n Problem 8.8: Earth to Venus')
fprintf('\n\n Departure:\n');
fprintf('\n Planet: %s', planet_name(depart(1)))
fprintf('\n Year : %g', depart(2))
fprintf('\n Month : %s', month_name(depart(3)))
fprintf('\n Day : %g', depart(4))
fprintf('\n Hour : %g', depart(5))
fprintf('\n Minute: %g', depart(6))
fprintf('\n Second: %g', depart(7))
fprintf('\n\n Julian day: %11.3f\n', jd1)
fprintf('\n Planet position vector (km) = [%g %g %g]', ...
        R1(1), R1(2), R1(3))

fprintf('\n Magnitude = %g\n', norm(R1))

fprintf('\n Planet velocity (km/s) = [%g %g %g]', ...
        Vp1(1), Vp1(2), Vp1(3))

fprintf('\n Magnitude = %g\n', norm(Vp1))

fprintf('\n Spacecraft velocity (km/s) = [%g %g %g]', ...
        V1(1), V1(2), V1(3))

fprintf('\n Magnitude = %g\n', norm(V1))

fprintf('\n v-infinity at departure (km/s) = [%g %g %g]', ...
        vinf1(1), vinf1(2), vinf1(3))

fprintf('\n Magnitude = %g\n', norm(vinf1))

fprintf('\n\n Time of flight = %g days\n', tof)

fprintf('\n\n Arrival:\n');
fprintf('\n Planet: %s', planet_name(arrive(1)))
fprintf('\n Year : %g', arrive(2))
fprintf('\n Month : %s', month_name(arrive(3)))
fprintf('\n Day : %g', arrive(4))
fprintf('\n Hour : %g', arrive(5))
fprintf('\n Minute: %g', arrive(6))
fprintf('\n Second: %g', arrive(7))
fprintf('\n\n Julian day: %11.3f\n', jd2)
fprintf('\n Planet position vector (km) = [%g %g %g]', ...
        R2(1), R2(2), R2(3))

fprintf('\n Magnitude = %g\n', norm(R2))

fprintf('\n Planet velocity (km/s) = [%g %g %g]', ...
        Vp2(1), Vp2(2), Vp2(3))

```

```

fprintf('\n Magnitude = %g\n', norm(Vp2))
fprintf('\n Spacecraft Velocity (km/s) = [%g %g %g]', ...
        V2(1), V2(2), V2(3))
fprintf('\n Magnitude = %g\n', norm(V2))
fprintf('\n v-infinity at arrival (km/s) = [%g %g %g]', ...
        vinf2(1), vinf2(2), vinf2(3))
fprintf('\n Magnitude = %g', norm(vinf2))
fprintf('\n\n\n Orbital elements of flight trajectory:\n')
fprintf('\n Angular momentum (km^2/s) = %g', ...
        coe(1))
fprintf('\n Eccentricity = %g', ...
        coe(2))
fprintf('\n Right ascension of the ascending node (deg) = %g', ...
        coe(3)/deg)
fprintf('\n Inclination to the ecliptic (deg) = %g', ...
        coe(4)/deg)
fprintf('\n Argument of perihelion (deg) = %g', ...
        coe(5)/deg)
fprintf('\n True anomaly at departure (deg) = %g', ...
        coe(6)/deg)
fprintf('\n True anomaly at arrival (deg) = %g\n', ...
        coe2(6)/deg)
fprintf('\n Semimajor axis (km) = %g', ...
        coe(7))
% If the orbit is an ellipse, output the period:
if coe(2) < 1
    fprintf('\n Period (days) = %g', ...
            2*pi/sqrt(mu)*coe(7)^1.5/24/3600)
end
fprintf('\n-----\n')

```

---

Problem 8.8: Earth to Venus

Departure:

```

Planet: Earth
Year : 2005
Month : December
Day : 1
Hour : 0
Minute: 0
Second: 0

```

Julian day: 2453705.500

```

Planet position vector (km) = [5.33243e+07  1.37541e+08  -1830.84]
Magnitude = 1.47517e+08

```

```

Planet velocity (km/s) = [-28.2595  10.6564  -6.01367e-05]
Magnitude = 30.202

```

```

Spacecraft velocity (km/s) = [-27.0436  6.58196  2.7931]
Magnitude = 27.9729

```

```

v-infinity at departure (km/s) = [1.2159  -4.07444  2.79316]

```

$$\text{Magnitude} = 5.08735$$

Time of flight = 121 days

Arrival:

Planet: Venus  
 Year : 2006  
 Month : April  
 Day : 1  
 Hour : 0  
 Minute: 0  
 Second: 0

Julian day: 2453826.500

Planet position vector (km) = [-5.74135e+07 -9.1938e+07 2.05581e+06]  
 Magnitude = 1.47517e+08

Planet velocity (km/s) = [29.4613 -18.7099 -1.95644]  
 Magnitude = 34.955

Spacecraft Velocity (km/s) = [30.3918 -22.2324 -3.68154]  
 Magnitude = 37.8351

v-infinity at arrival (km/s) = [0.930541 -3.52248 -1.7251]  
 Magnitude = 4.0311

Orbital elements of flight trajectory:

Angular momentum (km<sup>2</sup>/s) = 4.0914e+09  
 Eccentricity = 0.183291  
 Right ascension of the ascending node (deg) = 68.8159  
 Inclination to the ecliptic (deg) = 5.77973  
 Argument of perihelion (deg) = 142.255  
 True anomaly at departure (deg) = 217.738  
 True anomaly at arrival (deg) = 26.8913

Semimajor axis (km) = 1.30519e+08  
 Period (days) = 297.66

The output shows that at departure from earth,  $v_\infty = 5.087$  km/s. Hence, the spacecraft velocity at perigee of the departure hyperbola is

$$v_p = \sqrt{v_\infty^2 + \frac{2\mu_{\text{earth}}}{r_p}} = \sqrt{5.087^2 + \frac{2 \cdot 398600}{(6378 + 180)^2}} = 12.14 \text{ km/s}$$

The spacecraft velocity in its circular 180 km parking orbit is

$$v_c = \sqrt{\frac{\mu_{\text{earth}}}{r_p}} = \sqrt{\frac{398600}{6378 + 180}} = 7.796 \text{ km/s}$$

Hence, the delta-v requirement at earth is

$$\Delta v_1 = v_p - v_c = 12.14 - 7.796 = 4.346 \text{ km/s}$$

At Venus ( $\mu_{\text{Venus}} = 324\,900 \text{ km}^3/\text{s}^2$ ,  $r_{\text{Venus}} = 6052 \text{ km}$ ) the above output shows that  $v_\infty = 4.031 \text{ km/s}$ . The speed at the 300 km altitude periapse on the arrival hyperbola is therefore

$$v_{p_{\text{hyperbola}}} = \sqrt{v_\infty^2 + \frac{2\mu_{\text{Venus}}}{r_p^2}} = \sqrt{4.031^2 + \frac{2 \cdot 324\,900}{(6052 + 300)^2}} = 10.89 \text{ km/s}$$

The semimajor axis of the elliptical capture orbit is

$$a = \frac{1}{2} [(r_{\text{Venus}} + 300) + (r_{\text{Venus}} + 9000)] = 10702$$

Therefore the velocity at periapse on the ellipse is, using the energy equation,

$$v_{p_{\text{ellipse}}} = \sqrt{\mu_{\text{Venus}} \left( \frac{2}{r_p} - \frac{1}{a} \right)} = \sqrt{324\,900 \left( \frac{2}{6052 + 300} - \frac{1}{10702} \right)} = 8.482 \text{ km/s}$$

It follows that the delta-v requirement at Venus is

$$\Delta v_2 = v_{p_{\text{hyperbola}}} - v_{p_{\text{ellipse}}} = 10.89 - 8.482 = 2.406 \text{ km/s}$$

The total delta-v requirement is

$$\Delta v_{\text{total}} = \Delta v_1 + \Delta v_2 = 4.346 + 2.406 = \underline{\underline{6.753 \text{ km/s}}}$$

**Problem 8.9** For the data given in this problem, the following MATLAB script invokes Algorithm 8.2, which is implemented as the MATLAB M-function `interplanetary` in Appendix D.18. `interplanetary` uses Algorithms 8.1 and 5.2 to compute  $\mathbf{v}_\infty$  at the home and target planets. The output to the MATLAB Command Window is listed afterwards.

```

% ~~~~~
% Problem_8_09
% ~~~~~
%
% This program uses Algorithm 8.2 to obtain v-infinities
% in Problem 8.9.
%
% mu           - gravitational parameter of the sun (km^3/s^2)
% deg          - conversion factor between degrees and radians
% pi           - 3.1415926...
%
% planet_id    - planet identifier:
%                1 = Mercury
%                2 = Venus
%                3 = Earth
%                4 = Mars
%                5 = Jupiter
%                6 = Saturn
%                7 = Uranus
%                8 = Neptune
%                9 = Pluto
%
% year         - range: 1901 - 2099
% month        - range: 1 - 12
% day          - range: 1 - 31
% hour         - range: 0 - 23
% minute       - range: 0 - 60
% second       - range: 0 - 60

```

```

%
% depart      - [planet_id, year, month, day, hour, minute, second]
%              at departure
% arrive      - [planet_id, year, month, day, hour, minute, second]
%              at arrival
%
% planet1     - [Rp1, Vp1, jd1]
% planet2     - [Rp2, Vp2, jd2]
% trajectory  - [V1, V2]
%
% coe         - orbital elements [h e RA incl w TA]
%              where
%              h   = angular momentum (km^2/s)
%              e   = eccentricity
%              RA  = right ascension of the ascending
%                   node (rad)
%              incl = inclination of the orbit (rad)
%              w   = argument of perigee (rad)
%              TA  = true anomaly (rad)
%              a   = semimajor axis (km)
%
% jd1, jd2    - Julian day numbers at departure and arrival
% tof         - time of flight from planet 1 to planet 2 (days)
%
% Rp1, Vp1    - state vector of planet 1 at departure (km, km/s)
% Rp2, Vp2    - state vector of planet 2 at arrival (km, km/s)
% R1, V1      - heliocentric state vector of spacecraft at
%              departure (km, km/s)
% R2, V2      - heliocentric state vector of spacecraft at
%              arrival (km, km/s)
%
% vinf1, vinf2 - hyperbolic excess velocities at departure
%              and arrival (km/s)
%
% User M-functions required: interplanetary, coe_from_sv,
%                             month_planet_names
% -----

clear
global mu
mu = 1.327124e11;
deg = pi/180;

%...Data declaration for Problem 8.9:

%...Departure
planet_id = 3;
year      = 2005;
month     = 8;
day       = 15;
hour      = 0;
minute    = 0;
second    = 0;
depart = [planet_id year month day hour minute second];

%...Arrival
planet_id = 4;
year      = 2006;
month     = 3;
day       = 15;
hour      = 0;
minute    = 0;
second    = 0;

```

```

arrive = [planet_id year month day hour minute second];

%...

%...Algorithm 8.2:
[planet1, planet2, trajectory] = interplanetary(depart, arrive);

R1 = planet1(1,1:3);
Vp1 = planet1(1,4:6);
jd1 = planet1(1,7);

R2 = planet2(1,1:3);
Vp2 = planet2(1,4:6);
jd2 = planet2(1,7);

V1 = trajectory(1,1:3);
V2 = trajectory(1,4:6);

tof = jd2 - jd1;

%...Use Algorithm 5.1 to find the orbital elements of the
% spacecraft trajectory based on [Rp1, V1]...
coe = coe_from_sv(R1, V1);
% ... and [R2, V2]
coe2 = coe_from_sv(R2, V2);

%...Equations 8.102 and 8.103:
vinf1 = V1 - Vp1;
vinf2 = V2 - Vp2;

%...Echo the input data and output the solution to
% the command window:
fprintf('-----')
fprintf('\n Problem 8.9: Earth to Mars')
fprintf('\n\n Departure:\n');
fprintf('\n Planet: %s', planet_name(depart(1)))
fprintf('\n Year : %g', depart(2))
fprintf('\n Month : %s', month_name(depart(3)))
fprintf('\n Day : %g', depart(4))
fprintf('\n Hour : %g', depart(5))
fprintf('\n Minute: %g', depart(6))
fprintf('\n Second: %g', depart(7))
fprintf('\n\n Julian day: %11.3f\n', jd1)
fprintf('\n Planet position vector (km) = [%g %g %g]', ...
        R1(1), R1(2), R1(3))

fprintf('\n Magnitude = %g\n', norm(R1))

fprintf('\n Planet velocity (km/s) = [%g %g %g]', ...
        Vp1(1), Vp1(2), Vp1(3))

fprintf('\n Magnitude = %g\n', norm(Vp1))

fprintf('\n Spacecraft velocity (km/s) = [%g %g %g]', ...
        V1(1), V1(2), V1(3))

fprintf('\n Magnitude = %g\n', norm(V1))

fprintf('\n v-infinity at departure (km/s) = [%g %g %g]', ...
        vinf1(1), vinf1(2), vinf1(3))

fprintf('\n Magnitude = %g\n', norm(vinf1))

```

```

fprintf('\n\n Time of flight = %g days\n', tof)

fprintf('\n\n Arrival:\n');
fprintf('\n Planet: %s', planet_name(arrive(1)))
fprintf('\n Year : %g', arrive(2))
fprintf('\n Month : %s', month_name(arrive(3)))
fprintf('\n Day : %g', arrive(4))
fprintf('\n Hour : %g', arrive(5))
fprintf('\n Minute: %g', arrive(6))
fprintf('\n Second: %g', arrive(7))
fprintf('\n\n Julian day: %11.3f\n', jd2)
fprintf('\n Planet position vector (km) = [%g %g %g]', ...
        R2(1), R2(2), R2(3))

fprintf('\n Magnitude = %g\n', norm(R1))

fprintf('\n Planet velocity (km/s) = [%g %g %g]', ...
        Vp2(1), Vp2(2), Vp2(3))

fprintf('\n Magnitude = %g\n', norm(Vp2))

fprintf('\n Spacecraft Velocity (km/s) = [%g %g %g]', ...
        V2(1), V2(2), V2(3))

fprintf('\n Magnitude = %g\n', norm(V2))

fprintf('\n v-infinity at arrival (km/s) = [%g %g %g]', ...
        vinf2(1), vinf2(2), vinf2(3))

fprintf('\n Magnitude = %g', norm(vinf2))

fprintf('\n\n\n Orbital elements of flight trajectory:\n')

fprintf('\n Angular momentum (km^2/s) = %g', ...
        coe(1))
fprintf('\n Eccentricity = %g', ...
        coe(2))
fprintf('\n Right ascension of the ascending node (deg) = %g', ...
        coe(3)/deg)
fprintf('\n Inclination to the ecliptic (deg) = %g', ...
        coe(4)/deg)
fprintf('\n Argument of perihelion (deg) = %g', ...
        coe(5)/deg)
fprintf('\n True anomaly at departure (deg) = %g', ...
        coe(6)/deg)
fprintf('\n True anomaly at arrival (deg) = %g\n', ...
        coe2(6)/deg)
fprintf('\n Semimajor axis (km) = %g', ...
        coe(7))

% If the orbit is an ellipse, output the period:
if coe(2) < 1
    fprintf('\n Period (days) = %g', ...
            2*pi/sqrt(mu)*coe(7)^1.5/24/3600)
end

fprintf('\n-----\n')

-----
Problem 8.9: Earth to Mars

Departure:

Planet: Earth

```

Year : 2005  
 Month : August  
 Day : 15  
 Hour : 0  
 Minute: 0  
 Second: 0

Julian day: 2453597.500

Planet position vector (km) = [1.19728e+08 -9.28572e+07 798.533]  
 Magnitude = 1.51517e+08

Planet velocity (km/s) = [17.7711 23.4274 -0.000315884]  
 Magnitude = 29.405

Spacecraft velocity (km/s) = [20.6107 25.7677 1.75181]  
 Magnitude = 33.0431

v-infinity at departure (km/s) = [2.83967 2.34021 1.75212]  
 Magnitude = 4.07557

Time of flight = 212 days

Arrival:

Planet: Mars  
 Year : 2006  
 Month : March  
 Day : 15  
 Hour : 0  
 Minute: 0  
 Second: 0

Julian day: 2453809.500

Planet position vector (km) = [-8.33472e+07 2.26736e+08 6.79991e+06]  
 Magnitude = 1.51517e+08

Planet velocity (km/s) = [-21.8221 -6.30169 0.40447]  
 Magnitude = 22.7173

Spacecraft Velocity (km/s) = [-20.4825 -4.25753 -0.845206]  
 Magnitude = 20.9374

v-infinity at arrival (km/s) = [1.33959 2.04416 -1.24968]  
 Magnitude = 2.74496

Orbital elements of flight trajectory:

Angular momentum (km<sup>2</sup>/s) = 5.00602e+09  
 Eccentricity = 0.246978  
 Right ascension of the ascending node (deg) = 322.198  
 Inclination to the ecliptic (deg) = 3.03935  
 Argument of perihelion (deg) = 355.671  
 True anomaly at departure (deg) = 4.33479  
 True anomaly at arrival (deg) = 152.278  
 Semimajor axis (km) = 2.01098e+08  
 Period (days) = 569.273

-----



The output shows that at departure from earth,  $v_\infty = 4.076$  km/s. Hence, the spacecraft velocity at perigee of the departure hyperbola is

$$v_p = \sqrt{v_\infty^2 + \frac{2\mu_{\text{earth}}}{r_p^2}} = \sqrt{4.076^2 + \frac{2 \cdot 398\,600}{(6378 + 190)^2}} = 11.75 \text{ km/s}$$

The spacecraft velocity in its circular 190 km parking orbit is

$$v_c = \sqrt{\frac{\mu_{\text{earth}}}{r_p}} = \sqrt{\frac{398\,600}{6378 + 190}} = 7.790 \text{ km/s}$$

Hence, the delta-v requirement at earth is

$$\Delta v_1 = v_p - v_c = 11.75 - 7.790 = 3.957 \text{ km/s}$$

At Mars ( $\mu_{\text{Mars}} = 42\,830 \text{ km}^3/\text{s}^2$ ,  $r_{\text{Mars}} = 3396 \text{ km}$ ) the above output shows that  $v_\infty = 2.745$  km/s. The speed at the 300 km altitude periapse on the arrival hyperbola is therefore

$$v_{p_{\text{hyperbola}}} = \sqrt{v_\infty^2 + \frac{2\mu_{\text{Mars}}}{r_p^2}} = \sqrt{2.745^2 + \frac{2 \cdot 42\,830}{(3396 + 300)^2}} = 5.542 \text{ km/s}$$

The semimajor axis of the capture ellipse is found from the required 35 hour period.

$$T = \frac{2\pi}{\sqrt{\mu_{\text{Mars}}}} a^{3/2}$$

$$35 \cdot 3600 = \frac{2\pi}{\sqrt{42\,830}} a^{3/2} \Rightarrow a = 25\,830 \text{ km}$$

Therefore the velocity at periapse on the ellipse is, using the energy equation,

$$v_{p_{\text{ellipse}}} = \sqrt{\mu_{\text{Mars}} \left( \frac{2}{r_p} - \frac{1}{a} \right)} = \sqrt{42\,830 \left( \frac{2}{3396 + 300} - \frac{1}{25\,830} \right)} = 4.639 \text{ km/s}$$

It follows that the delta-v requirement at Mars is

$$\Delta v_2 = v_{p_{\text{hyperbola}}} - v_{p_{\text{ellipse}}} = 5.542 - 4.639 = 0.9030 \text{ km/s}$$

The total delta-v requirement is

$$\Delta v_{\text{total}} = \Delta v_1 + \Delta v_2 = 3.957 + 0.9030 = \underline{4.860 \text{ km/s}}$$

### Problem 8.10

$$R_{\text{earth}} = 149.6 \times 10^6 \text{ km} \quad R_{\text{Saturn}} = 1433 \times 10^6 \text{ km}$$

Semimajor axis of Hohmann transfer ellipse:

$$a = \frac{1}{2} (R_{\text{earth}} + R_{\text{Saturn}}) = \frac{1}{2} (149.6 \times 10^6 + 1433 \times 10^6) = 791.3 \times 10^6 \text{ km}$$

Period of Hohmann transfer ellipse:

$$T = \frac{2\pi}{\sqrt{\mu_{\text{sun}}}} a^{3/2} = \frac{2\pi}{\sqrt{132.7 \times 10^9}} (791.3 \times 10^6)^{3/2} = 383.9 \times 10^6 \text{ s} = 12.17 \text{ y}$$

Therefore, the time of flight to Saturn's orbit is  $T/2 = 6.083 \text{ y}$ . Cassini departed on 15 October 1997 (Julian day 2 450 736.5) and arrived on 1 July 2004 (Julian day 2 453 187.5). The number of years for Cassini's flight was

$$\frac{2\,453\,187.5 - 2\,450\,736.5}{365.25} = 6.71 \text{ y}$$

Cassini, with its several flyby maneuvers, required a flight time only about 10 percent longer than the Hohmann transfer.

The velocity of the spacecraft at the outbound crossing of the earth's sphere of influence is

$$V^{(v)} = \sqrt{\mu_{\text{sun}} \left( \frac{2}{R_{\text{earth}}} - \frac{1}{a} \right)} = \sqrt{132.7 \times 10^9 \left( \frac{2}{149.6 \times 10^6} - \frac{1}{791.3 \times 10^6} \right)} = 40.08 \text{ km/s}$$

The velocity of earth in its (assumed) circular orbit is

$$V_{\text{earth}} = \sqrt{\frac{\mu_{\text{sun}}}{R_{\text{earth}}}} = \sqrt{\frac{132.7 \times 10^9}{149.6 \times 10^6}} = 29.78 \text{ km/s}$$

Thus

$$v_{\infty} = V^{(v)} - V_{\text{earth}} = 40.08 - 29.78 = 10.3 \text{ km/s}$$

The spacecraft velocity at the 180 km altitude perigee of the departure hyperbola is

$$v_p = \sqrt{v_{\infty}^2 + \frac{2\mu_{\text{earth}}}{r_p}} = \sqrt{10.3^2 + \frac{2 \cdot 398\,600}{6378 + 180}} = 15.09 \text{ km/s}$$

The velocity in the circular parking orbit is

$$v_c = \sqrt{\frac{\mu_{\text{earth}}}{r_p}} = \sqrt{\frac{398\,600}{6378 + 180}} = 7.796 \text{ km/s}$$

Hence,

$$\Delta v = v_p - v_c = 15.09 - 7.796 = 7.289 \text{ km/s}$$

From Equation 6.1

$$\Delta m = m_o \left[ 1 - \exp\left(-\frac{\Delta v}{I_{sp} g_o}\right) \right] = m_o \left[ 1 - \exp\left(-\frac{7.289}{300 \cdot 9.81 \times 10^{-3}}\right) \right] = 0.916 m_o$$

But  $\Delta m$  equals the mass  $m_p$  of propellant expended, and the initial mass  $m_o$  equals  $m_p$  plus the mass of the spacecraft (2000 kg). Thus,

$$m_p = 0.916(2000 + m_p) \Rightarrow \underline{m_p = 21810 \text{ kg}}$$



**Problem 9.1**

Method 1: Use  $(\hat{\mathbf{I}}, \hat{\mathbf{J}}, \hat{\mathbf{K}})$  as the basis.

$$\hat{\mathbf{i}} = \sin \theta \sin \phi \hat{\mathbf{I}} - \sin \theta \cos \phi \hat{\mathbf{J}} + \cos \theta \hat{\mathbf{K}} \quad (1)$$

$$\hat{\mathbf{j}} = \cos \phi \hat{\mathbf{I}} + \sin \phi \hat{\mathbf{J}} \quad (2)$$

$$\hat{\mathbf{k}} = -\cos \theta \sin \phi \hat{\mathbf{I}} + \cos \theta \cos \phi \hat{\mathbf{J}} + \sin \theta \hat{\mathbf{K}} \quad (3)$$

$$\boldsymbol{\omega} = 2\hat{\mathbf{K}} + 3\hat{\mathbf{j}} + 4\hat{\mathbf{i}} \quad (4)$$

$$\boldsymbol{\alpha} = \dot{\boldsymbol{\omega}} = 3\dot{\hat{\mathbf{j}}} + 4\dot{\hat{\mathbf{i}}}$$

$$\dot{\hat{\mathbf{j}}} = (2\hat{\mathbf{K}}) \times \hat{\mathbf{j}} = (2\hat{\mathbf{K}}) \times (\cos \phi \hat{\mathbf{I}} + \sin \phi \hat{\mathbf{J}}) = -2 \sin \phi \hat{\mathbf{I}} + 2 \cos \phi \hat{\mathbf{J}}$$

$$\begin{aligned} \dot{\hat{\mathbf{i}}} &= (2\hat{\mathbf{K}} + 3\hat{\mathbf{j}}) \times \hat{\mathbf{i}} = (2\hat{\mathbf{K}} + 3 \cos \phi \hat{\mathbf{I}} + 3 \sin \phi \hat{\mathbf{J}}) \times (\sin \theta \sin \phi \hat{\mathbf{I}} - \sin \theta \cos \phi \hat{\mathbf{J}} + \cos \theta \hat{\mathbf{K}}) \\ &= (3 \cos \theta \sin \phi + 2 \sin \theta \cos \phi) \hat{\mathbf{I}} + (2 \sin \theta \sin \phi - 3 \cos \theta \cos \phi) \hat{\mathbf{J}} - 3 \sin \theta \hat{\mathbf{K}} \end{aligned}$$

$$\begin{aligned} \boldsymbol{\alpha} &= 3(-2 \sin \phi \hat{\mathbf{I}} + 2 \cos \phi \hat{\mathbf{J}}) + 4[(3 \cos \theta \sin \phi + 2 \sin \theta \cos \phi) \hat{\mathbf{I}} + (2 \sin \theta \sin \phi - 3 \cos \theta \cos \phi) \hat{\mathbf{J}} - 3 \sin \theta \hat{\mathbf{K}}] \\ &= (-6 \sin \phi + 12 \cos \theta \sin \phi + 8 \sin \theta \cos \phi) \hat{\mathbf{I}} + (6 \cos \phi - 12 \cos \theta \cos \phi + 8 \sin \theta \sin \phi) \hat{\mathbf{J}} - 12 \sin \theta \hat{\mathbf{K}} \end{aligned}$$

$$\begin{aligned} \alpha &= \sqrt{\boldsymbol{\alpha} \cdot \boldsymbol{\alpha}} \\ &= \sqrt{(-6 \sin \phi + 12 \cos \theta \sin \phi + 8 \sin \theta \cos \phi)^2 + (6 \cos \phi - 12 \cos \theta \cos \phi + 8 \sin \theta \sin \phi)^2 + 144 \sin^2 \theta} \\ &= \sqrt{(\sin^2 \phi + \cos^2 \phi)(36 + 144 \cos^2 \theta - 144 \cos \theta + 64 \sin^2 \theta) + 144 \sin^2 \theta} \\ &= \sqrt{36 + 144(\cos^2 \theta + \sin^2 \theta) - 144 \cos \theta + 64 \sin^2 \theta} \\ &= \sqrt{36 + 144 - 144 \cos \theta + 64 \sin^2 \theta} \end{aligned}$$

$$\alpha = \sqrt{180 - 144 \cos \theta + 64 \sin^2 \theta}$$

Method 2: Use  $(\hat{\mathbf{i}}, \hat{\mathbf{j}}, \hat{\mathbf{k}})$  as the basis. Multiply (1) through by  $\cos \theta$  and (2) by  $\sin \theta$  to obtain

$$\begin{aligned} \sin \theta \cos \theta \sin \phi \hat{\mathbf{I}} - \sin \theta \cos \theta \cos \phi \hat{\mathbf{J}} + \cos^2 \theta \hat{\mathbf{K}} &= \cos \theta \hat{\mathbf{i}} \\ -\sin \theta \cos \theta \sin \phi \hat{\mathbf{I}} + \sin \theta \cos \theta \cos \phi \hat{\mathbf{J}} + \sin^2 \theta \hat{\mathbf{K}} &= \sin \theta \hat{\mathbf{k}} \end{aligned}$$

Adding these two equations yields

$$\hat{\mathbf{K}} = \cos \theta \hat{\mathbf{i}} + \sin \theta \hat{\mathbf{k}}$$

Then (4) can be written

$$\boldsymbol{\omega} = 2(\cos \theta \hat{\mathbf{i}} + \sin \theta \hat{\mathbf{k}}) + 3\hat{\mathbf{j}} + 4\hat{\mathbf{i}} = (4 + 2 \cos \theta) \hat{\mathbf{i}} + 3\hat{\mathbf{j}} + 2 \sin \theta \hat{\mathbf{k}} \quad (6)$$

$$\boldsymbol{\alpha} = \left. \frac{d\boldsymbol{\omega}}{dt} \right|_{rel} + \boldsymbol{\Omega} \times \boldsymbol{\omega}$$

$$\left. \frac{d\boldsymbol{\omega}}{dt} \right|_{rel} = -2\dot{\theta} \sin \theta \hat{\mathbf{i}} + 2\dot{\theta} \cos \theta \hat{\mathbf{k}} = -6 \sin \theta \hat{\mathbf{i}} + 6 \cos \theta \hat{\mathbf{k}}$$

$$\boldsymbol{\Omega} = 2\hat{\mathbf{K}} + 3\hat{\mathbf{j}} = 2(\cos\theta\hat{\mathbf{i}} + \sin\theta\hat{\mathbf{k}}) + 3\hat{\mathbf{j}}$$

$$\boldsymbol{\Omega} \times \boldsymbol{\omega} = \begin{vmatrix} \hat{\mathbf{i}} & \hat{\mathbf{j}} & \hat{\mathbf{k}} \\ 2\cos\theta & 3 & 2\sin\theta \\ 4 + 2\cos\theta & 3 & \sin\theta \end{vmatrix} = 8\sin\theta\hat{\mathbf{j}} - 12\hat{\mathbf{k}}$$

$$\therefore \boldsymbol{\alpha} = (-6\sin\theta\hat{\mathbf{i}} + 6\cos\theta\hat{\mathbf{k}}) + 8\sin\theta\hat{\mathbf{j}} - 12\hat{\mathbf{k}} = -6\sin\theta\hat{\mathbf{i}} + 8\sin\theta\hat{\mathbf{j}} + (6\cos\theta - 12)\hat{\mathbf{k}}$$

$$\begin{aligned} \alpha &= \sqrt{\boldsymbol{\alpha} \cdot \boldsymbol{\alpha}} = \sqrt{36\sin^2\theta + 64\sin^2\theta + (36\cos^2\theta - 144\cos\theta + 144)} \\ &= \sqrt{36(\sin^2\theta + \cos^2\theta) + 64\sin^2\theta - 144\cos\theta + 144} \\ &= \sqrt{36 + 64\sin^2\theta - 144\cos\theta + 144} \end{aligned}$$

$$\alpha = \sqrt{180 + 64\sin^2\theta - 144\cos\theta}$$

### Problem 9.2

(a)

$$\boldsymbol{\omega}_{\text{plate}} = \left\{ [(\dot{\theta}\hat{\mathbf{k}}) + \dot{\phi}\hat{\mathbf{j}}] + \dot{\nu}\hat{\mathbf{m}} \right\} + \psi\hat{\mathbf{n}} \quad (1)$$

$$\hat{\mathbf{m}} = \sin\phi\hat{\mathbf{i}} + \cos\phi\hat{\mathbf{k}} \quad \hat{\mathbf{p}} = \hat{\mathbf{m}} \times \hat{\mathbf{j}} = -\cos\phi\hat{\mathbf{i}} + \sin\phi\hat{\mathbf{k}}$$

$$\hat{\mathbf{n}} = \cos\nu\hat{\mathbf{j}} + \sin\nu\hat{\mathbf{p}} = -\cos\phi\sin\nu\hat{\mathbf{i}} + \cos\nu\hat{\mathbf{j}} + \sin\phi\sin\nu\hat{\mathbf{k}}$$

Substituting  $\hat{\mathbf{m}}$  and  $\hat{\mathbf{n}}$  into (1) yields the result,

$$\boldsymbol{\omega}_{\text{plate}} = (\dot{\nu}\sin\phi - \psi\cos\phi\sin\nu)\hat{\mathbf{i}} + (\dot{\phi} + \psi\cos\nu)\hat{\mathbf{j}} + (\dot{\theta} + \dot{\nu}\cos\phi + \psi\sin\phi\sin\nu)\hat{\mathbf{k}} \quad (2)$$

(b)

$$\boldsymbol{\alpha}_{\text{plate}} = \left. \frac{d\boldsymbol{\omega}_{\text{plate}}}{dt} \right|_{\text{rel}} = \left. \frac{d\boldsymbol{\omega}_{\text{plate}}}{dt} \right|_{\text{rel}} + \boldsymbol{\Omega} \times \boldsymbol{\omega}_{\text{plate}} \quad (3)$$

where  $\boldsymbol{\Omega}$  is the angular velocity of the  $xyz$  frame, which is  $\dot{\theta}\hat{\mathbf{k}}$ . That is,

$$\boldsymbol{\Omega} = \dot{\theta}\hat{\mathbf{k}} \quad (4)$$

From (2)

$$\left. \frac{d\boldsymbol{\omega}_{\text{plate}}}{dt} \right|_{\text{rel}} = \left[ \frac{d}{dt}(\dot{\nu}\sin\phi - \psi\cos\phi\sin\nu) \right] \hat{\mathbf{i}} + \left[ \frac{d}{dt}(\dot{\phi} + \psi\cos\nu) \right] \hat{\mathbf{j}} + \left[ \frac{d}{dt}(\dot{\theta} + \dot{\nu}\cos\phi + \psi\sin\phi\sin\nu) \right] \hat{\mathbf{k}}$$

Taking the derivatives, bearing in mind that  $\dot{\theta}$ ,  $\dot{\phi}$  and  $\dot{\psi}$  are all constant, we get

$$\begin{aligned} \left. \frac{d\boldsymbol{\omega}_{\text{plate}}}{dt} \right|_{\text{rel}} &= [\dot{\phi}(\dot{\nu}\cos\phi + \psi\sin\phi\sin\nu) - \psi\dot{\nu}\cos\phi\cos\nu] \hat{\mathbf{i}} \\ &\quad - \psi\dot{\nu}\sin\nu\hat{\mathbf{j}} + [\dot{\phi}(-\dot{\nu}\sin\phi + \psi\cos\phi\sin\nu) + \psi\dot{\nu}\cos\nu\sin\phi] \hat{\mathbf{k}} \end{aligned} \quad (5)$$

From (2) and (4),

$$\begin{aligned}\boldsymbol{\Omega} \times \boldsymbol{\omega}_{\text{plate}} &= \dot{\theta} \hat{\mathbf{k}} \times \left[ (\dot{\nu} \sin \phi - \dot{\psi} \cos \phi \sin \nu) \hat{\mathbf{i}} \right. \\ &\quad \left. + (\dot{\phi} + \dot{\psi} \cos \nu) \hat{\mathbf{j}} + (\dot{\theta} + \dot{\nu} \cos \phi + \dot{\psi} \sin \phi \sin \nu) \hat{\mathbf{k}} \right] \\ &= -\dot{\theta} (\dot{\psi} \cos \nu + \dot{\phi}) \hat{\mathbf{i}} + \dot{\theta} (\dot{\nu} \sin \phi - \dot{\psi} \cos \phi \sin \nu) \hat{\mathbf{j}}\end{aligned}\quad (6)$$

Substituting (5) and (6) into (3) and collecting terms yields the result,

$$\begin{aligned}\boldsymbol{\alpha}_{\text{plate}} &= \left[ \dot{\nu} (\dot{\phi} \cos \phi - \dot{\psi} \cos \phi \cos \nu) + \dot{\psi} \dot{\phi} \sin \phi \sin \nu - \dot{\psi} \dot{\theta} \cos \nu - \dot{\phi} \dot{\theta} \right] \hat{\mathbf{i}} \\ &\quad + \left[ \dot{\nu} (\dot{\theta} \sin \phi - \dot{\psi} \sin \nu) - \dot{\psi} \dot{\theta} \cos \phi \sin \nu \right] \hat{\mathbf{j}} \\ &\quad + \left[ \dot{\psi} \dot{\nu} \cos \nu \sin \phi + \dot{\psi} \dot{\phi} \cos \phi \sin \nu - \dot{\phi} \dot{\nu} \sin \phi \right] \hat{\mathbf{k}}\end{aligned}\quad (7)$$

(c)

$$\mathbf{a}_C = \mathbf{a}_B + \boldsymbol{\alpha}_{BC} \times \mathbf{r}_{C/B} + \boldsymbol{\omega}_{BC} \times (\boldsymbol{\omega}_{BC} \times \mathbf{r}_{C/B}) \quad (8)$$

$$\mathbf{r}_{C/B} = l \hat{\mathbf{m}} = l \sin \phi \hat{\mathbf{i}} + \cos \gamma \hat{\mathbf{k}} \quad (9)$$

$$\boldsymbol{\omega}_{BC} = \dot{\theta} \hat{\mathbf{k}} + \dot{\phi} \hat{\mathbf{j}} \quad (10)$$

$$\boldsymbol{\alpha}_{BC} = \left. \frac{d\boldsymbol{\omega}_{BC}}{dt} \right|_{rel} = \left. \frac{d\boldsymbol{\omega}_{BC}}{dt} \right|_{rel} + \boldsymbol{\Omega} \times \boldsymbol{\omega}_{BC} = \mathbf{0} + \dot{\theta} \hat{\mathbf{k}} \times (\dot{\theta} \hat{\mathbf{k}} + \dot{\phi} \hat{\mathbf{j}}) = -\dot{\theta} \dot{\phi} \hat{\mathbf{i}} \quad (11)$$

$$\begin{aligned}\mathbf{a}_B &= \mathbf{a}_O + \boldsymbol{\alpha}_{AB} \times \mathbf{r}_{B/O} + \boldsymbol{\omega}_{AB} \times (\boldsymbol{\omega}_{AB} \times \mathbf{r}_{B/O}) \\ &= \mathbf{0} + \mathbf{0} \times (1.25l \hat{\mathbf{j}}) + \dot{\theta} \hat{\mathbf{k}} \times (\dot{\theta} \hat{\mathbf{k}} \times 1.25l \hat{\mathbf{j}}) = -1.25\dot{\theta}^2 l \hat{\mathbf{j}}\end{aligned}\quad (12)$$

Substituting (9), (10), (11) and (12) into (8) yields

$$\mathbf{a}_C = \left( -1.25\dot{\theta}^2 l \hat{\mathbf{j}} \right) + \left( -\dot{\theta} \dot{\phi} \hat{\mathbf{i}} \right) \times \left( l \sin \phi \hat{\mathbf{i}} + \cos \gamma \hat{\mathbf{k}} \right) + \left( \dot{\theta} \hat{\mathbf{k}} + \dot{\phi} \hat{\mathbf{j}} \right) \times \left[ \left( \dot{\theta} \hat{\mathbf{k}} + \dot{\phi} \hat{\mathbf{j}} \right) \times \left( l \sin \phi \hat{\mathbf{i}} + \cos \gamma \hat{\mathbf{k}} \right) \right]$$

Upon expanding and collecting terms, we get the result

$$\mathbf{a}_C = -l \left( \dot{\phi}^2 + \dot{\theta}^2 \right) \sin \phi \hat{\mathbf{i}} + \left( 2l \dot{\phi} \dot{\theta} \cos \phi - 1.25l \dot{\theta}^2 \right) \hat{\mathbf{j}} - l \dot{\phi}^2 \cos \phi \hat{\mathbf{k}}$$

### Problem 9.3

$$\begin{aligned}\mathbf{a}_G &= \left. \frac{d\mathbf{v}}{dt} \right|_{rel} + \boldsymbol{\omega} \times \mathbf{v} \\ &= \frac{d}{dt} \left( t^3 \hat{\mathbf{i}} + 4 \hat{\mathbf{j}} \right) + \left( 2t^2 \hat{\mathbf{k}} \right) \times \left( t^3 \hat{\mathbf{i}} + 4 \hat{\mathbf{j}} \right) \\ &= 3t^2 \hat{\mathbf{i}} + \left( -8t^2 \hat{\mathbf{i}} + 2t^5 \hat{\mathbf{j}} \right) \\ &= -5t^2 \hat{\mathbf{i}} + 2t^5 \hat{\mathbf{j}}\end{aligned}$$

At  $t = 2$  s

$$\mathbf{a}_G = -20 \hat{\mathbf{i}} + 64 \hat{\mathbf{j}} \text{ (m}^2/\text{s)}$$

### Problem 9.4

$$\begin{aligned}\boldsymbol{\alpha} &= \left. \frac{d\boldsymbol{\omega}}{dt} \right|_{rel} + \boldsymbol{\Omega} \times \boldsymbol{\omega} \\ \boldsymbol{\alpha} &= \frac{d}{dt} \left( \omega_x \hat{\mathbf{i}} + \omega_y \hat{\mathbf{j}} + \omega_z \hat{\mathbf{k}} \right) + \left( \omega_x \hat{\mathbf{i}} + \omega_y \hat{\mathbf{j}} \right) \times \left( \omega_x \hat{\mathbf{i}} + \omega_y \hat{\mathbf{j}} + \omega_z \hat{\mathbf{k}} \right)\end{aligned}$$

$$\boldsymbol{\alpha} = 0 + \begin{vmatrix} \hat{\mathbf{i}} & \hat{\mathbf{j}} & \hat{\mathbf{k}} \\ \omega_x & \omega_y & 0 \\ \omega_x & \omega_y & \omega_z \end{vmatrix}$$

$$\boldsymbol{\alpha} = \omega_y \omega_z \hat{\mathbf{i}} - \omega_x \omega_z \hat{\mathbf{j}}$$

### Problem 9.5

About the origin  $O$ :

$$[\mathbf{I}_i] = m_i \begin{bmatrix} y_i^2 + z_i^2 & -x_i y_i & -x_i z_i \\ -x_i y_i & x_i^2 + z_i^2 & -y_i z_i \\ -x_i z_i & -y_i z_i & x_i^2 + y_i^2 \end{bmatrix}$$

$$[\mathbf{I}_1] = \begin{bmatrix} 20 & -10 & -10 \\ -10 & 20 & -10 \\ -10 & -10 & 20 \end{bmatrix} (\text{kg} \cdot \text{m}^2) \quad [\mathbf{I}_2] = \begin{bmatrix} 20 & -10 & -10 \\ -10 & 20 & -10 \\ -10 & -10 & 20 \end{bmatrix} (\text{kg} \cdot \text{m}^2)$$

$$[\mathbf{I}_3] = \begin{bmatrix} 256 & 128 & -128 \\ 128 & 256 & 128 \\ -128 & 128 & 256 \end{bmatrix} (\text{kg} \cdot \text{m}^2) \quad [\mathbf{I}_4] = \begin{bmatrix} 64 & 32 & -32 \\ 32 & 64 & 32 \\ -32 & 32 & 64 \end{bmatrix} (\text{kg} \cdot \text{m}^2)$$

$$[\mathbf{I}_5] = \begin{bmatrix} 216 & 108 & 108 \\ 108 & 216 & -108 \\ 108 & -108 & 216 \end{bmatrix} (\text{kg} \cdot \text{m}^2) \quad [\mathbf{I}_6] = \begin{bmatrix} 216 & 108 & 108 \\ 108 & 216 & -108 \\ 108 & -108 & 216 \end{bmatrix} (\text{kg} \cdot \text{m}^2)$$

$$[\mathbf{I}_O] = \sum_{i=1}^6 [\mathbf{I}_i] = \begin{bmatrix} 792 & 356 & 36 \\ 356 & 792 & -76 \\ 36 & -76 & 792 \end{bmatrix} (\text{kg} \cdot \text{m}^2)$$

$$m = \sum_{i=1}^6 m_i = 60 \text{ kg}$$

$$x_G = \frac{\sum_{i=1}^6 m_i x_i}{m} = \frac{16}{60} = 0.2667 \text{ m}$$

$$y_G = \frac{\sum_{i=1}^6 m_i y_i}{m} = \frac{-16}{60} = -0.2667 \text{ m}$$

$$z_G = \frac{\sum_{i=1}^6 m_i z_i}{m} = \frac{16}{60} = 0.2667 \text{ m}$$

$$[\mathbf{I}_{mP}] = m \begin{bmatrix} y_G^2 + z_G^2 & -x_G y_G & -x_G z_G \\ -x_G y_G & x_G^2 + z_G^2 & -y_G z_G \\ -x_G z_G & -y_G z_G & x_G^2 + y_G^2 \end{bmatrix} = \begin{bmatrix} 8.533 & 4.267 & -4.267 \\ 4.267 & 8.533 & 4.267 \\ -4.267 & 4.267 & 8.533 \end{bmatrix} (\text{kg} \cdot \text{m}^2)$$

$$[\mathbf{I}_G] = [\mathbf{I}_P] - [\mathbf{I}_{mP}] = \begin{bmatrix} 792 & 356 & 36 \\ 356 & 792 & -76 \\ 36 & -76 & 792 \end{bmatrix} - \begin{bmatrix} 8.533 & 4.267 & -4.267 \\ 4.267 & 8.533 & 4.267 \\ -4.267 & 4.267 & 8.533 \end{bmatrix}$$

$$[\mathbf{I}_G] = \begin{bmatrix} 783.5 & 351.7 & 40.27 \\ 351.7 & 783.5 & -80.27 \\ 40.27 & -80.27 & 783.5 \end{bmatrix} \text{ (kg} \cdot \text{m}^2)$$

---

**Problem 9.6**

From the previous problem

$$[\mathbf{I}_O] = \begin{bmatrix} 792 & 356 & 36 \\ 356 & 792 & -76 \\ 36 & -76 & 792 \end{bmatrix} \text{ (kg} \cdot \text{m}^2)$$

$$\hat{\mathbf{i}}' = \frac{\hat{\mathbf{i}} + 2\hat{\mathbf{j}} + 2\hat{\mathbf{k}}}{\sqrt{1^2 + 2^2 + 2^2}} = 0.3333\hat{\mathbf{i}} + 0.6667\hat{\mathbf{j}} + 0.6667\hat{\mathbf{k}}$$

$$[\hat{\mathbf{i}}'] = [0.3333 \quad 0.6667 \quad 0.6667]$$

$$\begin{aligned} I_{x'} &= [\hat{\mathbf{i}}'] \begin{bmatrix} 792 & 356 & 36 \\ 356 & 792 & -76 \\ 36 & -76 & 792 \end{bmatrix} [\hat{\mathbf{i}}']^T \\ &= [0.3333 \quad 0.6667 \quad 0.6667] \begin{bmatrix} 792 & 356 & 36 \\ 356 & 792 & -76 \\ 36 & -76 & 792 \end{bmatrix} \begin{bmatrix} 0.3333 \\ 0.6667 \\ 0.6667 \end{bmatrix} \\ &= [0.3333 \quad 0.6667 \quad 0.6667] \begin{bmatrix} 535.3 \\ 596 \\ 489.3 \end{bmatrix} \end{aligned}$$

$$I_{x'} = 898.7 \text{ kg} \cdot \text{m}^2$$

---

**Problem 9.7**

$$[\mathbf{I}_G] = \frac{m}{12} \begin{bmatrix} b^2 + c^2 & -ab & -ac \\ -ab & a^2 + c^2 & -bc \\ -ac & -bc & a^2 + b^2 \end{bmatrix}$$

$$a = l \cos \theta$$

$$b = l \sin \theta$$

$$c = 0$$

$$[\mathbf{I}_G] = \frac{m}{12} \begin{bmatrix} (l \sin \theta)^2 + (0)^2 & -(l \cos \theta)(l \sin \theta) & -(l \cos \theta)(0) \\ -(l \cos \theta)(l \sin \theta) & (l \cos \theta)^2 + (0)^2 & -(l \sin \theta)(0) \\ -(l \cos \theta)(0) & -(l \sin \theta)(0) & (l \cos \theta)^2 + (l \sin \theta)^2 \end{bmatrix}$$

$$[\mathbf{I}_G] = \frac{ml^2}{12} \begin{bmatrix} \sin^2 \theta & -\frac{\sin 2\theta}{2} & 0 \\ -\frac{\sin 2\theta}{2} & \cos^2 \theta & 0 \\ 0 & 0 & 1 \end{bmatrix}$$

---



**Problem 9.8**

(a)

$$\begin{aligned}
 [\mathbf{I}_G] &= \frac{m}{12} \begin{bmatrix} b^2 + c^2 & 0 & 0 \\ 0 & a^2 + c^2 & 0 \\ 0 & 0 & a^2 + b^2 \end{bmatrix} \\
 &= \frac{1000}{12} \begin{bmatrix} 2^2 + 1^2 & 0 & 0 \\ 0 & 3^2 + 1^2 & 0 \\ 0 & 0 & 3^2 + 2^2 \end{bmatrix} \\
 &= \begin{bmatrix} 416.7 & 0 & 0 \\ 0 & 833.3 & 0 \\ 0 & 0 & 1083 \end{bmatrix} \text{ (kg} \cdot \text{m}^2)
 \end{aligned}$$

$$[\mathbf{I}_{mO}] = m \begin{bmatrix} y_G^2 + z_G^2 & -x_G y_G & -x_G z_G \\ -x_G y_G & x_G^2 + z_G^2 & -y_G z_G \\ -x_G z_G & -y_G z_G & x_G^2 + y_G^2 \end{bmatrix}$$

$$x_G = \frac{a}{2} = 1.5 \text{ m} \quad y_G = \frac{b}{2} = 1 \text{ m} \quad z_G = \frac{c}{2} = 0.5 \text{ m}$$

$$\therefore [\mathbf{I}_{mO}] = \begin{bmatrix} 1250 & -1500 & -750 \\ -1500 & 2500 & -500 \\ -750 & -500 & 3250 \end{bmatrix} \text{ (kg} \cdot \text{m}^2)$$

$$[\mathbf{I}_O] = [\mathbf{I}_G] + [\mathbf{I}_{mO}] = \begin{bmatrix} 416.7 & 0 & 0 \\ 0 & 833.3 & 0 \\ 0 & 0 & 1083 \end{bmatrix} + \begin{bmatrix} 1250 & -1500 & -750 \\ -1500 & 2500 & -500 \\ -750 & -500 & 3250 \end{bmatrix}$$

$$[\mathbf{I}_O] = \begin{bmatrix} 1667 & -1500 & -750 \\ -1500 & 3333 & -500 \\ -750 & -500 & 4333 \end{bmatrix} \text{ (kg} \cdot \text{m}^2)$$

(b)

$$\begin{vmatrix} 1667 - \lambda & -1500 & -750 \\ -1500 & 3333 - \lambda & -500 \\ -750 & -500 & 4333 - \lambda \end{vmatrix} = 0$$

$$\lambda^3 - 9333\lambda^2 + 24.16(10^6)\lambda - 10.91(10^9) = 0$$

$$\lambda_1 = 568.9 \text{ kg} \cdot \text{m}^2 \quad \lambda_2 = 4209 \text{ kg} \cdot \text{m}^2 \quad \lambda_3 = 4556 \text{ kg} \cdot \text{m}^2$$

Principal direction 1:

$$\begin{bmatrix} 1667 - 568.9 & -1500 & -750 \\ -1500 & 3333 - 568.9 & -500 \\ -750 & -500 & 4333 - 568.9 \end{bmatrix} \begin{Bmatrix} v_x^{(1)} \\ v_y^{(1)} \\ v_z^{(1)} \end{Bmatrix} = \begin{Bmatrix} 0 \\ 0 \\ 0 \end{Bmatrix}$$

$$\begin{bmatrix} 1098 & -1500 & -750 \\ -1500 & 2764 & -500 \\ -750 & -500 & 3764 \end{bmatrix} \begin{Bmatrix} 1 \\ v_y^{(1)} \\ v_z^{(1)} \end{Bmatrix} = \begin{Bmatrix} 0 \\ 0 \\ 0 \end{Bmatrix}$$

$$\begin{bmatrix} 2764 & -500 \\ -500 & 3764 \end{bmatrix} \begin{Bmatrix} v_y^{(1)} \\ v_z^{(1)} \end{Bmatrix} = \begin{Bmatrix} 1500 \\ 750 \end{Bmatrix}$$

$$\begin{Bmatrix} v_y^{(1)} \\ v_z^{(1)} \end{Bmatrix} = \begin{bmatrix} 2764 & -500 \\ -500 & 3764 \end{bmatrix}^{-1} \begin{Bmatrix} 1500 \\ 750 \end{Bmatrix} = \begin{Bmatrix} 0.5929 \\ 0.278 \end{Bmatrix}$$

$$\hat{\mathbf{v}}^{(1)} = \frac{\hat{\mathbf{i}} + 0.5829\hat{\mathbf{j}} + 0.278\hat{\mathbf{k}}}{\sqrt{1^2 + 0.5829^2 + 0.278^2}} = \underline{0.8366\hat{\mathbf{i}} + 0.496\hat{\mathbf{j}} + 0.2326\hat{\mathbf{k}}}$$

Principal direction 2:

$$\begin{bmatrix} 1667 - 4209 & -1500 & -750 \\ -1500 & 3333 - 4209 & -500 \\ -750 & -500 & 4333 - 4209 \end{bmatrix} \begin{Bmatrix} v_x^{(2)} \\ v_y^{(2)} \\ v_z^{(2)} \end{Bmatrix} = \begin{Bmatrix} 0 \\ 0 \\ 0 \end{Bmatrix}$$

$$\begin{bmatrix} -2542 & -1500 & -750 \\ -1500 & -875.5 & -500 \\ -750 & -500 & 124.5 \end{bmatrix} \begin{Bmatrix} 1 \\ v_y^{(2)} \\ v_z^{(2)} \end{Bmatrix} = \begin{Bmatrix} 0 \\ 0 \\ 0 \end{Bmatrix}$$

$$\begin{bmatrix} -875.5 & -500 \\ -500 & 124.5 \end{Bmatrix} \begin{Bmatrix} v_y^{(2)} \\ v_z^{(2)} \end{Bmatrix} = \begin{Bmatrix} 1500 \\ 750 \end{Bmatrix}$$

$$\begin{Bmatrix} v_y^{(2)} \\ v_z^{(2)} \end{Bmatrix} = \begin{bmatrix} -875.5 & -500 \\ -500 & 124.5 \end{bmatrix}^{-1} \begin{Bmatrix} 1500 \\ 750 \end{Bmatrix} = \begin{Bmatrix} -1.565 \\ -0.2601 \end{Bmatrix}$$

$$\hat{\mathbf{v}}^{(2)} = \frac{\hat{\mathbf{i}} - 1.565\hat{\mathbf{j}} - 0.2601\hat{\mathbf{k}}}{\sqrt{1^2 + (-1.565)^2 + (-0.2601)^2}} = \underline{0.5333\hat{\mathbf{i}} - 0.8345\hat{\mathbf{j}} - 0.1387\hat{\mathbf{k}}}$$

Principal direction 3:

$$\begin{bmatrix} 1667 - 4556 & -1500 & -750 \\ -1500 & 3333 - 4556 & -500 \\ -750 & -500 & 4333 - 4556 \end{bmatrix} \begin{Bmatrix} v_x^{(3)} \\ v_y^{(3)} \\ v_z^{(3)} \end{Bmatrix} = \begin{Bmatrix} 0 \\ 0 \\ 0 \end{Bmatrix}$$

$$\begin{bmatrix} -2889 & -1500 & -750 \\ -1500 & -1222 & -500 \\ -750 & -500 & -222.3 \end{bmatrix} \begin{Bmatrix} 1 \\ v_y^{(3)} \\ v_z^{(3)} \end{Bmatrix} = \begin{Bmatrix} 0 \\ 0 \\ 0 \end{Bmatrix}$$

$$\begin{bmatrix} -1222 & -500 \\ -500 & -222.3 \end{bmatrix} \begin{Bmatrix} v_y^{(3)} \\ v_z^{(3)} \end{Bmatrix} = \begin{Bmatrix} 1500 \\ 750 \end{Bmatrix}$$

$$\begin{Bmatrix} v_y^{(3)} \\ v_z^{(3)} \end{Bmatrix} = \begin{bmatrix} -1222 & -500 \\ -500 & -222.3 \end{bmatrix}^{-1} \begin{Bmatrix} 1500 \\ 750 \end{Bmatrix} = \begin{Bmatrix} 1.916 \\ -7.685 \end{Bmatrix}$$

$$\hat{\mathbf{v}}^{(3)} = \frac{\hat{\mathbf{i}} + 1.916\hat{\mathbf{j}} - 7.685\hat{\mathbf{k}}}{\sqrt{1^2 + 1.916^2 + (-7.685)^2}} = \underline{0.1253\hat{\mathbf{i}} + 0.2401\hat{\mathbf{j}} - 0.9626\hat{\mathbf{k}}}$$

The following MATLAB script uses the built-in function `eig` to obtain these results, as shown in the Command Window output which follows.

```
fprintf('\n-----\n')
Matrix = [ 1666.7    -1500    -750
          -1500   3333.3    -500
           -750    -500   4333.3]

[eigvector, eigvalue] = eig(I);

fprintf('\n Eigenvalue           Eigenvector')
for i = 1:3
```

```

fprintf('\n %g      [%g %g %g]', eigvalue(i,i), eigvector(1,i),
eigvector(2,i), eigvector(3,i))
end
fprintf('\n-----\n')

```

-----

Matrix =

1666.7	-1500	-750
-1500	3333.3	-500
-750	-500	4333.3

Eigenvalue	Eigenvector
4208.83	[-0.533304 0.834478 0.138683]
4555.59	[0.125278 0.240046 -0.962644]
568.881	[0.836596 0.496008 0.232559]

-----

(c)

$$\hat{\mathbf{i}}' = \frac{3\hat{\mathbf{i}} + 2\hat{\mathbf{j}} + \hat{\mathbf{k}}}{\sqrt{3^2 + 2^2 + 1^2}} = 0.8018\hat{\mathbf{i}} + 0.5345\hat{\mathbf{j}} + 0.2673\hat{\mathbf{k}}$$

$$[\hat{\mathbf{i}}'] = [0.8018 \quad 0.5345 \quad 0.2673]$$

$$I_{x'} = [\hat{\mathbf{i}}'] [\mathbf{I}_O] [\hat{\mathbf{i}}']^T = [0.8018 \quad 0.5345 \quad 0.2673] \begin{bmatrix} 1667 & -1500 & -750 \\ -1500 & 3333 & -500 \\ -750 & -500 & 4333 \end{bmatrix} \begin{bmatrix} 0.8018 \\ 0.5345 \\ 0.2673 \end{bmatrix}$$

$$I_{x'} = [0.8018 \quad 0.5345 \quad 0.2673] \begin{Bmatrix} 334.1 \\ 445.4 \\ 239.5 \end{Bmatrix}$$

$$I_{x'} = 583.3 \text{ kg} \cdot \text{m}^2$$

**Problem 9.9**

$$\{\mathbf{H}_C\} = [\mathbf{I}_C] \{\boldsymbol{\omega}\} = \frac{ml^2}{12} \begin{bmatrix} 1 & 0 & 0 \\ 0 & \sin^2 \theta & -\frac{\sin 2\theta}{2} \\ 0 & -\frac{\sin 2\theta}{2} & \cos^2 \theta \end{bmatrix} \begin{Bmatrix} \omega \\ 0 \\ \Omega \end{Bmatrix} = \begin{Bmatrix} \frac{1}{12} ml^2 \omega \\ -\frac{1}{24} ml^2 \Omega \sin 2\theta \\ \frac{1}{12} ml^2 \Omega \cos^2 \theta \end{Bmatrix}$$

$$\mathbf{H}_C = \frac{1}{12} ml^2 \omega \hat{\mathbf{i}} - \frac{1}{24} ml^2 \Omega \sin 2\theta \hat{\mathbf{j}} + \frac{1}{12} ml^2 \Omega \cos^2 \theta \hat{\mathbf{k}}$$

$$\mathbf{H}_P = \mathbf{H}_C + \mathbf{r}_{C/P} \times m\mathbf{v}_C$$

$$\mathbf{r}_{C/P} = d\hat{\mathbf{i}} \quad \mathbf{v}_C = \Omega \hat{\mathbf{k}} \times d\hat{\mathbf{i}} = \Omega d\hat{\mathbf{j}}$$

$$\mathbf{H}_P = \mathbf{H}_C + d\hat{\mathbf{i}} \times m\Omega d\hat{\mathbf{j}} = \mathbf{H}_C + m\Omega d^2 \hat{\mathbf{k}}$$

$$\mathbf{H}_P = \left( \frac{1}{12} ml^2 \omega \hat{\mathbf{i}} - \frac{1}{24} ml^2 \Omega \sin 2\theta \hat{\mathbf{j}} + \frac{1}{12} ml^2 \Omega \cos^2 \theta \hat{\mathbf{k}} \right) + m\Omega d^2 \hat{\mathbf{k}}$$

$$\mathbf{H}_P = \frac{1}{12} ml^2 \omega \hat{\mathbf{i}} - \frac{1}{24} ml^2 \Omega \sin 2\theta \hat{\mathbf{j}} + \left( \frac{1}{12} ml^2 \cos^2 \theta + md^2 \right) \Omega \hat{\mathbf{k}}$$

**Problem 9.10**

$$\begin{bmatrix} 1000 & 0 & -300 \\ 0 & 1000 & 500 \\ -300 & 500 & 1000 \end{bmatrix} \begin{Bmatrix} \omega_x \\ \omega_y \\ \omega_z \end{Bmatrix} = 1000 \begin{Bmatrix} \omega_x \\ \omega_y \\ \omega_z \end{Bmatrix}$$

$$\begin{cases} 1000\omega_x - 300\omega_z \\ 1000\omega_y + 500\omega_z \\ -300\omega_x + 500\omega_y + 1000\omega_z \end{cases} = \begin{cases} 1000\omega_x \\ 1000\omega_y \\ 1000\omega_z \end{cases}$$

$$\begin{cases} -300\omega_z \\ 500\omega_z \\ -300\omega_x + 500\omega_y \end{cases} = \begin{cases} 0 \\ 0 \\ 0 \end{cases}$$

$$\omega_z = 0$$

$$-300\omega_x + 500\omega_y = 0 \Rightarrow \omega_y = \frac{3}{5}\omega$$

$$\therefore \boldsymbol{\omega} = \begin{Bmatrix} \omega_x \\ \frac{3}{5}\omega_x \\ 0 \end{Bmatrix}$$

$$\|\boldsymbol{\omega}\| = 1.166\omega_x = 20 \Rightarrow \omega_x = 17.15$$

$$\therefore \boldsymbol{\omega} = \begin{Bmatrix} 17.15 \\ 10.29 \\ 0 \end{Bmatrix} \text{ or } \underline{\boldsymbol{\omega} = 17.15\hat{\mathbf{i}} + 10.29\hat{\mathbf{j}} \text{ (s}^{-1}\text{)}}$$

**Problem 9.11**

$$\boldsymbol{\omega} = 2t^2\hat{\mathbf{i}} + 4\hat{\mathbf{j}} + 3t\hat{\mathbf{k}}$$

$$\boldsymbol{\alpha} = \left. \frac{d\boldsymbol{\omega}}{dt} \right|_{rel} + \boldsymbol{\omega} \times \boldsymbol{\omega} = \left. \frac{d\boldsymbol{\omega}}{dt} \right|_{rel}$$

$$\boldsymbol{\alpha} = 4t\hat{\mathbf{i}} + 3\hat{\mathbf{k}}$$

$$t = 3:$$

$$\boldsymbol{\omega} = 18\hat{\mathbf{i}} + 4\hat{\mathbf{j}} + 9\hat{\mathbf{k}}$$

$$\boldsymbol{\alpha} = 12\hat{\mathbf{i}} + 3\hat{\mathbf{k}}$$

$$\{\mathbf{M}\} = [\mathbf{I}_G]\{\boldsymbol{\alpha}\} + \{\boldsymbol{\omega}\} \times [\mathbf{I}_G]\{\boldsymbol{\omega}\}$$

$$\{\mathbf{M}\} = \begin{bmatrix} 10 & 0 & 0 \\ 0 & 20 & 0 \\ 0 & 0 & 30 \end{bmatrix} \begin{Bmatrix} 12 \\ 0 \\ 3 \end{Bmatrix} + \begin{Bmatrix} 18 \\ 4 \\ 9 \end{Bmatrix} \times \begin{bmatrix} 10 & 0 & 0 \\ 0 & 20 & 0 \\ 0 & 0 & 30 \end{bmatrix} \begin{Bmatrix} 18 \\ 4 \\ 9 \end{Bmatrix}$$

$$\{\mathbf{M}\} = \begin{Bmatrix} 120 \\ 0 \\ 90 \end{Bmatrix} + \begin{Bmatrix} 18 \\ 4 \\ 9 \end{Bmatrix} \times \begin{Bmatrix} 180 \\ 80 \\ 270 \end{Bmatrix}$$

$$\mathbf{M} = (120\hat{\mathbf{i}} + 90\hat{\mathbf{k}}) + \begin{vmatrix} \hat{\mathbf{i}} & \hat{\mathbf{j}} & \hat{\mathbf{k}} \\ 18 & 4 & 9 \\ 180 & 80 & 270 \end{vmatrix} = (120\hat{\mathbf{i}} + 90\hat{\mathbf{k}}) + (360\hat{\mathbf{i}} - 3240\hat{\mathbf{j}} + 720\hat{\mathbf{k}})$$

$$\mathbf{M} = 480\hat{\mathbf{i}} - 3240\hat{\mathbf{j}} + 810\hat{\mathbf{k}}$$

$$M = \|\mathbf{M}\| = \sqrt{480^2 + (-3240)^2 + 810^2} = 3374 \text{ N}\cdot\text{m}$$

**Problem 9.12**

$$\{\mathbf{M}_G\} = [\mathbf{I}_G]\{\boldsymbol{\alpha}\} + \{\boldsymbol{\omega}\} \times [\mathbf{I}_G]\{\boldsymbol{\omega}\}$$

$$\{\boldsymbol{\omega}\} = 0$$

$$\mathbf{M}_G = \mathbf{r} \times \mathbf{F} = [(0 - 0.075)\hat{\mathbf{i}} + (0 - 0.2536)\hat{\mathbf{j}} + (0 - 0.05714)\hat{\mathbf{k}}] \times 100\hat{\mathbf{i}} = 34.29\hat{\mathbf{j}} + 25.36\hat{\mathbf{k}} \text{ (N} \cdot \text{m)}$$

$$\begin{Bmatrix} 0 \\ 34.29 \\ 25.36 \end{Bmatrix} = \begin{bmatrix} 0.1522 & -0.03975 & 0.0120 \\ -0.03975 & 0.07177 & 0.04057 \\ 0.0120 & 0.04057 & 0.1569 \end{bmatrix} \begin{Bmatrix} \alpha_X \\ \alpha_Y \\ \alpha_Z \end{Bmatrix}$$

$$\begin{Bmatrix} \alpha_X \\ \alpha_Y \\ \alpha_Z \end{Bmatrix} = \begin{bmatrix} 0.1522 & -0.03975 & 0.0120 \\ -0.03975 & 0.07177 & 0.04057 \\ 0.0120 & 0.04057 & 0.1569 \end{bmatrix}^{-1} \begin{Bmatrix} 0 \\ 34.29 \\ 25.36 \end{Bmatrix} = \begin{Bmatrix} 143.9 \\ 553.1 \\ 7.61 \end{Bmatrix} \text{ (m/s}^2\text{)}$$

**Problem 9.13**

(a)

$$\sum F_x = ma_{Gx}$$

$$mg \sin \theta = m \left( \frac{v^2}{R} \cos \theta \right)$$

$$\tan \theta = \frac{v^2}{gR}$$

(b)

$$\mathbf{M} = \boldsymbol{\omega} \times \mathbf{H} = \begin{vmatrix} \hat{\mathbf{i}} & \hat{\mathbf{j}} & \hat{\mathbf{k}} \\ \omega_x & \omega_y & \omega_z \\ A\omega_x & B\omega_y & C\omega_z \end{vmatrix} = (C - B)\omega_y\omega_z\hat{\mathbf{i}} + (A - C)\omega_x\omega_z\hat{\mathbf{j}} + (B - A)\omega_x\omega_y\hat{\mathbf{k}}$$

$$\omega_x = -\frac{v}{R} \sin \theta \quad \omega_y = 0 \quad \omega_z = \frac{v}{R} \cos \theta$$

$$\mathbf{M} = (A - C) \left( -\frac{v}{R} \sin \theta \right) \left( \frac{v}{R} \cos \theta \right) \hat{\mathbf{j}}$$

$$M_y = (C - A) \frac{v^2}{R^2} \sin \theta \cos \theta = (C - A) \frac{v^2}{2R^2} \sin 2\theta$$

**Problem 9.14**

$$\mathbf{M} = \boldsymbol{\omega} \times \mathbf{H} = \begin{vmatrix} \hat{\mathbf{i}} & \hat{\mathbf{j}} & \hat{\mathbf{k}} \\ \omega_x & \omega_y & \omega_z \\ A\omega_x & B\omega_y & C\omega_z \end{vmatrix} = (C - B)\omega_y\omega_z\hat{\mathbf{i}} + (A - C)\omega_x\omega_z\hat{\mathbf{j}} + (B - A)\omega_x\omega_y\hat{\mathbf{k}}$$

$$\omega_x = 0 \quad \omega_y = \omega_Z \sin \alpha \quad \omega_z = \omega_Z \cos \alpha$$

$$\mathbf{M} = (C - B)(\omega_Z \sin \alpha)(\omega_Z \cos \alpha) \hat{\mathbf{i}}$$

$$M_x = \frac{1}{2}(C - B)\omega_Z^2 \sin 2\alpha \quad M_y = 0 \quad M_z = 0$$

**Problem 9.15**

$$x_{G1} = -\left(\frac{l}{2} - \frac{l}{3}\right) \cos \theta = -\frac{l}{6} \cos \theta$$

$$y_{G1} = \frac{l}{6} \sin \theta$$

$$z_{G1} = 0$$

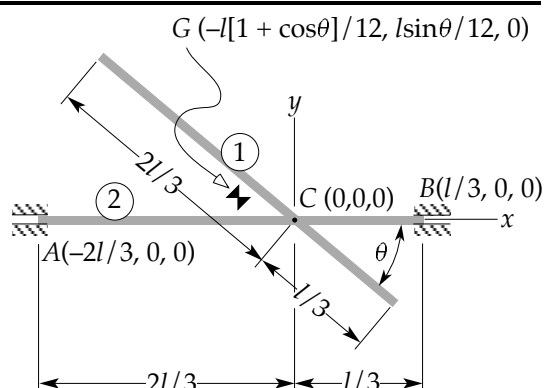

$$x_{G_2} = -\frac{l}{6}$$

$$y_{G_2} = z_{G_2} = 0$$

$$x_G = \frac{mx_{G_1} + mx_{G_2}}{2m} = \frac{1}{2} \left( -\frac{l}{6} \cos \theta - \frac{l}{6} \right) = -\frac{l}{12} (1 + \cos \theta)$$

$$y_G = \frac{my_{G_1} + my_{G_2}}{2m} = \frac{1}{2} \left( \frac{l}{6} \sin \theta \right) = \frac{l}{12} \sin \theta$$

$$z_G = 0$$

Free-body diagram (no bearing couples and no thrust components of bearing force):

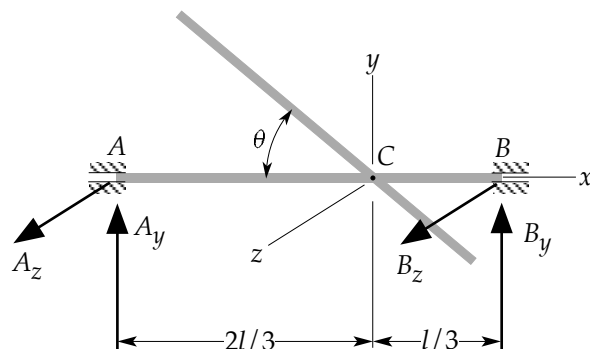

$$\sum F_x = 2ma_{G_x}: \quad 0 = 0$$

$$\sum F_y = 2ma_{G_y}: \quad A_y + B_y = -\frac{m\omega^2 l}{6} \sin \theta \quad (1)$$

$$\sum F_z = 2ma_{G_z}: \quad A_z + B_z = 0 \quad (2)$$

Moments of inertia about  $G_1$  (inferred from results of Exercise 9.7):

$$\left[ \mathbf{I}_{G_1}^{(1)} \right] = \frac{ml^2}{12} \begin{bmatrix} \sin^2 \theta & \frac{1}{2} \sin 2\theta & 0 \\ \frac{1}{2} \sin 2\theta & \cos^2 \theta & 0 \\ 0 & 0 & 1 \end{bmatrix}$$

From Equation 9.60:

$$\left[ \mathbf{I}_{mC}^{(1)} \right] = m \begin{bmatrix} y_{G_1}^2 + z_{G_1}^2 & -x_{G_1}y_{G_1} & -x_{G_1}z_{G_1} \\ -x_{G_1}y_{G_1} & x_{G_1}^2 + z_{G_1}^2 & -y_{G_1}z_{G_1} \\ -x_{G_1}z_{G_1} & -y_{G_1}z_{G_1} & x_{G_1}^2 + y_{G_1}^2 \end{bmatrix}$$

$$= m \begin{bmatrix} \left( \frac{l}{6} \sin \theta \right)^2 & -\left( -\frac{l}{6} \cos \theta \right) \frac{l}{6} \sin \theta & 0 \\ -\left( -\frac{l}{6} \cos \theta \right) \frac{l}{6} \sin \theta & \left( -\frac{l}{6} \cos \theta \right)^2 & 0 \\ 0 & 0 & \left( -\frac{l}{6} \cos \theta \right)^2 + \left( \frac{l}{6} \sin \theta \right)^2 \end{bmatrix}$$

$$[\mathbf{I}_{mC}^{(1)}] = \frac{ml^2}{12} \begin{bmatrix} \frac{1}{3}\sin^2\theta & \frac{1}{6}\sin 2\theta & 0 \\ \frac{1}{6}\sin 2\theta & \frac{1}{3}\cos^2\theta & 0 \\ 0 & 0 & \frac{1}{3} \end{bmatrix}$$

$$[\mathbf{I}_C^{(1)}] = [\mathbf{I}_{G_1}^{(1)}] + [\mathbf{I}_{mC}^{(1)}] = \frac{ml^2}{12} \begin{bmatrix} \sin^2\theta & \frac{1}{2}\sin 2\theta & 0 \\ \frac{1}{2}\sin 2\theta & \cos^2\theta & 0 \\ 0 & 0 & 1 \end{bmatrix} + \frac{ml^2}{12} \begin{bmatrix} \frac{1}{3}\sin^2\theta & \frac{1}{6}\sin 2\theta & 0 \\ \frac{1}{6}\sin 2\theta & \frac{1}{3}\cos^2\theta & 0 \\ 0 & 0 & \frac{1}{3} \end{bmatrix}$$

$$[\mathbf{I}_C^{(1)}] = \frac{ml^2}{12} \begin{bmatrix} \frac{4}{3}\sin^2\theta & \frac{2}{3}\sin 2\theta & 0 \\ \frac{2}{3}\sin 2\theta & \frac{4}{3}\cos^2\theta & 0 \\ 0 & 0 & \frac{4}{3} \end{bmatrix}$$

$$[\mathbf{I}_{G_2}^{(2)}] = \frac{ml^2}{12} \begin{bmatrix} 0 & 0 & 0 \\ 0 & 1 & 0 \\ 0 & 0 & 1 \end{bmatrix}$$

$$[\mathbf{I}_{mC}^{(2)}] = m \begin{bmatrix} y_{G_2}^2 + z_{G_2}^2 & -x_{G_2}y_{G_2} & -x_{G_2}z_{G_2} \\ -x_{G_2}y_{G_2} & x_{G_2}^2 + z_{G_2}^2 & -y_{G_2}z_{G_2} \\ -x_{G_2}z_{G_2} & -y_{G_2}z_{G_2} & x_{G_2}^2 + y_{G_2}^2 \end{bmatrix} = m \begin{bmatrix} 0 & 0 & 0 \\ 0 & \left(-\frac{l}{6}\right)^2 & 0 \\ 0 & 0 & \left(-\frac{l}{6}\right)^2 \end{bmatrix}$$

$$[\mathbf{I}_{mC}^{(2)}] = \frac{ml^2}{12} \begin{bmatrix} 0 & 0 & 0 \\ 0 & \frac{1}{3} & 0 \\ 0 & 0 & \frac{1}{3} \end{bmatrix}$$

$$[\mathbf{I}_C^{(2)}] = [\mathbf{I}_{G_2}^{(2)}] + [\mathbf{I}_{mC}^{(2)}] = \frac{ml^2}{12} \begin{bmatrix} 0 & 0 & 0 \\ 0 & 1 & 0 \\ 0 & 0 & 1 \end{bmatrix} + \frac{ml^2}{12} \begin{bmatrix} 0 & 0 & 0 \\ 0 & \frac{1}{3} & 0 \\ 0 & 0 & \frac{1}{3} \end{bmatrix}$$

$$[\mathbf{I}_C^{(2)}] = \frac{ml^2}{12} \begin{bmatrix} 0 & 0 & 0 \\ 0 & \frac{4}{3} & 0 \\ 0 & 0 & \frac{4}{3} \end{bmatrix}$$

$$[\mathbf{I}_C] = [\mathbf{I}_C^{(1)}] + [\mathbf{I}_C^{(2)}] = \frac{ml^2}{12} \begin{bmatrix} \frac{4}{3}\sin^2\theta & \frac{2}{3}\sin 2\theta & 0 \\ \frac{2}{3}\sin 2\theta & \frac{4}{3}\cos^2\theta & 0 \\ 0 & 0 & \frac{4}{3} \end{bmatrix} + \frac{ml^2}{12} \begin{bmatrix} 0 & 0 & 0 \\ 0 & \frac{4}{3} & 0 \\ 0 & 0 & \frac{4}{3} \end{bmatrix}$$

$$[\mathbf{I}_C] = \begin{bmatrix} \frac{ml^2}{9} \sin^2 \theta & \frac{ml^2}{18} \sin 2\theta & 0 \\ \frac{ml^2}{18} \sin 2\theta & \frac{ml^2}{9} (1 + \cos^2 \theta) & 0 \\ 0 & 0 & \frac{2ml^2}{9} \end{bmatrix}$$

$$\{\mathbf{H}_C\} = [\mathbf{I}_C]\{\boldsymbol{\omega}\} = \begin{bmatrix} \frac{ml^2}{9} \sin^2 \theta & \frac{ml^2}{18} \sin 2\theta & 0 \\ \frac{ml^2}{18} \sin 2\theta & \frac{ml^2}{9} (1 + \cos^2 \theta) & 0 \\ 0 & 0 & \frac{2ml^2}{9} \end{bmatrix} \begin{Bmatrix} \omega \\ 0 \\ 0 \end{Bmatrix} = \begin{Bmatrix} \frac{ml^2 \omega}{9} \sin^2 \theta \\ \frac{ml^2 \omega}{18} \sin 2\theta \\ 0 \end{Bmatrix}$$

$$\mathbf{M}_C = \boldsymbol{\omega} \times \mathbf{H}_C = \begin{vmatrix} \hat{\mathbf{i}} & \hat{\mathbf{j}} & \hat{\mathbf{k}} \\ \omega & 0 & 0 \\ \frac{ml^2 \omega}{9} \sin^2 \theta & \frac{ml^2 \omega}{18} \sin 2\theta & 0 \end{vmatrix} = \frac{ml^2 \omega^2}{18} \sin 2\theta \hat{\mathbf{k}}$$

$$M_{C_x} = 0 \quad (3)$$

$$M_{C_y} = 0 \quad (4)$$

$$M_{C_z} = \frac{ml^2 \omega^2}{18} \sin 2\theta \quad (5)$$

Calculate the moments of the bearing reactions in the above free body diagram:

$$\mathbf{M}_C = \left(-\frac{2}{3} \hat{\mathbf{i}}\right) \times (A_y \hat{\mathbf{j}} + A_z \hat{\mathbf{k}}) + \left(\frac{l}{3} \hat{\mathbf{i}}\right) \times (B_y \hat{\mathbf{j}} + B_z \hat{\mathbf{k}}) = \left(\frac{2}{3} A_z l - \frac{1}{3} B_z l\right) \hat{\mathbf{j}} + \left(-\frac{2}{3} A_y l + \frac{1}{3} B_y l\right) \hat{\mathbf{j}}$$

$$M_{C_x} = 0 \quad (6)$$

$$M_{C_y} = \frac{2}{3} A_z l - \frac{1}{3} B_z l \quad (7)$$

$$M_{C_z} = -\frac{2}{3} A_y l + \frac{1}{3} B_y l \quad (8)$$

From (4) and (7)

$$2A_z - B_z = 0 \quad (9)$$

From (5) and (8)

$$-\frac{2}{3} A_y l + \frac{1}{3} B_y l = \frac{ml^2 \omega^2}{18} \sin 2\theta \quad (10)$$

From (1) we have

$$B_y = -\frac{m\omega^2 l}{6} \sin \theta - A_y \quad (11)$$

Substituting this into (10):

$$-\frac{2}{3} A_y l + \frac{1}{3} \left(-\frac{m\omega^2 l}{6} \sin \theta - A_y\right) l = \frac{ml^2 \omega^2}{18} \sin 2\theta \Rightarrow A_y = -\frac{ml^2 \omega^2}{18} \sin \theta (1 + 2 \cos \theta) \quad (12)$$



Therefore, from (11),

$$B_y = -\frac{m\omega^2 l}{6} \sin \theta - \left[ -\frac{ml^2 \omega^2}{18} \sin \theta (1 + 2 \cos \theta) \right] = -\frac{m\omega^2 l}{9} \sin \theta (1 - \cos \theta) \quad (13)$$

From (2) we have

$$B_z = -A_z$$

Substituting this into (9)

$$2A_z - (-A_z) = 0 \Rightarrow A_z = 0$$

Therefore,  $B_z = 0$ .

The only reactions at each bearing are in the plane of the rod and shaft, normal to the shaft, as given by Equations (12) and (13).

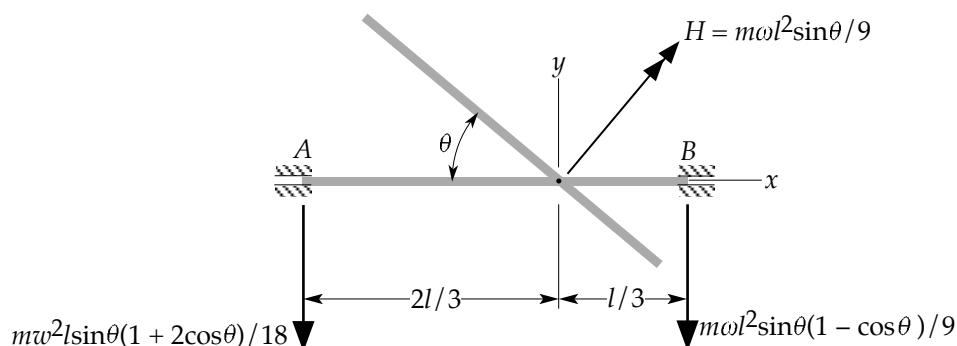

### Problem 9.16

$$\mathbf{M}_G = \dot{\mathbf{H}}_G)_{rel} + \boldsymbol{\omega} \times \mathbf{H}$$

$$\mathbf{M}_G = A\dot{\omega}_x \hat{\mathbf{i}} + B\dot{\omega}_y \hat{\mathbf{j}} + C\dot{\omega}_z \hat{\mathbf{k}} + \begin{vmatrix} \hat{\mathbf{i}} & \hat{\mathbf{j}} & \hat{\mathbf{k}} \\ \omega_x & \omega_y & \omega_z \\ A\omega_x & B\omega_y & C\omega_z \end{vmatrix}$$

$$600\hat{\mathbf{i}} + M_{Gy}\hat{\mathbf{j}} + M_{Gz}\hat{\mathbf{k}} = 5\dot{\omega}_x \hat{\mathbf{i}} + 5(0)\hat{\mathbf{j}} + 10(0)\hat{\mathbf{k}} + \begin{vmatrix} \hat{\mathbf{i}} & \hat{\mathbf{j}} & \hat{\mathbf{k}} \\ 0 & 0.5 & 100 \\ 5(0) & 5 \cdot 0.5 & 10 \cdot 100 \end{vmatrix}$$

$$600\hat{\mathbf{i}} + M_{Gy}\hat{\mathbf{j}} + M_{Gz}\hat{\mathbf{k}} = (5\dot{\omega}_x + 250)\hat{\mathbf{i}}$$

$$5\dot{\omega}_x + 250 = 600 \Rightarrow \dot{\omega}_x = 70 \text{ rad/s}^2$$

### Problem 9.17

$$\mathbf{M}_O = I_{Ox}\dot{\omega}_x \hat{\mathbf{i}} + I_{Oy}\dot{\omega}_y \hat{\mathbf{j}} + I_{Oz}\dot{\omega}_z \hat{\mathbf{k}} + \begin{vmatrix} \hat{\mathbf{i}} & \hat{\mathbf{j}} & \hat{\mathbf{k}} \\ \omega_x & \omega_y & \omega_z \\ I_{Ox}\omega_x & I_{Oy}\omega_y & I_{Oz}\omega_z \end{vmatrix}$$

$$I_{Ox} = I_{Oz} = \frac{1}{12} mL^2 + m\left(\frac{L}{6}\right)^2 = \frac{mL^2}{9} \quad I_{Oy} = 0$$

$$\alpha_x = \alpha_y = \alpha_z = 0$$

$$\omega_x = 0 \quad \omega_y = -\omega \cos \theta \quad \omega_z = \omega \sin \theta$$

$$\mathbf{M}_O = \begin{vmatrix} \hat{\mathbf{i}} & \hat{\mathbf{j}} & \hat{\mathbf{k}} \\ 0 & -\omega \cos \theta & \omega \sin \theta \\ 0 & 0 & \frac{mL^2}{9} \omega \sin \theta \end{vmatrix} = -\frac{1}{9} m \omega^2 L^2 \sin \theta \cos \theta \hat{\mathbf{i}}$$

$$\therefore M_{O_x} = -\frac{1}{9} m \omega^2 L^2 \sin \theta \cos \theta$$

Moment of the weight vector about O:

$$M_{O_x} = -mg \frac{L}{6} \sin \theta$$

$$\therefore -\frac{1}{9} m \omega^2 L^2 \sin \theta \cos \theta = -mg \frac{L}{6} \sin \theta \Rightarrow \omega = \sqrt{\frac{3}{2} \frac{g}{L \sin \theta}}$$

### Problem 9.18

$$\mathbf{M}_G = \dot{\mathbf{H}}_G)_{rel} + \boldsymbol{\Omega} \times \mathbf{H}$$

$$\mathbf{M}_G = I_{Gx} \alpha_x \hat{\mathbf{i}} + I_{Gy} \alpha_y \hat{\mathbf{j}} + I_{Gz} \alpha_z \hat{\mathbf{k}} + \begin{vmatrix} \hat{\mathbf{i}} & \hat{\mathbf{j}} & \hat{\mathbf{k}} \\ \Omega_x & \Omega_y & \Omega_z \\ I_{Gx} \omega_x & I_{Gy} \omega_y & I_{Gz} \omega_z \end{vmatrix}$$

$$10 \cdot 9.81 \cdot 0.25 \hat{\mathbf{i}} = 0 + \begin{vmatrix} \hat{\mathbf{i}} & \hat{\mathbf{j}} & \hat{\mathbf{k}} \\ 0 & \omega_p & 630 \\ 0 & 0.01406 \omega_p & 0.02812 \cdot 630 \end{vmatrix}$$

$$24.52 \hat{\mathbf{i}} = 17.72 \omega_p \hat{\mathbf{i}} \Rightarrow \omega_p = \underline{1.384 \text{ rad/s}}$$

Or, using Equation 9.96,

$$\omega_p = \frac{mgd}{I_z \omega_s} = \frac{10 \cdot 9.81 \cdot 0.25}{0.02812 \cdot 630} = \underline{\omega_p = 1.384 \text{ rad/s}}$$

### Problem 9.19

$$\omega_{wheel} = \frac{v}{r} = \frac{130 \frac{1000}{3600}}{0.3} = 120.4 \text{ rad/s}$$

$$I_{wheel} = 25 \cdot 0.2^2 = 1 \text{ kg} \cdot \text{m}^2$$

$$\mathbf{M} = \boldsymbol{\omega}_p \times \mathbf{H}_s = 0.8 \hat{\mathbf{j}} \times [1 \cdot 120.4 \hat{\mathbf{k}}] = \underline{96.3 \hat{\mathbf{i}} \text{ (N} \cdot \text{m)}}$$

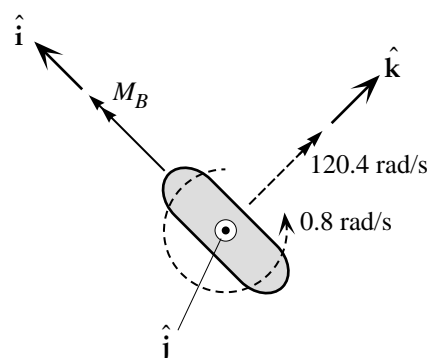

**Problem 9.20**

$$I_{rotor} = 4 \cdot 0.07^2 = 0.0196 \text{ kg} \cdot \text{m}^2$$

$$\mathbf{M} = \boldsymbol{\omega}_p \times \mathbf{H}_s = 2\hat{\mathbf{i}} \times \left( 0.0196 \cdot 10000 \cdot \frac{2\pi}{60} \hat{\mathbf{k}} \right) = 41.05\hat{\mathbf{j}} \text{ (N} \cdot \text{m)}$$

$$B_y = F \quad A_y = -F$$

$$0.04F = 41.05$$

$$F = 1026 \text{ N}$$

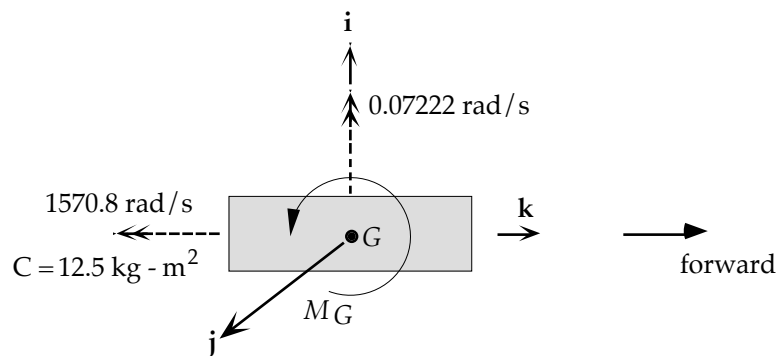
**Problem 9.21**

$$I_{rotor} = 200 \cdot 0.25^2 = 12.5 \text{ kg} \cdot \text{m}^2$$

$$\omega_s = 15000 \cdot \frac{2\pi}{60} = 1571 \text{ rad/s}$$

$$\omega_p = \frac{v}{r} = \frac{650000}{2500} = 0.07222 \text{ rad/s}$$

$$\mathbf{M} = \boldsymbol{\omega}_p \times \mathbf{H}_s = 0.07222\hat{\mathbf{i}} \times [12.5(-1571\hat{\mathbf{k}})] = 1418\hat{\mathbf{i}} \text{ (N} \cdot \text{m)}$$

The moment reaction on the airframe is clockwise, pitching the nose down.

**Problem 9.22**

$$\mathbf{M}_G = \boldsymbol{\omega}_p \times \mathbf{H}_s$$

$$\boldsymbol{\omega}_p = 20\hat{\mathbf{i}} \text{ (rad/s)}$$

$$\mathbf{H}_s = \frac{1}{2} \cdot 10 \cdot 0.05^2 \cdot 200\hat{\mathbf{k}} = 2.5\hat{\mathbf{k}} \text{ (kg} \cdot \text{m}^2/\text{s}^2)$$

$$\mathbf{M}_G = 20\hat{\mathbf{i}} \times 2.5\hat{\mathbf{k}} = -50\hat{\mathbf{j}} \text{ (N} \cdot \text{m)}$$

$$0.6R_B\hat{\mathbf{j}} = -50\hat{\mathbf{j}}$$

$$R_B = -83.33 \text{ N} \quad R_A = -R_B = 83.33 \text{ N}$$

**Problem 9.23**

$$\begin{aligned} l_x &= \cos\psi \cos\phi - \sin\phi \sin\psi \cos\theta \\ &= \cos 70^\circ \cos 50^\circ - \sin 50^\circ \sin 70^\circ \cos 25^\circ \\ &= 0.6428 \cdot 0.3420 - 0.7660 \cdot 0.9397 \cdot 0.9063 \\ &= -0.4326 \end{aligned}$$

$$\alpha_{xX} = \cos^{-1}(-0.4326) = 115.6^\circ$$

**Problem 9.24**

$$\{\mathbf{H}\} = [\mathbf{I}]\{\boldsymbol{\omega}\} = \begin{bmatrix} 20 & -10 & 0 \\ -10 & 30 & 0 \\ 0 & 0 & 40 \end{bmatrix} \begin{Bmatrix} 10 \\ 20 \\ 30 \end{Bmatrix} = \begin{Bmatrix} 0 \\ 500 \\ 1500 \end{Bmatrix} \quad (\text{J} \cdot \text{s})$$

$$T = \frac{1}{2} \mathbf{H} \cdot \boldsymbol{\omega} = \frac{1}{2} [0 \quad 500 \quad 1500] \begin{Bmatrix} 10 \\ 20 \\ 30 \end{Bmatrix} = \underline{23\,000 \text{ J}}$$

---



**Problem 10.1**

$$\omega_p = \frac{C}{A-C} \frac{\omega_s}{\cos\theta} = \frac{1200}{2600-1200} \frac{6}{\cos 6^\circ} = 5.171 \text{ rad/s}$$

$$H = A\omega_p = 2600 \cdot 5.171 = \underline{13450 \text{ kg} \cdot \text{m}^2/\text{s}}$$

**Problem 10.2**

$$\omega_p = \frac{C}{A-C} \frac{\omega_s}{\cos\theta} = \frac{500}{300-500} \frac{6}{\cos 10^\circ} = -15.06 \text{ rad/s}$$

$$T = \frac{2\pi}{|\omega_p|} = \frac{2\pi}{15.06} = \underline{0.4173 \text{ s}}$$

**Problem 10.3**

$$\omega_p = \frac{C}{A-C} \frac{\omega_s}{\cos\theta} = \frac{mr^2}{\frac{1}{2}mr^2 - mr^2} \frac{\omega_s}{\cos\theta} = -2 \frac{\omega_s}{\cos\theta}$$

$$\cos\theta = 1 - \frac{\theta^2}{2}$$

$$\frac{1}{\cos\theta} = \left(1 - \frac{\theta^2}{2}\right)^{-1} = 1 + \frac{\theta^2}{2} \quad (\theta \ll 0)$$

$$\therefore \omega_p = -2\omega_s \left(1 + \frac{\theta^2}{2}\right)$$

**Problem 10.4**

$$H = A\omega_p = 1000 \cdot 2 = \underline{2000 \text{ kg} \cdot \text{m}^2/\text{s}}$$

**Problem 10.5**

$$\dot{\mathbf{H}}_G \Big|_{rel} + \boldsymbol{\omega} \times \mathbf{H}_G = 0$$

$$[\mathbf{I}_G] \{\boldsymbol{\alpha}\} + \boldsymbol{\omega} \times \mathbf{H}_G = 0$$

$$\begin{bmatrix} 385.4 & 0 & 0 \\ 0 & 416.7 & 0 \\ 0 & 0 & 52.08 \end{bmatrix} \{\boldsymbol{\alpha}\} + \begin{bmatrix} 0.01 \\ -0.03 \\ 0.02 \end{bmatrix} \times \begin{bmatrix} 385.4 & 0 & 0 \\ 0 & 416.7 & 0 \\ 0 & 0 & 52.08 \end{bmatrix} \begin{bmatrix} 0.01 \\ -0.03 \\ 0.02 \end{bmatrix} = \begin{bmatrix} 0 \\ 0 \\ 0 \end{bmatrix}$$

$$\begin{bmatrix} 385.4 & 0 & 0 \\ 0 & 416.7 & 0 \\ 0 & 0 & 52.08 \end{bmatrix} \{\boldsymbol{\alpha}\} + \begin{bmatrix} 0.01 \\ -0.03 \\ 0.02 \end{bmatrix} \times \begin{bmatrix} 3.854 \\ -12.50 \\ 1.042 \end{bmatrix} = \begin{bmatrix} 0 \\ 0 \\ 0 \end{bmatrix}$$

$$\begin{bmatrix} 385.4 & 0 & 0 \\ 0 & 416.7 & 0 \\ 0 & 0 & 52.08 \end{bmatrix} \{\boldsymbol{\alpha}\} + \begin{bmatrix} 0.2188 \\ 0.0666 \\ -0.00939 \end{bmatrix} = \begin{bmatrix} 0 \\ 0 \\ 0 \end{bmatrix}$$

$$\begin{bmatrix} 385.4 & 0 & 0 \\ 0 & 416.7 & 0 \\ 0 & 0 & 52.08 \end{bmatrix} \{\boldsymbol{\alpha}\} + \begin{bmatrix} 0.2188 \\ 0.0666 \\ -0.00939 \end{bmatrix} = \begin{bmatrix} 0 \\ 0 \\ 0 \end{bmatrix}$$

$$\{\boldsymbol{\alpha}\} = - \begin{bmatrix} 385.4 & 0 & 0 \\ 0 & 416.7 & 0 \\ 0 & 0 & 52.08 \end{bmatrix}^{-1} \begin{bmatrix} 0.2188 \\ 0.0666 \\ -0.00939 \end{bmatrix} = \begin{bmatrix} -0.0005676 \\ -0.00016 \\ 0.0001803 \end{bmatrix} \quad (\text{m/s}^2)$$

$$\|\boldsymbol{\alpha}\| = 0.0006167 \text{ m/s}^2$$

**Problem 10.6**

$$\omega_p = \frac{C}{C - A \cos \theta} \omega_s = \frac{0.72}{0.72 - 0.36} \frac{30}{\cos 15^\circ} = -62.12 \text{ rad/s}$$

$$\omega_n = 0$$

$$\omega_x = \omega_p \sin \theta \sin \psi + \omega_n \cos \psi = -62.12 \sin 15^\circ \sin \psi + 0 \cdot \cos \psi = -16.08 \sin \psi$$

$$\omega_y = \omega_p \sin \theta \cos \psi - \omega_n \cos \psi = -62.12 \sin 15^\circ \cos \psi - 0 \cdot \cos \psi = -16.08 \cos \psi$$

$$\omega_z = \omega_s + \omega_p \cos \theta = 30 + (-62.12) \cos 15^\circ = -30$$

$$T_R = \frac{1}{2} (A\omega_x^2 + B\omega_y^2 + C\omega_z^2)$$

$$= \frac{1}{2} [0.36(-16.08 \sin \psi)^2 + 0.36(-16.08 \cos \psi)^2 + 0.72(-30)^2]$$

$$= \frac{1}{2} [93.05(\sin^2 \psi + \cos^2 \psi) + 648]$$

$$= \frac{1}{2} (93.05 + 648)$$

$$= \underline{370.5 \text{ J}}$$

Or,

$$H = A\omega_p = 0.36(-62.12) = -22.36 \text{ kg} \cdot \text{m}^2 / \text{s}$$

$$T_R = \frac{1}{2} \frac{H^2}{C} \left( 1 + \frac{C - A}{A} \sin^2 \theta \right)$$

$$= \frac{1}{2} \frac{(-22.36)^2}{0.72} \left( 1 + \frac{0.72 - 0.36}{0.36} \sin^2 15^\circ \right)$$

$$= \frac{1}{2} \cdot 694.5 \cdot (1 + 0.06699)$$

$$= \underline{370.5 \text{ J}}$$

**Problem 10.7**

$$[\mathbf{I}_G] = \begin{bmatrix} \frac{1}{12} m [l^2 + (2l)^2] & 0 & 0 \\ 0 & \frac{1}{12} m [l^2 + (3l)^2] & 0 \\ 0 & 0 & \frac{1}{12} m [(2l)^2 + (3l)^2] \end{bmatrix} = \begin{bmatrix} \frac{5}{12} ml^2 & 0 & 0 \\ 0 & \frac{5}{6} ml^2 & 0 \\ 0 & 0 & \frac{13}{12} ml^2 \end{bmatrix}$$

$$\{\mathbf{H}_0\} = [\mathbf{I}_G] \{\boldsymbol{\omega}\} = \begin{bmatrix} \frac{5}{12} ml^2 & 0 & 0 \\ 0 & \frac{5}{6} ml^2 & 0 \\ 0 & 0 & \frac{13}{12} ml^2 \end{bmatrix} \begin{bmatrix} 1.5\omega_0 \\ 0.8\omega_0 \\ 0.6\omega_0 \end{bmatrix} = \begin{bmatrix} 0.625 ml^2 \omega_0 \\ 0.6667 ml^2 \omega_0 \\ 0.65 ml^2 \omega_0 \end{bmatrix}$$

$$H_0 = 1.121 ml^2 \omega_0$$

$$T_0 = \frac{1}{2} \boldsymbol{\omega} \cdot \mathbf{H}_0 = \frac{1}{2} \begin{bmatrix} 1.5\omega_0 & 0.8\omega_0 & 0.6\omega_0 \end{bmatrix} \begin{Bmatrix} 0.625ml^2\omega_0 \\ 0.6667ml^2\omega_0 \\ 0.65ml^2\omega_0 \end{Bmatrix} = 0.9305ml^2\omega_0^2$$

(a)

$$T = \frac{1}{2} C \omega^2 = \frac{1}{2} \frac{13}{12} ml^2 \omega^2 = 0.5417ml^2 \omega^2$$

$$T = T_0$$

$$0.5417ml^2 \omega^2 = 0.9305ml^2 \omega_0^2$$

$$\omega = \sqrt{1.718} \omega_0 = \underline{1.311\omega_0}$$

(b)

$$H = C\omega = \frac{13}{12} ml^2 \omega$$

$$H = H_0$$

$$\frac{13}{12} ml^2 \omega = 1.121ml^2 \omega_0$$

$$\omega = \underline{1.035\omega_0}$$

**Problem 10.8**

$$H_{initial} = 1000 \cdot 6 = 6000 \text{ kg} \cdot \text{m}^2 / \text{s}$$

$$T_{initial} = \frac{1}{2} \cdot 1000 \cdot 6^2 = 18000 \text{ kg} \cdot \text{m}^2 / \text{s}^2$$

$$H_{final} = 5000\omega_{final}$$

$$H_{final} = H_{initial}$$

$$5000\omega_{final} = 6000$$

$$\omega_{final} = 1.2 \text{ rad/s}$$

$$T_{final} = \frac{1}{2} \cdot 5000 \cdot \omega_{final}^2 = \frac{1}{2} \cdot 5000 \cdot 1.2^2 = 3600 \text{ kg} \cdot \text{m}^2 / \text{s}^2$$

$$\Delta T = T_{final} - T_{initial} = 3600 - 18000 = \underline{-14400 \text{ J}}$$

**Problem 10.9**

$$\{\mathbf{H}_{G_0}\} = \begin{bmatrix} 0.1522 & -0.03975 & 0.012 \\ -0.03975 & 0.07177 & 0.04057 \\ 0.012 & 0.04057 & 0.1569 \end{bmatrix} \begin{Bmatrix} 10 \\ 0 \\ 0 \end{Bmatrix} = \begin{Bmatrix} 1.522 \\ -0.3975 \\ 0.1200 \end{Bmatrix} \text{ (kg} \cdot \text{m}^2 / \text{s)}$$

$$H_{G_0} = \|\mathbf{H}_{G_0}\| = 1.5776 \text{ kg} \cdot \text{m}^2 / \text{s}$$

$$T_0 = \frac{1}{2} \mathbf{H}_{G_0} \cdot \boldsymbol{\omega}_0 = \frac{1}{2} \begin{bmatrix} 1.522 & -0.3975 & 0.1200 \end{bmatrix} \begin{Bmatrix} 10 \\ 0 \\ 0 \end{Bmatrix} = 7.610 \text{ J}$$

$$I_{\max} = 0.1747 \text{ kg} \cdot \text{m}^2 \quad (\text{from Example 10.11})$$

$$H_{G_f} = I_{\max} \omega_f = 0.1747 \omega_f$$

$$H_{G_f} = H_{G_0}$$

$$0.1747 \omega_f = 1.578$$

$$\omega_f = 9.03 \text{ rad/s}$$



$$T_f = \frac{1}{2} \cdot I_{\max} \omega_f^2 = \frac{1}{2} \cdot 0.1747 \cdot 9.03^2 = 7.123 \text{ J}$$

$$\Delta T = T_f - T_0 = 7.123 - 7.610 = \underline{-0.4867 \text{ J}}$$

**Problem 10.10**

$$C_r \omega_2^{(r)} + C_p (\omega_2^{(r)} + \omega_{rel2}^{(p)}) = C_r \omega_1^{(r)} + C_p (\omega_1^{(r)} + \omega_{rel1}^{(p)})$$

$$\omega_2^{(r)} = \omega_1^{(r)} + \frac{C_p (\omega_{rel1}^{(p)} - \omega_{rel2}^{(p)})}{C_p + C_r}$$

$$\omega_2^{(r)} = 3 + \frac{500(1 - 0.5)}{500 + 1000} = \underline{3.167 \text{ rad/s}}$$

**Problem 10.11**

$$\omega_p = \frac{C}{A - C \cos \theta} \omega_s = \frac{1000}{5000 - 1000 \cos 20^\circ} \cdot 0.1 = 0.0266 \text{ rad/s}$$

$$t = \frac{\pi}{\omega_p} = \frac{\pi}{0.0266} = \underline{118.1 \text{ s}}$$

**Problem 10.12**

$$\cos \gamma = \frac{A}{\sqrt{A^2 + C^2 \tan^2 \frac{\phi}{2}}}$$

$$A = \frac{m}{12} (3r^2 + l^2) = \frac{500}{12} (3 \cdot 0.5^2 + 2^2) = 197.9 \text{ kg} \cdot \text{m}^2 \quad C = \frac{1}{2} m r^2 = \frac{1}{2} 500 \cdot 0.5^2 = 62.5 \text{ kg} \cdot \text{m}^2$$

$$\phi = 2 \tan^{-1} \left[ \sqrt{\frac{\left(\frac{A}{\cos \gamma}\right)^2 - A^2}{C^2}} \right] = 2 \tan^{-1} \left[ \sqrt{\frac{\left(\frac{197.9}{\cos 5^\circ}\right)^2 - 197.9^2}{62.5^2}} \right] = \underline{30.97^\circ}$$

**Problem 10.13**

$$Npd = I(\omega_2 - \omega_1)$$

$$\omega_2 = \omega_1 + \frac{Npd}{I}$$

$$\omega_2 = 0.01 \cdot 2\pi + \frac{30 \cdot 15 \cdot 1.5}{2000} = 0.4003 \text{ rad/s} = \underline{0.0637 \text{ rev/s}}$$

**Problem 10.14**

$$\mathbf{H}_{G0} = A\omega_{0x}\hat{\mathbf{i}} + B\omega_{0y}\hat{\mathbf{j}} + C\omega_{0z}\hat{\mathbf{k}}$$

$$= 2000 \cdot 0.1\hat{\mathbf{i}} + 4000 \cdot 0.3\hat{\mathbf{j}} + 6000 \cdot 0.5\hat{\mathbf{k}}$$

$$= 200\hat{\mathbf{i}} + 1200\hat{\mathbf{j}} + 3000\hat{\mathbf{k}}$$

$$\mathbf{H}_G = \mathbf{H}_{G0} + \Delta\mathbf{H}_G$$

$$= 200\hat{\mathbf{i}} + 1200\hat{\mathbf{j}} + 3000\hat{\mathbf{k}} + (50\hat{\mathbf{i}} - 100\hat{\mathbf{j}} + 300\hat{\mathbf{k}})$$

$$= 250\hat{\mathbf{i}} + 1100\hat{\mathbf{j}} + 3300\hat{\mathbf{k}}$$

$$A\omega_x \hat{\mathbf{i}} + B\omega_y \hat{\mathbf{j}} + C\omega_z \hat{\mathbf{k}} = 250\hat{\mathbf{i}} + 1100\hat{\mathbf{j}} + 3300\hat{\mathbf{k}}$$

$$\omega_x = \frac{250}{A} = \frac{250}{2000} = 0.125 \text{ rad/s}$$

$$\omega_y = \frac{1100}{B} = \frac{1100}{4000} = 0.275 \text{ rad/s}$$

$$\omega_z = \frac{3300}{C} = \frac{3300}{6000} = 0.55 \text{ rad/s}$$

$$\omega = \sqrt{\omega_x^2 + \omega_y^2 + \omega_z^2} = \underline{0.6275 \text{ rad/s}}$$

**Problem 10.15**

$$A = \frac{1}{4}mr^2 + \frac{1}{12}ml^2 = \frac{1}{4}300 \cdot 1.5^2 + \frac{1}{12}300 \cdot 1.5^2 = 225 \text{ kg} \cdot \text{m}^2$$

$$C = \frac{1}{2}mr^2 = \frac{1}{2}300 \cdot 1.5^2 = 337.5 \text{ kg} \cdot \text{m}^2$$

$$\mathbf{H}_{G_1} = C\omega_1 \hat{\mathbf{k}} = 337.5 \cdot \left(1 \cdot \frac{2\pi}{60} \hat{\mathbf{k}}\right) = 35.34\hat{\mathbf{k}} \text{ (kg} \cdot \text{m}^2)$$

$$\mathbf{H}_{G_2} = \mathbf{H}_{G_1} + \bar{\mathcal{I}}_M$$

$$\mathbf{H}_{G_2} = 35.34\hat{\mathbf{k}} + (-\mathcal{I}_M \hat{\mathbf{i}})$$

$$H_{G_2} = \sqrt{35.34^2 + \mathcal{I}_M^2} = \sqrt{1249 + \mathcal{I}_M^2}$$

$$H_{G_2} = A\omega_p$$

$$\sqrt{1249 + \mathcal{I}_M^2} = 225 \cdot (0.1 \cdot 2\pi) = 141.4$$

$$\mathcal{I}_M^2 = 18740$$

$$\mathcal{I}_M = \underline{136.9 \text{ N} \cdot \text{m} \cdot \text{s}}$$

**Problem 10.16**

$$K = 1 + \frac{C}{2mR^2} = 1 + \frac{300}{2 \cdot 3 \cdot 1.5^2} = 23.22$$

(a)

$$l_f = R \sqrt{K \frac{\omega_0 - \omega_f}{\omega_0 + \omega_f}} = 1.5 \sqrt{23.22 \cdot \frac{5-1}{5+1}} = \underline{5.902 \text{ m}}$$

$$t = \sqrt{\frac{K}{\omega_0^2} \frac{\omega_0 - \omega_f}{\omega_0 + \omega_f}} = \sqrt{\frac{23.22}{5^2} \frac{5-1}{5+1}} = \underline{0.7869 \text{ s}}$$

(b)

$$l_f = R \sqrt{K \frac{\omega_0 - \omega_f}{\omega_0 + \omega_f}} = 1.5 \sqrt{23.22 \cdot \frac{5-0}{5+0}} = \underline{7.228 \text{ m}}$$

$$t = \sqrt{\frac{K}{\omega_0^2} \frac{\omega_0 - \omega_f}{\omega_0 + \omega_f}} = \sqrt{\frac{23.22}{5^2} \frac{5-0}{5+0}} = \underline{0.9636 \text{ s}}$$

**Problem 10.17**

$$T_0 = \frac{1}{2}A(\omega_x^2 + \omega_y^2) + \frac{1}{2}C\omega_z^2 = \frac{1}{2}A\Omega^2 + \frac{1}{2}C\omega_0^2$$

$$\omega_p = \frac{C}{A-C} \frac{\omega_s}{\cos\theta} = \frac{60}{30-60} \frac{2}{\cos 15^\circ} = -4.141 \text{ rad/s}$$

$$\omega_0 = \frac{A}{C} \omega_p \cos\theta = \frac{30}{60} (-4.141) \cos 15^\circ = -2 \text{ rad/s}$$

$$\Omega = \omega_p \sin\theta = -4.141 \sin 15^\circ = -1.072 \text{ rad/s}$$

$$\therefore T_0 = \frac{1}{2} \cdot 30 (-1.072)^2 + \frac{1}{2} \cdot 60 (-2)^2 = 137.2 \text{ J}$$

(a)

$$H_0 = |A\omega_p| = 30 \cdot 4.141 = 124.2 \text{ kg} \cdot \text{m}^2/\text{s}$$

$$H_f = H_0$$

$$60\omega_f = 124.2 \Rightarrow \omega_f = 2.071 \text{ rad/s}$$

(b)

$$T_f = \frac{1}{2}C\omega_f^2 = \frac{1}{2} \cdot 60 \cdot 2.071^2 = 128.6 \text{ J}$$

$$\Delta T = T_f - T_0 = 128.6 - 137.2 = -8.616 \text{ J}$$

(c)

$$l_f = R \sqrt{1 + \frac{C}{2mR^2}} = 1 \cdot \sqrt{1 + \frac{60}{2 \cdot 7 \cdot 1^2}} = 2.299 \text{ m}$$

**Problem 10.18**

$$\{\mathbf{H}_G\} = [\mathbf{I}_G]\{\boldsymbol{\omega}\} = \begin{bmatrix} A & 0 & 0 \\ 0 & A & 0 \\ 0 & 0 & C \end{bmatrix} \begin{Bmatrix} 0 \\ n \\ -\omega_s \end{Bmatrix} = \begin{Bmatrix} 0 \\ nA \\ -\omega_s C \end{Bmatrix}$$

$$\mathbf{M}_G = \boldsymbol{\Omega} \times \mathbf{H}_G = \begin{vmatrix} \hat{\mathbf{i}} & \hat{\mathbf{j}} & \hat{\mathbf{k}} \\ 0 & n & 0 \\ 0 & nA & -\omega_s C \end{vmatrix} = -C\omega_s n \hat{\mathbf{i}}$$

$$\omega_s = 1 \cdot \frac{2\pi}{60} = 0.1047 \text{ rad/s}$$

$$n = \frac{2\pi + \frac{2\pi}{365.26}}{24 \cdot 3600} = 7.292 \times 10^{-5} \text{ rad/s}$$

$$C = 550 \text{ kg} \cdot \text{m}^2$$

$$\therefore M_{G_x} = -550 \cdot 0.1047 \cdot 7.292 \times 10^{-5} = -0.0042 \text{ N} \cdot \text{m}$$

**Problem 10.19**  $\boldsymbol{\omega}_0$  and  $\boldsymbol{\omega}_f$  are the initial and final angular velocities of the spacecraft.  $\boldsymbol{\omega}$  is the angular velocity of the flywheel relative to the vehicle.

$$[\mathbf{H}_G^{(v)} + \mathbf{H}_G^{(w)}]_0 = [\mathbf{H}_G^{(v)} + \mathbf{H}^{(w)}]_f$$

$$\begin{aligned} & (A\omega_{0x}\hat{\mathbf{i}} + A\omega_{0y}\hat{\mathbf{j}} + C\omega_{0z}\hat{\mathbf{k}}) + (I_x\omega_{0x}\hat{\mathbf{i}} + I_y\omega_{0y}\hat{\mathbf{j}} + I_z\omega_{0z}\hat{\mathbf{k}}) \\ &= (A\omega_x\hat{\mathbf{i}} + A\omega_y\hat{\mathbf{j}} + C\omega_z\hat{\mathbf{k}}) + [I_x(\omega_x + \omega)\hat{\mathbf{i}} + I_y\omega_y\hat{\mathbf{j}} + I_z\omega_z\hat{\mathbf{k}}] \end{aligned}$$

$$\begin{aligned}(A + I_z)\omega_z &= (A + I_z)\omega_{0z} \Rightarrow \omega_z = \omega_{0z} = 0 \\ (A + I_y)\omega_y &= (A + I_y)\omega_{0y} \Rightarrow \omega_y = \omega_{0y} = 0.05 \text{ rad/s}\end{aligned}$$

$$(A + I_x)\omega_x + I_x\omega = (A + I_x)\omega_{0x} \Rightarrow \omega = \left(1 + \frac{A}{I_x}\right)(\omega_{0x} - \omega_x)$$

$$\therefore \omega = \left(1 + \frac{1000}{20}\right)(0.1 - 0.003) = \underline{4.947 \text{ rad/s}}$$

---

**Problem 10.20**

Given:  $I_3 > I_2 > I_1$ .

Figure 10.29, Stable region I:  $I_{roll} > I_{yaw} > I_{pitch}$ :

- $I_1$  axis in pitch direction (normal to orbital plane)
- $I_2$  axis in yaw direction (radial)
- $I_3$  axis in roll direction (local horizon)

Figure 10.29, Stable region II (preferred):  $I_{pitch} > I_{roll} > I_{yaw}$ :

- $I_1$  axis in yaw direction (radial)
  - $I_2$  axis in roll direction (local horizon)
  - $I_3$  axis in pitch direction (normal to orbital plane)
-



**Problem 11.1**

$$m_p = m_{p_{out}} + m_{p_{in}} = m_{p_{out}} + \frac{m_{p_{out}}}{4} = \frac{5}{4}m_{p_{out}}$$

Outbound leg:

$$\begin{aligned} \Delta v &= I_{sp} g_o \ln \left( \frac{m_e + m_p + m_{PL}}{m_e + m_p - m_{p_{out}} + m_{PL}} \right) \\ 4220 &= 430 \cdot 9.81 \cdot \ln \left( \frac{m_e + \frac{5}{4}m_{p_{out}} + 3500}{m_e + \frac{5}{4}m_{p_{out}} - m_{p_{out}} + 3500} \right) \\ &= 430 \cdot 9.81 \cdot \ln \left( \frac{m_e + \frac{5}{4}m_{p_{out}} + 3500}{m_e + \frac{1}{4}m_{p_{out}} + 3500} \right) \\ \frac{m_e + \frac{5}{4}m_{p_{out}} + 3500}{m_e + \frac{1}{4}m_{p_{out}} + 3500} &= 2.719 \\ 0.5702m_{p_{out}} - 1.719m_e &= 6018 \end{aligned} \tag{1}$$

Return from GEO to LEO:

$$\begin{aligned} \Delta v &= I_{sp} g_o \ln \left( \frac{m_e + \frac{1}{4}m_{p_{out}} + 3500}{m_e} \right) \\ 4220 &= 430 \cdot 9.81 \cdot \ln \left( \frac{m_e + \frac{1}{4}m_{p_{out}}}{m_e} \right) \\ \frac{m_e + \frac{1}{4}m_{p_{out}}}{m_e} &= 2.719 \\ m_{p_{out}} &= 6.876m_e \end{aligned} \tag{2}$$

Substitute (2) into(1):

$$\begin{aligned} 0.5702(6.876m_e) - 1.719m_e &= 6018 \\ m_e &= 2733 \text{ kg} \end{aligned}$$

---

**Problem 11.2**

First stage:

$$\begin{aligned} c &= I_{sp} g_o = 235 \cdot 9.81 = 2943 \text{ m/s} \\ v_{bo} &= c \ln \left( \frac{m_0}{m_f} \right) - \frac{(m_0 - m_f) g_o}{\mathfrak{M}_e} = 2943 \ln \left( \frac{249.5}{170.1} \right) - \frac{(249.5 - 170.1) \cdot 9.81}{10.61} = 1127 - 73.38 = 1054 \text{ m/s} \\ h_{bo} &= \frac{c}{\mathfrak{M}_e} \left[ \ln \left( \frac{m_f}{m_0} \right) m_f + m_0 - m_f \right] - \frac{1}{2} \left( \frac{m_0 - m_f}{\mathfrak{M}_e} \right)^2 g_o \\ &= \frac{2943}{10.61} \left[ \ln \left( \frac{170.1}{249.5} \right) \cdot 170.1 + 249.5 - 170.1 \right] - \frac{1}{2} \left( \frac{249.5 - 170.1}{10.61} \right)^2 \cdot 9.81 \end{aligned}$$

$$= 3947 - 274.4$$

$$= 3673 \text{ m}$$

After 3 second staging delay:

$$v = v_{bo} - g\Delta t_s = 1054 - 9.81 \cdot 3 = 1024 \text{ m/s}$$

$$h = h_{bo} + v_{bo}\Delta t_s - \frac{1}{2}g\Delta t_s^2 = 3673 + 1054 \cdot 3 - \frac{1}{2} \cdot 9.81 \cdot 3^2 = 3673 + 3117 = 6790 \text{ m}$$

Second stage:

$$v_0 = 1024 \text{ m/s}$$

$$h_0 = 6790 \text{ m}$$

$$c = I_{sp}g_0 = 235 \cdot 9.81 = 2305 \text{ m/s}$$

$$v_{bo} = v_0 + c \ln\left(\frac{m_0}{m_f}\right) - \frac{(m_0 - m_f)g_0}{m_e}$$

$$= 1024 + 2305 \ln\left(\frac{113.4}{58.97}\right) - \frac{(113.4 - 58.97) \cdot 9.81}{4.0573}$$

$$= 1024 + 1508 - 131.7$$

$$= 2400 \text{ m/s}$$

$$h_{bo} = h_0 + v_0 \left(\frac{m_0 - m_f}{m_e}\right) + \frac{c}{m_e} \left[ \ln\left(\frac{m_f}{m_0}\right) m_f + m_0 - m_f \right] - \frac{1}{2} \left(\frac{m_0 - m_f}{m_e}\right)^2 g_0$$

$$= 6790 + 1024 \left(\frac{113.4 - 59.97}{4.053}\right) + \frac{2305}{4.053} \left[ \ln\left(\frac{59.97}{113.4}\right) \cdot 58.97 + 113.4 - 58.97 \right] - \frac{1}{2} \left(\frac{113.4 - 58.97}{4.063}\right)^2 \cdot 9.81$$

$$= 6790 + 13760 + 9028 - 884.7$$

$$= 28690 \text{ m}$$

Coast to apogee:

$$v_0 = 2400 \text{ m/s}$$

$$h_0 = 28690 \text{ m}$$

$$0 = v_0 - gt_{\max} \Rightarrow t_{\max} = \frac{v_0}{g} = \frac{2400}{9.81} = 244.7 \text{ s}$$

$$h_{\max} = h_0 + v_0 t_{\max} - \frac{1}{2} g t_{\max}^2 = 28690 + 2400 \cdot 244.7 - \frac{1}{2} \cdot 9.81 \cdot 244.7^2 = \underline{322300 \text{ m}}$$

### Problem 11.3

$$v_0 = \omega_{\text{earth}} R_{\text{earth}} \cos \phi = 7.292(10^{-5}) \cdot 6378 \cdot \cos 28^\circ = 0.4107 \text{ km/s}$$

$$\Delta v = \sqrt{\frac{398600}{6678}} + 2 - 0.4107 = 9.315 \text{ km/s}$$

$$v_{bo} = \Delta v = 9.315 \text{ km/s}$$

$$v_{bo} = v_{bo1} + v_{bo2}$$

$$v_{bo} = I_{sp1} g_0 \ln\left(\frac{m_{01}}{m_{f1}}\right) + I_{sp2} g_0 \ln\left(\frac{m_{02}}{m_{f2}}\right)$$

$$9315 = 290 \cdot 9.81 \cdot \ln\left(\frac{2 \cdot 525000 + 30000 + 600000 + m_{PL}}{2 \cdot (525000 - 450000) + 3000 + 600000 + m_{PL}}\right) \\ + 450 \cdot 9.81 \cdot \ln\left(\frac{30000 + 600000 + m_{PL}}{30000 + m_{PL}}\right) \\ 9315 = 2845 \cdot \ln\left(\frac{1680000 + m_{PL}}{753000 + m_{PL}}\right) + 4414 \cdot \ln\left(\frac{630000 + m_{PL}}{30000 + m_{PL}}\right)$$

To find the value of  $m_{PL}$  satisfying this equation, graph the function

$$f = 9315 - 2845 \cdot \ln\left(\frac{1680000 + m_{PL}}{753000 + m_{PL}}\right) - 4414 \cdot \ln\left(\frac{630000 + m_{PL}}{30000 + m_{PL}}\right)$$

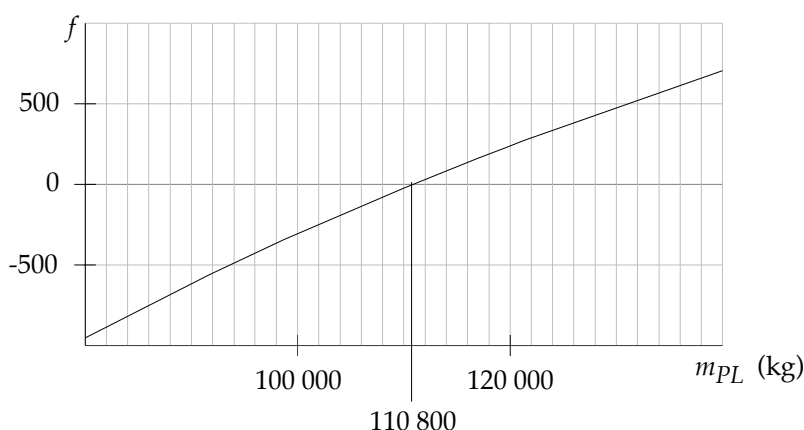

$f = 0$  when  $m_{PL} = 110800$  kg

### Problem 11.4

$$\pi_{PL} = \frac{m_{PL}}{m_0} = \frac{10000}{150000} = 0.06667$$

$$\lambda = \frac{\pi_{PL}^{1/3}}{1 - \pi_{PL}^{1/3}} = 0.682$$

$$\varepsilon = \frac{m_E}{m_0 - m_{PL}} = \frac{20000}{150000 - 10000} = 0.1429$$

(a)

$$n = \frac{1 + \lambda}{\varepsilon + \lambda} = \frac{1 + 0.682}{0.1429 + 0.682} = 2.039$$

$$\Delta v = I_{sp} g_0 \ln n^3 = 310 \cdot 0.00981 \cdot \ln 2.039^3 = 6.5 \text{ km/s}$$

(b)

$$m_{p1} = \frac{(1 - \pi_{PL}^{1/3})(1 - \varepsilon)}{\pi_{PL}} m_{PL} = \frac{(1 - 0.06667^{1/3})(1 - 0.1429)}{0.06667} \cdot 10000 = 76440 \text{ kg}$$

$$m_{p2} = \frac{(1 - \pi_{PL}^{1/3})(1 - \varepsilon)}{\pi_{PL}^{2/3}} m_{PL} = \frac{(1 - 0.06667^{1/3})(1 - 0.1429)}{0.06667^{2/3}} \cdot 10000 = 30990 \text{ kg}$$

$$m_{p3} = \frac{(1 - \pi_{PL}^{1/3})(1 - \varepsilon)}{\pi_{PL}^{1/3}} m_{PL} = \frac{(1 - 0.06667^{1/3})(1 - 0.1429)}{0.06667^{1/3}} \cdot 10000 = 12570 \text{ kg}$$



(c)

$$m_{E1} = \frac{(1 - \pi_{PL}^{1/3})\varepsilon}{\pi_{PL}} m_{PL} = \frac{(1 - 0.06667^{1/3}) \cdot 0.1429}{0.06667} 10\,000 = \underline{12\,740 \text{ kg}}$$

$$m_{E2} = \frac{(1 - \pi_{PL}^{1/3})\varepsilon}{\pi_{PL}^{2/3}} m_{PL} = \frac{(1 - 0.06667^{1/3}) \cdot 0.1429}{0.06667^{2/3}} 10\,000 = \underline{5\,166 \text{ kg}}$$

$$m_{E3} = \frac{(1 - \pi_{PL}^{1/3})\varepsilon}{\pi_{PL}^{1/3}} m_{PL} = \frac{(1 - 0.06667^{1/3}) \cdot 0.1429}{0.06667^{1/3}} 10\,000 = \underline{2\,095 \text{ kg}}$$

(d)

$$m_{03} = m_{E3} + m_{p3} + m_{PL} = 2\,095 + 12\,570 + 10\,000 = \underline{24\,660 \text{ kg}}$$

$$m_{02} = m_{E2} + m_{p2} + m_{03} = 5\,166 + 30\,990 + 24\,660 = \underline{60\,820 \text{ kg}}$$

$$m_{01} = m_{E1} + m_{p1} + m_{02} = 12\,740 + 76\,440 + 60\,820 = \underline{150\,000 \text{ kg}}$$

**Problem 11.5**

$$c_1 = I_{sp1} g_0 = 300 \cdot 0.00981 = 2.943 \text{ km/s}$$

$$c_2 = I_{sp2} g_0 = 235 \cdot 0.00981 = 2.305 \text{ km/s}$$

$$\varepsilon_1 = 0.2$$

$$\varepsilon_2 = 0.3$$

$$v_{bo} = 6.2 \text{ km/s}$$

$$v_{bo} = \sum_{i=1}^2 c_i \ln \left( \frac{c_i \eta - 1}{c_i \varepsilon_i \eta} \right) = c_1 \ln \left( \frac{c_1 \eta - 1}{c_1 \varepsilon_1 \eta} \right) + c_2 \ln \left( \frac{c_2 \eta - 1}{c_2 \varepsilon_2 \eta} \right)$$

$$6.2 = 2.943 \ln \left( \frac{2.943 \eta - 1}{2.943 \cdot 0.2 \eta} \right) + 2.305 \ln \left( \frac{2.305 \eta - 1}{2.305 \cdot 0.3 \eta} \right)$$

$$6.2 = 2.943 \ln \left( \frac{2.943 \eta - 1}{0.5886 \eta} \right) + 2.305 \ln \left( \frac{2.305 \eta - 1}{0.6915 \eta} \right)$$

To find  $\eta$ , graph the function

$$f = 2.943 \ln \left( \frac{2.943 \eta - 1}{0.5886 \eta} \right) + 2.305 \ln \left( \frac{2.305 \eta - 1}{0.6915 \eta} \right) - 6.2$$

As shown below,  $f = 0$  when  $\eta = 1.726$ .

$$n_1 = \frac{c_1 \eta - 1}{c_1 \varepsilon_1 \eta} = \frac{2.943 \cdot 1.726 - 1}{2.943 \cdot 0.2 \cdot 1.726} = 4.016$$

$$n_2 = \frac{c_2 \eta - 1}{c_2 \varepsilon_2 \eta} = \frac{2.305 \cdot 1.726 - 1}{2.305 \cdot 0.3 \cdot 1.726} = 2.496$$

$$m_2 = \frac{n_2 - 1}{1 - \varepsilon_2 n_2} m_{PL} = \frac{2.496 - 1}{1 - 0.3 \cdot 2.496} \cdot 10 = 59.53 \text{ kg}$$

$$m_1 = \frac{n_1 - 1}{1 - \varepsilon_1 n_1} (m_2 + m_{PL}) = \frac{4.016 - 1}{1 - 0.2 \cdot 4.016} (59.53 + 10) = 1065 \text{ kg}$$

$$M = m_1 + m_2 = 1065 + 59.53 = \underline{1124 \text{ kg}}$$

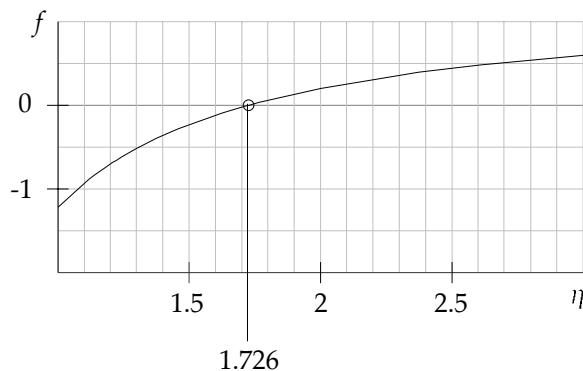
**Problem 11.6**

$$z = x^2 + y^2 + 2xy$$

$$g = x^2 - 2x + y^2$$

$$h = z + \lambda g = x^2 + y^2 + 2xy + \lambda(x^2 - 2x + y^2)$$

$$\frac{\partial h}{\partial x} = 2x + 2y + \lambda(2x - 2) = 0 \Rightarrow (\lambda + 1)x + y = \lambda$$

$$\frac{\partial h}{\partial y} = 2y + 2x + \lambda(2y) = 0 \Rightarrow x + (\lambda + 1)y = 0$$

$$\therefore \begin{bmatrix} \lambda + 1 & 1 \\ 1 & \lambda + 1 \end{bmatrix} \begin{Bmatrix} x \\ y \end{Bmatrix} = \begin{Bmatrix} \lambda \\ 0 \end{Bmatrix}$$

$$\begin{Bmatrix} x \\ y \end{Bmatrix} = \begin{bmatrix} \lambda + 1 & 1 \\ 1 & \lambda + 1 \end{bmatrix}^{-1} \begin{Bmatrix} \lambda \\ 0 \end{Bmatrix} = \frac{1}{\lambda(\lambda + 2)} \begin{bmatrix} \lambda + 1 & -1 \\ -1 & \lambda + 1 \end{bmatrix} \begin{Bmatrix} \lambda \\ 0 \end{Bmatrix} = \begin{Bmatrix} \frac{\lambda + 1}{\lambda + 2} \\ -\frac{1}{\lambda + 2} \end{Bmatrix}$$

$$x^2 - 2x + y^2 = 0$$

$$\frac{(\lambda + 1)^2}{(\lambda + 2)^2} - 2\frac{\lambda + 1}{\lambda + 2} + \frac{1}{(\lambda + 2)^2} = 0$$

Multiply through by  $(\lambda + 2)^2$  (this is okay since  $\lambda + 2 = 0$  clearly does not correspond to a local extremum). Then

$$(\lambda + 1)^2 - 2(\lambda + 1)(\lambda + 2) + 1 = 0$$

or

$$\lambda^2 + 4\lambda + 2 = 0$$

The two roots are  $-0.5858$  and  $-3.414$ .

$\lambda = -0.5858$ :

$$x = \frac{\lambda + 1}{\lambda + 2} = \frac{-0.5858 + 1}{-0.5858 + 2} = 0.2929$$

$$y = -\frac{1}{\lambda + 2} = -\frac{1}{-0.5858 + 2} = -0.7071$$

$$z_1 = x^2 + y^2 + 2xy = 0.2929^2 + (-0.7071)^2 + 2 \cdot 0.2929(-0.7071) = \underline{0.1716}$$

$\lambda = -3.414$ :

$$x = \frac{\lambda + 1}{\lambda + 2} = \frac{-3.414 + 1}{-3.414 + 2} = 1.707$$

$$y = -\frac{1}{\lambda + 2} = -\frac{1}{-3.414 + 2} = 0.7071$$

$$z_2 = x^2 + y^2 + 2xy = 1.707^2 + 0.7071^2 + 2 \cdot 1.707 \cdot 0.7071 = \underline{5.828}$$

Note that

$$d^2h = \left( \frac{\partial^2 z}{\partial x^2} + \lambda \frac{\partial^2 g}{\partial x^2} \right) dx^2 + 2 \left( \frac{\partial^2 z}{\partial x \partial y} + \lambda \frac{\partial^2 g}{\partial x \partial y} \right) dx dy + \left( \frac{\partial^2 z}{\partial y^2} + \lambda \frac{\partial^2 g}{\partial y^2} \right) dy^2$$

$$d^2h = (2 + \lambda \cdot 2) dx^2 + 2(2 + \lambda \cdot 0) dx dy + (2 + \lambda \cdot 2) dy^2$$

$$d^2h = 2(\lambda + 1)(dx^2 + dy^2) + 4 dx dy$$

For  $\lambda = -0.5858$ ,

$$\begin{aligned} d^2h &= 2(\lambda + 1)(dx^2 + dy^2) + 4 dx dy = 2(-0.5858 + 1)(dx^2 + dy^2) + 4 dx dy \\ &= 0.8284(dx^2 + dy^2) + 4 dx dy \end{aligned}$$

Since  $d^2h > 0$ ,  $z_1 = z_{\min}$ .

For  $\lambda = -3.414$ ,

$$\begin{aligned} d^2h &= 2(\lambda + 1)(dx^2 + dy^2) + 4 dx dy = 2(-3.414 + 1)(dx^2 + dy^2) + 4 dx dy \\ &= -4.828(dx^2 + dy^2) + 4 dx dy \end{aligned}$$

Since  $d^2h < 0$ ,  $z_2 = z_{\max}$ .

---