

**SPECIAL RELATIVITY**  
**reviewed and corrected**

**Jean DAVID**

**Copyright 2001**

## Introduction

In the purpose of his theory on relativity at the beginning of the last century, Albert Einstein suggested some original experiences called "mind games". These ones set up simple physical phenomenons (light propagation) in current life situations (a rolling train, a lift cabin moving up, and so on ...) for a large public comprehension.

His goal is to prove that the perception of every physical phenomenon depends on the location of the observer, his relation with others observers' referential particularly when those ones are moving in regard with his own.

The notion of absolute reference is cleared away as a conclusion of these little stories. Not only space has no more privileged landmark (since Galileo) but the notion of time as we used to know is completely changed. As a result, it is necessary to set up a mathematical formulation to transform coordinates between different referentials in order to preserve the constancy of basic physical laws (light speed, energy conservation, and so on.).

In this document, I would like to present the Einstein's famous experience which has given birth to the special relativity theory that is incessantly shown in every scientific document which deals about it.

Then, I will give you my new interpretation of this famous experience which will upset, I think, a well-established century-old theory.

Have a good reading and start your brain.

Jean DAVID  
2001, February

# Relativity by Einstein ( part 1 )

We suppose that the train is 300,000 km wide (1 second-light)

The train is moving at high speed  $V$  for exemple,  $c/3$  or 100 000 km/s

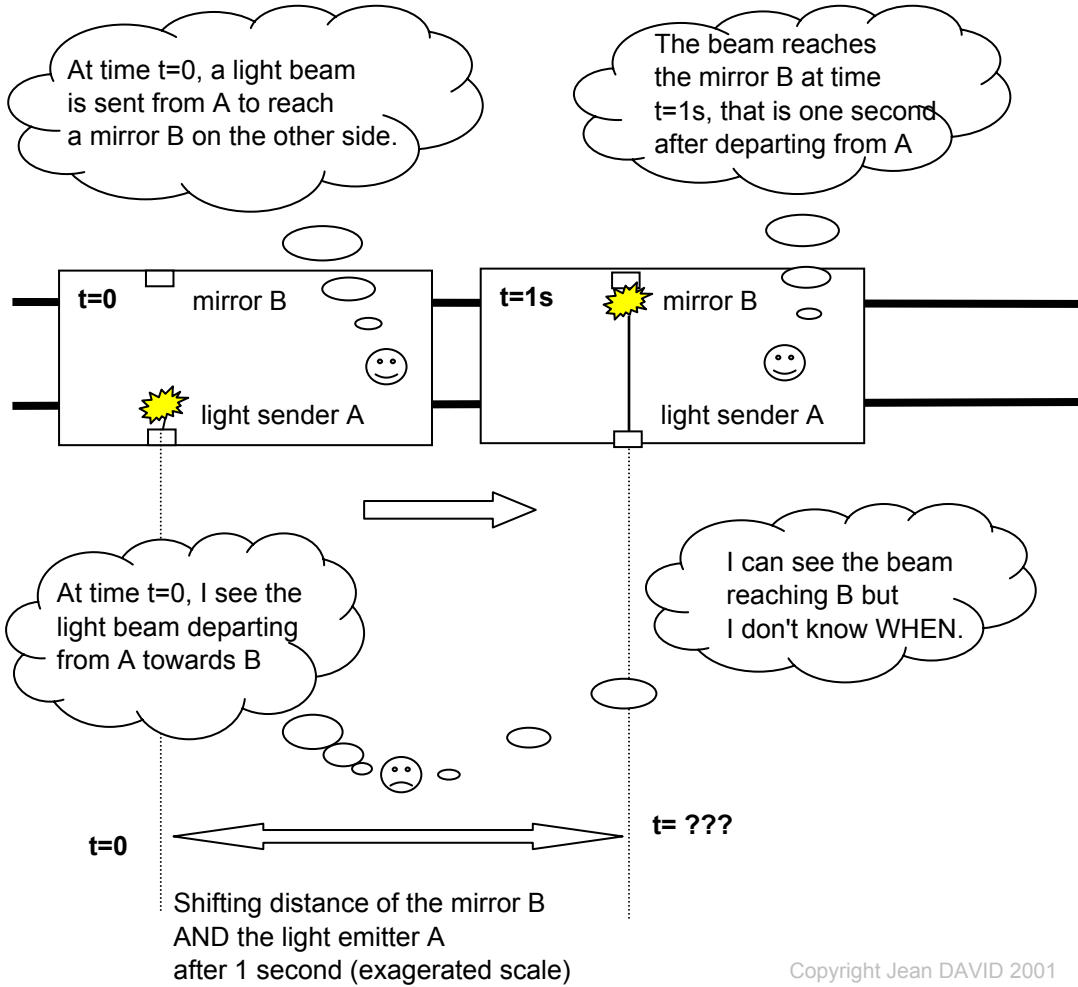

Copyright Jean DAVID 2001

## Relativity by Einstein ( part 2)

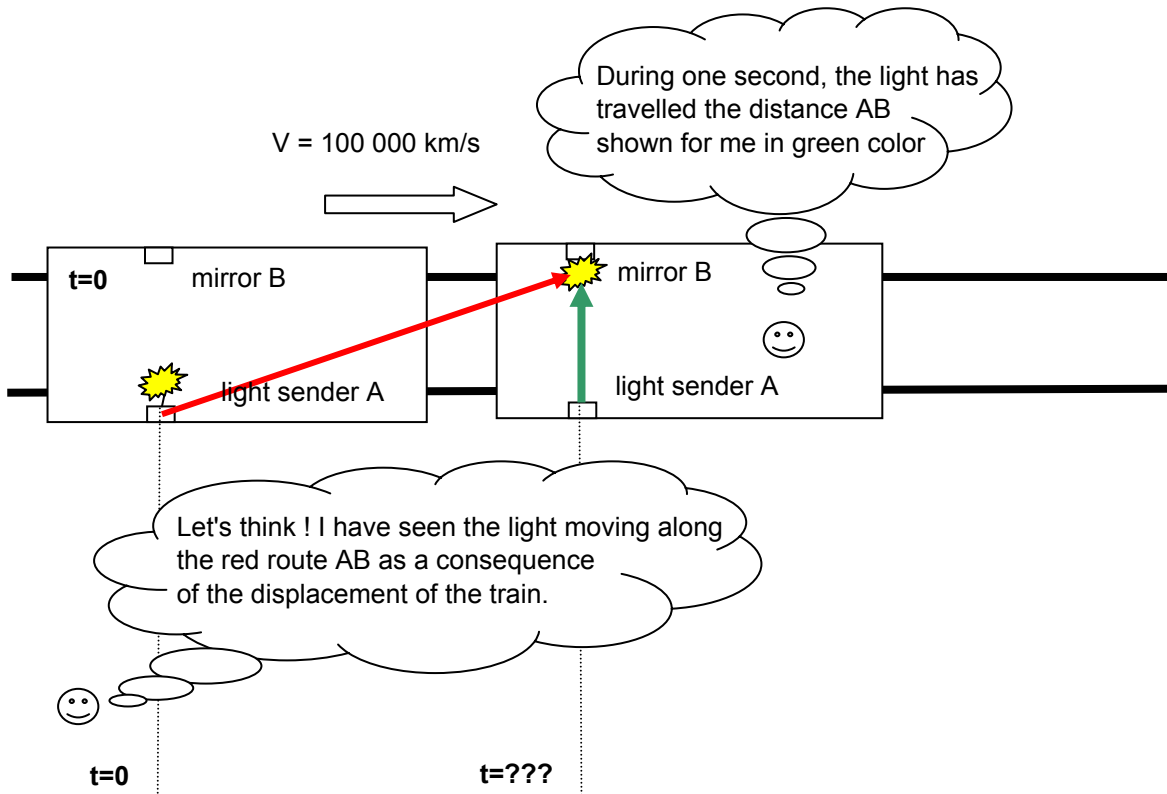

# Relativity by Einstein ( part 3 )

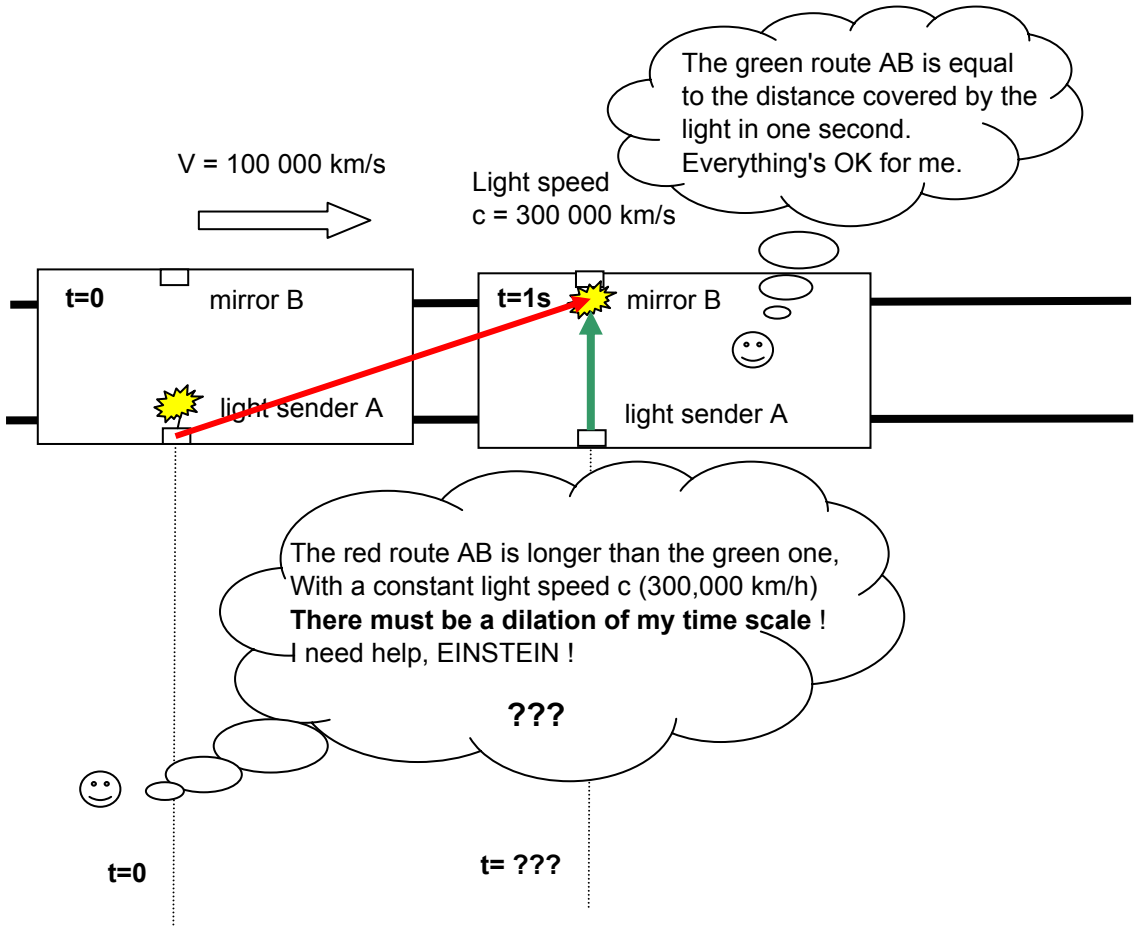

# Relativity by Einstein ( part 4 )

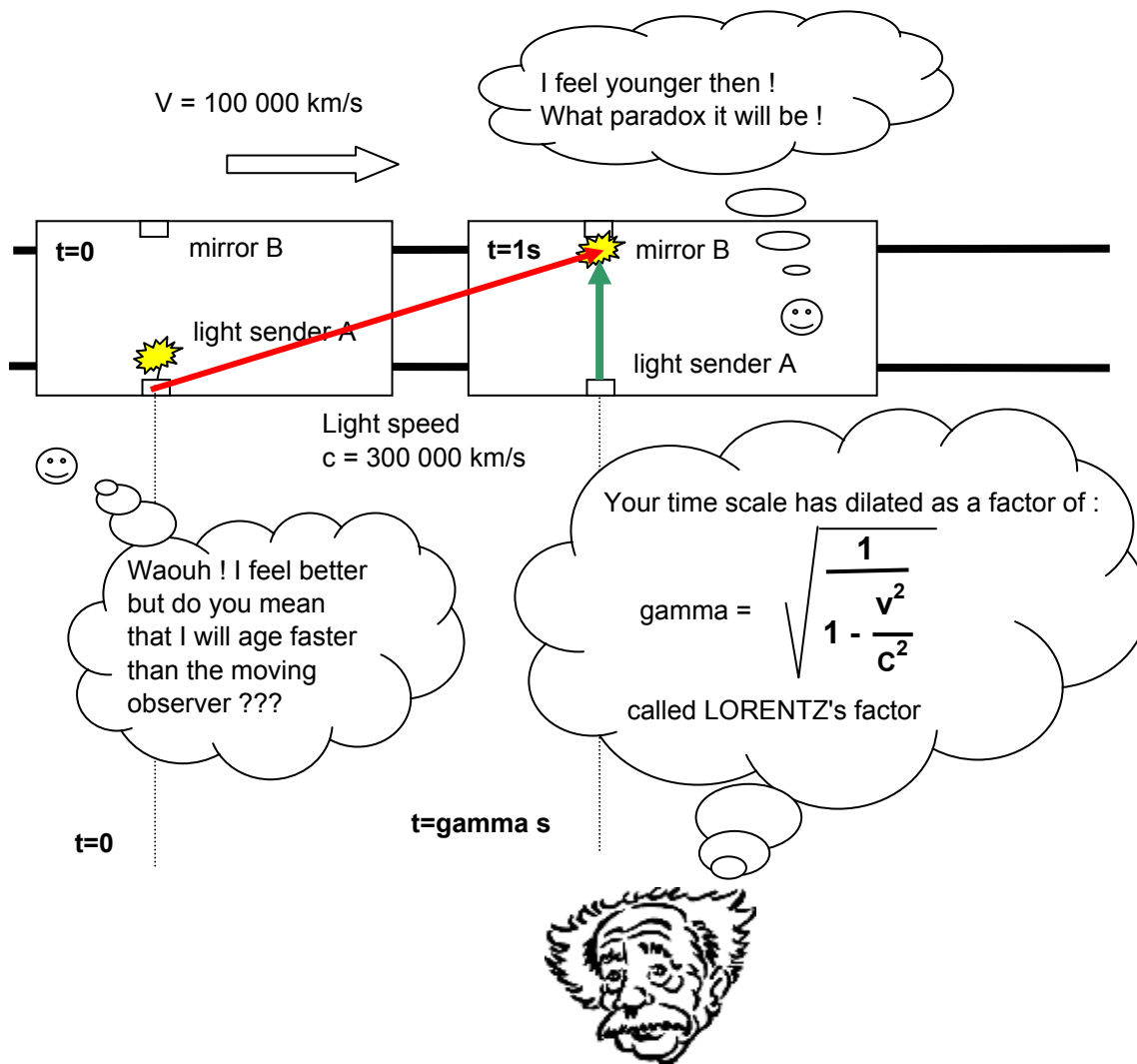

## **EINSTEIN's error**

The preceding interpretation by Einstein is based on a fundamental physical law, the constancy of light speed in vacuum and its limitation feature independently of the referential that is used.

Einstein had to introduce the notion of elastic space-time notion. In this medium, time, just like space, may be dilated or shrunk to cope with the results, leading to multiple paradoxes; the famous one is the Langevin's travelling twins.

The error about Einstein's conclusion, that I propose to correct in the following pages, is the fact that the thought experience did not respect the most important features about light propagation: its independence from the medium where it evolves but more important than all, the physical conditions of the object that has generated it.

Let me give you some precision. Once emitted, the light beam continue to travel at the same speed however the speed of the emitter is but over all, in the unique direction pointed at at the very moment the beam is emitted. It should continue this way as far as it does not interact on its way with any particle of matter.

Let there be the rules.

I invite you to do once again with me the famous experience.

Are you ready ?

# Relativity reviewed and corrected (by Jean DAVID 2001)

We suppose that the train is  
300,000 km wide (1 second-light)

The train is moving at high speed  $V$   
For example,  $c/3$  ou 100,000 km/s

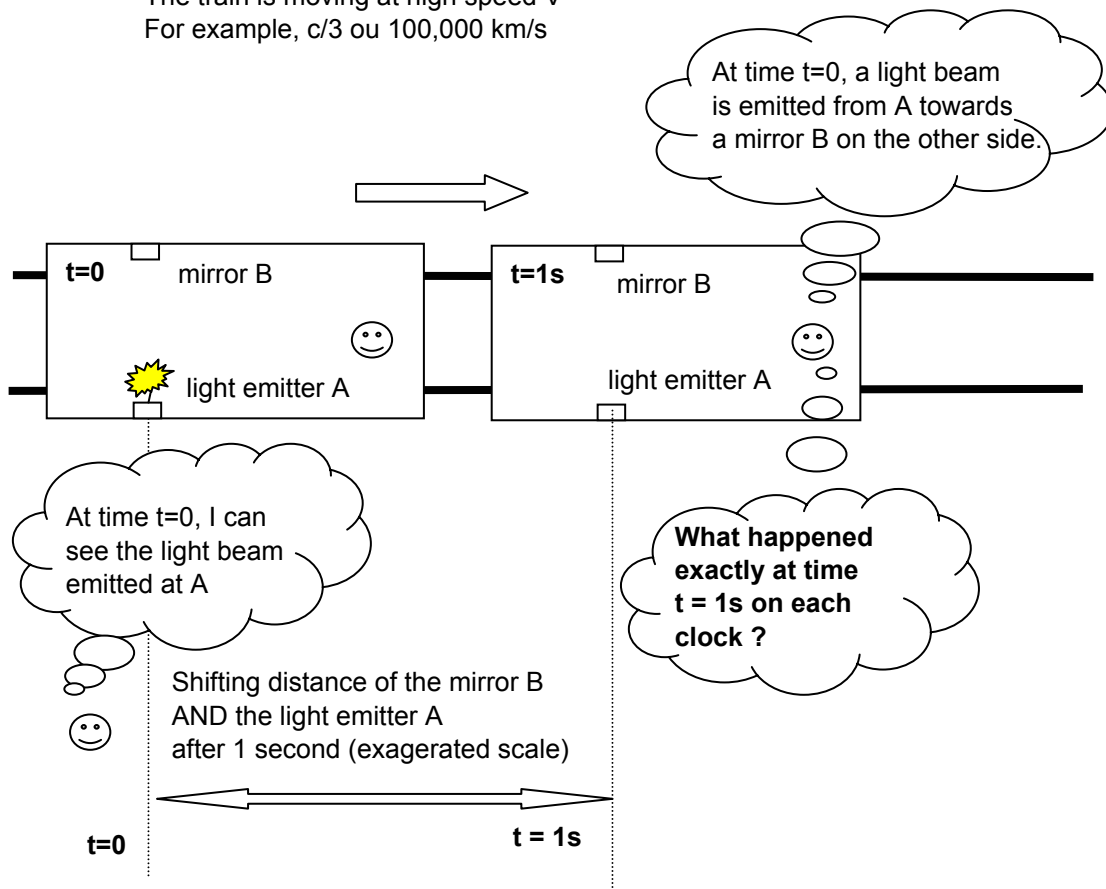



# Relativity reviewed and corrected (by Jean DAVID 2001)

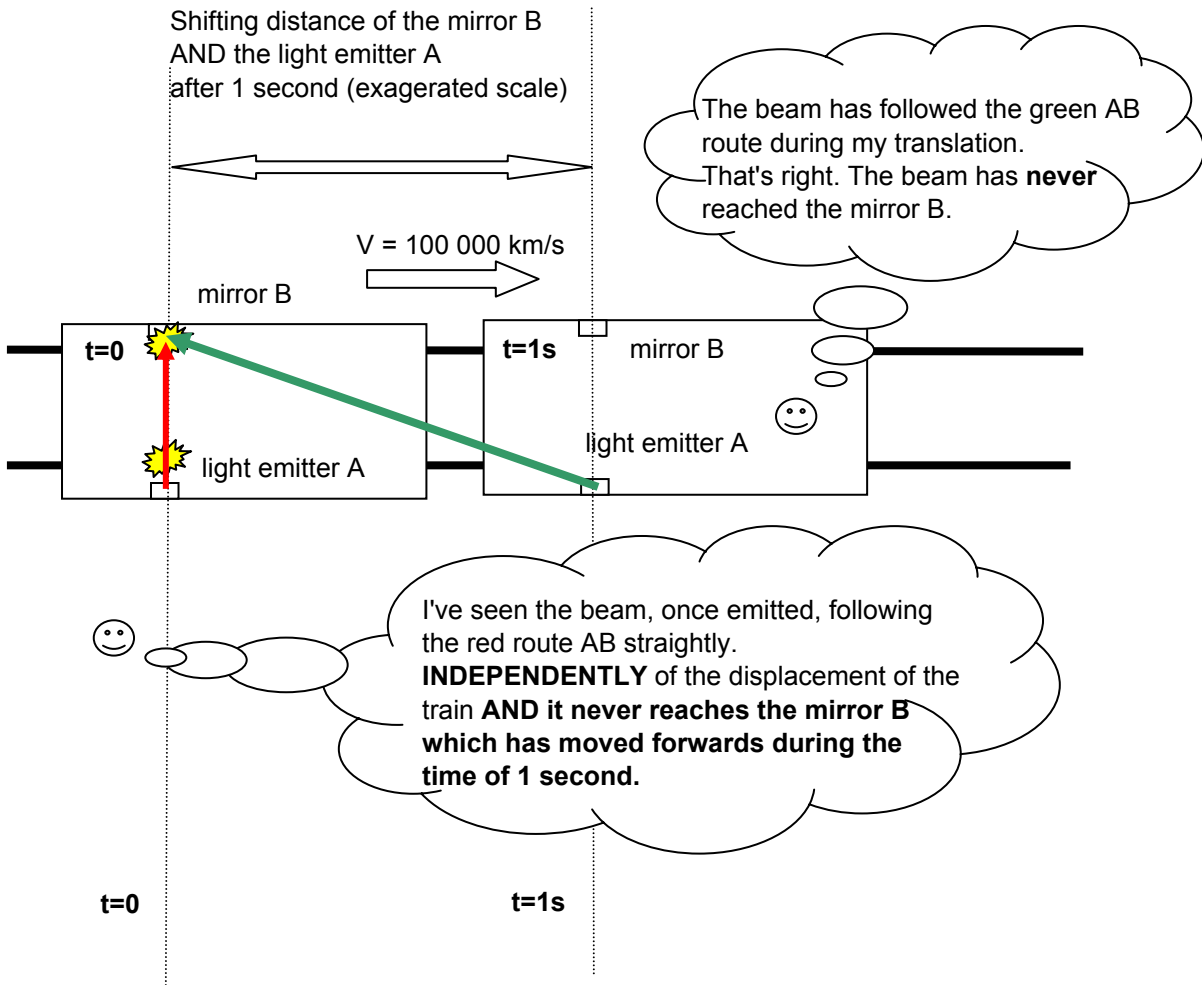

# Relativity reviewed and corrected (by Jean DAVID 2001)

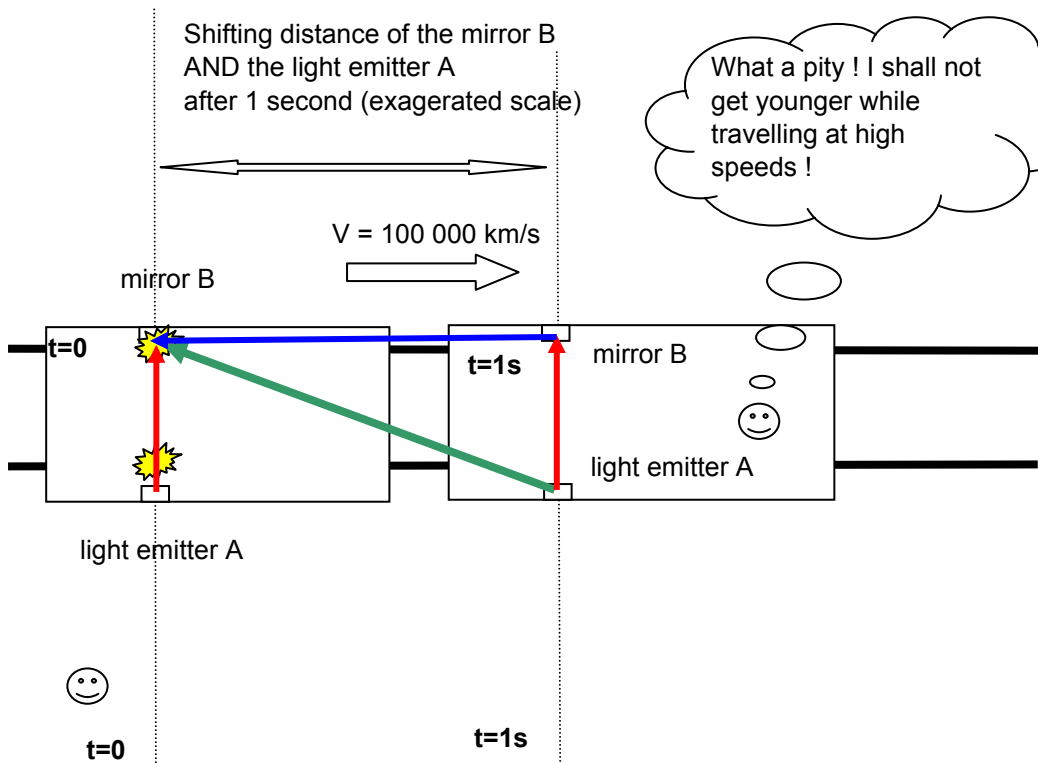

What a pity ! I shall not get younger while travelling at high speeds !

Here, **no more time dilation** as EINSTEIN's belief. The route AB (in green) is simply the combination of the train travelling (in blue) with the beam route (in red). No more paradox ! **Exit LORENTZ's factor !**



# Consequences

What consequences can we get from this new vision of relativity?

1) The speeds can be combined again just as Galileo did without conflicting with the limitation of light speed.

2) Galileo stated, from others experiences more realistic (boat and animals), that there is no absolute movement as itself. The moving of a mobile can only be detected by referencing it to a landmark other than the referential where the observer stands. I agree with him that it was impossible to do that because of the conditions of speed under which the experiences have been realized. The objects were moving too slowly with respect to the light speed and they were not independent physically from the mobile. Even a bird is carried along by the shifting of the boat by the air on which it pushes its wings to fly.

But, by taking in account of what you've just seen, the detection of a proper movement is possible by measuring the deviation angle of the light beam towards the back of the mobile.

I propose in the next pages some examples of how to determine this angle and the conditions we need to observe it.

3) The speed of a mobile makes the light to deviate. Here, no matter, no mass is present, neither any gravitational force. Would the "space curvature" be only an illusion of speed in the case of accelerating systems? I invite you to join me for this new point of view.

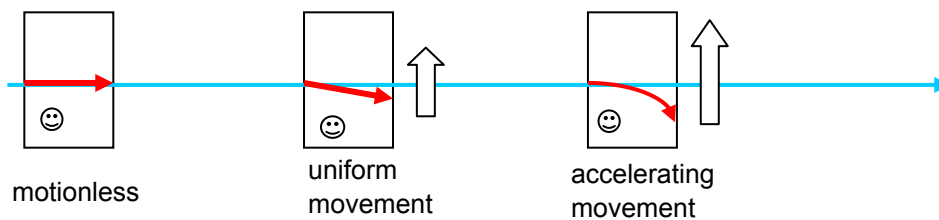

# The deviation that reveals the proper movement

Be the light emitted from inside or outside of a mobile moving at speed  $v$ , the beam will be deviated backwards relative to the direction of the .

The angle  $a$  between the emitted route and the deviated route is :

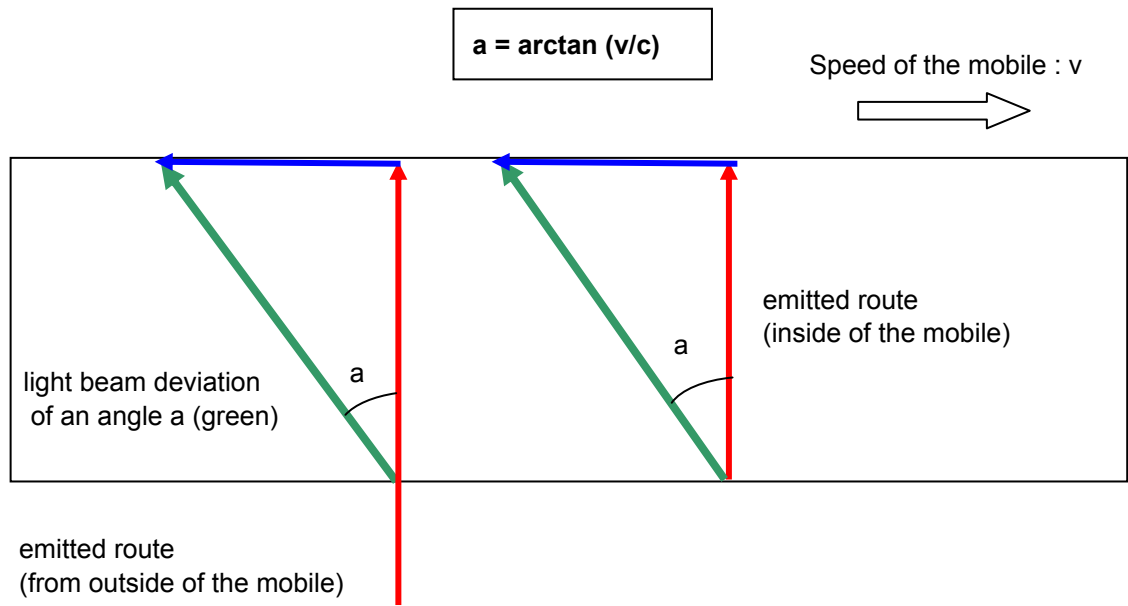

| $v/c$    | km/s   | D            | M  | S  |
|----------|--------|--------------|----|----|
| 1        | 300000 | 45           | 0  | 0  |
| 0,9      | 270000 | 41           | 59 | 13 |
| 0,8      | 240000 | 38           | 39 | 35 |
| 0,7      | 210000 | 34           | 59 | 31 |
| 0,6      | 180000 | 30           | 57 | 49 |
| 0,5      | 150000 | 26           | 33 | 54 |
| 0,4      | 120000 | 21           | 48 | 5  |
| 0,3      | 90000  | 16           | 41 | 57 |
| 0,2      | 60000  | 11           | 18 | 35 |
| 0,1      | 30000  | 5            | 42 | 38 |
| 0,01     | 3000   | 0            | 34 | 22 |
| 0,001    | 300    | 0            | 3  | 26 |
| 0,0001   | 30     | 0            | 0  | 20 |
| 0,00001  | 3      | 0            | 0  | 2  |
| 0,000001 | 0,3    | less than 1" |    |    |
| 1E-07    | 0,03   | less than 1" |    |    |

1) Angle  $a$  computed for different speeds  $v$

2) Speed of a mobile to get a deviation of  $\alpha$

| $\alpha$ | $\alpha$ (rad) | $\tan \alpha = v/c$ | $v$ (km/s) | $v$ (km/h) |
|----------|----------------|---------------------|------------|------------|
| 1''      | 4,85E-06       | 4,85E-06            | 1,454441   | 5235,988   |
| 30''     | 0,000145       | 0,000145            | 43,63323   | 157079,6   |
| 1'       | 0,000291       | 0,000291            | 87,26647   | 314159,3   |
| 30'      | 0,008727       | 0,008727            | 2618,06    | 9425017    |
| 1°       | 0,017453       | 0,017455            | 5236,519   | 18851470   |

To deviate the light beam only by an angle of one second of arc (1''), the speed of the mobile must be at least 5236 km/h.

That is why neither Galileo had been able to detect the movement of a boat just by observing the displacement of objects aboard, nor the physicists of our time with the means of locomotion we have (the french TGV can only go at the record speed of 515,3 km/h that is 10 times less to get a deviation of 1'').

Do you agree with me, Messieurs Galileo and Einstein ?

**Now ! It's your turn to play !**

## **VERY IMPORTANT**

The contents of this document is the intellectual property of Mr Jean DAVID, 9 rue Jean MOULIN à GAGNY (93220) - France.

This document describes in 14 pages the reviewed and corrected Einstein's special relativity. The text and the drawings can not be used without explicit agreements from the author named above.

**To preserve the anteriority of this work, this document has been joined to an email by its author to these following eMail address, the sending and delivering date will be refered for datation :**

**jean.david@sncf.fr  
jeandavid54@aol.com  
jean.david@free.fr**



**All rights reserved  
Copyright 2001 - Jean DAVID**