

IBM Personal System/2

S52G-9971-02

**Hardware
Maintenance
Manual**

October 1994

We Want Your Comments!
(Please see page 440)

IBM Personal System/2

S52G-9971-02

**Hardware
Maintenance
Manual**

October 1994

We Want Your Comments!
(Please see page 440)

IBM

Note

Before using this information and the product it supports, be sure to read the general information under "Notices" on page 445.

Third Edition (October 1994)

The following paragraph does not apply to the United Kingdom or any country where such provisions are inconsistent with local law: INTERNATIONAL BUSINESS MACHINES CORPORATION PROVIDES THIS PUBLICATION "AS IS" WITHOUT WARRANTY OF ANY KIND, EITHER EXPRESS OR IMPLIED, INCLUDING, BUT NOT LIMITED TO, THE IMPLIED WARRANTIES OF MERCHANTABILITY OR FITNESS FOR A PARTICULAR PURPOSE. Some states do not allow disclaimer of express or implied warranties in certain transactions, therefore, this statement may not apply to you.

This publication could include technical inaccuracies or typographical errors. Changes are periodically made to the information herein; these changes will be incorporated in new editions of the publication. IBM may make improvements and/or changes in the product(s) and/or the program(s) described in this publication at any time.

It is possible that this publication may contain reference to, or information about, IBM products (machines and programs), programming, or services that are not announced in your country. Such references or information must not be construed to mean that IBM intends to announce such IBM products, programming, or services in your country.

Requests for technical information about IBM products should be made to your IBM authorized reseller or IBM marketing representative.

Copyright International Business Machines Corporation 1992, 1994. All rights reserved.

Note to U.S. Government users—Documentation related to Restricted rights—Use, duplication, or disclosure is subject to restrictions set forth in GSA ADP Schedule Contract with IBM Corp.

About This Manual

This manual contains service and reference information for IBM® Personal System/2® desktop and floor-standing computers.

The service section includes procedures for isolating problems to a FRU, Symptom-to-FRU Indexes (AT® Bus, Micro Channel®, and QAPlus/PRO**), related service procedures, and an illustrated parts catalog.

The reference section includes safety information, product descriptions, and general information about system functions, and the Advanced Diagnostic tests.

This manual should be used along with the advanced diagnostic tests to troubleshoot problems effectively.

Important

This manual is intended for trained servicers who are familiar with PS/2 products. Before servicing a PS/2 product, be sure to review "Safety Information" on page 365.

* Trademark of the IBM Corporation.

** QAPlus/PRO is a trademark of DiagSoft, Inc.

Related Publications

The following publications are available from IBM or your IBM Authorized Dealer.

For Information About	See Publication
Disk Array technology, RAID Configuration Program	Configuring Your Disk Array booklet (S82G-1506)
Installation Planning for Personal System/2 computers	Personal System/2 Installation Planning and Beyond (G41G-2927)
Installation Planning for Advanced Personal System/2 servers	Advanced PS/2 Servers Planning and Selection Guide (GG24-3927)
PS/ValuePoint* computers	IBM PS/ValuePoint HMM (S61G-1423)
Laptop, Notebook, and Portable computers	IBM Mobile Systems HMM Volume 1 (S82G-1501)
ThinkPad* computers	IBM Mobile Systems HMM Volume 2 (S82G-1502)
Monitors (Displays)	IBM Display HMM - Vol. 1 (SA38-0053) IBM Monitor HMM - Vol. 1 (S68G-2484) IBM Monitor HMM - Vol. 2 (S71G-4197)

Obsolete Publications

This manual obsoletes these previous publications.

Publication	Part, Form Number
PS/2 HMM	71G3716, S52G-9971
PS/2 HMM Supplement	71G6781, S71G-6781
PS/2 HMM Supplement	82G3782, S82G-3782
PS/2 HMM Supplement	82G3836, S82G-3836
PS/2 HMM Supplement	82G3896, S82G-3896
PS/2 OBI Supplement	83G7709, S83G-7709
PS/2 HMM Supplement	83G7836, S83G-7836
PS/2 HMM Supplement	83G7912, S83G-7912
PS/2 OBI Supplement	83G7917, S83G-7917
PS/2 HMM Supplement	83G8084, S83G-8084
PS/2 OBI Supplement	83G8092, S83G-8092
PS/2 OBI Supplement	83G8983, S83G-8983

* Trademark of the IBM Corporation

Contents

Related Publications	iv
Obsolete Publications	iv
Hardware Maintenance Service	1
FRU Replacement Strategy	1
Hard Disk Drive Replacement Strategy	1
Introduction	2
General Checkout (AT Bus)	3
Memory Problems (8086 Computers)	6
Memory Problems (80286 to 80486 Computers)	9
Memory Problems (PC Server - 8640)	10
Installed Devices List	11
Symptom-to-FRU Index (AT Bus)	12
No-Beep Symptoms	12
Beep Symptoms	13
Miscellaneous Symptoms	13
Numeric Error Codes	15
General Checkout (Micro Channel)	19
Devices List	23
Missing Non-SCSI Device	24
Missing SCSI Device	24
Missing SCSI and Non-SCSI Devices	25
System Error Log	25
Viewing the System Error Log	25
Symptom-to-FRU Index (Micro Channel)	26
No-Beep Symptoms	27
Beep Symptoms	29
Audio Symptoms	30
Miscellaneous Symptoms	30
Numeric Error Codes	33
IML and IPL Errors	55
Checking Startup Sequence and Hard Disk Drive	56
General Checkout (QAPLus/PRO)	59
PC Server (8640) Setup Utility	60
Symptom-to-FRU Index (QAPLus/PRO)	61
No Beep Symptoms	62
Beep Symptoms	63
Error Codes	64
Error Messages	66
Miscellaneous Error Messages	72
Network Service Procedures	74
Data Rate Switch Settings	74
Testing the Token-Ring Adapter	74
Token-Ring POST Errors	79
Testing the Ethernet Adapter	81
Ethernet POST Errors	85
Selecting Network Configuration Parameters	87
Network Configuration Errors	89
ISA PS/ValuePoint 10BASE-T/10BASE2 Ethernet Adapters	90

ISA PS/ValuePoint Ethernet Adapter Features	
Diskette	90
ISA PS/ValuePoint Ethernet Adapter Configuration	
Options	90
I/O Address	90
IRQ Interrupt Levels	91
ROM Address	91
Changing PS/ValuePoint ISA Adapter Configuration	91
PS/2 ServerGuard Adapter	92
Cabling	93
External DAA Cabling	93
DAA Cable Check	93
External Power Control Box Cabling	94
ServerGuard Adapter Symptom-to-FRU Index	95
Wireless Network	97
ISA Bus Switch Settings	97
ISA Mode Operations Parameters	97
Wireless LAN Utilities Diskette	99
Placement of Radio Modules	99
Error Management Overview	100
Running Adapter Diagnostics	100
PCMCIA Credit Card Problems	101
Interrupt Level or I/O Address Conflicts	102
Checking the Base Configuration (OS/2 Environment)	102
LAPS Installation Problem	104
Problem Resolution Worksheet	104
Obtaining the Necessary Data	105
Related Service Information	107
ACPA/A Advanced Diagnostic Tests	108
Audio Output Tone (Tone)	108
Microphone Input Loop (Loop)	108
Microphone Gain Toggle (Toggle)	108
CSD (DOS) Version Level Check	108
CSD (OS/2) Version Level Check	108
Combined FRUs Diagnostics	108
Display Adapter 8514/A	109
Display Self-Test	110
Display Considerations	111
Fax/Modem Checkout	112
How to Use a Symptom-to-FRU Index	114
Error Code Format	115
Identifying Adapters	122
Keyboard Voltage Check	123
Standard Connector	123
Memory-Module Kit Identification	123
Memory Problems	125
Models 50, 55, 60, 65, 70, and 80	125
Models 53 (9553-xBx) 56, 57, 76, 77, 85, 90, and 95	125
Determining Models 90/95 Processor Type	126
Processor Board Matrix (90, 95)	126
Using the Low-Level Format Program	129

Option Microprocessor Jumper (76, 77)	130
OS/2 Problems during a New Installation	130
OS/2 Trap Errors	131
PCMCIA Diagnostics (PS/2 E Model 33)	133
PCMCIA Adapter Switch Settings	134
PCMCIA PC Card Lock Override	134
Printer Errors	134
Processor Board Installation (90, 95)	135
Processor Boards with Diagnostic LEDs	135
Processor Boards without Diagnostic LEDs	135
Processor Upgrade (Models 50/50Z/60 - 486SLC2) Switch Settings	136
Processor Upgrade (Models 70/80 - 486DX33) Switch Settings	136
Processor Upgrade (Model 70/80 - 486DX33) FRU Isolation	136
Processor (Px) Label Cross-reference	137
Power Supply Voltage Check	138
Models 25, 25 SX, 25-286	138
Models 30, 30-286	138
Model 33	139
Models 35, 40, 56, 57, 76, 77	140
Models 50, 70	141
Model 55, PS/2 9553-xBx	141
Models 60, 65, 80	142
Model 90	142
PC Server (8640)	143
PC Server 500 (Type 86XX) Power Supplies	145
Server 85, PS/2 9585-xKx, PS/2 9585-xNx, Model 95, and 3511	147
Model 3510	148
Model 3532	148
OBI DASD Hot Swap Storage Expansion Enclosure	149
Real-Time Clock Problems	150
Remote Power-on Jumper (95)	150
Running Automatic Configuration	150
ServerGuide CDs (Type 86XX)	151
SCSI Controller on the System Board	180
SCSI Device Default Settings	180
Enable and Disable Settings	180
Keep/Remove Settings	180
Changing the Settings	180
SCSI Diagnostic Tests	181
SCSI ID (Using to Help Isolate Failures)	181
Servicing LAN Stations (Workstations)	181
Software/Hardware Mismatch Problems	181
Undetermined Problems	183
VPD Codes Information	183
Recording the Vital Product Data on a New System Board	184
System Board Locations	185
Model 25 System Board (Type 1)	185
Model 25 System Board (Type 2)	186

Model 25-286 System Board	187
Model 25 SX System Board	188
Model 30 System Board	189
Model 30-286 System Board	190
Model 33 System Board	191
Model 35, 40 System Board	192
Model 50 System Board (Type 1)	193
Model 50 System Board (Type 2)	193
Models 50, 50Z 486SLC2 System Board Upgrade	194
Model 53 (9553-xBx) System Board	195
Model 55 System Board	196
Model 55 486SLC2 System Board Upgrade	197
Model 56, 57 (8556, 8557) System Board	198
Model 56, 57 (9556, 9557) System Board	199
Model 60 System Board	200
Model 65 System Board	201
Models 60, 65, and 80 486DX2 and 486DLC2 System Board Upgrade	202
Model 70 System Board, Reduced Size (16 MHz, 20 MHz)	203
Model 70 System Board, Full Size (16 MHz, 20 MHz)	203
Model 70 System Board (25 MHz)	204
Model 70 486DX33 and 486DLC2 System Board Upgrade	205
Model 76, 77 (9576, 9577) System Board	206
Model 80 (041, 071, 111, 121, 311, 321) System Board	207
Model 80 (A16, A21, A31) System Board	208
Server 85 (486) System Board	209
PS/2 9585-xKx, and 9585-xNx System Board	210
Model 90 XP 486 System Board	211
Model 95 XP 486 System Board	212
Server 9595, 9595A	213
PC Server 486DX2 System Board	214
PC Server Pentium System Board	218
Parts Catalog	222
Model 25, 25-286, 25SX (8525) Parts	223
Model 30 (8530) Parts	227
Model 30-286 (8530) Parts	229
Model 33 (9533) Parts	231
Model 35 (8535) Parts	233
Model 40 (8540) Parts	236
Model 50 (8550) Parts	239
Model 53 (9553) Parts	241
Model 55 (8555) SX Parts	243
Model 56 (8556) Parts	246
Model 57 (8557) Parts	248
Model 60 (8560), 65 (8565), and 80 (8580) Parts	251
Model 70 (8570) Parts	254
Models 56, 76 (9556, 9576) Parts	257
Models 57, 77, M57, M77 (9557, 9577) Parts	260
Model 90 (8590) Parts	263

PC Server (8640) Parts	267
PC Server 500 (Type 86XX) Parts	270
Server 85 (9585), Model 95 XP 486 (8595) Parts	273
Server 9595, PS/2 9585-xKx, and PS/2 9585-xNx Parts	277
Server 9595A Parts	280
Model 3509 Parts	285
Model 3510 Parts	287
Model 3511 Parts	289
Model 3532 Parts	291
OBI DASD Hot Swap Storage Expansion Enclosure Parts	293
Common Parts	295
486 DX, DX2, DLC2, SLC, SLC2 System Board Upgrade Parts	295
CD-ROM Drives	296
Element Exchange Displays	297
External Diskette Drives	298
Keyboard/Mouse	298
Miscellaneous Parts Kits	300
Power Cords	304
Rewritable Optical Drives	305
ServerGuard Adapter Parts	306
SCSI Adapter Terminators	308
Tools and Miscellaneous	308
Wireless LAN Adapter (ISA, Micro Channel Bus)	309
Wireless LAN Adapter (PCMCIA Type II)	310
Options and Adapters Matrix	311
Hardware Maintenance Reference	363
Safety Information	365
General Safety	365
Electrical Safety	366
Safety Inspection Guide	368
Handling Electrostatic Discharge-Sensitive Devices	369
Grounding Requirements	369
Drive and Diskette Compatibility Matrix	370
Hard Disk Drive Settings (ATA)	371
Preparing a Hard Disk for Moving	374
Security	375
U-Bolt	375
Cover Lock and Tamper-Evident Switches	375
Rear-Panel Security Option	375
Passwords	376
Removing a Power-On Password	376
Additional Override Jumper Functions	378
Unattended Start Mode (Server Mode)	378
Override Jumpers on IML Systems	378
Privileged-Access Password	378
Power-on Features	380
System Features	380
Microprocessors	380
Processor Boards (70)	380

Processor Boards (90, 95)	380
NVRAM and NVRAM Extension	381
POST Overview	381
POST and BIOS in ROM	382
POST and BIOS in IML	382
POST and BIOS in FLASH	382
Errors during POST	383
Reference and Diagnostic Diskettes	383
Accessing System Programs and Starting	
Diagnostic Tests	384
Replacing Hard Disk Drives That Have a	
System Partition	385
QAPLus/PRO Diagnostics	386
Power-On Self-Test (POST)	386
POST Beep Codes	387
Test Programs	387
Error Messages	388
Return Codes	388
Using the Test Programs	389
Program Navigation	389
Using the First Letter of a Menu Choice	389
Using the Function Keys	389
Command Line Options	390
Viewing the Test Groups	390
Scripting	391
Changing Logical Unit Numbers	391
Test Group Specifications	391
Starting the QAPLus/PRO Diagnostics Diskette	391
Module Testing Mode	392
Running Selected Module Tests	392
Running All Selected Modules	392
Changing Selected Tests in Test Groups	392
Running an Individual Test	393
Stopping the Tests	393
Using the System Utilities	393
Formatting Diskettes	393
Using the Low-Level Format Program	394
When To Use the Low-Level Format Program	394
Preparing the Hard Disk Drive for Use	394
File Editor	394
File Edit Function Key Usage	394
QAPLus/PRO Diagnostics Control Keys	396
Disk Array System	396
Storage Capacity	397
Data Protection	397
Hot-Spare Drive	398
Hot-Spare Drive Replacement	398
Bay IDs	398
Configuration	398
Saving Disk Array Configuration to Diskette	399
Restoring the Disk Array Configuration	399
Recording the Vital Product Data on a New	
System Board	400
Upgradable POST and BIOS	400

PCMCIA Adapter (Model 33)	400
Video	401
Non-IBM Displays	402
Serial Port	403
Parallel Port	404
Supported Cables	404
Diskette-Drive Controller	404
Keyboard and Pointing-Device Connectors	404
System Memory	405
System-Board Memory	405
Memory-Expansion Adapters	405
Memory Errors	405
Unique Memory Information (90, 95)	406
Model 90 Memory	406
Model 95 Memory	406
Memory Configurations (90, 95)	407
Error Detection (90, 95)	407
Resolving Memory-Address Conflicts	408
Changing the Software Configuration	408
Changing the System Configuration	408
SCSI System Information	409
SCSI Hard Disk Drives and Devices	409
Understanding SCSI ID Numbers	409
Selecting a SCSI ID	409
Setting a SCSI ID	411
SCSI ID Switch Settings	411
SCSI ID Jumper Settings	412
2GB SCSI 16-Bit 68-Pin Hard Disk Drive ID Switch Settings	412
Optical-Head Lens Cleaning Procedure	413
Setting the Motor-Start Jumper	414
Terminator Function	414
16-Bit AT Fast SCSI Adapter Switch Settings	415
Interrupt Settings	415
Memory Address Switch Settings	415
I/O Address	416
Internal Devices Attached to an Adapter	417
External Devices Attached to an Adapter	417
Terminators on SCSI Adapters	418
Terminators on System Boards	419
Selectable Drive-Startup Function	420
To Change the Startup Sequence	421
System-Unit Power Supplies	422
Power-Supply Features	422
Operating Voltage Range	422
No-Load Operation	422
Over-Current Protection	422
Short-Circuit Protection	422
Over-Voltage Protection	422
Under-Voltage Protection	422
Automatic Restart	422
Power-Line Disturbances	423
Surge Protection	424
Safety	424

Current Leakage	424
Reliability	424
Uninterruptible Power Devices	424
System Partition	425
Starting System Program Diagnostics	425
Updating the System Programs	426
Upgrading the System Partition Version	426
Backing up the System Partition	427
Restoring the System Partition	428
Running Automatic Configuration	429
Recording a Customized Configuration	429
ASCII Terminals	430
ASCII Terminal Setup and Menu Selection	430
ASCII Terminal Configuration	431
Console Selection	431
Operation	432
Error Messages	432
96 8N1 Error Message	432
System Error Log	433
Viewing the Error Log	433
Types of Errors Detected	433
Application Program Errors	433
Processor Errors	433
System Memory Errors	433
Micro Channel Adapter Errors	433
Error Storage	434
Application	434
Dumping Extended Diagnostic Data Information	434
PS/2 System Specifications	435
PS/2 - AT Bus	435
PS/2 - Micro Channel (Non IML)	436
PS/2 - Micro Channel (IML)	437
Acronyms, Abbreviations, and Terms	438
We Want Your Comments!	440
Do You Need Technical References?	441
Problem Determination Tips	442
Phone Numbers, U.S. and Canada	443
Notices	445
Trademarks	445
Index	447

Hardware Maintenance Service

This part of the manual contains the general checkout procedures, related service procedures, Symptom-to-FRU indexes, and parts listings for PS/2 products.

Note: This manual and the diagnostic tests are intended to test **only** IBM products. Non-IBM products of any kind including adapter cards, accelerator boards, options, or non-IBM devices, can give false errors and invalid computer responses. If you remove a non-IBM device and the symptom goes away, the problem is with the device you removed.

Warning: The drives in the computer you are servicing might have been rearranged or the drive startup sequence changed. Be extremely careful during write operations such as copying, saving, or formatting. Data or programs can be overwritten if you select an incorrect drive.

FRU Replacement Strategy

Use the following strategy to prevent unnecessary FRU replacement and service expense:

If you are instructed to replace a FRU and that does not correct the problem, reinstall the original FRU before you continue.

Some computer have both a processor board and a system board. If you are instructed to replace either the processor board or the system board, and the first board that you replaced does not correct the problem, reinstall the original board, then replace the other (processor or system) board.

Note: Pressing down on the blue levers on the Model 90/95 processor board does not fully seat the processor board into the system board connector. To ensure that the processor board is fully seated, press down firmly on the middle of the board until it is fully seated.

If an adapter or device consists of more than one FRU, an error code may be caused by any of the FRUs. Before replacing the adapter or device, remove the FRUs, one by one, to see if the symptoms change. Replace only the FRU that changed the symptoms.

Hard Disk Drive Replacement Strategy

Always try to run a low-level format before replacing a hard disk drive (see "Using the Low-Level Format Program" on page 129).

Introduction

Before using the General Checkout procedures and Symptom-to-FRU Indexes, read the following information.

The two types of PS/2 computers are:

- At Bus
- Micro Channel

Note

See "PS/2 System Specifications" on page 435 for a description of IBM PS/2 Computers and their features.

Depending on the PS/2 model computer you are servicing, you need to be familiar with the following diagnostic procedures.

The three types of diagnostics are:

- AT Bus Diagnostics
- Micro Channel Diagnostics
- QAPlus/PRO Diagnostics

The General Checkout procedures are:

- "General Checkout (AT Bus)" on page 3
- "General Checkout (Micro Channel)" on page 19
- "General Checkout (QAPlus/PRO)" on page 59

The Symptom-to-FRU Indexes are:

- "Symptom-to-FRU Index (AT Bus)" on page 12
- "Symptom-to-FRU Index (Micro Channel)" on page 26
- "Symptom-to-FRU Index (QAPlus/PRO)" on page 61

Important

Before running diagnostics, run a virus checking program. If the computer you are servicing has been infected with a PC virus, a virus checking program can find the virus before it causes more damage.

General Checkout (AT Bus)

This general checkout procedure supports the following PS/2 Models:

25, 25 SX, 25-286, 30, 30-286, 33, 35, 40, and 55.

Before using this checkout procedure, be sure to read the information under "Introduction" on page 2.

001

1. Power-off the computer and all external devices.
2. Check all cables and power cords.
3. Make sure there are no diskettes in the drives.
4. Power-on all external devices.
5. Power-on the computer.

DID YOU RECEIVE A POST ERROR CODE?

Yes No

002

Go to Step 014 on page 4.

003

IS THE ERROR 162?

Yes No

004

Go to Step 014 on page 4.

005

IS THE DIAGNOSTIC PROGRAM LOADED FROM THE LAN?

Yes No

006

Insert the Advanced Diagnostics Diskette. Go to Step 009.

007

– Load the diagnostic program from the server.

DID THE PROGRAM LOAD SUCCESSFULLY?

Yes No

008

If the problem occurred during the Remote Initial Program Load (RIPL), replace the Network Adapter. If it did not occur during RIPL, go to "Symptom-to-FRU Index (AT Bus)" on page 12.

009

(Step 009 continues)

(CONTINUED)

009 (continued)

– Press **Ctrl+Alt+Del** and check for the following responses:

1. One or two short beeps.
2. IBM logo screen appears.

DID YOU RECEIVE THE RESPONSES LISTED ABOVE?

Yes No

010

Go to “Symptom-to-FRU Index (AT Bus)” on page 12. If that does not correct the problem, go to “Undetermined Problems” on page 183.

011

– Press **Enter**.

HAS THE CONFIGURATION BEEN INTENTIONALLY CHANGED?

Yes No

012

Type **N**, then go to Step 020 on page 5.

013

Type **Y** to run Automatic Configuration and verify the error is no longer present. If you return to this point again, go to Step 011 and type **N**.

014

IS THE DIAGNOSTIC PROGRAM LOADED FROM THE LAN?

Yes No

015

Insert the Advanced Diagnostics Diskette. Go to Step 018 on page 5.

016

– Load the diagnostic program from the server.

DID THE PROGRAM LOAD SUCCESSFULLY?

Yes No

017

If the problem occurred during the Remote Initial Program Load (RIPL), replace the Network Adapter. If it did not occur during RIPL, go to “Symptom-to-FRU Index (AT Bus)” on page 12.

018

(Step **018** continues)

018 (continued)

– Press **Ctrl+Alt+Del** and check for the following responses:

1. One or two short beeps.
2. IBM logo screen appears.

DID YOU RECEIVE THE RESPONSES LISTED ABOVE?

Yes No

019

Go to “Symptom-to-FRU Index (AT Bus)” on page 12. If that does not correct the problem, go to “Undetermined Problems” on page 183.

020

- Press **Enter**.
- Select test system.
- Select system checkout.

Go to “Related Service Information” on page 107 for:

Incorrect keyboard responses
Incorrect printer responses
Incorrect display responses (jittering, rolling, shifting, or out of focus)

IS THE LIST OF INSTALLED DEVICES CORRECT?

Yes No

021

Go to “Installed Devices List” on page 11.

022

- Run the advanced diagnostic tests.

DID THE TESTS IDENTIFY A FAILURE?

Note: If the test stops and you cannot continue, replace the last device being tested.

Yes No

023

You may have an intermittent problem:

Check for damaged cables and connectors.
Reseat all adapters, drives, and modules.
Check the system unit fan for proper operation.
Start an error log using a DOS formatted diskette and run the tests multiple times.

024

Follow the instructions on the display.

If that does not correct the problem, go to “Symptom-to-FRU Index (AT Bus)” on page 12.

Memory Problems (8086 Computers)

Go to "Memory Problems (80286 to 80486 Computers)" on page 9 for models: 25, 25 SX, 25 286, 30, 30 286, 33, 35, and 40.

PARITY CHECK 1 indicates that memory on the system board has failed. If the system has a total of 512KB memory installed (8525), replace the memory module packages. If the system has a total of 640KB memory installed and the address (number displayed below PARITY CHECK 1) is less than 20000, replace the optional memory modules (8525), or the system board (8530). Otherwise, replace the memory module (8525) or S1 and S2 (8530).

PARITY CHECK 2 indicates that an adapter memory module has failed. Go to "Undetermined Problems" on page 183.

001

Memory errors are displayed as:

AAAAAA BB CCCC 20X

To isolate a memory failure, answer the following questions.

DID YOU RECEIVE A "205 MEMORY ERROR" MESSAGE DURING POST OR WHEN RUNNING THE MEMORY TESTS?

Yes No

Yes **002**
Go to Step 011.

003

IS THE SYSTEM A TYPE 8530?

Yes No

Yes **004**
Go to Step 006.

005

Replace the system board.

006

IS CCCC FOUR ZEROS (0000)?

Yes No

007

For any C in CCCC that is not zero, replace the corresponding module as shown:

C C C C
U35 U34 U22 U16

008

WAS THE SIXTH DIGIT IN AAAAAA 1, 3, 5, 7, 9, B, D, or F?

Yes No

009

Replace memory module ZM1.

010

Replace memory module ZM2.

011

IS BB AN 01?

Yes No

012

IS CCCC FOUR ZEROS?

Yes No

013

ARE THE LAST TWO Cs IN CCCC ZEROS (00)?

Yes No

014

Replace Memory Module Package 1 (8525) or S2 (8530).

015

Replace Memory Module Package 2 (8525) or S1 (8530).

016

(Step **016** continues)

(CONTINUED)

016 (continued)

**WAS THE SIXTH DIGIT IN AAAAAA 1, 3, 5, 7, 9,
B, C, D, OR F?**

Yes No

017

Replace Memory Module Package 1 (8525) or
S2 (8530).

018

Replace Memory Module Package 2 (8525) or S1
(8530).

019

The adapter memory failed. Go to "Undetermined
Problems" on page 183.

Memory Problems (80286 to 80486 Computers)

001

1. Power-off the computer and wait 5 seconds.
If your model has a diskette drive, insert the Advanced Diagnostics Diskette into the diskette drive.
If not, contact the LAN administrator to load the diagnostic program from the LAN.
2. Power-on the computer.
3. Make a note of any POST errors you receive.
(Disregard the 164 memory size errors.)

DID YOU RECEIVE A XXXXXX XXXX 201 POST ERROR?

Yes No

002

Press **F1** to continue.

- Run the memory tests. Use the RUN TESTS ONE TIME option.

DID THE MEMORY TESTS COMPLETE WITHOUT AN ERROR?

Yes No

003

Follow the instructions on the display.

004

Your computer memory is now functioning correctly.
If you suspect an intermittent problem, start an error log using a DOS formatted diskette.

005

Note: Power-off the computer before removing or replacing parts.

Press **F1** to continue.

- Run the memory tests. Use the RUN TESTS ONE TIME option. If you cannot run the memory test or the test does not find a problem, use the following procedure to find the problem.
 1. Using a known good memory pack, exchange each pack, one at a time, and repeat the memory diagnostic test until you find the defective pack (256KB and 1MB packs are not interchangeable). Replace *only* the defective packs.
 2. If all memory packs have been exchanged, and the problem remains, replace the system board.

Memory Problems (PC Server - 8640)

The PC Server (8640) has four, 36-bit (72-pin) SIMM sockets on the system board. The system board can accommodate memory from 8MB up to 128MB (192MB on some models).

The following are the memory requirements for the PC Server computer:

- At least two SIMM sockets must be filled. Start with bank 0, then work your way up.

- The SIMMs must be rated at 70NS or better.

- Recommended that the SIMMs have tin-lead contacts.

- Banks 0 and 1 must have the same size memory installed.

- If memory is installed in banks 2 and 3, the memory in banks 2 and 3 must be the same size.

Installed Devices List

If an adapter or device is missing from the Installed Devices list and you are able to add it to the list, do so and continue with the diagnostic tests.

If an adapter or device is missing from the installed devices list and you cannot add it to the list, you might have one of the following conditions:

- The diagnostic code for the missing device is not on your Advanced Diagnostics diskette.
- The missing device is a 5.25-Inch External Diskette Drive Adapter, or another unrecognizable adapter.
- The missing device is defective.
- The bus adapter is defective.
- The adapter or device is not an IBM product.

If the number of drives installed in the computer differs from the number shown in the installed devices list, an error can occur during the diagnostic tests. Restart the computer and correct the drive information in the Set Configuration menu before running the diagnostic tests.

Warning

For some models, a customized setup configuration (other than default settings) might exist on the computer you are servicing. Running Automatic Configuration can alter those settings. Note the current configuration settings (using the View Configuration option) and verify that the settings are in place when service is complete.

Symptom-to-FRU Index (AT Bus)

This index supports the following PS/2 Models:

25, 25 SX, 25-286, 30, 30-286, 33, 35, 40, 55.

Always start with "General Checkout (AT Bus)" on page 3.

For information on:	Go to:
Additional Service help. (For example, voltage checks, or OS/2 Trap errors)	"Related Service Information" on page 107.
Possible software and hardware mismatch problems (not repairable by replacing FRUs).	"Software/Hardware Mismatch Problems" on page 181.
Starting the System Programs	"Starting System Program Diagnostics" on page 425.
Erasing Power-On Passwords	"Removing a Power-On Password" on page 376.
Memory Address Conflicts	"Resolving Memory-Address Conflicts" on page 408.

No-Beep Symptoms

Symptom/Error	FRU/Action
No beep, power-on indicator does not come on, and fan does not run. (Check voltage selector switch setting)	1. Power Supply
No beep during POST (Check voltage selector switch setting)	1. System Board 2. Power Supply 3. Display Assembly (8525) 4. Memory Module (8525) 5. Any Adapter 6. Bus Adapter
No beep, fan runs, power-on indicator is on, and computer hangs during POST with a message displayed.	1. System Board 2. Power Supply
No beep and the computer is otherwise functional.	1. Speaker Assembly

Beep Symptoms

Symptom/Error	FRU/Action
One long and two short beeps during POST	<ol style="list-style-type: none"> System Board Display Adapter
More than one beep during POST	<ol style="list-style-type: none"> System Board Any Adapter
Continuous beep	<ol style="list-style-type: none"> System Board
Repeated short beeps	<ol style="list-style-type: none"> Keyboard (stuck key?) Keyboard Cable System Board
†	If this symbol is shown next to an error (above), go to "Related Service Information" on page 107.
‡	If this symbol is shown next to an error (above), go to "Memory Problems (8086 Computers)" on page 6.

Miscellaneous Symptoms

Symptom/Error	FRU/Action
Blank or unreadable display (Check display) †	<ol style="list-style-type: none"> System Board Power Supply Display Adapter Display Assembly System Board Video Cable
Other display problems (Check display) †	<ol style="list-style-type: none"> System Board Display Adapter Display System Board Video Cable
Insert Diskette Icon appears, or system enters BASIC	<ol style="list-style-type: none"> Diskette Drive System Board Diskette Cable Network Adapter
Bad Diskette Icon	<ol style="list-style-type: none"> Diskette Diskette Drive System Board Diskette Cable
Incorrect memory size during POST, or Parity Check 1 (Check memory) ‡	<ol style="list-style-type: none"> System Board
Parity Check 2 (Check memory) ‡	<ol style="list-style-type: none"> Adapter Memory Memory Adapter Bus Adapter System Board
†	If this symbol is shown next to an error (above), go to "Related Service Information" on page 107.
‡	If this symbol is shown next to an error (above), go to "Memory Problems (8086 Computers)" on page 6.

Symptom/Error	FRU/Action
Serial or Parallel port device failure	<ol style="list-style-type: none"> 1. Device (self test OK?) 2. System Board 3. Bus Adapter
XXXX ROM Error	<ol style="list-style-type: none"> 1. Any Adapter
Some or all of the keys on the keyboard do not work.	<ol style="list-style-type: none"> 1. Keyboard 2. System Board 3. Keyboard Cable
Real Time Clock loses time. (This is not always a hardware failure. See "Real-Time Clock Problems" on page 150)	<ol style="list-style-type: none"> 1. Bus Adapter 2. Clock Module 3. System Board
†	If this symbol is shown next to an error (above), go to "Related Service Information" on page 107.
‡	If this symbol is shown next to an error (above), go to "Memory Problems (8086 Computers)" on page 6.

Numeric Error Codes

Symptom/Error	FRU/Action
131XX (Cassette wrap failure)	(Information only)
161, 163, 165	<ol style="list-style-type: none"> Set Time and Date Bus Adapter Clock Module Battery System Board
162	<ol style="list-style-type: none"> Run Setup Run Automatic Configuration Clock Module System Board
162 (and unable to run advanced diagnostics)	<ol style="list-style-type: none"> Diskette Drive System Board Diskette Drive Cable
164 (Check memory) †	<ol style="list-style-type: none"> Run Setup Run Automatic Configuration System Board
199	<ol style="list-style-type: none"> Any Device
1XX	<ol style="list-style-type: none"> System Board
2XX (Check memory) †	<ol style="list-style-type: none"> System Board
302	<ol style="list-style-type: none"> Is the Keylock Locked? Keylock Assembly System Board
3XX (not listed above)	<ol style="list-style-type: none"> Keyboard System Board Keyboard Cable
5XX	<ol style="list-style-type: none"> System Board Display Adapter
602	<ol style="list-style-type: none"> System Board Diskette Drive Diskette Drive Cable
604, 662	<ol style="list-style-type: none"> Wrong Diskette Drive Type
663	<ol style="list-style-type: none"> Wrong Media Type
6XX (not listed above)	<ol style="list-style-type: none"> Diskette Drive External Drive Adapter System Board Power Supply Display Assembly (8525) Diskette Drive Cable
†	If this symbol is shown next to an error (above), go to "Related Service Information" on page 107.
‡	If this symbol is shown next to an error (above), go to "Memory Problems (8086 Computers)" on page 6.

Symptom/Error	FRU/Action
7XX	<ol style="list-style-type: none"> 1. Math Coprocessor 2. System Board
9XX †	<ol style="list-style-type: none"> 1. Printer 2. System Board
1002	<ol style="list-style-type: none"> 1. Alternate Parallel Adapter-Jumpers 2. Alternate Parallel Adapter
1047	<ol style="list-style-type: none"> 1. 16 Bit AT SCSI Fast Adapter
10XX (not listed above)	<ol style="list-style-type: none"> 1. Alternate Parallel Adapter 2. Bus Adapter
11XX	<ol style="list-style-type: none"> 1. System Board
1202	<ol style="list-style-type: none"> 1. Alternate Serial Adapter-Jumpers 2. Alternate Serial Adapter 3. Bus Adapter
12XX	<ol style="list-style-type: none"> 1. Alternate Serial Adapter 2. Bus Adapter
13XX	<ol style="list-style-type: none"> 1. Game Control Adapter 2. Bus Adapter
14XX †	<ol style="list-style-type: none"> 1. Printer
15XX	<ol style="list-style-type: none"> 1. SDLC Adapter 2. Bus Adapter
16XXXX	<ol style="list-style-type: none"> 1. 36/38 Workstation Adapter
17XX (Model 9533 systems may produce false 1702 and 1713 error. If no other symptoms are detected, ignore these errors.)	<ol style="list-style-type: none"> 1. Hard Disk Drive 2. System Board 3. Hard Disk Cable 4. Power Supply 5. Display Assembly (8525)
209X	<ol style="list-style-type: none"> 1. Diskette Drive 2. Diskette Drive Cable 3. 16 Bit AT SCSI Fast Adapter
20XX (not listed above)	<ol style="list-style-type: none"> 1. BSC Adapter 2. Bus Adapter
21XX	<ol style="list-style-type: none"> 1. SCSI Device 2. 16 Bit AT SCSI Fast Adapter 3. Alternate BSC Adapter 4. Bus Adapter
†	If this symbol is shown next to an error (above), go to "Related Service Information" on page 107.
‡	If this symbol is shown next to an error (above), go to "Memory Problems (8086 Computers)" on page 6.

Symptom/Error	FRU/Action
2401, 2402 (If screen colors change)	1. Display
2401, 2402 (If screen colors are OK)	1. System Board 2. Display
2409	1. Display
2410	1. System Board 2. Display
28XX	1. 3278/79 Adapter 2. Coaxial Cable 3. Bus Adapter
3015, 3040	1. Network Attached? 2. LF Translator 3. Cable Problem 4. PC Network Adapter 5. Bus Adapter
30XX	1. PC Network Adapter 2. LF Translator 3. Cable Problem 4. Bus Adapter
3115, 3140	1. Network Attached? 2. LF Translator 3. Alternate PC Network-Adapter 4. Cable Problem 5. Bus Adapter
31XX	1. Alternate PC Network-Adapter 2. LF Translator 3. Cable Problem 4. Bus Adapter
36XX	1. GPIB Adapter 2. Bus Adapter
38XX	1. DAC Adapter 2. Bus Adapter
64XX (See "Network Service Procedures" on page 74)	1. Ethernet Adapter
74XX	1. Display Adapter 2. Bus Adapter
80XX	1. PCMCIA Adapter
84XX	1. Speech Adapter 2. Speech Control Assembly 3. Bus Adapter
85XX	1. 2MB Exp. Memory Adapter 2. Bus Adapter
†	If this symbol is shown next to an error (above), go to "Related Service Information" on page 107.
‡	If this symbol is shown next to an error (above), go to "Memory Problems (8086 Computers)" on page 6.

Symptom/Error	FRU/Action
86XX	<ol style="list-style-type: none"> 1. Mouse 2. System Board
89XX	<ol style="list-style-type: none"> 1. PC Music Adapter 2. MIDI Adapter Unit 3. Bus Adapter
106X1	<ol style="list-style-type: none"> 1. Set Configuration 2. Ethernet Adapter
10635	<ol style="list-style-type: none"> 1. Power-off the computer, wait six seconds; then power-on the computer. 2. Ethernet Adapter
10651, 10660	<ol style="list-style-type: none"> 1. Check Cables 2. Ethernet Adapter
106XX (not listed above) (see "Network Service Procedures" on page 74)	<ol style="list-style-type: none"> 1. Ethernet Adapter
129XX	<ol style="list-style-type: none"> 1. Processor Board 2. Cache Kit 3. System Board
166XX, 167XX (See "Network Service Procedures" on page 74)	<ol style="list-style-type: none"> 1. Token Ring Adapter 2. System Board 3. Bus Adapter (if used)
243XX	<ol style="list-style-type: none"> 1. System Board
027801XX to 027879XX	<ol style="list-style-type: none"> 1. Personal Dictation System Adapter 2. System Board
027880XX to 027889XX	<ol style="list-style-type: none"> 1. External FRU (Speaker, Microphone)
‡999XXXX (There is an optional SCSI adapter installed)	<ol style="list-style-type: none"> 1. Default Hard Disk 2. SCSI Adapter 3. SCSI Cable
†	If this symbol is shown next to an error (above), go to "Related Service Information" on page 107.
‡	If this symbol is shown next to an error (above), go to "Memory Problems (8086 Computers)" on page 6.

General Checkout (Micro Channel)

This general checkout procedure supports the following PS/2 Models:

50, 55, 56, 57, M57, 60, 65, 70, 76, 77, M77, 80, 85, 90, and 95.

Before using this General Checkout procedure, be sure to read the information under "Introduction" on page 2.

001

- Power-off the computer and all external devices.
- Check all cables and power cords.
- Make sure there are no diskettes in the drives.
- Set all display controls to the middle position.
- Power-on all external devices.
- Power-on the computer.

Notes:

1. On some computers, two tamper-evident switches are installed on the adapter guide located at the lower-left front of the system unit frame. Both switches must be in the "up" or "on" position to supply power to the system. (Move the blue slider up until it contacts the metal actuator arms of the two switches. The switches "click" when activated.) If the switches fail to activate, they must be adjusted or replaced. To adjust the switches, remove the adapter guide with the switches from the system unit. Form the actuator arms so the switches activate when the slider is moved up half the distance of its travel.
 2. If you get a POST error code, press the pause key (while the error code is on the screen). Write down any error codes that are displayed, then press F1 to continue.
 3. If the computer hangs with a POST error, go to "Symptom-to-FRU Index (Micro Channel)" on page 26.
 4. On some Model 95 computers, the customer has the ability to suppress the Press **F1** for **Setup and Diagnostics** prompt. If the prompt **does not** appear, continue with this MAP.
- Check for the following responses:
 1. One or two short beeps.
 2. Readable instructions or the Main Menu.

DID YOU RECEIVE THE CORRECT RESPONSES?

Yes No

002

(Step 002 continues)

(CONTINUED)

002 (continued)

Find the failure symptom in the "Symptom-to-FRU Index (Micro Channel)" on page 26.

003

ARE ANY EXTERNAL SCSI DEVICES ATTACHED TO THE SYSTEM?

Yes No

004

Go to Step 007.

005

DID THE POWER-ON GOOD INDICATOR FOR ALL OF THE EXTERNAL SCSI DEVICES COME ON?

Yes No

006

Check the voltages. Go to "Related Service Information" on page 107.

007

DID YOU RECEIVE A POST ERROR CODE?

Yes No

008

Note: You might have an intermittent failure. Go to "System Error Log" on page 25 to see if any errors are logged. If no errors are logged, or if the error log is not supported, go to Step 022 on page 22.

009

IS THE FIRST POST ERROR CODE 0106XXXX, 0166XXXX, OR 0167XXXX?

Yes No

010

Go to Step 012 on page 21.

011

There is a network communication problem. Go to "Symptom-to-FRU Index (Micro Channel)" on page 26 and find the error code. If you suspect another type of network problem, or you just want to test the network adapter, go to "Network Service Procedures" on page 74.

012

(Step **012** continues)

012 (continued)

DOES THE SYSTEM HAVE A SCSI ADAPTER OR DEVICE INSTALLED OR CONNECTED EXTERNALLY?

Yes No

013

Go to Step 022 on page 22.

014

Go to Step 015.

015

IS THE FIRST POST ERROR CODE WITHIN THE RANGE OF 02080000 190I TO 02470000 190I?

Important: If your error code is not in the range or is not followed by a 190I, answer *No*.

Yes No

016

Go to Step 022 on page 22.

017

– Start the system programs.

Note: For instructions on starting the system programs, see “Starting System Program Diagnostics” on page 425.

– Verify the “Enable/Disable” settings are correct. (If you are not familiar with these settings, see “SCSI Device Default Settings” on page 180.)

Note: If you receive a warning on the screen regarding the “Keep/ Remove” settings, follow the instructions on the screen before continuing.

DID YOU HAVE TO CORRECT ANY OF THE ENABLE/DISABLE SETTINGS?

Yes No

018

Go to “Symptom-to-FRU Index (Micro Channel)” on page 26. Before replacing any SCSI devices, verify there are no duplicate SCSI ID settings on the same bus.

019

– Restart the computer (power-off, then on).
(Step 019 continues)

(CONTINUED)

019 (continued)

DID THE POST ERROR REMAIN?

Yes No

020

If you suspect another problem, or you want to run System Checkout, go to Step 022.

021

Go to "Symptom-to-FRU Index (Micro Channel)" on page 26.

022

– Start the system programs.

Note: For instructions on starting the system programs, see "Starting System Program Diagnostics" on page 425.

– If you are not at the Main Menu, follow the instructions on the screen to advance to the Main Menu, then press **Ctrl+A** and run system checkout.

Go to "Related Service Information" on page 107 for:

Undetermined Problems (computer hangs)
Incorrect keyboard responses
Incorrect printer responses
Incorrect display responses (jittering, rolling, shifting, changing colors, or out of focus)

Note: If a minimum of 896KB of memory is not active, the diagnostic tests cannot be loaded.

IS THE DEVICES LIST CORRECT?

Yes No

023

Go to "Devices List" on page 23. If that does not correct the problem, go to "Undetermined Problems" on page 183.

024

– Run the advanced diagnostic tests.

DID THE TESTS IDENTIFY A FAILURE?

Note: If the tests start but do not complete and you cannot continue, replace the device that was being tested.

Yes No

025

Note: If you noticed an error symptom or if you received any POST error codes when the computer was powered-on, go to

“Symptom-to-FRU Index (Micro Channel)” on page 26.

You might have an intermittent problem:

- Check for damaged cables or connectors.
- Reseat all adapters, drives, and modules.
- Check the system fan.
- Go to “Power Supply Voltage Check” on page 138 to check voltages.
- Start an error log and run the tests multiple times.
- If you did not find a problem, go to “Undetermined Problems” on page 183.

026

Follow the instructions on the screen. If that does not correct the problem, go to “Symptom-to-FRU Index (Micro Channel)” on page 26.

Devices List

At the start of the diagnostic tests, the Devices List is displayed. Normally, all adapters and devices installed in the computer appear on the list.

If an adapter or device that appears on the list *is not* installed in the computer, use the procedure in “Undetermined Problems” on page 183 to find the problem.

If an adapter or device that *is* installed in the computer does not appear on the list, you have one of the following conditions:

- The diagnostic (DGS) files for the missing device are not loaded onto the System Partition (run **Copy an option diskette** using the option diskette).
- The SCSI controller failed (on the system board or SCSI adapter).
- An unrecognizable adapter is installed.
- The missing device is defective or it requires an additional diagnostic diskette or service manual.
- A defective adapter caused the device to disappear from the list.

If you are sure that the DGS files are loaded and all the options are supported, note which type of device (SCSI or non-SCSI) is missing from the Devices List, then continue.

Missing Non-SCSI Device

If a non-SCSI device is missing from the list, replace it.

If more than one non-SCSI device is missing, isolate them one at a time until you find the device causing the failure.

Note: If the number of diskette drives shown on the list is incorrect, an error can occur during the tests. If this is the case, restart the computer, select **View Configuration** from the Set Configuration menu and verify that the drive information is correct, then continue testing.

Missing SCSI Device

Note: On some models with SCSI on the system board, slot number 0 or 1 designates the logical position for the SCSI controller. Diagnostics might instruct you to replace the SCSI adapter in slot 0, or 1, leading you to believe that a SCSI adapter is missing. In that situation, replace the system board (the SCSI controller is built into the board).

If a SCSI device is missing from the list, determine if the missing device is connected to the SCSI controller on the system board, or a SCSI adapter. Either the system board or the SCSI adapter might be defective. Continue with the following procedure.

1. Power-off the computer and disconnect any internal and external SCSI devices from the computer (except default drive 6, if installed).
2. If the device is connected to a SCSI adapter, install the external terminator if no external SCSI devices are attached (some SCSI adapters have both an internal and an external terminator).

Notes:

- a. Some system boards with SCSI have terminators built in and do not require a terminator.
 - b. For more information, see "Terminator Function" on page 414.
3. Power-on the computer and run **Automatic Configuration**. If the SCSI adapter (or the SCSI controller on the system board) is not on the Devices List in Advanced Diagnostics, it is defective. If the SCSI adapter (or the SCSI controller on the system board) is on the list, run the SCSI adapter or SCSI controller Advanced Diagnostic test.
 4. If the SCSI adapter (or the SCSI controller on the system board) fails the test, replace it. If it passes the test, a different adapter or device might be causing the problem; if this is the case, continue with the next step.

5. Disconnect SCSI default drive 6, then re-run Advanced Diagnostics. If the SCSI adapter or the system board fails, replace the FRU. If the problem is not found, continue with the next step.
6. Reconnect all the devices, then put all terminators back in the same positions they were in before service.
7. Use the procedure in “Undetermined Problems” on page 183 to find the problem.

Missing SCSI and Non-SCSI Devices

If both types of devices are missing, see “Related Service Information” on page 107 to find the problem.

System Error Log

If you are not familiar with the error log, refer to “System Error Log” on page 433.

Notes:

1. On 90 and 95, only systems with a Type 3 processor board (submodel codes 28, 29, 36, 37) support the system error log.
2. After service, clear any noninformational errors from the error log.

Viewing the System Error Log

1. Go to the Main Menu.
2. Select **More Utilities**.
3. Select **Display system error log**.
4. Follow the instructions on the screen.

Read the error log to see if any errors are stored. Use that information to help determine what is causing the failure.

If you cannot find the problem using the error log, run diagnostics, if you have not already done so.

Symptom-to-FRU Index (Micro Channel)

This index supports the following PS/2 Models:

50, 55, 56, 57, 60, 65, 70, 76, 77, 80, 85, 90, and 95.
Always start with "General Checkout (Micro Channel)"
on page 19.

For information on:	Go to:
Additional service help. (For example, voltage checks, OS/2 Trap errors, or processor board errors)	"Related Service Information" on page 107.
Possible software and hardware mismatch problems. (not repairable by replacing FRUs)	"Software/Hardware Mismatch Problems" on page 181.
Starting the System Programs	"Starting System Program Diagnostics" on page 425.
Erasing Power-On Passwords	"Removing a Power-On Password" on page 376.
Privileged Access Password Jumper (9556, 9557)	"Privileged-Access Password" on page 378.
Tamper Evident Switch (9556, 9557)	"Security" on page 375.
Memory Address Conflicts	"Resolving Memory-Address Conflicts" on page 408.
Replacing the system board does not correct the problem, and a removable processor is installed.	"Processor Board Installation (90, 95)" on page 135.

No-Beep Symptoms

Symptom/Error	FRU/Action
No beep, fan runs, power-on LED lights, memory may or may not count, and blinking cursor continuously loops.	<ol style="list-style-type: none"> 1. Processor Cache (90/95) 2. Processor Board
Memory count hangs during POST. (Check memory) †	<ol style="list-style-type: none"> 1. System Board Memory 2. Memory Option (if installed) 3. System Board 4. Processor
No beep, power-on indicator does not come on, and fan does not run. Important: On computers with a tamper evident switch, when the cover is off, the switch must be in the "up" or "on" position to supply power to the computer. Also, the switch might be out of adjustment (not making contact). Remove the switch and form the contacts. If this is not the problem, see "Undetermined Problems" on page 183 †	<ol style="list-style-type: none"> 1. Adapter Guide/Switch Assembly 2. Power Supply 3. Control/Speaker Assembly 4. Processor Board (90/95) 5. System Board 6. Any Device or Adapter 7. Bus Adapter
No beep, fan runs, and 000215XX is displayed. (Check memory) †	<ol style="list-style-type: none"> 1. System Board Memory 2. Processor Board (90/95) 3. System Board
No beep, fan runs, and 000258XX is displayed. (Check memory) †	<ol style="list-style-type: none"> 1. System Board
No beep, fan runs, power-on indicator is on, and computer hangs during POST with a message displayed. (See "Undetermined Problems" on page 183)†	<ol style="list-style-type: none"> 1. System Board 2. Processor Board 3. Power Supply
No beep and the computer is otherwise functional.	<ol style="list-style-type: none"> 1. Control/Speaker Assembly 2. Processor Board (90/95) 3. System Board
†	If this symbol is shown next to an error (above), go to "Related Service Information" on page 107.

Symptom/Error	FRU/Action
No beep and the computer is not functional. (See "Undetermined Problems" on page 183)†	<ol style="list-style-type: none"> 1. System Board 2. Power Supply
No beep, fan runs, power-on indicator is on, and computer hangs during POST with no message displayed. (See "Undetermined Problems" on page 183)†	<ol style="list-style-type: none"> 1. System Board 2. Processor Board (90/95) 3. Any Device or Adapter 4. Bus Adapter
† If this symbol is shown next to an error (above), go to "Related Service Information" on page 107.	

Beep Symptoms

Symptom/Error	FRU/Action
One long and one short beep. (Check display) †	<ol style="list-style-type: none"> 1. Display Adapter (any type) 2. System Board 3. Video Memory (if used) 4. Bus Adapter 5. Power Supply
One long and two short beeps. (Check display) †	<ol style="list-style-type: none"> 1. Display Adapter (any type) 2. Video Memory (if used) 3. System Board 4. Adapter Video Memory 5. Bus Adapter 6. ACPA/A Adapter 7. Power Supply
One or two beeps and a blank or unreadable display, or a blinking cursor. (Check display) †	<ol style="list-style-type: none"> 1. Display Adapter (any type) 2. Video Memory (if used) 3. System Board 4. Adapter Video Memory 5. Display (any type) 6. Bus Adapter 7. ACPA/A Adapter
Continuous beep.	<ol style="list-style-type: none"> 1. System Board 2. Power Supply
Continuous beep and a blank display. (Check display).	<ol style="list-style-type: none"> 1. Display Adapter 2. Video Memory (if used) 3. System Board
One long and three short beeps. (Check display)	<ol style="list-style-type: none"> 1. Display Adapter 2. Video Memory (if used) 3. System Board
Repeating short beeps. (Check the keyboard for a stuck key)	<ol style="list-style-type: none"> 1. System Board 2. ACPA/A Adapter
†	If this symbol is shown next to an error (above), go to "Related Service Information" on page 107.

Audio Symptoms

Symptom/Error	FRU/Action
Front microphone and front headphone inoperative and rear microphone, rear headphone, and computer beeps are working properly.	<ol style="list-style-type: none"> Control Panel Assembly Cable (system board to control panel assembly)
Front microphone, front headphone, and computer beeps inoperative and rear microphone and rear headphone are working properly.	<ol style="list-style-type: none"> Control Panel Assembly Cable (system board to control panel assembly)
Distorted or missing audio from control panel assembly line outputs or headphone jack.	<ol style="list-style-type: none"> ACPA/A Adapter
Front microphone inoperative and rear microphone works properly.	<ol style="list-style-type: none"> Control Panel Assembly ACPA/A Adapter Cable (ACPA/A to control panel assembly)
Rear microphone inoperative.	<ol style="list-style-type: none"> ACPA/A Adapter Microphone
Audio from CD-ROM does not play to the front speaker, but plays to Line Output.	<ol style="list-style-type: none"> Control Panel Assembly ACPA/A Adapter Cable (ACPA/A to control panel assembly)
Audio from CD-ROM does not play to the front speaker or to Line Output.	<ol style="list-style-type: none"> CD-ROM Cable (CD-ROM to ACPA/A Adapter)

Miscellaneous Symptoms

Symptom/Error	FRU/Action
Drive letters changed unexpectedly after installing OS/2 or a SCSI adapter.	<ol style="list-style-type: none"> This is a normal condition. Use the configuration program to change the drive letters back to the desired settings.
Intermittent failures. (See "Undetermined Problems" on page 183 before replacing FRUs) †	<ol style="list-style-type: none"> Power Supply Power Supply Fans Any Device or Adapter
Diskette drive LED stays on.	<ol style="list-style-type: none"> Diskette Drive
†	If this symbol is shown next to an error (above), go to "Related Service Information" on page 107.

Symptom/Error	FRU/Action
Hard disk LED stays on.	<ol style="list-style-type: none"> 1. Hard Disk Drive 2. System Board
Hard disk LED not working, but computer is completely functional.	<ol style="list-style-type: none"> 1. Control/Speaker Assembly 2. System Board
Reference Diskette does not start.	<ol style="list-style-type: none"> 1. Diskette Drive 2. System Board 3. Diskette Drive Cable 4. Reference Diskette
Read / write errors on a 2.88MB diskette drive. (If the drive was just installed, either the computer has down level IML code loaded or that model does not support a 2.88MB drive.)	<ol style="list-style-type: none"> 1. Use View configuration to determine if the diskette drive is listed as a 2.88MB. If not, the latest level Reference Diskette code must be loaded onto the System Partition.
Image Adapter/A Memory Test failure indicated by graphic representation of adapter.	<ol style="list-style-type: none"> 1. Memory Module (shown in graphic)
IML image has been updated and the Diskette and F1 error prompt appears on the screen.	<ol style="list-style-type: none"> 1. Verify an operating system has been loaded onto the default hard disk.
IML image has been updated, the Diskette icon appears on the display, and a †99903XX appears on the information panel (95).	<ol style="list-style-type: none"> 1. Verify an operating system has been loaded onto the default hard disk.
Internal Data/Fax modem does not communicate with a remote modem or a fax. Note: Make sure the serial device power option is set to <i>on</i> in the Set Features program.	<ol style="list-style-type: none"> 1. Check that setup data defined by communication software is suitable for communication. 2. Internal Data/Fax Modem 3. System Board
Internal Data/Fax modem does not respond to software, and diagnostics does not find no problem.	<ol style="list-style-type: none"> 1. Check in power configuration and verify the modem is turned on.
Program load error during remote IPL from the file server.	<ol style="list-style-type: none"> 1. Network Adapter
Program loads from the hard disk or a non system disk or disk error (with the Reference Diskette in drive A).	<ol style="list-style-type: none"> 1. Diskette Drive 2. System Board 3. Power Supply 4. Reference Diskette
†	If this symbol is shown next to an error (above), go to "Related Service Information" on page 107.

Symptom/Error	FRU/Action
No colors on a color display. (Connect display to the VGA port and run the Enhanced VGA test to see if the display is the problem)	<ol style="list-style-type: none"> 1. Display (any type) 2. VGA terminator
Screen colors change.	<ol style="list-style-type: none"> 1. Display (any type) 2. Display Adapter 3. System Board
One or more keys do not work and the computer is otherwise functional. (Check keyboard) †	<ol style="list-style-type: none"> 1. Keyboard 2. Keyboard Cable 3. System Board
Power supply <i>appears</i> to fail at power-on, but if you disconnect optional hard disks, the problem goes away (load problem). (See "Setting the Motor-Start Jumper" on page 414)	<ol style="list-style-type: none"> 1. Motor Start Jumper (Remove the motor start start jumper from one or more option drives.)
Power-on indicator does not come on, fan runs, and computer is functional.	<ol style="list-style-type: none"> 1. Control/Speaker Assembly
Power-on indicator does not come on, fan runs, and computer is not functional.	<ol style="list-style-type: none"> 1. System Board 2. Power Supply
Power-on indicator does not come on, fan not running, and computer is not functional. (See "Undetermined Problems" on page 183 before replacing FRUs) †	<ol style="list-style-type: none"> 1. Power Supply 2. System Board
Operating system does not work, or the system starts up in BASIC. (See "IML and IPL Errors" on page 55 before replacing FRUs)	<ol style="list-style-type: none"> 1. Default Hard Disk Drive
Real Time Clock loses time. (This is not always a hardware failure. See "Real-Time Clock Problems" on page 150)	<ol style="list-style-type: none"> 1. Default Hard Disk Drive
Computer cannot be powered-off.	<ol style="list-style-type: none"> 1. Control/Speaker Assembly 2. System Board 3. Power Supply
†	If this symbol is shown next to an error (above), go to "Related Service Information" on page 107.

Numeric Error Codes

Symptom/Error	FRU/Action
000101XX (Interrupt failure. Possibly a bad battery or processor)	<ol style="list-style-type: none"> 1. Run Advanced Diagnostics 2. 486DX33 Upgrade (70/80)
000102XX (ROM checksum or timer error. Possibly a bad battery or processor) (If the battery was removed while replacing the 80386 processor in a Model 70, with a 486DX33 Processor Upgrade (FRU Number 92F0436), remove the 486DX33 processor and install the 80386 processor; then, install the battery. Configure the system and re-install the 486DX33 processor without removing the battery.)	<ol style="list-style-type: none"> 1. Run Advanced Diagnostics 2. 486DX33 Upgrade (70/80)
00010300 (Checksum or timer error. If it is a 20-MHz board, and the processor is not a 487SX, the jumper must be in positions 2 and 3) (487SX is indicated on the processor)	<ol style="list-style-type: none"> 1. Processor Board (90/95) 2. System Board
000102XX, 000103XX 000104XX, 000107XX	<ol style="list-style-type: none"> 1. System Board 2. Processor Board
000105XX (Command not accepted)	(Information only)
000106XX (Converting logic test failure)	<ol style="list-style-type: none"> 1. Run Advanced Diagnostics
000107XX, 000108XX 000109XX (Interrupt or memory failure)	<ol style="list-style-type: none"> 1. System Board Memory 2. System Board 3. Processor Board (90/95) 4. Any Adapter 5. Bus Adapter
00010XXX	<ol style="list-style-type: none"> 1. System Board
000110XX (Check memory) † (For Model 95, also see 000201XY for socket location list)	<ol style="list-style-type: none"> 1. Memory Module Kit 2. System Board
†	If this symbol is shown next to an error (above), go to "Related Service Information" on page 107.

Symptom/Error	FRU/Action
000111XX	<ol style="list-style-type: none"> 1. Adapter Memory 2. Expansion Adapter 3. System Board
000112XX, 000113XX (Possible timeout error)	<ol style="list-style-type: none"> 1. System Board 2. Processor Board (90/95)
000114XX (ROM error)	<ol style="list-style-type: none"> 1. Any Adapter 2. Bus Adapter
000115XX (80386 protect mode failure, or BIOS checksum error)	<ol style="list-style-type: none"> 1. System Board 2. 486DX33 Upgrade (70/80)
000116XX (Possible read/write problem)	<ol style="list-style-type: none"> 1. Run Advanced Diagnostics 2. 486DX33 Upgrade (70/80)
000118XX (Previously detected error. Run Advanced Diagnostics)	<ol style="list-style-type: none"> 1. System Board Memory 2. Processor Board (90/95)
000119XX	<ol style="list-style-type: none"> 1. Run Automatic Configuration (2.88MB diskette drive is installed but not supported.) 2. System Board
00011XXX (not listed above)	<ol style="list-style-type: none"> 1. System Board
000120XX (Possible processor self test failure)	<ol style="list-style-type: none"> 1. System Board Processor Cache (90/95) Processor Board (90/95)
000121XX (A problem was detected during memory remapping)	(Information only)
00012201, 00012202 00012203, 00012204 00012205, 00012206 00012207, 00012208 (Data error. Possible system board failure)	<ol style="list-style-type: none"> 1. Run Advanced Diagnostics
000129XX	<ol style="list-style-type: none"> 1. Processor Board 2. Cache Kit 3. System Board
00013000 (POST could not start the operating system. Operating system loaded? Is the boot drive in the selectable drive sequence?)	<ol style="list-style-type: none"> 1. Check Drive Sequence
†	If this symbol is shown next to an error (above), go to "Related Service Information" on page 107.

Symptom/Error	FRU/Action
00013001 (Security system is being used, but the computer is not totally secured because there is a diskette drive in the startup sequence)	1. Delete diskette drive from the startup sequence if so desired.
00013002 (Drive startup sequence is corrupt or invalid)	1. Run Automatic Configuration Then reset the selectable drive startup sequence. If the problem still exists, replace the system board.
00013003 (EEPROM could not be read)	1. Run Automatic Configuration If the problem still exists, replace the system board.
000131XX	1. System Board
000132XX (DMA extended registers error)	1. Run Advanced Diagnostics
000133XX (DMA verify function error. Logic failed)	1. Run Advanced Diagnostics
000134XX (DMA arbitration logic error)	1. Run Advanced Diagnostics
00014905	1. System Board 2. Processor Board
00014908, 00014909 Before replacing any FRUs, see "Cover Lock and Tamper-Evident Switches" on page 375	1. System Board 2. Tamper Evident Switches 3. Keylock Assembly
000152XX (Real time clock error. (This is not always a hardware failure. Also see "Real-Time Clock Problems" on page 150)	1. Run Advanced Diagnostics
000156XX (Security error. The covers were removed without using the key. The tamper evident switch was tripped)	1. Start the system from the Reference Diskette (or server image) and reconfigure the system. 2. Security Switch Assembly 3. System Board
†	If this symbol is shown next to an error (above), go to "Related Service Information" on page 107.

Symptom/Error	FRU/Action
000160XX (System Board ID not recognized. Possible system board failure)	1. Run Advanced Diagnostics
000161XX CAUTION: The lithium battery (IBM part number 33F8354) in your computer presents a fire, explosion, or severe burn risk. Use of another battery could result in ignition or explosion of the battery.	1. Battery 2. Processor Board (90/95) 3. System Board 4. Bus Adapter
000162XX (Be sure all devices are powered-on. (Check Enable/Disable settings) † Configuration changed? If so, run Automatic Configuration.	1. Any Device 2. Battery
00016300 (Date and time error)	1. Set Date and time
00016000, 00016400 00016500, 00016700 00016900 (If setting configuration, date, and time does not solve the problem, see "Devices List" on page 23)	1. Set Configuration, Features 2. System Board
000166XX (Reseat all adapters)	1. Run Advanced Diagnostics
000168XX (Real time clock error. This is not always a hardware failure. Also see "Real-Time Clock Problems" on page 150)	1. Run Advanced Diagnostics
000169XX Processor configuration error. (Run Automatic Configuration, then verify that the processor configuration information is correct before replacing FRUs)	1. Processor Board 2. System Board
000170XX (ASCII console setup conflict error. The serial port is disabled)	1. From "Set Configuration," select "Change Configuration," and enable the port.
†	If this symbol is shown next to an error (above), go to "Related Service Information" on page 107.

Symptom/Error	FRU/Action
000171XX	<ol style="list-style-type: none"> Battery Processor Board (90/95) System Board Bus Adapter
000172XX	<ol style="list-style-type: none"> System Board
000173XX (Possibly a weak battery)	<ol style="list-style-type: none"> Set Configuration/Features
000174XX (If the configuration has been changed, run Automatic Configuration. Otherwise, run Advanced Diagnostics) (Check "SCSI Device Default Settings" on page 180) †	<ol style="list-style-type: none"> Any Device System Board Bus Adapter
000175XX (Security error. The system board EEPROM failed)	<ol style="list-style-type: none"> System Board
000176XX (Security error. The covers were removed without using the key. The tamper evident switch was tripped)	<ol style="list-style-type: none"> Start the system from the Reference Diskette (or server image) and reconfigure the system. Security Switch Assembly System Board
000177XX, 000178XX (Security error. Passwords corrupted) Reset.	<ol style="list-style-type: none"> System Board
000179XX (System error log might be full)	<ol style="list-style-type: none"> Go into the log and note the errors. Clear the log, then run Advanced Diagnostics
000181XX (The computer requires a network adapter for remote IPL or a hard disk drive ID of 6 LUN 0, for IML; neither of these were detected)	<ol style="list-style-type: none"> Run Automatic Configuration Network Adapter Hard Disk Drive System Board
000182XX (Privileged access password (PAP) data is corrupted. To restore it, move jumper JMP2 to position "0" write enabled).	(Information only)
000183XX (Wrong password entered)	<ol style="list-style-type: none"> Enter the Privileged access password (PAP) instead of the power-on password.
†	If this symbol is shown next to an error (above), go to "Related Service Information" on page 107.

Symptom/Error	FRU/Action
000184XX (Power-on password corrupted)	1. User must reset the password.
000185XX (Selectable startup sequence corrupted)	1. Run Select Startup Sequence utility. Reset user's chosen startup sequence.
000186XX (Security error. Hardware failed)	1. System Board
000187XX (Vital Product Data (VPD) error. System serial number information corrupted)	1. Select Set system identification from the Reference Diskette, System Partition (or server image) and type the system serial number. If problem remains, suspect the system board.
000188XX (Vital Product Data (VPD) error)	1. Run Automatic Configuration
000189XX (The wrong password was entered 3 times. Clear the system error log and restart the system)	(Information only)
000191XX (82385 cache test failed)	1. Run Advanced Diagnostics
000194XX	1. System Board Memory 2. Memory Riser Card (90) 3. Memory Module Kit
000199XX (User indicated configuration is invalid)	1. Run the Flash Update Utility (PS/2 9553-xBx Only) 2. System Board
0001XXXX (not listed above)	1. System Board Processor Board (90/95) 2. 486DX33 Upgrade (70/80) 3. Any Adapter 4. Bus Adapter
000201XX to 000205XX (Reseat System Board Memory)	1. System Board Memory 2. System Board
†	If this symbol is shown next to an error (above), go to "Related Service Information" on page 107.

Symptom/Error	FRU/Action
00020XXY, 000217XY (If the "Y" digit is in the range "G" to "V", suspect the model 90/95 processor board first) † (See page 126)	<ol style="list-style-type: none"> 1. System Board Memory Memory Riser Card (90) Processor Board (90/95) 2. System Board
000210XX, 000211XX (Check memory) †	<ol style="list-style-type: none"> 1. Processor Board (90/95) 2. System Board Memory 3. Memory Riser Card (90) 4. System Board
000214XX, 000215XX 000216XX, 000221XX 000226XX, 000240XX 000235XX, 000241XX (Check memory. It might be the wrong type or in the wrong slot) †	<ol style="list-style-type: none"> 1. System Board Memory Memory Riser Card (90) System Board Processor Board (90/95) 2. Bus Adapter
000225XX (Check memory. It might be the wrong type or wrong speed) †	<ol style="list-style-type: none"> 1. System Board Memory Memory Riser Card (90) System Board Processor Board (90/95) 2. Bus Adapter
000221XX (ROM to RAM parity error)	<ol style="list-style-type: none"> 1. System Board
000231XX	<ol style="list-style-type: none"> 1. Expanded Memory Option
00024300, 00024400	<ol style="list-style-type: none"> 1. Processor Board (90/95)
000245XX, 000246XX (Check memory) †	<ol style="list-style-type: none"> 1. Processor Board 2. Memory Riser Card (90) 3. System Board 4. System Board Memory
00024700	<ol style="list-style-type: none"> 1. Processor Board (90/95)
000251XX (Memory location changed on the memory expansion option)	(Information only)
00025200	<ol style="list-style-type: none"> 1. Processor Board (90/95) 2. System Board
†	If this symbol is shown next to an error (above), go to "Related Service Information" on page 107.

Symptom/Error	FRU/Action
000253XX, 000254XX	<ol style="list-style-type: none"> 1. Processor Cache (90/95) 2. Processor Board
000255XX (Check memory) †	<ol style="list-style-type: none"> 1. System Board Memory 2. System Board
00029000 (Unsupported memory combination detected) †	<ol style="list-style-type: none"> 1. Correct the unsupported combination of ECC and parity memory modules. Run Automatic Configuration, then rerun Advanced Diagnostics
000291XX, 000292XX 000293XX, 00029400 (Checksum value mismatch)	<ol style="list-style-type: none"> 1. Run Automatic Configuration then rerun Advanced Diagnostics
000295XX, 000296XX (Check memory for an unsupported configuration or modules) †	<ol style="list-style-type: none"> 1. System Board Memory
00029800 (Checksum value mismatch)	<ol style="list-style-type: none"> 1. System Board Memory Run Automatic Configuration then rerun Advanced Diagnostics
0002XX00 (not listed above)	<ol style="list-style-type: none"> 1. 486DX33 Upgrade (70/80)
000301XX, 000302XX	<ol style="list-style-type: none"> 1. Keyboard Cable 2. System Board
000303XX, 000304XX	<ol style="list-style-type: none"> 1. System Board 2. Keyboard 3. Keyboard Cable
000305XX (Keyboard voltage error. If no fuse in system, replace system board) †	<ol style="list-style-type: none"> 1. Fuse 2. Keyboard Cable
000306XX (Wrong Keyboard Attached?)	<ol style="list-style-type: none"> 1. Check for Unsupported Keyboard
000307XX	<ol style="list-style-type: none"> 1. Keyboard 2. Keyboard Cable
000320XX	<ol style="list-style-type: none"> 1. System Board
000401XX to 000405XX	<ol style="list-style-type: none"> 1. System Board
0005XXXX	<ol style="list-style-type: none"> 1. Display Adapter (any type)
†	If this symbol is shown next to an error (above), go to "Related Service Information" on page 107.

Symptom/Error	FRU/Action
000601XX	<ol style="list-style-type: none"> 1. Defective Diskette 2. Diskette Drive 3. System Board
000602XX (Invalid boot record)	<ol style="list-style-type: none"> 1. Defective Diskette
000604XX (Unsupported drive or cable. Drive must be media sense type)	<ol style="list-style-type: none"> 1. Diskette Drive 2. System Board 3. Diskette Drive Cable
000605XX (Diskette drive error)	<ol style="list-style-type: none"> 1. Run Advanced Diagnostics
000606XX, 000607XX 000610XX, 000621XX 000622XX, 000623XX 000624XX, 000630XX 000631XX, 000632XX 000633XX, 000640XX 000641XX, 000642XX 000643XX, 000650XX 000651XX, 000652XX 000653XX, 000654XX 000656XX, 000657XX 000658XX, 000659XX 000660XX (Generally, these are media errors. Try a known good diskette. If the error appears again, replace the drive.	<ol style="list-style-type: none"> 1. Diskette 2. Diskette Drive 3. System Board
000655XX	<ol style="list-style-type: none"> 1. System Board
000662XX (Wrong drive type installed)	(Information only)
000663XX (Wrong media type in the drive)	(Information only)
000668XX	<ol style="list-style-type: none"> 1. Diskette Drive
0006XXXX (not listed above)	<ol style="list-style-type: none"> 1. Diskette Drive 2. System Board 3. Diskette Drive Cable
0007XXXX For a 486 processor, erase COPROC.DGS from the backup Reference Diskette, then restore the system partition from the corrected backup Reference Diskette. Re-run Advanced Diagnostics.	<ol style="list-style-type: none"> 1. Math Coprocessor 2. 486DX33 Upgrade (70/80) 3. System Board
00100203	<ol style="list-style-type: none"> 1. System Board
†	If this symbol is shown next to an error (above), go to "Related Service Information" on page 107.

Symptom/Error	FRU/Action
00110100 (Serial connector error, possible system board failure)	1. Run Advanced Diagnostics
001101XX, 00110200 00110600, 00110800 00110900	1. System Board 2. Any Serial Device
00110700	1. Communications Cable 2. System Board
001102XX (Card selected feedback error)	1. Run Advanced Diagnostics
001103XX (Port fails register check)	1. Run Advanced Diagnostics 2. System Board
001106XX (Serial option cannot be turned off)	1. Run Advanced Diagnostics 2. System Board
001107XX	1. Serial Device Cable 2. System Board
001110XX (Register test failed)	1. Run Advanced Diagnostics 2. System Board
001116XX (16550 interrupt error)	1. Run Advanced Diagnostics
001117XX (Failed baud rate test)	1. Run Advanced Diagnostics
0011XXXX (not listed above) (See "Power Supply Voltage Check" on page 138 before replacing system board) †	1. System Board
001201XX (Check voltages) †	1. System Board 2. Any Serial Device
001202XX, 001206XX 001208XX, 001209XX 0012XXXX	1. Dual Async Adapter/A 2. System Board 3. Any Serial Device
001207XX	1. Communications Cable 2. Dual Async Adapter/A
00129020 (Disk cache error)	1. Cached Processor Option 2. System Board
001301XX, 001302XX	1. Game Adapter 2. Joystick
001402XX (Printer not ready)	(Information only)
†	If this symbol is shown next to an error (above), go to "Related Service Information" on page 107.

Symptom/Error	FRU/Action
001403XX (No paper error, or interrupt failure)	(Information only)
001404XX (System board timeout failure)	1. Run Advanced Diagnostics
001405XX (Parallel adapter error)	1. Run Advanced Diagnostics
001406XX (Presence test error)	1. Run Advanced Diagnostics
0014XX00 (not listed above) (Check printer before replacing system board) †	1. Printer 2. System Board
001701XX, 001703XX 001704XX, 001714XX 0017XXXX (Not listed below)	1. Hard Disk Drive 2. Cable (ST506) 3. Hard Disk Adapter (ST506) 4. System Board 5. Power Supply
001702XX	1. Hard Disk Adapter
001705XX, 001706XX 001707XX, 001708XX 001710XX, 001711XX 001712XX, 001713XX 001715XX, 001716XX 001717XX, 001726XX 001735XX, 001750XX 001751XX, 001752XX 001753XX, 001754XX 001755XX, 001757XX 001780XX, 001781XX 001782XX, 001790XX 001791XX (Read/write problem. Be sure the drive type is supported. If it is, try a low level format. If the error continues, replace the hard disk drive)	1. Format the Drive 2. Hard Disk Drive
00180100 to 00180700	1. System Board
00186XXX	1. Set Configuration/Features 2. Battery
0018XXXX (not listed above)	1. System Board Expansion Unit
00240100, 00240200 (If screen colors change)	1. Display (any type)
00240100, 00240200 (If screen colors are OK)	1. System Board 2. Display (any type)
† If this symbol is shown next to an error (above), go to "Related Service Information" on page 107.	

Symptom/Error	FRU/Action
00240900	1. Display (any type)
00241000	1. System Board
003015XX (Check for missing wrap or terminate plug on the adapter)	1. Baseband Adapter 2. Baseband Cable
0037XXXX (This is usually caused by the SCSI controller built into the system board)	1. System Board 2. Hard Disk Drive 3. Hard Disk Cable
004611XX, 004630XX	1. Multiport/2 Interface Board 2. Multiport/2 Adapter
004612XX, 004613XX 004640XX, 004641XX	1. Memory Module Package 2. Multiport/2 Adapter
00465000	1. Multiport Interface Cable
0046XXXX (not listed above)	1. Multiport/2 Adapter 2. Multiport/2 Interface Board 3. Memory Module Package
005600XX	1. Financial System 2. Controller Adapter
0062XXXX	1. 1st Store Loop Adapter 2. Adapter Cable
0063XXXX	1. 2nd Store Loop Adapter 2. Adapter Cable
0064XXXX (See "Network Service Procedures" on page 74)	1. Network Adapter
0071XXXX	1. Voice Adapter
0074XXXX (Adapter jumper in the correct position? See "Display Adapter 8514/A" on page 109)	1. 8514/A Display Adapter 8514/A Memory Module 2. System Board
007509XX (Check display) †	1. Display Adapter (any type) 2. Display (any type) 3. System Board 4. Video Memory
007510XX (Check display) †	1. XGA Adapter 2. Video Memory
0076XXXX	1. Page Printer Adapter
0078XXXX	1. High Speed Adapter
†	If this symbol is shown next to an error (above), go to "Related Service Information" on page 107.

Symptom/Error	FRU/Action
0079XXXX	1. 3117 Adapter
008001XX to 008012XX (System Board Upgrade Model 50, 55 Only)	1. Pointing Device (Mouse) 2. System Board
00850XXX, 00851XXX	1. 80286 Memory Option Adapter/A 2. System Board
00852XXX	1. Memory Module Package on the 80286 Memory Adapter/A 2. Adapter Memory 3. System Board
008601XX, 008602XX	1. Pointing Device (Mouse) 2. System Board
008603XX, 008604XX	1. System Board 2. Pointing Device (Mouse)
0089XXXX	1. Music Adapter
0091XXXX	1. Optical Drive 2. Adapter
0096XXXX (This adapter has cache)	1. SCSI Adapter 2. Any SCSI Device 3. System Board
010001XX (Multiprotocol Adapter/A not found)	(Information only)
010002XX (Card selected feedback error)	1. Run Advanced Diagnostics
010007XX	1. Communications Cable 2. Multiprotocol Adapter/A
010008XX, 010009XX	1. Multiprotocol Adapter/A 2. Any Serial Device
0100XXXX (not listed above)	Multiprotocol Adapter/A 1. System Board 2. Bus Adapter
0101102X, 0101106X 0101108X, 0101109X	1. Modem Adapter/A 2. Data/Fax Modem 3. Any Serial Device
†	If this symbol is shown next to an error (above), go to "Related Service Information" on page 107.

Symptom/Error	FRU/Action
010101XX, 010102XX 010104XX, 010105XX 010106XX, 010107XX 010108XX, 010109XX 010111XX, 010112XX 010113XX, 010114XX 010115XX, 010116XX	<ol style="list-style-type: none"> 1. Have the customer verify that the correct operating system device drivers are installed and operational 2. Modem
010103XX, 010110XX 0101171X	<ol style="list-style-type: none"> 1. System Board 2. Data/Fax Modem
010117XX (not listed above)	<ol style="list-style-type: none"> 1. Check system speaker 2. Check PSTN cable 3. External DAA (if installed) 4. Modem
010118XX	<ol style="list-style-type: none"> 1. Run System Diagnostics and verify the correct operation of the modem slot 2. Modem
010119XX	<ol style="list-style-type: none"> 1. Diagnostics detected a non-IBM modem 2. Modem
010120XX	<ol style="list-style-type: none"> 1. Check PSTN Cable 2. External DAA (if installed) 3. Modem
010132XX, 010133XX 010134XX, 010135XX 010136XX, 010137XX 010138XX, 010139XX 010140XX, 010141XX 010142XX, 010143XX 010144XX, 010145XX 010146XX, 010147XX 010148XX, 010149XX 010150XX, 010151XX 010152XX	<ol style="list-style-type: none"> 1. Modem
010153XX	<ol style="list-style-type: none"> 1. Data/Fax Modem 2. System Board
0101XXXX (not listed above)	<ol style="list-style-type: none"> 1. Modem Adapter/A 2. Data/Fax Modem 3. System Board
010450XX, 010451XX 010490XX, 010491XX 010492XX, 010499XX (Read/write error)	<ol style="list-style-type: none"> 1. Run Advanced Diagnostics 2. Riser Card (if installed) 3. Hard Disk Drive 4. System Board
010452XX (Seek test error)	<ol style="list-style-type: none"> 1. Run Advanced Diagnostics
†	If this symbol is shown next to an error (above), go to "Related Service Information" on page 107.

Symptom/Error	FRU/Action
010453XX (Wrong drive type?)	(Information only)
010454XX (Sector buffer test error)	1. Run Advanced Diagnostics
010455XX, 010456XX (Controller error)	1. Run Advanced Diagnostics
010459XX (Drive diagnostic command error)	(Information only)
010461XX (Drive format error)	1. Run Advanced Diagnostics
010462XX (Controller seek error)	1. Run Advanced Diagnostics
010464XX (Hard Drive read error)	1. Run Advanced Diagnostics
010467XX (Drive non fatal seek error)	1. Run Advanced Diagnostics
010468XX (Drive fatal seek error)	1. Run Advanced Diagnostics
010469XX (Drive soft error count exceeded)	1. Run Advanced Diagnostics
010470XX, 010471XX 010472XX (Controller wrap error)	1. Run Advanced Diagnostics
010473XX (Corrupt data. Low level format might be required)	(Information only)
010480XX	1. Hard Disk Drive (ESDI) 2. Drive Cable 3. Controller 4. System Board
010481XX (ESDI drive D seek error)	1. Run Advanced Diagnostics
010482XX (Drive select acknowledgement bad)	1. Run Advanced Diagnostics
010490XX, 010491XX (Drive 0,1 read error)	1. Run Advanced Diagnostics 2. Riser Card (if installed) 3. Hard Disk Drive 4. System Board
010499XX (Drive controller error)	1. Run Advanced Diagnostics 2. Riser Card (if installed) 3. Hard Disk Drive 4. System Board
†	If this symbol is shown next to an error (above), go to "Related Service Information" on page 107.

Symptom/Error	FRU/Action
010483XX	<ol style="list-style-type: none"> 1. Hard Disk Adapter (ESDI) 2. System Board
0104XXXX (not listed above)	<ol style="list-style-type: none"> 1. Hard Disk Drive 2. Hard Disk Adapter (ESDI) 3. Hard Disk Cable 4. Power Supply
0106XXXX (See "Network Service Procedures" on page 74)	<ol style="list-style-type: none"> 1. Ethernet Network Adapter/A 2. System Board 3. Bus Adapter
0107XXXX	<ol style="list-style-type: none"> 1. 5.25-inch External Diskette Drive 2. 5.25-inch Diskette Drive Adapter/A
0109XXXX (Check the adapter cables)	<ol style="list-style-type: none"> 1. ActionMedia Adapter/A 2. System Board
0112XXXX (This adapter does not have cache)	<ol style="list-style-type: none"> 1. SCSI Adapter 2. Any SCSI Device 3. System Board
0119XXXX	<ol style="list-style-type: none"> 1. 3119 Adapter
0121XXXX	<ol style="list-style-type: none"> 1. 300/1200/2400 Modem/A 2. Any Serial Device 3. System Board
01290001 01290002 01290003 01290004 01290007 01290008 (Possibly a recoverable processor board error)	<ol style="list-style-type: none"> 1. Run Advanced Diagnostics
01290050, 01290051 01290052, 01290053 01290054, 01290055 01290056 (Probably a fatal error)	<ol style="list-style-type: none"> 1. Processor Board 2. System Board
01290100, 012902XX 01290400, 01290700 01290800 (Cache error)	<ol style="list-style-type: none"> 1. Processor Board 2. System Board Cache 3. System Board
012903XX (Math coprocessor error)	<ol style="list-style-type: none"> 1. Math Coprocessor 2. Processor Board
01290XXX (not listed above)	<ol style="list-style-type: none"> 1. Processor Cache (90/95) 2. Processor Board 3. System Board
†	If this symbol is shown next to an error (above), go to "Related Service Information" on page 107.

Symptom/Error	FRU/Action
01291200, 01291300 01291400, 012915XX 012916XX, 01291800 01291900, 01294040 01294041 (Possible processor board error)	1. Run Advanced Diagnostics
01291700 (If it is a 20-MHz board, and the processor is a 487SX, the jumper must be in positions 1 and 2) (487SX is indicated on the processor)	1. Processor Board (90/95)
01293000 (90/95 Processor board EEPROM jumper is in the wrong position)	1. Jumpered Incorrectly 2. Processor Board
01294042 (POST / BIOS EEPROM error. Update diskette is required)	1. Processor Board
01294400 (A hardware default interrupt occurred)	1. Restart the system then run advanced diagnostics
01295050, 01295056 01295060, 01295061 01295070, 01295071 01295072, 01295073 01295074, 01295075 01295076, 01295077 01295078, 01295079 01295080, 01295081 01295082, 01295083 01295085, 01295086 01295087, 01295088 01295090, 01295091 01295094, 01295095 01295096, 01295097 (Processor board errors)	1. Restart the system then run advanced diagnostics
0129X300 (Busmaster arbitration error. If more than one is installed, remove them one at a time to isolate the failure)	1. Busmaster Adapter (90/95) 2. Processor Board
01299000 (VPD error; processor board replaced? Processor board serial number detected does not match serial number stored)	1. Run Automatic Configuration
0136XXXX	1. ISDN Primary Rate Adapter 2. System Board
†	If this symbol is shown next to an error (above), go to "Related Service Information" on page 107.

Symptom/Error	FRU/Action
0137XXXX	1. System Board
0141XXXX	1. Realtime Interface Coprocessor Portmaster Adapter/A
0143XXXX	1. Japanese Display Adapter 2. System Board
01471000, 014711XX	1. System Board Display Adapter (any type) 2. Adapter Video Memory
0148XX00	1. Display Adapter (any type)
014901XX, 014902XX 01491XXX, 014922XX	1. Display Adapter (any type) 2. System Board 3. Display (any type)
014932XX	1. External Display (any type) 2. Display Adapter (any type)
0152XXXX	1. XGA Display Adapter/A 2. System Board
0161XXXX	1. FaxConcentrator Adapter
0164XXXX	1. 120MB Internal Tape Drive 2. Diskette Cable 3. System Board
016500XX	1. 6157 Tape Attachment Adapter
016520XX, 016540XX	1. 6157 Streaming Tape Drive 2. 6157 Tape Attachment Adapter
0166XXXX, 0167XXXX (See "Network Service Procedures" on page 74)	1. Token-Ring Network Adapter/A 2. System Board 3. Bus Adapter
018001XX (18001 to 18029)	1. Wizard Adapter 2. Wizard Adapter Memory
018031XX (18031 to 18039)	1. Wizard Adapter Cable
018441XX (Unsupported memory module on 80386 adapter)	(Information only)
†	If this symbol is shown next to an error (above), go to "Related Service Information" on page 107.

Symptom/Error	FRU/Action
018451XX (Need to reconfigure. Module changed on on 80386 adapter)	(Information only)
0184XXXX	1. Enhanced 80386 Memory Adapter/A
0185XXXX	1. DBCS Japanese Display Adapter/A 2. System Board
0194XXXX	1. Memory Module package on the 2-8MB 80286 Memory Adapter 2. Memory adapter 3. System Board
020001XX to 020003XX	1. Image Adapter/A Image-I Adapter/A 2. Memory Module DRAM, VRAM
020004XX	1. Memory Module DRAM, VRAM 2. Image Adapter/A Image-I Adapter/A
020005XX to 020010XX	1. Image Adapter/A Image-I Adapter/A 2. Memory Module DRAM, VRAM
0200XXXX (not listed above)	1. Image Adapter/A Image-I Adapter/A 2. Memory Module DRAM, VRAM 3. System Board
020101XX to 020103XX	1. Printer/Scanner Option 2. Image Adapter/A 3. Memory Module DRAM, VRAM
020104XX	1. Memory Module DRAM, VRAM 2. Printer/Scanner Option 3. Image Adapter/A
020105XX to 020110XX	1. Printer/Scanner Option 2. Image Adapter/A 3. Memory Module DRAM, VRAM
Image Adapter/A Memory Test failure indicated by graphic representation of adapter	1. Replace memory module (shown in graphic)
†	If this symbol is shown next to an error (above), go to "Related Service Information" on page 107.

Symptom/Error	FRU/Action
0206XXXX	<ol style="list-style-type: none"> 1. SCSI-2 Adapter 2. Any SCSI Device 3. System Board
0208XXXX (Verify that there are no duplicate SCSI ID settings on the same bus)	<ol style="list-style-type: none"> 1. Any SCSI Device
0210XXXXA (60MB) 0210XXXXB (80MB) 0210XXXXC (120MB) 0210XXXXD (160MB) 0210XXXXE (320MB) 0210XXXXF (400MB) 0210XXXXG (40MB) 0210XXXXH (1GB) 0210XXXXI (104MB) 0210XXXXJ (212MB) 0210XXXXM (2GB, 8 bit, 68-pin) 0210XXXXN (540MB) 0210XXXXO (1GB) 0210XXXXQ (540MB) 0210XXXXP (2GB, 8 bit, 50-pin) 0210XXXXU (Size unknown) (If it is an external device, check the external voltages. See "SCSI Diagnostic Tests" on page 181 and "SCSI ID (Using to Help Isolate Failures)" on page 181 before replacing any FRUs) †	<ol style="list-style-type: none"> 1. SCSI Hard Disk Drive 2. SCSI Adapter or the SCSI controller built into the system board. 3. SCSI Cable 4. SCSI ID Switch (On some models)
0210XXXX (Internal bus, size unknown) 0210XXXX1 (External bus, size unknown)	<ol style="list-style-type: none"> 1. SCSI Hard Disk Drive 2. SCSI Adapter or the SCSI controller built into the system board. 3. SCSI Cable 4. SCSI ID Switch (on some models)
The amber LED remains on.	<ol style="list-style-type: none"> 1. Tape Drive 2. SCSI Cable (internal) 3. SCSI Adapter or the SCSI controller built into the system board.
The green "in use" LED fails to come on.	<ol style="list-style-type: none"> 1. Tape Drive 2. SCSI Adapter or the SCSI controller built into the system board. 3. SCSI Cable (internal) SCSI Cable (external)
The tape is automatically ejected from the drive.	<ol style="list-style-type: none"> 1. Tape Cassette 2. Drive
† If this symbol is shown next to an error (above), go to "Related Service Information" on page 107.	

Symptom/Error	FRU/Action
SCSI ID on the rotary switch does not match the SCSI ID set in configuration. (Verify the drive switches inside the cover are set to zero)	<ol style="list-style-type: none"> 1. Rotary Switch Circuit Board 2. Circuit Board Cable 3. Tape Drive
Tape sticks/breaks in the drive. (Verify that the tapes used meet ANSI standard X3B5)	<ol style="list-style-type: none"> 1. Tape Cassette
0212XXXX	<ol style="list-style-type: none"> 1. SCSI Printer 2. Printer Cable
0213XXXX	<ol style="list-style-type: none"> 1. SCSI Processor
0214XXXX	<ol style="list-style-type: none"> 1. WORM Drive
0215XXXC 0215XXXD 0215XXXE 0215XX XU (If it is an external device, and the power-on LED is off, check external voltages) †	<ol style="list-style-type: none"> 1. CD-ROM Drive I CD-ROM Drive II Enhanced CD-ROM Drive II Any CD-ROM Drive 2. SCSI Cable 3. SCSI Adapter or the SCSI controller built into the system board.
0216XXXX	<ol style="list-style-type: none"> 1. Scanner
0217XXXX (If it is an external device, and the power-on LED is off, check external voltages) †	<ol style="list-style-type: none"> 1. Rewritable Optical Drive 2. SCSI Adapter or the SCSI controller built into the system board. 3. SCSI Cable
0218XXXX (Check for multi CD tray, or juke box)	<ol style="list-style-type: none"> 1. Changer
0219XXXX	<ol style="list-style-type: none"> 1. SCSI Communications Device
024201Y0, 024210Y0 (Be sure the wrap plug is not missing)	<ol style="list-style-type: none"> 1. ISDN/2 Adapter 2. ISDN/2 Wrap Plug 3. ISDN/2 Communications Cable
0243XXXX	<ol style="list-style-type: none"> 1. XGA-2 Display Adapter
002460XX	<ol style="list-style-type: none"> 1. 90MHz Processor Upgrade (without VRAM) 2. System Board
002461XX	<ol style="list-style-type: none"> 1. 90MHz Processor Upgrade (with 1MB VRAM)
†	If this symbol is shown next to an error (above), go to "Related Service Information" on page 107.

Symptom/Error	FRU/Action
0258XXXX Video might have failed. (Ensure that you are using diagnostic files XGAANI.DGS and XGAPNI.DGS dated 03/06/93 or later before you replace any FRUs. Earlier files cause erroneous errors.)	<ol style="list-style-type: none"> 1. XGA-2 Display Adapter 2. System Board
0259XXXX	<ol style="list-style-type: none"> 1. SVGA Adapter 2. System Board
0260XXXX	<ol style="list-style-type: none"> 1. System Board 2. Any SCSI Device
0270XXXX	<ol style="list-style-type: none"> 1. RAID Adapter Controller 2. System Board
0271XXXX	<ol style="list-style-type: none"> 1. RAID Hard Disk Drive 2. System Board
0273XXXX	<ol style="list-style-type: none"> 1. 1Mbps Micro Channel Infrared LAN Adapter
027501XX, 027503XX 027506XX, 027507XX	<ol style="list-style-type: none"> 1. ServerGuard Adapter 2. System Board
027502XX, 027504XX 027510XX, 027511XX 027533XX, 027534XX 027536XX, 027537XX	<ol style="list-style-type: none"> 1. ServerGuard Adapter
027509XX	<ol style="list-style-type: none"> 1. Remove redundant ServerGuard Adapters, run Auto Configuration program, then retest.
027512XX	<ol style="list-style-type: none"> 1. WMSELF.DGS diagnostics file missing. 2. WMSELF.DGS diagnostics file incorrect.
027535XX	<ol style="list-style-type: none"> 1. 3V Lithium Backup Battery 2. ServerGuard Adapter
027554XX	<ol style="list-style-type: none"> 1. Internal Temperature out of range 2. ServerGuard Adapter
027555XX, 027556XX	<ol style="list-style-type: none"> 1. ServerGuard Adapter 2. System Power Supply
027557XX	<ol style="list-style-type: none"> 1. 7.2V NiCad Main Battery Pack 2. ServerGuard Adapter
†	If this symbol is shown next to an error (above), go to "Related Service Information" on page 107.

Symptom/Error	FRU/Action
027558XX, 027559XX 027560XX, 027561XX	<ol style="list-style-type: none"> 1. PCMCIA Type II Modem 2. ServerGuard Adapter
027562XX	<ol style="list-style-type: none"> 1. External Power Control Box not connected 2. External Power Control Box 3. ServerGuard Adapter
027563XX, 027564XX	<ol style="list-style-type: none"> 1. External Power Control Box 2. ServerGuard Adapter
0275XXXX	<ol style="list-style-type: none"> 1. Update Diagnostic Software
0279XXXX	<ol style="list-style-type: none"> 1. Fast/Wide Streaming RAID Adapter/A (FRU No. 06H3059) 2. System Board 3. Signal Pass Through Card (if installed)
1998009X	<ol style="list-style-type: none"> 1. Restore System Partition
1999XXXX (This is usually not a hardware failure. Go to "IML and IPL Errors" on page 55 before replacing FRUs. Specific 1999XXXX error codes are listed after "IML and IPL Errors")	<ol style="list-style-type: none"> 1. Default Hard Disk Drive 2. Processor Board (90/95) 3. SCSI Adapter 4. SCSI Cable
†	If this symbol is shown next to an error (above), go to "Related Service Information" on page 107.

IML and IPL Errors

You are here because the system detects an Initial Machine Load (IML) problem or an Initial Program Load (IPL) problem. You can correct most of these errors without replacing any FRUs. IML/IPL problems are associated with the following:

- An 1999XXXX error is displayed.
- The computer powered-on without a POST error, but the operating system does not work.
- The system starts up in BASIC.

IML and IPL errors can be caused by any of the following conditions:

- Invalid selectable drive startup sequence (the default drive is not in the startup sequence)
- Operating system not found
- IML code not found

Related hardware failure (SCSI adapter, hard disk, SCSI cable)
 Unrelated hardware failure (misleading error code due to another problem on the SCSI Bus).

Before replacing any FRUs, check the following.

Checking Startup Sequence and Hard Disk Drive

1. Start the computer from the Reference Diskette and select **Set Features** from the Main Menu.
2. Select **Set Startup Sequence** and see if the *default* hard disk (usually drive 6) is in the startup sequence. If you receive an error message, follow the instructions on the screen, then return here.
3. If the default drive is in the startup sequence, exit from the screen and the Main Menu, then go to step 5. If the default drive is *not* in the startup sequence, follow the instructions on the screen, then continue with step 4.
4. Remove the Reference Diskette, power-off the computer, then power-on the computer. If the "F1" (Insert Diskette) icon appears on the screen, this means no operating system was found. Go to step 5. If the "Not OK" icon appears on the screen, this means that the system cannot access the System Partition. Try updating the system programs. If you need assistance, see "Updating the System Programs" on page 426.
5. Either install an operating system on a device that is in the startup sequence, or change the startup sequence to include a device that has an operating system, then power-on the computer, check for the normal power-up sequence and then run the advanced diagnostic tests. If the problem still exists, suspect the SCSI controller, then the hard disk drive.

Note: If you are not able to correct the problem using the IML and IPL Errors section, go to "Undetermined Problems" on page 183.

Symptom/Error	FRU/Action
I999001X, I999002X I999003X, I999004X (The actions for these errors are valid only when running the system from the hard disk)	1. Restore the System Partition. If you need assistance, see "Restoring the System Partition" on page 428.

Symptom/Error	FRU/Action
<p> I9990053, I9990054 I9990056, I9990057 I9990059, I9990063 I9990067, I9990069 (The actions for these errors are valid only when running the system from the System Diskettes) </p>	<ol style="list-style-type: none"> Restart the computer from the Reference Diskette. If the same error code appears, try new System Diskettes.
<p>I999006X</p>	<ol style="list-style-type: none"> Power-off the computer. Insert the Reference Diskette, toggle the override jumper, then power-on the computer. Then, restore the System Partition. If you need assistance, see "Restoring the System Partition" on page 428.
<p> I999007X, I999009X (The actions for these errors are valid only when running the system from the hard disk) </p>	<ol style="list-style-type: none"> Restore the System Partition. If you need assistance, see "Restoring the System Partition" on page 428
<p> I99900X1, I99900X2 I99900X3, I99900X4 I99900X6, I99900X7 I99900X9 (The actions for these errors are valid only when running the system from the System Diskettes) </p>	<ol style="list-style-type: none"> Restart the computer from the Reference Diskette. If the same error code appears, try new System Diskettes.
<p> I99900X5 (Reference Diskette recovery prevented) </p>	<ol style="list-style-type: none"> Power-off the computer, toggle the power-on password override jumper, then power-on the computer.
<p> I9990301 (Boot routine unable to read boot record. This is probably a hardware failure) </p>	<ol style="list-style-type: none"> Cable failure Wrong Termination SCSI Adapter/Controller Hard Disk
<p> I9990302 (No operating system found on the default SCSI hard disk) </p>	<ol style="list-style-type: none"> Install an operating system. Check for a valid selectable startup sequence.
<p> I9990303 The IML code did not load from the System Partition. </p>	<ol style="list-style-type: none"> Restore the System Partition. If you need assistance, see "Restoring the System Partition" on page 428.

Symptom/Error	FRU/Action
<p>ⓘ9990304 (No startable device found. This error is on ASCII consoles only)</p>	<ol style="list-style-type: none"> 1. No operating system installed. 2. Selectable startup sequence does not contain the default drive.
<p>ⓘ9990305 (No startable device found)</p>	<ol style="list-style-type: none"> 1. No operating system installed. 2. Selectable startup sequence does not contain the default drive.
<p>ⓘ9990306 (Invalid startup. Trying to start from a CD ROM drive)</p>	<ol style="list-style-type: none"> 1. Restart the computer from a startable diskette or hard disk drive.
<p>ⓘ9990401 (Unauthorized access. Type or erase the power-on password before replacing FRUs)</p>	<ol style="list-style-type: none"> 1. System Board or Processor Board Note: Whichever contains the system ROM
<p>ⓘ9990402, ⓘ9990403</p>	<ol style="list-style-type: none"> 1. System Board or Processor Board Note: Whichever contains the system ROM
<p>ⓘ9990600, ⓘ9990607 ⓘ9990609 (Recovery prevented)</p>	<ol style="list-style-type: none"> 1. Power-off the computer. Insert the Reference Diskette, toggle the override jumper, then power-on the computer. Then, restore the System Partition. If you need assistance, see "Restoring the System Partition" on page 428.

General Checkout (QAPLus/PRO)

This general checkout procedure is for computers that are supported by the QAPLus/PRO** Diagnostics test.

Diagnostic error messages appear when a test program finds a problem with a hardware option. For the test programs to properly determine if a test *Passed*, *Failed*, or *Aborted*, the test programs check the error-return code at test completion. (See "Return Codes" on page 388.)

For application program or operating system error messages, refer to the information supplied with that software package.

Notes

1. If multiple error codes are displayed, diagnose the first error code displayed.
2. If the computer hangs with a POST error, go to "Symptom-to-FRU Index (QAPLus/PRO)" on page 61.
3. If the computer hangs and no error is displayed, see "Undetermined Problems" on page 183.
4. If a device cannot be selected from the Module Test menu, that device may be defective.

001

- Power-off the computer and all external devices.
- Check all cables and power cords.
- Set all display controls to the middle position.
- Insert the QAPLus/PRO Diagnostics diskette into drive A.
- Power-on all external devices.
- Power-on the computer.
- Check for the following responses:
 1. One beep.
 2. Readable instructions or the Main Menu.

DID YOU RECEIVE THE CORRECT RESPONSES?

Yes No

002

Find the failure symptom in "Symptom-to-FRU Index (QAPLus/PRO)" on page 61.

003

Run the Advanced Diagnostics Test. If necessary, refer to "QAPLus/PRO Diagnostics" on page 386.

If you receive an error, go to "Symptom-to-FRU Index (QAPLus/PRO)" on page 61.

** QAPLus/PRO is a trademark of DiagSoft, Inc.

PC Server (8640) Setup Utility

To use the PC Server (8640) Setup utility, do the following.

1. Power-on the computer.
2. During the POST memory test, press and then release the spacebar; then press and release the **Ctrl+Alt+S** keys simultaneously. Or, in a DOS full screen, press then release the **Ctrl+Alt+S** keys simultaneously (this key combination will not work in an OS/2 DOS box.)
3. The "Standard System Parameters" screen will appear.
4. Follow the instructions on the screen to view or change the configuration.
5. Press **Esc** from any screen in the setup utility. The "Exiting Setup" pop-up screen will appear.
6. Press **F4** to save the configuration information and restart the server.

Important

When configuring a PC Server (8640), you must correctly exit the Setup utility to save the configuration information.

If a configuration error occurs during POST, a configuration error message appears before the operating system loads. (Press F1 to bypass the error.)

Do not start the Setup Utility while using the EISA configuration program (diskette).

Symptom-to-FRU Index (QAPLus/PRO)

Always start with "General Checkout (QAPLus/PRO)" on page 59.

The Symptom-to-FRU Index lists symptoms, errors, and the possible causes. The most likely cause is listed first. Use this index to help you decide which FRUs to have available when servicing the computer.

In the following error codes, X can be any number or letter.

Note

For IBM devices not supported by the QAPLus/PRO diagnostics code, refer to the manual for that device.

For information on:	Go to:
Additional service help. (For example, voltage checks, OS/2 Trap errors, or processor board errors)	"Related Service Information" on page 107
PC Server (8640) Setup Utility information	"PC Server (8640) Setup Utility" on page 60
Possible software and hardware mismatch problems. (Not repairable by replacing FRUs).	"Software/Hardware Mismatch Problems" on page 181
Memory Address Conflicts	"Resolving Memory-Address Conflicts" on page 408
Replacing the system board does not correct the problem, and a removable processor is installed.	"Processor Board Installation (90, 95)" on page 135

No Beep Symptoms

No Beep/Symptom	FRU/Action
No beep, fan runs, and 000215XX is displayed. (Check memory)	<ol style="list-style-type: none"> 1. System Board Memory 2. Processor 3. System Board
No beep, fan runs, and 000258XX is displayed. (Check memory)	<ol style="list-style-type: none"> 1. System Board
No beep and the computer is otherwise functional.	<ol style="list-style-type: none"> 1. Speaker Assembly 2. Processor 3. System Board
No beep and the computer is not functional (See "Undetermined Problems" on page 183.)	<ol style="list-style-type: none"> 1. System Board 2. Power Supply
No beep, fan runs, power-on LED lights, memory may or may not count, and blinking cursor continuously loops.	<ol style="list-style-type: none"> 1. Processor 2. System Board
No beep, power-on indicator does not come on, and fan does not run.	<ol style="list-style-type: none"> 1. Switch Assembly 2. Power Supply 3. Processor 4. System Board 5. Any Device or Adapter
No beep, fan runs, power-on indicator is on, and computer hangs during POST. (See "Undetermined Problems" on page 183)	<ol style="list-style-type: none"> 1. System Board 2. Processor 3. Power Supply

Beep Symptoms

Beeps symptoms are short tones or a series of short tones separated by pauses (intervals without sound). (X can be any number.)

Examples:

Beeps	Description
4	Four continuous beeps
1-2-X	One beep A pause (or break) Two beeps A pause (or break) Any number of beeps

Beep/Symptom	FRU/Action
4	1. Video Adapter 2. System Board
1-1-3 CMOS read/write error	1. Run Setup 2. System Board
1-1-4 ROM BIOS check error	1. System Board
1-2-X DMA error	1. System Board
1-3-1 RAM refresh verification error	1. System Board
1-3-X (not listed above) The first 64KB RAM module failed.	1. Memory Module 2. System Board
1-4-X An error was detected in the first 64KB of RAM.	1. Memory Module 2. System Board
2-1-X The first 64KB of RAM failed.	1. Memory Module 2. System Board
2-2-X The first 64KB of RAM failed.	1. Memory Module 2. System Board
2-3-X The first 64KB of RAM failed.	1. Memory Module 2. System Board
2-4-X The first 64KB of RAM failed.	1. Memory Module 2. System Board
3-1-X The DMA register failed.	1. System Board
3-2-4 The keyboard controller failed.	1. System Board 2. Keyboard

Beep/Symptom	FRU/Action
3-3-4 Screen initialization failed.	<ol style="list-style-type: none"> 1. Video Adapter 2. System Board 3. Display
3-4-1 The screen retrace test detected an error.	<ol style="list-style-type: none"> 1. Video Adapter 2. System Board 3. Display
3-4-2 POST is searching for video ROM.	<ol style="list-style-type: none"> 1. Video Adapter 2. System Board

Error Codes

Error Code/Symptom	FRU/Action
0000 SCSI Adapter not enabled.	<ol style="list-style-type: none"> 1. Be sure the adapter Device and Bus Master fields are enabled in the PCI configuration program. Refer to the documentation that was shipped with the computer.
002X	<ol style="list-style-type: none"> 1. SCSI Adapter
008X Check for proper installation of SCSI terminators.	<ol style="list-style-type: none"> 1. Check SCSI terminators for proper installation 2. SCSI Cable 3. SCSI Terminator 4. SCSI Device 5. SCSI Adapter
0115 Protected mode cannot be enabled.	<ol style="list-style-type: none"> 1. System Board
0164 POST detected a base memory or expansion memory size mismatch.	<ol style="list-style-type: none"> 1. Run Setup and ensure the memory size is correct 2. Run the Expanded Memory Diagnostic tests.
0601 Diskette configuration error	<ol style="list-style-type: none"> 1. Set Configuration
0610 Cannot find diskette controller for drive A.	<ol style="list-style-type: none"> 1. Diskette Drive 2. Diskette Drive Cable 3. Diskette Drive Adapter, if installed 4. System Board
0612 Cannot find diskette controller for drive B.	<ol style="list-style-type: none"> 1. Diskette Drive 2. Diskette Drive Cable 3. Diskette Drive Adapter, if installed 4. System Board
0616 Diskette drive reset failed.	<ol style="list-style-type: none"> 1. Diskette Drive Adapter

Error Code/Symptom	FRU/Action
0632 Diskette drive 0 seek failure	1. Diskette Drive A
0642 Diskette drive 1 seek failure	1. Diskette Drive B
0653 Diskette not formatted or defective	1. Format diskette 2. Diskette
0655 Diskette drive controller failed.	1. Diskette Drive 2. Diskette Drive Cable 3. Diskette Drive Adapter, if installed 4. System Board
107X Check for proper installation of SCSI terminators.	1. Check SCSI terminators for proper installation 2. SCSI Cable 3. SCSI Terminator 4. SCSI Device 5. SCSI Adapter
1701 Hard disk drive failed. Press F1 to restart the system.	1. Hard Disk Drive
1702 Hard disk drive controller error.	1. Hard Disk Drive Adapter, if installed 2. System Board
1704 Hard disk drive configuration error, controller failed.	1. Hard Disk Drive Adapter, if installed 2. System Board
1715 The Hard Disk Drive Configuration information is not correct.	1. Run Setup and enter the correct hard disk drive information
1726 Hard disk drive read error Press F1 to restart the system.	1. Hard Disk Drive
182X	1. SCSI Adapter
190X Ensure that each SCSI device is properly installed and powered-on.	1. SCSI Cable 2. SCSI Terminator 3. SCSI Device 4. SCSI Adapter
1XXX (not listed above)	1. SCSI Adapter
221X Ensure that each SCSI device is properly installed and powered-on.	1. SCSI Cable 2. SCSI Terminator 3. SCSI Device 4. SCSI Adapter
222X, 224X	1. SCSI Adapter
2401 The monochrome/color switch is not set correctly.	1. Correct the switch setting 2. Display Adapter

Error Code/Symptom	FRU/Action
3XXX Check for proper installation of SCSI terminators.	<ol style="list-style-type: none"> 1. Check SCSI terminators for proper installation 2. SCSI Cable 3. SCSI Terminator 4. SCSI Device 5. SCSI Adapter
4XXX Ensure that each SCSI device is properly installed and powered-on.	<ol style="list-style-type: none"> 1. SCSI Cable 2. SCSI Terminator 3. SCSI Device 4. SCSI Adapter
6XXX	1. SCSI Device
GP_COM The serial port test detected an error.	1. System Board
GP_FDU The diskette drive test detected an error.	<ol style="list-style-type: none"> 1. Diskette Drive 2. System Board 3. Diskette Drive Cable 4. Diskette
GP_HDU The hard disk drive test detected an error.	<ol style="list-style-type: none"> 1. Hard Disk Drive 2. Hard Disk Drive Cable 3. Hard Disk Drive Adapter (if installed) 4. System Board
GP_KBD The keyboard test detected an error.	<ol style="list-style-type: none"> 1. Keyboard 2. System Board
GP_MBD The system board test detected an error.	<ol style="list-style-type: none"> 1. System Board 2. Processor 3. Real-Time Clock Assembly
GP_MEM The memory test detected an error.	<ol style="list-style-type: none"> 1. Memory Module Kit 2. System Board
GP_PDV The mouse test failed.	<ol style="list-style-type: none"> 1. Mouse 2. System Board
GP_PRT The printer test detected an error.	<ol style="list-style-type: none"> 1. Printer 2. System Board 3. Printer Cable
GP_VID The video test detected an error.	<ol style="list-style-type: none"> 1. Video Adapter 2. System Board 3. Color Display
GRPCDR The CD-ROM test detected an error.	1. CD-ROM

Error Messages

Error Message/Symptom	FRU/Action
Arithmetic Functions Failed An error was detected during the CPU Test.	<ol style="list-style-type: none"> 1. Microprocessor 2. System Board

Error Message/Symptom	FRU/Action
Base Memory Test Failed An error was detected in base memory.	<ol style="list-style-type: none"> 1. Memory Module 2. System Board
Boot Sector Unreadable A boot sector read error was detected on the hard disk drive.	<ol style="list-style-type: none"> 1. Hard Disk Drive 2. Hard Disk Drive Cable 3. Hard Disk Drive Adapter (if installed) 4. System Board
Bus Noise Test Failed The RAM Test detected an error in the memory bus.	<ol style="list-style-type: none"> 1. Memory Module 2. System Board
Butterfly Cylinder Access Test Failed The Hard Disk Drive Test detected mismatch between the data read and the data stored on the drive.	<ol style="list-style-type: none"> 1. Hard Disk Drive 2. Hard Disk Drive Cable 3. Hard Disk Drive Adapter (if installed) 4. System Board
Clock Stopped The real-time clock has stopped working.	<ol style="list-style-type: none"> 1. Real-Time Clock Assembly 2. System Board
CMOS Clock Test Failed The Time and Date Settings for CMOS and DOS do not Match .	<ol style="list-style-type: none"> 1. Real-Time Clock Assembly 2. System Board
Controller Diagnostic Test Failed An error was detected while testing the Hard Disk Controller (Adapter).	<ol style="list-style-type: none"> 1. Hard Disk Drive Adapter (if installed) 2. Hard Disk Drive 3. System Board
Controller does not respond to commands; no logical drive installed.	<ol style="list-style-type: none"> 1. RAID Adapter 2. System Board
Cylinder 0 errors The test detected an error reading the first cylinder of the hard disk drive.	<ol style="list-style-type: none"> 1. Hard Disk Drive 2. Hard Disk Drive Adapter (if installed) 3. System Board
Device is Not Ready Ready the Device... or Press Any Key	<ol style="list-style-type: none"> 1. Ensure the device is powered-on 2. Replace failing device 3. Device Adapter (if installed) 4. System Board
Disk Error Encountered Opening Output File Press Any Key To Continue.	<ol style="list-style-type: none"> 1. Hard Disk Drive 2. Hard Disk Drive Adapter (if installed) 3. System Board
DMA #X Failed The Main Components Test detected an error while testing the DMA controller.	<ol style="list-style-type: none"> 1. System Board

Error Message/Symptom	FRU/Action
DMA Page Register Failed An error was detected while outputting all possible values to the DMA Page Register.	<ol style="list-style-type: none"> 1. System Board
Drive (x) Media (y) Mismatch The capacity listed for the drive in the File Allocation Table ID does not match the calculated capacity of the drive.	<ol style="list-style-type: none"> 1. Check diskette and diskette drive capacity. 2. Diskette Drive 3. System Board
Drive in channel X bay X does not respond. Installation stopped.	<ol style="list-style-type: none"> 1. Replace the drive in the bay indicated.
Error in video buffer. Bad bits The video memory test failed.	<ol style="list-style-type: none"> 1. Video Adapter 2. System Board 3. Display
Exception Interrupt In Protected Mode Diags Cannot Continue Server error, all system tests will stop. Remove one adapter at a time until the symptom goes away.	<ol style="list-style-type: none"> 1. Any Adapter 2. System Board 3. Processor
Extended Memory Test Failed An error was detected in Extended Memory.	<ol style="list-style-type: none"> 1. Memory Module 2. System Board
Floppy Drive Failed One or more diskette drives failed.	<ol style="list-style-type: none"> 1. Diskette Drive 2. System Board 3. Diskette Drive Cable
General Function Failed Remove one adapter at a time until the symptom goes away.	<ol style="list-style-type: none"> 1. Any Adapter 2. System Board 3. Processor
Hard Drives Failed One or more of the Hard Disk Drive tests detected an error.	<ol style="list-style-type: none"> 1. Hard Disk Drive 2. Hard Disk Drive Adapter (if installed) 3. System Board
Incorrect DOS version	<ol style="list-style-type: none"> 1. Ensure you are using DOS version 3.0 or higher.
INT Mask Register Failed The INT Mask Register tests detected an error.	<ol style="list-style-type: none"> 1. Microprocessor 2. System Board
Invalid Date The back-up clock and DOS dates do not match.	<ol style="list-style-type: none"> 1. Real-Time Clock Assembly 2. System Board

Error Message/Symptom	FRU/Action
Invalid Time The back-up clock and DOS time of day settings do not match.	<ol style="list-style-type: none"> 1. Real-Time Clock Assembly 2. System Board
Linear Cylinder Access Test Failed Hard disk drive error. The redundancy check of the sectors read does not match the information on the drive.	<ol style="list-style-type: none"> 1. Hard Disk Drive 2. Hard Disk Drive Cable 3. Hard Disk Drive Adapter (if installed) 4. System Board
Logic Function Failed The CPU Logic Test has detected an error.	<ol style="list-style-type: none"> 1. Microprocessor 2. System Board
Loopback Error An error occurred during the COM Port Test or Parallel Port Test. (A wrap plug must be installed to successfully complete these tests.)	<ol style="list-style-type: none"> 1. System Board 2. Wrap Plug
Main Components Failed A component failure was detected on the system board.	<ol style="list-style-type: none"> 1. System Board 2. Processor
Memory test cannot run at this location in memory Not enough free memory available to start the memory test.	<ol style="list-style-type: none"> 1. Memory Module 2. System Board
Missing QAPLus/PRO Files(s) One or more Diagnostic support files are missing.	<ol style="list-style-type: none"> 1. Diagnostic Diskette
NO LOOP-BACK PLUG. Skipping External loopback test No wrap plug installed.	<ol style="list-style-type: none"> 1. Install wrap plug on the serial port, rerun test. 2. System Board
Not ready Printer not on-line or not ready.	<ol style="list-style-type: none"> 1. Ready Printer 2. Printer 3. Printer Cable 4. System Board
No 'type-amatic' repeat (At least one repeat key must be tested during this test or an error will occur.) The Type-amatic test detected an error.	<ol style="list-style-type: none"> 1. Keyboard 2. System Board
Not used by any standard device The IRQ is not currently being used by a non-standard device.	<ol style="list-style-type: none"> 1. System Board

Error Message/Symptom	FRU/Action
Numeric Proc Failed The NPU TEST detected an error.	1. Microprocessor 2. System Board
Parallel Ports Failed Test Report Summary message.	1. System Board
Pass (N): ** Errors ** Drive (X) Failed The read/write test failed on the diskette drive.	1. Diskette Drive 2. System Board 3. Diskette Drive Cable
Pass (N) Drive Not Ready The diskette drive door is open or defective.	1. Ensure diskette drive is ready. 2. Diskette Drive 3. System Board 4. Diskette Drive Cable
Pass (N): Drive (X) Write Protected or Unformatted	1. Insert a non-write protected, formatted diskette into the diskette drive; the rerun the test 2. Diskette Drive 3. System Board 4. Diskette Drive Cable
Pass (N): Unknown Media Drive (X) Diskette Drive Test error. The File Allocation Table ID on the diskette is invalid.	1. Diskette 2. Diskette Drive 3. System Board 4. Diskette Drive Cable
Place Hi-density Media in Drive The capacity of the diskette installed in the diskette drive is less than the capacity of the drive.	1. Diskette 2. Diskette Drive 3. System Board 4. Diskette Drive Cable
Printer Failed Ensure the printer is powered-on and ready.	1. Printer 2. Printer Cable 3. System Board
Printer Fault Ensure the printer is powered-on and ready.	1. Printer 2. Printer Cable 3. System Board
Printer Not Selected Ensure the printer is powered-on and ready.	1. Printer 2. Printer Cable 3. System Board
Program or File Not Found Press Any Key The diagnostics cannot find the USER(N).COM file.	1. Diagnostic Diskette 2. Diskette Drive 3. System Board
Program Too Big To Fit In Memory Too many Terminate and Stay Resident programs in memory while loading diagnostics.	1. Reboot the system from the Diagnostic Diskette

Error Message/Symptom	FRU/Action
<p>QAPLUS/PRO Cannot Be Re-run Because Of Error In Relocating Program Diagnostics failed to relocate the Diagnostics Test programs so the memory space it resides in was not tested.</p>	<ol style="list-style-type: none"> 1. Diagnostic Diskette 2. Memory Module 3. System Board
<p>RAM Memory Error in Block n. Bad bits n An error was detected in RAM.</p>	<ol style="list-style-type: none"> 1. Memory Module 2. System Board
<p>RAM Test Failed Test Result Summary message, Memory Test failed.</p>	<ol style="list-style-type: none"> 1. Memory Module 2. System Board
<p>Read error on cylinder n Hard disk drive physical format error.</p>	<ol style="list-style-type: none"> 1. Hard Disk Drive 2. Hard Disk Drive Adapter (if installed) 3. System Board
<p>Read Errors Diskette drive read error.</p>	<ol style="list-style-type: none"> 1. Diskette 2. Diskette Drive 3. System Board 4. Diskette Drive Cable
<p>Receive Error Serial Port loopback test error.</p>	<ol style="list-style-type: none"> 1. Serial Port Cable 2. System Board
<p>Refresh Failure The Diagnostics Test detected an error while testing the DMA controller's RAM refresh cycle.</p>	<ol style="list-style-type: none"> 1. Memory Module 2. System Board
<p>RTC Interrupt Failure The Diagnostics Test cannot detect the Real-Time clock interrupt.</p>	<ol style="list-style-type: none"> 1. Real-Time Clock Assembly 2. System Board
<p>Serial Chip Error COM Port error, general.</p>	<ol style="list-style-type: none"> 1. Serial Port Cable 2. System Board
<p>Serial Compare Error COM Port error, information transmitted is not the same as information received.</p>	<ol style="list-style-type: none"> 1. Serial Port Cable 2. System Board
<p>Serial Time-out Error COM Port error, time interval is too long between transmitted and received data.</p>	<ol style="list-style-type: none"> 1. Serial Port Cable 2. System Board
<p>Serious Memory Error — Diags Cannot Continue Memory Test error.</p>	<ol style="list-style-type: none"> 1. Memory Module 2. System Board
<p>Sorry You Need A Mouse The mouse or mouse driver was not detected.</p>	<ol style="list-style-type: none"> 1. Mouse 2. System Board

Error Message/Symptom	FRU/Action
System Hangs See "Undetermined Problems" on page 183.	<ol style="list-style-type: none"> 1. Any device 2. Any adapter 3. System Board
Too Many Errors — Test Aborted Too many errors, the Diagnostics Test cannot continue.	<ol style="list-style-type: none"> 1. Microprocessor 2. System Board
Transmit Error Internal or external serial port loopback test failure.	<ol style="list-style-type: none"> 1. Serial Port Cable 2. System Board
Video Adapter Failed Test Result Summary, displayed if "Fail" was at the Quit/Fail/Pass menu of any video test.	<ol style="list-style-type: none"> 1. Video Adapter 2. System Board 3. Display
Write error on cylinder n Hard disk drive write error.	<ol style="list-style-type: none"> 1. Hard Disk Drive 2. Hard Disk Drive Adapter (if installed)
Write Errors Diskette drive write error.	<ol style="list-style-type: none"> 1. Diskette 2. Diskette Drive 3. System Board 4. Diskette Drive Cable
Write Protected or Unformatted The diskette is Write Protected or not formatted.	<ol style="list-style-type: none"> 1. Insert a non-write protected, formatted diskette into the diskette drive; then rerun the test 2. Diskette Drive 3. System Board 4. Diskette Drive Cable

Miscellaneous Error Messages

Message/Symptom	FRU/Action
The Address Exceeds The Size Of Your Memory An invalid memory address was entered. The Diagnostics Tests display this message during the Locate Bad Chips option under the interact menu if an invalid memory address was entered at the at the "Enter Memory Address Of Bad Chip" prompt.	<ol style="list-style-type: none"> 1. Enter correct address 2. Memory Module 3. System Board

Message/Symptom	FRU/Action
<p>That Number is Out Of Range An invalid bit number was entered. The Diagnostics Tests display this message during the Locate Bad Chips option under the interact menu if an invalid bit number was entered at the "Enter the Bad Bit" prompt.</p>	<ol style="list-style-type: none"> 1. Enter correct number 2. Memory Module 3. System Board
<p>You Cannot Delete the Motherboard The "Remove Board" option was selected. The Diagnostics Tests display this message during the Locate Bad Chips option under the interact menu if the "Remove Board" option was selected while the system board was displayed.</p>	<ol style="list-style-type: none"> 1. Make the correct selection 2. Memory Module 3. System Board 4. Processor

Network Service Procedures

The following section provides switch settings and testing procedures for the Token-Ring and Ethernet network adapters.

Note: For information about ISA PS/ValuePoint 10BASE-T/10BASE2 Ethernet Adapters, see "ISA PS/ValuePoint 10BASE-T/10BASE2 Ethernet Adapters" on page 90.

Data Rate Switch Settings

Switch 12 on the switch block indicates the mega bits per second rate (4 Mbps or 16 Mbps) at which the adapter transfers data to the network. Set the switches as shown to match the data rate of the LAN segment.

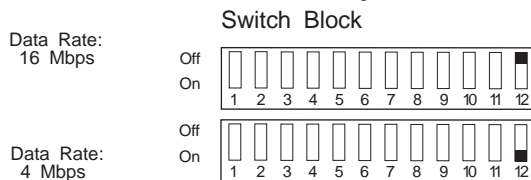

Note: These switch settings apply to AT bus adapters only. Micro Channel adapters do not have switches.

Testing the Token-Ring Adapter

To test the Token-Ring adapter:

1. Locate the Token-Ring diskette that matches the adapter in the computer you are servicing.

Note: Token-Ring Network Adapter/A has a plain green dot on the rear of the adapter. Token-Ring 16/4 Network Adapter/A has "16/4" printed on the dot.

2. Insert the diskette in the diskette drive, then power-on the computer. The Ring Diagnostic menu appears.

Note: If the computer is already on, type `A:F1DIAG` at the DOS command prompt then press **Enter** to load the Token-Ring Setup/Diagnostic program.

3. Select **Option 0** to test the primary Token-Ring adapter, then press **Enter**. The adapter address will be displayed for a few seconds before the diagnostics are run.

The following is a list of possible error conditions that can occur when the workstation is attempting to connect to the network:

Problem	Action
<p>AC—0040 0000 0000 Field appears</p>	<p>This field indicates that the adapter has detected an internal error. Restart the workstation.</p> <p>If the problem remains, replace the Token-Ring adapter. If the problem still remains, replace the system board.</p>
<p>AE—166 XX—0011 Field appears</p>	<p>This field indicates that the workstation contains two Token-Ring adapters. The primary adapter shown here (166) could not establish communication with the file server. The reason is indicated by the XX message and can be either BU or OP. (The BU and OP were described previously)</p> <p>Restart the workstation.</p> <p>If the problem remains, replace the Token-Ring adapter. If the problem still remains, replace the system board.</p>
<p>BU—XXXX Field appears</p>	<p>This field indicates errors that occur during startup.</p> <p>If a code other than appears and the field is highlighted, an error has occurred. The following is a list of possible error codes.</p> <p> 24— The shared RAM diagnostic failed. Ensure that the RAM address assigned for the Token-Ring adapter does not conflict with other devices installed in the workstation. (Refer to “Selecting Network Configuration Parameters” on page 87, if you need additional information about the configuration parameters.)</p> <p> All other error codes— Replace the Token-Ring adapter. If the problem remains, replace the system board.</p> <p>If the above items are correct, restart the workstation.</p> <p>If the problem remains, replace the Token-Ring adapter. If the problem still remains, replace the system board.</p>
<p>CE—0085 Field appears</p>	<p>This field indicates that a data rate configuration error was found during power-on self test.</p> <p>To correct this error, go to “Data Rate Switch Settings” on page 74 to match the data rate of the LAN segment. (Refer to “Selecting Network Configuration Parameters” on page 87, if you need additional information about the configuration parameters.)</p> <p>If the problem remains, replace the Token-Ring adapter.</p> <p>If the problem still remains, replace the system board.</p>

Problem	Action
<p>ET—00:00:02 Field stops incrementing</p>	<p>If the elapsed time indicator stops incrementing, check that:</p> <ol style="list-style-type: none"> 1. All cables and cords are properly attached to the workstation. 2. The file server is operational. 3. The correct data rate is set for the Token-Ring adapter. <p>If the above items are correct, restart the workstation. If the problem remains, replace the Token-Ring adapter. If the problem still remains, replace the system board.</p>
<p>OP—0000 XX Field appears flashing or is highlighted</p>	<p>If a code other than appears:</p> <p>If the code is 11 or 2D and the field is flashing:</p> <ol style="list-style-type: none"> 1. Ensure that all cables and cords are properly attached to the workstation and network access point. 2. Ensure that the file server is available and fully operational. <p>If the code is 2E and the field is highlighted, the adapter is configured for a different data rate than the LAN segment.</p> <p>To correct this error, you must manually change the data rate for the network adapter. Refer to "Data Rate Switch Settings" on page 74 to match the data rate of the LAN segment.</p> <p>If the above items are correct and the problem remains, replace the Token-Ring adapter. If the problem still remains, replace the system board.</p>
<p>PC—4020 Field appears</p>	<p>This field indicates that the adapter is not functioning properly with the workstation. In most cases, the screen will freeze and this field will be highlighted because the adapter cannot continue. Restart the workstation.</p> <p>If the problem remains, replace the Token-Ring adapter. If the problem still remains, replace the system board.</p>

Problem	Action
<p>RQ—XXXX Field appears and XXXX is a value greater than 10</p>	<p>A number greater than 10 indicates that the file server is not present or is overloaded.</p> <ol style="list-style-type: none"> 1. Ensure that the file server is available and fully operational. 2. Ensure that the address for the Token-Ring adapter installed in the workstation has been properly added to the network software. <p>If the above items are correct and the problem remains, replace the Token-Ring adapter. If the problem still remains, replace the system board.</p>
<p>RS—XXXX Field appears</p>	<p>If this field appears in reverse video with a code other than , a ring error was detected. The following is a list of possible error codes where x can be any number:</p> <p>2 — The adapter has detected a soft error condition. Restart the workstation.</p> <p>4XX or 8XX— Replace the Token-Ring adapter. If the problem remains, replace the system board.</p> <p>X1XX— The Token-Ring adapter has been removed from the ring. Ensure that the correct adapter address was added to the network software. If the above item is correct and the problem remains, replace the Token-Ring adapter. If the problem still remains, replace the system board.</p> <p>8 — One of the error log counters has incremented past 256. Restart the workstation.</p> <p>4 or 6 — If the workstation is the only computer connected to the LAN, restart the workstation. If other workstations are connected to the LAN, run the Diagnostic Diskette (see "Testing the Token-Ring Adapter" on page 74) and select "Ring Diagnostics" from the Main Menu.</p> <p>If the problem remains, replace the Token-Ring adapter. If the problem still remains, replace the system board.</p> <p>All other error codes— run the Diagnostic Diskette (see "Testing the Token-Ring Adapter" on page 74) and select "Ring Diagnostics" from the Main Menu.</p> <p>If the problem remains, replace the Token-Ring adapter. If the problem still remains, replace the system board.</p>

Problem	Action
<p>SF—XXXX Field appears and XXXX is a value greater than 10</p>	<p>A number greater than 10 indicates that the file server has been found, but is not responding.</p> <ol style="list-style-type: none"> 1. Ensure that the file server is available and fully operational. 2. Ensure that the address for the Token-Ring adapter installed in the workstation has been properly added to the network software. <p>If the above items are correct and the problem remains, replace the Token-Ring adapter. If the problem still remains, replace the system board.</p>

Token-Ring POST Errors

The following is a list of the Token-Ring adapter error messages that might appear in the top-left corner of the screen during POST. In this table, "X" represents a 6 (primary adapter) or a 7 (alternate adapter).

Message	Action
16X80	Invalid testing mode requested. Restart the workstation. If the problem remains, replace the Token-Ring adapter.
16X81	The primary adapter was not found at the specified base I/O address. Ensure that a unique base I/O address was assigned to the adapter. If a unique base I/O address was assigned to the adapter, restart the workstation. If the problem remains, replace the Token-Ring adapter.
16X82	The alternate adapter was not found at the specified base I/O address. Ensure that a unique base I/O address was assigned to the adapter. If a unique base I/O address was assigned to the adapter, restart the workstation. If the problem remains, replace the Token-Ring adapter.
16X85	The adapter was not found at the specified base I/O address. Ensure that a unique base I/O address was assigned to the adapter. If a unique base I/O address was assigned to the adapter, restart the workstation. If the problem remains, replace the Token-Ring adapter.
16X90	Adapter Card Test failure. Restart the workstation. If the problem remains, replace the Token-Ring adapter.
16X91	Open Phase Test failure. Restart the workstation. If the problem remains, replace the Token-Ring adapter.
16X92	Computer problem. Run Advanced Diagnostics.

Message	Action
16X93	<p>Transmit/Receive Test failure.</p> <p>The data received is not the same as the data sent.</p> <p>Check to see that:</p> <ol style="list-style-type: none"> 1. The network is terminated correctly. 2. The network is connected correctly. <p>If the above items are correct, restart the workstation.</p> <p>If the problem remains, replace the Token-Ring adapter.</p>
16X99	<p>General error.</p> <p>Restart the workstation.</p> <p>If the problem remains, replace the Token-Ring adapter.</p>

Testing the Ethernet Adapter

To test the Ethernet adapter:

1. Insert the feature diskette in the diskette drive, then power-on the computer. The Ethernet Setup/Diagnostic program will automatically load.

Note: If the computer is already on, type `A:F1DIAG` at the DOS command prompt then press **Enter** to load the Ethernet Setup/Diagnostic program.

2. Select **Option 2. Test the Adapter** from the Main Menu, then press **Enter**. The adapter address will be displayed for a few seconds before the diagnostics are run.

The following is a list of possible error conditions that can occur when the workstation is attempting to connect to the network:

Problem	Action
AC—0000 Field appears	This field indicates that the adapter has detected an internal error. If the code is 1, a soft error has occurred. Restart the workstation. If the code is 2, an unrecognized interrupt was found. Ensure that a unique interrupt level was assigned to the network adapter (refer to "Network Configuration Errors" on page 89 for additional information). If a unique interrupt level was assigned, restart the workstation. If the problem remains, replace the Ethernet adapter.
CE—0085 Field appears	If a code other than 1 appears, a configuration error was found during POST. Run the Automatic Configuration program on the Starter Diskette image. Then ensure that a non-conflicting ROM address, RAM address, and interrupt level were assigned to the network adapter (refer to "Network Configuration Errors" on page 89 for additional information). If the problem remains, replace the Ethernet adapter.

Problem	Action
<p>ES—XXXX Field appears and remains on the screen</p>	<p>This field indicates the network status error messages. The following is a list of possible error messages:</p> <ul style="list-style-type: none"> 1: The network adapter stopped the transmission because of excessive collisions. 2: The network interface controller cannot gain access to the bus. 4: The network adapter transmitted data without deferring. 8: The data transmitted from the network adapter collided, at least once, with another workstation's transmission. <ul style="list-style-type: none"> 1 : The carrier sense was lost during transmission. 2 : The multistation access unit (MAU) failed to transmit a collision signal after transmitting a packet. 4 : An "out of window" (51.2-microsecond) collision occurred. 1 : The receive buffer is full. 2 : The frame size is too large to receive. 4 : Packets were received with cyclic redundancy check (CRC) errors. 8 : The incoming packet did not end on a byte boundary; therefore, the CRC did not match the last byte. 1 : First-in, first-out (FIFO) is not serviced and is causing an overflow during reception. 2 : A packet was missed because the receive buffers were full. <p>These hexadecimal error messages all reflect soft-error conditions. Under normal circumstances, no action is required. When several of these errors occur simultaneously, they are ORed. For example, if errors 1, 2, 4, and 8 occur simultaneously, an error code of F appears.</p> <p>If the error code appears and remains on the screen:</p> <ol style="list-style-type: none"> 1. Restart the workstation. 2. Ensure that you have not exceeded the number of devices that the network can support. <p>If the above items are correct, restart the workstation.</p> <p>If the problem remains, replace the Ethernet adapter.</p>

Problem	Action
<p>ET—00:00:02 Field stops incrementing</p>	<p>If the elapsed time indicator stops incrementing, check that:</p> <ol style="list-style-type: none"> 1. All cables and cords are properly attached to the workstation. 2. The address for the network adapter was properly added to the network software. 3. The adapter configuration (BNC/UTP) is set properly. 4. The server is operational. <p>If the above items are correct, restart the workstation. If the problem remains, replace the Ethernet adapter.</p>
<p>OP—XXXX Field appears</p>	<p>If a code other than appears, an error has occurred during startup. The following is a list of possible error messages:</p> <ol style="list-style-type: none"> 1: The network adapter was not found. Check to see that: <ol style="list-style-type: none"> 1. The adapter is installed in the workstation. 2. All cables and cords are connected correctly to the workstation and network-access point. 3. The file server is available and fully operational. <p>If the above items are correct, restart the workstation. If the problem remains, replace the Ethernet adapter.</p> 3: The shared RAM diagnostic tests failed. Ensure that the RAM address assigned for the network adapter does not conflict with other devices installed in the workstation. Refer to "Network Configuration Errors" on page 89 for additional information and instructions. 4: The interrupt-request line for the network adapter was not found. Ensure that the interrupt level assigned to the network adapter does not conflict with other devices installed in the workstation. Refer to "Network Configuration Errors" on page 89 for additional information and instructions. 5 or 6: The adapter appears defective. Run the test programs on the Starter Diskette image. <p>If the problem remains, replace the Ethernet adapter.</p>

Problem	Action
<p>RQ—XXXX Field appears and XXXX is a value greater than 000A</p>	<p>If a number greater than 000A appears, the file server is not present or is overloaded. Check that:</p> <ol style="list-style-type: none"> 1. The server is available and fully operational. 2. The address for the network adapter was properly added to the network software. 3. The adapter configuration (BNC/UTP) is set properly. <p>If the above items are correct and the problem remains, replace the Ethernet adapter.</p>
<p>SF—XXXX Field appears and XXXX is a value greater than 000A</p>	<p>If a number greater than 000A appears, the server was found, but is not responding. Check that:</p> <ol style="list-style-type: none"> 1. The server is available and fully operational. 2. The address for the network adapter was properly added to the network software. <p>If the above items are correct and the problem remains, replace the Ethernet adapter.</p>

Ethernet POST Errors

The following is a table of Ethernet adapter error messages that might appear in the top-left corner of the screen during POST.

Number	Action
06402	The adapter was not found. Check to see that the adapter is installed correctly in the workstation. If so, restart the workstation. If the problem remains, replace the Ethernet adapter.
06405	The adapter was not found at the specified base I/O address. Ensure that a unique base I/O address was assigned to the adapter. Refer to "Network Configuration Errors" on page 89 for additional information and instructions. If a unique base I/O address was assigned to the adapter, restart the workstation. If the problem remains, replace the Ethernet adapter.
06406 06416 – or – 06417	ROM Test failure. 06406 LAN address ROM does not produce a valid checksum. 06416 Adapter erasable-programmable read-only memory (EPROM) signature is not valid. 06417 Adapter EPROM checksum is not valid. Check to see that a unique base ROM address was assigned to the network adapter. Refer to "Network Configuration Errors" on page 89 for additional information and instructions. If a unique ROM address was assigned to the adapter, restart the workstation. If the problem remains, replace the Ethernet adapter.
06411	RAM Test failure. Ensure that a unique RAM address was assigned to the adapter. Refer to "Network Configuration Errors" on page 89 for additional information and instructions. If a unique RAM address was assigned to the adapter, restart the workstation. If the problem remains, replace the Ethernet adapter.
06412	Adapter Test failure. Restart the workstation. If the problem remains, replace the Ethernet adapter.

Number	Action
06418 06419 06420 06421 06422 06423 – or – 06424	<p>Transmit/Receive Test failure.</p> <p>06418 Loopback first-in, first-out (FIFO) error.</p> <p>06419 Loopback packet error.</p> <p>06420 A cyclic redundancy check (CRC) character was expected but not generated.</p> <p>06421 Loopback error.</p> <p>06422 A good CRC was manually appended to the loopback packet, but the network interface controller (NIC) logged a CRC error.</p> <p>06423 A bad CRC was manually appended to the loopback packet, but the NIC logged a CRC error.</p> <p>06424 A NIC accepted a packet whose address did not match that of the NIC.</p> <p>The data received is not the same as data sent. Check to see that:</p> <ol style="list-style-type: none"> 1. The network is terminated correctly. 2. The network is connected correctly. <p>If the above items are correct, restart the workstation. If the problem remains, replace the Ethernet adapter.</p>
06425	<p>Interrupt not serviced. Ensure that a unique interrupt level was assigned to the adapter. Refer to "Network Configuration Errors" on page 89 for additional information and instructions. If a unique interrupt level was assigned to the adapter, restart the workstation. If the problem remains, replace the Ethernet adapter.</p>

Selecting Network Configuration Parameters

The following configuration parameters are available for the network adapter.

Interrupt Levels: The network adapter can use interrupt levels 3, 4, 10, or 14. Many application programs used with the network adapter require the adapter to be set at a specific interrupt level.

When choosing the interrupt level for the network adapter, you must consider the interrupt levels allowed and required for each option installed in the workstation and by all programs that will be used by the workstation. Unless the options and programs support interrupt sharing, no two options in the same workstation can use the same interrupt level.

Adapter I/O Range: The network adapter can use any of the following locations for the hexadecimal base I/O address.

Table 1. Hexadecimal Base I/O Address Locations

00800-0081F	02800-0281F	04800-0481F
01800-0181F	03800-0381F	05800-0581F

Read-Only Memory (ROM) Address Range: The network adapter can use any of the following locations for the hexadecimal base ROM address.

Table 2. Hexadecimal Base ROM Address Locations

C8000-C9FFF	D0000-D1FFF	D8000-D9FFF
CA000-CBFFF	D2000-D3FFF	DA000-DBFFF
CC000-CDFFF	D4000-D5FFF	DC000-DDFFF
CE000-CFFFF	D6000-D7FFF	DE000-DFFFF

When other options, such as a memory-expansion adapter, require addresses for sections of the workstation memory, the ROM address for each option must be set so that no two options in the same workstation use the same ROM address.

Shared Random-Access Memory (RAM) Range:

The network adapter can have either 8KB or 16KB of RAM. Any of the following locations can be used for the hexadecimal base RAM address.

C0000-C1FFF	CC000-CDFFF	D8000-D9FFF
C2000-C3FFF	CE000-CFFFF	DA000-DBFFF
C4000-C5FFF	D0000-D1FFF	DC000-DDFFF
C6000-C7FFF	D2000-D3FFF	DE000-DEFFF
C8000-C9FFF	D4000-D5FFF	
CA000-CBFFF	D6000-D7FFF	

C0000-C3FFF	CA000-CDFFF	D4000-D7FFF
C2000-C5FFF	CC000-CFFFF	D6000-D9FFF
C4000-C7FFF	CE000-D1FFF	D8000-DBFFF
C6000-C9FFF	D0000-D3FFF	DA000-DDFFF
C8000-CBFFF	D2000-D5FFF	DC000-DEFFF

Remote Program Load Option: This parameter controls the remote IPL capability of the workstation. It *must* be set to "Enabled" for the workstation to receive remote IPL images. *Do not* set this parameter to "Disabled" unless a hard disk drive that contains an operating system and a network program is installed in the workstation, or you have installed an additional network adapter in the workstation.

Network Configuration Errors

If an error occurs during testing of the network adapter, record the error message or number, then check to see that the network adapter is configured so that no conflicts exist. If a conflict exists, an asterisk (*) appears next to the parameter on the Change Configuration panel.

Complete the following steps to check for conflicts:

1. Make the Starter Diskette or Reference Diskette image available to the workstation.
2. Power-on the workstation and display.
3. Wait for the IBM logo screen to appear; then press Enter.
4. Select **Set configuration** from the Main Menu of the Starter Diskette or Reference Diskette image.
5. Select **Change configuration** from the next menu.
6. Page down to the configuration information for the network adapter.
Note: Conflicts with interrupt levels might not be indicated. Ensure that each device has a unique interrupt level assigned.
7. Change the parameters if a conflict exists. (Refer to "Selecting Network Configuration Parameters" on page 87, if you need additional information about the configuration parameters.)
8. If you corrected a conflict, run the test programs on the Starter Diskette or Reference Diskette image again.

If the problem remains, replace the network adapter. If the problem still remains, replace the system board and reinstall the original network adapter.

ISA PS/ValuePoint 10BASE-T/10BASE2 Ethernet Adapters

The IBM PS/ValuePoint ISA 10BASE-T/10BASE2 Ethernet Adapters enable you to connect an Industry Standard Architecture (ISA) AT bus computer family workstation to an Ethernet local area network (LAN). The 10BASE-T Ethernet Adapter has an unshielded twisted pair connector and the 10BASE2 Ethernet Adapter has a bayonet connector (BNC). Both adapters have a set of light emitting diode (LED) indicator lights that represent the following conditions:

POWER/TX (green) blinks during data transmission.
LINK/RX (green) blinks when data is being received, and indicates the "link integrity signal" from the twisted-pair hub is present.

COLLISION (yellow) indicates multiple concurrent transmissions on the network.

JABBER (yellow) indicates data transmission is interrupted to inhibit an abnormally long output data stream (10BASE2 Ethernet Adapter only).

ISA PS/ValuePoint Ethernet Adapter Features Diskette

The IBM PS/ValuePoint ISA Ethernet Adapter Features Diskette contains device drivers and a setup/diagnostic program for the Ethernet Adapter.

ISA PS/ValuePoint Ethernet Adapter Configuration Options

Ensure that the adapter configuration **does not** conflict with the system configuration or other adapters.

The I/O address, the IRQ interrupt levels, and the ROM address can be changed. For additional information, see "I/O Address," "IRQ Interrupt Levels" on page 91, and "ROM Address" on page 91.

I/O Address: The PS/ValuePoint Ethernet Adapter can use any of the following locations for the hexadecimal base I/O address. The default is 300. The I/O address must be set at 300 or 320 if the Novell Netware Device Driver is used.

800	1800	2800
3800	300	320

IRQ Interrupt Levels: The PS/ValuePoint Ethernet Adapter can use interrupt levels 3, 4, 5, 9, or 11. The default is 3. The IRQ interrupt level must be set at 3 if the Novell Netware NE2000 Device Driver is used. If the adapters and programs **do not** support interrupt sharing, the adapters cannot use the same interrupt level.

ROM Address: The PS/ValuePoint Ethernet Adapter has 16KB of read-only memory (ROM). Any of the following locations can be used for the hexadecimal ROM address. The default is D0000-D3FFF.

C8000-CBFFF	D0000-D3FFF	D8000-DBFFF
CA000-CDFFF	D2000-D5FFF	DA000-DDFFF
CC000-CFFFF	D4000-D7FFF	DC000-DFFFF
CE000-D1FFF	D6000-D9FFF	

Changing PS/ValuePoint ISA Adapter Configuration

To change the PS/ValuePoint Ethernet Adapter configuration, do the following.

1. Insert the Features Diskette in drive A, and power-on the computer to start the Ethernet Setup/Diagnostic program.
If the computer is already on, log off the network. If OS/2 is installed, shutdown the system and insert the Feature Diskette in drive A. Press and hold **Ctrl+Alt** then press **Del**.
2. Select **Option1. Set Adapter Configuration** from the Main Menu; then press **Enter**. The adapter address is displayed.
3. Press **Enter** to continue to the Adapter Configuration Menu. Follow the instructions to make specific changes.
4. Press **F10** to install the configuration changes.

Note: If two adapters are installed in the same computer, the default setting on one of the adapters must be changed. Ensure that no two adapters installed in the same computer share the same settings. Duplicate option settings will result in an error.

PS/2 ServerGuard Adapter

The ServerGuard Adapter has the following features:

Feature	Description
Microprocessor	16 MHz 80C186XL
Flash Memory	512KB
SRAM	256KB
NVRAM	8KB
Gate Array	Custom-control
Expansion Connectors	PCMCIA Type II (two) Slot A (upper slot) reserved for modem Slot B (lower slot) reserved
Main Battery Pack	7.2V dc NiCad
Backup Battery	3V Lithium
Other Features	Analog-to-digital Converter External Power Control Box (plugs into the ServerGuard Adapter)

The ServerGuard Adapter includes a PCMCIA Type II Modem which has the following features. (The modem is dedicated to the ServerGuard Adapter and is not accessible by computer software.)

Feature	Description
Data Speed	2400 bits per second (bps)
DAA	Country specific
DAA to telephone jack cable	Country specific
Other Features	Modem to Data Access Arrangement (DAA) cable

The ServerGuard Adapter is supported in the following systems:

Machine Type	Model
7546	411, 640, 641
8580	All Models
8590	All Models
8595	All Models
9577	All Models
9585	All Models
9590	All Models
9595	All Models

Cabling

The Data Access Arrangement (DAA) provides access to a local telephone system on the Public Switched Telephone Network (PSTN).

The External Power Control Box (EPCB) connects between the power connector on the computer, and an electrical outlet.

External DAA Cabling

Refer to “ServerGuard Adapter Parts” on page 306 for the external DAA for your country.

The following illustration shows the arrangement of the cables when using an external DAA.

- 1 Flat end of DAA Cable to modem
- 2 MiniDIN end of DAA Cable to External DAA
- 3 External DAA
- 4 RJ-11 end of PSTN Cable to External DAA
- 5 Other end of PSTN Cable to telephone outlet
- 6 Telephone outlet

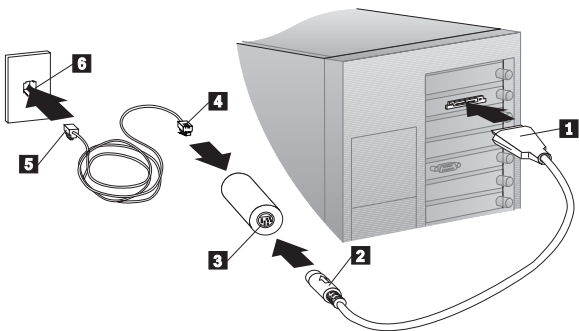

DAA Cable Check

The DAA cable, PSTN cable, and External DAA are wired with pin 1 connected to pin 1, pin 2 connected to pin 2, and etc.. A continuity check of the cables will determine if the cables are good.

External Power Control Box Cabling

Connect the external power control box to both the computer power supply connector and the ServerGuard Adapter power control connector:

- 1 Power Control Cable to ServerGuard Adapter
- 2 Power Supply Cable to system unit
- 3 Power Supply Cable to electrical outlet

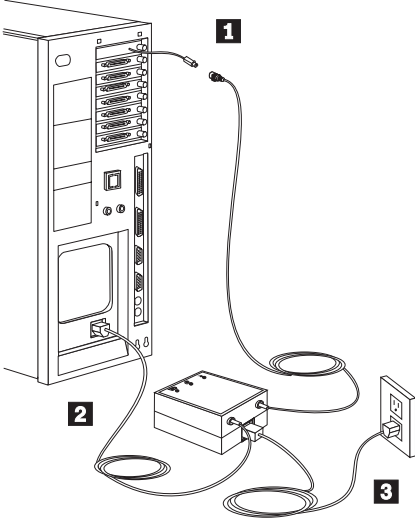

ServerGuard Adapter Symptom-to-FRU Index

Error codes and the FRUs that might be responsible for the failure are listed below. The most-likely failing FRU is listed first.

Symptom/Error	FRU/Action
No beep, power-on indicator does not come on, and fan does not run.	<ol style="list-style-type: none"> 1. Press Master Override Button on EPCB 2. External Power Control Box <p>Note: Bypass External Power Control Box by plugging electrical outlet directly into computer power supply prior to replacing FRU.</p>
Power Status LED is off during EPCB Diagnostic test.	<ol style="list-style-type: none"> 1. ServerGuard Adapter 2. External Power Control Box

Symptom/Error	FRU/Action
027501XX, 027503XX 027506XX, 027507XX	<ol style="list-style-type: none"> 1. ServerGuard Adapter 2. System Board
027502XX, 027504XX 027510XX, 027511XX 027533XX, 027534XX 027536XX, 027537XX	<ol style="list-style-type: none"> 1. ServerGuard Adapter
027509XX	<ol style="list-style-type: none"> 1. Remove redundant ServerGuard Adapters, run Auto Configuration program, then retest.
027512XX	<ol style="list-style-type: none"> 1. WMSELF.DGS diagnostics file missing. 2. WMSELF.DGS diagnostics file incorrect.
027535XX	<ol style="list-style-type: none"> 1. 3V Lithium Backup Battery. 2. ServerGuard Adapter
027554XX	<ol style="list-style-type: none"> 1. Internal Temperature out of range 2. ServerGuard Adapter
027555XX, 027556XX	<ol style="list-style-type: none"> 1. ServerGuard Adapter 2. System Power Supply
027557XX	<ol style="list-style-type: none"> 1. 7.2V NiCad Main Battery Pack 2. ServerGuard Adapter
027558XX, 027559XX 027560XX, 027561XX	<ol style="list-style-type: none"> 1. PCMCIA Type II Modem 2. ServerGuard Adapter

Symptom/Error	FRU/Action
027562XX	<ol style="list-style-type: none"> 1. External Power Control Box not connected 2. External Power Control Box 3. ServerGuard Adapter
027563XX, 027564XX	<ol style="list-style-type: none"> 1. External Power Control Box 2. ServerGuard Adapter
0275XXXX	<ol style="list-style-type: none"> 1. Update Diagnostic Software

Wireless Network

This section provides information on the IBM Wireless LAN. For additional help, refer to the user's guides for the workstation you are using.

ISA Bus Switch Settings: To install the adapter in a computer with an ISA bus, set the dip switches as shown below.

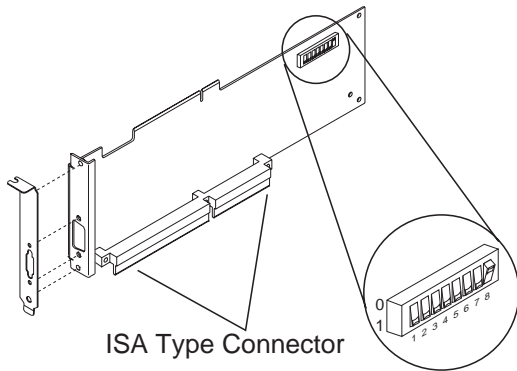

Table 5. ISA Dip Switch Settings

Switch	1	2	3	4	5	6	7	8
Position	0	0	0	0	0	0	0	1

Important

Refer to the values shown on the ISA adapter, DO NOT use the values shown on the switch.

The settings shown in Table 5 apply to most computer configurations. The interrupt level used by the IBM Wireless LAN adapter is determined by the position of switches 5 and 6.

The IBM Wireless LAN adapter does not support interrupt level sharing. Therefore, make sure that no other adapter in the computer uses the same interrupt level. If necessary, change the interrupt level of the IBM Wireless LAN adapter.

If you want to use interrupt level 9 for the IBM Wireless LAN adapter, make sure that no other adapter in the computer uses interrupt level 2.

ISA Mode Operations Parameters: The following provides the possible values for ISA mode operation parameters that you can select according to your system configuration:

Input/Output (I/O) base address (this is used by the

computer to identify and communicate with each individual adapter).

Table 6. I/O Base Address, ISA Mode

Switch Positions 1 2 3	I/O Base Address
0 0 0	86A0
1 0 0	96A0
0 1 0	A6A0
1 1 0	B6A0
0 0 1	C6A0
1 0 1	D6A0
0 1 1	E6A0
1 1 1	F6A0

RPL memory enable (this allows you to enable or disable the RPL memory).

Table 7. RPL Memory Enable, ISA Mode

Switch Position 4	RPL Memory
0	Disabled
1	Enabled

Interrupt level (this establishes the priority by which the adapter can interrupt the computer. The lowest value is given the highest priority).

To use interrupt level 9 for the IBM Wireless LAN adapter, make sure that no other adapter in your computer uses interrupt level 2.

Table 8. Interrupt Level, ISA Mode

Switch Positions 5 6	Interrupt Level
0 0	9
1 0	10
0 1	11
1 1	15

Direct memory access (DMA) arbitration level (this establishes the priority by which the adapter can access the computer memory. The lowest value is given the highest priority).

Table 9. DMA Arbitration Level, ISA Mode

Switch Positions 7 8	ISA DMA Level
0 0	0
1 0	1
0 1	3
1 1	Invalid

Wireless LAN Utilities Diskette: To use the utilities stored on the IBM Wireless LAN Utilities diskette, you must add four lines to the CONFIG.SYS file on the diskette. To do so, take the following steps:

1. Edit the CONFIG.SYS file supplied on the IBM Wireless LAN Utilities diskette.
2. Copy the four lines of Card and Socket Services DEVICE statements. These statements are determined by the type of ThinkPad and are supplied on the ThinkPad utilities diskette.

For example, in the DOS environment for an IBM ThinkPad 720C computer, the four lines to copy might be:

```
DEVICE=C:\IBMDSS 2.SYS
DEVICE=C:\IBMDOSCS.SYS
DEVICE=C:\DICRMU 2.SYS
DEVICE=C:\$ICPMDOS.SYS
```

Placement of Radio Modules: The IBM Wireless LAN adapter consists of an external unit and a controller card or a PCMCIA Credit Card. The external unit is called a **radio module**

The radio module contains the antenna. It is connected by cable to the controller card or the PCMCIA Credit Card.

Considering that each base must be located at the center of the cell it controls, cells should be arranged in a manner to cover the site. The following guidelines for radio module placement ensure reliable operation of the wireless network.

Place all radio modules:

- So that they are not hidden by metallic objects
- Far from moving objects such as fans or metallic doors
- Away from radiation sources that emit in the 2.4GHz frequency band such as microwave ovens.

In addition, place the base radio modules:

- Above the average furniture height, at least 1.5m above the floor
- Above dividing panels, shelves and so on
- At the center of the ceiling of a large room or corridor, or at the intersection of two corridors.

Modern buildings having metallic partitions are very common. IBM suggests that you install the base radio modules in the ceiling of corridors. Radio waves used by the IBM Wireless LAN are reflected along these partitions, and enter into offices through the doors or glass parts.

Error Management Overview: The IBM Wireless LAN software processes the events occurring in each base, such as:

- Hardware errors on wireless LAN controller cards
- Software errors during data transfer
- Significant events such as adapter load completion.

These events are logged in two files:

- IBMWLERL.LOG, which contains the most recent events.
- IBMWLERL.BAK, which contains older events.

In an **OS/2** environment there is an additional file: LANTRAN.LOG

All these events are listed in the manual, "Installing and Operating Your Network" delivered with the product.

The most critical events are reported to the network management system through simple network management protocol (SNMP) traps, and can be displayed on the network management station.

Using a network management system such as NetView/6000* or NetWare Management system (NMS) allows you to manage your network from a single point.

Running Adapter Diagnostics: To run the adapter diagnostics, do the following:

1. Insert the IBM Wireless LAN Utilities diskette in drive A.

Note: If the workstation has a PCMCIA Type II slot, make sure that you have correctly set up the IBM Wireless LAN Utilities diskette (see section "Wireless LAN Utilities Diskette" on page 99).

2. Restart the workstation as follows:

For an ISA computer, power-off the computer, then power-on the computer.

or

For Micro Channel or computers with the PCMCIA Type II slot, press **Ctrl+Alt+Del**.

3. Select **Diagnostics Utilities** from the main menu.
4. Wait for the diagnostics to complete and follow the recommended action.

FRU numbers are available in "Wireless LAN Adapter (ISA, Micro Channel Bus)" on page 309 and "Wireless LAN Adapter (PCMCIA Type II)" on page 310.

Note

If a hardware problem is not identified, see the "Installing and Operating Your Network" manual (part number 54G2072) for further information on troubleshooting.

If the problem persists:

1. Note the resulting diagnostic message and code.
2. Go to "Problem Resolution Worksheet" on page 104 and fill in the information on the worksheet.
3. Then call your IBM service representative or your dealer.

PCMCIA Credit Card Problems

Note

This section applies only to PCMCIA Type II slot DOS and Windows** wireless workstations in a Netware** environment.

If the PCMCIA Credit Card is not detected when you start the computer, do the following.

If you use Card and Socket Services or only Socket services, you can edit the CONFIG.SYS file and comment out the Card and Socket Services device statements (these statements are determined by the type of computer).

Then press **Ctrl+Alt+Del** to restart the computer.

If the problem persists, refer to the following procedure:

If you use neither Card and Socket Services, edit the NET.CFG file and add:

```
/R :C
```

to the following statement:

```
Enabler c:\xxxx\IBMWLENA.EXE
```

where C is a memory zone between C000 to EF00 in multiples of 100 and xxxx is the directory where the IBM Wireless LAN has been installed, for example, NWCLIENT.

Then press **Ctrl+Alt+Del** to restart the computer.

Note

If you are using only Socket Services you can edit the CONFIG.SYS file and add the Card Services device statement.

Interrupt Level or I/O Address Conflicts

Note.

This section applies only to PCMCIA Type II slot wireless workstations.

Interrupt levels or I/O address conflicts may occur after you install the IBM Wireless LAN software on a workstation.

If this happens, you can resolve the conflict by changing the value of the interrupt level or the I/O address used by the IBM Wireless LAN adapter. To do so, refer to the following procedures:

In a Netware environment for DOS and Windows workstations, edit the NET.CFG file and specify the following statements:

- For Interrupt level

```
int n
```

(n can be 3,4,5,7,9,10,11,12, or 15).

- For I/O Address

```
port xxxx
```

(xxxx can be from 200 to 2FO, from 300 to 360, or from 400 to FFE0 in multiples of 10).

In an OS/2 environment, for DOS and Windows workstations, change these wireless adapter parameters through the LAN Support Program diskette.

Checking the Base Configuration (OS/2

Environment): To verify that all prerequisites have been installed as defined by the configuration for your base, refer to Table 10 on page 103.

If all the prerequisites have been installed, access LAPS and verify the options, binds and parameters that were selected during installation. If they are correct, you must re-install.

<i>Table 10. OS/2 Prerequisites for Base and NAP station</i>					
Prerequisites	Base Stand alone	Base Wired Stand alone	Base Wired Lan Cell with NAP	Base Wired Lan Cell without NAP	NAP only
TCP/IP	N/A	N/A	V2.0	V2.0	V2.0
TCP/IP Using Network Management	V2.0 (Network Manager is WNM)	V2.0 and CSD UN50382	V2.0 and CSD UN50382	V2.0 and CSD UN50382	V2.0 and CSD UN50382
IBM IEEE 802.2	NTS/2 V1.0	NTS/2 V1.0	NTS/2 V1.0	NTS/2 V1.0	NTS/2 V1.0
IBM Wireless LAN Bridge	N/A	NTS/2 V1.0 with CSD level 7020	NTS/2 V1.0 with CSD level 7020	NTS/2 V1.0 with CSD level 7020	N/A

Note:

1. Install and bind TCP/IP with your device driver depending on your backbone adapter.
If you have a problem, check your IP connection. To do so, type ping xxxxx at the OS/2 prompt, where xxxxx is the value of an IP address of your network.
2. Bind IBM IEEE 802.2 with the device driver of your wireless adapter.
3. Bridged configuration:
LAPS:
 - a. Select the IBM Wireless Network adapter for Base with bridge from the adapter list. Bind with the IBM Wireless LAN Bridge.
 - b. Bind the IBM Wireless Network adapter with IBM IEEE 802.2.
 - c. Select the IBM Token ring Network Adapter from the adapter list. Bind with the IBM Wireless LAN Bridge. Supervisor: Bridge option enabled.

Warning

IBM Wireless LAN bridge can **not** be installed on the same computer as Routexpander/2 Source Routing Bridge.

LAPS Installation Problem: If you cannot run the IBM Wireless LAN because LAPS aborted during installation, do **not** reboot the computer when prompted by the instructions displayed on your screen. Go to the OS/2 Install directory and erase the file IBMLANLK.LST, then restart your installation.

Problem Resolution Worksheet: Before calling your service representative, do the following.

1. Make a copy of the problem resolution worksheet.
2. Collect and fill in the information listed in the problem resolution worksheet.
3. Collect the part numbers.

In the section following the worksheet, there is an explanation of how to obtain the data requested.

You should answer the following questions:

Does the problem occur on only one wireless workstation or on several?

If on several, are all the affected wireless workstations in one cell?

Does the problem occur on only one base or on several?

Are all bases in the IBM Wireless LAN affected?

The Problem Resolution worksheet is on the following page.

<i>Table 11. Problem Resolution Worksheet</i>	
Description of the problem	
Level of IBM Wireless LAN software.	
Level of IBM Wireless LAN microcode.	
PS model and type (see the documentation for your computer)	
Bus type (ISA, MCA, or PCMCIA) (see the documentation for your computer)	
Disk type (ESDI or SCSI) (see the documentation for your computer)	
Operating System and Level	
Protocol stack used - level and Type of application (contact your network administrator)	
Information contained in the error log files IBMWLERL.LOG and IBMWLERL.BAK (for bases) LANTRAN.LOG for OS/2 environment (copy the files onto a diskette)	
Any other significant displayed messages	
Network Configuration Number of cells Number of bases Number of workstations Type of backbone attachment	

Obtaining the Necessary Data

- Find the level of IBM Wireless LAN software:
 In a NetWare environment (Base), type `MODULE` at the server prompt on the system console and note the information for the following modules:
 - IBMWLCOM.NLM
 - IBMWLNAP.NLM
 - IBMWLWNC.NLM
 - IBMWLWCA.NLM
 - IBMWLERL.NLM
 or
 - IBMWLPRX.NLM
 - and IBMWL.LAN

For all other environments, go to the directory where you have installed your software and refer to the following procedures:

- In a NetWare environment, for DOS and Windows workstations, type `IBMWL1` and note the information that you require.
 - In an OS/2 environment, for DOS and Windows workstations, type `IBMWL2` and note the information that you require.
 - In an OS/2 environment (base and OS/2 workstation), type `SYSLEVEL` and note the information that you require.
2. Find the level of IBM Wireless LAN Microcode. To do so, follow these steps:
- a. Insert the IBM Wireless LAN Utilities diskette in drive A.
 - b. Restart your workstation.
 - c. Select **Diagnostic Utilities** from the main menu.
 - d. When the first set of instruction panels is displayed, press **Enter**.
 - e. When the second set of instruction panels is displayed, access **Adapter Vital Product** and note the Product Change Level.

Related Service Information

Important

The service procedures are designed to help you isolate problems to a FRU. They are written with the assumption that you have received model-specific training on all PS/2 computers, or that you are familiar with the computers, functions, terminology, and the reference information provided in this manual.

ACPA/A Advanced Diagnostic Tests	108
CSD (DOS) Version Level Check	108
CSD (OS/2) Version Level Check	108
Combined FRUs Diagnostics	108
Display Adapter 8514/A	109
Display Self-Test	110
Fax/Modem Checkout	112
How to Use a Symptom-to-FRU Index	114
Identifying Adapters	122
Keyboard Voltage Check	123
Memory-Module Kit Identification	123
Memory Problems	125
Option Microprocessor Jumper (76, 77)	130
OS/2 Problems during a New Installation	130
OS/2 Trap Errors	131
PCMCIA Diagnostics (PS/2 E Model 33)	133
PCMCIA Adapter Switch Settings	134
PCMCIA PC Card Lock Override	134
Printer Errors	134
Processor Board Installation (90, 95)	135
Processor Upgrade (Models 50/50Z/60 - 486SLC2) Switch Settings	136
Processor Upgrade (Models 70/80 - 486DX33) Switch Settings	136
Processor Upgrade (Model 70/80 - 486DX33) FRU Isolation	136
Processor (Px) Label Cross-reference	137
Power Supply Voltage Check	138
Real-Time Clock Problems	150
Remote Power-on Jumper (95)	150
Running Automatic Configuration	150
ServerGuide CDs (Type 86XX)	151

ACPA/A Advanced Diagnostic Tests

To access the Advanced Diagnostic mode, select **F2**. The diagnostic program consists of the following:

Audio Output Tone (Tone): Select this item from the Main Menu to test the right and left audio output channels of the control-panel assembly. The test allows you to choose the frequency and amplitude of the tone. To start the oscillator, select **Oscillator Start** or press **Alt+O**. To change the frequency and amplitude of the tone, select **Change Oscillator Values** or press **Alt+V**.

Microphone Input Loop (Loop): Select this item from the Main Menu to test the microphone input from the audio adapter and control-panel assembly. To start the test, select **Mic into R and L Out** or press **Alt+Z**.

Microphone Gain Toggle (Toggle): Select this item to toggle between the high and low gain settings on the audio adapter. To toggle between the settings, select **Mic Gain** or press **Alt+M**.

CSD (DOS) Version Level Check

Many problems with DOS are fixed by Corrective Service Diskettes (CSD). If you think that the problem you are experiencing has been fixed by a CSD, check the CSD version level.

To determine the CSD level on the computer you are servicing, type **VER** at the DOS prompt, then press **Enter**.

CSD (OS/2) Version Level Check

To determine the OS/2 level on the computer you are servicing, type **SYSLEVEL** at the OS/2 prompt, then press **Enter**.

Combined FRUs Diagnostics

If an adapter or device consists of more than one FRU (for example a card plugged into an adapter), an error code might be caused by either FRU. Before you replace a multi-FRU adapter or device, try removing or exchanging each FRU, one by one, to help you determine the problem.

Display Adapter 8514/A

Use this illustration to determine the correct placement of the jumper on the adapter.

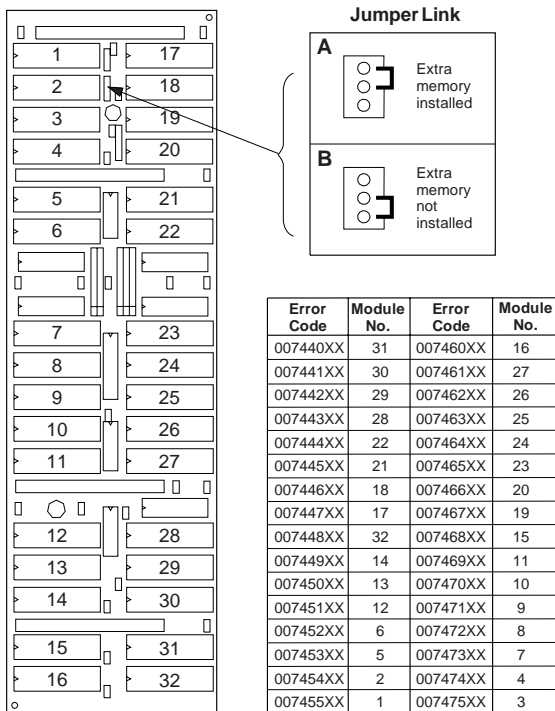

Display Self-Test

Before performing this test, be sure you are familiar with the information under "Display Considerations" on page 111.

Note

Before replacing a display, check the following:

- 8506 and 8508 displays must be connected to an Image adapter.
- 63XX and 85XX systems support either 63XX or 85XX displays.
- 85XX systems with an XGA-2 adapter support 95XX displays.
- 95XX systems support either 63XX, 85XX, or 95XX displays.

If the screen is rolling, replace the display assembly. If that does not correct the problem, replace FRUs in the following order until the problem goes away:

1. Display adapter (any type)
2. System board
3. Bus adapter (if used)

If the screen is not rolling, do the following:

1. Power-off the computer and display.
2. Disconnect the display signal cable.
3. Power-on the display.
4. Turn the contrast to its maximum position.
5. Turn the brightness control to the center position.

Check for the following conditions:

You should be able to vary the screen intensity by adjusting the contrast and brightness controls. The screen should be white or light gray, with a black margin (test margin) on the screen.

Note: The location of the test margin varies with the type of display. The test margin might be on the top, bottom, or one or both sides.

If you do not see any test margin on the screen, replace the display. If there is a test margin on the screen, replace the FRUs, in the following order, until the problem goes away:

Note: Certain adapter failures can cause video problems. Before replacing any FRUs, remove any option adapters to see if the problem disappears.

1. Display adapter (any type)
2. System board
3. Bus adapter (if display adapter is used)
4. Display

Display Considerations: If you experience problems with a PS/2 display and the Advanced Diagnostic video test and the display self-tests do not indicate a problem, consider the location of the display and any surrounding devices. Certain fluctuating low-frequency magnetic fields can cause the screen to distort, jitter, or roll. These magnetic fields are generally present around transformers, small appliances, and even nearby florescent lighting fixtures. If you experience this problem, you might have to move the device or the display. Displays that are too close to each other (less than 12 inches) *could* cause similar problems.

Note

Because of the differences in the Earth's magnetic fields, displays are designed to be used in a specific hemisphere. For example, if a display marketed for use in the Southern Hemisphere is relocated to the Northern Hemisphere, the colors will probably be distorted. The parts catalog lists FRU numbers and model numbers for Northern and Southern Hemisphere displays.

You should avoid moving a color display *while it is powered-on*. The movement can result in some screen discolorations. If this happens, to correct the colors, power-off the display for twenty minutes (the display automatically degausses (demagnetizes) the screen after it is off for twenty minutes).

It is possible for a display to cause diskette drive read/write errors if the drive and the display are too close. Distance between displays and diskette drives should be at least 3 inches.

Warning

You can damage the display or adapter if you do not power-off the display and computer before connecting or disconnecting the display cable. This is especially important when using the XGA-2 subsystem because displays of varied refresh rates are supported. Reconnect the display cable *before* powering-on the computer because the display type and the appropriate refresh rate is determined during POST. After POST, any display change is not detected.

Fax/Modem Checkout

001

- Power-off the computer.
- Ensure that the modem is installed correctly.
- Ensure that the public switch telephone network (PSTN) cable and the data access arrangement (DAA) cable, if installed, are connected correctly.

If you need to correct one of the above conditions, do so now; then continue.

- Power-on the computer.
- Insert the IBM Data/FAX Modem diskette into the default diskette drive.
- If you are servicing a High Speed Internal Data/Fax Modem (Models FC3632 and FC3650), at the DOS prompt (for example, A:\), type **IBMDIAG**; then press **Enter**.
- If you are servicing a PCMCIA Data/FAX Modem (Models FC3634 and FC3635), at the DOS prompt (for example, A:\), type **ESTDIAG**; then press **Enter**.
- Follow the instructions on the screen. (If you need help, press **F1**.)

DID THE DIAGNOSTIC TESTS DETECT AN ERROR?

Yes No

002

The diagnostic tests have completed successfully. If you suspect a problem, go to Step 004.

003

Go to "Symptom-to-FRU Index (AT Bus)" on page 12.

004

- Check the PSTN cable and the DAA cable, if installed, for continuity.

IS THE CABLE(S) GOOD?

Yes No

005

Replace the defective cable(s).

006

- Have the customer transmit a call.

WAS THE CALL TRANSMITTED SUCCESSFULLY?

Yes No

007

If installed, replace the external DAA. If you do not have an external DAA installed, or replacing the external DAA does not correct the problem, replace the modem.

008

- Have the customer receive an incoming call on the modem.

WAS THE INCOMING CALL RECEIVED?

Yes No

009

If installed, replace the external DAA. If you do not have an external DAA installed, or replacing the external DAA does not correct the problem, replace the modem.

010

The diagnostic tests have completed successfully. If you still suspect a problem that is not software related, replace the External DAA; then replace the modem.

How to Use a Symptom-to-FRU Index

Always start with the General Checkout procedure. In the MAP, you might be sent to the Symptom-to-FRU Index. There, you will find a list error symptoms, error codes, and the possible causes. The most-likely cause is always listed first, and it is in bold type.

Another use for the Symptom-to-FRU Index is to help you decide which FRUs to bring with you on a service call. Try to get the customers POST error, or error symptom from the dispatcher.

The MAP can send you to a Symptom-to-FRU Index under various conditions. Listed below are the actions to take for most conditions.

Symptom / Response	Information / Action
POST Error (except I999 range)	Use the first error that appears on the screen. If multiple error codes appear, diagnose them in the order that they appear (the multiple errors might be false errors).
POST Error in the I999XXXX Range	Refer to "IML and IPL Errors" on page 55.
Any POST Error Plus an Incorrect Audio Response	Diagnose the error code first.
No POST Error	Refer to "Symptoms" in the index.
System Starts Up in BASIC	Refer to "IML and IPL Errors" on page 55.
Error Range is Not Listed	An additional service package is required for the device generating the error. Refer to that service package.

Error Code Format: This section provides an explanation of the encoded SCSI and non-SCSI Post error codes and detailed information about each code.

Error messages are displayed on the screen as three, four, five, eight, twelve or, thirteen digits. An "X" in an error message can be any number. The shorter POST errors are highlighted in the Symptom-to-FRU Index. Some digits will represent different information for SCSI errors versus non-SCSI errors.

The following figure shows which digits display the shorter POST errors. The figure also defines additional SCSI information.

Notes:

1. Non-IBM device error codes and documentation supersede this list.
2. Duplicate SCSI ID settings will cause misleading error symptoms or messages.

RDDDDLSCB QEET

```

Test state
Error code Extension
Qualifier

Bus ( =internal 1=external)
Capacity of the device
Slot number of the device
LUN (usually )
PUN (SCSI ID #)

Device Number
Reserved Digit (usually )

```

As an example, if you have SCSI error code **021050A0**, each digit decodes as follows:

Digit	Information
0	Reserved digit (usually 0)
210	Device number 210 indicates hard disk
5	SCSI ID assigned is 5
0	Logical Unit Number (not used, usually 0)
A	The device capacity is 60MB (A = 60MB)
0	The device is connected to the internal bus

RDDD Codes for Adapters

RDDD	Device Type or Information
0037	SCSI on the system board
0096	SCSI adapter with cache
0112	SCSI adapter without cache
0206	SCSI-2 adapter

RDDD Codes for Devices

RDDD	Device Type or Information
0208	Unknown device type
0209	Direct access - removable media, and/or other than 512 byte blocks
0210	Direct access - hard disk, 512 byte blocks
0211	Sequential access (tape)
0212	Printer
0213	Processor
0214	Write Once, Read Multiple (W.O.R.M.)
0215	Read only (CD-ROM)
0216	Scanner
0217	Optical memory (read/write optical disk)
0218	Changer (multiple tray CD-ROM)
0219	Communications

B Codes

B	Device Type or Information
0	Dual SCSI adapter (internal bus)
1	Dual SCSI adapter (external bus)

QEET 0000 Codes

Refer to this list if the "DDD" indicates an adapter, followed by a QEET of 0000. For example, 01120100 0000.

PLSC	QEET	Information
0100	0000	On systems with NVRAM, SCSI setup data not located, or the checksum did not verify. On systems without NVRAM (Model 50 for example), setup data must be on the 1st hard disk.
0200	0000	Configuration error. No hard disk found at PUN 6, LUN 0 for 161,162,165 system error path. Might be an unsupported configuration.
0300	0000	No space available in extended BIOS data area for SCSI data table (possibly too many adapters installed).
0400	0000	ROM modules not found on adapter (IML based systems only). Running setup might correct it.
0500	0000	ROM checksum error on 2nd 16K portion of 32K ROM
0600	0000	ROM access control port error

QEET Errors (other than 0000)

These are specific "QEET" error codes (preceded by a "DDD" indicating an adapter).

Note: A number in slot "S" indicates an error on the adapter, (or device attached to the adapter) in slot "S." If "S" is 0, suspect the system board.

QEET	Information
001x	8032/80188/80C186 ROM test failure
002x	Local RAM test failure
003x	Bad fuse, or bad termination, or local RAM address failure on SCSI adapter if "RDDD" is 0112.
004x	Internal peripheral test failure
005x	Buffer control chip test failure, or LTB failed, (or system-board SCSI failed if "RDDD" is 0037)
006x	Undefined error condition, or buffer RAM test failure on SCSI adapter if "RDDD" is 0096
007x	System interface control chip test failure
008x	SCSI internal interface test failed
00Ax	SCSI external interface test failed
107x	Adapter hardware failure
10Cx	Command failed
10Ex	Command error (invalid command or parameter)
10Fx	Sequencing error
110x	Adapter internal error log contains entries. (Reported if no other errors on adapter exist.)
180x	Time out
181x	Adapter busy error
182x	Unexpected interrupt presented by adapter
183x	Adapter register test failure
184x	Adapter reset failure
185x	Adapter buffer test failure (on cached adapters)
186x	Adapter reset count expired
187x	Adapter registers not cleared on reset
188x	Card ID in adapter microcode did not match ID in POS registers
190x	Expected device did not respond
19Yx	DMA arbitration level conflict (Y = assigned arbitration level)
220x	Adapter hardware error
221x	Global timeout on adapter (device did not respond)
222x	Adapter DMA error
223x	Adapter buffer defective
224x	Command aborted by adapter
301x	Invalid parameter in SCB
303x	Command not supported

QEET	Information
304x	Command aborted by system
305x	Command rejected (buffer not disabled)
306x	Command rejected (Adapter diagnostic failure)
307x	Format rejected
308x	Assign rejected (command in progress)
309x	Assign rejected (device already assigned)
30Ax	Command rejected (device not assigned)
30Bx	Command rejected (maximum LBA exceeded)
30Cx	Command rejected (16 bit card slot address range exceeded)
313x	Invalid device for command
3FFx	Status not returned by adapter
401x	Recovered error (not an error condition)
402x	Device not ready
403x	Device medium error
404x	Device hardware error
405x	Illegal request for device
406x	Device unit attention would not clear
407x	Device data protect error
409x	Device vendor unique error
40Ax	Copy operation aborted by device
40Bx	Device command aborted
40Cx	Device search data command satisfied
40Dx	Device volume overview (residual data remains in buffer)
40Ex	Device mismatch (source data did not match medium data)
500x	Check condition on device, no sense data returned
501x	No index or sector
502x	Seek incomplete
503x	Write fault
504x	Drive not ready
505x	Drive not selected
506x	No track zero found
507x	Multiple drives selected
508x	Logical unit communication failure
509x	Head positioning error (track following error)
510x	CRC or ECC error on ID field
511x	Unrecoverable read error
512x	No address mark (ID field)
513x	No address mark (data field)

QEET	Information
514x	Record not found
515x	Seek error
516x	Data synchronization error
517x	Recoverable read (without ECC) error
518x	ECC recovered read error
519x	Defect list error
51Ax	Parameter overrun
51Bx	Synchronous transfer error
51Cx	Primary defect list not found
51Dx	Compare error
520x	Invalid command
521x	Illegal logical block address (LBA)
522x	Illegal function for device type
524x	Illegal command block field
525x	Invalid LUN
526x	Illegal field in parameter list
528x	Media changed
529x	Power-on or bus device reset occurred (not an error)
52Ax	Mode select parameters changed (not an error)
531x	Medium format corrupted
532x	Defect spare location unavailable
540x	Device RAM failure
541x	Data path diagnostic failure
542x	Power-on diagnostic failure
543x	Message rejected
544x	Internal controller error
545x	Device was unable to reconnect
547x	Interface parity error
548x	Initiator detected error
549x	Illegal command or command out of sequence error
5F0x	Format in progress (not an error)
5F1x	Spinup in progress
601x	SCSI bus reset occurred
602x	SCSI interface fault
610x	Selection timeout error (device not available)
611x	Unexpected bus free
612x	Mandatory SCSI message rejected
613x	Invalid SCSI phase sequence
620x	Short length record error
702x	Device not ready (removable media devices)

QEET	Information
704x	Device not ready (non-removable media devices)
728x	Media changed error would not clear
731x	Medium format corrupted (format unit interrupted - format must be issued again)
7F0x	Format in progress (prior format unit issued being completed)
7F1x	Spinup in progress

Q Codes

All error codes with "Q" = 1 are developed using information returned by either an adapter or device. The "Q" value defines the origin of the "EE" code that is reported. Error codes (EE) with "Q" = 4 or 5 may be reported that are not listed here or can actually have a definition other than that given, depending on the device.

"Q"	Information
2	Command error field of command complete status block returned by the adapter
3	SCSI Status field of the command complete status block or command error field values indicating software problems (< 20H)
4	Sense key value returned by a device
5	Additional sense byte (byte 12) of sense information from device
6	Device error code field of command complete status block
7	Device errors not normally considered an error, but considered an error based on when the code was returned (medium corrupted error on device with non-removable media)

Test Status Codes

"T"	Information
O	Not applicable for error code
A	Adapter initialization error
B	Adapter reset
C	Adapter register test
D	Adapter buffer test phase 1 (on cached adapters)
E	Adapter buffer test phase 2 (on cached adapters)
F	Adapter buffer test phase 3 (on cached adapters)
G	Adapter buffer test phase 4 (on cached adapters)
H	Adapter (buffer enable, buffer size, retry, enable)
I	Device assignment sequence
J	Device not ready (initial unit attention clearing)

"T"	Information
K	Device reset
L	Device starting phase
M	Device in process of starting
N	Device block size determination
O	Device self-test
P	Device single block read (LBA)
Q	Device double block read (LBA)
S	Error occurred after device testing completed

Identifying Adapters

Adapters can usually be identified by examining the adapter and looking for special chips, sockets or connectors. I/O adapters can be identified by looking at the number of pins in the I/O connector and the gender of the connector.

"F" connectors (TV type) indicate a broadband network adapter.

"BNC" connectors (mini-twistlock) indicate a 3270 emulation adapter or possibly, if it is an "AT Bus" adapter, it could be a Cluster adapter. The 3270 adapter does not have switches, the Cluster adapter does.

9-pin Male connectors usually indicate a serial port.

9-pin Female connectors usually are display adapters but could also be Token Ring adapters, if it is an "AT Bus" adapter. If it is a short card, it is a Token Ring. If it is a long card, it is a display adapter. If the adapter is for the Micro Channel, it is a Token Ring adapter. IBM does not market 9-pin display adapter for Micro Channel systems.

15-pin Male (2 rows of pins) adapters are 5250 or 36/38 Emulation adapters. These two adapters are the same and differ in name only, depending if it is an AT Bus or Micro Channel adapter.

15-pin (3 rows of pins) Male connectors could be the Page Printer adapter (double card) or an Ethernet (single card), if it is a Micro Channel card, or it could be a game adapter (short card) or a Page Printer adapter (double card) if it is an AT Bus adapter.

15-pin (3 rows of pins) Female connectors, on an AT bus, indicate a PS/2 display adapter. If it is a Micro Channel adapter, it might be an 8514/A adapter (double card with many sockets on the full-length daughter card), an XGA* adapter, (single card with no sockets except for the 8 memory modules), or an Image Adapter (two sets of memory sockets and connectors for daughter cards).

25-pin Male connectors indicate some type of serial adapter. It could be a multiprotocol adapter or a scanner adapter. Many 25-pin connectors do not use all of the pins. Some of the pins might be omitted on both adapters and system board ports.

25-pin Female connectors indicate a parallel adapter.

* Trademark of the IBM Corporation.

Keyboard Voltage Check

Note: If a mouse or other pointing device is attached, remove it and see if the error symptom goes away. If the symptom goes away, suspect that the mouse or pointing device is defective.

Check the connector voltages at the keyboard end of the cable (all voltages are plus or minus 5%).

Standard Connector

Pin	Voltage (Vdc)
1	+5.0
2	0 (Not Used)
3	Ground
4	+5.0
5	+5.0
6	0 (Not Used)

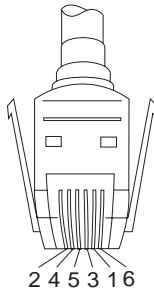

If the voltages are correct, replace the keyboard. If the voltages are not correct, suspect the keyboard cable, then the system board.

Memory-Module Kit Identification

Some early memory module kits are not labeled with a FRU number. The following information provides methods of identification.

There are four key identifiers:

1. The chip size: narrow or wide
2. The chip placement (horizontal, vertical, both, 1 side or 2 sides)
3. The speed suffix shown on the individual chips (7=70ns, 8=80ns, 85=85ns)
4. The module ID resistors (R1=85ns, R2=80ns)

Memory-Module Kit 1A and 1B

Kit **1A** and **1B**, show 10 or more chips mounted horizontally, vertically or a mixed pattern. If there are chips on one side of the board, it is 1MB. If there are chips on both sides, it is 2MB. (A small number of 8MB kits were also manufactured in this configuration.) The suffix on the chip, for example, -8, -85 is important.

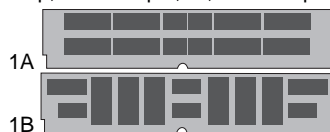

Memory-Module Kit 2L and 2R

Kit **2L** shows 10 wide chips with resistors across the top, but not on the end. If there are chips on one side, it is 4MB; two sides it is 8MB.

Kit **2R** shows 9 or 10 chips per side, *all* mounted vertically. If there are two resistor locations on the right end labeled R1 and R2, it is 2MB. (R1 = 85ns, R2 = 80ns, R1 + R2 = 100ns.) There will either be 9 or 10 chips.



Memory-Module Kit 3

Kit **3** has 6 chips per side spaced evenly. If all the chips are the same size, (3R) it is 1MB. If the two center chips are smaller than the 4 outer chips, (3L) it is 4MB. These could be any speed.



Memory-Module Kit 4A and 4B

Kit **4A** and **4B** are both 4MB. **4A** has 6 closely spaced chips on each side. There are no resistors, and it is 85ns (there might be a tiny FRU number on the end chip.) **4B** shows the front and rear of another 4MB chip configuration. There are 8 chips on the front, and 4 on the rear.

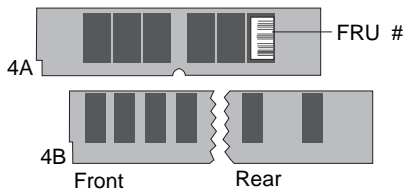

Memory Problems

Models 50, 55, 60, 65, 70, and 80

Note: For other Models, see the following information.

Finding the Failing Memory

Note: Running customer diagnostic tests will deallocate defective memory. After you replace defective memory, run the memory diagnostic test to enable the replacement memory. Then, restart the computer and rerun the same test to validate the installed memory-module kits.

Use the following procedure when you suspect a problem with the system memory.

1. Run the advanced-memory diagnostic test. If the test does not indicate which memory-module kit failed, or if the system hangs, try running the test from the System Diskettes. If you still cannot identify which memory-module kit failed, return here and continue with the next step.

Note: If a screen message appears, asking if you have replaced a specific memory-module kit, suspect that *it* is the failing kit.

2. Using a known-good kit, exchange each kit, one at a time, and repeat the memory diagnostic test until you find the defective kit. Replace *only* the defective kit. If the kits are not the problem, suspect:
 - Riser Card (if used)
 - Memory Expansion Adapter (if used)
 - System Board

Models 53 (9553-xBx) 56, 57, 76, 77, 85, 90, and 95

On these systems, the "X" digit of the POST error (for example, 00020xXx), indicates the socket location.

Determining Failing Memory Location

"X" digit equals	56, 57 Socket	76, 77 Socket	90 Socket	85, 95 Socket
X=1	Mem 1	Mem 1	J1 (J11)	A1
X=2	Mem 3	Mem 3	J3	B1
X=3	Mem 2	Mem 2	J2	A2
X=4	Mem 4	Mem 4	J4	B2
X=5			J1 (J14)	A3
X=6			J2	B3
X=7			J3	A4
X=8			J4	B4
X=U	Unknown			

When a mixture of 4MB, 8MB, and 16MB (or larger) memory-module kits are installed in the 9585-xKx, and

9585-xNx computers, the smaller kits must be installed in the higher-numbered connectors (A4/B4 is the highest), and the larger kits in the lower-numbered connectors (A1/B1 is the lowest).

Determining Memory Type, Size and Speed

The “Y” digit of the POST error (for example, 00020xxY), indicates the type, size, and speed.

“Y” digit equals	Type	Size	Speed
Y=0	Parity	4MB	80ns
Y=1	Parity	2MB	100ns
Y=2	Parity	1MB	100ns
Y=4	Parity	4MB	70ns
Y=5	Parity	2MB	85ns
Y=6	Parity	1MB	85ns
Y=8	Parity	8MB	80ns
Y=9	Parity	2MB	80ns
Y=B	Parity	8MB	70ns
Y=C	Parity	2MB	70ns
Y=D	Parity	2MB	120ns
Y=E	Parity	1MB	120ns
Y=K	ECC	16MB	70ns
Y=Q	ECC	4MB	70ns
Y=R	ECC	32MB	70ns
Y=S	ECC	8MB	70ns
Y=T	ECC	2MB	70ns
Y=Z	Unknown		

If you are still unable to determine which memory-module kit failed, follow the isolation procedure under “Finding the Failing Memory” on page 125.

Determining Models 90/95 Processor Type

On these models, memory operation differs with each type of processor board (type 1, 2, or 3). Use any of the three methods in the “Processor Board Matrix (90, 95)” to determine which one it is, then continue with the appropriate memory section.

Processor Board Matrix (90, 95)

1. Go to the Diagnostic Main Menu and select **Display revision levels** (you might have to select **More utilities** first). Note the submodel code displayed on the screen. (The customer can use this screen to tell you the submodel code.)
2. Read the FRU number printed near the card-edge of the processor board.
3. Look for a second label (marked P1 - PC) to the right of the front serial number of the system. The second label indicates that the processor board has been upgraded.

The following table converts the model code, submodel code, FRU number, reference diskette type, or the second label to the processor type.

Mod	Sub Mod 90	Sub Mod 95	Processor Board FRU Number and Description	2nd Lab.	Ref Disk Type
0GX	2D	2C	92F0049 486SX 20	--	1
0JX	11	14	64F0201 486 25	P1	1
0KX	13	16	64F0198 486 33	P2	1
0MX	2B	2A	92F0048 486 50	P3	1
0GX	2F	2E	92F0065 487SX 20	P4	1
0HX	57	58	92F0079 486SX 25	P5	2
0HX	59 ¹	5A ¹	92F0079 486 SX25 ¹	P6	2
0LX	3F	40	92F0161 486DX2 25/50	P7	2
0HX	5B ²	5C ²	92F0079 486 25/50 ²	P8	2
0MX	29	28	57F1597 486 50	PA	3
0NX	43	42	61G2343 486DX2 33/66 ³	PB	4
0PX	45	46	92F0120 586DX2 66	PE	4
0NX ⁴	N/A	44	61G2343 486DX2 33/66 ³	PB	4
0PX ⁴	N/A	47	92F0120 586DX2 66	PE	4

¹ Also has a 487SX processor (FRU 92F0100).

² Also has a 486 processor (FRU 92F0147).

³ Has built-in Level 2 cache.

⁴ Model 9095A

Memory (Type 1 Processor Boards)

Only interleaved memory configurations are supported. The system memory-module kits operate in pairs. Each pair must be the same memory size, speed, and type.

On the Model 90, the pairs are J1 & J3, J2 & J4, on each riser card.

On the Model 95 the pairs are A1 & B1, A2 & B2, A3 & B3, A4 & B4, on the system board.

Only *parity* (70ns, 80ns and 85ns) kits are supported. Minimum operating requirement is one *pair* of 1MB kits. Total system memory capacity is 64MB.

Memory (Type 2 Processor Boards)

Interleaved and noninterleaved memory configurations are supported. If the kits are installed in pairs of the same memory size, speed, and type, the kits will run in interleaved mode. Any other configuration is supported, but will run in noninterleaved mode.

On the Model 90, the pairs are J1 & J3, J2 & J4, on each riser card.

On the Model 95, the pairs are A1 & B1, A2 & B2, A3 & B3, A4 & B4, on the system board.

Only *parity* (70ns and 80ns) kits are supported.

Minimum operating requirement is one 2MB kit. Total system memory capacity is 64MB.

Memory (Type 3 Processor Boards)

Only interleaved memory configurations are supported. The system memory-module kits operate in pairs. Each pair must be the same memory size, speed, and type.

On the Model 90, the pairs are J1 & J3, J2 & J4, on each riser card.

On the Model 95, the pairs are A1 & B1, A2 & B2, A3 & B3, A4 & B4, on the system board.

Parity (70ns, 80ns, and 85ns) or Error Correcting Code (ECC) (70ns) kits are supported (but not a combination of both). Minimum operating requirement is one *pair* of 4MB ECC kits or one *pair* of 1MB *parity* kits. Total system memory capacity is 64MB.

Using the Low-Level Format Program:

Warning: The advanced-diagnostic format program (referred to as a *low-level format*), is different from the operating system format program. The operating-system format program will not erase the System Partition; the low-level format program *will*. It also will erase the system programs and completely clear the hard disk. If the hard disk is working, make a backup copy of the System Partition and all the files on the hard disk before you use this program. (If you do not know how to make a backup copy of the System Partition, see "Backing up the System Partition" on page 427.) To backup all of the files, see the operating system documentation. (It might take up to two hours to run the low-level format program, depending on the disk capacity.)

When to Run the Low-Level Format Program

There are three reasons to run this program:

1. You are installing software that requires a low-level format.
2. You get recurring messages from the diagnostic tests telling you to run the low-level format program on the hard disk.
3. You want to try this as a last resort before replacing a failing hard disk drive.

How to Run the Low-Level Format Program

1. Power-on the computer.
2. Start the system programs (as described in "Starting System Program Diagnostics" on page 425).
3. When the Main Menu appears, press **Ctrl+A**.
4. When the Advanced Diagnostic Menu appears, select **Format Hard Disk**. Then, follow the instructions on the screen.

Preparing the Hard Disk for Use

When the low-level format program completes, you must copy all the files to the hard disk. Before you can copy the files, you must:

1. Create the System Partition (if the hard disk drive had a System Partition) using the Restore the System Partition utility program from the system programs on the System Diskettes.
2. Format the hard disk using the operating system. (The commands vary with the operating system. Refer to the operating system manual for a description of the program commands to use.)
3. Install the operating system.

You are now ready to reinstall the files.

Option Microprocessor Jumper (76, 77)

The speed jumper (labeled SPD) is on the system board near the option microprocessor socket. The jumper changes the speed of the option microprocessor (if installed).

Note: Operating a microprocessor at a speed greater than it is designed for can cause intermittent problems.

The jumper settings are:

Speed	Jumper Settings
25MHz	Position jumper (SPD) over the middle and rear pins.
33MHz	Position jumper (SPD) over the front and middle pins.

OS/2 Problems during a New Installation

If you have determined that you *do not* have a hardware failure, and you cannot get the operating system to work, assist the customer in recopying the OS/2 software to the hard disk. **If this is not a new installation, have the customer order the replacement diskettes.** If this is a **new installation** and the customer does not have the diskettes, order replacement diskettes by doing the following:

1. Write down the machine type and serial number.
2. Call **1-800-342-6672** (weekdays 9 a.m. to 9 p.m. eastern time).
3. Identify yourself as an IBM service representative or IBM authorized servicer.
4. For OS/2 Version 2.0, request diskette package P/N 41G3329. For OS/2 Version 2.00.1, request diskette package P/N 52G9973. The IBM telephone operator will supply the correct package part number for later versions of OS/2. (Supply the machine information and shipping address for either package.)

After you receive the OS/2 diskettes, refer to the pamphlet supplied with the diskettes for OS/2 installation instructions.

The PS/2 diagnostic tests are intended to test *only* IBM-marketed products. Products not marketed by IBM, prototype cards, or modified options can give false errors and invalid system responses.

Refer to the Hardware Maintenance Reference section of this manual for any related PS/2 reference information.

OS/2 Trap Errors

The following information will be helpful in diagnosing trap errors.

Error Code	Information
0000 0001	See note 7 (Application software error, contact the software vendor's support).
0002	See notes 4, 6, 8, and 9. Install CSDs, run CHKDSK. Replace the defective memory.
0003 0004 0005	See note 7 (Application software error, contact the software vendor's support).
0006 0007 0008	Check the memory. Run CHKDSK. Contact the application software vendor's support.
0009 000A 000B	See note 7 (Application software error, contact the software vendor's support).
000C	If "SYS1942" appears, contact the software vendor's support. If "Exception in Device..." appears, refer to note 4. Run CHKDSK. All other messages: Run CHKDSK and check the memory. If a 113 error appears, see ECA024.
000D	If "SYS1943 A Prog..." appears, contact the software vendor's support. If "Int Proc Error at 0220:3557" appears, set the Token Ring to 16K RAM window, install CSD's. If "double trap 000D" appears, install the latest CSDs. For all other messages or conditions, contact the software vendor's support.
000E	See note 7 (Application software error, contact the software vendor's support).
0010	Hardware or software error. Run diagnostics to check math coprocessor. If diagnostics find no problem, see note 7 (contact the software vendor's support).

Notes:

1. Memory intensive operating systems such as OS/2*, AIX*, or UNIX** based operating systems are capable of revealing highly intermittent errors not detected by diagnostics.
2. Highly intermittent errors might go undetected by diagnostics tests. If no error occurs during the test, multiple replacements of memory might be required to resolve the problem.

* Trademark of the IBM Corporation.

** Trademark of UNIX System Laboratories, Inc.

3. Install all software updates. This applies to applications and operating systems.
4. The enhanced memory adapter (FRU 34F2825) might experience Trap 0002 errors if it does not have diagonal resistors across U21-U24. See ECA042. (The enhanced memory adapter has been redesigned without resistors, so this note might not apply to the computer you are servicing.)
5. Intermittent errors can be caused by outside sources of static, noise, or power.
6. Trap 0002 can be caused by a memory or adapter failure. Read the message details. It might be the system board, system-board memory, or adapter.
7. Trap 000D errors are software errors. The customer should contact the software vendor for possible patches.
8. For 8570 systems, refer to ECA059, ECA051.
9. For 8580-AXX Models, see ECA051 for possible system board replacement to correct Trap 002, NMI, or DOS parity errors.

System Aid Diskette

A system aid diskette is now available for Trap 0002 errors. Dealers can download it from the Technical Advisors Bulletin Board as file "TRAP2LOG." The diskette will read NVRAM and indicate which of four possible sources caused the error. The four possible errors and their causes are listed below.

Error Code	Information
110	Usually a system-board memory error. If replacing the memory does not fix the problem, suspect the system board.
111	I/O Channel Check. Any adapter could cause this error, but usually a memory adapter is the cause.
112	Watchdog Timeout. Could be hardware or software. If replacing the system board does not fix the problem, suspect the software.
113	DMA Timeout. Usually a software error, but possibly a hardware failure (system board). If it is a 70-A21 with a 113 error, see ECA056, run CHKDSK. Contact the software vendor for more information. If it is any other system with a 113 error, refer to ECA023. Check the hardware.

PCMCIA Diagnostics (PS/2 E Model 33)

The PS/2 E Model 33 has a PCMCIA adapter that acts as a bus from the system board to the option adapters.

If the computer has a problem, carefully remove and reseal the riser card, any PC Cards, and the PCMCIA adapter. If, after reseating these boards, you get an 80XX error code, replace the PCMCIA adapter. For any other symptom, continue with the steps below.

If you suspect a problem with the PCMCIA adapter, do the following.

1. Power-off the computer.
2. Remove all option adapters from the four PCMCIA adapter slots.
3. If you have a PCMCIA wrap plug, insert it into slot one.
4. Insert the PS/2 E Type 9533 Advanced Diagnostics diskette into drive A.
5. Power-on the computer and follow the instructions on the screen.

If the PCMCIA adapter diagnostic tests find no problem, suspect a PC Card option adapter connected to the PCMCIA adapter. To test the PC Card, do the following.

1. Power-off the computer.
2. Insert the suspected PC Card into a rear slot in the PCMCIA adapter.
3. Insert the appropriate PC Card diagnostics diskette into drive A.
4. Power-on the computer and follow the instructions on the screen.

If the PC Card option adapter diagnostic tests find no problem, power-off the computer and insert the PC Card into a front slot. Power-on the computer. If the PC Card option adapter diagnostic tests still find no problem, replace the PCMCIA adapter.

If a PC Card option adapter fails in a front slot and it did not fail in a rear slot, replace the PCMCIA adapter.

If a PC Card fails in both a front and a rear slot, replace the PC Card.

Note: Before you replace a PC Card, be sure its application software and any required drivers are installed correctly on the computer.

PCMCIA Adapter Switch Settings

Switches on the PCMCIA adapter must be set as shown below.

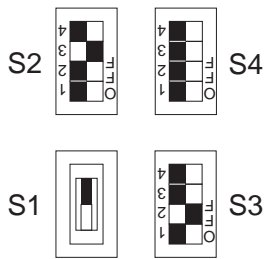

PCMCIA PC Card Lock Override

PC Cards can be locked in place for security purposes with the lock mechanism. Any of the four lock mechanisms can be unlocked manually. To unlock a locked mechanism, use a pen or pencil to press its lock solenoid in the direction of the arrow shown below. (Solenoids 1 and 3 are shown locked. Solenoids 2 and 4 are shown unlocked.)

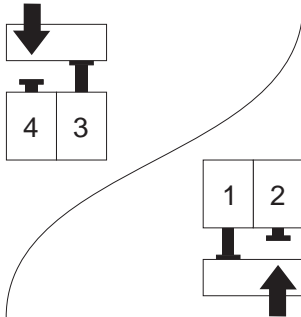

Printer Errors

1. Make sure the printer is properly connected and powered-on.
2. Run the printer self-test.

If the printer self-test does not run correctly, the problem is in the printer. Refer to the printer service manual.

If the printer self-test runs correctly, continue.

If the printer is attached to any parallel port, press the print screen key to print any screen text. If the printer prints the screen, the problem is software related. If the printer does not print the screen, continue. Install a wrap plug on the parallel port and run the advanced diagnostic tests to determine which FRU failed.

If the advanced diagnostic tests (with the wrap plug installed) do not detect a failure, replace the printer cable. If that does not correct the problem, do one of the following:

If the printer is attached to the parallel port on the system board, replace the system board.

If the printer is attached to the parallel port on an adapter, replace FRUs, in the following order, until the problem goes away:

1. Adapter
2. System board
3. Bus adapter (if installed)

Processor Board Installation (90, 95)

Improper installation can cause hard to diagnose failures, and simulate various error conditions. If the processor board fails, you might want to try reseating it.

Note: Never use the blue levers (on the board), to initially seat the board. The levers are intended to help you remove the board.

To install a processor board correctly:

1. Align the board with the *designated* slot (not an expansion slot).
2. Move the blue levers to the up (unlocked) position.
3. Firmly press the board into the slot until it snaps into place.
4. Simultaneously, move the blue levers to the down (locked) position.

Processor Boards with Diagnostic LEDs:

The 50-MHz Type 3 processor board in a 90/95 (submodel code 28 and 29), has two LEDs; one in position CR1, and one in CR2. During POST, CR1 should come on momentarily and CR2 should stay off. If the LEDs work any other way, suspect that the processor board is defective. Use the LEDs to help differentiate between a processor board or a system board failure. If you are instructed to replace one of the boards, and the problem still exists, replace the other board (also reinstall the first board).

Processor Boards without Diagnostic

LEDs: If the processor board does not have LEDs, you might not always be able to differentiate between processor board and system board failures. If you are instructed to replace one of the boards, and the problem still exists, replace the other board (also reinstall the first board).

Processor Upgrade (Models 50/50Z/60 - 486SLC2) Switch Settings

Use these switch settings for the Models 50, 50Z, and 60 only.



Processor Upgrade (Models 70/80 - 486DX33) Switch Settings

Use these switch settings for the Model 70 and Model 80 only.

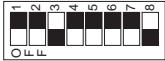

Processor Upgrade (Model 70/80 - 486DX33) FRU Isolation

Note

Before running diagnostic tests, check that the processor upgrade card is fully seated in the system board and that the 80486 processor is fully seated in the upgrade card.

1. Power-off the computer.
2. Insert the 70/80 Reference Diskette in drive A.
3. Power-on the computer.
4. Follow the instructions on the screen to test the processor upgrade. If the tests cannot find a problem, replace the processor upgrade with an 80386 processor from a new system board (or the original 80386 processor, if available). If the failure does not occur again, replace the processor upgrade with a new one. If the failure does occur again, replace the system board, and reinstall the original processor upgrade. If the failure occurs again after replacing the system board, replace the processor upgrade also.

Note

Use the 80386 processor only to diagnose the problem. If it came from the customer, be sure you return it to them. If the processor came from a new system board that you brought with you, and the system board is not the problem, reinstall the processor on the new system board before you return it to stock. If the system board is the problem, return the 80386 processor with the bad system board.

Processor (Px) Label Cross-reference

Upgraded systems should have a Px label placed on the front cover of the system unit (to the right of the serial number) at the time the system was upgraded. The following matrix cross-references the Px label, a description of the upgrade, and the upgrade FRU number.

Px Label	Description	FRU Number
P2	Models 50, 50Z 486SLC2 System Board	61G3502
P1	Model 50Z 486SLC2 Processor Upgrade Card	71G2633
P1	Models 50, 60 486SLC2 Processor Upgrade Card	71G2625
P2	Model 55 486SLC2 System Board	71G2602
P3	Models 60, 65, and 80 486DLC2 System Board	71G2610
P2	Models 60, 65, and 80 486DX2 System Board	71G2643
P1	Model 70 486DX33 Processor Upgrade Card	92F0436
P3	Model 70 486DLC2 System Board	71G2606
P2	Model 70 486DX33 System Board	71G2641
P1	Model 80 486DX33 Processor Upgrade Card	92F0437

Power Supply Voltage Check

If the power-on indicator is not on, and if the power-supply fan is not running, check the power cord for proper installation and continuity.

Note: Verify that the voltage-select switch (if applicable) is set for the correct voltage.

If the power cord is OK, either the power supply is defective or a defective device is causing the power supply to shut off. Check the power supply voltages.

If the voltages are incorrect, replace the power supply. If the voltages are correct, and the Symptom-to-FRU index does not solve the problem, go to "Undetermined Problems" on page 183.

Models 25, 25 SX, 25-286

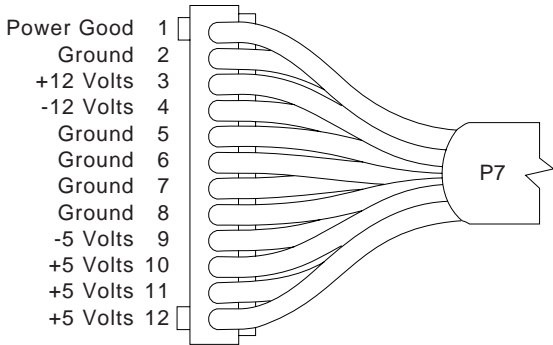

Models 30, 30-286

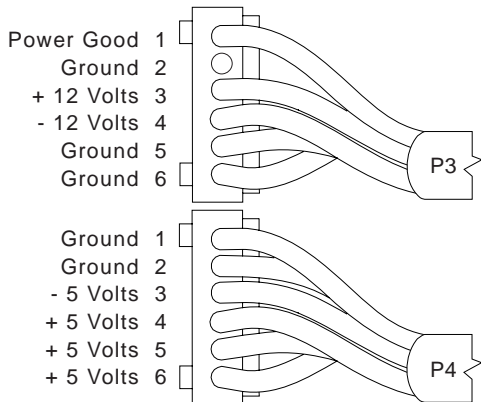

Model 33

If the power-on indicator is not on, check the power cord for proper installation and continuity. (If the power-on indicator is not on, but the computer is functioning normally, replace the power switch/speaker assembly.)

1. Check for continuity between pins 4 and 6 (switch) on P2.
2. If the switch is OK, *short* pin 4 to pin 6 on P2 and check the power supply voltages.

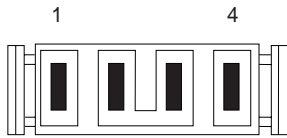

P1

+Lead Pin	-Lead Pin	V dc Minimum	V dc Maximum
1, 2 (+5 volts)	Ground	+3.75	+6.25
3, 4 (Ground)	Ground		

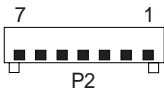

P2

+Lead Pin	-Lead Pin	V dc Minimum	V dc Maximum
1, 2 (+12.0 volts)	Ground	+ 9.0	+15.0
3 (Power Good)	Ground	+ 2.4	+ 5.25
4 (On/Off Signal)	Ground		+ 1.0
5 (-12.0 volts)	Ground	- 9.0	- 15.0
6 (Ground)	Ground		
7 (-5 volts)	Ground	-4.75	- 5.5



P3

+Lead Pin	-Lead Pin	V dc Minimum	V dc Maximum
1 (Ground)	Ground		
2,3 (+5 volts)	Ground	+3.75	+6.25

Models 35, 40, 56, 57, 76, 77

1. Check for continuity between pins 4 and 6 (switch) on P2.
2. If the switch is OK, *short* pin 4 to pin 6 on P2 and check the power supply voltages.

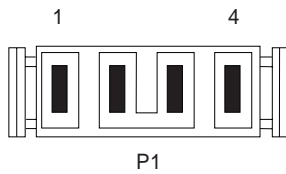

-Lead Pin	+Lead Pin	V dc Minimum	V dc Maximum
4	1	+3.75	+6.25

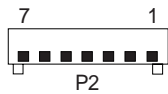

-Lead Pin	+Lead Pin	V dc Minimum	V dc Maximum
6	1	+ 9.0	+15.0
3	Power Good		
4	On/Off Signal		
6	5	- 9.0	- 15.0
6	Ground		
6	7	-4.75	- 5.5



-Lead Pin	+Lead Pin	V dc Minimum	V dc Maximum
2	1	+ 9.0	+15.0
2, 3	Ground		
3	4	+3.75	+6.25

Models 50, 70

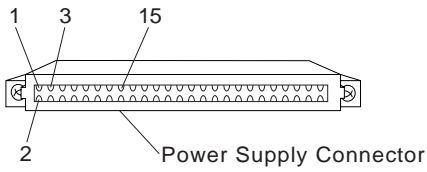

-Lead Pin	+Lead Pin	V dc Minimum	V dc Maximum
2	1	- 9.0	-15.0
2	3	+15.0	+15.0
2	15	+ 6.2	+ 6.2

Model 55, PS/2 9553-xBx

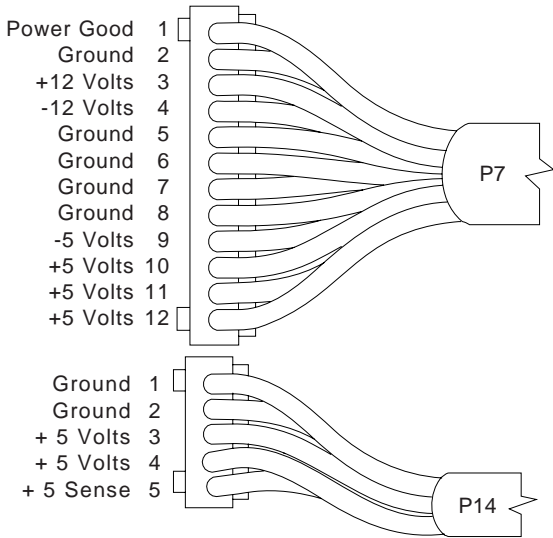

Models 60, 65, 80

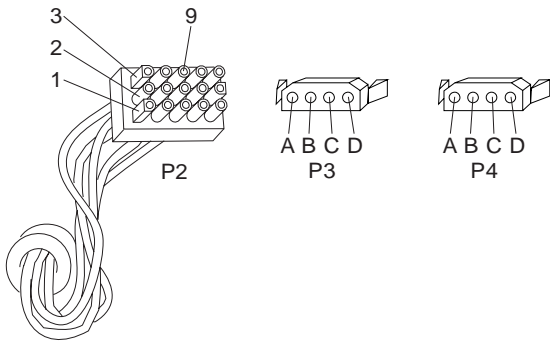

-Lead Pin	+Lead Pin	V dc Minimum	V dc Maximum
2	9	-9.0	-15.0
2	3	+9.0	+15.0
2	1	+3.7	+ 6.2
B	D	+3.7	+ 6.2
C	A	+9.0	+15.0

Model 90

Check the voltages with connectors P1 and P2 plugged into the system board.

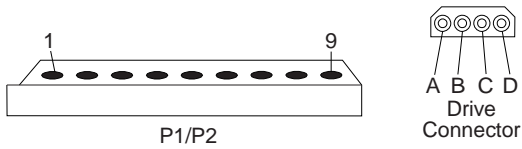

-Lead Pin	+Lead Pin	V dc Minimum	V dc Maximum
1 (P1)	2-7 (P1)	+ 4.8	+ 5.25
1 (P1)	8,9 (P1)	+11.5	+12.6
2 (P2)	1 (P2)	-11.5	-12.6
B	D	+ 4.8	+ 5.25
B	A	+11.5	+12.6

There are two systems fans: one in the power supply, and a second fan on the base. If the power supply fan does not work, replace the power supply. If the second fan does not work, replace it.

PC Server (8640)

Note: Verify that the voltage-select switch (if applicable) is set for the correct voltage.

If the power-on indicator is not on, and if the power-supply fan is not running, check the power cord for proper installation and continuity.

If the power cord is OK, either the power supply is defective or a defective device is causing the power supply to shut off. Check the power supply voltages.

If the voltages are incorrect, replace the power supply. If the voltages are correct, and the Symptom-to-FRU index does not solve the problem, go to "Undetermined Problems" on page 183.

Connector P1



-Lead Pin	+Lead Pin	V dc Minimum	V dc Maximum
5, 6	1	Power Good	
5, 6	2	+4.8V	+5.25V
5, 6	3	+11.52V	+12.60V
5, 6	4	-10.8V	-13.2V

Connector P2

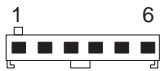

-Lead Pin	+Lead Pin	V dc Minimum	V dc Maximum
1, 2	3	-4.5V	-5.5V
1, 2	4	+4.8V	+5.25V
1, 2	5	+4.8V	+5.25V
1, 2	6	+4.8V	+5.25V

Continued on the next page.

PC Server (8640) continued

Connector P3

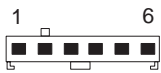

-Lead Pin	+Lead Pin	V dc Minimum	V dc Maximum
4, 5, 6	1, 2, 3	+4.8V	+5.25V

Connectors P4 and P6

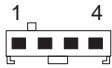

-Lead Pin	+Lead Pin	V dc Minimum	V dc Maximum
2, 3	1	+4.8V	+5.25V
2, 3	4	+11.52V	+12.6V

Connectors P5, P7, and P8



-Lead Pin	+Lead Pin	V dc Minimum	V dc Maximum
2, 3	1	+11.52V	+12.6V
2, 3	4	+4.8V	+5.25V

PC Server 500 (Type 86XX) Power

Supplies: The Type 86XX computers are shipped with a primary power supply. An additional or optional power supply can be added to the computer. Connectors are used to transfer the primary power supply voltages and signals from the primary power supply to the optional power supply. The following illustrations show how the two power supplies are connected.

Caution

When replacing the primary power supply cover plate, rotate the plate 180°. (This will leave an opening for the primary power supply connector cable that connects to the optional power supply.) Failure to do so will cause the power supply connector cable to be crimped when the plate is replaced.

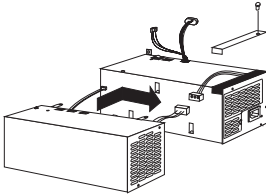

Note

Tabs are located on the side of each power supply to secure them together.

Primary Power Supply Voltages

If the voltages are correct, and the power supply fan runs, the power supply is OK.

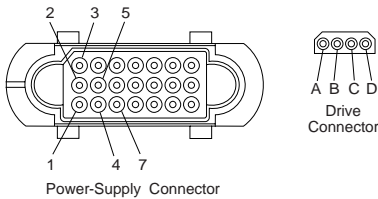

-Lead Pin	+Lead Pin	V dc Minimum	V dc Maximum
5	3	+3.7	+ 6.2
5	4	+9.0	+15.0
5	7	-9.0	-15.0
B	D	+3.7	+ 6.2
B	A	+9.0	+15.0

Connectors P11, P12, and P13



-Lead Pin	+Lead Pin	V dc Minimum	V dc Maximum
2	1	+11.5	+12.6

Optional Power Supply Drive Connector Voltages

If the voltages are correct, and the power supply fan runs, the power supply is OK.

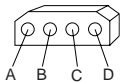

-Lead Pin	+Lead Pin	V dc Minimum	V dc Maximum
B	D	+ 3.7	+ 6.2
B	A	+ 9.0	+15.0

If the power supply shuts down, or *appears* to fail at power-on, you might have one of the following problems:

- Too many devices are set to start instantly. See "Setting the Motor-Start Jumper" on page 414.
- There are too many large-capacity devices installed. The nominal operating current of the devices installed collectively exceeds the available current of the power supply. See the "Personal System/2 Installation Planning" guide (form number G41G-2927) for more information.

Caution

Unplug the power cord and wait two minutes before checking voltages to give the power supply capacitors time to discharge.

On some models, there is an access-cover fan (to cool the processor). If that fan does not work, you have one of the following problems:

- Verify the voltage-select switch (if applicable) is set for the correct voltage.
- No power to the fan: 12 V dc (± 1.4 V dc) required at the two fan cable pins on the base.
- Defective J28 cable (check cable continuity)
- Defective fan. (To test the fan, use a two-wire jumper to connect the fan terminals to the cable pins on the base.)
- Defective system board.

Server 85, PS/2 9585-xKx, PS/2 9585-xNx, Model 95, and 3511:

Some power supplies have a built-in test switch and LED on the side of the power supply (there is no need to check voltages). On those power supplies, disconnect the power supply from the system board, and remove all cables except the power cord. Power-on the power supply and push the test button. If the LED lights up, and the power supply fan runs, the power supply is OK.

On all *other* power supplies, short pin 1 to pin 2 and read the voltages on the other pins. If the voltages are correct, and the power supply fan runs, the power supply is OK.

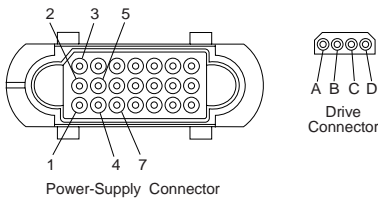

-Lead Pin	+Lead Pin	V dc Minimum	V dc Maximum
5	3	+3.7	+ 6.2
5	4	+9.0	+15.0
5	7	-9.0	-15.0
B	D	+3.7	+ 6.2
B	A	+9.0	+15.0

If the power supply shuts down, or *appears* to fail at power-on, you might have one of the following problems:

- Too many devices are set to start instantly. See "Setting the Motor-Start Jumper" on page 414.
- There are too many large-capacity devices installed. The nominal operating current of the devices installed collectively exceeds the available current of the power supply. See the "Personal System/2 Installation Planning" guide (form number G41G-2927) for more information.

Caution

On Model 95 unplug the power cord and wait two minutes before checking voltages to give the power supply capacitors time to discharge.

On a Model 95, there is an access-cover fan (to cool the processor). If that fan does not work, you have one of the following problems:

- No power to the fan: 12 V dc (± 1.4 V dc) required at the two fan cable pins on the base.
- Defective J28 cable (check cable continuity)

Defective fan. (To test the fan, use a two-wire jumper to connect the fan terminals to the cable pins on the base.)

Defective system board.

Model 3510

-Lead Pin	+Lead Pin	V dc Minimum	V dc Maximum
B	D	+3.7	+ 6.2
C	A	+9.0	+15.0

Model 3532

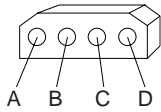

-Lead Pin	+Lead Pin	V dc Minimum	V dc Maximum
B	D	+ 4.75	+ 5.25
C	A	+11.40	+12.60

OBI DASD Hot Swap Storage Expansion Enclosure

If the power-on indicator is not on, and if the power-supply fan is not running, check the power cord for proper installation and continuity.

Note: Verify that the voltage-select switch (if applicable) is set for the correct voltage.

If the power cord is OK, either the power supply is defective or a defective device is causing the power supply to shut off. Check the power supply voltages.

If the voltages are incorrect, replace the power supply. If the voltages are correct, and the Symptom-to-FRU index does not solve the problem, go to "Undetermined Problems" on page 183.

Connector P3

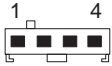

-Lead Pin	+Lead Pin	V dc Minimum	V dc Maximum
2, 3	4	+12.5V	+11.4
2, 3	1	+4.8V	+5.3V

Connector P4



-Lead Pin	+Lead Pin	V dc Minimum	V dc Maximum
2, 3	1	+12.5V	+11.4
2, 3	4	+4.8V	+5.3V

Connectors P5, P5, P7, and P8



-Lead Pin	+Lead Pin	V dc Minimum	V dc Maximum
2, 3	1	+12.5V	+11.4
2, 3	4	+4.8V	+5.3V

Real-Time Clock Problems

The software time-of-day clock (real-time clock) will not provide precise time under all circumstances. The clock is interrupt driven. The accuracy of the clock varies with the interrupt activity. Most likely, time variations are a result of multiple interrupts (over a long period of time), rather than a hardware failure. In circumstances where precise time is required, an alternate time keeping device should be used.

Check the system date/time using the Reference Diskette Set Features menu. If the date/time is accurate, the problem is with the software.

Note: Some LAN software might update the time on the workstation using the server time.

Remote Power-on Jumper (95)

Note: Not on all 95 systems.

The jumper (labeled JMP4) is on the system board near the serial port. Set the jumper to position for direct-connect and leased-line modems. Set the jumper to position 1 (default) for all other modems. For more information see "Power-on Features" on page 380.

Running Automatic Configuration

Running Automatic Configuration might alter customized configuration settings. Note the current settings using **View configuration**. If the configuration was customized, save it, then restore it to the customized settings after service is complete.

ServerGuide CDs (Type 86XX)

SCSI Controller on the System Board	180
SCSI Device Default Settings	180
SCSI Diagnostic Tests	181
SCSI ID (Using to Help Isolate Failures)	181
Servicing LAN Stations (Workstations)	181
Software/Hardware Mismatch Problems	181
Undetermined Problems	183
VPD Codes Information	183
System Board Locations	185
Parts Catalog	222

Using the CD-ROM Drive and ServerGuide: If you are installing an operating system, it is important that you read and understand the following information:

The ServerGuide CD contains SCSI (small computer system interface) and SVGA (super video graphics array) device drivers that will be automatically installed if you install one of the operating systems that are available in the CD package.

If you choose not to install one of the operating systems that are available on the CDs, you still must use the ServerGuide CD to create diskettes containing the SCSI device drivers and SVGA video device drivers. The device-driver diskettes that you create will contain README files that explain how to install these drivers and complete the installation procedure.

A RAID (redundant array of inexpensive disks) controller diskette must be created, from the ServerGuide CD, for all disk-array models.

Note

Locate the ServerGuide CD. You will need the main ServerGuide CD shortly after you power-on the server.

1. Power-on all external devices, then power-on the server.
2. After the POST completes, press the CD-ROM tray-release button. The CD-ROM tray extends out approximately one inch from the server. Pull the tray straight out until it stops.

Note

If the CD-ROM tray does not extend out, insert the end of a paper clip into the manual tray-release opening.

3. With the label information facing right, center and place the main ServerGuide CD on the hub.
4. Push the CD-ROM tray back into the server.
5. Press **F1** to restart the server. If the server does not restart, press **Ctrl+Alt+Del**.
6. If the server is a disk-array model, or if you are installing one of the operating systems available in the ServerGuide package, select **Start Here** from the Main Menu and follow the instructions on the screen. If you are not installing an operating system from ServerGuide, go to "Not Installing an Operating System from ServerGuide."

Not Installing an Operating System from

ServerGuide: If you are *not* installing one of the operating systems available in the CD package, use the

following procedure to create the diskettes that you need to complete the installation procedure:

1. Get the 1MB and 2MB, 3.5-inch diskettes that you will use to create diskettes from the diskette images on the main ServerGuide CD.
2. Select **Utility Programs**.
3. Select **Diskette Factory**.
4. Select **IBM SVGA Support Diskettes**, and follow the instructions on the screen to create both video device drivers diskettes.
5. The remaining steps depend on whether or not the server is a disk-array model.

If the server is *not* a disk-array model, continue with Diskette Factory and select **IBM SCSI-2 Fast/Wide Support Diskette**. Follow the instructions on the screen to create a SCSI-2 device drivers diskette. When you are finished, go to "Non-Disk-Array Models Only."

If the server is a disk-array model, continue with "Disk-Array Models Only."

Disk-Array Models Only: Continue with Diskette Factory:

1. Select **IBM SCSI-2 Fast/Wide Streaming-RAID Adapter/A Option Diskette**. Follow the instructions on the screen and create the IBM RAID controller diskette.
2. Press the CD-ROM tray-release button to release the tray from the server. Remove the CD from the CD-ROM tray, and push the tray back into the server.
3. Go to "Configuring the Disk Array (Type 86XX)" on page 154 and become familiar with that information; then, do the following:
 - a. Follow the instructions to configure the disk array (see "Starting the RAID Configuration Program" on page 157).
 - b. Follow the instructions to back up the disk-array configuration (see "Backing Up Your Disk-Array Configuration" on page 170).
 - c. After you back up the disk array, follow the instructions that came with the operating system and install the operating system.

Non-Disk-Array Models Only: If the server is *not* a disk-array model, do the following:

1. Press the CD-ROM tray-release button to release the tray from the server.
2. Remove the CD from the tray, and push the tray back into the server.
3. Follow the instructions that came with the operating system and install the operating system.

Configuring the Disk Array (Type 86XX): The following information applies only to disk array models. Use this information to perform the tasks necessary to configure, add, change, or delete one or more disk arrays.

If you did not create an IBM RAID controller diskette, go to "Using the CD-ROM Drive and ServerGuide" on page 152.

Familiarize yourself with the information contained in this manual and the RAID (redundant array of inexpensive disks) information in the *User's Reference* shipped with the server.

Verify the disk-array configuration. The disk-array model comes configured as one logical drive.

- To view the disk-array configuration, go to "Viewing the RAID Configuration" on page 159 and select **View Configuration** from the Main Menu.
- To create a disk array, go to "Creating a Disk Array" on page 161.

Backup the disk-array configuration. See "Backing Up Your Disk-Array Configuration" on page 170.

After you configure the disk array, you can complete setup by installing an operating system (from the ServerGuide compact disc that was shipped with the server or from the diskettes that came with the operating system). To install an operating system from the ServerGuide CD, go to "Using the CD-ROM Drive and ServerGuide" on page 152.

RAID Technology: RAID is the technology of grouping several hard disk drives in a server into an *array* that can be defined as a single logical drive. This *logical* drive then appears to the operating system as a single *physical* drive. This grouping technique greatly enhances logical-drive capacity and performance. In addition, if one of the hard-disk drives fails (becomes defective the server continues to run, with no operator intervention required, at reduced performance. The defective drive can be replaced without powering off the server (*hot-swap*). For more information about hot-swappable hard disk drives, see "Installing Internal Drives (Type 86XX)" on page 176.

Hard Disk Drive Capacities: With a server, it is important to understand the implications of hard disk drive capacities and how they influence the way you create disk arrays.

Drives in the disk array can be of different capacities. For example, if the model came with two 1GB hard disk drives and you install a 2GB hard disk drive to create a RAID 5 disk array, the total capacity of the array is 3GB instead of 4GB. Therefore, when creating arrays it is wise to add drives of equal capacity.

Additional Storage Capacity: When you add hard disk drives to the server, you must configure a new disk array before the drives can be used. You can either reconfigure the existing disk array to include the capacity offered with the added drives, or group the added drives into their own array (see “Adding Drives to Create an Additional Array” on page 162). You also can create an array with only one drive.

The RAID Configuration Program Screens: When you configure the disk array, or even just view its configuration, you will be using the IBM RAID configuration program on the IBM SCSI-2 Fast/Wide Streaming-RAID Adapter/A Option Diskette (also called the IBM RAID controller diskette). The following figure is a compilation of many of the IBM RAID Controller Disk Array Configuration (also called the IBM RAID configuration program) screens. The list below the figure gives explanations of the numbered areas of the figure.

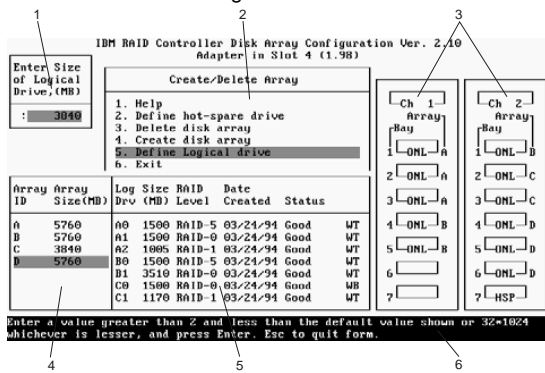

1. This pop-up allows you to select the RAID level you want to assign to the logical drive you are defining, and it allows you to select the logical drive size. You can enter the size, in megabytes, or you can accept the default value shown.
When you need to confirm an action, the Confirm pop-up appears in this area.
2. You can select any of the choices that appear on the menus.
3. The Bay/Array selection list shows each bay in the server (for each channel) numbered 1 through 7. The abbreviation in the bay indicates the status of the drive installed in the bay. Selections are made from this list to determine which bays (hard disk drives) are in the arrays. The letter to the right of the bay, identifies the array in which the hard disk drive in that bay is grouped.

Note

The Channel/Bay/Array area on the screen does not reflect the physical configuration of the server. The hard disk drives are installed in horizontal banks of bays (in banks C, D, and E there are 6 bays, numbered 1 through 6 from left to right). See "Installing Internal Drives (Type 86XX)" on page 176 to see the physical location of the hard disk drives.

4. The Array list shows you the array ID and the size (in megabytes) of the array.

Note

The capacity (size) is shown in binary equivalent.

When a drive is being rebuilt, this area, along with the Logical Drive list area, shows the progression of the rebuilding process.

5. The Logical Drive list identifies the logical drive (for example, A1), the size of the logical drive, the RAID level assigned to the logical drive, the date it was created, and the write policy.

The status of the logical drive also is shown. **Good** means that all is well with the drive; **Critical** means that you must replace the drive or do a rebuild operation. (You will have received a message telling you the drive is in a **Critical** state.) **Offline** means that the logical drive is unrecoverable; the data in that drive is lost.

When a drive is being rebuilt, this area, along with the Array list area, shows the progression of the rebuilding process.

Note

The capacity (size) is shown in binary equivalent.

During an initialization process, the Write Policy area displays the percent initialized; during a synchronization process, it displays the percent synchronized.

6. The information area tells you the action you can perform on this screen or pop-up.

Starting the RAID Configuration Program: You can run the IBM RAID configuration program from diskette or from the ServerGuide CD. It will be automatically invoked from the ServerGuide CD if the disk array has never been partitioned and if there is no user data present. However, updated configuration information must be written to diskette. If you have not yet created the IBM SCSI-2 Fast/Wide Streaming-RAID Adapter/A Option Diskette (RAID controller diskette), go to "Using the CD-ROM Drive and ServerGuide" on page 152.

To start the RAID configuration program.

1. Insert the IBM RAID controller diskette into the primary drive and power-on the server.
If the server is already on, press **Ctrl+Alt+Del**.
If you have more than one RAID adapter, you will get an adapter selection screen. Otherwise, the Main Menu appears.

RAID Program Keys

Key	Program Response
F1	Selects Help from any menu
Esc	Return to the previous screen or to the previous work area of a screen
Up () and Down () Arrows	Highlights the item to be selected
Enter	Selects the highlighted item

Main Menu Selections

Note

Whenever you make changes to the disk-array configuration and select **Exit**, the Confirm pop-up window will appear. You must select **Yes** to save and activate the changes.

Selection	Program Response
Help	Provides additional information
View configuration:	Displays the existing disk array configuration
Create/delete array:	Selects the drives, defines a hot-spare drive for an array you want to create, or to deletes an existing array. This selection also has choices for defining a logical drive and formatting a drive.

Selection	Program Response
Initialize/synchronize array:	<p>Select this choice after creating an array to:</p> <p>Set the drive to a predetermined value. For proper operation of RAID levels 1 and 5.</p> <p>Note: Any data existing on the drive is overwritten with zeros, and the corresponding parity information is initialized to the correct value.</p> <p>Initialize more than one logical drive at a time. Interrupt the initialization process at any time by pressing Esc. Restart the initialization process by pressing Enter End the process by pressing Esc again.</p>
Synchronize logical drive	<p>Recomputes and rewrites the parity data on the drive. You can select this choice to recompute parity data for RAID levels 1 and 5. This selection does not alter data on the drive. The synchronization process can be done on multiple logical drives.</p>
Rebuild device:	<p>Rebuilds logical drives. The rebuild operation is supported only for RAID levels 1 and 5.</p>
Advanced functions:	<p>Changes the write policy (the way data is written to the drive), to save your configuration information to a diskette, restores it from a diskette, or changes RAID parameters. This choice also allows you to do a low-level format.</p>
Drive information:	<p>Displays information about the SCSI devices (hard disk, CD-ROM, tape, and so on) connected to the RAID adapter.</p>
Exit:	<p>Leaves the Main Menu.</p>

Viewing the RAID Configuration: Before creating or changing a disk array, you can look at the current configuration by selecting **View Configuration** from the Main Menu of the RAID configuration program.

To view the disk-array configuration:

1. Start the RAID configuration program. See “Starting the RAID Configuration Program” on page 157.
2. Select **View configuration**. The current disk-array configuration information appears on the screen.
3. Press **Enter** to see the stripe order in the Bays Occupied (Ch:Bay) field.
4. Press any key to continue.
5. Press **Esc** to return to the Main Menu.

Performing Common Tasks: The Create/Delete Array menu of the RAID configuration program contains the more common tasks for configuring disk arrays. Procedures to complete these tasks are contained in this section as follows:

- “Defining a Hot-Spare Drive”
- “Deleting a Disk Array” on page 160
- “Creating a Disk Array” on page 161
- “Defining Logical Drives” on page 162

Defining a Hot-Spare Drive: To define a drive as a hot-spare drive:

1. Start the RAID configuration program. See “Starting the RAID Configuration Program” on page 157.
2. Select **Create/delete array** from the Main Menu. The Create/Delete Array screen appears.
3. Select **Define hot-spare drive**. The cursor will become active in the Bay/Array selection list.

Note

Only SCSI hard disk drives are shown as RDY, ONL, DDD, OFL, or HSP state. SCSI tape and CD-ROM drives are not shown. They appear when you select drive information. Refer to “Bay/Array Selection List” on page 165 for the drive status meanings.

- The numbers shown on the left are the bay IDs. See “Installing Internal Drives (Type 86XX)” on page 176 for an explanation of the bay IDs.
4. Use the Up Arrow () key or the Down Arrow () key to highlight the **RDY** (ready) drive you want to define as the hot spare; then press **Enter**. The **RDY** changes to **HSP** (hot spare). You can press **Enter** again to toggle between **HSP** and **RDY**.
 5. Press **Esc** when you have finished. The cursor will become active in the Create/Delete Array menu.
 6. If you want to create a disk array, go to “Creating a Disk Array” on page 161.

7. If you are finished:
 - a. Select **Exit** or press **Esc**. A pop-up window will appear asking you to confirm your change.

Note

The changes you make are not saved until you confirm them by selecting **Yes** in the Confirm pop-up window.

- b. Select **No** if you do not want the drive you selected to be a hot spare; select **Yes** to define it as a hot-spare drive.
- c. Back up the disk-array configuration information to diskette. Refer to "Backing Up Your Disk-Array Configuration" on page 170 for instructions.

Deleting a Disk Array: The last array created must be the first deleted.

Warning

All the data and programs in the array are lost during this procedure. Before proceeding, back up any data and programs that you want to save.

To delete a disk array:

1. Start the RAID configuration program. See "Starting the RAID Configuration Program" on page 157.
2. Select **Create/delete array** from the Main Menu.
3. Select **Delete disk array** from the Create/Delete Array menu. The cursor will be active in the Array list.
4. Review the Date Created column in the Logical Drive list; then press the Up Arrow () key or the Down Arrow () key to highlight the most recently defined array.
5. Press **Del**. The Confirm pop-up window appears.
6. If you do not want to delete the array, select **No**. To delete the array, select **Yes**.

Note

To use hard disks from the existing array when creating a new array, you must confirm the deletion of the existing array.

If a defective drive is still in a bay, the status shows a blank bay, as though there is no drive in that bay. When you replace the drive, the status will show **RDY** after you reconfigure and select **Yes** in the Confirm pop-up window.

Note

In some operating systems, deleting an array and associated logical drives might change the drive letters assigned to the existing drives.

Creating a Disk Array: To create a disk array:

1. Start the RAID configuration program. See "Starting the RAID Configuration Program" on page 157.

Note

To create an array using hard disks in an existing array, refer to "Redefining Space in an Array" on page 169.

2. Select **Create/delete array** from the Main Menu.
3. Select **Create disk array** from the Create/Delete Array menu.

The cursor will be active in the Bay/Array selection list.

Important

In the following step, when you press Enter to select a drive for an array, you cannot deselect it by pressing Enter again, as you can with the hot-spare selection process. Carefully determine which drives you want to include in the array before beginning the selection process.

If you change your mind after selecting the drives for an array, you can delete the array (by selecting **Delete disk array** from the Create/Delete Array menu) and begin again.

4. Select each drive you want in the array by using the Up Arrow () key or the Down Arrow () key to highlight the drive and then pressing **Enter**. As you select each drive, the status will change from **RDY** (Ready) to **ONL** (Online).
5. When you have selected all the drives you want to include in the array, press **Esc**. The cursor will become active in the menu.
6. If you have drives you did not use in this array and you want to create another array, you can do one of the following:
 - Define the logical drive or drives for this array; then create another array and its logical drives. See "Defining Logical Drives" on page 162.
 - Create another array now by repeating steps 2 through 5 in this procedure; then define logical drives for both arrays.

Note

You must define at least one logical drive for each created array before you can exit the configuration program.

Continue with "Defining Logical Drives."

Adding Drives to Create an Additional Array: To add storage capacity to your server without disturbing existing data:

1. Install the additional hard disk drive or drives. (See "Installing Internal Drives (Type 86XX)" on page 176.)
2. Start the RAID configuration program. See "Starting the RAID Configuration Program" on page 157.
3. Create a new disk array and define logical drives (see "Creating a Disk Array" on page 161 for additional information).

Defining Logical Drives: After you have created an array, you must define a logical drive. (You cannot leave the RAID configuration program until you define the logical drives for any created arrays.)

To define a logical drive:

1. Select **Define Logical drive** from the Create/Delete Array menu. The Create/Delete Array menu screen appears; the cursor is active in the Array list.
2. Use the Up Arrow () key or the Down Arrow () key to highlight the array you want to define; then press **Enter**. The Select RAID Level pop-up window appears, and the cursor is active in the window.

Note

The system automatically assigns RAID level 0 to any logical drives defined in an array containing only one hard disk drive. When this is the case, the Select RAID Level pop-up window will not appear.

If you have only two hard disk drives in the array, the Select RAID Level pop-up window appears, but RAID level 5 is not selectable because you need at least three hard disk drives in an array to assign RAID level 5 to one of the logical drives. You can define more than one logical drive for your array. The only restriction is that the maximum number of logical drives you can define is eight.

3. Use the Up Arrow () key or the Down Arrow () key to highlight the RAID level you want to assign to these logical drives, then press **Enter**.

Note

Because the level you assign can influence the space needed for the drive, you must assign a RAID level before you enter the size of the logical drive.

The Logical Drive list shows you the logical drive ID, the size of each logical drive, the RAID level you assigned to that logical drive, and the date that the logical drive was created.

The status of the logical drive also is shown. **Good** means that all is well with the drive. **Critical** means that you must replace the hard disk drive or do a rebuild operation. (You will have received a message telling you what has happened to the drive.) **Offline** means that the logical drive is unrecoverable; the data on that drive is lost.

The Logical Drive Size pop-up window shows the space in this array that is available for logical drives.

4. Type the size, in megabytes, that you want for the logical drive; then press **Enter**. A pop-up window appears asking you to confirm your action.

Information about the new logical drive appears in the Logical Drive list.

Note

The size appearing in the Logical Drive list might be different from the size you typed because it appears in binary equivalent.

The size of a logical drive is determined by a number of factors, but basically the size must be divisible by the number of drives in the array.

Consider the following examples:

Example 1:

There are three 1GB drives in the array. You assign RAID level 0 (which uses all the drives in the array with no parity storage), and type "1000MB." The "Size (MB)" will be 999, which is the number closest to and lower than 1000 that is divisible by 3.

Example 2:

There are three 1GB drives in the array, and you assign RAID level 5. Data is striped across all three drives in the array, but the space equivalent to that of one drive is used for redundant storage. Therefore, if you type "1000MB," the "Size (MB)" remains 1000 because it is divisible by 2 (drives), which is the space available for data.

If you do not use the entire array for this logical drive, you can create another by assigning either the same

or a different RAID level for an additional logical drive. You can have as many as eight logical drives among four disk arrays.

5. To return to the Create/Delete Array menu, press **Esc**. To define more logical drives, repeat steps 1 through 5 of this procedure.
6. To leave this screen, select **Exit** or press **Esc**. A pop-up window appears asking you to confirm your action.
7. To save your changes, select **Yes**. To maintain the disk-array configuration that was in place before you made changes, select **No**.
8. If you are using RAID level 1 or RAID level 5, *you must select Initialize logical drive for proper operation*. This sets the drive to a predetermined state. Any data existing on the drive is overwritten with zeros, and corresponding parity is initialized to the correct value.
 - a. Select **Initialize/synchronize array** from the Main Menu; then select **Initialize logical drive**.
 - b. Select the logical drives you want to initialize from the Logical Drive list by pressing the Spacebar (the selected drives will appear highlighted). To start the initialization, press **Enter**. A pop-up window appears asking you to confirm your action.

Warning

If you select **Yes** in the Confirm pop-up window, information in the logical drive will be overwritten with zeros.

- c. Select **Yes** to confirm that you want to initialize this logical drive.

The initialization process begins, and you can see its progress in the **Pct. Int.** (Percent Initialized) column of the Logical Drive list.
 - d. To stop the initialization at any time, press **Esc**. Then press **Esc** again to return to the menu, or press **Enter** to continue initializing the drive.
9. To back up the disk-array configuration to diskette, you will need a 3.5-inch formatted diskette. To back up the disk-array configuration:
 - a. Select **Advanced functions** from the Main Menu.
 - b. Select **Backup config. to diskette**.

Follow the instructions on the screen. A pop-up window shows the default file name of CONFIG. You can change the file name by typing over the default. The Backup program will assign a file-name extension of *.dmc*.

Drive Maintenance: The following section provides information about status indicators for logical and hard disk drives, and the results of a hard disk drive failure. It also contains procedures for replacing defective drives and for redefining the space in an array by replacing logical drives.

Obtaining Drive Status: To see the ID, capacity, and other information about each of the hard disk drives attached to the RAID adapter:

1. Start the RAID configuration program. See "Starting the RAID Configuration Program" on page 157.
2. Select **Drive information**.
3. Use the Up Arrow () key or the Down Arrow () key to highlight each of the drives shown in the Bay/Array selection list. As a drive is highlighted, the information for that drive is shown at the bottom of the screen.
4. Press **Esc** to return to the Main Menu.

Note

The status of the hard disk drive determines the status of the logical drives in the array in which the hard disk is grouped.

Bay/Array Selection List: The status of the drives in the Bay/Array selection list is defined as follows:

Status	Meaning
CDR	CD-ROM drive installed.
DDD	Defective. The drive is an online or hot-spare drive that does not respond to commands. (If a RDY drive is defective or powered down, it shows an empty bay (a blank status), not a DDD status).
FMT	Format. The drive is being reformatted.
HSP	Hot spare. The drive will replace a similar drive that becomes defective in real time. At that time, its status changes to ONL , and its array association is displayed.
OFL	Offline. The drive is a good drive that has replaced a defective drive in a RAID level 1 or level 5 array. It is associated with an array, but does not contain any valid data. The drive state remains OFL during the rebuild phase.

Status	Meaning
ONL	Online. The drive is part of an array. If this drive fails, logical drives defined in the array in which this drive is grouped will have a status of offline (if the logical drive is assigned RAID level 0 with a good status) or Critical (if the logical drive is assigned RAID level 1 or level 5 with a good status).
RDY	Ready. The drive is recognized by the adapter and is available for definition.
TAP	Tape drive installed.
UFM	Unformatted. The drive requires a low-level format before it can be used in an array.
Blank Status	Any of the following circumstances can cause the status area to be blank: <ul style="list-style-type: none"> No hard disk drive is installed in that bay. The bay contains a hard disk drive, but the drive is not inserted correctly. An array was deleted and a defective drive is still in the bay. A new drive was installed and the configuration program has not been restarted. (The status will change to RDY when the RAID configuration program is restarted.)

Results of a Hard Disk Drive Failure: Depending on the circumstances, there can be several possible results from a drive failure.

Example 1:

Only one hard disk drive fails.
A hot-spare drive is defined that is the same or greater size than the failed drive.
The logical drives in the array are assigned RAID level 1, level 5, or a combination of these two levels.

Then the hot spare will take over immediately.

Note

Data for logical drives assigned RAID levels 1 and 5 is maintained; however, system performance will be reduced. Hot-spare drive capability does not apply to logical drives assigned RAID level 0.

Example 2:

Only one hard disk drive fails.
A hot-spare drive is not defined.
The logical drives in the array are assigned RAID levels 1, 5, or a combination of these two levels.

Then no data will be lost, but the system will operate at reduced performance until the defective drive is replaced and rebuilt.

Example 3:

If more than one drive fails, all data is lost. Therefore, it is important that you replace and rebuild a defective drive as soon as possible.

Logical and Hard Disk Drive Status Indications:

The status of the hard disk drive determines the status of the logical drives in the array in which the hard disk is grouped.

A single hard disk drive failure (indicated by a **DDD** status in the Bay/Array selection list) causes logical drives in that array that are assigned levels 1 and 5 to have a **Critical** status. Data remains in logical drives with a **Critical** status, but you must replace the one defective hard disk drive promptly, because if two hard disk drives were to fail, all of the data in the array would be lost.

After you install a new hard disk drive, the Replace process changes the drive status from **DDD** to **OFL** if there is a **Critical** logical drive. After the Rebuild process, the hard disk drive status changes from **OFL** to **ONL**.

A single or multiple hard disk drive failure causes logical drives in that array that are assigned level 0 to have an offline status. Data in logical drives with an offline status is lost. However, with a *multiple* disk drive failure, when the defective drives are part of the same array, logical drives in that array will have an offline status. This means that data is lost in all the logical drives in that array, regardless of which RAID level is assigned.

Replacing a Faulty Drive

Note

The hard disk drive indicator light will blink when the drive has failed and needs to be replaced (DDD state only).

To replace a faulty drive:

1. Start the RAID configuration program. See "Starting the RAID Configuration Program" on page 157.

If the drive failed while the system was powered down, a screen appears the next time the system is powered on showing you which drive is defective.

2. If the drive is not damaged (for example, it is not inserted correctly):
 - a. Power-off the system.

- b. Correct the problem.
 - c. Remove the diskette or ServerGuide CD from the drive.
 - d. Restart the system.
3. If the drive is defective:
- a. Press **Y** (Yes) to reconfigure the system.
 - b. Press **Ctrl+Alt+Del** when instructed to restart the system. The Main Menu appears.
 - c. Select **Rebuild device**.

At this point, the drive status shows **DDD**.

Warning

Removing the wrong hard disk drive can cause loss of all data in the array.

- d. Replace the defective drive. Refer to "Removing a Drive from Bank C, D, or E" on page 178.
- e. After you have replaced the drive, press **Enter**. The system will reconfigure to include the drive, and the drive's status will change to **OFL**.
- f. Allow the system to complete the configuration (the screen displays a completion message); then select **Rebuild drive**.
- g. Use the Up Arrow () key or the Down Arrow () key to highlight the **OFL** (offline) drive you want to rebuild; then press **Enter**.

The progress of the rebuilding process appears on the screen.
- h. When the rebuilding process completes, press **Esc** to return to the Main Menu. The new configuration will be saved automatically.
- i. Backup the new configuration (see "Backing Up Your Disk-Array Configuration" on page 170).
- j. Select **Exit** to end the RAID configuration program.
- k. Remove the diskette and press **Ctrl+Alt+Del** to restart the system.

Redefining Space in an Array: You can redefine space in a disk array in a number of ways. For example, you can combine a number of small logical drives to create a larger one or you can redefine the existing logical drive into several smaller drives. Also, you can install additional hard disk drives to create a larger logical drive than was possible with the existing storage capacity.

One method to redefine space in an array is to change the RAID level assigned to a logical drive. For example, if you assigned RAID level 1 to a logical drive and then decided you needed the capacity offered with RAID level 5, you can use this procedure to replace the existing logical drive with a logical drive assigned the new RAID level.

To redefine the space in a disk array, first you must delete the array. The last disk array defined must be the first deleted.

Warning

In all cases, when you delete an array, all the data and programs in the array are lost.

If you have data and programs that you want to save, they must be backed up and then restored. It is suggested you use a high-speed backup device, such as a tape drive.

To redefine the space in an array:

1. Back up all data and programs in the array.
2. If needed, install additional hard disk drives.

Refer to the *User's Reference* for information about selecting drive sizes.

3. Insert the IBM RAID controller diskette; then press **Ctrl+Alt+Del** to start the RAID configuration program.
4. Delete the existing array:
 - a. Select **Create/delete array** from the Main Menu. The Create/Delete Array menu will disappear.
 - b. Select **Delete disk array**. The cursor will be active in the Bay/Array list.
 - c. Review the Logical Drive List Date Created column; then press the Up Arrow () key or the Down Arrow () key to highlight the most recently defined array.

Note

You must delete disk arrays in descending order; the last one created must be the first one deleted.

- d. Press **Del**. The Confirm pop-up window appears.

Warning

All the data in the array will be lost during this procedure. Be sure to back up all data and programs that you want to save.

- e. If you do not want to delete the array, select **No**. To delete the array select, **Yes**.

Note

To use the hard disks from the existing array when creating a new array, you must confirm the deletion of the existing array. After you make your selection, the Confirm pop-up window will disappear, and the cursor will be active in the menu.

- 5. If you want a drive defined as a hot spare, refer to "Defining a Hot-Spare Drive" on page 159 for step-by-step instructions.
- 6. Create a new disk array and define logical drives. See "Creating a Disk Array" on page 161 for instructions on creating a disk array and defining logical drives.
- 7. After you have established the new array and logical drive or drives, select **Initialize/synchronize array** from the Main Menu; then select **Initialize logical drive** to prepare the drives in the array to receive data. This sets the drive to a predetermined state. Any data existing in the drive is overwritten with zeros, and corresponding parity is initialized to the proper value.
- 8. Insert a 3.5-inch formatted diskette in the primary drive, select **Advanced functions** from the Main Menu; then select **Backup config. to diskette**. Follow the instructions on the screen.
- 9. Exit the RAID configuration program by pressing **Esc** or selecting Exit while on the Main Menu. A pop-up window will appear asking you to confirm your action.
- 10. Reinstall your operating system and device drivers, then restore your data and programs.

Advanced Functions: You can select several utilities from the Advanced Functions menu. They include:

- Backup configuration to diskette
- Restore configuration to diskette
- Change the write policy
- Change the RAID parameters
- Format a drive

Backing Up Your Disk-Array Configuration: The RAID adapter maintains a record of the disk-array configuration information in its EEPROM (electronically erasable programmable read-only memory) module. The disk-array configuration is *vital information*. To protect this

information, back up the information to diskette as soon as you have completed your tasks. You need a blank, formatted, 3.5-inch diskette.

To back up the disk-array configuration information to diskette:

1. Label the blank diskette "Disk Array Configuration Backup," and date it.
2. Start the RAID configuration program. See "Starting the RAID Configuration Program" on page 157.
3. Select **Advanced functions** from the Main Menu.
4. Select **Backup config. to diskette**.
5. Remove the RAID controller diskette from the drive and insert the blank diskette.
6. Follow the instructions on the screen.

Restoring the Disk-Array Configuration: To restore the disk-array configuration information in the RAID adapter EEPROM module, use the RAID controller diskette and an up-to-date Disk Array Configuration Backup diskette.

Note

Because dynamic changes in the configuration of your disk array occur due to hot-spare drive replacement or other drive maintenance activity, the configuration backup information on the diskette might be different from that in the adapter. It is important that you back up the disk-array configuration information frequently, to keep the backup information on the diskette current.

To restore the RAID configuration information:

1. Insert the IBM RAID controller diskette into the primary drive and power-on the system. If the system already is on, press **Ctrl+Alt+Del**.
2. Select **Advanced functions** from the Main Menu.
3. Select **Restore config. from diskette**.
4. Follow the instructions on the screen.

Using the Advanced Functions: This section gives the procedures for using the advanced functions, such as changing the write policy, changing the RAID parameters, and formatting a drive.

Warnings appear throughout this section to alert you to potential loss of data and should be heeded before answering yes to the confirmations requested by the RAID configuration program.

Changing the Write Policy: When you configure a logical drive, the RAID adapter automatically sets the write policy to *write-through* (WT) mode, where the completion status is sent *after* the data is written to the hard disk drive. To improve performance, you can change this write

policy to *write-back* (WB) mode, where the completion status is sent *after* the data is copied to cache memory, but *before* the data is actually written to the storage device.

Although you gain performance with write-back mode, it creates a greater risk of losing data due to a power failure. This is because the system gets a completion status message when the data reaches cache memory, but *before* data is actually written to the storage device.

To change the write policy:

1. Start the RAID configuration program. See "Starting the RAID Configuration Program" on page 157.
2. Select **Advanced functions** from the Main Menu.
3. Select **Change write policy** from the Advanced Functions menu. The cursor will be active in the Logical Drive list.
4. Select the logical drive whose write policy you want to change. The Advanced Functions screen appears.

Note

Your information might be different from that shown in this screen.

The Logical Drive list shows you the logical drive ID, the size in megabytes of each logical drive, the RAID level you assigned to that logical drive, and the date you created it.

The status of the logical drive is also shown. **Good** means that all is well with the drive; **Critical** means that you must replace the hard disk drive and rebuild the logical drive. (You will have received a message telling you what has happened to the drive.) **Offline** means that the logical drive is unrecoverable; the data in that drive is lost.

5. Locate the **Wrt pol** (Write Policy) field in the Logical Drive list.

The write policy is shown as either **WT** (write-through, which is the default setting) or **WB** (write-back).

6. Use the Up Arrow () key or the Down Arrow () key to select the logical drive whose write policy you want to change.

Warning

If you change the write policy to write-back, wait at least 10 seconds after your last operation before you power-off the server. It takes that long for the system to move the data from the cache memory to the storage device. Failure to follow this practice can result in lost data.

7. Press **Enter** to change the write policy.

Notice that **WT** changes to **WB**. You can press **Enter** to alternate between **WT** and **WB**.

8. When you have made your choice, press **Esc** to return to the Advanced Functions menu.
9. Select **Exit**. The Confirm pop-up window appears asking you to confirm your action.
10. To return the setting to its original state, select **No**. To save your changes, select **Yes**.
11. Back up the disk-array configuration information to diskette. Refer to "Backing Up Your Disk-Array Configuration" on page 170 for more information.

Formatting Drives: You can perform a low-level format on drives with **RDY** (ready), **OFL** (offline), or **UNF** (unformatted) status.

Note

The **Format drive** choice on the Advanced Functions menu provides a low-level format. If you install a new hard disk drive that requires a standard format, use the Format command provided by your operating system.

The Format program works like the low-level format program in the advanced diagnostics portion of the system programs. It is provided in the IBM RAID configuration program so that you can perform a low-level format on a drive controlled by the RAID adapter.

To perform a low-level format:

1. Start the RAID configuration program. See "Starting the RAID Configuration Program" on page 157.
2. Select **Advanced functions** from the Main Menu.

Warning

A low-level format erases all data and programs from the drive.

3. Select **Format drive**. The low-level format program starts.
4. Follow the instructions on the screen.

You can perform a low-level format on more than one drive at a time.

Changing the RAID Parameters: You can change the RAID parameters using the advanced functions by selecting **Change RAID parameters**.

The default settings are:

Stripe unit size — 8K

The stripe unit size is the amount of data written on a given disk before writing on the next disk. To maximize the overall performance, this stripe unit should be chosen such that the stripe-unit size is

close to the size of the system I/O request. The default is set to 8K data bytes.

Warning

Once the stripe unit is chosen and data is stored in the logical drives, the stripe unit cannot be changed without destroying data in the logical drives.

Rebuild priority — Equal.

Rebuild priority can be set to equal, high, or low. When set to equal, the rebuild I/O request and system I/O request get equal priority in the execution order.

When set to high, the rebuild I/O request will get a higher priority than a system I/O request. In a heavily loaded system (with a high rate of system I/O requests), the high-priority rebuild can significantly reduce the disk rebuild time at the expense of degraded handling of I/O requests.

When the rebuild priority is set to low, the rebuild I/O requests can execute only if there is no pending system I/O requests. In a moderate to heavily loaded system, low rebuild priority will increase the disk rebuild time significantly and provide better system performance.

Note

Rebuild priority can be changed without affecting data in the logical drives.

Parity placement — RA.

Warning

Once a parity placement scheme is chosen and data stored, it cannot be changed without destroying data.

Parity placement defines how parity is placed in the disk array with respect to data. The following illustration shows both the Left Symmetric (LS) and Right Asymmetric (RA) parity placement in a four-drive disk array. Here AAA, BBB, and CCC are the data stripe units, and PP0 is the corresponding parity. Similarly DDD, EEE, and FFF are the data stripe units, and PP1 is the corresponding parity.

Right Asymmetric (RA)				Left Symmetric (LS)			
Disk 1	Disk 2	Disk 3	Disk 4	Disk 1	Disk 2	Disk 3	Disk 4
PP	AAA	BBB	CCC	AAA	BBB	CCC	PP
DDD	PP1	EEE	FFF	EEE	FFF	PP1	DDD
GGG	HHH	PP2	III	III	PP2	GGG	HHH
JJJ	KKK	LLL	PP3	PP3	JJJ	KKK	LLL

In some situations you may want to try LS parity placement to improve performance. The default parity placement is RA.

Read ahead — On.

Normally the IBM SCSI-2 Fast/Wide Streaming-RAID Adapter/A transfers data from disk to its local cache in steps of stripe-unit size. This provides excellent overall performance when workloads tend to be sequential. However, if the workload is random and system I/O requests are smaller than stripe-unit size, reading ahead to the end of the stripe unit will result in a wasted SCSI bus bandwidth and wasted disk utilization. When read-ahead is set to Off, the size of data transfer from the disk to local cache is equal to the system I/O request size, and no read-ahead to the end of the stripe unit is performed.

Notes

1. The Read-ahead setting can be changed without destroying data in a logical drive.
2. When the configuration is saved on a diskette, the RAID parameters are saved also.

Administration Monitoring Utilities: Several of the operating systems that your server supports also support (for disk-array models) RAID monitoring programs. The monitoring programs are:

OS/2* RAID Controller Administration and Monitor
OS/2 RAID NetFinity*/Alert Manager
OS/2 RAID Controller Administration for NetWare**
IBM RAID Controller Administration for Banyan**
Vines**

These programs include many of the functions contained in the IBM RAID configuration program, but unlike that program, they reside on top of your operating system and do not require you to start the program from a startable diskette or from a startable compact disc. You can start these programs from your active operating system desktop.

Each of these monitoring programs allow you view the RAID configuration, reconfigure the array when replacing a defective drive, and perform tuning tasks such as changing the write policy.

* Trademark of the IBM Corporation.

** NetWare is a trademark of Novell, Inc. Banyan and Vines are trademarks of Banyan Systems Inc.

To monitor the drive status with OS/2, Novell** NetWare, Microsoft** Windows**, and Banyan Vines, you must run the administration programs. The RAID controller diskette contains files that must be installed when you use OS/2, NetWare, or Banyan Vines.

See the README file on the RAID controller diskette for installation and usage instructions for OS/2 RAID Controller Administration and Monitor, OS/2 RAID Controller Administration for Netware, and IBM RAID Controller Administration for Banyan Vines. For OS/2 RAID NetFinity Alert Manager, see the ServerGuide CD documentation.

Drivers: The RAID adapter requires the installation of device drivers. See the README file on the RAID controller diskette for detailed instructions.

If you install OS/2 from the ServerGuide CD, the device drivers will be installed automatically. If, however, you install OS/2 from diskette, you will need to install the device drivers. See the README file on the RAID controller diskette.

Installing Internal Drives (Type 86XX): The Type 86XX server supports the following drive types:

- Diskette
- Hard disk
- Rewritable optical disc
- Tape

The server has hardware that lets you replace a failed hard disk drive without powering-off the server. Therefore, you have the advantage of continuing to operate your system while a hard disk drive is removed or installed. These drives are also known as *hot-swappable* drives.

Hot-swappable drives have a green LED that shines through the knob on the tray containing the drive. If the drive has a good electrical connection upon installation, the LED illuminates. The LED blinks briefly during power-up, and also blinks if the drive malfunctions.

Internal drives are installed in *bays*. A diskette drive and a CD-ROM drive are preinstalled in bay A in all models. A removable CD storage compartment is shipped in bay B1. You can install two drives in bay B. You can install hot-swappable hard disk drives in banks C, D, and E only. Banks C, D, and E each contain six bays. Bank C supports up to six drives. However, the total number of SCSI drives that you can install in bay B and bank C is six.

** Novell is a trademark of Novell, Inc. Microsoft and Windows are trademarks of Microsoft Corporation.

The number of preinstalled hard disk drives in bank C varies according to the model you purchased. You can install up to six drives in bank D and up to six drives in bank E.

Note

The bank letter-designations are located on both vertical rails on the front of the server. The bay-slot numbers are located on the top of bank C and the bottom of bank E.

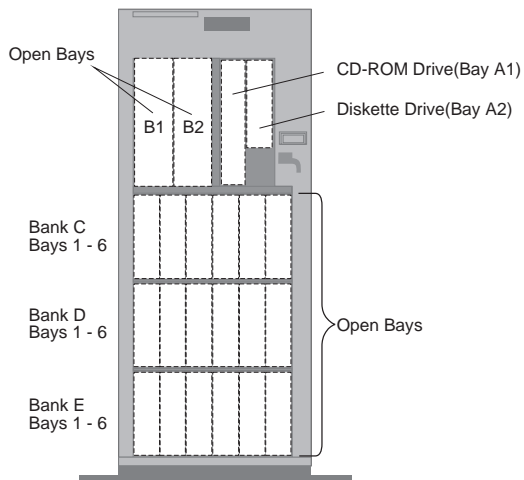

A *cover plate* (sometimes called a *bezel* or *face plate*) covers the front of bay B2 only. If you install a drive that uses removable media (diskette, optical disc, tape), you might install and adjust the cover plate after you install the drive in bay B2.

Considerations

Bay A comes with one SCSI CD-ROM drive and one 3.5-inch, 2.88MB diskette drive.

Bay B supports:

- One 5.25-inch, full-high, removable-media or non-removable-media device, or
- One 5.25-inch, half-high, removable-media device and one 3.5-inch, half-high, removable-media device, or
- Two 3.5-inch or two 5.25-inch, slim-high or half-high, removable-media devices.

Note

Only one of the devices installed in bay B can be a SCSI device.

You cannot install hot-swappable drives in bay B. PC Server 500 supports eighteen 3.5-inch, slim-high, hot-swappable hard disk drives, or nine 3.5-inch, half-high hard disk drives in the bottom three banks (C, D, and E).

Banks C, D, and E can accommodate six slim-high drives or three half-high drives, or a combination of both drive sizes. If you use a combination, remember that one half-high drive uses the equivalent space of two slim-high drives.

If you install drives in bank D or E, you will remove the fan assembly on the rear of the server, install a direct access storage device (DASD) *backplane* in banks D and E, and install an optional 220-watt power supply.

Each backplane has six connectors, to support up to six hard disk drives.

Removing a Drive from Bank C, D, or E: Locate the drive you are removing. You do not have to power-off the server to remove a drive from banks C, D, and E.

Warning

If you are removing a failed hard disk drive that is part of a *disk array* in bank C, D, or E, you must not accidentally remove a good drive. Before you attempt to remove a defective drive, thoroughly review the information displayed on your server's screen to determine the location of the failed drive. "Logical and Hard Disk Drive Status Indications" on page 167 explains the codes that your server uses to indicate a defective drive. When a hard disk drive fails, a blinking green indicator light illuminates on the knob of the drive tray. When a hard disk drive is good, a solid green indicator light illuminates on the knob of the drive tray.

If you partially or completely remove a good drive instead of the defective one, your server might lose valuable data. This situation is especially relevant if you assigned RAID level 1 or 5 to the logical drives in your disk array. However, the RAID controller can rebuild the data you need, provided that certain conditions are met. See "Starting the RAID Configuration Program" on page 157 for more details.

If you have a non-disk-array model, an illuminated drive tray knob means the drive is a good one. An unilluminated drive tray knob means the drive is defective, or no power is being supplied to the drive.

To remove a drive from bank C, D, or E, do the following steps:

1. Find the drive you plan to remove.

2. If you have a disk-array model and a drive has failed, ensure that you have selected the correct drive for removal by verifying that the light on the tray's knob is blinking.
3. Unlock the drive by turning the knob directly above it 90 degrees.
4. Disconnect the drive from the connector on the backplane, by grasping the handle on the drive tray and pulling the drive out of the server. Store the drive in a safe place.

Note

If you have a disk-array model, you must reconfigure your disk arrays after removing hard disk drives. See "Starting the RAID Configuration Program" on page 157 for details.

SCSI Controller on the System Board

On some models with SCSI on the system board, slot number 0 or 1 designates the logical position for the SCSI controller. Diagnostics might instruct you to replace the SCSI adapter in slot 0, or 1, leading you to believe that a SCSI adapter is missing. In that situation, replace the system board (the SCSI controller is built into the board).

SCSI Device Default Settings

You are here with a 000174XX error or you want to check the settings (defective devices can also cause incorrect settings).

The optional settings are intended to let the user share devices (usually external) between computers without having to reconfigure the system each time the device is moved. The settings apply to SCSI Presence Error Reporting devices (such as SCSI tape drives and CD-ROM drives and on some computers, hard disk drives). After a device is in the configuration table, the default settings are Enable and Keep. The only way to remove the device from the configuration table is to manually remove it by changing the settings. Running automatic configuration will not remove it from the configuration.

Enable and Disable Settings: If the user plans to leave the device turned off, or share the device periodically between different computers, that device should be set to Disabled (on the computers that will share the device). When disabled, the drive will remain in the configuration but POST will not report a configuration error when the device is removed. For example, before the user *temporarily* removes a SCSI tape drive, the setting should be changed to Disabled. When the device is reinstalled and the user no longer chooses to share the device, the setting should be changed back to Enabled.

Keep/Remove Settings: The only time that you will see the Keep and Remove options is when the device physically is disconnected from the computer. At that time, you have the option of removing the device from the configuration table by changing the setting to Remove.

Changing the Settings: To change the settings, do the following:

- Select **Set and View SCSI device configuration** from the **Set configuration** menu.
- Select the appropriate device on the list.
- Press **F6** to change the settings.
- Press **F10** to save the changes (in configuration).

SCSI Diagnostic Tests

The diagnostic tests usually identify the failing device, but because of the many dependencies, you can be misled by an error code. It is important to understand that all devices in a SCSI chain depend on an open line of communication on the SCSI data bus. Certain conditions can cause misleading error codes to appear. For example, a short circuit in the bus arbitration logic on the system board can inhibit communication between the system board and a SCSI adapter. If this condition exists, the error code that appears would indicate that the SCSI adapter failed when the failure was really on the system board.

SCSI ID (Using to Help Isolate Failures)

Each device on a SCSI chain has a unique SCSI ID. Use the SCSI ID to help pinpoint which device is failing. For more information see "Error Code Format" on page 115.

Servicing LAN Stations (Workstations)

Before you attempt to run the diagnostic tests on computers with no diskette drive, have the LAN administrator make the Diagnostic Diskette image available and bootable from the server.

Software/Hardware Mismatch Problems

If a failure appears to be the result of a defective FRU, but the diagnostic tests run error-free, there might be a software and hardware mismatch. These problems might be intermittent, and they can be difficult to diagnose.

If you are experiencing this type of problem, and the operating system is of the "direct driver" variety, which bypasses the BIOS interface, such as:

- AIX
- Netware**
- SCO** XENIX**
- Some "windowing" interfaces
- Other Unix-based software

the most-likely cause of the problem is a mismatch between the software and the hardware.

Applications that use the Multiprotocol Adapter/A, magnetic tape drives, and some SCSI devices such as CD-ROM, require direct software drivers. There is no BIOS interface for these devices in PS/2 products.

** Netware is a trademark of Novell, Inc.

** SCO is a trademark of Santa Cruz Operations, Inc.

** XENIX is a trademark of the Microsoft Corporation.

The following information is provided to help you resolve these problems:

Software/Hardware Compatibility

Direct-driver software is sensitive to variations in hardware design. The resulting incompatibilities are usually addressed with a revision (sometimes referred to as a patch), to the direct-driver software. Make certain the software is current and that all known revisions are installed. The IBM on-line bulletin board (sometimes referred to as PCPROD), and other software tools sources, such as Novell Netware, should be referenced by the software support personnel for any revisions provided by the appropriate software vendor.

The most-likely cause of these types of problems, when direct-driver software is involved, is the failure to obtain the latest revisions from the software vendor.

Software Installation

It is very important to follow the vendor's installation procedures. The software should not be migrated from another system, unless the installation instructions indicate that migration is supported (especially from a different model in the product line).

Important

Migrating adapters from slower systems to faster systems might cause problems. This is due to device-specific, system-specific, or time-dependent software code, that controls these devices.

Adapter and Software Compatibility

Hardware adapters for some operating systems must be approved by the software vendor to be compatible with that software. The approval is specific to the system, adapter E.C. level, and the software version. Contact the software vendor to confirm that system and adapter configuration is supported by their software level. The compatibility support is especially important for, (but not limited to), all LAN adapters and RIPL applications.

Software Failures After a Hardware Change

After the initial installation, any changes in the hardware configuration (addition or changes of adapters or features), might result in computer failures and require the reinstallation of the operating system or the software revisions.

Specific hardware configuration changes (such as memory address, interrupt level, or programmable option select), might result in a computer failure if the software has unique operating requirements.

Undetermined Problems

You are here because the diagnostic tests did not identify the failure, the Devices List is incorrect, or the system is inoperative.

Note

If you suspect a software mismatch is causing failures (solid or intermittent), be sure to see "Software/Hardware Mismatch Problems" on page 181.

Check the power supply voltages. If the voltages are not correct, replace the power supply. If the voltages are correct, return here and do the following:

1. Power-off the computer.
2. Remove or disconnect the following (one at a time) until you find the failure (power-on the computer and reconfigure each time).
 - Any external devices
 - Surge suppressor device (on the computer)
 - Modem, printer, mouse, or non-IBM devices
 - Each adapter
 - Drives
 - Memory-Module Kits
 - Bus adapter
 - Math coprocessor (if installed)

Minimum operating requirements vary for each computer. For example:

AT Bus computers require 256KB of memory.

Micro Channel computers require 1MB of memory.

IML drive in the drive startup sequence (IML systems only).

If the computer is a workstation, (no drives), a default hard disk drive is not required.

3. Power-on the computer. If the problem remains, suspect the system board, then the processor board in that order.

Note

If the problem goes away when you remove an adapter from the bus adapter, and replacing that adapter does not correct the problem, suspect the system board, processor board, then the bus adapter in that order.

VPD Codes Information

On 90 and 95, each processor board has a unique vital product data (VPD) code stored in the nonvolatile memory on the system board. After you change the processor board, run "Automatic configuration" to store the *new* processor board VPD code in nonvolatile memory.

On 56, 57, 76 and 77, each system board has a unique vital product data (VPD) code stored in the nonvolatile memory. After you replace the system board, run "Automatic Configuration," then select **Set system identification** utility from the Reference Diskette, System Partition (or server image) and input the system serial number when prompted.

Recording the Vital Product Data on a New System Board:

The vital product data (serial number, etc.) is stored in the EPROM on the system board. On some IBM PS/2 system boards, the vital product data (VPD) is rewritable. When replacing a system board that has rewritable VPD, the system unit serial number must be recorded on the new system board. Use the following procedure to record the system unit serial number on the new system board.

1. Power-on the computer.
2. During POST, press **F1**.
3. When the cursor moves to the lower left-hand corner, press **F1**.
4. Select item 8 **More Utilities**.
5. Select item 4 **Set System Identification**.
6. Select item 1 **Set System Identification**.
7. Type the system unit serial number in the entry field; then, press **Enter**.

The system unit serial number will be stored in the EPROM on the system board.

To verify that the serial number is properly stored in the EPROM, select **View System Configuration**.

System Board Locations

Model 25 System Board (Type 1)

- 1 Parallel port (J3)
- 2 Serial port (J5)
- 3 Pointing-device connector (J1)
- 4 Keyboard connector (J2)
- 5 Earphone connector
- 6 Keylock connector (J10)
- 7 Bus-adapter connector (J6)
- 8 Hard-disk-drive connector (J11)
- 9 Fan connector (J8)
- 10 Power connector (J7)
- 11 Display connector (J4)
- 12 Memory-module package 1
- 13 512KB memory (J9)
- 14 Memory-module package 2
- 15 Optional memory module ZM2
- 16 Optional memory module U34
- 17 Optional memory module U35
- 18 Optional memory module U22
- 19 Optional memory module U16
- 20 Optional memory module ZM1
- 21 8086 Microprocessor
- 22 Math coprocessor
- 23 Diskette connector (J12)

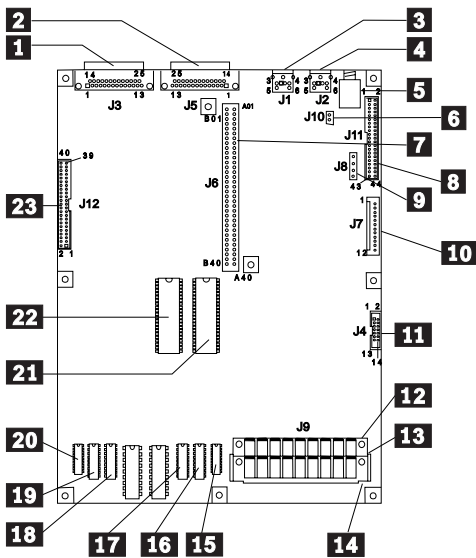

Model 25 System Board (Type 2)

- 1 Parallel port (J3)
- 2 Serial port (J5)
- 3 Pointing-device connector (J1)
- 4 Keyboard connector (J2)
- 5 Earphone connector
- 6 Keylock connector (J10)
- 7 Bus-adaptor connector (J6)
- 8 Hard-disk-drive connector (J11)
- 9 Fan connector (J8)
- 10 Power connector (J7)
- 11 Display connector (J4)
- 12 Memory-module package 1
- 13 512KB memory (J9)
- 14 Memory-module package 2
- 15 Optional memory module U35
- 16 Optional memory module U34
- 17 Optional memory module U22
- 18 Optional memory module U16
- 19 Optional memory module ZM2
- 20 Optional memory module ZM1
- 21 8086 Microprocessor
- 22 Math coprocessor
- 23 Diskette connector (J12)

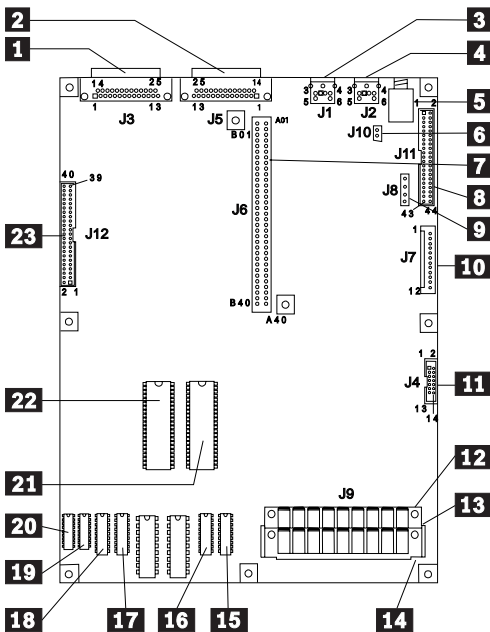

Model 25-286 System Board

- 1 Parallel port (J3)
- 2 Serial port (J5)
- 3 Bus-adaptor connector (J6)
- 4 Pointing-device connector (J1)
- 5 Keyboard connector (J2)
- 6 Memory packs (J9)
- 7 Optional memory packs (J10)
- 8 Hard-disk drive connector (J11)
- 9 Power-supply connector (J7)
- 10 Power-supply connector (J14)
- 11 Display connector (J4)
- 12 Password-override connector (J13)
- 13 80286 Microprocessor connector
- 14 Clock module connector (ZM35)
- 15 Math coprocessor connector (ZM1)
- 16 Diskette-drive connector (J12)

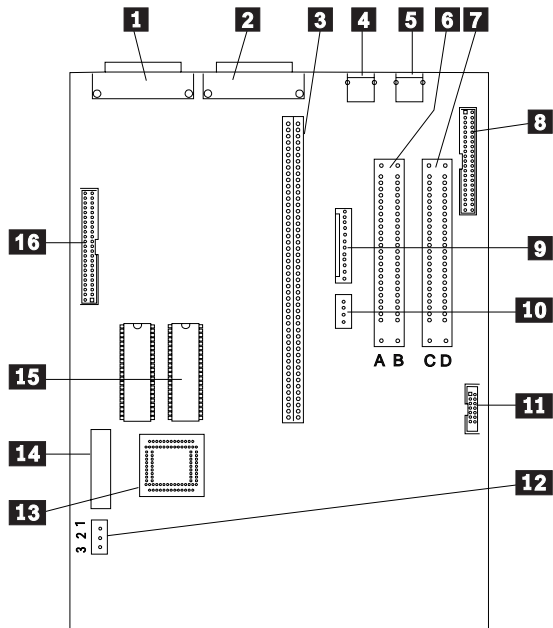

Model 25 SX System Board

- 1 Parallel port
- 2 Pointing-device connector
- 3 Keyboard connector
- 4 Serial port
- 5 External display port (not on K00)
- 6 Hard-disk power connector
- 7 Power-supply connector (J12 & J13)
- 8 Diskette-drive connector
- 9 Internal display connector
- 10 Hard-disk drive connector
- 11 Memory-module connector
- 12 Math-coprocessor socket
- 13 Password-override connector (J2)
- 14 Clock-battery socket
- 15 Bus-adaptor connector

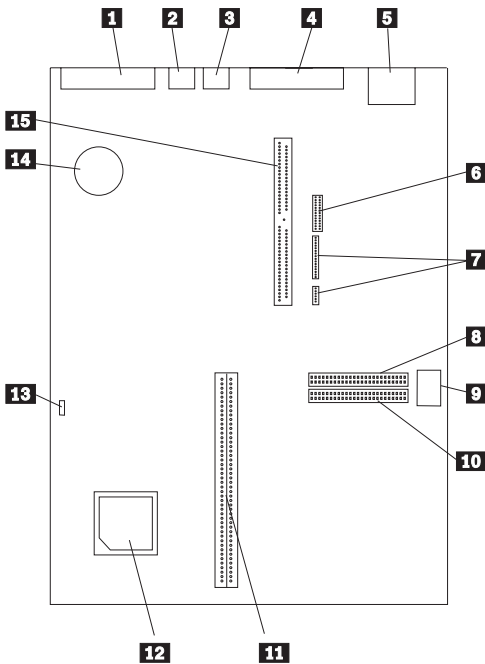

Model 30 System Board

- 1 Display connector
- 2 Serial port
- 3 Bus-adaptor connector
- 4 Parallel port
- 5 Pointing-device connector
- 6 Keyboard connector
- 7 Power-supply connector
- 8 8086 Microprocessor connector
- 9 Math-coprocessor connector
- 10 Keylock connector
- 11 Hard-disk drive connector
- 12 Diskette-drive connector
- 13 Memory-modules packages

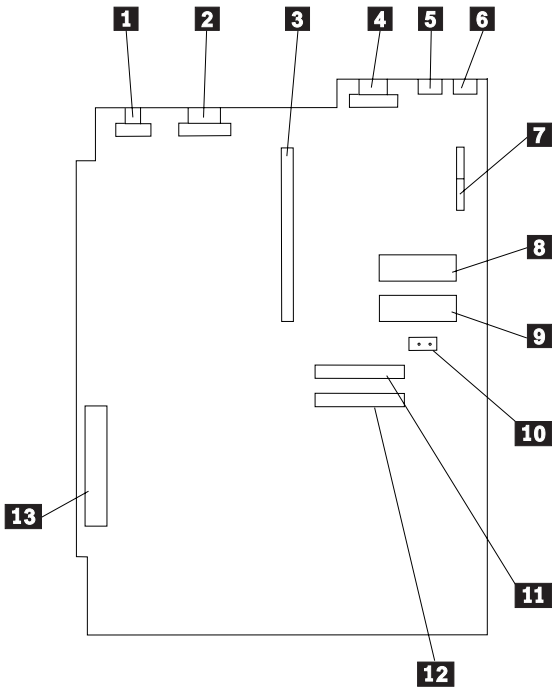

Model 30-286 System Board

- 1 Parallel port (J3)
- 2 Serial port (J5)
- 3 Bus-adaptor connector (J6)
- 4 Pointing-device connector (J1)
- 5 Keyboard connector (J2)
- 6 Memory packs (J9)
- 7 Optional memory packs (J10)
- 8 Hard-disk drive connector (J11)
- 9 Power-supply connector (J7)
- 10 Power-supply connector (J14)
- 11 Display connector (J4)
- 12 Password-override connector (J13)
- 13 80286 Microprocessor connector
- 14 Clock module connector (ZM35)
- 15 Math coprocessor connector (ZM1)
- 16 Diskette-drive connector (J12)

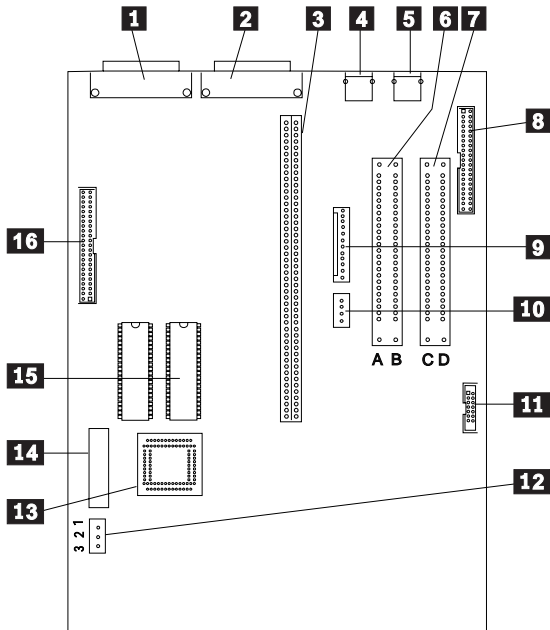

Model 33 System Board

Note: Some Model 35 and Model 40 computers use this system board.

- 1 Display connector
- 2 Pointing-device connector
- 3 Keyboard connector
- 4 Parallel port
- 5 Serial port
- 6 Control connector (Control Assembly)
- 7 Power-supply connector (P2)
- 8 Power-supply connector (P1)
- 9 Diskette-drive connector
- 10 80387SX Math coprocessor connector
- 11 Hard-disk drive connector
- 12 Password-override connector (J20)
- 13 Bus-adaptor connector
- 14 System board memory
- 15 Battery
- 16 Memory-module connector 2
- 17 Memory-module connector 1

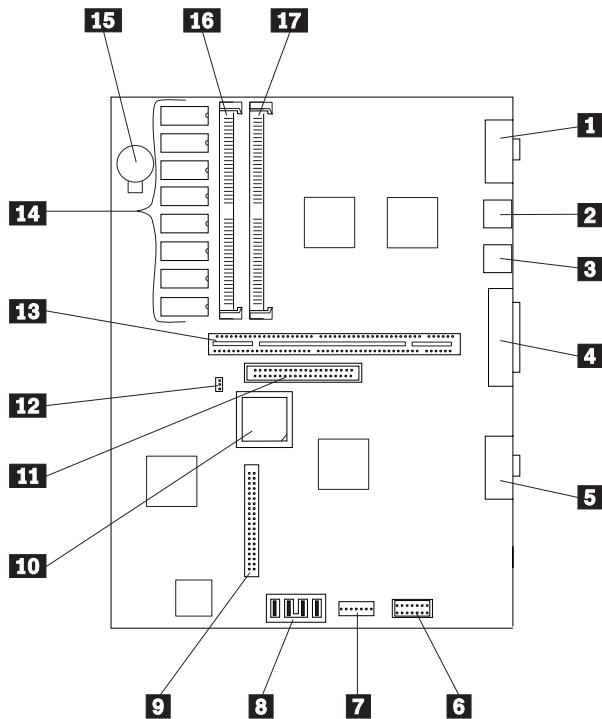

Model 35, 40 System Board

Note: See Model 33 note.

- 1 Real-time clock-module connector
- 2 Pointing-device connector
- 3 Keyboard connector
- 4 Parallel port
- 5 Serial port
- 6 Display connector
- 7 Control connector (Control Assembly)
- 8 Power-supply connector (P2)
- 9 Power-supply connector (P1)
- 10 Diskette-drive connector
- 11 Hard-disk drive connector
- 12 Password-override connector (J14)
- 13 80387SX Math coprocessor connector
- 14 Bus-adapter connector
- 15 Memory-module connector 1
- 16 Memory-module connector 2
- 17 Memory-module connector 3

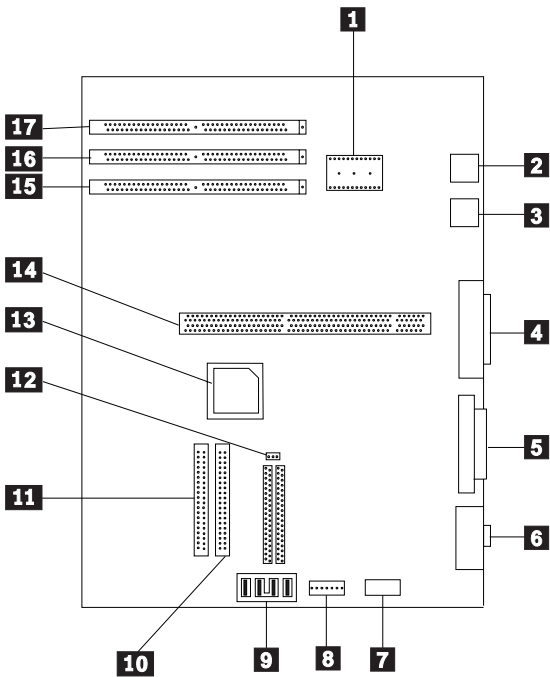

Model 50 System Board (Type 1)

- 1 Expansion slots
- 2 Extended video-adaptor slot
- 3 Hard-disk-drive bus-adaptor slot
- 4 Fuse
- 5 Fan-assembly connector
- 6 Memory-module package connectors
- 7 Diskette-drive bus-adaptor slot
- 8 80286 Microprocessor
- 9 Battery/speaker assembly connector
- 10 80287 Math coprocessor connector

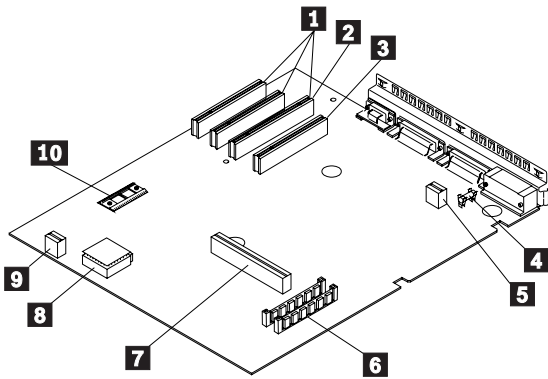

Model 50 System Board (Type 2)

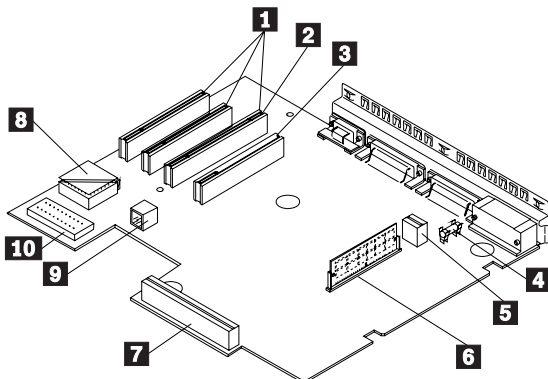

Models 50, 50Z 486SLC2 System Board Upgrade

- 1 Power-supply connector
- 2 Memory-module connectors
- 3 AT IDE hard disk drive connector
- 4 Diskette-drive cable connector
- 5 Coprocessor connector
- 6 Speaker connector
- 7 Password-override jumper (J11)
- 8 Processor connector
- 9 Expansion slots (16-bit)
- 10 Expansion slot (32-bit)
- 11 Expansion slots (16-bit)
- 12 Video connector
- 13 Serial connector
- 14 Parallel connector
- 15 Keyboard connector
- 16 Pointing-device connector

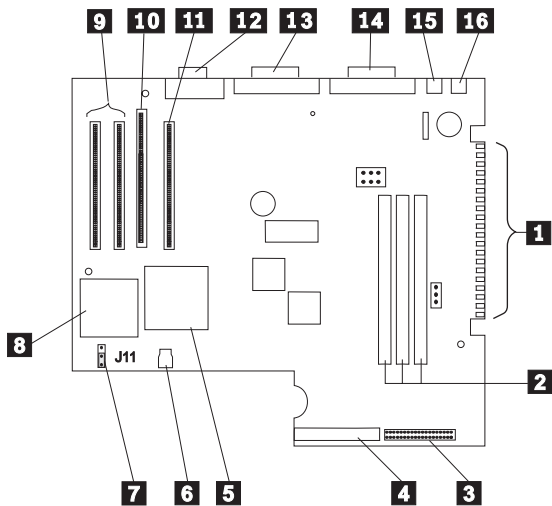

Model 53 (9553-xBx) System Board

- 1 Display connector
- 2 Serial port
- 3 Parallel port
- 4 Pointing-device connector
- 5 Keyboard connector
- 6 Memory-module connector M3
- 7 Memory-module connector M2
- 8 Memory-module connector M1
- 9 Power-supply connector (J8)
- 10 Hard-disk drive in-use light (J7)
- 11 Privilege access password jumper
- 12 Password-override connector (J11)
- 13 Power-supply connector (J12)
- 14 Hard-disk drive power connector
- 15 Diskette-drive cable connector
- 16 Hard-disk drive cable connector
- 17 Math coprocessor connector
- 18 486SLC2 processor
- 19 Real-time clock module
- 20 Bus-adaptor connector

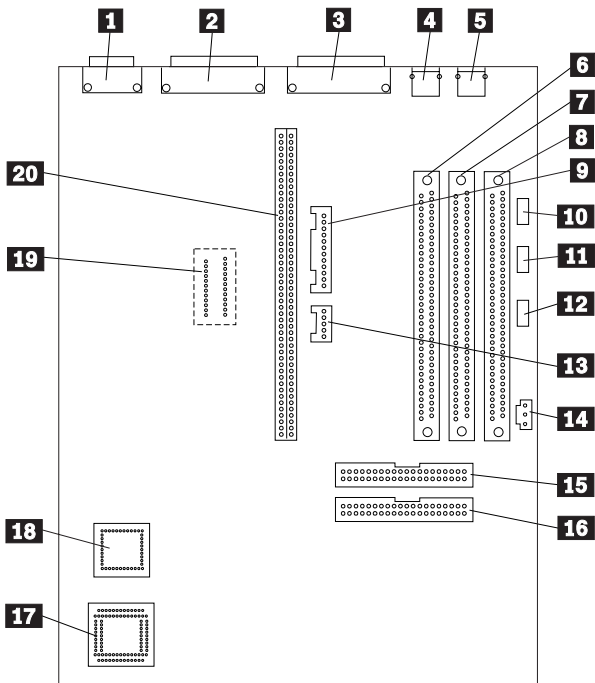

Model 55 System Board

- 1 Display connector
- 2 Serial port
- 3 Parallel port
- 4 Pointing-device connector
- 5 Keyboard connector
- 6 Fuse
- 7 Power-supply connector (P7)
- 8 Power-supply connector (P14)
- 9 Memory-module connector 1
- 10 Memory-module connector 2
- 11 Diskette-drive connector
- 12 80387SX Math coprocessor connector
- 13 Real-time clock-module connector
- 14 2KB CMOS RAM extension connector¹
- 15 Bus-adaptor connector

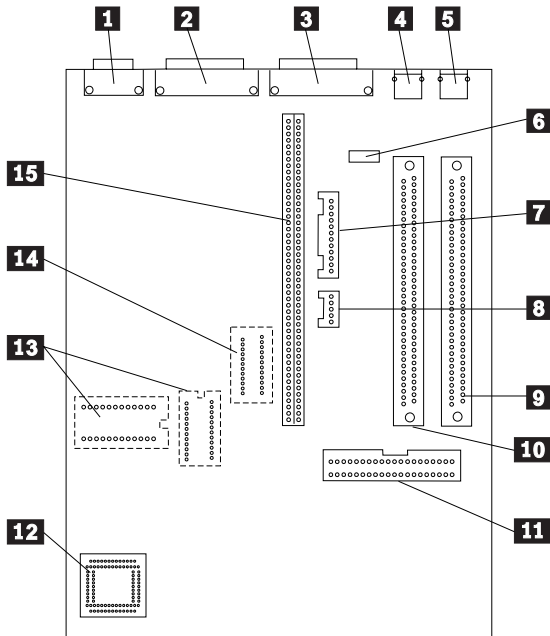

¹ May not be present on all system boards.

Model 55 486SLC2 System Board Upgrade

- 1 Power-supply connector (P7)
- 2 Password-override jumper (J11)
- 3 Power-supply connector (P14)
- 4 Hard-disk drive power connector
- 5 Memory-module connectors
- 6 AT IDE hard disk drive connector
- 7 Diskette-drive cable connector
- 8 Coprocessor connector
- 9 Processor connector
- 10 Bus-adaptor connector
- 11 Video-memory connectors
- 12 CD-ROM connector
- 13 Video connector
- 14 Serial connector
- 15 Parallel connector
- 16 Keyboard connector
- 17 Pointing-device connector

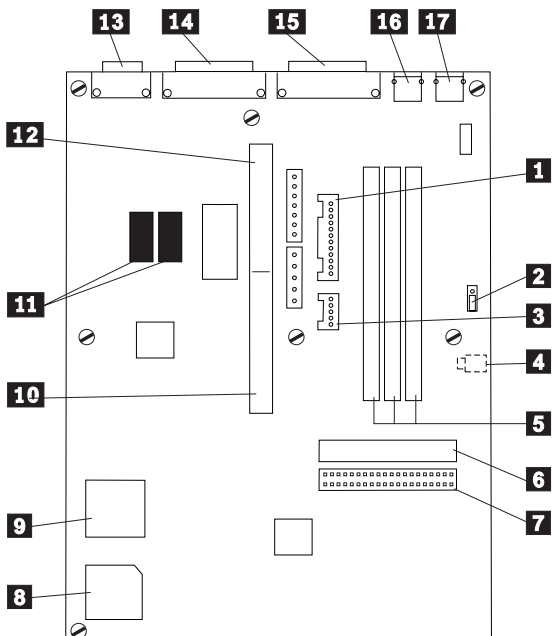

Model 56, 57 (8556, 8557) System Board

- 1 Pointing-device connector
- 2 Keyboard connector
- 3 Parallel-port connector
- 4 Password-override connector (J18)
- 5 Serial-port connector
- 6 Display connector
- 7 External SCSI connector
- 8 SCSI terminator
- 9 Control-assembly connector
- 10 Power-supply connector P2
- 11 Internal SCSI connector
- 12 Power-supply connector P1
- 13 Diskette-drive connector
- 14 Math coprocessor connector
- 15 Video memory connectors
- 16 Bus-adaptor connector
- 17 Memory-module connector 1 (MEM 1)
- 18 Memory-module connector 2 (MEM 2)
- 19 Memory-module connector 3 (MEM 3)

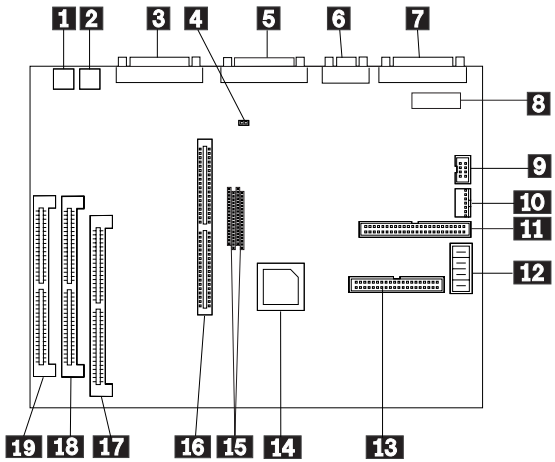

Model 56, 57 (9556, 9557) System Board

- 1 Pointing-device connector (J1)
- 2 Keyboard connector (J2)
- 3 Parallel-port connector (J3)
- 4 Override-jumper connector (JMP1)
- 5 Serial-port connector 1 (J4)
- 6 Privileged-access password Jumper
- 7 Serial-port connector 2 (J5)
- 8 Display connector (J7)
- 9 External SCSI connector (J6)
- 10 Internal SCSI connector (J16)
- 11 Control-panel connector (J19)
- 12 Power-supply connector P2 (J20)
- 13 Power-supply connector P1 (J18)
- 14 Diskette-drive connector (J21)
- 15 Math coprocessor connector (U35)
- 16 Bus-adaptor connector (J13)
- 17 Cover lock switch connector (J23)
- 18 Memory-module connector 1 (MEM 1)
- 19 Memory-module connector 2 (MEM 2)
- 20 Memory-module connector 3 (MEM 3)

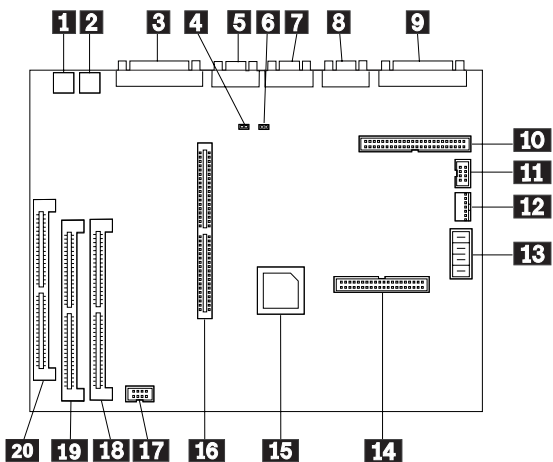

Model 60 System Board

- 1 Fuse
- 2 Power-supply cable connector
- 3 Diskette-drive cable connector
- 4 Memory-module package connectors
- 5 Battery/speaker assembly connector
- 6 80287 Math coprocessor connector
- 7 Expansion slots
- 8 Extended video-adaptor slot
- 9 Hard-disk-drive adapter slot
- 10 Display connector
- 11 Serial connector
- 12 Parallel connector
- 13 Pointing-device connector
- 14 Keyboard connector

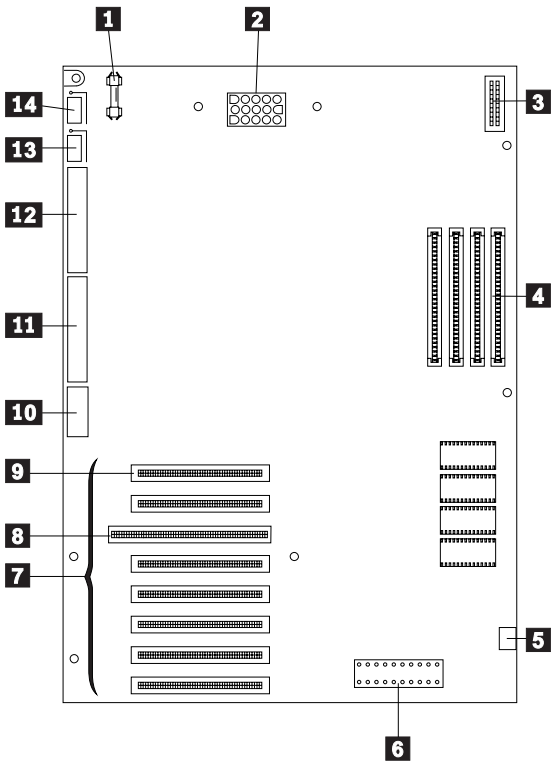

Model 65 System Board

- 1 Fuse
- 2 Power-supply connector
- 3 Real-time clock module connector
- 4 2KB CMOS RAM extension connector
- 5 Diskette drive connector
- 6 Memory-module-kit connector 1
- 7 Memory-module-kit connector 2
- 8 80387SX Math coprocessor socket
- 9 Speaker assembly connector
- 10 16-bit expansion slot
- 11 Video slot (slot 6)
- 12 Display connector
- 13 Serial connector
- 14 Parallel connector
- 15 Pointing-device connector
- 16 Keyboard connector

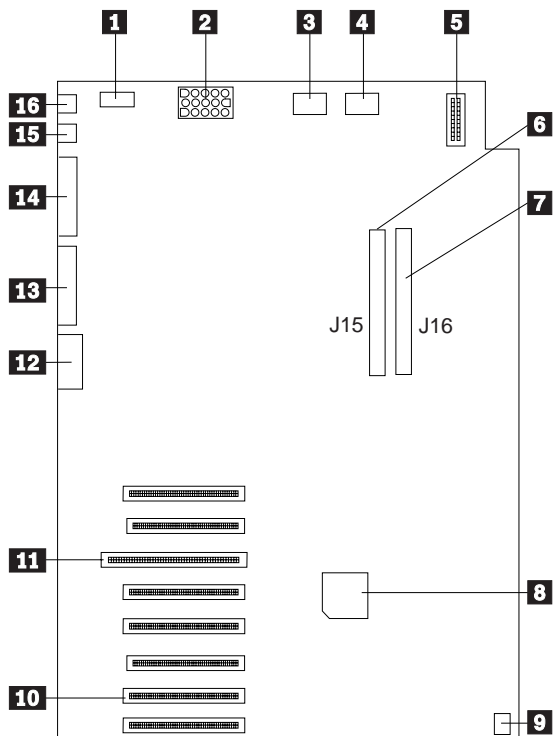

Models 60, 65, and 80 486DX2 and 486DLC2 System Board Upgrade

- 1 Expansion slots (32-bit)
- 2 Expansion slot (16-bit)
- 3 Expansion slots (video extension)
- 4 Expansion slots (32-bit)
- 5 Video connector
- 6 Serial connector
- 7 Memory connectors
- 8 Parallel connector
- 9 Pointing-device connector
- 1 Keyboard connector
- 11 Password-override jumper (J11)
- 12 Power-supply connector
- 13 Internal SCSI connector
- 14 Diskette-drive cable connector
- 15 Processor connector
- 16 Speed jumper (J9)
- 17 Speaker connector

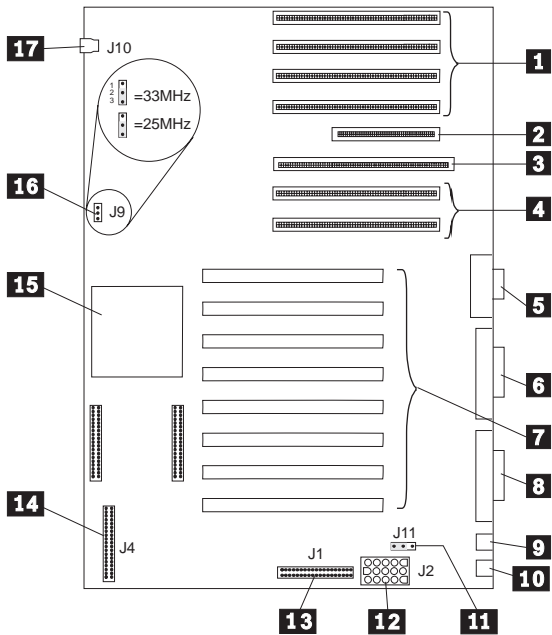

Model 70 System Board, Reduced Size (16 MHz, 20 MHz)

- 1 Battery/speaker assembly connector
- 2 Expansion slot 1 (16-bit)
- 3 Expansion slot 2 (32-bit)
- 4 Expansion slot 3 (32-bit)
- 5 80387 Math coprocessor connector
- 6 Hard-disk and diskette-drive bus-adaptor connector
- 7 Memory-module connector 1 (MEM 1)
- 8 Memory-module connector 2 (MEM 2)
- 9 Memory-module connector 3 (MEM 3)

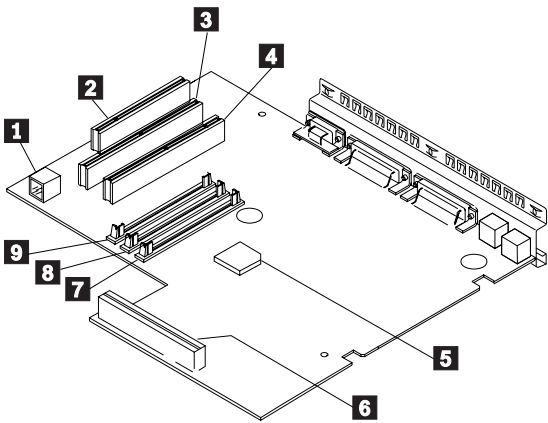

Model 70 System Board, Full Size (16 MHz, 20 MHz)

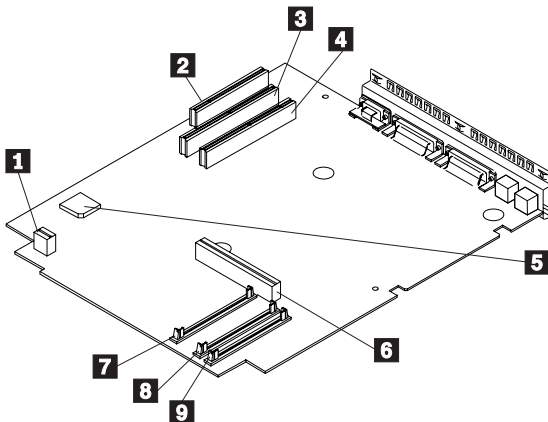

Model 70 System Board (25 MHz)

- 1 Battery/speaker assembly connector
- 2 Hard-disk and diskette-drive bus-adaptor connector
- 3 Expansion slot 1 (16-bit)
- 4 Expansion slot 2 (32-bit)
- 5 Expansion slot 3 (32-bit)
- 6 80387 Math coprocessor connector
- 7 Memory-module connector 4 (MEM 4)
- 8 Memory-module connector 3 (MEM 3)
- 9 Memory-module connector 2 (MEM 2)
- 10 Memory-module connector 1 (MEM 1)

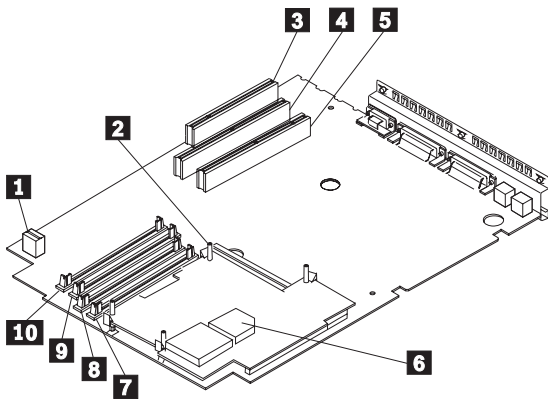

Model 70 486DX33 and 486DLC2 System Board Upgrade

- 1 Power-supply connector
- 2 Diskette-drive cable connector
- 3 Memory-module connectors
- 4 P23T Upgrade connectors
- 5 Password-override connector (J11)
- 6 Expansion slots
- 7 Video connector
- 8 Serial connector
- 9 Parallel connector
- 10 Pointing-device connector
- 11 Keyboard connector

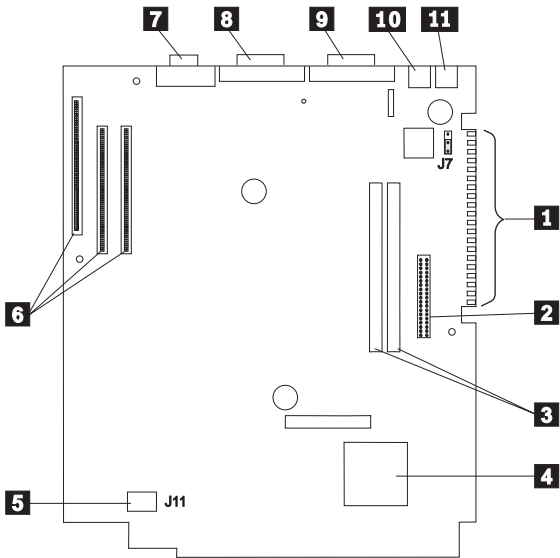

Model 76, 77 (9576, 9577) System Board

- 1 Pointing-device connector (J1)
- 2 Keyboard connector (J2)
- 3 Parallel-port connector (J3)
- 4 Serial-port connector 1 (J4)
- 5 Serial-port connector 2 (J5)
- 6 Oscillator-select jumper (SPD)
(25 MHz systems only)
- 7 Option microprocessor socket (U49)
(25 MHz and 33 MHz systems only)
- 8 External SCSI connector (J6)
- 9 Internal SCSI connector (J7)
- 10 Control-panel connector (J19)
- 11 Power-supply connector P2 (J18)
- 12 Power-supply connector P1 (J17)
- 13 Diskette-drive connector (J21)
- 14 Bus-adapter connector (J13)
- 15 Password-override connector (JMP1)

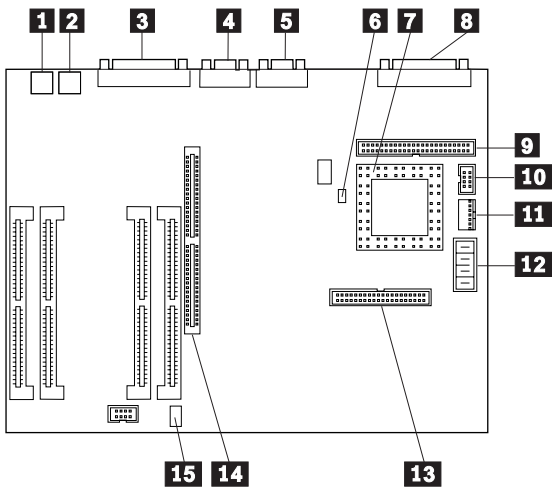

Model 80 (041, 071, 111, 121, 311, 321)

System Board

- 1 Power-supply connector
- 2 Diskette-drive connector
- 3 Memory expansion kit connectors
- 4 Math-coprocessor connector (8580-111, 121, 311, 321)
- 5 Battery/speaker connector
- 6 Math-coprocessor connector (8580-041, 071)
- 7 16-bit expansion slot
- 8 32-bit expansion slot
- 9 Video slot (slot 6)
- 10 Display connector
- 11 Serial connector
- 12 Parallel connector
- 13 Pointing-device connector
- 14 Keyboard connector

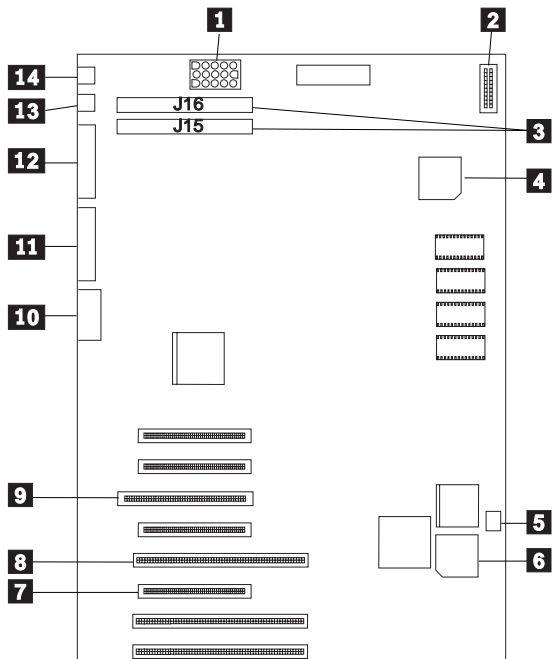

Model 80 (A16, A21, A31) System Board

- 1 Power-supply connector
- 2 Diskette-drive connector
- 3 Memory expansion kit connectors
- 4 Math-coprocessor connector
- 5 Battery/speaker connector
- 6 16-bit expansion slot
- 7 32-bit expansion slot
- 8 Video slot (slot 6)
- 9 Display connector
- 10 Serial connector
- 11 Parallel connector
- 12 Pointing-device connector
- 13 Keyboard connector

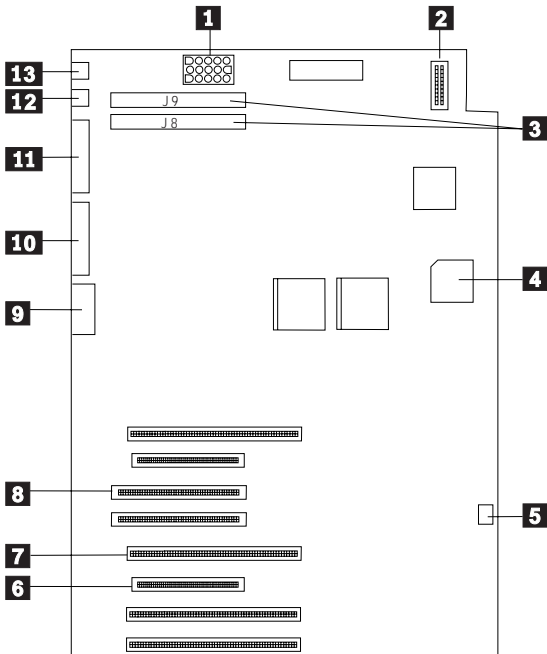

Server 85 (486) System Board

- 1 32-bit expansion slots
(video extensions J9, J11)
- 2 Internal SCSI connector
- 3 External SCSI connector
- 4 Parallel port
- 5 Serial port
- 6 Pointing-device connector
- 7 Keyboard connector
- 8 Memory-module connectors
- 9 Recovery jumper (JMP5)
- 10 Power-supply connector
- 11 Optional-microprocessor socket
- 12 Diskette-drive cable connector
- 13 Power-on password override connector (JMP1)
- 14 Indicator-Panel connector
- 15 Battery

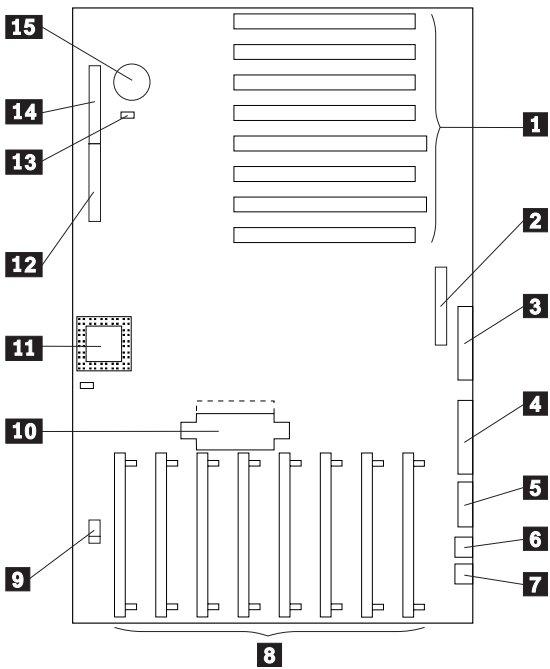

PS/2 9585-xKx, and 9585-xNx System Board

- 1 32-bit expansion slots
(video extensions J9, J11)
- 2 Internal SCSI connector
- 3 External SCSI connector
- 4 Parallel port
- 5 Remote power on jumper
- 6 Serial port
- 7 Pointing-device connector
- 8 Keyboard connector
- 9 Memory-module connectors
- 10 Tamper-evident connector
- 11 Power-supply connector
- 12 Processor
- 13 Cache connector
- 14 Diskette-drive cable connector
- 15 Password override connector (JMP1)
- 16 Control-panel connector
- 17 Battery
- 18 Privilege access password jumper
- 19 Server guard jumper (If a server guard is not installed, the jumper must connect the two pins closest to the control-panel connector.)

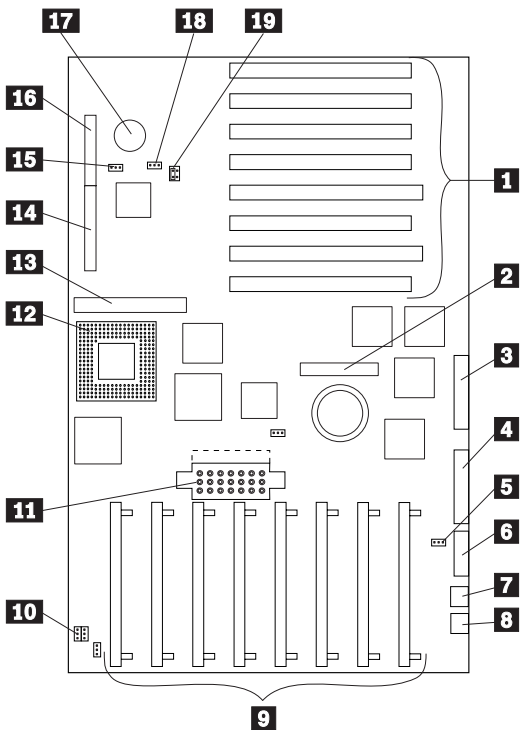

Model 90 XP 486 System Board

- 1 Power switch/speaker assembly (J2)
- 2 Battery (BT1)
- 3 SCSI adapter slot (J1)
- 4 Adapter slots (J1, J3, J4, and J6)
- 5 Processor-board slot (J8)
- 6 Memory-riser-card slot (J11)
- 7 Memory-riser-card slot (J14)
- 8 Video-memory connectors
- 9 Diskette-drive-cable connector (J15)
- 10 Power-supply connector (J25)
- 11 Power-supply connector (J26)
- 12 Power-on password override connector (J10)
- 13 Fan connector (J5)

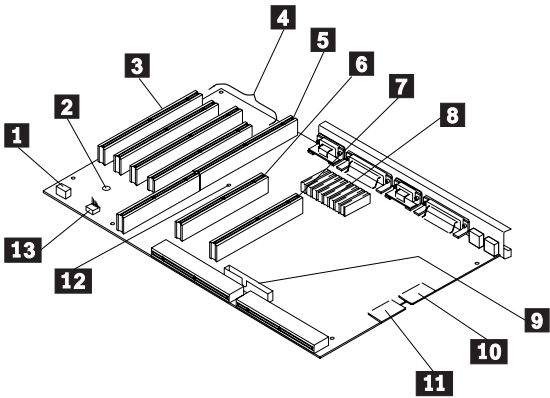

Model 95 XP 486 System Board

- 1 32-bit expansion slots
(video extensions J9, J11)
- 2 Processor-board slot
- 3 Serial connector
- 4 Parallel connector
- 5 J28 connector (access cover fan)
- 6 Pointing-device connector
- 7 Keyboard connector
- 8 Memory-module connectors
- 9 Power-supply connector
- 10 Power-on password override jumper (J16)
- 11 Battery connector
- 12 Diskette-drive cable connector
- 13 Information-panel cable connector

On the 486SX 25Mhz system board, the math coprocessor connector is located on the processor board.

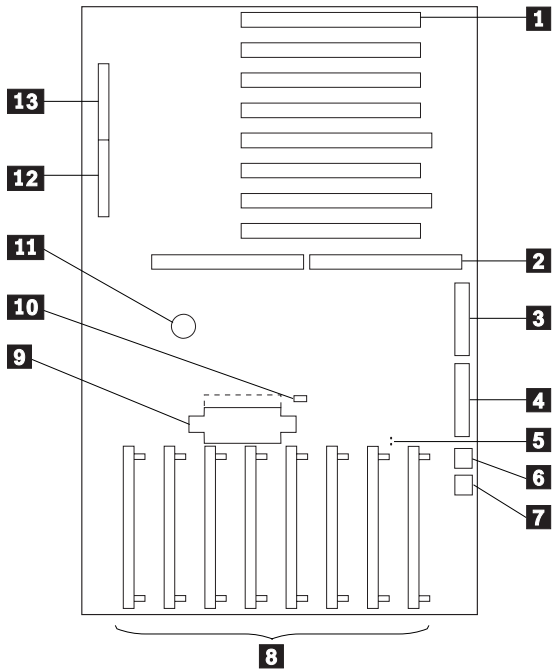

Server 9595, 9595A

- 1 32-bit expansion slots
(video extensions J25, J27)
- 2 Processor slot
- 3 Parallel ports
- 4 Serial ports
- 5 Keyboard/Pointing-device connectors
- 6 Power-on Features jumper
- 7 Power-on Password override jumper
- 8 Memory-module connectors
- 9 Tamper-evident cable connector
- 10 Power Supply connector
- 11 Privilege Access Password jumper
- 12 Battery
- 13 Diskette-drive cable connector
- 14 Reserved (Pins 1 and 2 must be connected.)
- 15 Operator-panel cable connector

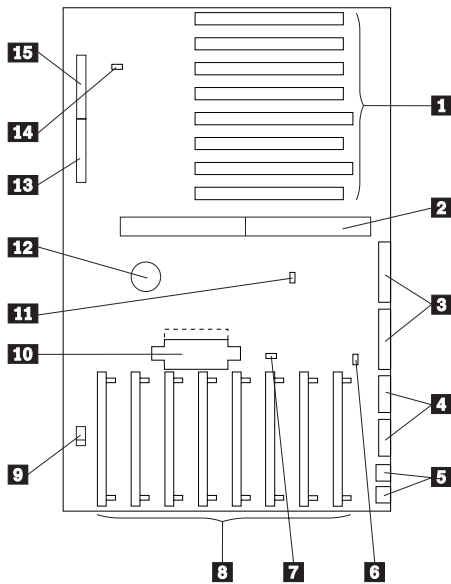

PC Server 486DX2 System Board

- 1 Memory connectors (U31, U32, U33, and U34)
- 2 Processor socket
- 3 ISA-IDE hard disk drive LED connector (W46)
- 4 PCI-IDE hard disk drive LED connector (W39)
- 5 Power LED pins 1-3 (W12)
- 6 Speaker connector (J5)
- 7 EISA slots (J12, J13, J14, 15, and J16)
- 8 PCI slots (J18, J19, and J20)
- 9 Mouse port (J2)
- 1 PCI-IDE hard disk drive connector (J21)
- 11 Keyboard port (J1)
- 12 Serial port, COM1 (J11)
- 13 Power supply connector, P2 (J7)
- 14 Power supply connector, P1 (J6)
- 15 Serial port, COM2 (J10)
- 16 Parallel port (J8)
- 17 Diskette drive connector (J9)
- 18 Real-time clock socket
- 19 IDE 2 hard disk drive connector (J22)

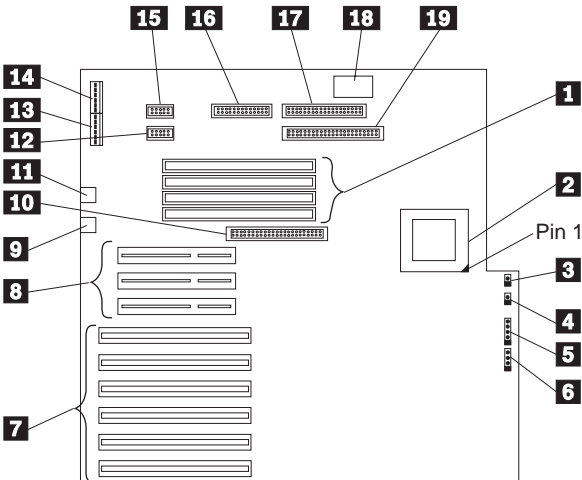

PC Server 486DX2 System Board Jumper Settings

A label showing the following jumper locations is located on the top of the base frame assembly inside the system unit.

Jumper Settings (CPU Selection)

Jumper	Configuration	Setting
W2	486SX All other CPUs (Default)	Pins 2-3 1-2 & 3-4
W3	P24T CPU All others CPUs (Default)	Not installed Installed
W16	25MHz 33MHz (Default)	Not installed Installed
W20	25MHz 33MHz (Default)	Installed Not installed
W33	DX4 DX4 internal double clock 468SX, DX2, DX, and DX4 internal clock tripler (Default)	Pins 1-2 Pins 2-3 Not installed

Jumper Settings (ISA IDE Selection)

Jumper	Configuration	Setting
W42	ISA IDE uses ISA IRQ 14 ISA IDE uses ISA IRQ 15	Pins 1-2 Pins 2-3
W43	ISA IDE uses DMA channel 6 ISA IDE uses DMA channel 7 ISA IDE uses P10 transfer (Default)	Pins 1-2 Pins 2-3 Not installed

Jumper Settings (Keyboard Selection)

Jumper	Configuration	Setting
W10	PS/2 Mouse installed (Default) PS/2 Mouse not installed	Installed Not installed

Jumper Settings (Tag Selection)

Jumper	Configuration	Setting
W24	7-Bit Tag 8-Bit Tag 9-Bit Tag (Default) Illegal	Not installed Installed Installed Not installed
W26	7-Bit Tag 8-Bit Tag 9-Bit Tag (Default) Illegal	Installed Installed Not Installed Not installed

Jumper Settings (BIOS Mode)

Jumper	Configuration	Setting
W6	BIOS in normal mode (Default) BIOS in boot recovery mode	Pins 2-3 Pins 1-2

Jumper Settings (DPU Selection)

Jumper	Configuration	Setting
W17	DPU generate parity CPU generate parity	Pins 1-2 Pins 2-3
W18	DPU forces parity error DPU does not force parity error (Default)	Pins 1-2 Pins 2-3

Jumper Settings (PCI Ports)

Jumper	Configuration
J20	PCI #1 (master/slave shared with EISA slot J17)
J19	PCI #2 (master/slave)
J18	PCI #3 (master/slave)

Jumper Settings (PCI Compliant IRQ Jumper Header)

Jumper	Setting
J101	Open (Default) Pin 2: Route to ISA IRQ1 Pin 3: Route to ISA IRQ3 Pin 4: Route to ISA IRQ4 Pin 5: Route to ISA IRQ5 Pin 6: Route to ISA IRQ6 Pin 7: Route to ISA IRQ7 Pin 8: Route to ISA IRQ8 Pin 9: Route to ISA IRQ9 Pin 10: Route to ISA IRQ10 Pin 11: Route to ISA IRQ11 Pin 12: Route to ISA IRQ12 Pin 13: Route to ISA IRQ14 Pin 14: Route to ISA IRQ15

Jumper Settings (Cache Selections)

Jumper	Configuration	Setting
W1	Secondary cache in write-through mode Secondary cache in write-back mode (Default)	Pins 1-2 Pins 2-3
W4	Internal cache in write-through mode (Default) Internal cache in write-back mode	Not installed Installed
W5	128KB of secondary cache 256KB of secondary cache (Default)	Not installed Installed

Jumper	Configuration	Setting
W21	Secondary cache not installed Secondary cache installed (Default)	Installed Not installed
W22	128KB of secondary cache 256KB of secondary cache (Default)	Installed Not installed
W23	128KB of secondary cache 256KB of secondary cache (Default)	Not installed Installed

Jumper Settings (PCI IDE Selection)

Jumper	Configuration	Setting
W35	PCI IDE uses ISA IRQ 14 (Default) PCI IDE does not use ISA IRQ 14	Installed Not Installed
W37	PCI IDE uses PCI INTR_A (Default) PCI IDE does not use PCI INTR_A (Default)	Installed Not Installed
W38	PCI uses ISA IRQ 15 PCI does not use ISA IRQ 15 (Default)	Installed Not Installed

Reserved Jumpers

Jumper	Setting
W8	Installed
W19	Installed

PC Server Pentium System Board

- 1 Memory connectors (J7, J8, J9, J10, J33, and J34)
- 2 IDE hard disk drive LED connector (W10)
- 3 Power LED connector (W9)
- 4 Speaker connector (J11)
- 5 Processor socket
- 6 EISA slots (J23, J24, J25, J26, and J27)
- 7 PCI slots (J30, J31, and J32)
- 8 Mouse port (J15)
- 9 Keyboard port (J14)
- 10 Serial port, COM1 (J20)
- 11 Power supply connector P1 (J12)
- 12 Power supply connector, P2 (J17)
- 13 Serial port, COM2 (J21)
- 14 Parallel port (J18)
- 15 Real-time clock socket
- 16 Diskette drive connector (J19)
- 17 Power supply connector, P3 (J37)
- 18 IDE 2 hard disk drive connector (J22)

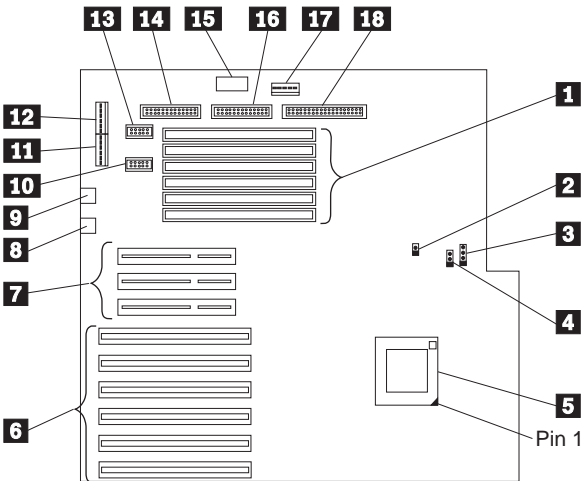

PC Server Pentium System Board Jumper Settings

A label showing the following jumper locations is located on the top of the base frame assembly inside the system unit.

Jumper Settings (Parity Check)

Jumper	Configuration	Setting
J1	Pentium parity check enabled (Default) Pentium parity check disabled	Installed Not installed

Jumper Settings (DRQ Selection)

Jumper	Configuration	Setting
W14	DRQ6 DRQ7	Pins 1-2 Pins 2-3

Jumper Settings (Secondary Cache Selection)

Jumper	Configuration	Setting
J40	5 volts for the Pentium 5.3 volts for the Pentium	Installed: Jumper blocks (all pins) Installed: Power module
J41	5.3 volts for ground	Installed: Power module (ground)
J42	5.3 volts for ground	Installed: Power module (ground)

Selected Jumper Default Setting

Jumper	Default Setting
J3	Pins 2-3
J4	Pins 1-2
J35	Pins 1-2

Jumper Settings (Cache Selection)

Jumper	Configuration	Setting
J2	Pentium write-through cache Pentium write-back cache (Default)	Installed Not installed

Jumper Settings (DACK Selection)

Jumper	Configuration	Setting
W16	DACK 6 DACK 7	Pins 1-2 Pins 2-3

Jumper Settings (Keyboard Selection)

Jumper	Configuration	Setting
W6	PS/2 Mouse installed (Default) PS/2 Mouse not installed	Installed Not installed

Jumper Settings (Clock Selection)

Jumper	Configuration	Setting
J5	66MHz clock speed (Default) 50MHz clock speed	Installed Not installed

Jumper Settings (Pentium Clock Selection)

Jumper	Configuration	Setting
J6	Oscillator for U15 (Default) Clock synthesizer	Pins 1-2 Pins 2-3

Jumper Settings (BIOS Mode)

Jumper	Configuration	Setting
W2	BIOS in boot recovery mode BIOS in normal mode (Default)	Pins 1-2 Pins 2-3

Secondary Cache Selection

Configuration	J3	J4	J35
No secondary cache	Pins 1-2	Pins 1-2	—
Reserved	Pins 1-2	Pins 2-3	—
256KB secondary cache	Pins 2-3	Pins 1-2	Pins 1-2
512KB secondary cache	Pins 2-3	Pins 2-3	Pins 2-3

Jumper W17 IRQ Selection

Selection	Setting
Redirect modified PCI interrupt to IRQ 5	Pins 1-2
Redirect modified PCI interrupt to IRQ 9	Pins 3-4
Redirect modified PCI interrupt to IRQ 10	Pins 5-6
Redirect modified PCI interrupt to IRQ 11	Pins 7-8
Redirect modified PCI interrupt to IRQ 15	Pins 9-10
Redirect modified PCI interrupt to IRQ 14	Pins 11-12

Reserved Jumpers

Jumper	Setting
W20	Pins 2-3
J5	Installed
J6	Pins 1-2

Parts Catalog

Warning

Follow "Handling Electrostatic Discharge-Sensitive Devices" on page 369 before handling any electronic parts.

Model 25, 25-286, 25SX (8525) Parts	223
Model 30 (8530) Parts	227
Model 30-286 (8530) Parts	229
Model 33 (9533) Parts	231
Model 35 (8535) Parts	233
Model 40 (8540) Parts	236
Model 50 (8550) Parts	239
Model 53 (9553) Parts	241
Model 55 (8555) SX Parts	243
Model 56 (8556) Parts	246
Model 57 (8557) Parts	248
Model 60 (8560), 65 (8565), and 80 (8580) Parts	251
Model 70 (8570) Parts	254
Models 56, 76 (9556, 9576) Parts	257
Models 57, 77, M57, M77 (9557, 9577) Parts .	260
Model 90 (8590) Parts	263
PC Server (8640) Parts	267
PC Server 500 (Type 86XX) Parts	270
Server 85 (9585), Model 95 XP 486 (8595) Parts	273
Server 9595, PS/2 9585-xKx, and PS/2 9585-xNx Parts	277
Server 9595A Parts	280
Model 3509 Parts	285
Model 3510 Parts	287
Model 3511 Parts	289
Model 3532 Parts	291
OBI DASD Hot Swap Storage Expansion Enclosure Parts	293
Common Parts	295
486 DX, DX2, DLC2, SLC, SLC2 System Board Upgrade Parts	295
CD-ROM Drives	296
Element Exchange Displays	297
External Diskette Drives	298
Keyboard/Mouse	298
Miscellaneous Parts Kits	300
Power Cords	304
Rewritable Optical Drives	305
ServerGuard Adapter Parts	306
SCSI Adapter Terminators	308
Tools and Miscellaneous	308
Wireless LAN Adapter (ISA, Micro Channel Bus)	309
Wireless LAN Adapter (PCMCIA Type II)	310
Options and Adapters Matrix	311

Model 25, 25-286, 25SX (8525) Parts

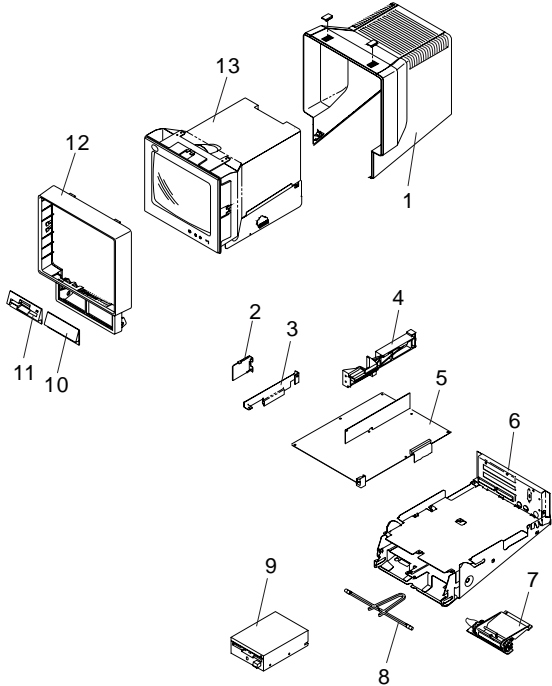

Index	System Unit (25, 25-286, 25SX)	
1	Top Cover	00F2110
2	Audio Card Jack Assembly (25-286)	64F0184
	Clock Module (25-286)	8509237
	Clock Battery (25SX)	33F8354
	Front Bezel/Logo (25) (R)	61X8908
	Logo Package (25) (R)	00F2119
	Rear Cover	61X8916
3	Bracket, Bus Adapter (25SX only)	96F7347
3	Bracket, Bus Adapter	64F0220
	Bracket, Center Rib	64F0221
	Bracket, Base Rear	64F4100
4	Bus Adapter (25)	00F2101
	Bus Adapter Support	00F2118
4	Bus Adapter (25-286)	64F0182
4	Bus Adapter (25SX)	04G1631
5	System Board (25)	96F7390
	Memory Module (64KB) (ZM1, ZM2)	00F2120
	Memory Module (64KB) (U16, U22, U34, U35)	00F2121
	Memory Module (256KB)	61X8906
	8087 Math Coprocessor	61X8922
	80287 Math Coprocessor	72X8528
5	System Board (25-286)	96F7435
	Memory Pack (256KB)	1497256
	Memory Pack (1MB)	74X8637
5	System Board, 1MB memory (25SX)	42G2802
5	System Board, 4MB memory (25SX)	42G2803
	1MB Memory Module Kit (85ns)	90X8624
	2MB Memory Module Kit (70ns)	92F0102
	2MB Memory Module Kit (80ns)	92F0103
	2MB Memory Module Kit (85ns)	92F0104
	4MB Memory Module Kit (70ns)	92F0105
	8MB Memory Module Kit (70ns)	64F3606
	8MB Memory Module Kit (80ns)	64F3607
6	Base Frame Assembly (25)	00F2104
6	Base Frame Assembly (25-286, 25SX)	64F0218
7	Tilt Assembly	00F2105
	Foot Assembly	00F2114
8	Retainer - Base to Cover	00F2134
	I/O Panel (25 286)	64F0219
	I/O Panel (25SX)	10G3698
	Bracket, Center Rib	64F0221
9	See DASD	
10	Diskette Blank Bezel	00F2117
11	(see DASD)	
12	Cover - Front Bezel	00F2111
13	Display Assembly (with logo)(25SX only) 115/230 V, Northern Hemisphere	92F0692
13	Color Display Assembly (110/220V) (8525) U.S. and Canada	00F2053
13	Color Display Assembly (8525) (Northern Hemisphere)	00F2056
13	Color Display Assembly (8525) (Southern Hemisphere)	00F2057
13	Color Display Assembly (8525-286) (110/220V) (Northern Hemisphere)	64F0181
13	Color Display Assembly (8525-286) (110/220V) (Southern Hemisphere)	64F0186

Index	System Unit (25, 25-286, 25SX)	
13	Monochrome Display Assembly (110/220V) U.S. and Canada	00F2052
13	Monochrome Display Assembly (Northern Hemisphere)	00F2054
13	Monochrome Display Assembly (Southern Hemisphere)	00F2055
	Miscellaneous Parts Kit (see page 300)	00F2113
	Shipping Material	00F2115

Index	DASD (25)	
9	720KB Diskette Drive (1/3 and 1/2 Ht. Kit.) ² Kit Includes: Cable Converter Models 25 and 30 Diskette Drive Bezel	96F7678
	Diskette Drive Shipping Insert	60X5599
	Diskette Drive Shipping Insert (Note: Order both inserts)	60X5600
11	Diskette Drive Bezel (1/2 Ht.) ²	00F2112
	Diskette Drive Cable (1/2 Ht.) ²	33F4949
	Diskette Drive Shield (1/2 Ht.) ²	33F4904
11	Diskette Drive Bezel (1/3 Ht.) ³	33F4947
	Diskette Drive Cable (1/3 Ht.) ³	33F4949
	Diskette Drive Spacer (1/3 Ht.) ³	33F4948
	20MB Hard Disk Drive	61X8929
	170MB Hard Disk Drive	71G4958
	245MB Hard Disk Drive	61G3754
	420MB Hard Disk Drive	71G4930
	Hard Disk Drive Cable (for 61X8929)	78X9089
	Hard Disk Drive Bezel, Keylock, and Switch Assembly	78X9088

Continued on next page.

Index DASD (25-286)

9	1.44MB Diskette Drive	64F0162
11	Diskette Drive Bezel	00F2112
	Diskette Drive Cable	33F4949
	20MB Hard Disk Drive	6128285
	30MB Hard Disk Drive	6128279
	Terminator (for 6128279)	92F0269
	170MB Hard Disk Drive	71G4958
	245MB Hard Disk Drive	61G3754
	420MB Hard Disk Drive	71G4930
	Hard Disk Drive Cable	64F0183
	Tray, Hard Disk Support	64F4101
Hard Disk Drive Bezel with Keylock	64F0185	

Index DASD (25 SX)

9	1.44MB Diskette Drive	64F0162
	Diskette Drive Cable	04G1632
11	Diskette Drive Bezel	00F2112
	40MB Hard Disk Drive	04G1630
	80MB Hard Disk Drive	92F0152
	170MB Hard Disk Drive	95F4728
	170MB Hard Disk Drive	71G4958
	245MB Hard Disk Drive	61G3754
	420MB Hard Disk Drive	71G4930
	Hard Disk Drive Power Cable	04G1618
	Hard Disk Drive Signal Cable	04G1633
	Hard Disk Drive Mounting Tray	96F7344
Hard Disk Drive Bezel with Cover Lock	64F0185	

² All 8525 systems below S/N ZZ999.

³ All 8525 systems above S/N 0100000.

Model 30 (8530) Parts

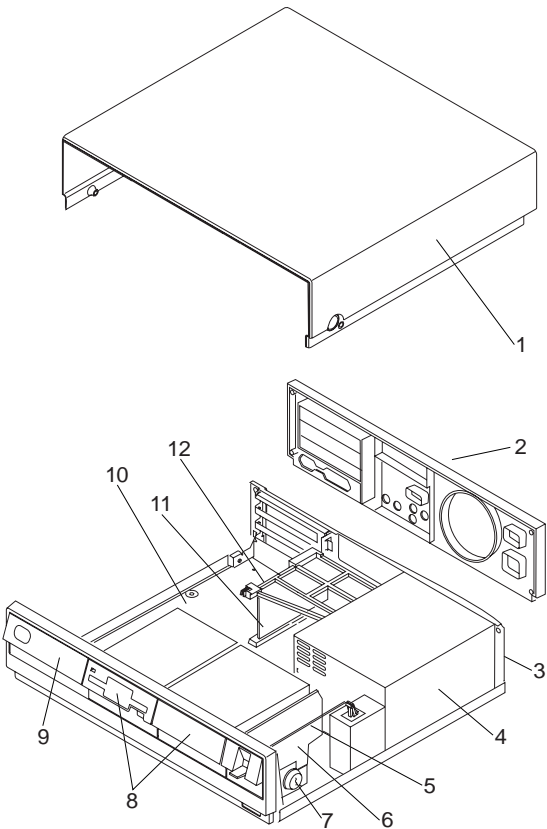

Index System Unit (30)

1	Top Cover	61X8913
2	Rear Cover	61X8916
3	Base Frame Assembly (R)	61X8897
4	Power Supply (120/220V)	61X8905
	Sliding Support Bracket	61X8926
	Support Bracket	61X8914
5	Power Switch Link	61X8919
6	Drive Cradle	61X8909
7	Keylock Assembly	61X8912
	Power Switch	61X8918
9	Front Bezel/Logo (R)	61X8908
10	System Board ⁵ (use if S/N not in note)	61X8907
10	System Board ⁵ (use if S/N in note)	33F8474
	System Board Clip	61X8933
	Memory Module Package (256KB)	61X8906
	8087 Math Coprocessor	61X8922
	Rubber Feet (Qty 4)	61X8917
	Miscellaneous Parts Kit (see page 302)	61X8915
11	Bus Adapter	61X8910
12	Bus Adapter Support	61X8911
	Shipping Carton	72X7541

Index DASD (30)

	720KB Diskette Drive (1/3 and 1/2 Ht. Kit.) ⁶	96F7678
	Kit Includes: Cable Converter	
	Models 25 and 30 Diskette Drive Bezel	
	Diskette Drive Cable (1/2 Ht.)	61X8900
8	Diskette Drive Bezel (1/2 Ht.)	90X9299
	Diskette Drive Cable (1/3 Ht.) ⁶	34F0002
8	Diskette Drive Bezel (1/3 Ht.) ⁶	27F4230
	20MB Hard Disk Drive ⁴	6128285
	20MB Hard Disk Drive (All others)	61X8929
	30MB Hard Disk Drive	6128279
	170MB Hard Disk Drive	71G4958
	245MB Hard Disk Drive	61G3754
	420MB Hard Disk Drive	71G4930
	Terminator (for 6128279)	92F0269
8	Hard Disk Drive Bezel	61X8904
	Hard Disk Drive Cable (8530-001)	27F4178
	Hard Disk Drive Cable (8530-021)	61X8903

⁴ All 8530-001 systems, and 8530-021 systems with S/N 2500000 to 2999999 and S/N 55AA001 to 55ZZ999.

⁵ All 8530-001 systems, 8530-002 systems with S/N 55A0001 to 55Z9999 and S/N 7000000 to 7499999, 8530-021 with S/N 2500000 to 2999999 and S/N 55AA001 to 55ZZ999.

⁶ All 8530-001 systems, 8530-002 systems with S/N 55A0001 to 55Z9999 and S/N 7000000 to 7499999, 8530-021 with S/N 2500000 to 2999999 and S/N 55AA001 to 55ZZ999.

Model 30-286 (8530) Parts

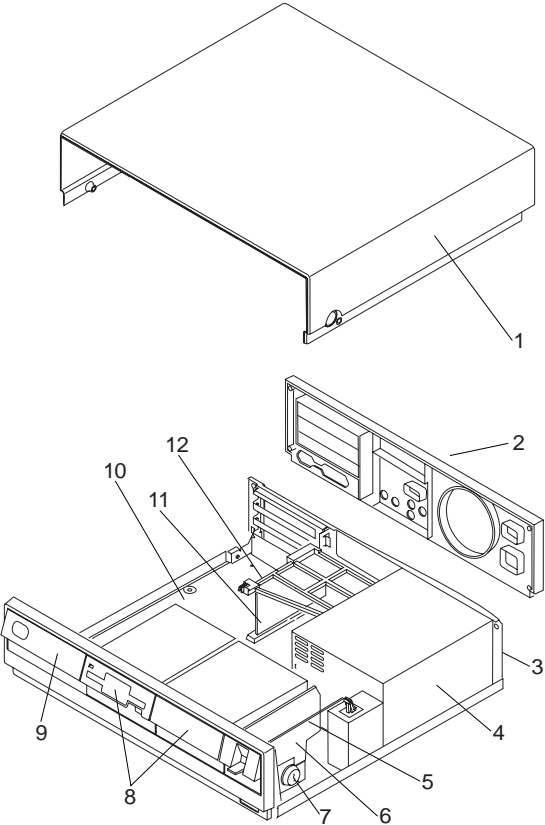

Index System Unit (30-286)

1	Top Cover	27F4172
2	Rear Cover	27F4174
3	Base Frame Assembly (R)	27F4167
4	Power Supply (120/230V)	27F4166
	Back Panel (I/O Panel)	27F4229
5	Power Switch Link and Lever	27F4168
6	Drive Cradle	27F4170
7	Cover Lock Assembly	27F4169
8	(see DASD)	
9	Front Bezel (no Logo)	27F4173
	Front Cover Logo (R)	27F4249
10	System Board (All Models)	10G4109
	Memory Pack (256KB)	1497256
	Memory Pack (1MB)	74X8637
	System Board Clip	61X8933
	Clock Module	8509237
11	Bus Adapter	27F4164
12	Bus Adapter Support	27F4165
	Support Bracket	61X8914
	Sliding Support Bracket	61X8926
	System Board Video Cable	27F4163
	80287 Math Coprocessor	72X8528
	Miscellaneous Parts Kit (see page 301)	27F4171
	Shipping Carton	83X9431

Index DASD (30-286)

	1.44MB Diskette Drive (1/2 Ht.) (LED located above diskette-slot)	72X8523
8	Blank Drive Bezel	72X7534
8	Diskette Drive Bezel (1/2 Ht.) (LED located below diskette-slot)	27F4175
	Drive A Cable (1/2 Ht.)	27F4916
	Drive B Cable (1/2 Ht.)	34F0001
	1.44MB Diskette Drive (1/3 Ht.)	64F0162
8	Diskette Drive Bezel (1/3 Ht.)	27F4230
	Drive A Cable (1/3 Ht.)	27F4912
	Drive B Cable (1/3 Ht.)	34F0000
	Diskette Drive Slide (1/3 Ht.)	27F4917
	20MB Hard Disk Drive	6128285
	30MB Hard Disk Drive	6128279
	170MB Hard Disk Drive	71G4958
	245MB Hard Disk Drive	61G3754
	420MB Hard Disk Drive	71G4930
	Terminator (for 6128279)	92F0269
	45MB Hard Disk Drive	92F0016
8	Hard Disk Drive Bezel	27F4177
	Hard Disk Drive Cable	27F4178

Model 33 (9533) Parts

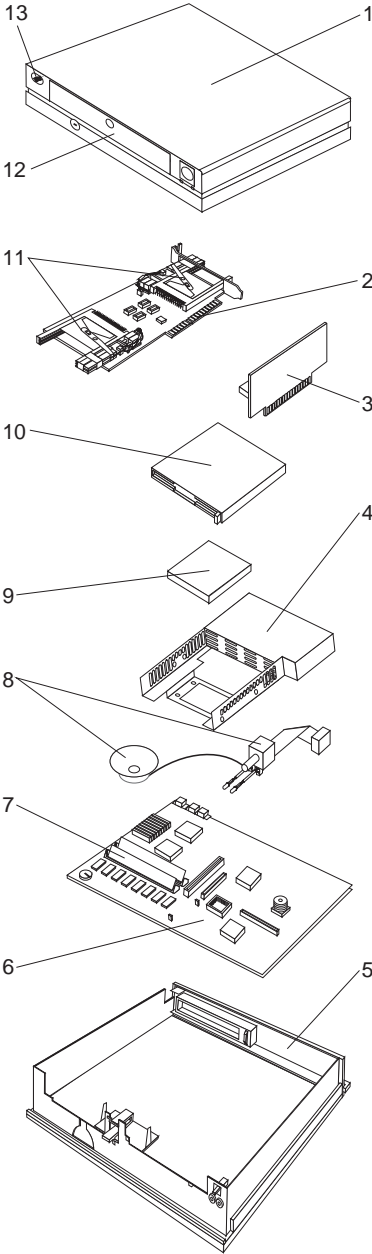

Index System Unit (33)

1	Top Cover	39G6572
	Key Lock	39G6577
	Floor Stand	91F1028
2	PCMCIA Adapter	40G1055
3	Riser Card	39G6435
4	Power Supply	39G6560
	Power Cord (US)	62X1045
5	Base Frame Assembly	39G6573
6	System Board	68G3034
	Coprocessor Socket	10G3975
	Diskette Drive Cable	39G6570
	Hard Disk Drive Cable	39G6571
	Battery	33F8354
7	4MB Memory Module Kit	92F0105
7	8MB Memory Module Kit	64F3606
8	Power Switch/Speaker Assembly	39G6576
11	PC Card Socket Assembly (Front or Rear)	71G2883
12	Door	39G6574
	Blank Drive Bezel	39G6578
	Blank Bezel	39G6580
	Blank Bezel (PCMCIA)	68G2549
13	Logo (R)	39G6579
	Miscellaneous Parts Kit	39G6575
	Token Ring Adapter (PC Card)	73G2048
DASD		
	5MB Solid State Hardfile	48G9899
	10MB Solid State Hardfile	48G9900
	15MB Solid State Hardfile	49G0000
	40MB Hard Disk Drive (PCMCIA)	92F0430
	105MB Hard Disk Drive (PCMCIA)	92F0429
	PCMCIA Hard Disk Drive Carrying Case	92F0430
9	120MB 2.5 in. Hard Disk Drive (IDE)	54G0135
9	170MB 2.5" Hard Disk Drive (IDE)	84G1193
9	340MB 2.5" Hard Disk Drive (IDE)	84G1195
10	1.44MB 3.5 in. Diskette Drive (w/ bezel)	49G2198
Keyboard & Mouse		
	Keyboard w/ Pointer	61G2901
	Num Key Pad	61G2903
	Num Key Pad Cable	1397482
	Mouse (New Style)	33G5420

Model 35 (8535) Parts

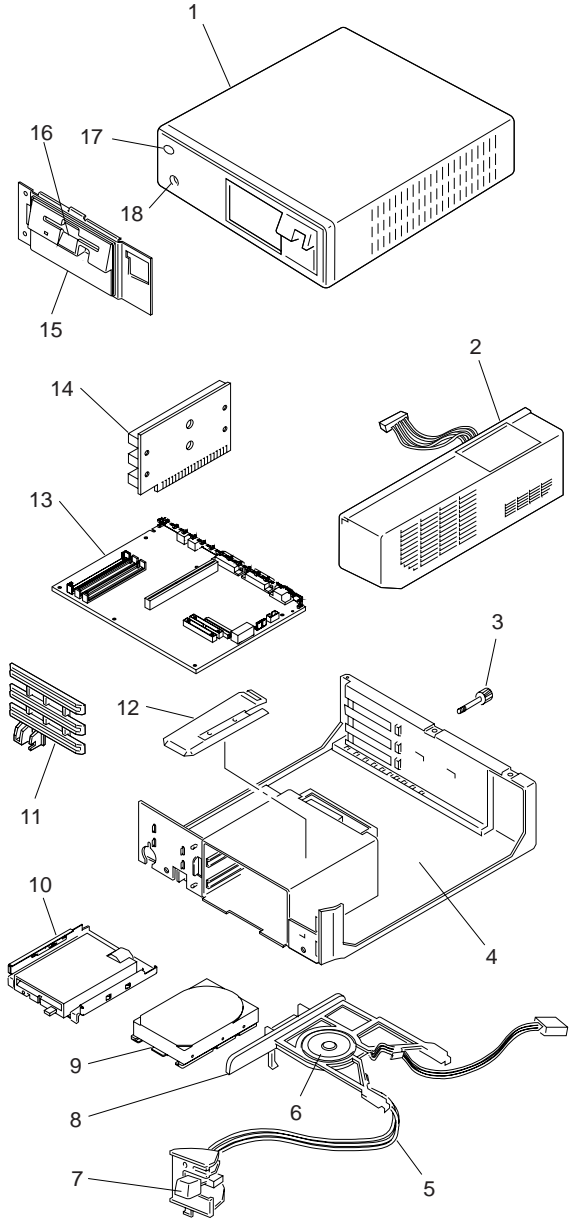

Index System Unit (35)

1	Top Cover Assembly	79F3448
2	Power Supply	79F3443
3	Cover Screw (Thumbscrew)	79F3463
4	Base Frame Assembly (R)	79F3449
4	Base Frame Assembly (R) (386SLC, 486SLC)	96F7781
	Rear Panel	79F3477
	Rear Panel (386 SLC, 486 SLC)	52G7918
	Cable Cover (386 SLC, 486 SLC)	96F7773
5	Control Assembly	79F3446
6	Speaker Assembly	79F3447
7	Power Switch Button	79F3460
8	Bus Adapter Support	79F3452
8	Bus Adapter Support (386 SLC, 486 SLC)	92F0239
11	Adapter Guide	79F3461
12	Cable Shield, Control Assembly	95F5607
12	Cable Shield, Control Assembly (386 SLC, 486 SLC)	96F7769
13	System Board (35 SX)	41G3948
13	System Board (35 SLC)	96F7506
13	System Board (35 386 SLC)	10G3966
13	System Board (35 486 SLC)	10G3976
	Real-Time Clock Module	8509237
	1MB Memory Module Kit (85ns)	90X8624
	2MB Memory Module Kit (85ns)	92F0104
	4MB Memory Module Kit	92F3337
	8MB Memory Module Kit (70ns)	64F3606
	8MB Memory Module Kit (80ns)	64F3607
14	Bus Adapter	79F3529
14	Bus Adapter (386 SLC, 486 SLC)	10G3967
15	Retainer Plate	79F3451
17	Front Cover Logo (R)	
	Model 35 SX	79F3457
	Model 35 LS	79F3478
	Model 35 SLC	06G9825
	Model 35 386 SLC	92F0238
	Model 35 486 SLC	52G9334
18	Cover Lock	92F0003
	Pawl (for 92F0003)	79F3459
	Floor Stand	79F3458
	Miscellaneous Parts Kit (see page 303)	79F3471

Index	DASD (35)	
10	1.44MB 3.5-Inch Diskette Drive	85F0050
10	2.88MB 3.5-Inch Diskette Drive	64F4148
10	2.88MB 3.5-Inch Diskette Drive (with electronic eject)	92F0132
	Bezel (Bay 1, for 92F0132)	92F0146
	Bezel (Bay 2, for 92F0132)	92F0133
16	3.5-Inch Diskette Drive Bezel (1/3 Ht.)	85F0093
	1.2MB 5.25-Inch Diskette Drive	64F4102
	Rail Kit (for 64F4102)	85F0041
16	5.25-Inch Blank Bezel (1/3 Ht.)	79F3450
16	5.25-Inch Diskette Drive Bezel (1/3 Ht.)	85F0068
	5.25-Inch Blank Bezel (1/2 Ht.)	85F0091
	Rewritable Optical Drive Bezel	92F0159
	Diskette Drive Cable	79F3453
	Diskette Drive Cable (386 SLC, 486 SLC)	96F7768
9	40MB Hard Disk Drive (ATA/IDE)	64F4132
9	80MB Hard Disk Drive (ATA/IDE)	64F4133
9	80MB Hard Disk Drive (ATA/IDE)	92F0152
9	104MB Hard Disk Drive (SCSI)	95F4748
9	170MB Hard Disk Drive (ATA/IDE)	95F4728
9	170MB Hard Disk Drive (ATA/IDE)	71G4958
9	212MB Hard Disk Drive (ATA/IDE)	93F0118
9	212MB Hard Disk Drive (SCSI)	95F4749
9	245MB Hard Disk Drive (ATA/IDE)	61G3754
9	245MB Hard Disk Drive (ATA/IDE)	92F0403
9	340MB Hard Disk Drive (ATA/IDE)	92F0404
9	420MB Hard Disk Drive (ATA/IDE)	71G4930
9	527MB Hard Disk Drive (ATA/IDE)	92F0405
	Hard Disk Drive Bezel	85F0091
	Hard Disk Drive Cable	79F3454
	Hard Disk Drive Cable (Double)	96F7780
	Hard Disk Drive Cable (Bay 3)	96F7776

Model 40 (8540) Parts

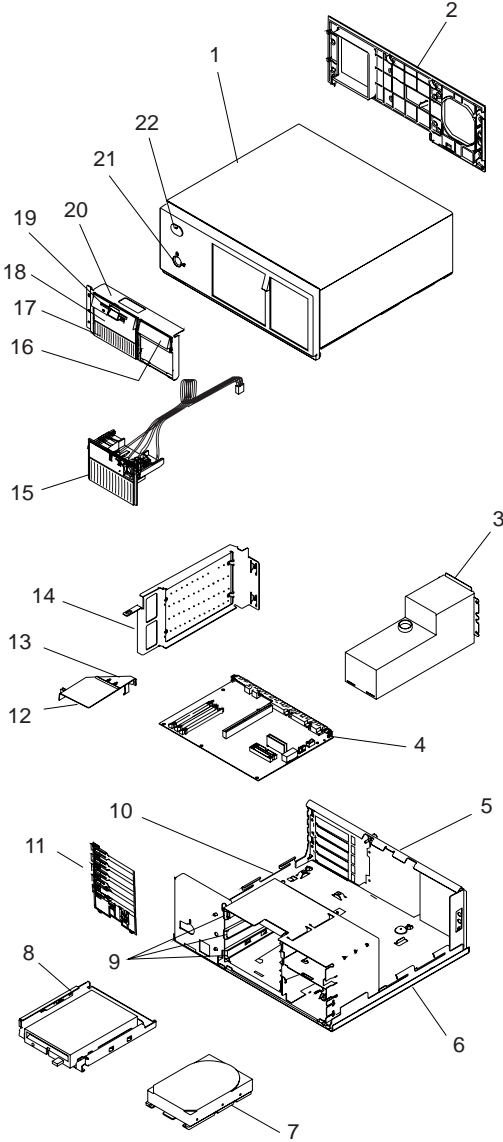

Index	System Unit (40)	
1	Top Cover Assembly (without lock)	96F7640
2	Rear Cover	85F0088
2	Rear Cover (386 SLC, 486 SLC)	92F0240
3	Power Supply	92F0058
4	System Board (40 SX)	41G3948
4	System Board (40 SLC)	96F7506
4	System Board (40 386 SLC)	10G3966
4	System Board (40 486 SLC)	10G3976
	Real-Time Clock Module	8509237
	1MB Memory Module Kit	90X8624
	2MB Memory Module Kit	92F0104
	4MB Memory Module Kit	92F3337
	8MB Memory Module Kit (70ns)	64F3606
	8MB Memory Module Kit (80ns)	64F3607
5	Rear Panel Assembly	92F0012
5	Rear Panel Assembly (386 SLC, 486 SLC)	92F0240
	Cable Cover (386 SLC, 486 SLC)	92F0248
6	Bottom Cover Assembly	85F0086
9	5.25-Inch Bay Drive Guides (2)	92F0014
10	Base Frame Assembly (R)	92F0011
11	Front Adapter Support Guide	92F0013
12	Air Baffle Hinged Cover	85F0084
13	Air Baffle Base	85F0087
14	Bus Adapter/Support Bracket	92F0107
14	Bus Adapter/Support Bracket (386 SLC, 486 SLC)	10G3969
15	Control Panel Assembly	92F0002
16	3.5-Inch Blank Bezel (Bay 4)	85F0092
	Bezel Insert (for 85F0092)	85F0095
17	5.25-Inch Louvered Bezel (Bay 3)	85F0094
	Bezel Insert (for 85F0094)	85F0096
18	5.25-Inch Blank Bezel (Bay 2)	85F0091
	Rewritable Optical Drive Bezel	92F0159
18	3.5-Inch Diskette Drive Bezel (Bay 2,3)	85F0003
18	5.25-Inch Diskette Drive Bezel (Bay 2,3)	85F0091
19	3.5-Inch Diskette Drive Bezel (Bay 1)	85F0093
20	Retainer Plate	85F0098
21	Cover Lock	92F0003
22	Front Cover Logo, 40 SX (R)	92F0001
22	Front Cover Logo, 40 SLC (R)	96F7507
22	Front Cover Logo, 40 386 SLC (R)	92F0241
22	Front Cover Logo, 40 486 SLC (R)	92F0275
	Pedestal	92F0000
	Miscellaneous Parts Kit (see page 303)	92F0015
	Shipping Carton	74F3571

<i>Index</i>	<i>DASD (40)</i>	
8	1.44MB 3.5-Inch Diskette Drive	85F0050
8	2.88MB 3.5-Inch Diskette Drive	64F4148
8	2.88MB 3.5-Inch Diskette Drive (with electronic eject)	92F0132
	Bezel (Bay 1, for 92F0132)	92F0146
	Bezel (Bay 2, for 92F0132)	92F0133
	1.2MB 5.25-Inch Diskette Drive	64F4102
	Rail Kit (for 64F4102)	85F0041
	Diskette Drive Cable	85F0089
7	40MB Hard Disk Drive (ATA/IDE)	64F4132
7	80MB Hard Disk Drive (ATA/IDE)	92F0152
7	104MB Hard Disk Drive (SCSI)	92F0152
7	170MB Hard Disk Drive (ATA/IDE)	95F4728
7	170MB Hard Disk Drive (ATA/IDE)	71G4958
7	212MB Hard Disk Drive (SCSI)	93F0118
7	245MB Hard Disk Drive (ATA/IDE)	61G3754
7	245MB Hard Disk Drive (ATA/IDE)	92F0403
7	340MB Hard Disk Drive (ATA/IDE)	92F0404
7	420MB Hard Disk Drive (ATA/IDE)	71G4930
7	527MB Hard Disk Drive (ATA/IDE)	92F0405
	Hard Disk Drive Cable	85F0090
	Hard Disk Drive Cable (Dual-Connector)	10G3972
	Hard Disk Drive Cable (Tri-Connector)	85F0090
	Hard Disk Drive Mounting Tray	64F0141

Model 50 (8550) Parts

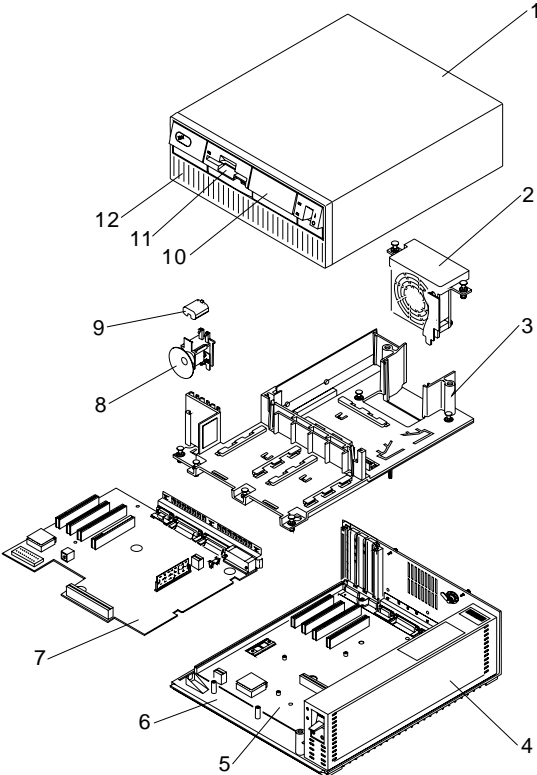

Index System Unit (50)

1	Top Cover	72X8501
2	Fan Assembly	72X8515
3	Support Structure	72X8504
4	Power Supply	90X9366
5	System Board (031, 061)	10G4005
6	System Base (031, 061) (R)	90X9534
6	System Base (021) (R)	72X8592
7	System Board (021)	72X8516
	Fuse, 3 Amp (System Board)	72X8561
	512KB Memory Module (021)	72X8517
	1MB Memory Module (031, 061)	90X8624
	2MB Memory Module (031, 061)	92F0104
	486SLC System Board Upgrade	61G3502
	2MB Memory Module Kit (for 61G3502)	92F0102
	4MB Memory Module Kit (for 61G3502)	92F0105
	8MB Memory Module Kit (for 61G3502)	64F3606
8	Battery/Speaker Assembly	33F5950
9	Battery	72X8498
10	Blank Drive Bezel	72X8531
11	Drive Bezel Kit	15F7571
12	Front Bezel/Logo (021) (R)	72X8502
12	Front Bezel/Logo (031, 061) (R)	15F7697
	Cover Lock Assembly	72X8512
	Cover Lock Kit	72X8577
	80287 Coprocessor	72X8528
	Label Kit	72X8509
	Misc. Parts Kit (System) (see page 302)	72X8525
	Misc. Parts Kit (Options) (see page 302)	72X8562
	Shipping Carton	72X8590

DASD (50)

1.44MB Diskette Drive	64F0207
(Includes Bezel and Drive Slide)	
1.44MB Diskette Drive Bus Adapter	72X8524
20MB Hard Disk Drive (021)	72X8522
20MB Hard Disk Drive Adapter (021)	72X8505
30MB Hard Disk Drive (031)	6128287
Slide (included in 90X8628)	
60MB Hard Disk Drive (061)	6128294
Hard Disk Drive Adapter (061)	90X9571
Hard Disk Drive Bus Adapter (061)	90X9441
160MB Hard Disk Drive	56F8895
Slide (included in 90X8628)	
Hard Disk Drive Slide Kit	90X8628
80MB Hard Disk Drive (ATA/IDE)	54G0160
170MB Hard Disk Drive (ATA/IDE)	95F4728
245MB Hard Disk Drive (ATA/IDE)	92F0403
340MB Hard Disk Drive (ATA/IDE)	92F0404
Hard Disk Drive Ribbon Cable	71G2683
(for 95F4728, 92F0403, 92F0404)	
Hard Disk Drive Power Cable	71G2684
(for 95F4728, 92F0403, 92F0404)	

Model 53 (9553) Parts

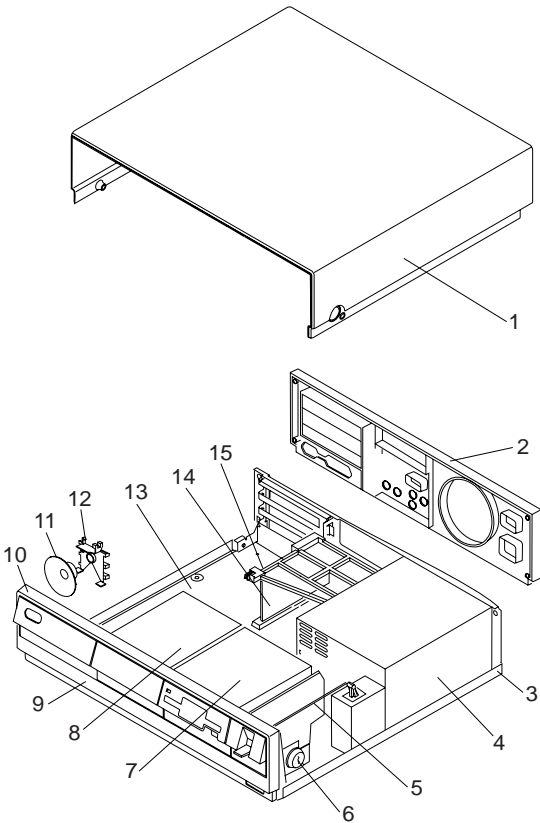

Index System Unit (9553-xBx)

1	Top Cover	27F4172
2	Rear Cover	27F4670
3	Base Frame	71G2671
	Rubber Feet	61X8917
4	Power Supply	27F4166
5	Power Switch Link	27F4168
6	Key Lock	27F4169
	Parity Memory Module Kits:	
	2MB (70ns)	92F0102
	4MB (70ns)	92F0105
	8MB (70ns)	64F3606
7	1.44MB Diskette Drive Assembly	71G2673
	Diskette Drive Cable	71G2670
	Blank Bezel	82G1791
8	120MB Hard Disk Drive	92F0256
8	250MB Hard Disk Drive	61G3754
	Hard Disk Drive Data Cable	71G2664
	Hard Disk Drive Power Cable	71G2684
	Hard Disk Drive LED	71G2668
	Hard Disk Drive LED Holder	71G2672
9	Blank Bezel, Bottom	71G2669
10	Front Cover w/o Logo	71G2665
	PS/2 53 Logo	71G2666
	PS/2 53LS Logo	71G2667
11	Speaker	27F4672
12	Speaker Guide	27F4673
13	System Board	71G5955
	System Board Clip	61X8933
	Real Time Clock Module	06H3013
14	Riser Card	27F4666
15	Riser Card Bracket	27F4674
	Ethernet Adapter	92F0046
	Token Ring Adapter	74F9415
	Miscellaneous Parts Kit:	27F4171
	Nut (2)	
	Cover screw (2)	
	I/O panel screw (2)	
	3.5mm captive screw (2)	
	Fingerstock shield (3)	
	Fingerstock base shield (3)	
	Slide (1)	
	Standoff shaft (2)	
	3mm screw (5)	
	Ground power special bracket (1)	

Model 55 (8555) SX Parts

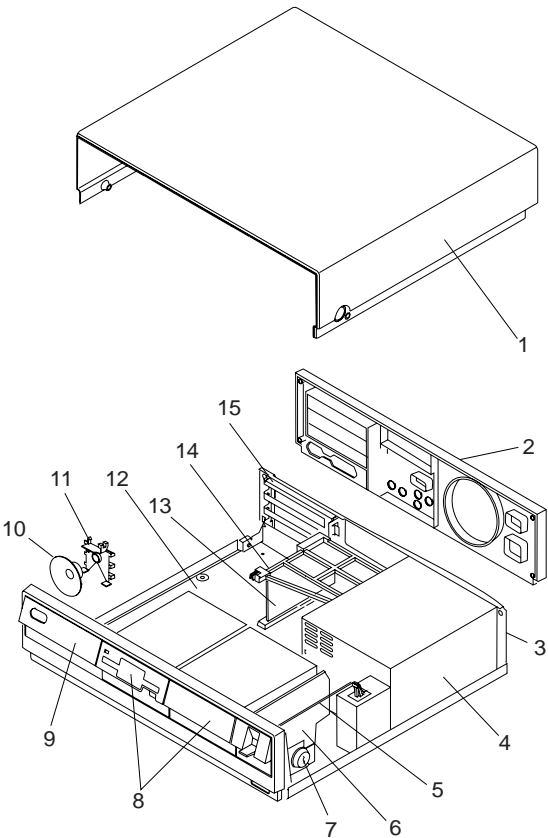

Index	System Unit (55 SX)	
1	Top Cover	27F4172
2	Rear Cover	27F4670
3	Base Frame Assembly (R)	27F4167
4	Power Supply/Fan Assembly	27F4166
5	Power Switch Link	27F4168
6	Drive Cradle	27F4170
7	Keylock Assembly	27F4169
8	(see DASD)	
9	Front Cover with Logo (R) (55 SX)	27F4677
9	Front Cover with Logo (R) (55 LS)	33F8230
10	Speaker	27F4672
11	Speaker/Adapter Guide (no speaker)	27F4673
12	System Board (55 SX)	27F4667
12	System Board (55 LS, LTO, LE0)	57F3003
	Fuse, 3 Amp (System Board)	72X8561
	Real-Time Clock Module	8509237
	2KB NV-RAM Module	64F0722
	1MB Memory Module Kit	90X8624
	2MB Memory Module Kit	92F0104
	4MB Memory Module Kit	92F3337
	80387SX Math Coprocessor, 16 MHz	33F8160
	486SLC System Board Upgrade	71G2602
	2MB Memory Module Kit (for 61G3502)	92F0102
	4MB Memory Module Kit (for 61G3502)	92F0105
	8MB Memory Module Kit (for 61G3502)	64F3606
13	Bus Adapter (55 LS)	64F3732
13	Bus Adapter (55 SX)	27F4666
14	Bus Adapter Support	27F4674
15	Adapter Support Panel	27F4671
	Adapter Bracket	27F4674
	Drive Grounding Bracket	33F8156
	Miscellaneous Parts Kit (see page 301)	27F4171
	Shipping Carton	83X9431

Index DASD (55 SX)

	1.44MB Diskette Drive (1/3 Ht.)	64F0162
	Diskette Drive Slide (for 64F0162)	64F0156
8	Diskette Drive Bezel	27F4230
8	Blank Bezel	72X7534
	Drive A Cable	27F4912
	Drive B Cable	34F0000
	30MB Hard Disk Drive (DBA)	64F4146
	40MB Hard Disk Drive (DBA)	56F8896
	60MB Hard Disk Drive (DBA)	85F0049
	80MB Hard Disk Drive (DBA)	56F8892
	160MB Hard Disk Drive (DBA)	56F8893
8	Hard Disk Drive Bezel (30MB, 40MB)	27F4177
8	Hard Disk Drive Bezel (60MB, 80MB, 160MB)	27F4675
	Hard Disk Drive Cable	27F4669
	80MB Hard Disk Drive (ATA/IDE)	54G0160
	170MB Hard Disk Drive (ATA/IDE)	71G4958
	170MB Hard Disk Drive (ATA/IDE)	95F4728
	245MB Hard Disk Drive (ATA/IDE)	61G3754
	245MB Hard Disk Drive (ATA/IDE)	92F0403
	340MB Hard Disk Drive (ATA/IDE)	92F0404
	420MB Hard Disk Drive (ATA/IDE)	71G4930
	Hard Disk Drive Ribbon Cable (for 95F4728, 92F0403, 92F04040)	71G2662
	Hard Disk Drive Power Cable (for 95F4728, 92F0403, 92F04040)	71G2684
	Original Hard Disk Drive Cable	27F4669

Model 56 (8556) Parts

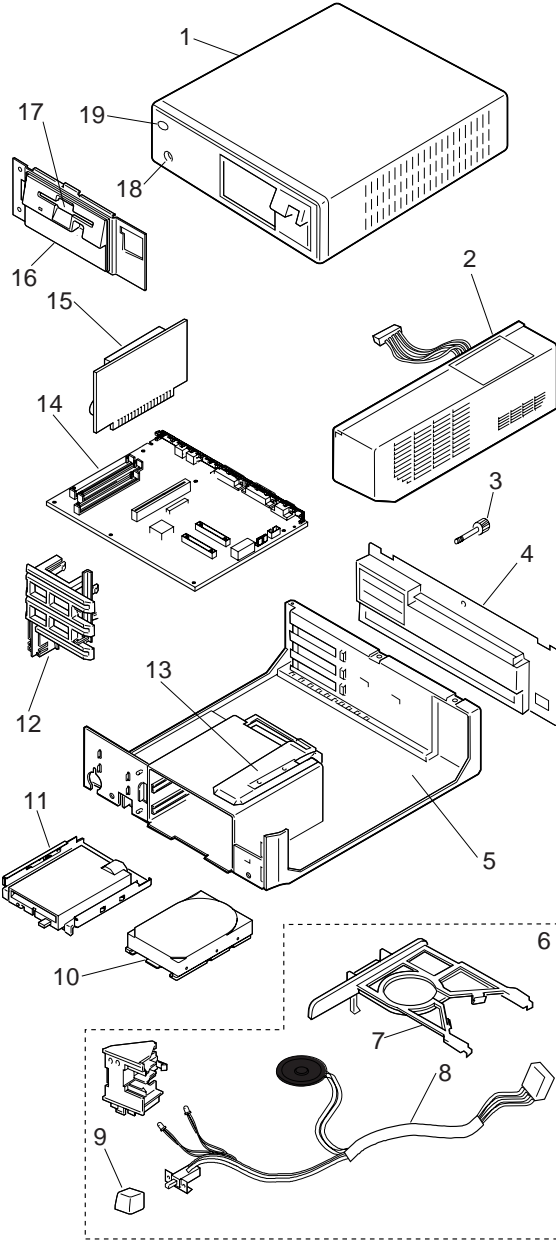

Index System Unit (56)

1	Top Cover Assembly (without lock)	79F3448
2	Power Supply	79F3443
3	Cover Screw (Thumbscrew)	79F3463
4	Rear Panel	79F7208
5	Base Frame Assembly (R)	79F7212
6	Control Assembly	95F6018
7	Bus Adapter Support	79F7213
8	Speaker Assembly	79F3447
9	Power Switch Button	79F3460
12	Adapter Card Guide	79F7218
13	Cable Shield, Control Assembly	95F5607
14	System Board 20 MHz (no memory):	
	56 SX, 56 LS	84F7994
	56 SLC, 56 SLC LS	85F0298
	2MB Memory Module Kit (70ns)	92F0102
	4MB Memory Module Kit (70ns)	92F0105
	8MB Memory Module Kit (70ns)	64F3606
	Processor Options	
	386SLC	92F0078
	486SLC2	10G7103
	486SLC3 60/20MHz	61G2099
15	Bus Adapter (with battery)	79F7210
	Battery	33F8354
16	Retainer Plate	07G2858
17	3.5-inch Diskette Drive Bezel (1/3 Ht.)	85F0093
	5.25-inch Blank Bezel (1/3 Ht.)	79F3450
	5.25-inch Blank Bezel (1/2 Ht.)	85F0091
	5.25-inch Diskette Drive Bezel (1/2 Ht.)	85F0068
18	Cover Lock Assembly	92F0003
	Pawl (required for 92F0003)	79F3459
19	Front Cover Logo (R):	
	56 SX	79F7216
	56 LS	79F7217
	56 SLC	06G6607
	56 SLC LS	00G6609
	Floor Stand	79F3458
	Cable Cover	79F3462
	Miscellaneous Parts Kit (see page 303)	79F7209

Index DASD (56)

11	1.44MB 3.5-Inch Drive	85F0050
11	2.88MB 3.5-Inch Drive	64F4148
11	2.88MB 3.5-Inch Diskette Drive (with electronic eject)	92F0132
	Bezel (Bay 1, for 92F0132)	92F0146
	Bezel (Bay 2, for 92F0132)	92F0133
	3.5-Inch Diskette Drive Tray	85F0097
	1.2MB 5.25-Inch Diskette Drive	64F4102
	Rail Kit (for 64F4102)	85F0041
	Diskette Drive Cable	07G2857
10	40MB Hard Disk Drive (SCSI)	56F8866
	60MB Hard Disk Drive (SCSI)	6128296
	80MB Hard Disk Drive (SCSI)	56F8854
	104MB Hard Disk Drive (SCSI)	95F4748
	120MB Hard Disk Drive (SCSI)	6128298
	160MB Hard Disk Drive (SCSI)	56F8851
	212MB Hard Disk Drive (SCSI)	95F4749
	540MB Hard Disk Drive (SCSI)	92F0406
	1GB Hard Disk Drive (SCSI)	92F0428
	Hard Disk Drive Cable	79F7214

Model 57 (8557) Parts

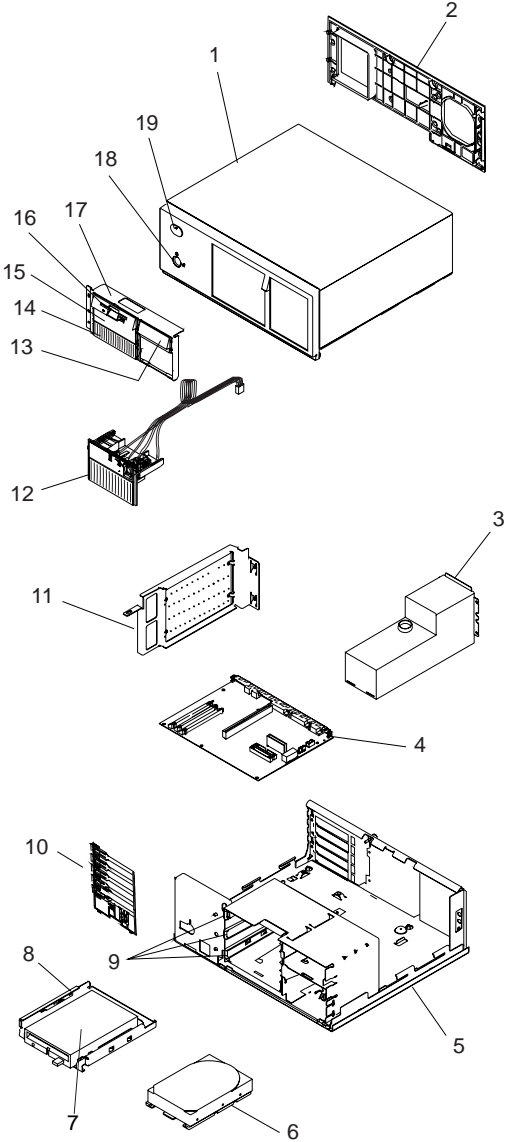

Index	System Unit (57)	
1	Top Cover Assembly (without lock)	96F7640
2	Rear Panel Cover	92F0035
3	Power Supply (197 Watt)	92F0058
4	System Board (57 SX)	84F7994
4	System Board (57 SLC, M57 SLC)	85F0298
	Processor Options	
	386SLC	92F0078
	486SLC2	10G7103
	486SLC3 60/20MHz	61G2099
	2MB Memory Module Kit (70ns)	92F0102
	4MB Memory Module Kit (70ns)	92F0105
	8MB Memory Module Kit (70ns)	64F3606
5	Frame Assembly (R):	
	Type 1 (57 SX, 57 SLC)	92F0138
	Type 2 (M57 SLC)	92F0040
6	(see DASD)	
7	(see DASD)	
8	Drive Tray for 3.5-Inch Drive (Bays 1,2,3)	85F0097
9	5.25-Inch Bay Drive Guides (2)	92F0014
10	Front Adapter Support Guide	92F0042
11	Bus Adapter with Battery	
	Type 1 (mounting tab, early 8557 only)	85F0056
	Type 2 (2 mounting holes, later 57 & all M57)	41G3877
	Battery (3V Lithium)	33F8354
12	Control Panel Assembly (57 SX, 57 SLC)	
	(with speaker, power switch, cable)	92F0002
12	Control Panel Assembly (M57 SLC)	
	Control Panel Assembly	92F0109
	(with speaker and power switch)	
	Cable to System Board	92F0111
	Interposer (for connector P2)	92F0110
	Cable to ACPA/A	92F0113
13	3.5-Inch Blank Bezel (Bay 4)	85F0092
	Bezel Insert for 85F0092	85F0095
14	5.25-Inch Louvered Bezel (Bay 3)	85F0094
	Bezel Insert for 85F0094	85F0096
	Air Baffle - Fixed Disk Drive Bay 4C	92F0251
15	5.25-Inch Blank Bezel (Bay 2)	85F0091
15	3.5-Inch Diskette Drive Bezel (Bay 2,3)	85F0003
15	5.25-Inch Diskette Drive Bezel (Bay 2,3)	64F4125
15	CD-ROM Drive Bezel (Bay 2,3)	85F0008
	Rewritable Optical Drive Bezel	92F0159
16	3.5-Inch Diskette Drive Bezel (Bay 1)	85F0093
17	Retainer Plate	85F0098
18	Cover Lock	92F0003
19	Logo, 57 SX (R)	92F0037
19	Logo, 57 SLC (R)	92F0136
19	Logo, M57 SLC (R)	92F0137
	Pedestal	92F0000
	Miscellaneous Parts Kit (see page 303)	92F0015
	Shipping Carton	74F3571

Index DASD (57)

7	1.44MB Diskette Drive/Tray	85F0050
7	2.88MB Diskette Drive/Tray	64F4148
7	2.88MB 3.5-Inch Diskette Drive (with electronic eject)	92F0132
	Bezel (Bay 1, for 92F0132)	92F0146
	Bezel (Bay 2, for 92F0132)	92F0133
	Diskette Drive Signal Cable	85F0089
6	60MB Hard Disk Drive (SCSI)	6128296
6	80MB Hard Disk Drive (SCSI)	56F8854
6	104MB Hard Disk Drive (SCSI)	95F4748
6	120MB Hard Disk Drive (SCSI)	6128298
6	160MB Hard Disk Drive (SCSI)	56F8851
6	212MB Hard Disk Drive (SCSI)	95F4749
6	320MB Hard Disk Drive (SCSI)	85F0011
6	400MB Hard Disk Drive (SCSI)	85F0012
6	540MB Hard Disk Drive (SCSI)	92F0406
6	1GB Hard Disk Drive (SCSI)	92F0428
	Hard Disk Drive Cable (57 SX, 57 SLC)	92F0036
	Hard Disk Drive Cable (57 SLC)	96F7649
	Hard Disk Slide	96F7775

Cached Processor Option (57)

	Cached Processor Option (with IBM386 SLC) (P1 label attached near system serial number)	92F0078
	486SLC2 Processor Option	10G7103

Note: When you replace the system board in a system with a Cached Processor Option, you must first remove the math coprocessor socket from the 11 x 11 connector on the new system board.

Model 60 (8560), 65 (8565), and 80 (8580) Parts

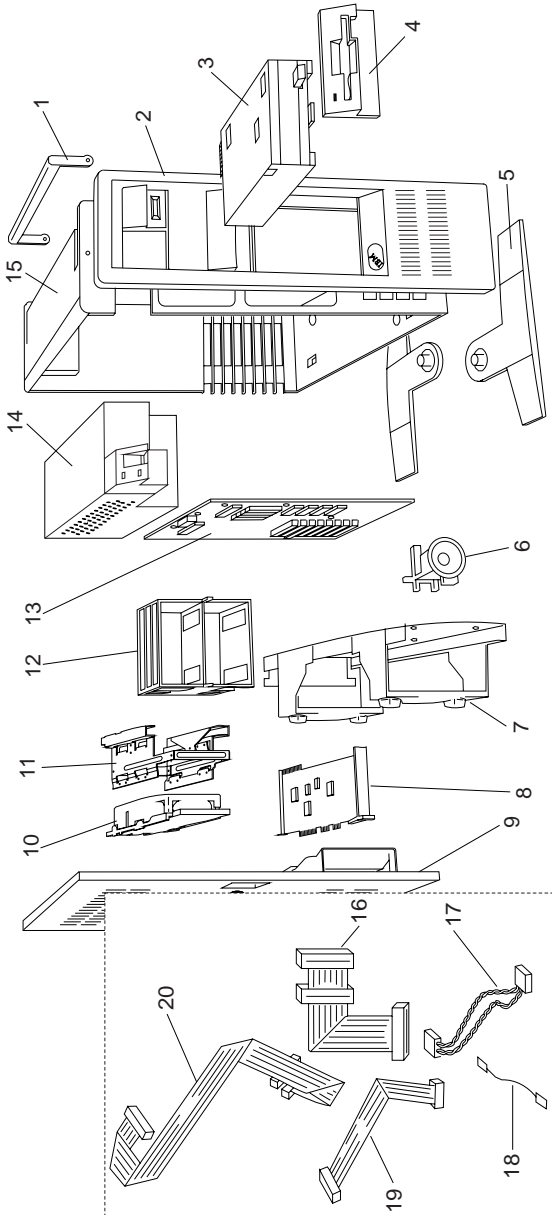

Index	System Unit (60, 65, 80)	
1	Handle	72X8569
2	Front Bezel/Logo (R)	72X8549
3	(see DASD)	
4	1/2 Ht. Diskette-Drive Bezel	72X8550
4	1/3 Ht. Diskette-Drive Bezel	34F0030
	Blank Bezel for Diskette Drive	72X8535
	5.25-Inch Diskette Drive Bezel	15F7915
	5.25-Inch CD-ROM Drive	00G1959
	Blank Bezel for 5.25-Inch Drive Bay	72X8560
	Rewritable Optical Drive Bezel	92F0156
	5.25-Inch CD-ROM Bezel (for 00G1959)	34F0044
5	Base Foot	72X8565
6	Battery/Speaker Assembly	33F5950
6	Battery/Speaker Assembly (8565)	57F1437
	Battery	72X8498
7	Hard Disk Drive Support Structure	72X8527
	Rear Mounting Plate (for 72X8527)	72X8563
8	Adapter	
	See "Options and Adapters Matrix" on page 311.	
9	Cover (8580-311)	15F6801
9	Cover (8565 All Models)	64F0160
9	Cover (All Others)	72X8548
	Cover-Lock Assembly	72X8557
	Cover-Lock Kit	72X8572
10	(see DASD)	
11	Hard Disk Drive Slide Tray (SCSI)	34F0031
12	Drive Support Structure (1/2 Ht. Drive)	72X8559
12	Drive Support Structure (1/3 Ht. Drive)	34F0032
13	System Board 10MHz (8560)	72X8538
	256KB Memory Kit (for 72X8538)	61X8906
13	System Board 16MHz (8565)	92F0800
	2MB Memory Kit (for 92F0800)	92F0104
	4MB Memory Kit (for 92F0800)	92F3337
	Real Time Clock Module	8509237
	2KB NV-RAM Module	64F0722
13	System Board 16MHz (8580-041, 071)	33F8416
	1MB Memory Kit (for 33F8416)	72X6670
13	System Board 20MHz (8580-081, 111, 121, 161, 311, 321)	10G4148
	2MB Memory Kit (for 92F0756)	92F0669
13	System Board 25MHz (8580-A21, A31, A61)	85F0046
	4MB Memory Kit (for 85F0046)	92F0106
	Fuse 3A, System Board (8560, 8580)	72X8561
	Math Coprocessors:	
	16 MHz (041, 071)	72X6673
	20 MHz (081,111,121,161,311,321)	90X7393
	25 MHz (A21, A31, A61)	15F7661
	486DX33 Processor Upgrade	92F0437
14	Power Supply (All Models)	57F1600
15	System Base (8560) (R)	72X8593
15	System Base (8565) (R)	64F0159
15	System Base (8580) (R)	64F0158
	Label Kit	72X6674
	Misc. Parts Kit (System) (see page 302)	72X8578
	Misc. Parts Kit (Options) (see page 302)	72X8579
	Misc. Parts Kit (Memory) (see page 302)	72X7037
	Misc. Parts Kit (Hardware Kit) (see page 302)	72X8580
	Shipping Carton	72X8591

Index DASD (60, 65, 80)

3	1.44MB (1/2 Ht.) Diskette Drive	72X8523
	Diskette Drive Slide (for 72X8523)	72X8507
3	1.44MB (1/3 Ht.) Diskette Drive	64F0162
	Diskette Drive Slide (for 64F0162)	64F0156
10	44MB Hard Disk Drive (ST506)	72X8541
	(8560-041, 8580-041 only)	
	Fixed Disk Adapter (ST506)	72X8540
	(8560-041, 8580-041 only)	
10	70MB Hard Disk Drive (ESDI)	72X8519
10	115MB Hard Disk Drive (ESDI)	90X7392
10	314MB Hard Disk Drive (ESDI)	90X8745
	Fixed Disk Adapter (ESDI)	92F0061
10	60MB Hard Disk Drive (SCSI)	6128296
10	80MB Hard Disk Drive (SCSI)	56F8854
10	120MB Hard Disk Drive (SCSI)	6128298
10	160MB Hard Disk Drive (SCSI)	56F8851
10	320MB Hard Disk Drive (SCSI)	85F0011
10	400MB Hard Disk Drive (SCSI)	85F0012
10	540MB Hard Disk Drive (SCSI)	92F0406
10	1GB Hard Disk Drive (SCSI)	92F0428

Index DASD Cables (60, 65, 80)

16	1/3 Ht. Diskette Drive Cable	34F0036
16	1/2 Ht. Diskette Drive Cable	72X8543
	Drive-Cable Retainer (1/2 Ht. Drive)	72X8573
17	Power Cable (single)	72X8521
17	Power Cable (dual)	34F0034
18	Hard Disk Drive Ground Wire, see Misc. Parts Kit (System)	
19	1.2MB Internal Cable (for 15F6912)	15F6914
19	Signal Cable Drive C (except SCSI)	72X8545
19	Signal Cable Drive D (except SCSI)	72X8567
20	Control Cable (except SCSI)	72X8542
20	SCSI Signal Cable (Two Connector)	64F0154
20	SCSI Signal Cable (Three Connector)	34F0035
20	SCSI Signal Cable (Four Connector)	64F0155

Model 70 (8570) Parts

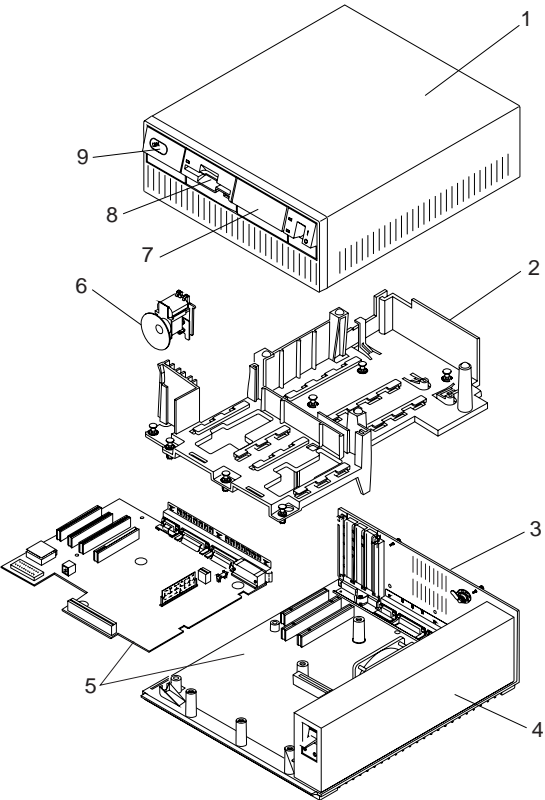

Index	System Unit (70)	
1	Top Cover	90X9288
2	Support Structure	90X9289
3	16 MHz Base Frame Assemblies (E61)	
	S/N 1500000 to 1999999, 2500000 to 2511499, 4000000 to 4499999, 7000000 to 7143999	90X9351
	S/N 2511500 to 2650000, 7144000 to 7999999, DT5500A0001 to DT5500Z9999 23HBLTH to 23HXATL	33F6065
3	20 MHz Base Frame Assemblies (061,081,121,161)	
	S/N 500000 to 999999, 3500000 to 3999999, 5500000 to 5505499, 8000000 to 8006999, 9000000 to 9062999	90X9408
	S/N 5505500 to 5605500, 8007000 to 8999999, 9063000 to 9999999, CF5500AA001 to CF5500ZZ999 23HXATM to 23KGVYA, 23KGVYK to 23LFGHC,	33F6064
3	25 MHz, 80386 Base Frame Assembly	15F8237
3	25 MHz, 80486 Base Frame Assembly	64F0134
4	Power Supply/Fan Assembly	90X8626
5	See System Boards	
6	Battery/Speaker Assembly (with attached cable)	33F5950
7	Blank Drive Bezel	72X8531
	Cover Lock Assembly	72X8512
	Cover Lock Kit	72X8577
8	Drive Bezel Kit	15F7571
9	Front Bezel/Logo (R)	15F7510
	Battery	72X8498
	1MB Memory Module Kit (16 or 20 MHz)	90X8624
	2MB Memory Module Kit (16 or 20 MHz)	92F0104
	2MB Memory Module Kit (25 MHz)	92F0103
	80387 Coprocessor (16 MHz)	72X6673
	80387 Coprocessor (20 MHz)	90X7393
	80387 Coprocessor (25 MHz) (80386 only)	15F7661
	System Boards (70)	
	Model E61, 16 MHz System Board	
	S/N 1500000 to 1999999, 2500000 to 2511499, 4000000 to 4499999, 7000000 to 7163999	96F7309

System Unit (70) (continued)**Model E61, 16 MHz System Board**

S/N 2511500 to 2650000, 7144000 to 7999999, DT5500A0001 to DT5500Z9999, F001000 to F249999, AAAAA to ABLTG, BBBBB to BCMVH	41G3984
---	---------

Model E81, 16 MHz System Board

System Board	41G3984
--------------	---------

Models 061, 121, 20 MHz System Board

S/N 500000 to 999999, 3500000 to 3999999, 5500000 to 5505499, 8000000 to 8006999, 9000000 to 9075499	96F7308
--	---------

Models 061, 121, 20 MHz System Board

S/N 5505500 to 5605500, 8007000 to 8999999, 9075500 to 9999999, CF5500AA001 to CF5500ZZ999	41G3985
---	---------

Models 081, 161, 20 MHz System Board

System Board	41G3985
--------------	---------

25-MHz System Board

Processor Board Standoffs (4)	15F7660
-------------------------------	---------

Models A81, A61, A21, A16,**80386 System Board Assembly**

System Board	92F0580
Processor Board	15F7659

Models B81, B61, B21, B16,**80486 System Board Assembly**

System Board	41G3979
Processor Board	64F0123
Processor Board Removal Tool (for 64F0123)	57F2859

486DX33 Processor Upgrade

486DX33 Processor Upgrade Board	92F0436
Coprocessor Compatibility Plug	
Socket Extender	

Fuse, 3 Amp (All System Boards)

Fuse, 3 Amp (All System Boards)	72X8561
Label Kit	72X8509
Snap Kit	72X8526
Misc. Parts Kit (System) (see page 302)	72X8525
Misc. Parts Kit (Options) (see page 302)	72X8562
Shipping Carton	72X8590

DASD (70)

Hard Disk/Diskette Drive Bus Adapter	90X9287
1.44MB Diskette Drive (includes bezel)	64F0207
Diskette Drive Slide	72X8507

Note: The following hard disk drives include the ESDI hard disk drive controller and slides.

60MB Hard Disk Drive (DBA)	6128294
80MB Hard Disk Drive (DBA)	56F8894
Terminator (for 56F8894)	92F0269
120MB Hard Disk Drive (DBA)	6128291
160MB Hard Disk Drive (DBA)	56F8895
Hard Disk Drive Slide Kit	90X8628

Models 56, 76 (9556, 9576) Parts

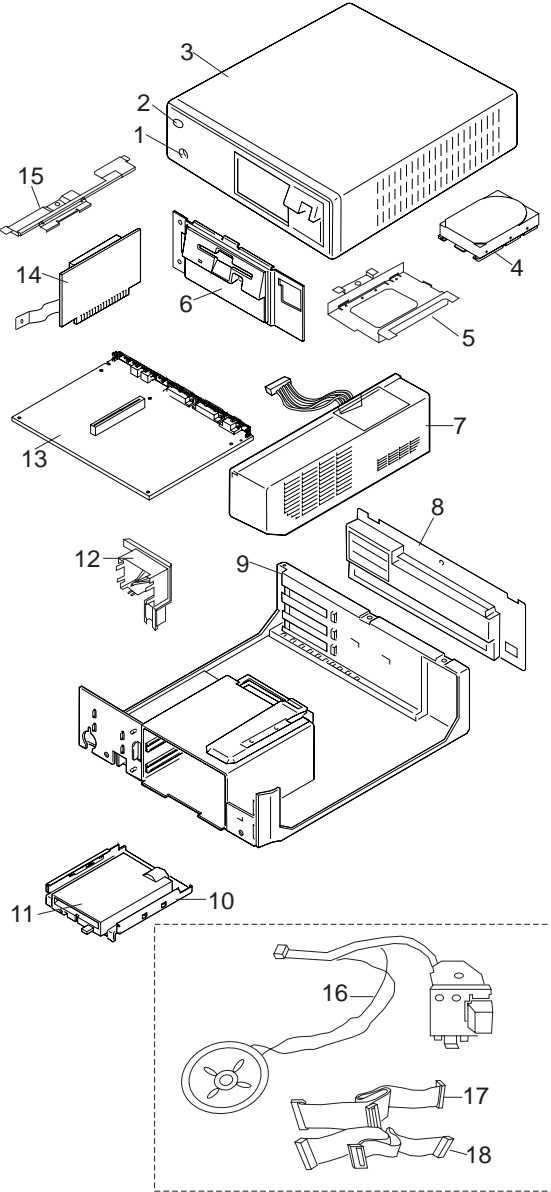

Index	System Unit (9556, 9576)	
1	Cover Lock Assembly	92F0003
	Pawl (required for 92F0003)	79F3459
2	Front Cover Logo (R)	
	9576 (PS/2 76 486)	92F0245
	9576 (PS/2 76 486DX2)	92F0408
	9556 (PS/2 56 486SLC2)	96F7770
	9556 (PS/2 56LS 486SLC2)	96F7771
3	Top Cover Assembly (no lock)	92F0252
3	Top Cover Assembly (no lock), for models:	73G6059
	56 with S/N YCW00 to YNR99 and YNT00 to YZN99	
	76 with S/N ATXDA to AXATL	
	Cover Screw (Thumbscrew)	79F3463
4	(see DASD)	
5	Hard Disk Shelf	96F7776
6	Retainer Plate	33G8423
7	Power Supply (118 Watt)	79F3443
8	Rear Panel (9576)	52G7917
8	Rear Panel (9556)	52G7916
9	Base Frame Assembly (R)	96F7767
9	Base Frame Assembly (R) for models:	73G6062
	56 with S/N YCW00 to YNR99 and YNT00 to YZN99	
	76 with S/N ATXDA to AXATL	
	Front Shield	73G6061
	EMI Shield	73G6064
	EMI Clip	73G6065
	Cable Shield (top of bay)	95F5607
	Tamper-Resistant Rear Cable-locking	
	Cover Assembly (option)	96F7773
10	(see DASD)	
11	(see DASD)	
12	Card Guide/Speaker Bracket (9576)	92F0244
12	Adapter Guide/Tamper-Evident	
	Switch Assembly (9556)	92F0243
13	System Boards (no memory)	
	486SLC2-25/50 MHz (9556)	39G6407
	486SLC3-33/66 MHz (9556)	81G1658
	486SLC3-33/66 MHz (9556LS)	81G1660
	486SLC3-25/75 MHz (9556)	65G8615
	486SX-33 MHz,	39G2668
	for non-UltiMedia systems only (9576)	
	486SX-33 MHz (9576)	39G5698
	486DX2-33/66 MHz, for	39G2669
	non-UltiMedia systems only (9576)	
	486DX2-33/66 MHz (9576)	39G6086
	Optional Microprocessors	
	P23T-25/50 MHz	92F0147
	P23T-33/66 MHz	92F2582
	2MB Memory Module Kit (70ns)	92F0102
	4MB Memory Module Kit (70ns)	92F0105
	8MB Memory Module Kit (70ns)	64F3606
	Math Coprocessor Socket	10G3975
14	Bus Adapter (with battery) (9556)	79F7210
14	Bus Adapter (with battery) (9576)	87F4833
	Battery	33F8354
15	Bus Adapter Support	96F7777

Index	System Unit (9556, 9576)	
16	Control Assembly	96F7769
	(Power Switch, Cable, Speaker)	
	Power Switch Button only	79F3460
	Audiovation Adapter	65G8863
	Floor Stand	79F3458
	Miscellaneous Parts Kit	79F7209
	Plastic Screw (1)	
	Steel screws (6)	
	I/O brackets (3)	
	Rubber Feet (4)	
	Clip (1)	
Index	DASD (9556, 9576)	
10	Diskette Drive Tray	85F0097
11	1.44MB 3.5-Inch Diskette Drive	85F0050
11	2.88MB 3.5-Inch Diskette Drive	64F4148
11	2.88MB 3.5-Inch Diskette Drive	92F0132
	(with electronic eject)	
	Bezel (Bay 1, for 92F0132)	92F0146
	Bezel (Bay 2, for 92F0132)	92F0133
	3.5-inch Bezel (Bay 1, for 73G6059)	73G6067
	5.25-inch Bezel (Bay 1, for 73G6059)	73G6068
	5.25-inch Bezel (Bay 2, for 73G6059)	73G6069
	Rewritable Optical Drive Bezel	92F0159
	DASD Guides for Drive Bays	92F0014
	1.2MB 5.25-Inch Diskette Drive	64F4102
	Rail Kit (for 64F4102)	85F0041
	(left/right rails, screws)	
	3.5-Inch Diskette Drive Bezel (Bay 1)	85F0093
	3.5-Inch Diskette Drive Bezel (Bay 2)	85F0003
	5.25-Inch Blank Bezel (Bay 1)	79F3450
	5.25-Inch Blank Bezel (Bay 2)	85F0091
	5.25-Inch Diskette Drive Bezel (Bay 2)	64F4125
4	40MB Hard Disk Drive (SCSI)	56F8866
4	60MB Hard Disk Drive (SCSI)	6128296
4	80MB Hard Disk Drive (SCSI)	56F8854
4	104MB Hard Disk Drive (SCSI)	95F4748
4	170MB Hard Disk Drive (SCSI)	71G6550
4	212MB Hard Disk Drive (SCSI)	95F4749
4	245MB Hard Disk Drive (SCSI)	71G4875
4	340MB Hard Disk Drive (SCSI)	71G6551
4	540MB Hard Disk Drive (SCSI)	92F0406
4	540MB Hard Disk Drive (SCSI)	61G3788
4	1GB Hard Disk Drive (SCSI)	92F0428
	600MB CD-ROM (SCSI)	92F0084
17	Hard Disk Cable	96F7766
18	Diskette Drive Cable	96F7768

Models 57, 77, M57, M77 (9557, 9577)
Parts

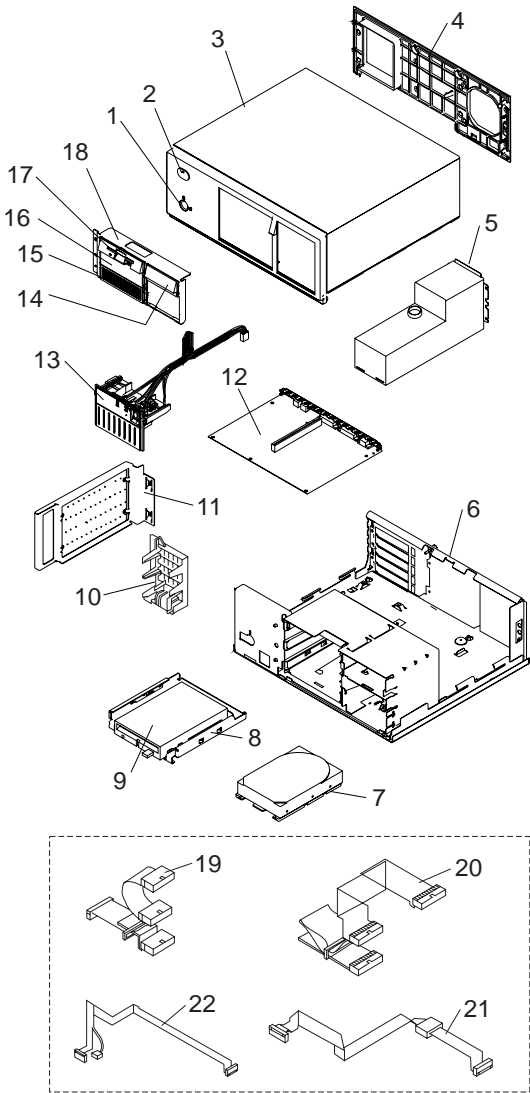

Index	System Unit (9557, 9577)	
1	Cover Lock	92F0003
2	Front Cover Logo (R)	
	PS/2 77 486	92F0249
	PS/2 77 486DX2	92F0272
	PS/2 M77 486	92F0250
	PS/2 M77 486DX2	92F0250
	PS/2 57 486SLC2	96F7763
	PS/2 M57 486SLC2	96F7764
3	Top Cover Assembly (without lock)	96F7640
4	Rear Panel Cover	92F0247
	Cover Assembly, Cable-Locking (option)	92F0248
4	Rear Panel Cover (DV Model)	96F7755
5	Power Supply (197 Watt)	92F0058
6	Frame Assembly (R)	92F0138
	Cover (for underside of frame)	85F0086
	I/O Slot Assembly (rear of frame)	10G3971
7	(see DASD)	
8	(see DASD)	
9	(see DASD)	
10	Adapter Guide and Tamper- Evident Switch Assembly (9557)	96F7758
10	Adapter Guide (9577)	92F0042
11	Bus Adapter (9577)(with battery)	87F4836
11	Bus Adapter (9557)(with battery)	41G3877
	Battery	33F8354
12	System Boards (no memory)	
	486SLC2-25/50 MHz (9557)	39G6407
	486SLC3-33/66 MHz (9557)	65G8615
	486SX-33 MHz, for non-UltiMedia systems only (9577)	39G2668
	486SX-33 MHz (9577)	39G5698
	486DX2-33/66 MHz, for non-UltiMedia systems only (9577)	39G2669
	486DX2-33/66 MHz (9577)	39G6086
	Special Bid System Board (for Pinnacle CD-ROM Bootable Systems)	39G6444
	Optional Microprocessors	
	P23T 25/50 MHz	92F0147
	P23T 33/66 MHz	92F2582
	2MB Memory Module Kit (70ns)	92F0102
	4MB Memory Module Kit (70ns)	92F0105
	8MB Memory Module Kit (70ns)	64F3606
13	Control Assembly:	
	Assy - Without Volume Control (Power Switch, Cable, Speaker)	92F0002
	Assy - With Volume Control (Power Switch, with button, Cable, and Speaker)	41G3929
	Pedestal	92F0000
	Miscellaneous Parts Kit (see page 303)	92F0015

Index DASD (9557, 9577)

8	Drive Tray, 3.5-Inch Drive (Bays 1,2,3)	85F0097
	5.25-Inch Bay Drive Guides (2)	92F0014
9	1.44MB Diskette Drive	85F0050
	2.88MB Diskette Drive	64F4148
9	2.88MB 3.5-inch (with electronic eject)	92F0132
	3.5-inch Bezel (Bay 1, for 73G6059)	73G6067
	5.25-inch Bezel (Bay 1, for 73G6059)	73G6068
	5.25-inch Bezel (Bay 2, for 73G6059)	73G6069
	Bezel (Bay 1, for 92F0132)	92F0146
	Bezel (Bays 2 and 3, for 92F0132)	92F0133
	Diskette Drive Cable	96F7756
	1.2MB 5.25-Inch Diskette Drive	64F4102
	Rail Kit (for 64F4102)	85F0041
	(left/right rails, screws)	
7	40MB Hard Disk Drive (SCSI)	56F8866
7	60MB Hard Disk Drive (SCSI)	6128296
7	80MB Hard Disk Drive (SCSI)	56F8854
7	104MB Hard Disk Drive (SCSI)	95F4748
7	212MB Hard Disk Drive (SCSI)	95F4749
7	320MB Hard Disk Drive (SCSI)	85F0011
7	400MB Hard Disk Drive (SCSI)	85F0012
7	540MB Hard Disk Drive (SCSI)	92F0406
7	540MB Hard Disk Drive (SCSI)	61G3788
7	1GB Hard Disk Drive (SCSI) (9577)	92F0089
7	1GB Hard Disk Drive (SCSI)	92F0428
	Drive Cable (Three connector)	96F7649
	Drive Slide	96F7775
14	3.5-Inch Blank Bezel (Bay 4)	85F0092
	Bezel Insert (for 85F0092)	85F0095
15	5.25-Inch Louvered Bezel (Bay 3)	85F0094
	Bezel Insert (for 85F0094)	85F0096
	Air Baffle - Fixed Disk Drive Bay 4C	92F0251
16	3.5-Inch Diskette Drive Bezel (Bay 2,3)	85F0003
	5.25-Inch Diskette Drive Bezel (Bay 2,3)	64F4125
	5.25-Inch Blank Bezel (Bay 2)	85F0091
	CD-ROM Drive Bezel (Bay 2,3)	85F0008
	Rewritable Optical Drive Bezel	92F0159
17	3.5-Inch Diskette Drive Bezel (Bay 1)	85F0093
18	Retainer Plate	85F0098
19	Diskette Drive Cable	96F7756
20	Hard Disk Drive Cable	96F7649

Index Ultimedia (9557, 9577)

	CD ROM	92F0084
	ACPA Adapter	95F1256
	ActionMedia II Adapter	69F9733
	ActionMedia II to Display Cable	69F9737
21	Cable (Control Assy to Audio Card)	92F0113
22	Cable (Control Assy to System Board)	96F7762
	Cable (ACPA to ActionMedia II)	42G2779

Model 90 (8590) Parts

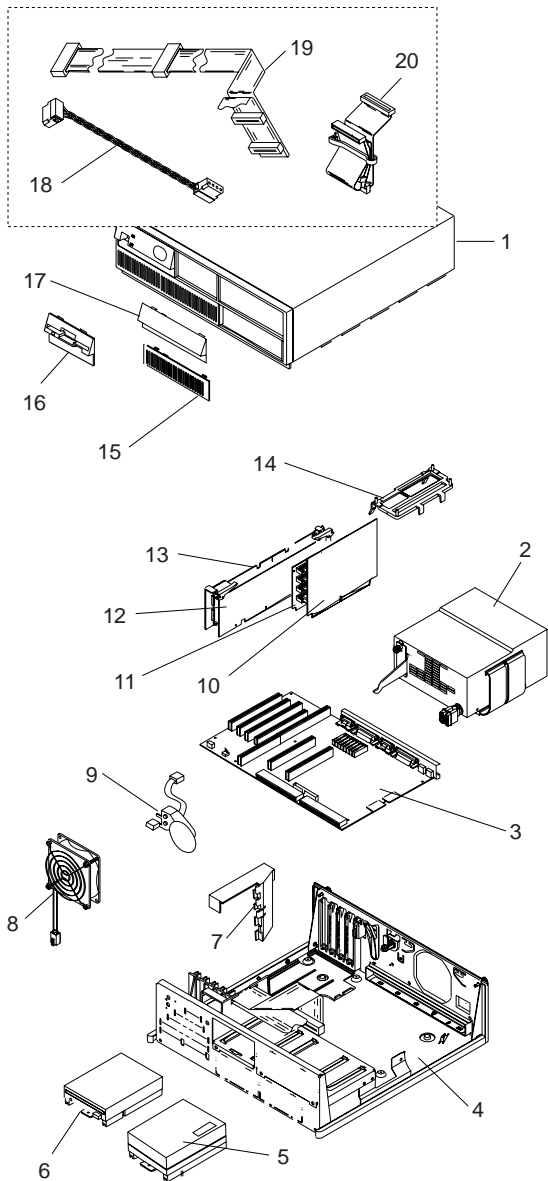

Index	System Unit (90)	
1	Top Cover	33F8350
	Logo	33F8367
2	Power Supply	92F0088
	Power Supply Bracket	64F4131
3	System Board (no memory)	64F3287
	System-Board Memory-Module Kits:	
	Parity Memory-Module Kits:	
	1MB (85ns) (Type 1 & 3 Boards only)	90X8624
	2MB (85ns) (Type 1 & 3 Boards only)	92F0104
	2MB (70ns)	92F0102
	2MB (80ns)	92F0103
	4MB High-Reliability Parity SIMM (70ns)	71G6203
	4MB (80ns)	92F3337
	8MB High-Reliability Parity SIMM (70ns)	71G6204
	8MB (80ns)	64F3607
	ECC Memory-Module Kits:	
	4MB (70ns) (Type 3 Boards only)	92F0097
	8MB (70ns) (Type 3 Boards only)	92F0098
4	Base Frame (R)	64F4116
	Keylock Assembly	33F8353
5	(see DASD)	
6	(see DASD)	
7	Air Baffle (for 57F1597)	92F0134
	Air Baffle (for all others)	64G4130
	Adapter Card-Guide Assembly	33F8363
8	Base Fan	64F4128
9	Power Switch/Speaker assembly	33F8352
10,11	Memory-Riser Card	81F8823
12	Processor Board (With cache option connector)	
	80486 (25 MHz)	64F0201
	80486 (33 MHz)	64F0198
	80486DX2 (33/66 MHz)	92F0145
	(runs internally at 66MHz)	
	256KB Cache 17ns	64F0199
	(for 64F0201, 64F0198, 92F0145)	
	80486 (50 MHz)	92F0048
	256KB Cache 12ns (for 92F0048)	92F0050
12	Processor Board (Without cache option connector)	
	80486SX 20 MHz	92F0049
	80487SX 20 MHz	92F0065
	80486SX 25 MHz	92F0079
	(With Dual Processor Sockets)	

Note:

See "20 and 25 Mhz Processor Boards" on page 284.

Index	System Unit (90)	
	80487SX Microprocessor (Extended Math Capability for 92F0079)	92F0100
	80486 25/50 MHz Overdrive Processor (runs internally at 50 MHz) (for 92F0079)	92F0147
	80486DX2 25/50 MHz (runs internally at 50 MHz)	92F0161
	80486 50 MHz (single socket, both boards are one single FRU)	57F1597
13	SCSI Adapter (with cache)	85F0063
13	SCSI Adapter (without cache)	85F0002
	Terminator, External (for 85F0063)	33F8464
	Terminator, Internal (for 85F0063)	34F0025
	Terminator, Internal (for 85F0002)	57F2870
	Terminator in-line (for 320/400MB)	92F0142
14	Memory-Riser-Card Support Bracket	57F3029
	Video-Memory Module	75X5894
	Battery	33F8354
	Label Kit	33F8367
	Miscellaneous Parts Kit (see page 301)	33F8370
	Shipping Carton	74F3583

Index DASD (90)

6	1.44MB 3.5-Inch Diskette Drive	64F0162
	Drive Slide (for 64F0162)	64F0156
6	2.88MB Drive (with slide)	64F0204
	(not supported on all early type 1 systems)	
	Drive Slide (for 64F0204)	64F0156
	5.25-Inch Diskette-Drive Bezel	33F8459
	5.25-Inch Hard Disk Drive Bezel	64F4104
15	Bezel for Hard Disk Drive	33F8361
16	3.5-Inch Diskette Drive Bezel	33F8360
	3.5-Inch Device Filler Bezel	64F4149
17	Blank Bezel for 5.25-inch Drive Bay	33F8362
18	Device Power Cable	33F8431
18	Device Power Cable	34F0014
	(supports two devices)	
19	SCSI Internal Cable	64F4127
20	Diskette Drive Signal Cable	57F3030
5	60MB Hard Disk Drive (SCSI)	6128296
5	80MB Hard Disk Drive (SCSI)	56F8854
5	104MB Hard Disk Drive (SCSI)	95F4748
5	120MB Hard Disk Drive (SCSI)	6128298
5	160MB Hard Disk Drive (SCSI)	56F8851
5	212MB Hard Disk Drive (SCSI)	95F4749
5	320MB Hard Disk Drive (SCSI)	85F0011
5	400MB Hard Disk Drive (SCSI)	85F0012
5	540MB Hard Disk Drive (SCSI)	92F0406
5	540MB Hard Disk Drive (SCSI)	61G3788
5	1GB Hard Disk Drive (SCSI)	92F0428
5	2GB Hard Disk Drive (SCSI) (8-bit 50-pin)	92F0440
5	2GB Hard Disk Drive (SCSI) (16-bit 68-pin)	92F0407
	EMC Bezel and Spring Shield	92F0407
	(for 92F0089)	
	Drive Slide (Model 90)	85F0035
	Drive Power Cable	33F8431
	Drive Power Cable (Two connector)	34F0014
	127MB Rewritable Optical Drive	92F0167
	Rewritable Optical Cartridge	38F8645
	Drive Mounting Slide (for 92F0167)	85F0022
	Tray with Bezel (for 92F0167)	85F0021
	CD-ROM I Drive Bezel	64F4122
	CD-ROM II Drive Bezel	92F0081
	Rewritable Optical Drive Bezel (B Bay)	92F0157
	Rewritable Optical Drive Bezel (D Bay)	92F0158
	Rewritable Optical Drive Bezel (Filler)	64F4149
	Large Ground Shield (Upper Bay)	85F0006
	Small Ground Shield (Upper Bay)	85F0005
	Ground Shield (Lower Bay)	85F0034

PC Server (8640) Parts

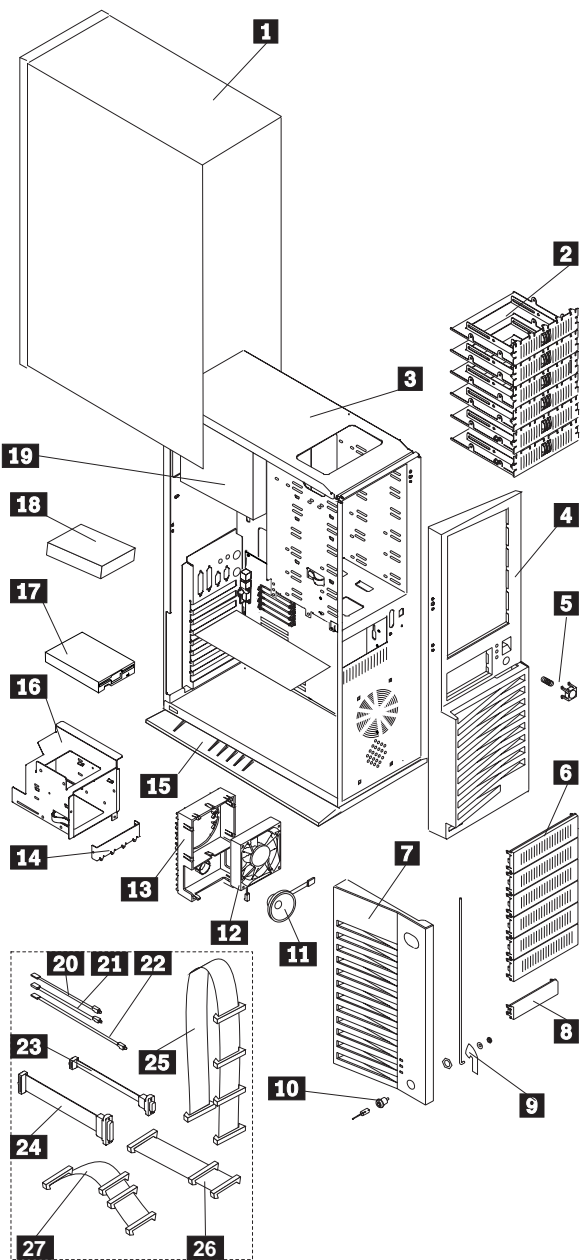

Index	System Unit (PC Server)	
1	Cover (Access/Rear Bezel)	71G0764
2	3.5" Hard Disk Drive Tray(s) (1 each)	06H2652
3	Base Frame Assembly	71G0032
4	Bezel (Front)	71G0765
5	Power Button (with spring)	06H2191
6	Bezel (5.25" Blank)	71G0771
7	Door (DASD with Lens)	71G0767
8	Bezel (3.5" Blank)	71G0770
9	Keylock Pawl and Rod	71G0769
10	Keylock Assembly (with keys)	33F8433
11	Speaker	06H2649
12	Fan Assembly (with Connector)	06H2647
13	Card Guide	71G0757
14	Shield (3.5" EMC)	71G0758
15	Pedestal	71G0763
16	Drive Cage (3.5")	71G0768
17	Diskette Drive (see DASD)	
18	Hard Disk Drive (see DASD)	
19	Power Supply (300W with Switch)	71G0044
	System Board, Pentium (without Memory and Processor)	71G0747
	Processor Chip (Pentium 60MHz)	06H2680
	System Board, 486 (without Memory and Processor)	71G0033
	Processor Chip (486DX2-66)	06H2679
	4MB Memory SIMM (Parity)	73G3233
	8MB Memory SIMM (Parity)	73G3234
	16MB Memory SIMM (Parity)	60G2950
	32MB Memory SIMM (Parity)	73G3235
	L2 Cache Memory	92G7431
	486 Real-Time Clock (with Battery)	06H3397
	Pentium Real-Time Clock (with Battery)	06H3398
	486 Heat Sink (with Clip)	06H2179
	Pentium Heat Sink (with Clip)	06H2180
	Keyboard (with Cable)	71G4646
	Power Cord	62X1045
	SCSI-2 Fast PCI-Bus Adapter	53G0382
	Spring (I/O EMC)	71G0756
	SVGA Card (AP and EMEA only)	71G0031
	VGA Card	71G0030
	Miscellaneous Parts Kit	06H2182
	EMC Gasket Keyboard/Mouse (1 each)	
	EMC Ground Contacts (4 each)	
	I/O Blank (1 each)	
	Nut Screws 4-40 (2 each)	
	Power Switch Bracket (1 each)	
	Screws 6X32X5/16" (6 each)	
	Screws 3x8mm Plastite (3 each)	
	Screws 3mm Diskette Drive (2 each)	
	Screws 6-32 Hard Disk Drive (2 each)	
	System Board Edge Support (1 each)	

Index Cables (PC Server)

20	Cable (Power Good, with Green LED)	06H2633
21	Cable (IDE Hard Disk Drive Activity, with Amber LED)	06H2637
22	Cable (SCSI Hard Disk Drive Activity, with Amber LED)	06H3379
23	Serial Cable	06H2165
24	Parallel Cable	06H2166
25	SCSI Cable Assembly (for 4 drives)	82G3626
	SCSI Cable Assembly (for 7 drives)	06H2181
26	IDE Hard Disk Drive Cable (for 2 Drives)	92F0424
27	Diskette Drive Signal Cable (with power)	92F0423

Index DASD (PC Server)

	Diskette Drives:	
17	1.44MB Diskette Drive Assembly	93F2361
17	1.2MB 5.25-Inch Diskette Drive Assembly	64F4102
	Hard Disk Drives:	
18	270MB Hard Disk Drive (IDE)	82G5926
18	364MB Hard Disk Drive (IDE)	82G5927
18	527MB Hard Disk Drive (IDE)	92F0405
18	728MB Hard Disk Drive (IDE)	82G5929
18	540MB Hard Disk Drive (SCSI)	92F0406
18	1GB Hard Disk Drive (SCSI)	92F0428
18	2GB Hard Disk Drive (SCSI)	92F0407
	Enhanced Internal CD-ROM II Drive	92F0084

PC Server 500 (Type 86XX) Parts

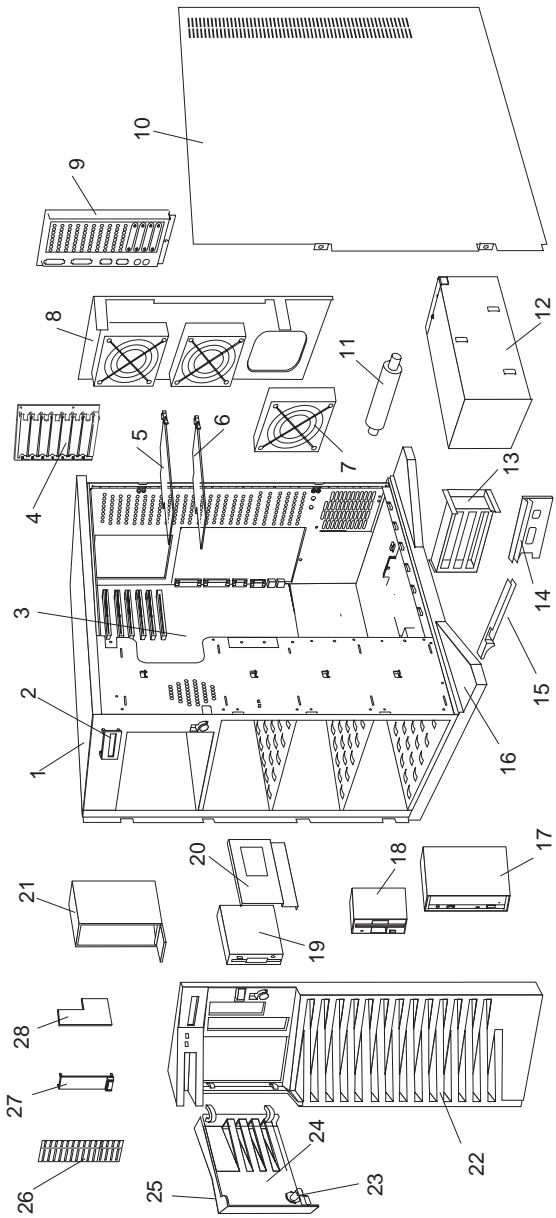

Index	System Unit (Type 86XX)	
1	Base Frame	82G3593
2	LED Information Display Assembly	06H3766
3	System Board	92F2623
	(without Memory and Processor)	
	I/O Spring (bracket on system board)	06H3796
	Pentium 90MHz Processor Card	06H3739
	16MB ECC Memory SIMM	96F9100
4	I/O Panel Die Cast	06H3593
5	SCSI RAID Hard Disk Drive Adapter	06H3059
5	SCSI Fast Wide Hard Disk Drive Adapter	92F0160
6	Video Adapter	71G0650
7	Fan Assembly	06H3407
8	Fan Mounting Support (without Fans)	82G3618
9	I/O Flex Plate	06H3594
10	Right Side Door	82G3594
	Right Side Door Hinges	82G3600
11	Pedestal Wheel (with Axle)	82G3609
12	434 Watt Power Supply	06H3596
13	Card Guide	82G3604
14	Processor Card Support	82G3959
15	Card Guide Support	82G3603
16	Pedestal	82G3608
17	Slim-Line CD ROM Drive	06H2150
18	2.88MB Diskette Drive	82G1888
19	1GB SCSI Hard Disk Drive	06H3371
19	2GB SCSI Hard Disk Drive	06H3372
20	DASD Hot Swap Tray Assembly (Wide)	06H3956
	DASD Hot Swap Backplane Assembly	71G6291
	DASD Hot Swap Cam Spring (Shaft and Knob)	06H5059
	DASD Mounting Plate	82G3602
21	CD Storage Tray	06H5060
22	Front Bezel (with Shield)	82G3595
23	Keylock (with Keys)	82G3606
24	DASD Door	82G3596
25	IBM Logo (R)	82G3601
26	5.25-Inch Drive Bezel (with Spacer)	82G3599
27	Control Panel Bezel	06H3595
28	Control Panel Card Assembly	06H3755
	Battery	33F8354
	Keyboard (with Cable)	71G4646
	Miscellaneous Parts Kit	82G3611
	C2 Spring (1 each)	
	EMI Ground Clips (4 each)	
	Hinge Screws 2 each)	
	Lock Pawl (1 each)	
	Planar Mounting Boss (2 each)	
	Screws (4 each)	
	Mouse	96F9258
	Power Cord	62X1045
	Speaker (with Bracket)	33F8444

Cables (Type 86XX)

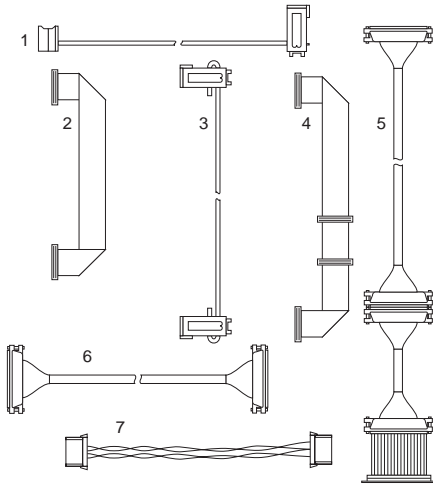

Index Cables (Type 86XX)

1	DASD Status Cable	06H5081
2	Planar/Control Panel Cable	06H3406
3	System Status Cable (1X4)	06H3404
4	Diskette Drive Signal Cable(with power)	06H3405
5	CD ROM SCSI Cable (for 2 drives)	06H3751
6	SCSI-Fast/Wide Cable (for 1 drive)	82G3613
7	Hard Disk Drive Power Cable (for 1 drive)	82G3610
	C2 Cable (with Switch)	82G3612
	LED Display Cable	06H6138
	POS ID Select Cable (Wide)	06H3957

Index Options (Type 86XX)

	DASD Hot Swap Tray Assembly (Narrow)	71G6292
	POS ID Select Cable (Narrow)	06H3592
	220 Watt Power Supply Assembly	06H3237

**Server 85 (9585), Model 95 XP 486
(8595) Parts**

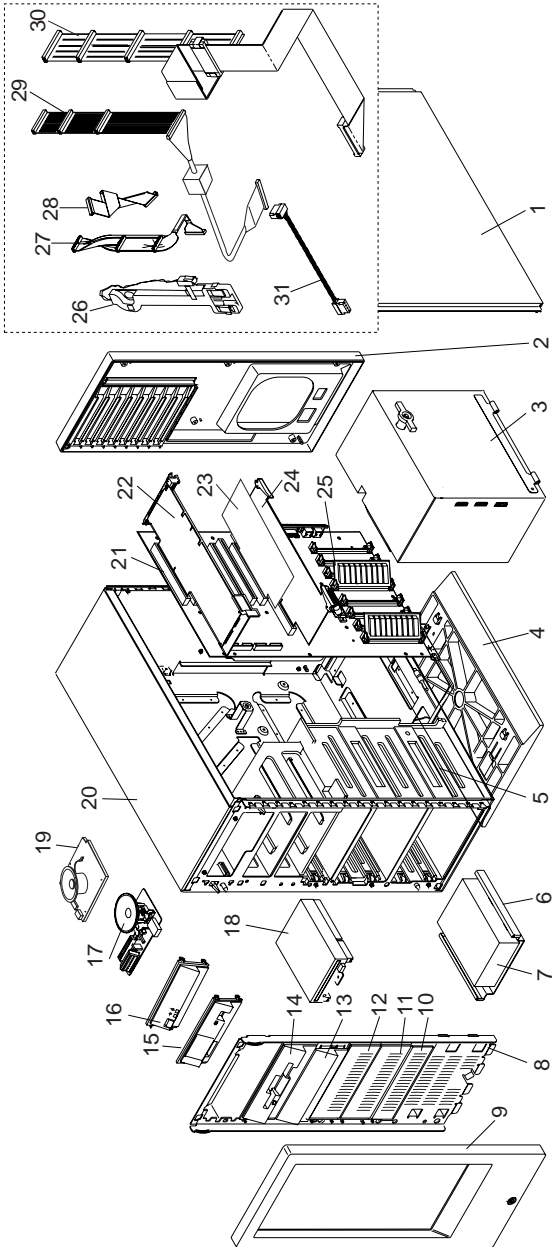

Index	System Unit (85, 95)	
1	Access Cover	33F8427
	Access Cover Fan	64F4115
2	Rear Bezel (85)	92F0279
2	Rear Bezel (95)	33F8419
3	288 Watt Power Supply (85)	92F2637
3	335 Watt Power Supply (95)	92F0051
	Power Supply Ground Strap	33F8418
4	Pedestal with Plate (85)	33F8422
4	Pedestal with Plate (95)	64F0215
5	Drive Support Structure (85)	92F0280
5	Drive Support Structure (95)	33F8421
	Ground spring (for 92F0280, 33F8421)	33F6853
6	(see DASD)	
7	(see DASD)	
	DASD Option Guide	33F8441
8	Drive Retainer	64F4135
9	Front Bezel	64F4137
15	Indicator Panel Bezel (85)	92F0281
16	Information Panel Bezel (95)	33F8423
17	Indicator Panel Assembly (85)	92F0277
18	(see DASD)	
19	Information Panel Assembly (95)	33F8434
	Information Panel kit (95)	33F8442
20	Base Frame (R) (85)	92F0278
20	Base Frame (R) (95)	33F8417
	Keylock Assembly	33F8433
	(also order Parts Kit)	33F8435
21	System Board Without Memory (85)	92F0270
	80486DX2-ODP 33/66-MHz	92F2582
	Microprocessor (85)	
21	System Board Without Memory (95)	33F5717
	Battery	33F8354
22	SCSI Adapter (with cache)	85F0063
22	SCSI Adapter (Without cache)	85F0002
	Terminator, External (for 85F0063)	33F8464
	Terminator, Internal (for 85F0063)	34F0025
	Terminator, Internal (for 85F0002)	57F2870
	Terminator in-line (for 320/400MB)	92F0142
23	Display Adapter (85)	
	(see Options and Adapters Matrix)	
	Adapter Guide (85)	33F8440
24	Processor Boards (95)	
	(With cache option connector):	
	80486 (25 MHz)	64F0201
	80486 (33 MHz)	64F0198
	80486DX2 (33/66 MHz)	92F0145
	(runs internally at 66MHz)	
	256KB Cache 17ns	64F0199
	(for 64F0201, 64F0198, 92F0145)	
	80486 (50 MHz)	92F0048
	256KB Cache 12ns (for 92F0048)	92F0050
24	Processor Boards	
	(Without cache option connector):	
	80486SX 20 MHz	92F0049
	80487SX 20 MHz	92F0065
	80486SX 25 MHz	92F0079

Index System Unit (85, 95)**Note:**

See "20 and 25 Mhz Processor Boards" on page 284.

	80487SX Microprocessor	92F0100
	(Extended Math Capability for 92F0079)	
	80486 25/50 MHz Overdrive Processor	92F0147
	(runs internally at 50 MHz)	
	(for 92F0079)	
	80486DX2 25/50 MHz	92F0161
	(runs internally at 50 MHz)	
	80486 50 MHz	57F1597
	(single socket, both boards	
	are one single FRU)	
	Adapter Guide	33F8440
25	System-Board Memory-Module Kits	
	Parity Memory-Module Kits:	
	1MB (85ns) (95)	90X8624
	(Type 1 & 3 Processor Boards)	
	2MB (85ns) (95)	92F0104
	(Type 1 & 3 Processor Boards)	
	2MB (70ns) (85, 95)	92F0102
	2MB (80ns) (95)	92F0103
	4MB High-Reliability Parity SIMM (70ns)	71G6203
	4MB (80ns) (95)	92F3337
	8MB High-Reliability Parity SIMM (70ns)	71G6204
	8MB (80ns) (95)	64F3607
	ECC Memory-Module Kits:	
	4MB (70ns) (Type 3 Boards only) (95)	92F0097
	8MB (70ns) (Type 3 Boards only) (95)	92F0098
26	Cover Fan Cable Assy	61G3824
28	Information Panel Cable (95)	33F8429
	Indicator Panel Cable (85)	92F0239
	Speaker	33F8444
	I/O Shadowbox Ground Spring	
	(with thumbscrews)	92F0099
	Miscellaneous Parts Kit (see page 301)	33F8435
	Shipping Carton	74F3565

Index DASD (85, 95)

6	Hard Disk Drive Mounting Tray (85)	85F0013
6	Hard Disk Drive Mounting Tray (95)	64F0141
7	60MB Hard Disk Drive (SCSI)	6128296
7	80MB Hard Disk Drive (SCSI)	56F8854
7	104MB Hard Disk Drive (SCSI)	95F4748
7	120MB Hard Disk Drive (SCSI)	6128298
7	160MB Hard Disk Drive (SCSI)	56F8851
7	212MB Hard Disk Drive (SCSI)	95F4749
7	320MB Hard Disk Drive (SCSI)	85F0011
7	400MB Hard Disk Drive (SCSI)	85F0012

Index DASD (85, 95) continued

7	540MB Hard Disk Drive (SCSI)	92F0406
7	540MB Hard Disk Drive (SCSI)	61G3788
7	1GB Hard Disk Drive (SCSI)	92F0089
7	1GB Hard Disk Drive (SCSI)	92F0428
7	2GB Hard Disk Drive (SCSI) (8-bit 50-pin)	92F0440
7	2GB Hard Disk Drive (SCSI) (16-bit 68-pin)	92F0407
	EMC Bezel and Spring Shield (for 92F0089)	92F0255
	Drive Power Cable	33F8431
	Drive Power Cable (Two connector)	34F0014
	127MB Rewritable Optical Drive	92F0167
	Drive Mounting Slide (for 92F0167)	85F0022
	Tray with Bezel (for 92F0167)	85F0021
	Objective Lens Cleaner (for 92F0167)	38F8681
	Prism Lens Cleaner (for 92F0167)	38F8682
10	DASD Bezel	64F4136
11	DASD Bezel	33F8425
12	DASD Bezel	33F8425
	2-Feature Bezel	64F0168
	5.25 Inch Diskette Drive Bezel	64F4103
	5.25 Framing Bezel	33F8459
	CD-ROM Drive I & II Bezel	64F0138
	Rewritable Optical Drive Bezel	92F0155
13	Diskette Drive Blank Bezel	71G5001
14	3.5-Inch Diskette Drive Bezel	71G5000
	3.5-Inch Device Filler Bezel	64F4149
18	1.44MB 3.5-Inch Diskette Drive	64F0162
	Drive Slide (for 64F0162)	64F0156
18	2.88MB Drive (with slide)	64F0204
	(not supported on all early type 1 systems)	
	Drive Slide (for 64F0204)	64F0156
	5.25-Inch Diskette Drive:	
	360KB External (4869-001)	72X6759
	360KB External (4869-501)	72X6768
	1.2MB External (4869-002)	15F7993
	1.2MB External (4869-502)	15F7994
	1.2MB Internal Drive (with rails)	64F4102
	1.2MB Rail kit (for 64F4102)	85F0041
	Slide kit (for 64F4102)	85F0040
23	Power Cable (95) (for 64F4115)	64F4120
27	Diskette Drive Signal Cable (85)	92F0283
27	Diskette Drive Signal Cable (95)	33F8430
29	SCSI Signal Cable (85)	92F0282
30	SCSI Signal Cable (95)	33F8436
31	Hard Disk Drive Power Cable	33F8431
31	Hard Disk Drive Power Cable (supports two devices)	34F0014

**Server 9595, PS/2 9585-xKx, and PS/2
9585-xNx Parts**

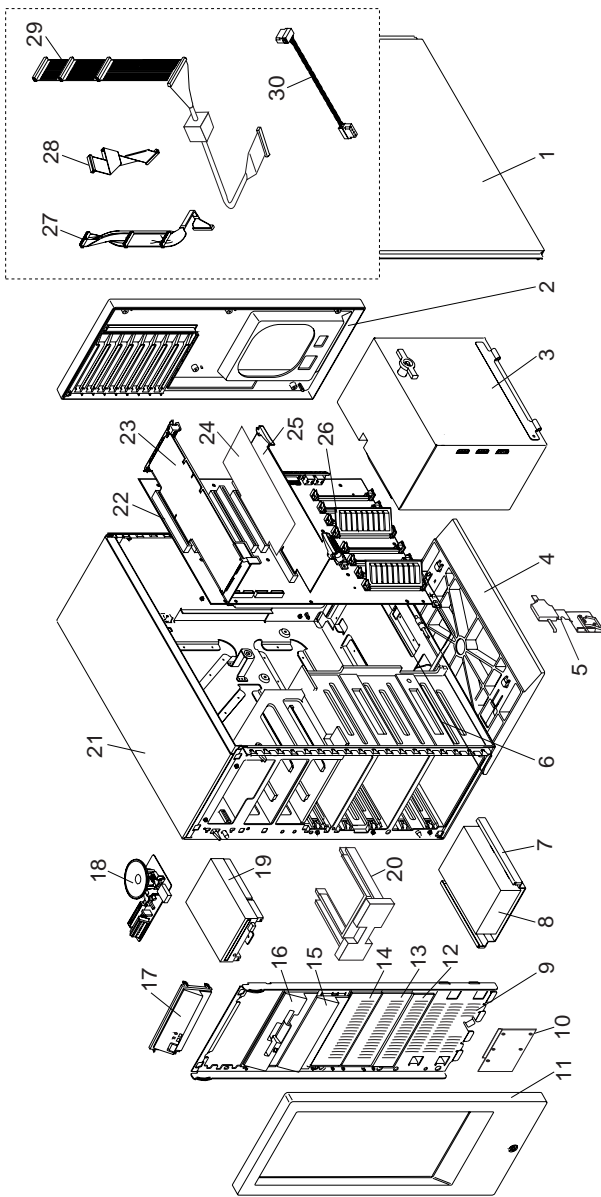

Index	System Unit (9595, 9585-xKx, 9585-xNx)	
1	Access Cover	61G3533
	Access Cover Fan	61G3827
	Access-Cover Fan Cable	61G3824
2	Rear Bezel	61G3823
	I/O Shadowbox Ground Spring (with thumbscrews)	92F0099
3	400 Watt Power Supply	92F0267
3	288 Watt Power Supply (for 9585-xKx, 9585-xNx)	92F2637
	Power Supply Ground Strap	33F8418
4	Pedestal (with plate)	33F8422
5	Tamper-Evident Switch/Cable Assembly	61G3518
6	Drive Support Structure	92F0280
	Ground Springs:	
	Left Spring	33F6853
	Right Spring	61G3528
7	(see DASD)	
8	(see DASD)	
9	Drive Retainer	61G3516
10	Tamper-Evident Linkage Assembly	61G3519
11	Front Bezel	61G3515
12	DASD Bezel (Small)	33F8425
13, 14	DASD Bezel (Medium)	64F4136
15	Blank Diskette Drive Bezel	33F8437
16	3.5-Inch Diskette Drive Bezel	33F8426
17	Operator Panel Bezel	92F0281
17	Operator Panel Bezel (for 9585-xKx, 9585-xNx)	61G3517
18	Operator Panel Card Assembly	92F0259
18	Operator Panel Card Assembly (for 9585-xKx, 9585-xNx)	61G3736
19	(see DASD)	
20	(see DASD)	
21	Base Frame (R)	61G3822
22	System Board (No Memory)	92F2623
22	System Board 486DX-33 w/SCSI (No Memory) (for 9585-xKx)	61G2405
22	System Board 486DX-33/66 w/SCSI (No Memory) (for 9585-xNx)	61G2401
	L2 Cache, 128KB (for 61G2405)	61G4098
	L2 Cache, 256KB (for 61G2401)	61G4099
23	SCSI-2 Adapter/A	92F0160
23	SCSI Adapter 16>8 (for 9585-xKx, 9585-xNx)	61G3594
24	ISO Display Adapter/A (for 9585-xKx, 9585-xNx)	39G3298
24	SVGA-NI Display Adapter/A	71G4877
24	MGA Ultima /2/M/H Video Graphics Adapter	06H2928
25	Processor Boards:	
	80486DX2 33/66 MHz	61G2343
	Pentium 60 MHz	52G9362
	Pentium 66 MHz	92F0120
	Pentium 90 MHz	06H3739
	Speaker	33F8444
	Keylock Assembly	61G3825
	Battery	33F8354
	Adapter Guide	33F8440

Index	System Unit (9595, 9585-xKx, 9585-xNx)	
26	System Board Memory Module Kits	
	Parity Memory Module Kits:	
	2MB (70ns)	92F0102
	4MB High-Reliability Parity SIMM (70ns)	71G6203
	8MB High-Reliability Parity SIMM (70ns)	71G6204
	ECC Memory-Module Kits:	
	4MB (70ns)	92F0097
	8MB (70ns)	92F0098
	16MB (70ns)	96F9100
27	(see DASD)	
28	Operator Panel Cable	92F0329
	(connects to system board)	
	Operator Panel Cable	61G3817
	(connects to processor card)	
	Cable Cover (Option)	61G3841
	Cable Cover Lock/Plug (Option)	61G3842
	Misc. Parts Kit	33F8435
	I/O Bracket (1)	
	Cable Clamp (1)	
	Jumper (1)	
	Lock Pawl (1)	
	Standoff (1)	
	Plastic Screws (2)	
	Metal Screws (6)	
Index	DASD	
	DASD Guide	33F8441
	DASD Ground Spring	96F9199
7	Drive Mounting Slide (for 92F0167)	85F0022
8	540MB 1/3 Ht. Hard Disk Drive	92F0406
8	1GB 1/3 Ht. Hard Disk Drive	92F0428
	Drive Power Cable (Two connector)	34F0014
	3.5-Inch 127MB Rewritable Optical Drive	92F0167
	2-Feature Bezel	64F0168
	5.25 Inch Diskette Drive Bezel	64F4103
	5.25 Framing Bezel	33F8459
	CD-ROM Drive I & II Bezel	64F0138
	Rewritable Optical Drive Bezel	85F0018
	3.5-Inch Device Filler Bezel	64F4149
19	1.44MB 3.5-Inch Diskette Drive	64F0162
	Drive Slide (for 64F0162)	64F0156
19	2.88MB Drive (with slide)	64F0204
20	Hard Disk Drive Mounting Tray	85F0013
27	Diskette Drive Signal Cable	92F0283
	Drive Slide (for 64F0204)	64F0156
29	SCSI Signal Cable	92F0327
30	Hard Disk Drive Power Cable	33F8431
	SCSI Internal Cable 8-Bit	61G3593
	(for 9585-xKx, 9585-xNx)	
	Multi-Drop Power Cable	64F0197

Server 9595A Parts

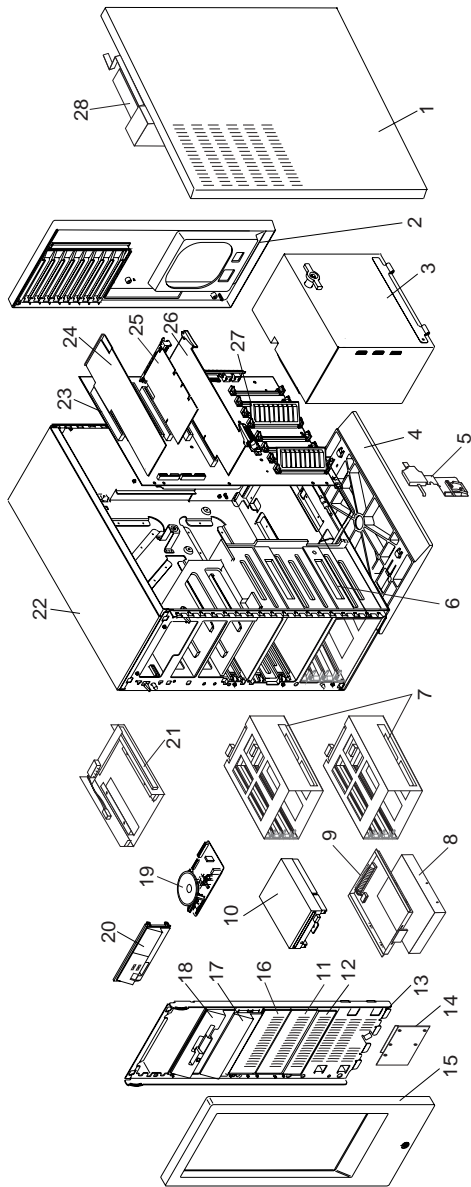

Index	System Unit (9595A)	
1	Access Cover	61G3533
2	Rear Bezel	61G3823
3	400 Watt Power Supply	92F0267
	Power Supply Ground Strap	33F8418
	Power Cord	62X1045
4	Pedestal (with plate)	33F8422
5	Tamper-Evident Switch/Cable Assembly	61G3518
6	Drive Support Structure	92F0280
7	Hot Plug Rack (3 bay)	61G3526
7	Hot Plug Rack (1 bay)	61G3527
	Microswitch Housing (for 61G3526, 61G3527)	61G3837
	Microswitch Assy (for 61G3526, 61G3527)	71G4981
	Microswitch Shaft (for 61G3526, 61G3527)	61G3838
8	see DASD	
9	Hot Plug Rack Rail	71G4982
	Hot Plug Adapter	61G3835
	Hot Plug Adapter Terminator	61G3836
10	2.88MB Diskette Drive (with slide)	64F0204
11, 16	DASD Bezel (medium)	64F4136
12	Feature Bezel (small)	33F8425
13	Drive Retainer	61G3516
14	Tamper-Evident Linkage Assembly	61G3519
15	Front Bezel	61G3515
17	Diskette Drive Blank Bezel	71G5001
18	3.5-Inch Diskette Drive Bezel	71G5000
19	Operator Panel Card Assembly	92F0259
	Speaker	33F8444
20	Operator Panel Bezel	61G3517
21	DASD Tray Assembly (without drive/cable)	61G3832
22	Base Frame (R)	61G3822
23	System Board (without Memory)	92F2623
	Battery	33F8354
24	SCSI Adapter for RAID Array Controller	92F0335
25	SVGA-NI Display Adapter/A	71G4877
26	Processor Boards	
	80486DX2-33/66 Processor	61G2343
	Pentium 60 MHz	52G9362
	Pentium 66 MHz	92F0120
27	System-Board Memory-Module Kits	
	Parity Memory-Module Kits:	
	2MB (70ns)	92F0102
	4MB High-Reliability Parity SIMM (70ns)	71G6203
	8MB High-Reliability Parity SIMM (70ns)	71G6204
	ECC Memory-Module Kits:	
	4MB (70ns)	92F0097
	8MB (70ns)	92F0098
	16MB (70ns)	96F9100
28	Access Cover Fan	61G3827
	Access-Cover Fan Cable	61G3824
	Keylock Assembly	61G3825
	Adapter Guide	33F8440

Index System Unit (9595A)

Ground Springs:

Left Spring	33F6853
Right Spring	61G3528
I/O Shadowbox Ground Spring (with thumbscrews)	92F0099
DASD Ground Spring	96F9199
Misc. Parts Kit	33F8435
I/O Bracket (1)	
Cable Clamp (1)	
Jumper (1)	
Retainer Gasket (1)	
Lock Pawl (1)	
Standoff (1)	
Plastic Screws (2)	
Metal Screws (6)	
Cable Cover (Option)	61G3841
Cable Cover Lock/Plug (Option)	61G3842

Index DASD

	2.88MB Diskette Drive (with slide)	64F0204
	Diskette Drive Cable (for 64F0204)	92F0283
	Diskette Drive Slide (1/3 Ht.)	64F0156
	540MB 1/3 Ht. Hard Disk Drive Assembly	92F0406
	Address Cable with tape (for 92F0406)	61G3833
	540MB 1/3 Ht. Hard Disk Drive Assembly (with tray/cable)	61G3525
8	1GB 1/3 Ht. Hard Disk Drive	92F0428
	Address Cable with tape (for 92F0428)	61G3834
	Blank Tray (for 92F0428)	61G3832
	1GB 1/3 Ht. Hard Disk Drive Assembly (with tray/cable)	61G3828
	3.5-Inch 127MB Rewritable Optical Drive	92F0167
	Drive Mounting Slide (for 92F0167)	85F0022
	2-Feature Bezel	64F0168
	5.25 Inch Diskette Drive Bezel	64F4103
	5.25 Framing Bezel	33F8459
	CD-ROM Drive I & II Bezel	64F0138
	Rewritable Optical Drive Bezel	85F0018
18	3.5-Inch Diskette Drive Bezel	33F8426

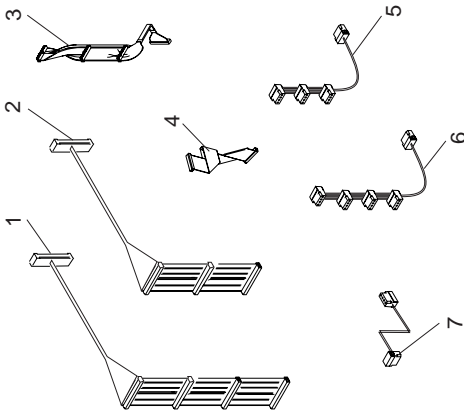

Index Cables (9595A)

1	SCSI Drive Cable Assembly (for 4 drives)	61G3524
2	SCSI Drive Cable Assembly (for 3 drives)	61G3523
3	Diskette Drive Signal Cable	92F0283
4	Operator Panel Cable (connects to system board)	92F0239
5	Hard Disk Drive Power Cable (for 3 drives)	61G3521
6	Hard Disk Drive Power Cable (for 4 drives)	61G3522
7	Operator Panel Cable (connects to processor card)	61G3817

20 and 25 Mhz Processor Boards: For SX models, you can install an optional processor on a 20 or 25 MHz processor board.

On the 20-MHz board (below left), the jumper 2 must be in positions 1 and 2 if a 487SX processor is installed in connector 3. If there *is not* a 487SX processor in connector 3, the jumper must be in positions 2 and 3.

The 25-MHz processor board (below right) has a *second* processor connector 3 for either an optional 487SX processor (extended math capability) or an 80486SX 25/50 MHz processor. If you install an option processor in connector 3, of the 25 MHz board, you *do not* have to remove the existing processor (it is overridden).

Carefully insert the tip of a screwdriver between the processor and the connector edge and *gently* twist the screwdriver (around all edges) until the processor raises up.

When you reinstall the processor, align the beveled corner 1 with the beveled corner marked on the board.

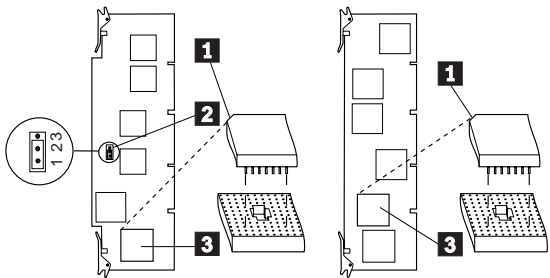

Model 3509 Parts

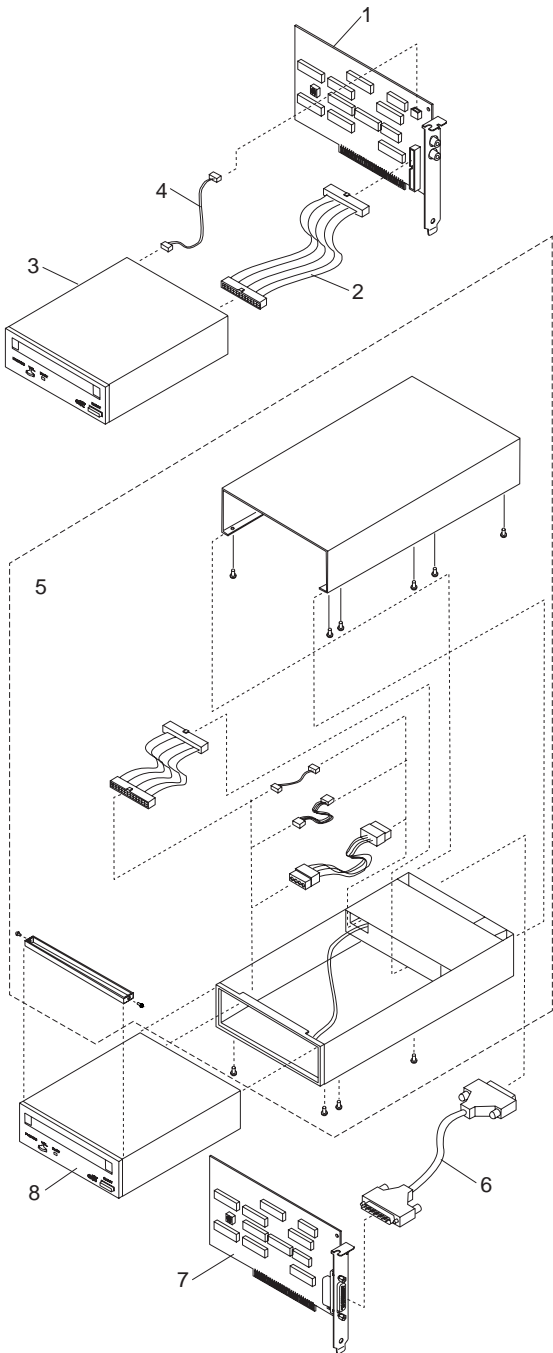

Index Internal ISA CD-ROM

1	Adapter	61G4110
2	Data Cable (40-wire ribbon cable)	61G4111
3	Drive	61G4109
4	Audio Cable	61G4112

Index External ISA CD-ROM

5	Drive Enclosure	61G4113
6	External Data Cable	61G4115
7	Adapter	61G4114
8	Drive	61G4109

Model 3510 Parts

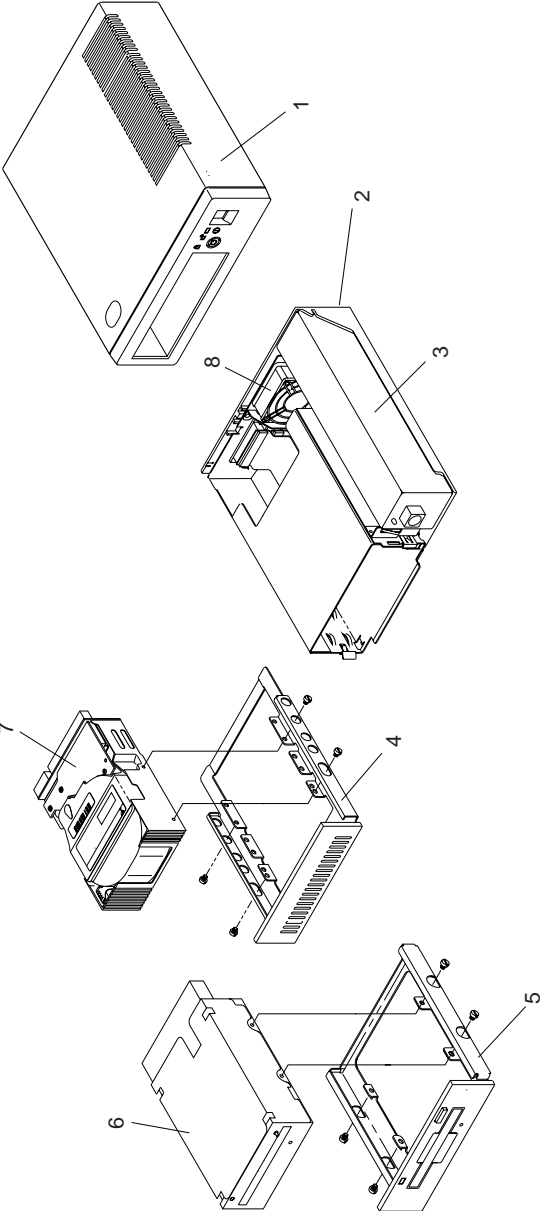

Index 3510 (Locking and Non-Locking Types)

1	External Cover (non-locking type) (Includes Base, Tray, Internal Cables, Phono Jack)	64F0135
1	Top Cover (R) (locking type) (Bezel, Logo, Keylock Assembly)	85F0027
	Keylock Assembly	33F8433
2	Base (R) (for 85F0027) (Label, Base Feet)	85F0072
3	Power Supply (for 85F0027)	85F0051
3	Power Supply (for 64F0135)	85F0051
4	Hard Disk Drive Tray with Bezel	64F4108
	Tray Shield Enclosure Kit	92F0007
	Hard Disk Drive Cable	92F0009
	SCSI Remote Address Switch and Cable	64F4107
	Remote ID Switch Cable	92F0086
	Audio Card, Cable, Screws	92F0085
5	Tray with Bezel (for 92F0167)	85F0021
	External CD-ROM (without rails)	81F7930
	Rail Kit (for 81F7930) Drive	34F0041
	CD-ROM Drive Assembly (WT)	34F0021
	Headphones (CD-ROM)	53F3610
	Cleaning Kit (CD-ROM) (Disc Kit, Test Disc, Disc Caddy)	59F3562
	Disc Caddy	22F9419
6	127MB Rewritable Optical Drive	92F0167
7	Hard Disk Drive	
	60MB Hard Disk Drive (SCSI)	6128296
	80MB Hard Disk Drive (SCSI)	56F8854
	104MB Hard Disk Drive (SCSI)	95F4748
	120MB Hard Disk Drive (SCSI)	6128298
	160MB Hard Disk Drive (SCSI)	56F8851
	212MB Hard Disk Drive (SCSI)	95F4749
	320MB Hard Disk Drive (SCSI)	85F0011
	400MB Hard Disk Drive (SCSI)	85F0012
	540MB Hard Disk Drive (SCSI)	92F0406
	1GB Hard Disk Drive (9577) (SCSI)	92F0089
	1GB Hard Disk Drive (SCSI)	92F0428
	2GB Hard Disk Drive (SCSI)	92F0440
	SCSI-2 Fast/Wide Adapter/A Upgrade Kit contains:	32G3920
	Back Cover Plate Assembly (with 16-Bit, 68 pin connectors and cable)	
8	Fan Assembly	92F0008
	Miscellaneous Parts Kit (see page 303)	92F0010
	System-to-Device Cable (60-to-50 pin)	34F0017
	Device-to-Device Cable (50-to-50 pin)	34F0018
	50-Pin Terminator	92F0057
	Power Cord	6952300

Model 3511 Parts

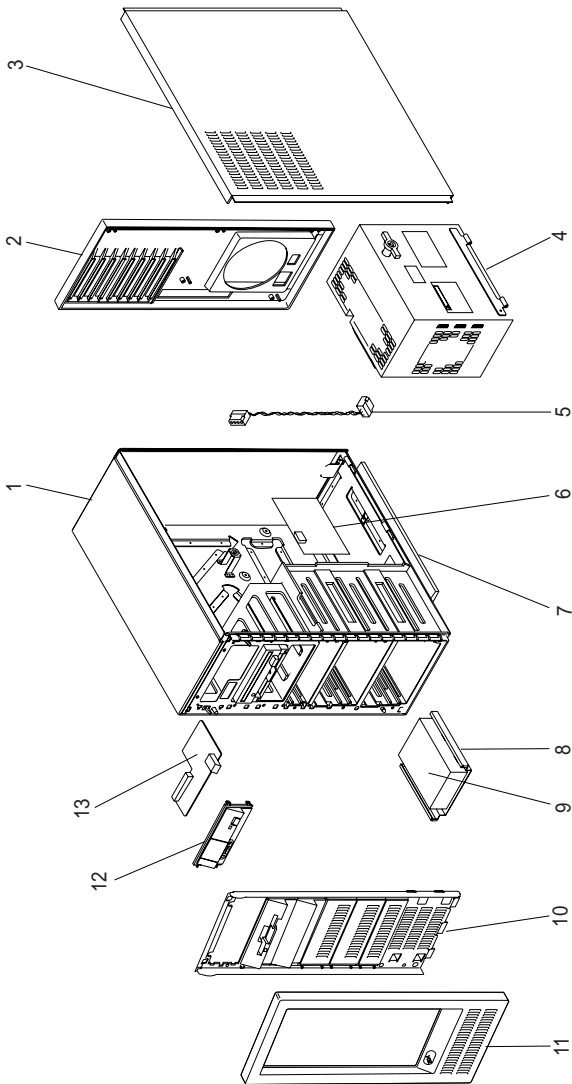

Index 3511 Storage Enclosure

1	Base Assembly	33F8417
2	Rear Bezel	33F8419
3	Cover Assembly	33F8427
	Rear Cover Plate	64F4121
4	335 Watt Power Supply	92F0051
4	400 Watt Power Supply	92F0267
5	Power Switch Cable	64F0125
6	Load Distribution Card	64F0139
7	Pedestal Assembly	64F0215
8	3.5 Inch Drive Tray	64F0141
9	60MB Hard Disk Drive (SCSI)	6128296
9	80MB Hard Disk Drive (SCSI)	56F8854
9	104MB Hard Disk Drive (SCSI)	95F4748
9	120MB Hard Disk Drive (SCSI)	6128298
9	160MB Hard Disk Drive (SCSI)	56F8851
9	212MB Hard Disk Drive (SCSI)	95F4749
9	320MB Hard Disk Drive (SCSI)	85F0011
9	400MB Hard Disk Drive (SCSI)	85F0012
9	540MB Hard Disk Drive (SCSI)	92F0406
9	1GB Hard Disk Drive (SCSI) (9577)	92F0089
9	1GB Hard Disk Drive (SCSI)	92F0428
9	2GB Hard Disk Drive (SCSI)	92F0440
	EMC Bezel/Spring Shield (for 92F0089)	92F0255
	Internal CD ROM (without rails)	81F7930
	Drive Bezel (for 81F7930)	64F0138
	Rewritable Optical Drive Bezel	92F0159
	SCSI Tape Drive (internal only)	85F0055
	SCSI Tape Drive (3532 only)	46G2320
	Framing Bezel (for 85F0055)	64F4138
	Rail Kit (for 85F0055)	34F0041
	Media Kit (Cleaning, Blank Tape)	59F3907
	Cleaning Tape	21F8593
	Blank Tape (Qty. 5)	21F8595
10	Drive Retainer	64F4135
11	Front Bezel	64F4137
12	Power Switch Bezel Assembly	64F0131
13	Power Switch / Speaker Assembly	64F0143
	Power Switch Kit (Plate, Knob)	33F8442
	Blank Bezel (for bays A and B)	33F8437
	Blank Bezel (for bay D-bottom)	64F4136
	Blank Bezel (for bays D-top and E)	33F8425
	Keylock Assembly	33F8433
	Option Device Guide	33F8441
	SCSI Cable	64F0127
	Device Power Cable (two devices)	34F0014
	Device Power Cable (three devices)	64F0197
	5.25-Inch Device Rail Kit	33F8443
	Rail Kit (for bays A and B)	64F0152
	Base Ground Strap	33F8418
	Base Ground Bracket	64F0129
	Miscellaneous Parts Kit (see page 301)	33F8435
	I/O Bracket Kit	64F0196
	System-to-Device Cable (50-to-60 pin)	34F0017
	Power Cord	6952300

Model 3532 Parts

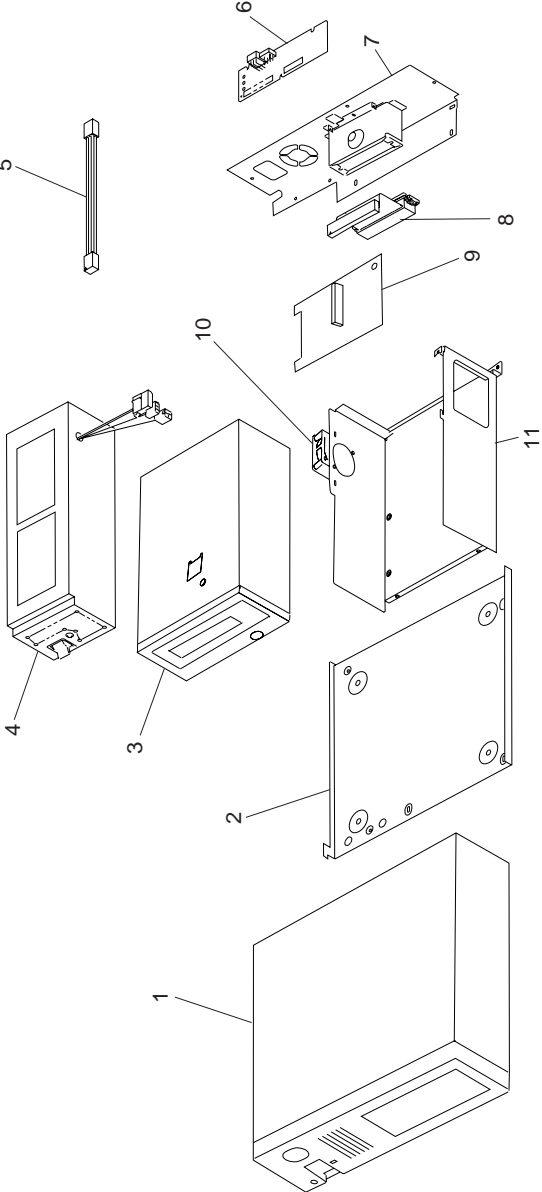

Index 3532 SCSI Tape Drive

1	Top Cover (R) (with Bezel, Logo)	00G0988
	Cover Screw	42F6707
	Cover Wrench	31F4220
2	Base (R)	42F6874
	Base Foot Pad	02G7413
3	SCSI Tape Drive (3532 only)	46G2320
	SCSI Tape Drive (internal only)	85F0055
	Drive Screw	0055726
4	Power Supply	00G2960
	Power Supply Screw	1621171
	Power Supply Cable Toroid	59F4585
5	Remote Address Switch Cable	42F7299
6	Remote Address Switch Board	53F3872
7	Rear Chassis (with Logo)	02G7398
	Rear Chassis Screw	42F6707
8	SCSI Cable	53F3861
	SCSI Cable Screw	0251970
9	Drive Tray Cover	42F7270
	Drive Tray Cover Screw	1621170
	Foam Spacer	71F0734
10	Drive Fan Assembly	42F7300
	Drive Fan Screw	0438553
11	Drive Tray	53F3113
	Base Flat Washer	1091414
	Base Star Washer	0060646
	Drive Tray Screw	1621171
	System-to-Device Cable	31F4221
	(60-to-50 pin, 3532 only)	
	Device-to-Device Cable	31F4222
	(50-to-50 pin, 3532 only)	
	Device-to-Device Cable (50-to-50 pin)	34F0018
	50-Pin Terminator	92F0057
	Power Cord	6952300
	Media Kit (Cleaning, Blank Tape)	59F3907
	Cleaning Tape	21F8593
	Blank Tape (Qty. 5)	21F8595

OBI DASD Hot Swap Storage Expansion Enclosure Parts

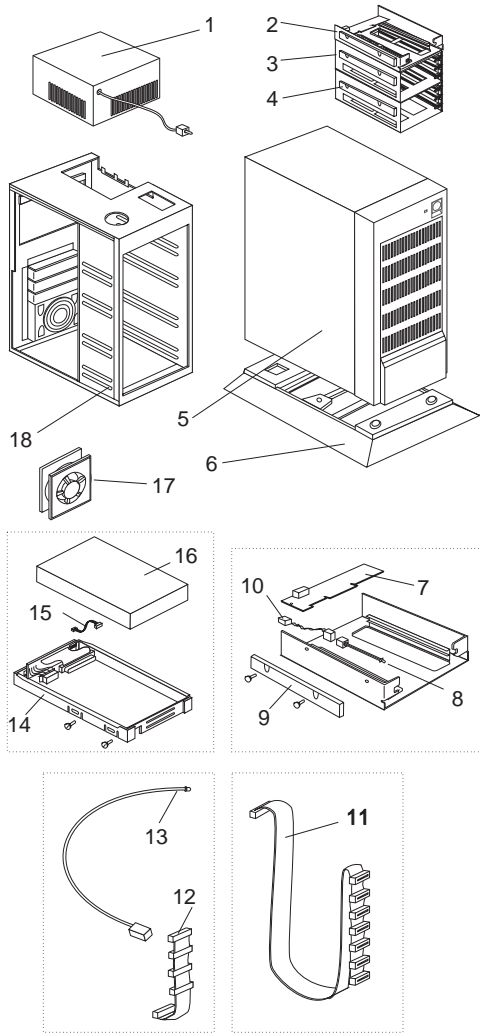

Index	Hot Swap Storage Expansion Enclosure	
1	200 Watt Power Supply	92F0411
2	Hot Swap Rack (1 bay)	61G3527
3	3-Tray Adapter (Top)	71G0208
4	3-Tray Adapter (Bottom)	71G0209
5	Cover Assembly	06H2605
	Keylock Assembly	61G2177
6	Pedestal	61G2174
7	Adapter Card Assembly, not Terminated	61G3835
	Adapter Card Assembly, Terminated (bottom card for 71G0209))	71G0216
8	Microswitch Shaft (for 71G0208, 71G0209, and 61G3527)	61G3838
	Microswitch Housing (for 71G0208, 71G0209)	61G3837
9	Hot Swap Rack Rail	71G4982
10	Microswitch Cable Assembly	71G4981
11	SCSI Cable Assembly	06H2601
12	Drive Power Cable Assembly	06H2602
13	Power-good Cable	06H3246
14	68 Position Tray Assembly	71G0212
15	1GB SCSI Fast/Wide Hard Disk Drive Tray Address Cable	71G0215
16	1GB SCSI Fast/Wide Hard Disk Drive	71G5040
17	Fan Assembly	71G0217
18	Base Frame Assembly	06H2604
	1-Meter External 68/68 Cable	06H3228
	Miscellaneous Parts Kit	06H3241
	Blank Bracket Screws (2)	
	EMC Springs (2)	
	Fan Mounting Screws (2)	
	Power Supply Mounting Screws (2)	
	Power Switch Mounting Screws (2)	
	Stand-off (2)	
	EMC Springs (2)	

Common Parts

486 DX, DX2, DLC2, SLC, SLC2 System Board Upgrade Parts

System Unit (50, 50Z)

486SLC2 System Board Upgrade	61G3502
486SLC2 Processor Upgrade Card (50)	71G2625
486SLC2 Processor Upgrade Card (50Z)	71G2633
2MB Memory Module	92F0102
4MB Memory Module	92F0105
4MB Memory Module (Industry Standard)	73G3233
8MB Memory Module	64F3606
16MB Memory Module	60G2950
80MB Hard Disk Drive	95F4721
170MB Hard Disk Drive	95F4728
245MB Hard Disk Drive	92F0403
340MB Hard Disk Drive	92F0404
527MB Hard Disk Drive	92F0405
Hard Disk Drive Ribbon Cable	71G2683
Hard Disk Drive Power Cable	71G2684

System Unit (55)

486SLC2 System Board Upgrade	71G2602
2MB Memory Module	92F0102
4MB Memory Module	92F0105
4MB Memory Module (Industry Standard)	73G3233
8MB Memory Module	64F3606
16MB Memory Module	60G2950
80MB Hard Disk Drive	95F4721
170MB Hard Disk Drive	95F4728
245MB Hard Disk Drive	92F0403
340MB Hard Disk Drive	92F0404
527MB Hard Disk Drive	92F0405
Hard Disk Drive Ribbon Cable	71G2662
Hard Disk Drive Power Cable	71G2684
Original Hard Disk Drive Cable	71G2685

System Unit (60, 65, and 80)

486DX2 System Board Upgrade	71G2643
486DLC2 System Board Upgrade	71G2610
486SLC2 Processor Upgrade Card (60)	71G2625
486DX33 Processor Upgrade Card (80)	92F0437

System Unit (70)

486DX33 Processor Upgrade Card	92F0436
486DX33 System Board Upgrade	71G2641
486DLC2 System Board Upgrade	71G2606

CD-ROM Drives

Internal CD-ROM I Drive (eject button above slot)	81F7930
Terminator Kit (for 81F7930)	59F3530
Cleaning Kit (for 81F7930) (Disks, CD Caddy)	59F3562
Internal CD-ROM II Drive	92F0084
(With eject button below slot)	
Enhanced Internal CD-ROM II Drive	61G1901
(With eject button below slot)	
Terminator Kit (for 92F0084)	92F0082
Signal Cable	34F0043
Power Cable	72X8521
Remote ID Switch Cable (3510)	92F0086
Audio Card, Cable, Screws (3510)	92F0085
Grounding Bracket (8560/8565/8580)	85F0010
Mounting Slide (8590)	92F0162
CD-ROM Drive Bezel Assemblies	
8557	85F0008
8560/8565/8580	34F0044
8590	92F0081
8595	64F0138
Media Kit (No Cleaning Necessary, for 92F0084)	31F4232
(Test Disk, CD Caddy)	
CD-ROM Parts:	
Ground Spring (Model 95)	92F0087
CD Caddy	22F9419
Rail Kit (8560/8565/8580/3510)	34F0041
Rail Kit (8557)	85F0009
Headphones	53F3610

Element Exchange Displays

8503 12-Inch Monochrome Display

110/120 V ac	68X3045
220/240 V ac (Northern Hemisphere)	68X3046
220/240 V ac (Southern Hemisphere)	72X7878
Tilt/Swivel Stand	68X3061

8504 12-Inch Monochrome Display

110/120 or 220/240 V ac (Universal Model)	44F9807
220/240 V ac (Northern Hemisphere)	44F9808
220/240 V ac (Southern Hemisphere)	44F9809
Tilt/Swivel Stand	44F9820

8506 17-Inch Monochrome Display (with Tilt/Swivel Stand)

110/125 V ac (US/Canada)	39F8087
110/125 or 200/240 V ac (Northern Hemisphere)	39F8088
110/125 or 220/240 V ac (Southern Hemisphere)	39F8089

8507 19-Inch Monochrome Display

110/120 or 220/240 V ac (Universal Model)	6247808
110/125 or 200/240 V ac (Northern Hemisphere)	6247843
110/125 or 220/240 V ac (Southern Hemisphere)	6247842

8508 19-Inch Monochrome Display

110/125 V ac (US/Canada)	6247883
110/125 or 200/240 V ac (Northern Hemisphere)	6247840
110/125 or 220/240 V ac (Southern Hemisphere)	39F8068

8512 14-Inch Color Display

110/120 V ac (US/Canada)	61X8924
220/240 V ac (Northern Hemisphere)	61X8928
220/240 V ac (Southern Hemisphere)	61X8927
Tilt/Swivel Stand	61X8925

8513 12-Inch Color Display

110/120 V ac	68X3088
220/240 V ac (Northern Hemisphere)	72X7870
220/240 V ac (Southern Hemisphere)	72X7877
Tilt/Swivel Stand	68X3061

8514 16-Inch Color Display

110/120 V ac	75X5945
220/240 V ac (Northern Hemisphere)	75X5946
220/240 V ac (Southern Hemisphere)	75X5947
Tilt/Swivel Stand	75X5907

8515 14-Inch Color Display

90/137 V ac	07G4759
220/240 V ac (Northern Hemisphere)	34G6628
220/240 V ac (Equatorial)	07G4762
220/240 V ac (Southern Hemisphere)	07G4763
Tilt/Swivel Stand	38F3909

8516 Color Touch Display

110/120 V ac	44F9759
220/240 V ac (Northern Hemisphere)	70F9129
220/240 V ac (Southern Hemisphere)	70F9132

External Diskette Drives

5.25-Inch Diskette Drive:	
360KB External (4869-001)	72X6759
360KB External (4869-501)	72X6768
1.2MB External (4869-002)	15X7993
1.2MB External (4869-502)	15X7994
5.25-Inch Drive Adapter	72X6757
5.25-Inch Drive Adapter/A	15F7996
5.25-Inch External Diskette Drive Cable (from system board to adapter)	27F4211

Keyboard/Mouse

Keyboard Cable	72X8537
Mouse	61X8923
Mouse Ball and Pop-Off Retainer	33F8461
Mouse Ball and Twist-Off Retainer	33F8462
Mouse (New Style)	33G5420
Mouse Retainer Ring	33G5417
Mouse (3-Button)	51G9652

Enhanced Keyboards (101/102 Key)

Arabic	1391490
Belgian	1391414
Canadian French	1392011
Cyrillic	1393866
Danish	1391407
Dutch	1391511
French	1391402
German	1391403
Greek	1393285
Hebrew	1391408
Italian	1393395
Latin American Spanish	1392015
Norwegian	1391409
Portuguese	1391410
Russian/Cyrillic	1395622
Spanish	1391405
Swedish/Finnish	1391411
Swiss	1391412
Swiss/French	1395881
Swiss/German	1395882
Turkish	1393286
U.K. English	1391406
U.S. English (E/ME/A use only)	1396790
U.S. English	1392090
Yugoslavian	1393669

Optional Enhanced Keyboards (101/102 Key)

with PS/2 Style Cable	59G7980
with AT Style Cable	59G7981
with 25mm PS/2 Trackball	59G7982
with 25mm Serial Trackball	59G9757

Keybutton Kits (101/102 Key)

Keybutton Kits (R), Belgian	1392033
Keybutton Kits (R), Canadian French	1392032
Keybutton Kits (R), Danish	1392026
Keybutton Kits (R), Dutch	1392034
Keybutton Kits (R), French	6447047
Keybutton Kits (R), German	6447048
Keybutton Kits (R), Italian	6447049
Keybutton Kits (R), Norwegian	1392028
Keybutton Kits (R), Portuguese	1392029
Keybutton Kits (R), Spanish	6447050
Keybutton Kits (R), Spanish/Latin	1392035
Keybutton Kits (R), Swedish	1392030
Keybutton Kits (R), Swiss/French/German	1392031
Keybutton Kits (R), U.K. English	6447046
Keybutton Kits, U.S. English	6447045

Japanese Keyboard Type 2 (106 Key, DBCS Support)

Japanese Keyboard	94X1110
Keyboard Cable	94X1147

Space-Saving Keyboards (84/85 Key)

Canadian French	1396046
Spanish/Latin	1396047
U.S. English	1393290
Cable Assembly, External	1393082

Host-Connected Keyboards (122 Key)

Austrian/German	1396902
Belgian	1396903
Canadian French	1397051
Cyrillic	1396916
Danish	1396904
Dutch	1396905
French	1396990
Greek	1396917
Icelandic	1396919
Italian	1396908
Latin American Spanish	1397052
Norwegian	1396909
Portuguese	1396910
Spanish	1396911
Swedish/Finnish	1396906
Swiss/French	1396912
Swiss/German	1396913
Turkish	1396921
U.K. English	1396914
U.S. English (E/ME/A use only)	1397025
U.S. English	1397050
Yugoslavian	1396920

Miscellaneous Parts Kits

Miscellaneous Parts Kit:	00F2113
3mm 5 x 5 screw w/washer (2)	
3mm 5 x 12 screw w/washer (2)	
3mm 5 x 8 screw (2)	
3mm 0 x 8 system board screw (8)	
3mm 0 x 8 CD support screw (2)	
4mm 0 x 6 drive mounting screw (2)	
5mm 0 x 10 tilt screw (2)	
Feature slot bracket (1)	
Feature card retainer (1)	
Red poly bag (1)	
Standoff w/washer (2)	
Top cover screw (2)	
Front foot pad (2)	
Front foot clip (2)	
Tilt leg spring (2)	
Miscellaneous Parts Kit:	07G1409
Front rubber foot (1)	
Rear rubber foot (1)	
Cover strap (1)	
Keyboard support (1)	
Track bracket (1)	
Safety cover (1)	
DC-DC cap (1)	
Miscellaneous Parts Kit:	07G1410
Rubber bumper (1)	
Screw and Spacer Kit:	07G1411
3mm L8 screw (2)	
4mm L4 screw (5)	
2.5mm L4 screw (5)	
2.5mm L12 screw (5)	
2.5mm L18 screw (5)	
2.5mm L5W screw (5)	
2.5mm L5B screw (5)	
2.5mm L5 screw (5)	
Plastic spacer (1)	
Plastic spacer B (1)	
Miscellaneous Parts Kit:	07G1743
Diskette drive A bracket (1)	
Diskette drive B bracket (1)	
LCD right support bracket (1)	
LCD left support bracket (1)	
Hard disk drive bracket (1)	

Screw Kit: 07G1835
2mm 5 x 4 black screw (10)
2mm 5 x 12 screw (10)
1mm 6 x 4 screw (10)
Tapping 2 x 4 screw (10)
2mm 5 x 8 black screw (10)
2mm 5 x 3 black screw (10)
Screw (10)
4-40 x 5 stud (20)
4-40 x 4.8 stud (10)
2mm 5 x 6 screw w/ washer (10)
2mm 5 x 5 screw (100)
Special screw (1)
2mm 0 x 5 (10)
3 x 4 screw (10)

Miscellaneous Parts Kit: 27F4171
Nut (2)
Cover screw (2)
I/O panel screw (2)
3.5mm captive screw (2)
Fingerstock shield (3)
Fingerstock base shield (3)
Slide (1)
Standoff shaft (2)
3mm screw (5)
Ground power special bracket (1)

Miscellaneous Parts Kit: 33F8370
Rubber foot (4)
8mm captive screw (4)
Captive screw (2)
3.5mm hex head screw (4)
3mm Plastite screw (4)

Miscellaneous Parts Kit: 33F8435
Screw (2)
Cable Cable clamp (1)
4mm screw (2)
Breakaway washer (1)
Pawl bracket (1)
Cable clamp (1)
Ground base spring (1)
I/O bracket (1)
PC board standoff (1)
Wing nut (1)
Ground spring (1)

Miscellaneous Parts Kit: Door bezel (1) Screw (2)	39G6574
Miscellaneous Parts Kit: Captive spring (4) Lock slide (2) Captive screw (4) Shaft standoff (2)	61X8915
Miscellaneous Parts Kit: 2MB memory holder (2) 1MB memory card shield (1) 2MB memory card shield (1)	72X7037
Miscellaneous Parts Kit: 4mm metric screw (4) Foot (2) Screw (1) Shaft standoff (2)	72X8525
Miscellaneous Parts Kit: Blank diskette drive bezel (1)	72X8535
Miscellaneous Parts Kit: I/O bracket (1) Diskette drive retainer (1)	72X8562
Miscellaneous Parts Kit: 4mm screw (2) Shaft standoff (2) Hard disk drive ground strap (1) Handle screw (2) Baffle cover nut (6)	72X8578
Miscellaneous Parts Kit: I/O bracket (1) 11.5 inch card holder (1) Flat cable clip (1)	72X8579
Miscellaneous Parts Kit: Captive fastener washer (1) Knob assembly (4) Captive cover screw (1) Retainer fastener (1)	72X8580

Miscellaneous Parts Kit:	79F3471
AT bracket (3)	
3.5mm hex head screw (9)	
Rubber foot (4)	
Christmas clip (1)	
Miscellaneous Parts Kit:	79F7209
Low cost screw (1)	
3.5mm hex head screw (6)	
MCA bracket (3)	
Rubber foot (4)	
Christmas clip (1)	
Miscellaneous Parts Kit:	92F0010
Rubber foot (4)	
Power knob (1)	
Breakaway washer (1)	
Pawl bracket (1)	
Pallet package ground (1)	
Miscellaneous Parts Kit:	92F0015
Thumbscrew (2)	
Retainer clip (2)	
Ground clip (3)	
Bracket (5)	
3.5mm steel screw (10)	
I/O bracket (5)	
Rubber foot (4)	
Finger ground (3)	
3mm screw (10)	
PS/2 Screw Kit:	92F0141
6/32 x 1/4 screws (4)	
Metric 3 x 5 screws (4)	
Metric 3 x 8 screws (4)	
Metric 3 x 10 screws (4)	
Metric 3 x 12 screws (4)	
Metric 3.5 x 6 screws (4)	
Metric 4 x 4 screws (4)	
Metric 4 x 8 screws (4)	
Metric 4 x 9 screws (4)	
Metric 4 x 10 screws (4)	
ID jumper (6)	
2 position jumper (6)	
Shunt with tab jumper (6)	

Power Cords

1	Display Power Cord, for: Colombia, U.S., Venezuela	6952300
1	System Unit Power Cord, for: Colombia, U.S., Venezuela	62X1045
2	System Unit Power Cord, for: Hong Kong, Singapore, U.K.	14F0033
3	System Unit Power Cord, for: France, Germany, Spain	13F9979
4	System Unit Power Cord, for: Italy, Chile	14F0069
5	System Unit Power Cord, for: Australia, New Zealand, New Guinea, Papua	13F9940
6	System Unit Power Cord, for: Denmark	13F9997
7	System Unit Power Cord, for: Israel	14F0087
8	System Unit Power Cord, for: Bangladesh, Pakistan, South Africa, Sri Lanka	14F0015
9	System Unit Power Cord, for: Switzerland	14F0051
10	System Unit Power Cord, for: Thailand	1838574
	System Unit Power Cord, for: Japan	79F2755

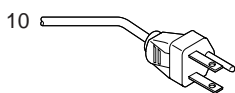
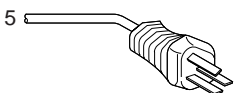
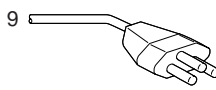
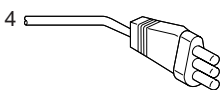
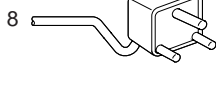
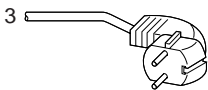
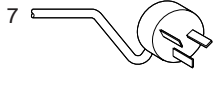
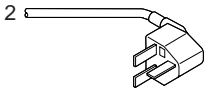
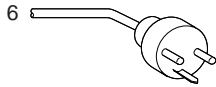
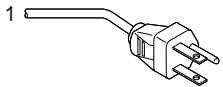

Rewritable Optical Drives

3.5-Inch Rewritable Optical Drive	92F0167
Rewritable Optical Cartridge	38F8647
Drive Mounting Slide (for 92F0167)	85F0022
Tray with Bezel (for 92F0167)	85F0021
Objective Lens Cleaner (for 92F0167)	38F8681
Prism Lens Cleaner (for 92F0167)	38F8682
3.5-Inch Enhanced Rewritable Optical Drive	92F0167
Mounting Tray	92F0269
Mounting Tray/Bezel (Model 3510)	92F0268
Drive Bezel Assembly:	
Model 8535, 8540, 8556, 8557, Bays 2, 3	92F0159
Model 9556, 9576	92F0159
Model 9557, 9577, Bays 2, 3	92F0159
Model 8560, 8565, 8580	92F0156
Model 8590, 9590 B-Bay	92F0157
Model 8590, 9590 D-Bay	92F0158
Model 8590, 9590 Filler	64F4149
Model 3511, 8595, 9595	92F0155

ServerGuard Adapter Parts

Adapter, ServerGuard	61G3628
Battery, Backup (3V Lithium)	33F8354
Battery Pack, Main (7.2V NiCad) for:	
Belgium	82G4776
Brazil	82G4776
Luxembourg	82G4776
Netherlands	82G4776
Taiwan	82G4776
All other countries	61G3629
Cable, External DAA-to-Modem (All countries except Japan)	92F0287
Cable, External DAA-to-PSTN for:	
Australia	58G4343
Austria	58G4386
Belgium	58G4346
Canada	43G3398
Chile	43G3398
China	58G4332
Czechoslovakia	43G3398
Denmark	58G4333
Finland	58G4334
France	58G4335
Germany	58G4347
Greece	43G3398
Hong Kong	58G4332
Hungary	43G3398
Iceland	58G4336
Ireland	43G3398
Israel	58G4338
Italy	58G4339
Japan	48G9594
Luxembourg	43G3398
Malaysia	43G3398
Netherlands	58G4340
Norway	58G4334
New Zealand	58G4332
Poland	43G3398
Portugal	43G3398
Romania	43G3398
Singapore	43G3398
South Africa	58G4344
Spain	43G3398
Sweden	58G4336
Switzerland	58G4348
Taiwan	43G3398
United Kingdom	58G4345
United States	43G3398
Yugoslavia	43G3398

DAA, External for:

Australia	43G3412
Austria	43G3399
Belgium	43G3414
Canada	43G3392
Chile	58G4330
China	54F0693
Czechoslovakia	54F0695
Denmark	43G4302
Finland	54F0715
France	43G3396
Germany	43G3415
Greece	54F0720
Hong Kong	54F0693
Hungary	54F0763
Iceland	43G4302
Ireland	43G3407
Israel	43G3392
Italy	43G3408
Japan (incl. DAA-to-Modem cable)	66G0902
Luxembourg	54F0996
Malaysia	58X9868
Netherlands	43G3409
Norway	43G3410
New Zealand	43G3411
Poland	54F0763
Portugal	54F0997
Singapore	43G3392
South Africa	54F0998
Spain	54F0999
Sweden	54F0717
Switzerland	43G3416
Taiwan	43G3397
United Kingdom	43G3413
United States	43G3392
Yugoslavia	54F0515

External Power Control Box 71G6222

Modem, PCMCIA Type II for:

Japan	66G0901
All other countries	92F0289

SCSI Adapter Terminators

Terminator, External (for 85F0063)	33F8464
Terminator, Internal (for 85F0063)	34F0025
Terminator, Internal (for 85F0002)	57F2870

Tools and Miscellaneous

Data Acquisition Distribution Panel	61X1769
Data Migration Facility	61X8936
Ethernet D-Shell Wrap Plug	85F0036
Ethernet BNC T-Connector	84F8207
Ethernet BNC 50-ohm Terminator (2 required)	85F0037
Grounding Wire Set	38F4684
Hard Disk Drive Removal Tool	64F4126
Keyboard Key Cap Removal Tool	6110464
Plastic Envelope (For Wrap Plug)	6138013
Processor Removal Tool (9577)	42G2565
Screwdriver Kit	95F3598
SCSI Terminator	92F0142
(any SCSI device, space permitting)	
SCSI Terminator Kit	92F0143
(R-PAC Terminator Modules (3) for 40, 60, 80, 120, and 160MB SCSI Hard Disk Drives)	
Snap Tool (for Snap Removal)	72X8547
Speech Control Assembly	61X1769
Video Memory Module Removal Tool	75X5893
Video Memory Module Insertion Tool	07F2518
Wrap Plug, ISDN Primary Rate Adapter	91F9161
Wrap Plug, Tri-Connector	72X8546
Wrap Plug (6157 Tape Attachment Adapter/A)	4178459
Wrap Plug (Token-Ring Network Adapter/A)	6165899
Wrap Plug (Realtime Interface Co-Processor Multiport/2) 78-pin	16F2478
Wrap Plug (for Multiport Interface Cable)	6425494
Direct Connect 25-pin, ports 0-1	
Wrap Plug (for Multiport Interface Cable)	09F1799
Direct Connect 25-pin, ports 2-7	

Wireless LAN Adapter (ISA, Micro Channel Bus)

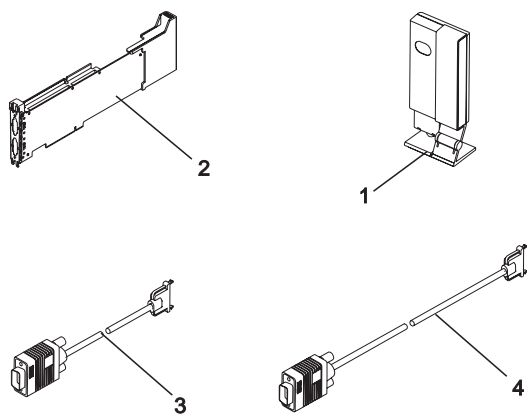

Index *Wireless LAN (ISA, Micro Channel Bus)*

1	Radio Module, Australia	80G2708
1	Radio Module, EMEA (Non-Europe)	80G2714
1	Radio Module, ETSI Countries	80G2702
1	Radio Module, Hong Kong	80G2707
1	Radio Module, Israel	80G2710
1	Radio Module, Japan	80G2703
1	Radio Module, Korea/New Zealand	80G2704
1	Radio Module, Mexico	80G2705
1	Radio Module, Singapore	80G2709
1	Radio Module, US/Canada/Non-EMEA	80G2701
2	IBM Wireless LAN Control Card	80G2700
2	IBM Wireless LAN Control Card, No-Cipher	80G2711
3	1.5 m cable	80G2713
4	4 m cable	54G2016

Wireless LAN Adapter (PCMCIA Type II)

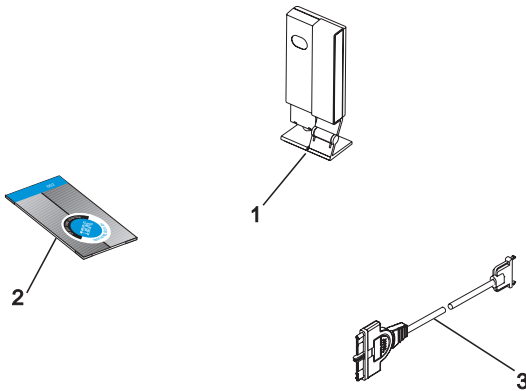

Index *Wireless LAN (PCMCIA Type II)*

1	Radio Module, Australia	80G2733
1	Radio Module, EMEA (Non-Europe)	80G2731
1	Radio Module, ETSI Countries	80G2727
1	Radio Module, Hong Kong	80G2732
1	Radio Module, Japan	80G2728
1	Radio Module, Korea/New Zealand	80G2729
1	Radio Module, Mexico	80G2730
1	Radio Module, Singapore	80G2734
1	Radio Module, US/Canada/Non-EMEA	80G2726
2	IBM Wireless LAN Controller Card,	80G2725
2	IBM Wireless LAN Controller Card, No-Cipher	80G2736
3	0.4 m Cable	80G2737

Options and Adapters Matrix

The following matrices provide listings of PS/2 computers and the options and adapters that they support. The options and adapters are listed according to function in the following order:

- Communication
- Communication (Networking Systems)
- Communication (Realtime Interface Options)
- Display/Audio Options
- Keyboard/Keypad/Mouse
- Memory
- Memory Options (for System Board Memory)
- Miscellaneous Options
- Multimedia
- Storage Device (Adapter)
- Storage Device (DASD)
- Processor Options
- System Board Memory (for Memory Options)

Locate the option or adapter in the left-hand column; then refer across the table for the information you need.

Communication	Feature Number	FRU Number	Option Number	Industry Standard Architecture (AT-Bus)	Micro Channel Architecture	PCMCIA	Warranty (Years)
1Mbps PCMCIA Infrared LAN Adapter (with Integrated Transceiver)	2525	-	87G9743	-	-	X	3
PCMCIA Adapter	-	87G9749	-	-	-	-	-
1Mbps ISA Infrared LAN Adapter (with external Transceiver)	2477	-	87G9741	X	-	-	3
ISA Adapter	-	87G9881	-	-	-	-	-
External Transceiver	-	87G8980	-	-	-	-	-
Transceiver Stand	-	0934962	-	-	-	-	-
1Mbps Micro Channel Infrared LAN Adapter (with external Transceiver)	2523	-	87G9742	-	X	-	3
Micro Channel Adapter	-	87G8982	-	-	-	-	-
External Transceiver	-	87G8980	-	-	-	-	-
Transceiver Stand	-	0934962	-	-	-	-	-
1Mbps PCMCIA Infrared LAN Adapter (with external Transceiver)	2476	-	87G9740	-	-	X	3
PCMCIA Adapter	-	87G9959	-	-	-	-	-
External Transceiver	-	87G8979	-	-	-	-	-
Transceiver Stand	-	0934321	-	-	-	-	-
4-Slot PCMCIA Adapter Assembly (for ISA)	0266	-	72G0485	X	-	-	5

Communication	Feature Number	FRU Number	Option Number	Industry Standard Architecture (AT-Bus)	Micro Channel Architecture	PCMCIA	Warranty (Years)
Bay Assembly	-	72G0483	-	-	-	-	-
Cable	-	72G0482	-	-	-	-	-
ISA Card	-	72G0484	-	-	-	-	-
14.4kbps/14.4kbps PCMCIA (with Integrated DAA)	1341	73G9343	73G7097	-	-	X	5
14.4kbps/14.4kbps External Data/FAX Modem (for ISA)	2294	92G8860	92G7446	X	-	-	5
14.4kbps/14.4kbps External Data/Fax Modem (Model 7851-001)	-	92G8861	92G7447	X	X	-	5
300/1200 Modem Adapter/A	-	34F0006	6450349	-	X	-	1
300/1200/2400 Modem Adapter/A	-	65X1253	94X1755	-	X	-	1
Communications Cable (for 65X1253)	-	94X1540	-	-	X	-	1
2400bps/9600bps PCMCIA Data/FAX Modem (with Integrated DAA)	1349	73G9321	73G7098	-	-	X	5
3270 Connection	-	74F3464	74F3465	-	X	-	1
3278/3279 Emulation Adapter	-	53F6424	53F6425	X	-	-	1
36/38 Emulation Adapter	-	69X6294	69X6279	-	X	-	1
Baseband Adapter	-	72X8102	1501223	-	X	-	1
Baseband Cable	-	72X8107	1501228	-	X	-	1

Communication	Feature Number	FRU Number	Option Number	Industry Standard Architecture (AT-Bus)	Micro Channel Architecture	PCMCIA	Warranty (Years)
Bisynchronous Communication Adapter	-	8286098	1501204	X	-	-	1
Broadband Adapter	-	72X8106	1501222	-	X	-	1
Communications Cable (for 34F0006)	-	8285985	-	-	X	-	1
Communications Cable (for 66X1253)	-	94X1540	-	-	X	-	1
Communications Adapter Cable	-	8529274	1502067	X	-	-	1
Dual Async Adapter/A	1014	34F0008	6451013 92G7515	-	X	-	1
DSP Modem	2296	92G5374	92G5365	X	-	-	5
Enhanced 5250 Emulation Adapter	-	82G7061	30F5383	X	-	-	1
Ethernet Adapter/A	-	92F0005	6451091	-	X	-	1
Ethernet Credit Card Adapter II, 10Base-T (with cable)	4331	0934331	0934331	-	-	X	5
10Base-T Cable (3m long)	-	92G9320	92G9320	-	-	-	-
Ethernet Credit Card Adapter II, 10Base2 (with cable)	4330	0934330	0934330	-	-	X	5
10Base2 Cable (8' long)	-	92G9319	92G9319	-	-	-	-
Ethernet ISA 10BASE2 Adapter (bayonet)	-	92F0387	-	X	-	-	1
Ethernet ISA 10BASE-T Adapter (twisted-pair)	-	92F0386	-	X	-	-	1
Ethernet Network Adapter (twisted-pair)	-	92F0045	-	X	-	-	1

Communication	Feature Number	FRU Number	Option Number	Industry Standard Architecture (AT-Bus)	Micro Channel Architecture	PCMCIA	Warranty (Years)
Ethernet Network Adapter (twisted-pair)	-	92F0046	6451136	-	X	-	1
FaxConcentrator Adapter/A	-	94X2540	94X2530	-	X	-	1
FaxConcentrator Adapter/A Cable	-	94X2527	-	-	X	-	1
FDDI Fiber Base Adapter/A	-	93F0345	-	-	X	-	1
FDDI Fiber Extender Adapter/A	-	93F0346	-	-	X	-	1
FDDI Copper Base Adapter/A	-	93F0347	-	-	X	-	1
FDDI Copper Extender Adapter/A	-	93F0348	-	-	X	-	1
High Speed Card Kit (for 3117 System)	-	65X1920	65X1925	-	X	-	1
High Speed Card Kit (for 3118 System)	-	65X1900	65X1905	-	X	-	1
IBM Credit Card Adapter For Ethernet, 10Base-T (with cable)	3290	0933290	0933290	-	-	X	5
10Base-T Cable (8' long MAM)	-	92G9319	92G9319	-	-	-	-
IBM Credit Card Adapter For Ethernet, 10Base2 (with cable)	3280	0933280	0933280	-	-	X	5
10Base2 Cable (8' long MAM)	-	0933264	0933264	-	-	-	-
IBM Wireless LAN - Advanced	8010	80G1000	80G1000	X	X	-	3
IBM Wireless LAN - Advanced	8090	80G0900	80G0900	-	-	X	3
ISA 14.4Kbps Data/Fax Modem with Wake-Up on Ring	4213	-	13H6686	X	-	-	5
14.4 Modem-Wake-Up	-	04H5788	-	-	-	-	-

Communication	Feature Number	FRU Number	Option Number	Industry Standard Architecture (AT-Bus)	Micro Channel Architecture	PCMCIA	Warranty (Years)
Wake-Up Cable	-	04H5934	-	-	-	-	-
ISA Multiprotocol Communications Adapter	2470	73G3223	73G7099	X	-	-	5
ISDN Interface Coprocessor/2 Model 2	-	44F7244	44F7728	X	-	-	1
ISDN Interface Coprocessor/2 Model 2	-	45F7230	44F7728	-	X	-	1
ISDN Cable Option (standard)	-	07F8946	-	-	X	-	1
ISDN Cable Option (Germany)	-	07F8947	-	-	X	-	1
ISDN Primary Rate Adapter	-	82G2656	-	-	X	-	1
LAN Streamer Adapter	-	92F8941	92F8942	-	X	-	1
Leased Line Modem	-	26F0724	26F1862	-	X	-	1
Modem Enabler	3593	-	92G7519	-	-	-	1
Modem Enabler Card	-	92G7586	-	-	-	-	-
115V AC Adapter	-	92G7587	-	-	-	-	-
Multiprotocol Adapter/A	-	85F0004	6451003	-	X	-	1
PCMCIA 14.4/14.4Kbps International Data/Fax Modem	4214	-	10H9355	-	-	X	5
PCMCIA Modem	-	10H8601	-	-	-	-	-
DAA - US/Canada	-	87G9408	-	-	-	-	-
DAA - UK	-	87G9382	-	-	-	-	-

Communication	Feature Number	FRU Number	Option Number	Industry Standard Architecture (AT-Bus)	Micro Channel Architecture	PCMCIA	Warranty (Years)
DAA - Germany	-	87G9384	-	-	-	-	-
DAA - Switzerland	-	87G9386	-	-	-	-	-
DAA - Finland	-	87G9388	-	-	-	-	-
DAA - Italy	-	87G9390	-	-	-	-	-
DAA - Netherlands	-	87G9392	-	-	-	-	-
DAA - Norway	-	87G9394	-	-	-	-	-
DAA - Denmark	-	87G9396	-	-	-	-	-
DAA - Sweden	-	87G9402	-	-	-	-	-
DAA - Australia	-	87G9404	-	-	-	-	-
DAA - Portugal	-	87G9388	-	-	-	-	-
DAA - New Zealand	-	87G9406	-	-	-	-	-
DAA - Belgium	-	10H9365	-	-	-	-	-
PCMCIA Multimedia Audio Adapter	3437	-	87G9748	-	-	X	1
PCMCIA Card Assembly	-	87G9549	-	-	-	-	-
Audio Interface Module	-	87G9550	-	-	-	-	-
PC Network Adapter	-	8286171	6450213	X	-	-	1
PC Network Adapter II	-	72X8105	1501220	X	-	-	1

Communication	Feature Number	FRU Number	Option Number	Industry Standard Architecture (AT-Bus)	Micro Channel Architecture	PCMCIA	Warranty (Years)
PC Network Adapter Cable	-	8286172	-	X	-	-	1
PC Network Baseband Adapter	-	72X8101	1501221	X	-	-	1
PhoneCommunicator Adapter	-	33F4846	6450619	X	-	-	1
PhoneCommunicator Cable (Black-L)	-	57F1261	-	X	-	-	1
PhoneCommunicator Cable (Black-S)	-	57F1262	-	X	-	-	1
PhoneCommunicator Cable (Beige-L)	-	57F1263	-	X	-	-	1
PhoneCommunicator Cable (Beige-S)	-	57F1264	-	X	-	-	1
PS/2 Multiprotocol Adapter/A	3043	85F0004	92G7516	-	X	-	1
PCMCIA RS232 Serial Adapter (with Cable)	2471	-	87G9250	-	-	X	5
PCMCIA RS232 Serial Adapter	-	87G9243	-	-	-	X	5
PCMCIA to 9-Pin Serial Cable	-	87G9244	-	-	-	X	-
PS/2 14.4Kbps/14.4Kbps Data/Fax Modem Adapter/A	2473	92G8867	92G7498	-	X	-	5
S/370 Channel Emulator	-	70X5061	6193413	X	-	-	1
S/370 Chan. Em. HMM & Disks (for 70X5061)	-	75X3256	-	X	-	-	1
S/370 Channel Emulator Adapter/A	-	06F3160	1674899	-	X	-	1
S/370 Chan. Em. Cable (for 06F3160, 70X5061)	-	70X4865	-	-	X	-	1
S/370 MCA to Mainframe Connection	-	12G8067	-	-	X	-	1

Communication	Feature Number	FRU Number	Option Number	Industry Standard Architecture (AT-Bus)	Micro Channel Architecture	PCMCIA	Warranty (Years)
SDLC Adapter	-	8286099	1501205	X	-	-	1
Serial Infrared, for ISA	4839	08H3736	08H3654	X	-	-	3
Infrared Transceiver	-	08H3739	-	-	-	-	-
Serial Infrared, for Micro Channel	4856	08H3737	08H3655	-	X	-	3
Infrared Transceiver	-	08H3739	-	-	-	-	-
Serial Infrared, for PCMCIA	4838	08H3738	08H3656	-	-	X	3
Infrared Transceiver	-	08H3740	-	-	-	-	-
Store Loop Adapter	-	34G1185	83X8187	-	X	-	1
Token-Ring 16/4 Adapter/A	-	93F0331	74F9410	-	X	-	1
Token-Ring 16/4 Adapter/A RPL Module	-	74F9415	25F8887	-	X	-	1
Token-Ring 16/4 Bus Master Adapter/A	-	74F4149	74F4140	-	X	-	1
Token-Ring 16/4 Adapter	-	93F0334	25F7367	X	-	-	1
Token-Ring RPL Module (for 93F0334)	-	25F8887	-	X	-	-	1
Token-Ring Adapter	-	16F0463	25F9858	X	-	-	1
Token-Ring Adapter (with RPL Module)	-	83X7839	-	X	-	-	1
Token-Ring Adapter/A	-	25F7540	69X8138	-	X	-	1
Two Slot Front Access PCMCIA Adapter for ISA	4836	-	81G4246	X	-	-	5

Communication	Feature Number	FRU Number	Option Number	Industry Standard Architecture (AT-Bus)	Micro Channel Architecture	PCMCIA	Warranty (Years)
ISA Card-2 Slot	-	81G4632	-	-	-	-	-
Drive Bay Assembly	-	81G4633	-	-	-	-	-
Cable Kit	-	81G4635	-	-	-	-	-
Two Slot Front Access PCMCIA Adapter for Micro Channel	4837	-	81G4256	-	X	-	5
MCA Card-2 Slot	-	81G4261	-	-	-	-	-
Drive Bay Assembly	-	81G4633	-	-	-	-	-
Cable Kit	-	81G4635	-	-	-	-	-
RPL Module (for 25F7540)	83X9180	-	25F8887	-	X	-	1
Token-Ring RPL Module (for 93F0334)	-	25F8887	-	X	-	-	1
V.32BIS DSP Data/Fax Modem	2296	92G7502	92G7501	X	-	-	5

Communication (Networking Systems)	Feature Number	FRU Number	Option Number	Industry Standard Architecture (AT-Bus)	Micro Channel Architecture	PCMCIA	Warranty (Years)
3270 PCMCIA Adapter	2812	0933315	0933315	-	-	X	5
Ethernet 10BASET Adapter	0605	92F0386	60G0605	X	-	-	5
Ethernet 10BASE2 Adapter	0615	92F0387	60G0615	-	X	-	5
Ethernet CX II PCMCIA Adapter	4330	0933280	0934330	-	-	X	5
Ethernet TrackPoint II PCMCIA Adapter	4331	0933290	0934331	-	-	X	5
ISA Waverunner Adapter	7478	73G1393	73G1393	X	-	-	1
Token Ring II PCMCIA Adapter	8072	0933462	0933462	-	-	X	5
Token Ring EISA 16/4 Busmaster Adapter	0412	63F0412	63F0412	-	X	-	1
Token Ring ISA-16 Adapter	7462	78G9645	73G2032	X	-	-	5
Token Ring MAU Adapter	-	6091014	6091014	-	X	-	1
Token Ring Micro Channel Adapter	0149	74F9410	74F9410	-	X	-	1

Communication (Realtime Interface Options)	Feature Number	FRU Number	Option Number	Industry Standard Architecture (AT-Bus)	Micro Channel Architecture	PCMCIA	Warranty (Years)
1-Port X.21 Cable (Port 0 Only, Selectable)	-	57F2751	-	-	X	-	1
1-Port V.35 Cable (Port 0 Only, Selectable)	-	57F2752	-	-	X	-	1
4, 8 and 4/4 Elec Interface Brd Wrap Plug	-	16F2478	-	-	X	-	1
4 Port RS-232-C / 4 Port RS-422-A Elec Interface Brd	-	91F7966	-	-	X	-	1
4 Port RS-232-C Elec Interface Brd	-	91F7976	09F1955	-	X	-	1
4-port RS232-C Elec Interface Brd	-	09F1957	-	-	X	-	1
6 Port Sync RS-232-C Elec Interface Brd	-	91F7963	-	-	X	-	1
6 Port Sync Elec Interface Brd Wrap Plug	-	15F8859	-	-	X	-	1
6-Port X.21 Cable (World Trade)	-	04G5501	-	-	X	-	1
6-Port X.21 Cable Wrap Plug Port 0-5 (World Trade)	-	85F0206	-	-	X	-	1
6-Port X.21 Interface Brd/A (World Trade)	-	04G5500	-	-	X	-	1
6-Port V.35 Cable	-	72F1966	-	-	X	-	1
6-Port V.35 Cable Wrap Plug Port 0-5	-	72F0167	-	-	X	-	1
6-Port V.35 IB Wrap Plug	-	72F0168	-	-	X	-	1
6-Port V.35 Interface Brd/A	-	72F0164	-	-	X	-	1
8-Port Interface Cable	-	53F2621	-	X	X	-	1
8 Port RS-232-C Elec Interface Brd	-	91F7974	53F2610	-	X	-	1

Communication (Realtime Interface Options)	Feature Number	FRU Number	Option Number	Industry Standard Architecture (AT-Bus)	Micro Channel Architecture	PCMCIA	Warranty (Years)
8-Port RS-232-D Interface Brd (IB)	-	53F2612	-	X	X	-	1
8-Port RS-232 Interface Brd/A Wrap Plug	-	15F8848	-	X	X	-	1
8 Port RS-422-A Elec Interface Brd	-	15F8858	-	-	X	-	1
8-Port RS-422-A Interface Brd (IB)	-	53F2615	-	X	X	-	1
8-Port RS-422 Interface Brd/A Wrap Plug	-	57F0678	-	X	X	-	1
15-Pin Wrap Plug (V.35 Port 0 & 1, Selectable)	-	40F9900	-	-	X	-	1
15-Pin Wrap Plug (X.21 Port 0, Selectable)	-	40F9904	-	-	X	-	1
20-MA Current Loop Elec Interface Brd	-	58X7288	-	X	-	-	1
25-Pin Wrap Plug (RS-232-C Port 0 - 3, Selectable)	-	40F9903	-	-	X	-	1
25-Pin Wrap Plug (RS-422-A Port 0 & 2, Selectable)	-	53F3886	-	-	X	-	1
34-Pin Wrap Plug (V.35 Port 0 Only, Selectable)	-	71F0163	-	-	X	-	1
78-Pin Wrap Plug for Selectable IB	-	40F9902	-	-	X	-	1
78-Pin Wrap Plug for X.21 IB (World Trade)	-	85F0205	-	-	X	-	1
64KB X 1 Memory Module (for 16F2223)	-	60X8200	-	X	-	-	1
128KB Realtime Interface Coprocessor	-	60X8192	85X2710	X	-	-	1
128KB Realtime Interface Coproc Multiport	-	16F2223	00F5527	X	-	-	1
256KB X 1 Memory Module (for 16F2223)	-	76X1022	-	X	-	-	1

Communication (Realtime Interface Options)	Feature Number	FRU Number	Option Number	Industry Standard Architecture (AT-Bus)	Micro Channel Architecture	PCMCIA	Warranty (Years)
256KB Memory Module, for 04G5827	-	10G6927	-	-	X	-	1
256KB Memory Module, for 44F7123	-	16F2267	-	-	X	-	1
512KB Realtime Interface Coprocessor	-	76X1013	85X2706	X	-	-	1
512KB Memory Module (2 for p/n 09F1888)	-	16F2267	-	-	X	-	1
512KB Realtime Interface Coproc Multiport/2	-	09F1888	16F2267	-	X	-	1
1MB Memory Module (2 for p/n 09F1962)	-	16F2265	-	-	X	-	1
1MB Realtime Interface Coproc Multiport/2	-	09F1962	-	-	X	-	1
Dir Conn 25-Pin Wrap Plug (RS-232-D Ops, Port 0-7)	-	33F8985	-	-	X	-	1
Dir Conn 25-Pin Wrap Plug (RS-422-A Ops, Port 0-7)	-	33F8964	-	-	X	-	1
Dir Conn 25-Pin Wrap Plug for Port 2-7	-	09F1799	-	-	X	-	1
High-Speed Comm Card	-	04G5827	04G5835	-	X	-	1
Memory Module (64KB X 1), for 76X1013	-	60X8200	-	X	-	-	1
Memory Module (256KB X 1), for 76X1013	-	76X1022	-	X	-	-	1
Multiport Interface Cable	-	00F5524	00F5331	X	X	-	1
Parts Kit (Screws, Jumpers, etc.)	-	67X1609	-	X	-	-	1
Realtime Interface Coproc Multiport Adapter Module	-	33F8967	33F8971	X	-	-	1
Realtime Interface Coproc Portmaster Adapter/A	-	53F2603	53F2660	-	X	-	1

Communication (Realtime Interface Options)	Feature Number	FRU Number	Option Number	Industry Standard Architecture (AT-Bus)	Micro Channel Architecture	PCMCIA	Warranty (Years)
Realtime Interface Coproc Wrap Plug	-	16F2478	-	X	-	-	1
Realtime Interface Coproc Wrap Plug	-	64Z5492	-	X	-	-	1
RS-232-C Elec Interface Brd	-	58X7285	-	X	-	-	1
RS-232-C Dir Connect Wrap Plug	-	64Z5493	-	X	-	-	1
RS-232-C Dir Connect Cable	-	67X1245	-	X	-	-	1
RS-232-C Dir Conn Wrap Plug (Port 0 & 1)	-	64Z5494	-	X	X	-	1
RS-232-C Dir Conn Wrap Plug (Port 0 - 3, Selectable)	-	40F9003	-	X	-	-	1
RS-232-C Dir Conn Wrap Plug (Port 0 - 7)	-	09F1799	-	X	-	-	1
RS-232-C Modem Attach Cable	-	67X1247	-	X	-	-	1
RS-232-C Modem Attach Wrap Plug	-	64Z5494	-	X	-	-	1
RS-232-C Multiport Elec Interface Brd	-	09F1796	-	X	-	-	1
RS-232-D OPs, Dir Conn 25-Pin Wrap Plug (Port 0-7)	-	57F0888	-	X	-	-	1
RS-422-A 25-Pin Wrap Plug (Port 0 & 2, Selectable)	-	53F3886	-	X	-	-	1
RS-422-A Elec Interface Brd	-	58X7286	-	X	-	-	1
RS-422-A Multiport Elec Interface Brd	-	09F1937	-	X	-	-	1
RS-422-A OPs, Dir Conn 25-Pin Wrap Plug (Port 0-7)	-	57F0089	-	X	-	-	1
Selectable Cable	-	53F2624	-	X	X	-	1

Communication (Realtime Interface Options)	Feature Number	FRU Number	Option Number	Industry Standard Architecture (AT-Bus)	Micro Channel Architecture	PCMCIA	Warranty (Years)
Selectable Interface Brd	-	84F7540	-	X	X	-	1
Selectable IB 78-Pin Wrap Plug	-	40F9902	-	X	-	-	1
Surge Protection Adapter	-	53F2627	-	X	X	-	1
Sync Interface Dir Conn 25-Pin Wrap Plug (Port 0-5)	-	33F8968	-	-	X	-	1
Sync Interface Cable	-	15F8868	-	-	X	-	1
V.24 Cable Option	-	16F1888	-	-	X	-	1
V.24 Wrap Plug	-	16F1891	-	-	X	-	1
V.35 15-Pin Wrap Plug (Port 0 & 1, Selectable)	-	40F9900	-	X	-	-	1
V.35 Dir Conn 34 Pin Wrap Plug (Port 0 Only, Selectable)	-	71F0163	-	X	-	-	1
V.35 Cable Option	-	16F1889	-	-	X	-	1
V.35 Elec Interface Brd	-	58X7287	-	X	-	-	1
V.35 Interface Conn Cable	-	67X1249	-	X	-	-	1
V.35 Wrap Plug	-	16F1861	-	-	X	-	1
X.21 15 Pin Wrap Plug (Port 0, Selectable)	-	6425496	-	X	-	-	1
X.21 15 Pin Wrap Plug (Port 0, Selectable)	-	40F9904	-	X	-	-	1
X.21 Cable Option	-	16F1887	-	-	X	-	1
X.21 Wrap Plug	-	16F1890	-	-	X	-	1

Communication (Realtime Interface Options)	Feature Number	FRU Number	Option Number	Industry Standard Architecture (A1-Bus)	Micro Channel Architecture	PCMCIA	Warranty (Years)
X.25 Interface Coproc/2, No Memory	-	44F7123	16F1858	-	X	-	1
X.25 Interface Coproc 37-Pin Wrap Plug	-	16F1884	-	-	X	-	1

Display/Audio Options	Feature Number	FRU Number	Option Number	Industry Standard Architecture	Micro Channel Architecture	PCMCIA	Warranty (Years)
SCSI Micro Channel Adapter	-	69F9731	69F9730	X	-	-	1
ActionMedia II Display Adapter/A 2MB	-	69F9733	69F9732	-	X	-	1
ActionMedia II Capture Option	-	69F9735	69F9734	-	X	-	1
ActionMedia II Video Cable	-	69F9737	-	-	X	-	1
ActionMedia II Audio/Video Capture Cable	-	69F9736	-	-	X	-	1
ActionMedia II Display CD-ROM Cable	-	69F9747	-	-	X	-	1
Display Adapter	-	1887743	1887744	X	-	-	1
Display Adapter 8514/A	-	1887971	1887972	-	X	-	1
Memory Module (for 1887971)	-	1887708	1887989	-	X	-	1
Display Adapter, DBCS (for Japan)	-	07G1459	07G1450	-	X	-	1
Display Adapter (DBCS) (for Taiwan)	-	07G0508	-	-	X	-	1
High-End Audio Kit	3596	-	92G7585	-	-	-	1
CD-ROM Drive	-	71G0297	-	-	-	-	-
Audio Card	-	92G7566	-	-	-	-	-
Speaker Set	-	92G7581	-	-	-	-	-
Joystick	-	92G7555	-	-	-	-	-
Image Adapter/A	-	06G8224	07F4400	-	X	-	1

Display/Audio Options	Feature Number	FRU Number	Option Number	Industry Standard Architecture	Micro Channel Architecture	PCMCIA	Warranty (Years)
Image-I Adapter/A	-	49G2716	-	-	X	-	1
Low-End Audio Kit	3594	-	92G7583	-	-	-	1
CD-ROM Drive	-	71G0297	-	-	-	-	-
Audio Card	-	92G7565	-	-	-	-	-
Speaker Set	-	92G7579	-	-	-	-	-
M-Audio Capture/Playback Adapter/A	-	95F1256	92F3379	-	X	-	1
Mid-Range Audio Kit	3595	-	92G7584	-	-	-	1
CD-ROM Drive	-	71G0297	-	-	-	-	-
Audio Card	-	92G7565	-	-	-	-	-
Speaker Set	-	92G7581	-	-	-	-	-
Joystick	-	92G7555	-	-	-	-	-
MPEG Pro-Motion Video Kit	3597	-	06H4052	-	-	-	1
CD-ROM Drive	-	92G7559	-	-	-	-	-
Speaker Set	-	92G7529	-	-	-	-	-
Real Magic MPEG Board	-	06H4052	-	-	-	-	-
Personal Dictation Adapter (AT/ISA Bus)	-	71G6641	-	X	-	-	1
Screen Reader Adapter	-	33F4842	57F1588	X	-	-	1

Display/Audio Options	Feature Number	FRU Number	Option Number	Industry Standard Architecture	Micro Channel Architecture	PCMCIA	Warranty (Years)
Screen Reader Keypad	-	1393515	1393515	X	X	-	1
Screen Reader Keypad Cable	-	72X8537	72X8537	X	X	-	1
XGA Display Adapter/A	-	96F7657	75X5887	-	X	-	1
Video-Memory Module for XGA (for 96F7657)	-	75X5894	-	-	X	-	1
XGA-2 Display Adapter/A	-	87F4774	87F4773	-	X	-	1

Keyboard/Keypad/Mouse	Feature Number	FRU Number	Option Number	Industry Standard Architecture (AT-Bus)	Micro Channel Architecture	PCMCIA	Warranty (Years)
101-Key Enhanced Keyboard (AT Style)	2290	92G7454	92G7454	X	-	-	1
101-Key Enhanced Keyboard (PS/2 Style)	2289	92G7453	92G7453	-	X	-	1
101-Key Enhanced Keyboard with Trackball (AT Style)	2287	92G7456	92G7456	X	-	-	1
101-Key Enhanced Keyboard with Trackball (PS/2 Style)	2292	92G7455	92G7455	-	X	-	1
101-Key Enhanced Keyboard with TrackPoint II (PS Style)	1943	92G7461	92G7461	-	X	-	1
Adjustable Keyboard - PS/AT Style	2665	13H6713	13H6689	X	X	-	1
Monitor Miser	1948	92G7460	92G7460	X	X	-	3
Enhanced Mouse	2281	92G7457	92G7457	-	X	-	1
Enhanced Mouse II - (Black) PS Style Mouse Port	2671	06H5095	13H6714	X	X	-	1
Enhanced Mouse II - (Pearl White) PS Style Mouse Port	2666	06H4595	13H6690	X	X	-	1
Quiet Touch Numeric Keypad	2285	92G7459	92G7459	X	X	-	1
Quiet Touch Keyboard with TrackPoint II	2282	92G7458	92G7458	-	X	-	1
TrackPoint II Keyboard (Black) - PS Style	3056	13H6710	13H6705	X	X	-	1

Memory	Feature Number	FRU Number	Option Number	Industry Standard Architecture (AT-Bus)	Micro Channel Architecture	PCMCIA	Warranty (Years)
64KB X 1 Memory Module	—	06X8200	—	X	—	—	1
128KB 15ns L2 Cache, for PS/1 2144 and 2168 models with system board FRU 65G4152	3862	92G7548	92G7547	X	—	—	3
128KB L2 Cache Memory (ValuePoint Computers only)	2454	92G7430	92G7228	—	X	—	3
128KB L2 Cache Memory Upgrade (Write Back)	2113	73G3139	92G7220	X	—	—	3
128KB L2 Cache Memory Upgrade (Write Back)	2111	92F0399	92G7217	X	—	—	3
128KB L2 Cache Memory Upgrade (Write Thru)	2109	92F0397	92G7216	X	—	—	3
256KB L2 Cache Memory (ValuePoint Computers only)	2455	92G7431	92G7436	X	—	—	3
256KB L2 Cache Memory Upgrade (Write Back)	2112	92F0400	92G7219	X	—	—	3
256KB L2 Cache Memory Upgrade (Write Back)	2114	73G3231	92G7221	X	—	—	3
256KB X 1 Memory Module	—	76X1022	—	X	—	—	1
512KB 70ns Video Memory (256K x 16 DRAM: 40-Pin ZIP), for PS/1 2133, 2155, and 2168 models	3865	92G7550	92G7551	X	—	—	5
512KB Memory Module	—	53F2658	—	X	—	—	1
512KB Memory Module	—	53F2656	—	—	X	—	1
512KB DRAM (Video)	2106	72G3138	92G7222	X	—	—	3
0-8MB ISA Memory Expansion Adapter (16-Bit)	2200	92G7433	92G7215	X	—	—	3

Memory	Feature Number	FRU Number	Option Number	Industry Standard Architecture (AT-Bus)	Micro Channel Architecture	PCMCIA	Warranty (Years)
1MB 60ns Video Memory (ValuePoint Computers only)	2453	92G7432	92G7443	X	X	-	3
1MB 70ns 30-Pin Industry Standard SIMM	2093	93F0058	92G7197	X	X	-	5
1MB DRAM (Video)	2107	60G2951	92G7223	X	X	-	3
1MB Memory Module	-	53F2662	-	X	-	-	1
1MB Memory Module	-	53F2660	-	-	X	-	1
1MB SRAM PCMCIA Memory Card	2117	0933152	92G7229	-	-	X	3
1MB VRAM (Video)	2108	73G3236	92G7224	X	X	-	3
2MB 70ns 72-Pin IBM SIMM	2087	92F0102	92G7198	X	X	-	5
2MB 85ns 72-Pin IBM SIMM	2202	92F0104	92G7196	X	X	-	5
2MB Flash/1MB SRAM PCMCIA Memory (Combo Card)	2119	0933173	92G7231	-	-	X	3
2MB Flash PCMCIA Memory Card	2115	0932857	92G7225	-	-	X	3
2MB Memory Module	-	53F2664	-	-	X	-	1
2MB SRAM PCMCIA Memory Card	2118	0933155	92G7230	-	-	X	3
4MB 70ns 30-Pin Industry Standard SIMM	2094	96F9289	92G7207	X	X	-	5
4MB 70ns 72-Pin Industry Standard SIMM	2201	73G3233	92G7201	X	X	-	5
4MB 80ns 72-Pin IBM SIMM	2091	92F3337	92G7199	X	X	-	5

Memory	Feature Number	FRU Number	Option Number	Industry Standard Architecture (AT-Bus)	Micro Channel Architecture	PCMCIA	Warranty (Years)
4MB 70ns Non-parity Memory (1M x 32 SIMM: 72-Pin Au), for PS/1 2144 and 2168 models	3479	92G7540	92G7539	X	-	-	3
4MB Flash PCMCIA Memory Card	2116	0932860	92G7226	-	-	X	3
4MB 70ns 72-Pin IBM SIMM	2088	92F0105	92G7200	X	X	-	5
4-14MB Micro Channel Memory Expansion Adapter (32-Bit)	2190	88F0075	92G7214	-	X	-	3
8MB 60ns ECC Memory (1M x 72 DIMM: 3.5v, 168-Pin), PowerPC 8642 models	2638	92G7523	92G7522	X	-	-	5
8MB 70ns ECC 72-Pin IBM SIMM	2098	92F0098	92G7208	X	X	-	5
8MB 70ns 72-Pin IBM SIMM	2089	64F3606	92G7202	X	X	-	5
8MB 72-Pin Industry Standard SIMM	2208	73G3234	92G7203	X	X	-	5
8MB 70ns 72-Pin Industry Standard SIMM (ValuePoint Systems Only)	2647	92G7521	92G7520	X	-	-	5
8MB 70NS 72-Pin Industry Standard SIMM (ValuePoint Computers only)	2637	92G7521	92G7520	X	-	-	5
8MB 70ns 168-Pin Industry Standard DIMM	2100	73G3125	92G7211	X	X	-	5
8MB 70ns Non-parity Memory (1M x 32 SIMM: 72-Pin Au), for PS/1 2144 and 2168 models	3480	92G7542	92G7541	X	-	-	3
8MB 80ns 72-Pin IBM SIMM	2092	64F3607	92G7428	X	X	-	5

Memory	Feature Number	FRU Number	Option Number	Industry Standard Architecture (AT-Bus)	Micro Channel Architecture	PCMCIA	Warranty (Years)
16MB 60ns ECC Memory (2M x 72 DIMM: 3.5v, 168-Pin), PowerPC 8642 models	2639	92G7525	92G7524	X	-	-	5
16MB 70ns 168-Pin Industry Standard DIMM	2104	73G3124	92G7212	X	X	-	5
16MB 70ns ECC 72-Pin IBM SIMM	2097	96F9100	92G7209	X	X	-	5
16MB 70ns 72-Pin Industry Standard SIMM	2211	60G2950	92G7204	X	X	-	5
16MB 70ns Non-parity Memory (4M x 32 SIMM: 72-Pin Au), for PS/1 2144 and 2168 models	3482	92G7544	92G7543	X	-	-	3
32MB 16ns ECC Memory (4M x 72 DIMM: 3.5v, 168-Pin), PowerPC 8642 models	2640	92G7527	92G7526	X	-	-	5
32MB 70ns ECC 72-Pin IBM SIMM	2099	73G3136	92G7210	X	X	-	5
32MB 70ns Non-parity Memory (8M x 32 SIMM: 72-Pin Au), for PS/1 2144 and 2168 models	3483	92G7546	92G7545	X	-	-	3
32MB 70ns Tall 72-Pin Industry Standard SIMM	2095	73G3235	92G7205	X	X	-	5
32MB 70ns Wide 72-Pin Industry Standard SIMM	2096	73G3135	92G7206	X	X	-	5
32MB 70ns 168-Pin Industry Standard DIMM	2105	92G7429	92G7213	X	X	-	5

Memory Options (for System Board Memory)	Feature Number	FRU Number	Option Number	Industry Standard Architecture	Micro Channel Architecture	PCMCIA	Warranty (Years)
256KB Memory Module (for 1497253 - Models 25, 30, 30-286, 50, 55SX, and 57)	-	1497256	30F5348	-	-	-	1
512KB Memory Module (for Type 1 - Model 50)	-	72X8517	-	-	-	-	1
512KB Memory Module (for Type 2 - Model 50)	-	10G4005	-	-	-	-	1
512KB Memory Module Kit (for 53F2603)	-	53F2656	-	-	-	-	1
512KB Memory Module Kit (for 09F1888)	-	16F2267	-	-	-	-	1
512KB Memory Module Kit (for Model 56)	-	16F2226	-	-	-	-	1
0-8MB Expanded Memory Adapter/A (for 50, 55SX, 60, 65)	-	1497253	1497259	-	-	-	1
1MB Memory Module (for 1497253 & 30F5447)	-	74X8637	30F5360	-	-	-	1
1MB Memory Module (85ns, Type 2 & 15F8292)	-	90X8624	6450603	-	-	-	1
1MB Memory Module Kit (for 53F2603)	-	53F2660	-	-	-	-	1
2-8MB 80286 Memory Expansion Option (for 50, 55SX, 60, 65)	-	85F0480	6450609	-	-	-	1
2-8MB 80386 Memory Expansion Adapter (for 70, 80)	-	90X9556	6450605	-	-	-	1
2MB Memory Module Kit (85ns for 90X9556)	-	92F0104	6450604	-	-	-	1
2MB Memory Expansion Adapter (for 25, 30)	-	1497250	2685193	-	-	-	1
2MB Memory Module Kit (Type 2 & 85F0480)	-	90F8625	6450604	-	-	-	1

Memory Options (for System Board Memory)	Feature Number	FRU Number	Option Number	Industry Standard Architecture	Micro Channel Architecture	PCMCIA	Warranty (Years)
2MB Memory Module Kit (for 53F2603)	-	53F2664	&nash.	-	-	-	1
2MB Memory Module Kit (85ns for 90X9566)	-	92F0104	6450604	-	-	-	1
2MB Memory-Module Kit (70ns - for 56, 65, 85, 90, 95, 95A)	-	92F0102	6450902	-	-	-	1
2MB Memory-Module Kit (80ns - for 25, 70, 85, 90, 95, 95A)	-	92F0103	6450608	-	-	-	1
4MB Memory Module Kit (80ns - for 25, 35, 40, 50, 55SX 60, 85, 90, 95, 95A)	-	92F3337	87F9977	-	-	-	1
4MB Memory-Module Kit (70ns - for 56, 85, 90, 95, 95A)	-	92F0105	6450128	-	-	-	1
4MB ECC Memory-Module Kit (70ns - for 85, 90, 95, 95A)	-	92F0097	-	-	-	-	1
8MB Memory Module Kit (70ns - for 40, 56, 85, 90, 95, 95A)	-	64F3606	6450130	-	-	-	1
8MB ECC Memory-Module Kit (70ns - for 85, 90, 95, 95A)	-	92F0098	-	-	-	-	1
8MB Memory Module Kit (80ns - for 40, 85, 90, 95, 95A)	-	64F3607	6450129	-	-	-	1
80286 Memory Expansion Adapter (for 50, 60, 65)	-	72X8532	6450344	-	-	-	1
Memory Module (for 72X8532 - models 50, 65, 70)	-	61X8906	6450345	-	-	-	1
80386 Memory Expansion Adapter (for 70, 80)	-	72X6671	6450367	-	-	-	1
Memory Expansion Kit (for 72X6671 - for 70, 80)	-	72X6672	6450372	-	-	-	1
Enhanced Memory Expansion Option (for 70, 80, 90)	-	88F0075	-	-	-	-	1

Miscellaneous Options	Feature Number	FRU Number	Option Number	Industry Standard Architecture	Micro Channel Architecture	PCMCIA	Warranty (Years)
6157 Tape Adapter	-	37F6718	92X1458	-	X	-	1
Bus Adapter	-	00F2101	-	X	-	-	1
Bus Adapter	-	61X8910	-	X	-	-	1
Bus Adapter (Model 001)	-	27F4864	-	X	-	-	1
Bus Adapter (Model 001)	-	27F4164	-	X	-	-	1
Data Acquisition Adapter (DAC)	-	6181768	6451502	X	-	-	1
Game Control Adapter	-	8529151	1501300	X	-	-	1
GPIO Adapter	-	6181770	6451503	X	-	-	1
Internal Tape Backup Unit	-	87F9787	30F5279	X	X	-	1
Adapter Cable, 34 pin (for 87F9787)	-	34F2717	-	-	X	-	1
Formatted Blank Tape (for 87F9787)	-	30F5277	-	X	X	-	1
Microphone (for UltraMedia* systems)	-	42G2783	-	-	X	-	1
MIDI Adapter Unit	-	81X8624	-	X	-	-	1
Multifunction Adapter	-	30F5447	30F5364	X	-	-	1
1MB Memory Module (for 1497253 & 30F5447)	-	74X8637	30F5360	X	-	-	1
PC Music Feature	-	81X8620	81X8630	X	-	-	1
Serial/Parallel Adapter	-	8286147	6450215	X	-	-	1

Miscellaneous Options	Feature Number	FRU Number	Option Number	Industry Standard Architecture	Micro Channel Architecture	PCMCIA	Warranty (Years)
Serial Adapter Cable	-	8286170	6450217	X	-	-	1
Serial Adapter Connector	-	8286194	6450242	X	-	-	1
Speech Adapter	-	61X8921	1501216	X	-	-	1
Speech/Jewer Adapter	-	15F8511	6450610	X	-	-	1
Pageprinter Adapter	-	75X8213	75X8627	-	X	-	1
Printer Accessory Kit	-	1183003	-	-	X	-	1
Printer Cable	-	8529214	1525612	X	-	-	1
Print Service Adapter	-	99F4371	-	-	X	-	1
Screw Kit (PS/2)	-	92F0141	-	-	X	-	1
Tape Cover Plate	-	87F9767	-	-	X	-	1

Multimedia	Feature Number	FRU Number	Option Number	Industry Standard Architecture (AT-Bus)	Micro Channel Architecture	PCMCIA	Warranty (Years)
Audiovation ISA Adapter	2079	52G7224	92G7463	X	-	-	1
Audiovation Micro Channel Adapter	2080	65G8863	92G7464	-	X	-	1
Audiovation Kit	2081	-	92G7465	X	X	-	1
ISA Adapter	-	52G7224	-	-	-	-	-
Panasonic CD-ROM Cables (MIDI Pack)	-	61G4109	-	-	-	-	-
Jazz16 Multimedia Audio Adapter (ValuePoint only)	2082	92G7466	92G7466	X	X	-	1
Jazz16 Audio Card	2631	-	92G7528	X	-	-	1
Audio/Data Cable	-	06H3086	-	-	-	-	-
Microphone	-	06H3085	-	-	-	-	-
Speaker	-	06H3616	-	-	-	-	-
Speaker	-	06H3614	-	-	-	-	-
Speaker Transformer (US)	-	06H3615	-	-	-	-	-
Jazz16 Upgrade Kit (ValuePoint only)	2632	-	92G7531	X	-	-	1
Jazz16 Audio Card	-	06H3086	-	-	-	-	-
CD-ROM Drive	-	61G4109	-	-	-	-	-
Personal Dictation System Adapter	-	71G6641	-	X	-	-	1
Personal Dictation System Adapter	-	71G6642	-	-	X	-	1

Storage Device (Adapter)	Feature Number	FRU Number	Option Number	Industry Standard Architecture	Micro Channel Architecture	PCMCIA	Warranty (Years)
16-Bit AT SCSI Adapter	1963	82G4879	70G8496	X	-	-	3
32-Bit SCSI Adapter	1968	92F0160	70G8498	-	X	-	3
360KB or 1.2MB Diskette Adapter/A	-	15F7996	6451007	-	X	-	1
360KB External Diskette Adapter/A	-	72X6758	6450245	-	X	-	1
Diskette Drive Bus Adapter	-	72X8524	-	-	X	-	1
External Diskette Drive Adapter	-	72X6757	6450244	X	-	-	1
Fixed Disk Adapter (Model 021 only, for 72X8522)	-	72X8505	-	-	X	-	1
Fixed Disk Adapter (Model 021/061)	-	90X94410	-	-	X	-	1
Fixed Disk Adapter (Model 021 only, for 6128294)	-	90X9571	-	-	X	-	1
Fixed Disk and Diskette Drive Bus Adapter	-	90X9287	-	-	X	-	1
Fixed Disk Adapter (ESDI)	-	92F0061	-	-	X	-	1
Fixed Disk Adapter (ST506)	-	72X8540	-	-	X	-	1
SCSI-2 VL-Bus Adapter	1922	71G0410	70G8482	X	-	-	3
Cable (Internal)	-	71G0711	-	-	-	-	-
SCSI Micro Channel Adapter	1966	85F0063	70G8497	-	X	-	3

Storage Device (DASD)	Feature Number	FRU Number	Option Number	Industry Standard Architecture (AT-Bus)	Micro Channel Architecture	PCMCIA	Warranty (Years)
3.5" 1.44MB Diskette Drive	1969	93F2361	70G8499	X	X	-	1
3.5" 2.88MB Diskette Drive	5095	82G1887	32G4338	X	-	-	1
3.5" 127MB External Rewritable Optical Drive	2084	66G7510	62G2908	X	X	-	1
3.5" 127MB External Rewritable Optical Drive (Type 3432, Model 705)	-	66G7510	62G2911	X	X	-	1
127MB Rewritable Optical Drive	-	66G7510	-	X	X	-	1
External Power Supply	-	62G2919	-	X	X	-	1
Cable Assembly	-	49G6682	-	X	X	-	1
Circuit Card	-	49G6683	-	X	X	-	1
Fan Assembly	-	49G6685	-	X	X	-	1
1GB AT Hard Disk Drive	2543	71G0686	70G8512	X	X	-	1
1GB High Performance Fast/Wide SCSI-2 Hard Disk Drive (EMEA only)	2673	06H3371	94G3052	-	-	-	5
1GB Value AT Hard Disk Drive	3955	06H6111	94G3183	X	-	-	3
1.3GB External Rewritable Optical Drive (Type 3431, Model 705)	-	-	62G2910	X	X	-	1
1.3GB Rewritable Optical Drive	-	61G9312	-	X	X	-	1
Filter Assembly	-	46G2251	-	X	X	-	1

Storage Device (DASD)	Feature Number	FRU Number	Option Number	Industry Standard Architecture (AT-Bus)	Micro Channel Architecture	PCMCIA	Warranty (Years)
Power Supply	-	49G6654	-	X	X	-	1
Card Assembly	-	55F9553	-	X	X	-	1
Fan Assembly	-	55F9421	-	X	X	-	1
1.3GB Rewritable Optical Drive	2085	49G6658	62G2929	X	X	-	1
230MB Optical Disk Drive, SCSI	3484	-	05H2794	-	-	-	1
Optical Drive	-	05H2005	-	-	-	-	-
Cleaner	-	66G7444	-	-	-	-	-
2GB High Performance Fast SCSI2 Hard Disk Drive	2675	06H3370	94G3054	-	-	-	5
2GB High Performance Fast/Wide SCSI-2 Hard Disk Drive	2677	06H3372	94G3055	-	-	-	5
4/10GB 3.5" 4MM Digital Audio Tape (DAT) SCSI Option	1993	-	74G8632	X	X	-	2
4/10GB 3.5" DAT Tape Drive (SCSI)	-	16G8456	-	-	-	-	-
4MM Media Kit (DDS2)	-	8191149	-	-	-	-	-
- Cleaning Cartridge	-	21F8763	-	-	-	-	-
- Data Cartridge	-	8191160	-	-	-	-	-
- Diagnostic Cartridge	-	8191146	-	-	-	-	-
Bezel Kit (3.5" Drive)	-	8191271	-	-	-	-	-
Cable (Power Cable for Server 95A)	-	74G8335	-	-	-	-	-

Storage Device (DASD)	Feature Number	FRU Number	Option Number	Industry Standard Architecture (AT-Bus)	Micro Channel Architecture	PCMCIA	Warranty (Years)
Micro Channel Card Handle	-	8191273	-	-	-	-	-
Slide Assembly	-	8191272	-	-	-	-	-
5MB PCMCIA Solid State File Card	2534	40G3171	40G3166	-	-	X	1
10MB PCMCIA Solid State File Card	2535	40G3173	40G3167	-	-	X	1
20MB PCMCIA Solid State File Card	2536	40G3174	40G3168	-	-	X	1
30MB PCMCIA Solid State File Card	2537	40G3175	40G3169	-	-	X	1
40MB Hard Disk Drive (PCMCIA)	1962	-	70G8495	-	-	X	1
40MB Hard Disk Drive (PCMCIA)	-	71G6426	-	-	-	X	1
PCMCIA Hard Disk Drive Pull Tab	-	82G6124	-	-	-	-	-
Carrying Case	-	92F0430	-	-	-	-	-
40MB PCMCIA Solid State File Card	2538	40G3176	40G3170	-	-	X	1
4/10GB 5.25" 4MM Digital Audio Tape (DAT) SCSI Option	1994	-	74G8631	X	X	-	2
4/10GB 5.25" DAT Tape Drive (SCSI)	-	16G8454	-	-	-	-	-
Bezel Kit (for Models 57, 77, 85, 90, 95, and 3511)	-	55F9554	-	-	-	-	-
Bezel Kit (for Models 60 and 80)	-	55F9557	-	-	-	-	-
Cable (Power Cable for Models 60 and 80)	-	72X8521	-	-	-	-	-
Cable (SCSI Adapter 68 to 50-Pin)	-	92F0324	-	-	-	-	-

Storage Device (DASD)	Feature Number	FRU Number	Option Number	Industry Standard Architecture (AT-Bus)	Micro Channel Architecture	PCMCIA	Warranty (Years)
Cable (SCSI Extender Cable for Models 60 and 80)	-	46G2330	-	-	-	-	-
Cable (SCSI ID Cable for Model 3510)	-	8191274	-	-	-	-	-
4MM Media Kit	-	8191149	-	-	-	-	-
- Cleaning Cartridge	-	21F8763	-	-	-	-	-
- Data Cartridge	-	8191160	-	-	-	-	-
- Diagnostic Cartridge	-	8191146	-	-	-	-	-
Rail Kit (for Models 60, 80, 95, 3510, and 3511)	-	55F9559	-	-	-	-	-
Rail Kit (for Models 57 and 77)	-	55F9560	-	-	-	-	-
Slide Assembly (for Model 90)	-	55F9563	-	-	-	-	-
5.25" 1.2MB Diskette Drive	1970	82G1824	70G8500	X	X	-	1
105MB Hard Disk Drive (PCMCIA)	5346	-	32G4199	-	-	X	1
105MB Hard Disk Drive (PCMCIA)	-	92F0429	-	-	-	X	1
PCMCIA Hard Disk Drive Pull Tab	-	82G6124	-	-	-	-	-
Carrying Case	-	92F0430	-	-	-	-	-
170MB SCSI Hard Disk Drive	1920	71G6550	70G8480	X	X	-	2
270MB IDE Hard Disk Drive	1928	82G5926	70G8487	X	X	-	2
250 DualStor Internal Tape Backup Unit	7094	82G7106	82G7094	X	-	-	2

Storage Device (DASD)	Feature Number	FRU Number	Option Number	Industry Standard Architecture (AT-Bus)	Micro Channel Architecture	PCMCIA	Warranty (Years)
250 DualStor PS/2 Installation Kit (contains DualStor installation software for PS/2 computers)	7092	-	82G7092	X	-	-	1
Bezel	-	82G7107	-	-	-	-	-
34-Pin to Card Edge Connector	-	82G7108	-	-	-	-	-
Adapter/Cable Bracket	-	92G5039	-	-	-	-	-
80MB Tape Cartridge	-	30F5277	-	-	-	-	-
364MB External PCMCIA Hard Disk Drive (Machine Type 3513, Model 364)	-	-	66G3369	X	X	-	2
364MB Hard Disk Drive	-	66G3371	-	-	-	-	-
PCMCIA Interface Card	-	66G3353	-	-	-	-	-
270MB Fast SCSI-2 Hard Disk Drive	3486	82G5930	94G2439	X	X	-	2
340MB SCSI Hard Disk Drive	1921	71G6551	70G8481	X	X	-	2
364MB IDE Hard Disk Drive	1929	82G5927	70G8488	X	X	-	2
364MB Fast SCSI-2 Hard Disk Drive	3490	82G5931	94G2440	X	X	-	2
527MB Hard Disk Drive	-	66G3372	-	-	-	-	-
527MB External PCMCIA Hard Disk Drive (Machine Type 3513, Model 527)	-	-	66G3370	X	X	-	2
PCMCIA Interface Card	-	66G3353	-	-	-	-	-

Storage Device (DASD)	Feature Number	FRU Number	Option Number	Industry Standard Architecture (AT-Bus)	Micro Channel Architecture	PCMCIA	Warranty (Years)
527MB IDE Hard Disk Drive	1926	84G6108	70G8486	X	X	-	2
540MB SCSI Hard Disk Drive	1952	92F0406	70G8491	X	X	-	2
540MB Fast SCSI-2 Hard Disk Drive	3491	82G5932	94G2441	X	X	-	2
728MB Fast SCSI-2 Hard Disk Drive	3492	82G5933	94G2442	X	X	-	2
728MB IDE Hard Disk Drive	1989	82G5929	70G8511	X	X	-	2
1GB SCSI-2 Hard Disk Drive	1958	92F0428	70G8492	X	X	-	5
1GB SCSI Fast/Wide Hard Disk Drive Assembly (with 68 Position Tray Assembly)	2803	-	70G9743	-	-	X	5
1GB SCSI Fast/Wide Hard Disk Drive	-	71G5040	-	-	-	-	-
1GB SCSI Fast/Wide Hard Disk Drive Address Cable	-	71G0215	-	-	-	-	-
68 Position Tray Assembly	-	71G0212	-	-	-	-	-
1.2GB 1/4" Tape Drive (Model 3450-001)	-	-	74G8630	X	X	-	1
1.2GB 1/4" Tape Drive	-	8191184	-	-	-	-	-
Cable (Internal SCSI)	-	74G8273	-	-	-	-	-
Cable (Option-to-Option) (US)	-	31F4222	-	-	-	-	-
Cable (Option-to-Option) (WT)	-	8191252	-	-	-	-	-
Cable (AT SCSI Adapter) (US)	-	32G0397	-	-	-	-	-

Storage Device (DASD)	Feature Number	FRU Number	Option Number	Industry Standard Architecture (AT-Bus)	Micro Channel Architecture	PCMCIA	Warranty (Years)
Cable (AT SCSI Adapter) (WT)	-	8191287	-	-	-	-	-
Cable (SCSI Address)	-	8191200	-	-	-	-	-
Cable (System-to-50-Pin Standard Connector Option) (US)	-	74G8626	-	-	-	-	-
Cable (System-to-50-Pin Standard Connector Option) (WT)	-	74G8629	-	-	-	-	-
Cable (System-to-Option) (US)	-	31F4221	-	-	-	-	-
Cable (System-to-Option) (WT)	-	8191251	-	-	-	-	-
Cable (System-to-SCSI-2 Fast/Wide Adapter) (US)	-	52G4231	-	-	-	-	-
Cable (System-to-SCSI-2 Fast/Wide Adapter) (WT)	-	74G8612	-	-	-	-	-
Chassis (with Feet)	-	74G8274	-	-	-	-	-
Cover (Top)	-	74G8224	-	-	-	-	-
Cradle	-	46G3982	-	-	-	-	-
Fan	-	55F9421	-	-	-	-	-
Foot Assembly (Chassis)	-	02G7413	-	-	-	-	-
Guard (Fan)	-	55F9393	-	-	-	-	-
Logo	-	46G3984	-	-	-	-	-
Nut (Fan)	-	1622401	-	-	-	-	-
Power Supply	-	8191380	-	-	-	-	-

Storage Device (DASD)	Feature Number	FRU Number	Option Number	Industry Standard Architecture (AT-Bus)	Micro Channel Architecture	PCMCIA	Warranty (Years)
Screw	-	46G2677	-	-	-	-	-
Screw (Fan)	-	46G2698	-	-	-	-	-
Screw (SCSI connector)	-	0251970	-	-	-	-	-
Toroid	-	59F4585	-	-	-	-	-
Washer (Fan)	-	1622344	-	-	-	-	-
Terminator (Active 8-Bit)	-	92F0057	-	-	-	-	-
Test Tape	-	21F8734	-	-	-	-	-
2GB SCSI 8-Bit SCSI-2 Hard Disk Drive	1959	92F0440	70G8493	X	X	-	5
2GB SCSI 16-Bit SCSI-2 Hard Disk Drive	1961	92F0407	70G8494	X	X	-	5
5/10GB 8mm Tape Drive (Model 3445-001)	-	-	74G8629	X	X	-	1
5GB 8mm Tape Drive	-	46G2542	-	-	-	-	-
Cable (AT SCSI Adapter)	-	32G0397	-	-	-	-	-
Cable (Internal SCSI)	-	74G8273	-	-	-	-	-
Cable (Option-to-Option)	-	31F4222	-	-	-	-	-
Cable (SCSI Address)	-	8191200	-	-	-	-	-
Cable (System-to-Option)	-	31F4221	-	-	-	-	-
Cable (System-to-SCSI-2 Fast/Wide Adapter)	-	52G4231	-	-	-	-	-

Storage Device (DASD)	Feature Number	FRU Number	Option Number	Industry Standard Architecture (AT-Bus)	Micro Channel Architecture	PCMCIA	Warranty (Years)
Chassis (with Feet)	-	74G8274	-	-	-	-	-
Cleaning Cartridge	-	21F8593	-	-	-	-	-
Cover (Top)	-	74G8177	-	-	-	-	-
Cradle	-	46G3982	-	-	-	-	-
Data Cartridge	-	21F8575	-	-	-	-	-
Fan	-	55F9421	-	-	-	-	-
Foot Assembly (Chassis)	-	02G7413	-	-	-	-	-
Guard (Fan)	-	55F9393	-	-	-	-	-
Logo	-	46G2644	-	-	-	-	-
Nut (Fan)	-	1622401	-	-	-	-	-
Power Supply	-	8191380	-	-	-	-	-
Screw	-	46G2677	-	-	-	-	-
Screw (Fan)	-	46G2698	-	-	-	-	-
Screw (SCSI Connector)	-	0251970	-	-	-	-	-
Terminator (Active 8-Bit)	-	92F0057	-	-	-	-	-
Tonoid	-	59F4585	-	-	-	-	-
Washer (Fan)	-	1622344	-	-	-	-	-

Storage Device (DASD)	Feature Number	FRU Number	Option Number	Industry Standard Architecture (AT-Bus)	Micro Channel Architecture	PCMCIA	Warranty (Years)
Enhanced SCSI Internal CD-ROM II	1983	61G1901	70G8503	X	X	-	1
Bezel (for Models 40, 57, and 77)	-	85F0008	-	-	-	-	-
Bezel (for Models 60, 65, and 80)	-	34F0044	-	-	-	-	-
Bezel (for Model 95)	-	64F0138	-	-	-	-	-
Cable (Power Cable for Models 60 and 80)	-	72X8521	-	-	-	-	-
Cable (Remote Add Switch)	-	92F0086	-	-	-	-	-
Cable (Signal Cable 60/80)	-	34F0043	-	-	-	-	-
CD Caddy	-	22F9419	-	-	-	-	-
Ground Bracket (for Models 60 and 80)	-	85F0010	-	-	-	-	-
Grounding Springs	-	92F0087	-	-	-	-	-
Headphones	-	53F3610	-	-	-	-	-
Media Kit	-	31F4232	-	-	-	-	-
Miscellaneous Parts Kit	-	92F0010	-	-	-	-	-
Rail Kit (for Model 8585 and Models 3510)	-	34F0041	-	-	-	-	-
Terminator/Jumper Kit	-	92F0082	-	-	-	-	-
External Enhanced CD-ROM II (Type 3510, Model 705)	-	-	70G8504	X	X	-	1
Base	-	85F0072	-	-	-	-	-

Storage Device (DASD)	Feature Number	FRU Number	Option Number	Industry Standard Architecture (AT-Bus)	Micro Channel Architecture	PCMCIA	Warranty (Years)
Cable (Remote Add Switch Cable)	-	92F0086	-	-	-	-	-
Cable (Signal Cable)	-	92F0009	-	-	-	-	-
External Cover	-	85F0027	-	-	-	-	-
Power Supply	-	85F0051	-	-	-	-	-
CD Caddy	-	22F9419	-	-	-	-	-
CD-ROM II Drive	-	61G1901	-	-	-	-	-
Headphones	-	53F3610	-	-	-	-	-
Media Kit	-	31F4232	-	-	-	-	-
Miscellaneous Parts Kit	-	92F0010	-	-	-	-	-
Rail Kit 8585/3510	-	34F0041	-	-	-	-	-
Terminator/Jumper Kit	-	92F0082	-	-	-	-	-
Fixed Disk Adapter (Model 021 only, for 72X8522)	-	72X8505	-	-	X	-	1
Fixed Disk Adapter (Model 021/061)	-	90X94410	-	-	X	-	1
Fixed Disk Adapter (Model 021 only, for 6128294)	-	90X9571	-	-	X	-	1
Fixed Disk and Diskette Drive Bus Adapter	-	90X9287	-	-	X	-	1
Fixed Disk Adapter (ESDI)	-	92F0061	-	-	X	-	1
Fixed Disk Adapter (ST506)	-	72X8540	-	-	X	-	1

Storage Device (DASD)	Feature Number	FRU Number	Option Number	Industry Standard Architecture (AT-Bus)	Micro Channel Architecture	PCMCIA	Warranty (Years)
IBM 127MB Rewritable Optical Drive	2084	66G7510	62G2908	X	X	-	1
ISA Internal CD-ROM Drive	1980	61G4109	70G8501	X	-	-	1
Cable (Data)	-	61G4111	-	-	-	-	-
Cable (Audio)	-	61G4112	-	-	-	-	-
Internal Adapter Card	-	61G4110	-	-	-	-	-
ISA External CD-ROM (Type 3509, Model 701)	-	-	70G8502	X	-	-	1
Cable (External Drive)	-	61G4115	-	-	-	-	-
ISA CD-ROM Drive	-	61G4109	-	X	-	-	-
External CD-ROM Enclosure	-	82G6461	-	-	-	-	-
External Adapter Card	-	61G4114	-	-	-	-	-
IDE 2X CD-ROM Drive	3589	-	70G8519	X	-	-	1
CD-ROM Drive	-	06H6152	-	-	-	-	-
Audio Cable	-	06H2944	-	-	-	-	-
IDE Cable	-	52G8749	-	-	-	-	-
Internal SCSI 2X CD-ROM	3588	-	94G2686	X	X	-	1
CD-ROM Drive	-	88G4898	-	-	-	-	-
Audio Cable	-	06H5053	-	-	-	-	-

Storage Device (DASD)	Feature Number	FRU Number	Option Number	Industry Standard Architecture (AT-Bus)	Micro Channel Architecture	PCMCIA	Warranty (Years)
Power Cable	-	33F8431	-	-	-	-	-
Diagnostic CD	-	31F4232	-	-	-	-	-
Model 3432 Optical Disk Drive, SCSI (US/Canada)	-	-	05H2784	-	-	-	1
Optical Drive	-	05H2005	-	-	-	-	-
Power Supply	-	05H2785	-	-	-	-	-
SCSI Cable	-	49G6682	-	-	-	-	-
Circuit Card	-	49G6683	-	-	-	-	-
Fan	-	49G6685	-	-	-	-	-
Cleaner	-	66G7444	-	-	-	-	-
Model 3432 Optical Disk Drive, SCSI (EMEA/Latin America)	-	-	05H3414	-	-	-	1
Optical Drive	-	05H2005	-	-	-	-	-
Power Supply	-	05H2785	-	-	-	-	-
SCSI Cable	-	49G6682	-	-	-	-	-
Circuit Card	-	49G6683	-	-	-	-	-
Fan	-	49G6685	-	-	-	-	-
Cleaner	-	66G7444	-	-	-	-	-

Storage Device (DASD)	Feature Number	FRU Number	Option Number	Industry Standard Architecture (A-T-Bus)	Micro Channel Architecture	PCMCIA	Warranty (Years)
Model 3510 Storage Enclosure Hard Disk Drive Kit B (for Hard Disk Drive Options Numbers 70G8480, 70G8481, 70G8492, 70G8493)	3590	61G2390	94G2648	-	X	-	1
Model 3510 Storage Enclosure Hard Disk Drive Kit B (for Hard Disk Drive Options Numbers 94G2439, 94G2440, 94G2441, 94G2442)	3590	06H4685	94G2648	-	X	-	1
PS/2 3510 Hard Disk Drive Kit (contains cables for 170MB, 340MB, 1.0GB, and 2.0GB Fast SCSI-2 Hard Disk Drives)	0263	61G2390	70G8507	-	-	-	1
PS/2 Desk Top Hard Disk Drive Kit	0261	-	70G8505	X	X	-	1
Slide (for Models 35, 40, 56, 57, 76 and 77)	-	96F7775	-	-	-	-	-
Tray (for Models 40, 57, and 77)	-	64F0141	-	-	-	-	-
Bezel (for Models 40, 57, and 77)	-	85F0094	-	-	-	-	-
Slide (for Model 90)	-	85F0035	-	-	-	-	-
Bezel (for Model 90)	-	85F0052	-	-	-	-	-
PS/2 Floor Standing Hard Disk Drive Kit	0262	-	70G8506	-	X	-	1
Trays (for Models 85, 95, and 3511)	-	64F0141	-	-	-	-	-
Bezel Shields (3), EMC Spring (1) (for Models 85, 95, and 3511)	-	92F0255	-	-	-	-	-
PS/2 Rewritable Optical Drive Installation Kit	2539	-	05H2762	-	X	-	1

Storage Device (DASD)	Feature Number	FRU Number	Option Number	Industry Standard Architecture (AT-Bus)	Micro Channel Architecture	PCMCIA	Warranty (Years)
Bezel (Models 40, 56, 57, and 77)	-	85F0008	-	-	-	-	-
Bezel (Models 60, 65, and 80)	-	34F0044	-	-	-	-	-
Bezel (Models 95 and 3511)	-	64F0138	-	-	-	-	-
Rail Kit (Models 60, 65, and 80)	-	34F0041	-	-	-	-	-
Rail Kit with Springs (Models 95 and 3511)	-	85F0009	-	-	-	-	-
Rewritable Optical Drive, 3.5-Inch	-	92F0167	6450162	-	X	-	1
SCSI Fast Adapter (16 Bit AT)	-	92F0330	-	X	-	-	1
SCSI External Cable (for 92F0330)	-	32G4089	-	X	-	-	1
SCSI Internal Cable (for 92F0330)	-	37G0084	-	X	-	-	1
SCSI Adapter/A (with Cache)	-	85F0063	6451133	-	X	-	1
SCSI Adapter/A (without Cache)	-	85F0002	6451109	-	X	-	1
SCSI Cable (Internal)	-	64F4127	-	-	X	-	1
SCSI-2 Fast/Wide Adapter/A	-	92F0160	6451280	-	X	-	1
SCSI-2 Fast/Wide 16-Bit Internal Cable (68 to 68 pin) (for 92F0160)	-	92F0327	32G3922	-	X	-	1
SCSI-2 Fast/Wide 16-Bit Internal Cable (68 to 68 pin) (for 92F0160)	-	61G3511	32G3921	-	X	-	1

Storage Device (DASD)	Feature Number	FRU Number	Option Number	Industry Standard Architecture (AT-Bus)	Micro Channel Architecture	PCMCIA	Warranty (Years)
SCSI-2 Fast/Wide 8-Bit Internal Cable (50 to 50 pin) (for 85F0063, 85F0002, 92F0160)	-	61G3005	32G3098	-	X	-	1
SCSI-2 Fast/Wide 8-Bit Internal Cable (50 to 50 pin) (for 85F0063, 85F0002, 92F0160)	-	61G3508	32G3097	-	X	-	1
SCSI-2 Fast/Wide Card to SCSI-2 Fast/Wide Option Cable (68 to 68 pin, Long) (for 92F0160)	-	92F0326	32G3913	-	X	-	1
SCSI-2 Fast/Wide Card to SCSI-2 Fast/Wide Option Cable (68 to 68 pin, Short) (for 92F0160)	-	92F0441	32G3914	-	X	-	1
SCSI-2 Fast/Wide Card to SCSI Option Cable (68 to 50 pin, Long) (for 92F0160)	-	92F0321	32G3915	-	X	-	1
SCSI-2 Fast/Wide Card to SCSI Option Cable (68 to 50 pin, Short) (for 92F0160)	-	92F0442	32G3916	-	X	-	1
SCSI Option to SCSI Option Cable (50 to 50 pin, Short) (for 85F0063, 85F0002, 92F0160)	-	92F0325	32G3917	-	X	-	1
SCSI Internal Converter (16-bit to 8-bit, 68 to 50 pin) (for 92F0160)	-	92F0324	32G3925	-	X	-	1
SCSI Card to Option Cable (60 to 50 pin, Long) (for 85F0063, 85F0002)	-	34F0017	32G4143	-	X	-	1
SCSI-2 Card to Single Port SCSI Option Cable (68 to 50 pin, Long) (for 92F0160)	-	71G2590	32G3099	-	X	-	1

Storage Device (DASD)	Feature Number	FRU Number	Option Number	Industry Standard Architecture (AT-Bus)	Micro Channel Architecture	PCMCIA	Warranty (Years)
SCSI-2 Fast/Wide 16-Bit Active Terminator (68 pin) (for 92F0160)	-	92F0432	32G3918	-	X	-	1
SCSI-2 Fast/Wide 8-Bit Active Terminator (50 pin) (for 85F0063, 85F0002, 92F0160)	-	92F0057	32G3919	-	X	-	1
Optical Lens Cleaning Cartridge (for 92F0167)	-	38F8681	-	-	-	-	1
Terminator (for 85F0002)	-	57F2870	-	-	X	-	1
Terminator (for 92F0167)	-	92F0269	-	-	-	-	1
Terminator, External (for 85F0063)	-	33F8464	6451039	-	-	-	1
Terminator, Inline (space permitting)	-	92F0142	-	-	-	-	1
Terminator, Internal (for 85F0063)	-	92F0057	-	-	-	-	1
Terminator, Internal (for 85F0063)	-	33F0478	-	-	-	-	1

Processor Options	Feature Number	FRU Number	Option Number	Industry Standard Architecture	Micro Channel Architecture	PCMCIA	Warranty (Years)
486DX33 Processor Upgrade (for Model 70)	-	92F0436	-	-	-	-	1
486DX33 Processor Upgrade (for Model 80)	-	92F0437	-	-	-	-	1
8087 Math Coprocessor (for models 25 and 30)	-	61X8922	1501217	-	-	-	1
80287 Math Coprocessor (for models 35-286, 50, and 60)	-	72X8528	6450356	-	-	-	1
80387SX Math Coprocessor, 16MHz (for 55SX, 65)	-	33F8160	27F4676	-	-	-	1
80387 Coprocessor, 16MHz (for Model 70)	-	72X6673	6450369	-	-	-	1
80387 Coprocessor, 20MHz (for Model 70)	-	90X7393	6450378	-	-	-	1
Adapter Cable 34 pin (for 87F9787)	-	34F2717	-	-	-	-	1
Alt. microprocessor (Overdrive 25/50MHz - for 9576, 9577)	-	92F0147	-	-	-	-	1
Alt. microprocessor (Overdrive 33/66MHz - for 85, 9576, 9577)	-	92F2582	-	-	-	-	1

System Board Memory (for Memory Options)	Feature Number	FRU Number	Option Number	Industry Standard Architecture	Micro Channel Architecture	PCMCIA	Warranty (Years)
64KB Memory Module (ZM1, ZM2 - for 25, 25-286, 25SX)	-	00F2120	-	-	-	-	1
64KB Memory Module (U16, U22, U34, U35 - for 25, 25-286, 25SX)	-	00F2121	-	-	-	-	1
256KB Memory Module (for 25, 25-286, 25SX, 30, 60, 65, 80)	-	61X8906	-	-	-	-	1
256KB Memory Pack (for 25, 25-286, 25SX, 30-286)	-	1497256	-	-	-	-	1
512KB Memory Module (for Model 50-021)	-	72X8517	-	-	-	-	1
1MB Memory Kit (for 33F8416)	-	72X6670	-	-	-	-	1
1MB Memory Pack (for 25, 25-286, 25SX, 30-286)	-	74X8637	-	-	-	-	1
1MB Parity Memory Module Kit (85ns - for 25, 25-286, 25SX, 35, 40, 55SX, 80, 95)	-	90X8624	-	-	-	-	1
1MB Parity Memory-Module Kit (85ns) (Model 95, Type 1 & 3 Processor Boards)	-	90X8624	-	-	-	-	1
2MB Parity Memory Module Kit (70ns)	-	92F0102	-	X	X	-	1
2MB Parity Memory Module Kit (80ns)	-	92F0103	-	X	X	-	1
2MB Parity Memory Module Kit (85ns) (Type 1 & 3 Processor Boards)	-	92F0104	-	X	X	-	1
2MB Memory Kit (for 92F0756)	-	92F0669	-	-	-	-	1

System Board Memory (for Memory Options)	Feature Number	FRU Number	Option Number	Industry Standard Architecture	Micro Channel Architecture	PCMCIA	Warranty (Years)
4MB Parity Memory-Module Kit (80ns - for 90, 95)	-	87F9980	-	-	-	-	1
4MB ECC Memory-Module Kit (70ns) (Type 3 Boards only - for Models 90, 95, and 95A)	-	92F0097	-	-	-	-	1
4MB Parity Memory Module Kit (70ns)	-	92F0105	-	X	X	-	1
4MB Memory Kit (for 85F0046 - for Models 60, 65, and 80)	-	92F0106	-	-	-	-	1
4MB Memory Module Kit	-	92F3337	-	X	X	-	1
8MB Parity Memory Module Kit (70ns)	-	64F3606	-	X	X	-	1
8MB Parity Memory Module Kit (80ns)	-	64F3607	-	X	X	-	1
8MB ECC Memory-Module Kit (70ns) (Type 3 Boards only - for Models 90, 95, and 95A)	-	92F0098	-	-	X	-	1
16MB ECC Memory-Module Kit (70ns - for 95, 95A)	-	92F0100	-	-	-	-	1

Hardware Maintenance Reference

Safety Information	365
General Safety	365
Electrical Safety	366
Safety Inspection Guide	368
Handling Electrostatic Discharge-Sensitive Devices	369
Grounding Requirements	369
Drive and Diskette Compatibility Matrix	370
Hard Disk Drive Settings (ATA)	371
Preparing a Hard Disk for Moving	374
Security	375
U-Bolt	375
Cover Lock and Tamper-Evident Switches	375
Rear-Panel Security Option	375
Passwords	376
Additional Override Jumper Functions	378
Privileged-Access Password	378
Power-on Features	380
System Features	380
Microprocessors	380
Processor Boards (70)	380
Processor Boards (90, 95)	380
NVRAM and NVRAM Extension	381
POST Overview	381
Reference and Diagnostic Diskettes	383
Accessing System Programs and Starting Diagnostic Tests	384
QAPLus/PRO Diagnostics	386
Using the Test Programs	389
Using the System Utilities	393
Disk Array System	396
Recording the Vital Product Data on a New System Board	400
Upgradable POST and BIOS	400
PCMCIA Adapter (Model 33)	400
Video	401
Non-IBM Displays	402
Serial Port	403
Parallel Port	404
Supported Cables	404
Diskette-Drive Controller	404
Keyboard and Pointing-Device Connectors	404
System Memory	405
System-Board Memory	405
Memory-Expansion Adapters	405
Memory Errors	405
Unique Memory Information (90, 95)	406
Model 90 Memory	406
Model 95 Memory	406
Memory Configurations (90, 95)	407
Error Detection (90, 95)	407

Resolving Memory-Address Conflicts	408
Changing the Software Configuration	408
Changing the System Configuration	408
SCSI System Information	409
SCSI Hard Disk Drives and Devices	409
Understanding SCSI ID Numbers	409
Selecting a SCSI ID	409
Setting a SCSI ID	411
Optical-Head Lens Cleaning Procedure	413
Setting the Motor-Start Jumper	414
Terminator Function	414
16-Bit AT Fast SCSI Adapter Switch Settings	415
Interrupt Settings	415
Memory Address Switch Settings	415
I/O Address	416
Selectable Drive-Startup Function	420
System-Unit Power Supplies	422
Power-Supply Features	422
System Partition	425
Starting System Program Diagnostics	425
Updating the System Programs	426
Upgrading the System Partition Version	426
Backing up the System Partition	427
Restoring the System Partition	428
Running Automatic Configuration	429
Recording a Customized Configuration	429
ASCII Terminals	430
ASCII Terminal Setup and Menu Selection	430
ASCII Terminal Configuration	431
System Error Log	433
Viewing the Error Log	433
Types of Errors Detected	433
Error Storage	434
Application	434
Dumping Extended Diagnostic Data Information	434
PS/2 System Specifications	435
PS/2 - AT Bus	435
PS/2 - Micro Channel (Non IML)	436
PS/2 - Micro Channel (IML)	437
Acronyms, Abbreviations, and Terms	438
We Want Your Comments!	440
Do You Need Technical References?	441
Problem Determination Tips	442
Phone Numbers, U.S. and Canada	443
Notices	445
Trademarks	445

Safety Information

The following section contains the safety information that you need to be familiar with before servicing a PS/2 product.

General Safety

Follow these rules to ensure general safety:

Observe good housekeeping in the area of the machines during and after maintenance.

When lifting any heavy object:

1. Ensure you can stand safely without slipping.
2. Distribute the weight of the object equally between your feet.
3. Use a slow lifting force. Never move suddenly or twist when you attempt to lift.
4. Lift by standing or by pushing up with your leg muscles; this action removes the strain from the muscles in your back. *Do not attempt to lift any objects that weigh more than 16 kg (35 lb) or objects that you think are too heavy for you.*

Do not perform any action that causes hazards to the customer, or that makes the equipment unsafe.

Before you start the machine, ensure that other service representatives and the customer's personnel are not in a hazardous position.

Place removed covers and other parts in a safe place, away from all personnel, while you are servicing the machine.

Keep your tool case away from walk areas so that other people will not trip over it.

Do not wear loose clothing that can be trapped in the moving parts of a machine. Ensure that your sleeves are fastened or rolled up above your elbows. If your hair is long, fasten it.

Insert the ends of your necktie or scarf inside clothing or fasten it with a nonconductive clip, approximately 8 centimeters (3 inches) from the end.

Do not wear jewelry, chains, metal-frame eyeglasses, or metal fasteners for your clothing.

Remember: Metal objects are excellent conductors.

Wear safety glasses when you are:

- Hammering
- Drilling
- Soldering
- Cutting wire
- Attaching springs
- Using solvents
- Working in any other conditions that might be hazardous to your eyes

After service, reinstall all safety shields, guards, labels, and ground wires. Replace any safety device that is worn or defective.

Reinstall all covers correctly before returning the machine to the customer.

Electrical Safety

Observe the following rules when working on electrical equipment:

Find the room emergency power-off (EPO) switch, disconnecting switch, or electrical outlet. If an electrical accident occurs, you can then operate the switch or unplug the power cord quickly.

Do not work alone under hazardous conditions or near equipment that has hazardous voltages.

Disconnect all power before:

- Performing a mechanical inspection
- Working near power supplies
- Removing or installing main units

Before you start to work on the machine, unplug the power cord. If you cannot unplug it, ask the customer to power-off the wall box that supplies power to the machine and to lock the wall box in the off position.

If you need to work on a machine that has *exposed* electrical circuits, observe the following precautions:

- Ensure that another person, familiar with the power-off controls, is near you.

Remember: Another person must be there to switch off the power, if necessary.

CAUTION:

Some hand tools have handles covered with a soft material that does not insulate you when working with live electrical currents.

Use only approved tools and testers.

- Use only one hand when working with powered-on electrical equipment; keep the other hand in your pocket or behind your back.

Remember: There must be a complete circuit to cause electrical shock. By observing the above rule, you may prevent a current from passing through your body.

- When using testers, set the controls correctly and use the approved probe leads and accessories for that tester.

CAUTION:

Many customers have, near their equipment, rubber floor mats that contain small conductive fibers to decrease electrostatic discharges. Do not use this type of mat to protect yourself from electrical shock.

- Stand on suitable rubber mats (obtained locally, if necessary) to insulate you from grounds such as metal floor strips and machine frames.

Observe the special safety precautions when you work with very high voltages; these instructions are in the safety sections of maintenance information. Use extreme care when measuring high voltages.

Regularly inspect and maintain your electrical hand tools for safe operational condition.

Do not use worn or broken tools and testers.

Never assume that power has been disconnected from a circuit. First, *check* that it has been powered-off.

Always look carefully for possible hazards in your work area. Examples of these hazards are moist floors, nongrounded power extension cables, power surges, and missing safety grounds.

Do not touch live electrical circuits with the reflective surface of a plastic dental mirror. The surface is conductive; such touching can cause personal injury and machine damage.

Do not service the following parts *with the power on* when they are removed from their normal operating places in a machine:

- Power supply units
- Pumps
- Blowers and fans
- Motor generators

and similar units. (This practice ensures correct grounding of the units.)

If an electrical accident occurs:

- **Use caution; do not become a victim yourself.**
- **Switch off power.**
- **Send another person to get medical aid.**

Safety Inspection Guide

The intent of this inspection guide is to assist you in identifying potentially unsafe conditions on these products. Each machine, as it was designed and built, had required safety items installed to protect users and service personnel from injury. This guide addresses only those items. However, good judgment should be used to identify potential safety hazards due to attachment of non-IBM features or options not covered by this inspection guide.

If any unsafe conditions are present, you must determine how serious the apparent hazard could be and whether you can continue without first correcting the problem.

Consider these conditions and the safety hazards they present:

- Electrical hazards, especially primary power (primary voltage on the frame can cause serious or fatal electrical shock).

- Explosive hazards, such as a damaged CRT face or bulging capacitor

- Mechanical hazards, such as loose or missing hardware

The guide consists of a series of steps presented in a checklist. Begin the checks with the power off, and the power cord disconnected.

Checklist:

1. Check exterior covers for damage (loose, broken, or sharp edges).
2. Power-off the computer. Disconnect the power cord.
3. Check the power cord for:
 - a. A third-wire ground connector in good condition. Use a meter to measure third-wire ground continuity for 0.1 ohm or less between the external ground pin and frame ground.
 - b. The power cord should be the appropriate type as specified in "Parts Catalog" on page 222.
 - c. Insulation must not be frayed or worn.
4. Remove the cover.
5. Check for any obvious non-IBM alterations. Use good judgment as to the safety of any non-IBM alterations.
6. Check inside the unit for any obvious unsafe conditions, such as metal filings, contamination, water or other liquids, or signs of fire or smoke damage.
7. Check for worn, frayed, or pinched cables.
8. Check that the power-supply cover fasteners (screws or rivets) have not been removed or tampered with.

Handling Electrostatic Discharge-Sensitive Devices

Any computer part containing transistors or integrated circuits (ICs) should be considered sensitive to electrostatic discharge (ESD). ESD damage can occur when there is a difference in charge between objects. Protect against ESD damage by equalizing the charge so that the machine, the part, the work mat, and the person handling the part are all at the same charge.

Notes:

1. Use product-specific ESD procedures when they exceed the requirements noted here.
2. Make sure that the ESD protective devices you use have been certified (ISO 9000) as fully effective.

When handling ESD-sensitive parts:

Keep the parts in protective packages until they are inserted into the product.

Avoid contact with other people.

Wear a grounded wrist strap against your skin to eliminate static on your body.

Prevent the part from touching your clothing. Most clothing is insulative and retains a charge even when you are wearing a wrist strap.

Use the black side of a grounded work mat to provide a static-free work surface. The mat is especially useful when handling ESD-sensitive devices.

Select a grounding system, such as those listed below, to provide protection that meets the specific service requirement.

Note: The use of a grounding system is desirable but not required to protect against ESD damage.

- Attach the ESD ground clip to any frame ground, ground braid, or green-wire ground.
- Use an ESD common ground or reference point when working on a double-insulated or battery-operated computer. You can use coax or connector-outside shells on these computers.
- Use the round ground-prong of the AC plug on AC-operated computers.

Grounding Requirements

Electrical grounding of the PS/2 computer is required for operator safety and correct computer function. Proper grounding of the electrical outlet can be verified by a certified electrician.

Drive and Diskette Compatibility Matrix

The following table provides identification information for 3.5-inch diskette drives.

Diskette Drive	Identifying Mark
3.5-Inch - 1.44MB	1.44 on the eject button
3.5-Inch - 2.88MB	2.88 on the eject button

The following table provides compatibility information for 3.5-inch diskettes and 3.5-inch diskette drives.

Diskette Capacity	1.44MB Drive	2.88MB Drive
1.0MB	Read/Write	Read/Write
2.0MB	Read/Write	Read/Write
4.0MB	Not Compatible	Read/Write

The following table provides identification information for 5.25-inch diskette drives.

Diskette Drive	Identifying Mark
5.25-Inch - 360KB (External)	Asterisk on bezel
5.25-Inch - 1.2MB (Internal)	1.2 on the eject button

The following table provides compatibility information for 5.25-inch diskettes and 5.25-inch diskette drives.

Diskette Capacity	360KB Drive	1.2MB Drive
360KB	Read/Write	Read/Write
1.2MB	Not Compatible	Read/Write

Notes:

1. A 360KB diskette written to or formatted on a 1.2MB drive can be read reliably only on a 1.2MB drive.
2. On some early 90 and 95 computers with a type 1 processor board installed, the system board used will not support the 2.88MB diskette drive.

Hard Disk Drive Settings (ATA)

These drives have jumper, tab, or switch settings. Always set the first drive to be the primary (master) drive 1 . If a second drive is installed, set it to be the secondary (slave) drive 2 .

Note: Do not move any *other* jumpers, tabs, or switches on the drives.

40MB and 80MB ATA Drives with Jumpers

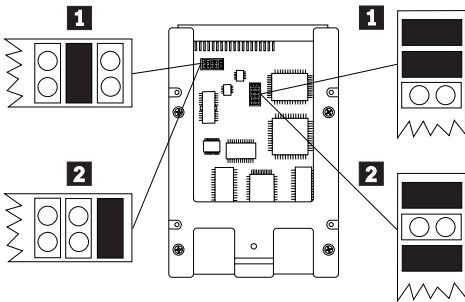

120MB ATA Drive with Jumpers

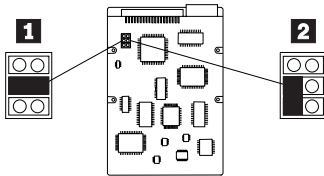

40MB ATA Drive with Switches

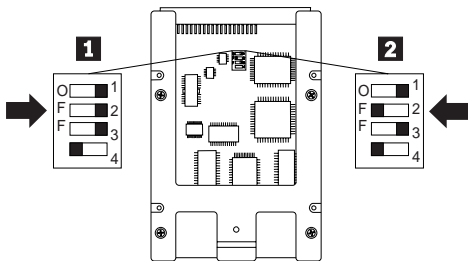

80MB and 170MB ATA Drives with Tabs

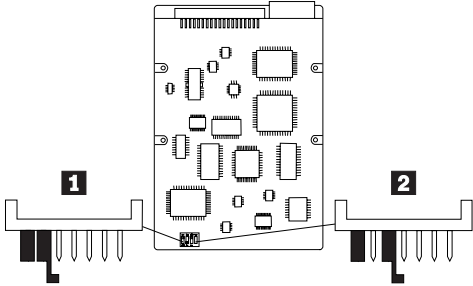

80MB ATA Drive with Switches

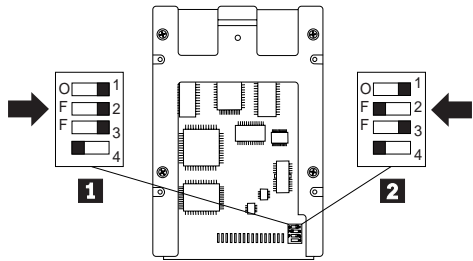

120MB ATA Drive with Jumpers

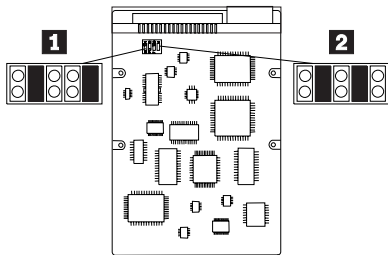

170MB, 212MB, and 245MB ATA Drives with Jumpers

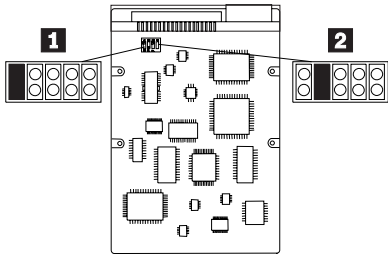

120MB, 170MB, 245MB, and 340MB ATA Drives with Tabs

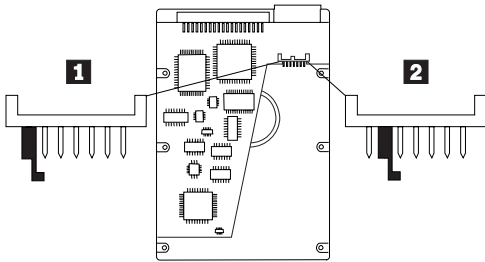

120MB, 170MB, 245MB, and 340MB ATA Drives with Tabs

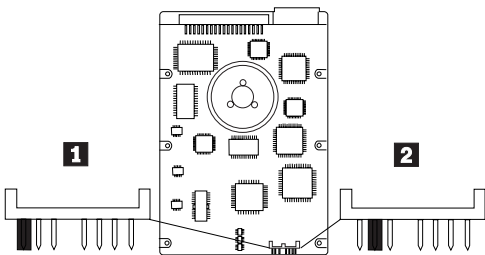

170MB, 212MB, 245MB, 340MB, and 420MB ATA Drives with Tabs

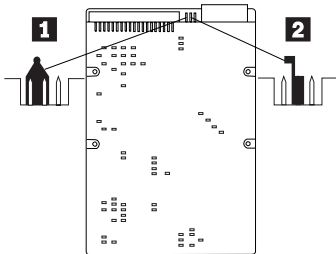

527MB ATA Drive with Jumpers

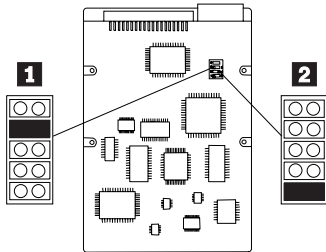

Preparing a Hard Disk for Moving

Before moving a model 25, 25 SX, 25-286, 30, 30-286, 35, 40, or 50 system unit, or removing the hard disk drive from these systems for service, select **Move the computer** from the Main Menu on the Starter Diskette or Reference Diskette. This parks the heads of the hard disk drive to help prevent damage to the drive. Head parking is automatic on all other systems.

Security

There are several security features to help protect the system, the internal hardware, and the information stored on the hard disk.

U-Bolt

Some systems have two holes at the rear of the system to allow a U-bolt to be used with a cable or chain to secure the system to a desk or table.

Cover Lock and Tamper-Evident Switches

Some systems have an electro-mechanical cover lock. In the locked position, it mechanically prevents the cover from being removed. If the covers are forced open, the tamper-evident cover switches detect the intrusion. The next time the computer is powered-on, POST displays a message informing the user that the system covers have been tampered with, and that you must run **Automatic configuration** to continue.

Notes:

1. When the cover is removed, power is removed from the computer. If you want to run the system with the cover off, you must move the security switch to the "up" or "on" position. (Move the blue slider up until it contacts the metal actuator arms of the two switches. The switches "click" when activated.) If the switches fail to activate, they must be adjusted or replaced. To adjust the switches, remove the adapter guide with the switches from the system unit. Form the actuator arms so the switches activate when the slider is moved up half the distance of its travel.
2. If you received a 000**14908** or 000**14909**, while testing the system with the front bezel installed, do the following.
 - a. Remove the side cover.
 - b. Install the front bezel.
 - c. While observing switch 1 (attached to the side of the drive support structure), operate the keylock.
 - d. If operating the keylock does not fully operate switch 1, replace the keylock assembly and switch transfer assembly located inside the front bezel.

Rear-Panel Security Option

If this option is installed on the system, it prevents cables from being removed from the back of the system, and prohibits connecting other systems or devices to unused connectors on the back of the system.

Passwords

Any combination of up to 7 alphanumeric characters (A–Z, a–z, and 0–9) is supported.

Note: If the wrong password is typed three times, the system logs an error in the system error log and you cannot continue without restarting the system.

Removing a Power-On Password: The method used to erase a power-on password varies, and so does the location of the password jumper (known as the *override* jumper.) Make sure you either backup, or make note of, the current configuration before you erase the password. After service, follow the instructions on the screen, and reset the date, time, and any customized configuration data. (You can use Backup/Restore to save it, or Automatic Configuration after service.)

To erase the power-on password, do the following:

Models 25, 30, 33, 35, 40, 56, 57, 76, 77, 85, 90, 95 Override Jumper

The override jumper is located on the system board.

System	Jumper Location
Model 25 SX	J2
Models 25, 30 (286)	J13
Models 8535, 8540	J14
Models 9533, 9535, 9540	J20
Models 8556, 8557	J18
Models 9556, 9557, 9576, 9577, 9595	JMP1
Model 90	J10
Server 85, Model 95	J16

1. Power-off the computer and unplug the power cord.
2. Remove the system-unit cover.
3. Move the password jumper to connect the center pin and the pin on the opposite end of the connector.
4. Power-on the computer. The system senses the change in the jumper position and erases the password. There is no need to move the jumper back to the previous position.

Model 55 SX, 65 SX Override Jumper

1. Power-off the computer and unplug the power cord.
2. Remove the system-unit cover.
3. Locate the speaker cable and the connector that it plugs into.
4. Unplug the speaker cable, turn it over (180°), and plug it back in.
5. Power-on the computer. The system senses the change in the connector position and erases the password. There is no need to move the connector back to the previous position.

Model 50, 60, 70, 80 Override Jumper

1. Power-off the computer and unplug the power cord.
2. Remove the system-unit cover.
3. If the speaker assembly has pins, short pins 2 and 3 together.
4. If the speaker assembly does not have pins, insert a meter lead into connector 1 and short the other end of the lead to frame ground.

With the assembly shorted, power-on the computer. This erases the power-on password. Remove the short after POST is finished.

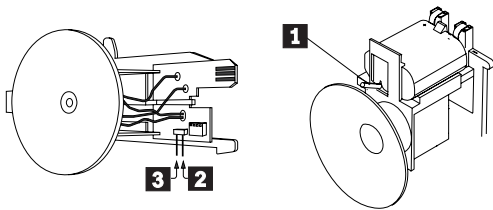

Additional Override Jumper Functions

The override jumper is most often used to erase a power-on password. However, on IML systems, moving the jumper also has the following effects on the system.

Unattended Start Mode (Server Mode)

If the Unattended Start Mode is activated, power-off the computer, move the jumper; then power-on the computer. The unattended start mode is deactivated. You must reset the Unattended Start Mode. (Power-on password is required to run in the Unattended Start Mode).

Override Jumpers on IML Systems

The Server 95A has no System Partition. It loads the IML and POST from the EEPROM on the system board or on the processor board. If a power-on password is set and the Reference Diskette is in the diskette drive, move the password override jumper; then power-on the computer. The system default is bypassed and the system loads the IML image from the Reference Diskette. The next time you power-on the computer, the IML and the POST load from the EEPROM.

The Server 85 and Server 95 load the IML from the EEPROM, but the POST is in the System Partition. If a power-on password is set and the Reference Diskette is in the diskette drive, move the password override jumper; then power-on the computer. The system default is bypassed and the system loads the IML image from the Reference Diskette. The next time you power-on the computer, the IML loads from the EEPROM and the POST loads from the System Partition.

All other IML systems system load the IML and the POST from the System Partition. If a power-on password is set and the Reference Diskette is in the diskette drive, move the password override jumper; then power-on the computer. The system default is bypassed and the system loads the IML image from the Reference Diskette. The next time you power-on the computer, the IML loads from the System Partition.

Privileged-Access Password

Note: The privileged-access password jumper is always JMP2.

This is used with other security features to make the system inoperative after a forced entry, until the password is typed. It also overrides the power-on password, if installed, and restricts access to the system programs.

You cannot erase or override the privileged-access password. The user or the technical support person at the

account should have this password. If not, the only way to gain access to the system programs is to *replace the system board at the customer's expense*.

The system is shipped with the privileged-access password feature disabled (no password is set). A jumper on the system board must be moved before a privileged-access password can be set for the first time. The jumper can either be in the *locked state* or the *change state*.

The locked state prevents a privileged-access password from being set, changed, or removed. This is the position set at the factory. The jumper is in position 1 when it is in the locked state.

The change state allows the privileged-access password to be set, changed, or removed, using the system programs. The jumper is in position 0 when it is in the change state.

The rules for setting the privileged-access password are the same as the power-on password: any alphanumeric combination of up to 7 characters (A–Z, a–z, and 0–9). One important difference is that a privileged-access password cannot be the same as the power-on password.

The privileged-access password provides several major features:

- Restricts access to the system programs.
- Stops the system after a POST error.
- Prohibits unauthorized modifications to the hardware.
- Works with the tamper-evident cover switch to prevent unauthorized operation after a forced entry.
- Can be typed at the power-on password prompt to override the power-on password.

When a privileged-access password is set, you have full use of all the features except the system programs. If you attempt to use the systems programs from the hard disk or System Diskettes, the password prompt is displayed. The correct privileged-access password must be typed before the system programs will be loaded. This prevents anyone who does not know the privileged-access password from modifying the selectable drive-startup sequence, changing the configuration information, or using any other part of the system programs.

Under normal conditions, when an error or a change in the hardware is found by POST, the system programs are loaded automatically after the error code appears. When a privileged-access password is set, the POST displays the error code, and then displays the password prompt. The system programs will not be loaded until the correct privileged-access password is typed. This prevents someone from making unauthorized modifications to the system.

Power-on Features

Some 95 server systems have power-on features. When the jumper JMP4 on the system board is enabled, the system can be turned on or off from a remote location or at a specific time.

System Features

The following are features of PS/2 systems. Refer to "PS/2 System Specifications" on page 435 to determine what is supported on the system you are servicing.

Microprocessors

The microprocessor and math coprocessor are either installed on the system board, or on a *processor board* (explained below). It interprets and carries out instructions. Microprocessor speed varies with the model. Some systems have a second connector on the system board for an optional microprocessor. An option microprocessor is installed either to enhance speed, or to add extended math capability to the system. Some systems have a jumper on the system board that allows you to change the speed of the microprocessor. Jumpers and options vary.

Processor Boards (70)

On 25-MHz model 70 systems, the microprocessor is on a small horizontally mounted card (referred to as a processor board), that plugs into the system board. This board also has a connector for a math coprocessor. For other Model 70 systems, the microprocessor and math coprocessor plug directly into a connector on the system board.

Note: The math coprocessor is a built-in feature of the microprocessor on model 70 486 and model 70s with a 486DX33 Processor Upgrade or a 486 Power Platform.

Processor Boards (90, 95)

The 90 and 95 systems have the microprocessor and other components (usually found on the system board), installed on the *processor board*. The processor board plugs into the system board just like an adapter does, except it uses a special connector (not one of the expansion slots). The system requirements, functions, and diagnostics can differ significantly depending on which *type* of processor board is installed. The major components on the processor board are:

- System microprocessor
- System clock
- Direct memory access (DMA) controller
- Memory controller

Note: Some processor boards have a built-in cache, and others have a connector for an optional plug-in cache.

The processor boards can be one of three *types* (type 1, 2 or 3). The type of processor board determines the following:

- Type of DMA controller installed (16 or 32-bit)
- Type of memory error detection supported (ECC or parity)
- Type of memory configurations supported (interleaved or noninterleaved)

The microprocessors used are 32-bit. They operate in the real-address or virtual-address (protected) mode. The amount of memory supported and the clock speed varies with the processor board. If the processor board is not seated correctly, intermittent errors can occur.

NVRAM and NVRAM Extension

Non-volatile random access memory (NVRAM) provides 64 bytes of storage. Fifty bytes are used to store system configuration and security information. The real-time clock uses the remaining 14 bytes to track the date, time, and battery level. The NVRAM extension stores additional configuration and system-status information.

The data stored in the NVRAM and NVRAM extension is kept active by the battery when the computer is powered-off. If the stored data is lost (because of a depleted or removed battery), you can restore the data by using one of the following methods:

If the user has a customized configuration that uses settings other than the default, run **Restore configuration** from the system programs.

If default configuration settings are used, run **Automatic configuration** from the system programs.

POST Overview

The power-on self-test (POST) is a series of system tests that verify the correct operation of the base system and most options. The POST runs each time the computer is powered-on. It compares the system configuration information it detects with the configuration stored in the NVRAM. The test time varies depending on the options installed. The method used to store and control the POST code varies with the system.

During power-on, POST performs basic functions such as:

- Checking the basic system-board and processor functions
- Initializing the video function
- Checking the memory subsystem
- Checking the ports

Verifying that the hard disk drive is functioning
Verifying that the code required in the System
Partition of the default hard disk is present (if System
Partition is required)
Verifying that the default diskette drive is functioning

Some adapters have ROM modules that contain extended BIOS routines that work with the system POST.

Note: FLASH systems have a feature the customer can use to automatically run a shorter, less-extensive POST routine. In this mode, POST might not detect a problem. This feature is called the *Fast Startup Mode*. You can change this setting from the Set Features screen of the system programs Main Menu.

POST and BIOS in ROM: Some systems (such as Model 50 and 60), have the POST and BIOS code contained in a read only memory (ROM) module on the system board.

POST and BIOS in IML: Some systems (such as Model 90 and 95), use Initial Machine Load (IML) to store the power-on self-test (POST) and Basic Input/Output System (BIOS) code.

In an IML system, some of this code is stored in ROM and is used for preliminary testing during power-on, but the balance of the POST and BIOS code, called the IML image, is stored in a protected area of the default hard disk called the *System Partition*. (The IML image is loaded onto the default hard disk when the system is manufactured.)

Note: On IML systems, if there is a power-on password set, the system always loads the IML image from the System Partition *even if the Reference Diskette is in the drive*. To load IML from the Reference Diskette, erase the power-on password.

POST and BIOS in FLASH: Some systems (such as Server 85, Server 95, and Server 95A), have two electronically erasable programmable read only memory (EEPROM) modules, referred to as FLASH memory.

Depending on the model, these EEPROMs are either on the processor board or on the system board. The EEPROMs contain the POST and BIOS code. These systems always load the POST and BIOS code from the FLASH EEPROMs (POST and BIOS code does not reside on the System Partition or on the Reference Diskette.) FLASH allows POST and BIOS code to be updated without replacing any hardware. This is done with an *update* diskette. This diskette copies the new code to the FLASH EEPROMs. Instructions are included with an update diskette.

Note: If the customer installs an option that requires an upgrade to the POST and BIOS information, have the customer contact their Authorized IBM Dealer or Marketing Representative, or call the IBM HelpCenter (U.S. and Puerto Rico only) at 1-800-772-2227. They will receive, free of charge, a set of upgrade diskettes for their system.

Errors during POST: POST errors are displayed as follows:

ROM and IML Systems: When POST detects a problem on ROM and IML based systems, an eight-digit error code appears.

FLASH Systems: When POST detects a problem on FLASH systems, an eight-digit error code appears followed by a short text message indicating the type of failure. (These messages are generated from the code loaded into FLASH at the time the system was manufactured.)

Notes:

1. Depending on the model, these EEPROMs are either on the processor board or on the system board. The EEPROMs contain the POST and BIOS code.
2. On FLASH systems, the system always loads the POST and BIOS code from the FLASH EEPROMS (POST and BIOS code does not reside on the System Partition or on the Reference Diskette.)
3. On FLASH systems, POST and BIOS can be updated without replacing any hardware. This is done with an *update* diskette. This diskette copies the new code to the FLASH EEPROMs. Instructions are included with an update diskette.

If the customer installs an option that requires an upgrade to the POST and BIOS information, have the customer contact their Authorized IBM Dealer or Marketing Representative, or call the IBM HelpCenter (U.S. and Puerto Rico only) at 1-800-772-2227. They will receive, free of charge, a set of upgrade diskettes for their system.

Reference and Diagnostic Diskettes

These diskettes, commonly referred to as the System Diskettes, contain the utility programs and the diagnostic programs (customer and advanced).

FLASH and IML systems also have the exact same programs stored in the System Partition. The preferred method of operation is to run the programs from the System Partition; however, if the default hard disk drive is not working, you can run the programs from the System Diskettes.

Notes:

1. The Reference Diskette contains the system programs, and the Diagnostic Diskette contains the testing programs.
2. Some earlier Model 90 and Model 95 systems used more than one type of Diagnostic Diskette depending on the type (1, 2, or 3) of processor board installed in the system. The latest release of Model 90/95 System Diskettes provides one combined Diagnostic Diskette, and separate Reference Diskettes (one for each type of processor board).
3. Server 95A is a disk array system; therefore, none of the hard disks have a System Partition. You must run diagnostics from the System Diskettes for the base system, and from the IBM RAID Controller diskette, for the disk array devices.

Accessing System Programs and Starting Diagnostic Tests

The method used to access the system programs in order to start the diagnostic tests varies with the system. After you get to the system programs Main Menu, you can run any of the utility programs or start diagnostic tests.

Starting Advanced Diagnostics on ROM Based Systems:

1. Insert the Reference Diskette into diskette drive A.
2. Power-on the computer, and follow the instructions on the screen until the System Programs Main Menu appears.
3. Press **Ctrl+A** to select the advanced diagnostic mode. The advanced diagnostics menu appears.
4. Select **System Checkout** from the advanced diagnostics menu. Follow the instructions on the screen to select your choice of tests.

Starting Advanced Diagnostics on IML Based Systems:

1. Power-on the computer and wait for the C: prompt.
2. Press **Ctrl+Alt+Del** and watch the cursor closely. When the cursor moves to the upper-right corner of the screen, press **Ctrl+Alt+Ins**. The system programs main menu appears.
3. Press **Ctrl+A** to select the advanced diagnostic mode. The advanced diagnostics menu appears.
4. Select **System Checkout** from the advanced diagnostics menu. Follow the instructions on the screen to select your choice of tests.

Note: If you are using the System Diskettes, start the Reference Diskette, and press **Ctrl+A** from the Main Menu. When you select diagnostics, you will be prompted when to insert the Diagnostic Diskette (the Diagnostic Diskette itself is not bootable.)

Starting Advanced Diagnostics on FLASH Based Systems:

1. Power-on the computer; the IBM logo screen appears.
2. Press **F1** when the **F1** prompt appears at the bottom of the screen. The System Programs main menu appears. Follow the instructions on the screen to select your choice of tests.

Starting Advanced Diagnostics on LAN Workstations

1. Have the LAN administrator make the Reference and Diagnostic programs available to you through the server.
2. Press **Ctrl+A** to select the advanced diagnostic mode. The advanced diagnostics menu appears. Follow the instructions on the screen to select your choice of tests.

Replacing Hard Disk Drives That Have a System Partition

Important

When troubleshooting a failure involving a hard disk drive with a System Partition (commonly referred to as the *default* hard disk), be aware of the following.

On IML systems, if a power-on password is set, the system always attempts to load the IML image (POST and BIOS code) from the System Partition. The only way to load IML from the Reference Diskette is to first erase the power-on password. For example, if the hard disk is dead, and a power-on password set, and then you boot the Reference Diskette, you will get an error. The system is trying to load IML from an inoperable hard disk. To avoid this, you must first erase the power-on password first. (If there is a privileged-access password set, you do not need to erase it, but you will be prompted to enter it.)

On FLASH systems, POST and BIOS code is contained in the FLASH EEPROMS. Regardless of the condition of the default hard disk, you will always be able to load diagnostics from the Reference Diskette.

On Model 90 and Model 95, be sure you have the correct type of Reference Diskette (there is more than one type).

(For a list of FLASH and IML systems, see "PS/2 System Specifications" on page 435.)

After you replace the default hard disk drive, that is, the drive with the System Partition, you must recopy all of the

system programs onto the replacement hard disk. To recopy the programs:

1. Start the system using the customer's *backup copy* of the current System Partition.
2. Select **Backup/Restore system programs** from the Main Menu.
3. Run the **Restore the System Partition** option to load the IML image (if it is an IML system), the system programs, and the customer and advanced diagnostic programs onto the default hard disk drive.

Notes:

1. If the user's backup copy of the System Partition is incomplete, you will not restore the entire System Partition. If this occurs, after you have recopied the IML image, get the option diskettes and use **Copy an option** to recopy the option files onto the System Partition.
2. If the IML image is loaded onto the hard disk, but the operating system is not loaded, either the Insert-Diskette icon, an **I9990305**, or a text message appears on the screen.

QAPIus/PRO Diagnostics

The following tools are available to help identify and resolve hardware-related problems:

- Power-on self-test (POST)
- POST Beep Codes
- Test programs
- Error messages
- Diagnostics Diskette

Power-On Self-Test (POST): Each time you power-on the system, it performs a series of tests that check the operation of the system and some options. This series of tests is called the *power-on self-test*, or *POST*. POST does the following:

- Checks some basic system-board operations
- Checks the memory operation
- Starts the video operation
- Verifies that the diskette drives are working
- Verifies that the hard disk drive is working

If the POST finishes without detecting any problems, a single beep sounds and the first screen of your operating system or application program appears.

If the POST detects a problem, an error message appears on your screen. A single problem can cause several error messages to appear. When you correct the cause of the first error message, the other error messages probably will not appear on the screen the next time you turn on the system.

POST Beep Codes: The Power On Self-Test generates a beeping sound to indicate successful completion of POST or to indicate that the tests detect an error.

One beep and the appearance of text on the display indicates successful completion of the POST. More than one beep indicates that the POST detects an error.

Test Programs

The QAPLus/PRO test programs, developed by DiagSoft** for IBM, are the primary method of testing the IBM components of the system and some external devices. The amount of time required to test all components depends on the number of components. The more optional adapters and devices you have attached to your system, the longer the testing takes.

The test programs on the Diagnostic Diskette include the following features:

Feature	Description
Advanced Diagnostic Tests	Identifies most problems associated with the following major components: <ul style="list-style-type: none"> System board Hard disk drives Diskette drives CD-ROM drives RAM Serial and parallel ports Video adapter Printer Keyboard Mouse
Flexible Test Control	Allows you to: <ul style="list-style-type: none"> Run groups of tests in batch Specify parameters to use for each test (for example, video modes, disk cylinders, port addresses, and so on) Specify the number of passes you want to run (one to continuous) Log the test results to a text dBase (DBF) format file Save all test settings for future use View System Information View the server's configuration information. (For example, you can view the IRQ/DMA assignments, memory usage, device drivers, and so on.) Select System Utilities Run a low-level format also contains system utilities. Format a diskette

** DiagSoft is a trademark of DiagSoft, Inc.

Error Messages: Messages generated by the software—the operating system or application programs—generally are text messages, but they also can be numeric. Basically, there are five types of error messages.

- POST error messages
- Diagnostic error messages
- POST beep codes
- Software generated messages.
- Multiple messages

Error Message	Description
POST Error Messages	Displayed when POST finds problems with the hardware or detects a change in the hardware configuration.
POST Beep Codes	Sounds emitted from the speaker if POST finds a problem. One beep indicates POST completed successfully. Multiple beeps indicate a problem was found by the POST.
Diagnostic Error Messages	Displayed when a test program finds a problem with a hardware option.
Software Generated Error Messages	Displayed if a problem or conflict is found by an application program, the operating system, or both. For an explanation of these messages, refer to the information supplied with that software package.
Multiple Messages	The first error that occurs can cause additional errors. Follow the suggested action of the first error displayed. In this case, the system displays more than one error message. Always follow the suggested action instructions for the <i>first</i> error message displayed.

Return Codes: For the test programs to properly determine if a test *Passed*, *Failed*, or *Aborted*, the test programs check the error-return code at test completion. To register the test properly in the test log, the test programs must generate one of the following return codes:

Return Code	Description
0	Indicates that the device passed its test.
1	Indicated that the device failed its test.
2 or greater	Indicates that the test stopped or was aborted.

Using the Test Programs

The test programs provide advanced functions and utilities for power users and service or support professionals to troubleshoot even the most difficult problems.

Program Navigation: You can maneuver within the test programs by typing the first letter of a menu choice, using the function keys, or using command-line options.

Using the First Letter of a Menu Choice

Throughout the test programs, pressing the first letter of an option on a menu is the same as moving to that item with the cursor and pressing Enter; however, this function is not enabled on Test Group Screens.

Using the Function Keys

Use the following keys to maneuver throughout the test programs:

Keys	Action
Enter	Select an item, run the test module, or run the test
Down Arrow ()	Moves the cursor down
Up Arrow ()	Moves the cursor up
F1	Calls up the appropriate Help information. Use the up arrow key () or the down arrow key () to scroll through the information. Pressing F1 from within a Help screen provides a help index from which you can select different categories. One of the important help categories is function key usage. Pressing Esc exits Help and returns to where you left off.
Esc	Go back to the previous menu

Additional functions are available in the Test Module Selection screen and the Test Group screen using the following keys:

Keys	Action
Tab	Move to test group (or move to parameters)
Spacebar	Toggle modules on/off (or toggle tests on/off)
F2	View test results log
F10	Local menu
+	Next logical unit number (for example, LUN 1, LUN 2, and so on)
-	Previous logical unit number

Command Line Options

The following Command Line Options are available when initially starting the diagnostic program from within its directory.

Type **QAPLPRO/XXX** (where **/XXX** represents one of the following from the list below) then press Enter.

Command	Action
/B&W	The /B&W command line option forces the program to load in Black and White (Monochrome) mode, which is often more readable on laptop computers.
/LOG=file	The /LOG=file command line option directs the test programs to start using a specified Error Log file.
/INT10	The /INT10 command line option forces the test programs to use the BIOS for screen writes.
/OXXX	The /OXXX command line option, where XXX=test group (for example, MBD/MEM/VID/HDU/FDU/KBD/COM/LPT, and so on), omits the designated test group from testing.
/USRCONFIG =file	The /USERCONFIG=file command line option tells the test programs to look for a user diagnostic configuration file other than the default USERDIAG.CFG.
/SCRIPT =file[,R]	The /SCRIPT=file[,R] command line option with the “,R” runs the selected script. Please see “Scripting” on page 391 for a description of scripting. Note: You can use a “-” instead of a “/” as the command line switch.

Viewing the Test Groups: As you move the cursor bar up or down in the Test Module Selection window, the right hand screen changes to show the attributes, parameters, and the selected tests of the corresponding Test Group. The diamond “ ” mark indicates a module selected for testing.

The indicated attributes are characteristics of the selected test module that are used by the test programs to determine which tests to run or how to run selected tests. Attributes are also used to limit the allowable range of parameters (for example, – ending cylinder).

Parameters are values you select to establish the scope of tests. For example, you can select Extended Memory testing parameters and limit the testing to a specific range of test blocks by specifying the starting and ending memory block. This might be appropriate if prior experience indicates that problems are likely to exist in a

specific area of memory. By selecting these limiting parameters, you reduce memory testing time.

Scripting: Scripting allows you to select specific groups of tests, testing parameters, and options. Your selection is saved for later use as a test *Script*. To set up a test script, first select all the appropriate test groups and specific tests you want to run from the Module Testing section under Diagnostics. You should also select appropriate testing parameters and options. See “Program Navigation” on page 389, for instructions to save a test script.

Changing Logical Unit Numbers: In some instances, you can have more than one logical unit number (LUN) for a particular module. LUNs represent individual devices within a test group or module. For example, you might have two diskette drives or two hard disk drives; or, you might have base, extended, shadow, and cache memory installed in the computer. This configuration might result in as many as four or five different LUNs in the Memory Test Group. Or you might have base, extended, shadow, and cache memory installed in the system which might result in as many as four or five different LUNs in the Memory Test Group.

From either the Module Test Menu or the Test Group window, you can change to a different LUN (where applicable) by pressing the plus (+) key (next LUN), or the minus (-) key (previous LUN).

Test Group Specifications: In the upper-right-hand portion of the testing screen (or just the upper portion if you switched to an individual test group screen) are the specifications for the related test group.

Note: In the Hard Disk Test Group specification area, if a software program was to compress your drive, the indicated size is the compressed size of the logical drive.

Starting the QAPLus/PRO Diagnostics Diskette

1. Insert the QAPLus/PRO Diagnostics Diskette into drive A.
2. Power-on the computer.
3. When the QAPLus/PRO Diagnostics **Main Menu** is displayed, press **Ctrl+A**.
4. Select Diagnostics; then, press **Enter**.
5. Follow the instructions that appear on your screen. If an error is displayed, go to “Symptom-to-FRU Index (QAPLus/PRO)” on page 61.

Module Testing Mode

If the test programs do not find a problem, or you want to perform in-depth testing, the Module Testing mode provides a method to run individual tests on a single module. For example, you can run an individual test for the diskette drive, or you can run groups of tests for several modules.

In the Module Testing mode, you can define how many times each test should run and how the test program should log the errors.

To start the Module Testing mode:

1. Start the diagnostics diskette. See "Starting the QAPlus/PRO Diagnostics Diskette" on page 391.
2. Select **Diagnostic** from the Main Menu.
3. Select **Module Tests** from the next menu.
4. Use the up and down arrow keys (**↑** and **↓**) to move the highlight bar from one selection to the next.
5. Follow the instructions on the screen.

Note: As you scroll down the selection menu, the Test Group window to the right changes to correspond to the highlighted Module.

Running Selected Module Tests

To run all selected tests for a test group:

1. Use the up and down arrow keys (**↑** and **↓**) to move the cursor to your selection.
2. Press **Enter**.

Note: A " " appears next to your selection.

Running All Selected Modules

To run all selected test modules:

1. Use the down arrow key (**↓**) to move the cursor to the last choice, **Run All Selected Modules**.
2. Press **Enter**.

Note: A " " appears next to your selection.

Changing Selected Tests in Test Groups

To change selected tests in a Test Group:

1. In the Module Tests Menu, use the up and down arrow keys (**↑** and **↓**) to move the cursor to your selection.
2. Press **Tab** to move into the expanded Test Group window.
3. Scroll to the test you want to select or deselect.
Warning: Items indicated by a directly adjacent "*" (red text on color screens) are destructive tests.
4. Press the spacebar at the highlighted test to toggle between select (indicated by a " ") and deselect.

Note: Pressing the first letter of a test does not activate the test, unlike menu operation.

5. Press **Enter**.

Running an Individual Test

To run an individual test:

1. Use the up and down arrow keys (**↑** and **↓**) to move to the highlighted bar to the test you want to run.
2. Press **Enter** to run the test.

Note: The results of the test appear in the lower-right-hand Test Log window. Also, if you enabled Test Logging, the results are recorded in the Test Log.

3. When the test completes, press **Esc** to return to the Test Group Menu.

Stopping the Tests: To stop running a specific test or stop testing after you have started a test, press **Esc** while the test is running. The test pauses at the first possible opportunity, and the Skip/Abort Test Menu appears with the following options:

Option	Action
Continue	The test program begins testing where it left off.
Skip to next test	The test program skips the current test, but remaining tests for the selected Test Module continue.
Skip to next group	The test program skips the remaining tests in the current test group.
Abort all tests	The test program stops and returns to the previous menu.

Using the System Utilities

The Diagnostic Diskette contains utilities for formatting diskettes, performing a low-level format on a hard disk, and editing.

Formatting Diskettes: To format a diskette within the Diagnostic programs, select one of the following options:

Format A: high density — 1.44MB

Format A: low density — 720KB

Format B: high density — 1.44MB

Format B: low density — 720KB

After selecting one of the above options to format a diskette, follow the instructions that appear on the screen.

Using the Low-Level Format Program:

Depending on the hard disk capacity, the Low-Level Format program could take up to two hours.

When To Use the Low-Level Format Program

Use the Low-Level Format program:

When you are installing software that requires a low-level format

When you get recurring messages from the test programs directing you to run the Low-Level Format program on the hard disk

As a last resort before replacing a failing hard disk drive

Preparing the Hard Disk Drive for Use:

When the Low-Level Format program is finished, restore to the hard disk all the files that you previously backed up.

1. Partition the remainder of the hard disk for your operating system. (The commands vary with the operating system. Refer to your operating-system manual for instructions.)
2. Format the hard disk using your operating system. (The commands vary with the operating system. Refer to your operating-system manual for instructions.)
3. Install the operating system.

You are now ready to restore the files.

File Editor: The File Editor is an ASCII text editor that uses simple function key commands.

To access the File Editor:

1. Select **File Editor** from the **Utility Menu**; then press **Enter**.
2. Insert a diskette into Drive A or Drive B before selecting the file you want to edit, then select the file you want to edit from the Files selection box.
3. Make your changes. The arrow keys move the cursor, and the function keys perform search and block editing functions. (See "File Edit Function Key Usage.")
4. When you are done, press **F10** to update the file with the changes you made, or press **Esc** to quit the editing process without saving the changes.

File Edit Function Key Usage: The following information describes the function of the function keys and keyboard keys when you are using the File Editor.

Key	Description
Arrows	Move the cursor to the place in the text where you want to make changes.
Home	Press Home once, to move the cursor to the start of the current line. Press Home twice, to move to the beginning of the file. Press Home three times, to move to the beginning of the file.
End	Press End once, to move the cursor to the end of the current line. Press End twice, to move the cursor to the end of the current screen. Press End three times, to move the end of the file.
F2	Press F2 , to be in search mode, You are prompted to enter the search word or words on a reverse highlighted line at the bottom of the File Edit Screen. After typing in the search word, press Enter .
F3	Press F3, to find the next occurrence of a search word.
F4	Press F4 , to mark the start of a block of text (if you have not previously marked it). If you previously marked the block of text, pressing this key unmarks the text block.
F5	Press F5, to complete the block marking (started with F4). If you did not previously press F4 to start marking a block of text, F5 is ignored.
F6	Press F6 while the cursor is within the active block to move an active (marked) block of text. Move the cursor to the new location where the active block is to be moved, then press F6 again. If there is no active block of text, F6 is ignored.
F7	To copy an active (marked) block of text to a new location, move the cursor to the new location and then press F7 . If there is no active block of text F7 is ignored.
F8	To delete an active (marked) block of text, move the cursor within the active block and press F8 . If there is no active block of text, F8 is ignored.
F10	Press F10 , to save all changes and exit the file.

Notes:

1. Always make a backup copy on a self-starting diskette of the AUTOEXEC.BAT and CONFIG.SYS files *before* making any changes.
2. The default text editing mode of the File Editor is the insert mode. To toggle between overtype and insert modes, press Insert.

QAPLus/PRO Diagnostics Control Keys: The following is a list of the QAPLus/PRO Diagnostics Control Keys, when used and a description of the diagnostics response.

Control Keys	When Used	Diagnostics Response
Ctrl+A	Main Menu	Allows you to select test from the sub menus that are highlighted with red letters. CAUTION: If selected, these test will erase the information stored on the diskette or hard disk drive.
Up and Down Arrow Keys	Main Menu Module Test Menu Test Group Menu	Highlights an item you want to select.
Space Bar	Module Test Menu Test Group Menu	Adds a diamond to the left of the highlighted test. The test will run when Run All Selected is highlighted and the Enter key is pressed. Also removes the diamond to the left of the item. The test will not run when Run All Selected is highlighted and the Enter key is pressed.
Tab Key	Main Menu Module Test Menu	Selects the additional test for the menu you are in.
+/- Keys	Test Group Menu	Selects additional test. The LUN displayed on the top right Test Group Menu shows which test is selected and how and remain (example LUN 1 of 2).

Disk Array System

The IBM PS/2 Server 95A comes with an IBM RAID Controller installed. This controller features the implementation of RAID (redundant array of inexpensive disks) technology.

In this manual, the word *array* is used to mean a collection of hard disk drives over which data is striped.

Striping is the process of storing data across all the drives that are installed in the array.

The IBM PS/2 Server 95A supports up to two different arrays. Each array (collection of physical drives) is recognized as one or more logical drives.

Before you remove and replace any SCSI devices in a Server 95A, you should be familiar with disk array features and technologies. **Warning:** If hard disk drives in the disk array are not removed and replaced correctly, data in the disk array could be lost.

To service the Server 95A, you should have the following items shipped with the system:

- Configuring Your Disk Array booklet
- Micro Channel Computers Reference
- IBM RAID Controller Diskette.

The programs on the Reference and Diagnostic Diskettes *do not* affect devices attached to the RAID controller. You only can view, manage, configure and troubleshoot devices attached to the IBM RAID Controller by using the IBM RAID Controller Diskette. Server 95A Reference and Diagnostic Diskettes

Server 95A *does not* have a System Partition on any of the hard disks; therefore, you must have a copy of these diskettes to run diagnostics on the base system.

Storage Capacity

The capacity shown and reported by the IBM RAID Controller is the binary equivalent; that is, a 540MB hard disk drive is shown on the Configuration screen as 520MB.

Data Protection

The IBM RAID Controller supports the following technology levels. The amount of data protection varies with each level.

- Level 0** Does not allow for data redundancy and any drive failure using level 0 will result in loss of data.
- Level 1** Duplicates data across all drives in the array. Because the data is duplicated, the capacity of the logical drive is reduced by 50 percent.
- Level 5** Duplicates data and parity of data across all drives in the array. The capacity of the logical drive is figured by reducing the number of disk drives by one and dividing that figure by the number of drives in the array. For example, if 3 1GB disk drives configured to 1 array and 1 logical drive, 3 minus 1 equals 2, divided by 3 (the number of drives) equals 2/3, so the

capacity of the logical drive (all the drives in the array), when configured as level 5 is 2GB.

Hot-Spare Drive

The hot-spare drive is a drive in the system that the customer has defined for automatic use in the event of a drive failure. If a drive fails, the system automatically switches to the hot-spare drive without loss of data. If the system does not have a hot-spare drive, and you replace the failed drive, the data on the failed drive is recreated from the rest of the drives in the array. This drive must be setup by the customer.

Note: When using the equations for determining the capacity of the drives for level 1 and level 5 arrays, the capacity of the hot-spare drive **is not** used.

Hot-Spare Drive Replacement

Note

It is not necessary to power-off the computer when replacing the Hot-Spare drive in a Disk Array system.

To replace the drive, do the following.

1. Remove the front bezel.
2. Insert a small coin into the slot of the small knob located on the left-hand side of the failing drive.
3. Turn the knob clockwise, one-quarter ($\frac{1}{4}$) of the way; then slide it to the left.
4. Pull the drive out of the computer.
5. Reverse this procedure to install the new drive.

Note: If the array was configured using level 0, the information on the failed drive cannot be restored to the new drive.

Bay IDs

Drives are marked with a bay ID when you insert them into a bay. If a drive is removed and reinstalled in a different bay, the system will alert you that you have a drive in an incorrect bay and tell you which bay to use.

Configuration

The IBM RAID Controller Configuration Diskette is required to configure the disk array. The Main Menu of the configuration program provides the following choices:

Help To see help for the choices on the screen.

View configuration

To see the existing disk array configuration.

Create or delete array

To select the drives for an array you want to create, or to delete a previously created array.

Initialize or synchronize array

After establishing an array.

If you are using one or more drives that have been previously used, select

Initialize logical drive to a predetermined state. Any data existing on the drive is altered.

If you do not want to alter the data on the drive, select **Synchronize logical drive** to recompute and rewrite the parity data on the drive.

Rebuild device

To replace a failed drive and rebuild logical drives (RAID levels 1 and 5).

Advanced functions

To change the way data is written to a drive. Also used to save or restore a disk array configuration to or from a diskette.

Drive information

To view information about the system's physical drives.

Exit To leave the Main Menu.

Saving Disk Array Configuration to Diskette

To back up the array configuration to diskette, do the following.

1. Insert the RAID Controller Diskette into the primary drive and press **Ctrl+Alt+Del** to start the IBM RAID Configuration Program.
2. Select **Advanced Functions** from the Main Menu.
3. Select **Save configuration to diskette.**
4. Insert a 2MB 3.5-in diskette into drive A and follow the instructions on the screen.

The file that contains the configuration is named CONFIG.DMC.

Restoring the Disk Array Configuration

To restore the disk array configuration, do the following.

1. Insert the RAID Controller Diskette into the primary drive and press **Ctrl+Alt+Del** to start the IBM RAID Configuration Program.
2. Select **Advanced Functions** from the Main Menu.
3. Select **Restore configuration from diskette;** then follow the instructions on the screen.

If the information on the backup diskette is not current, the EPROM from the failed controller can be installed on the new controller.

Recording the Vital Product Data on a New System Board

The vital product data (serial number, etc.) is stored in the EPROM on the system board. On some IBM PS/2 system boards, the vital product data (VPD) is rewritable. When replacing a system board that has rewritable VPD, the system unit serial number must be recorded on the new system board. Use the following procedure to record the system unit serial number on the new system board.

1. Power-on the computer.
2. During POST, press **F1**.
3. When the cursor moves to the lower left-hand corner, press **F1**.
4. Select item 8 **More Utilities**.
5. Select item 4 **Set System Identification**.
6. Select item 1 **Set System Identification**.
7. Type the system unit serial number in the entry field; then, press **Enter**.

The system unit serial number will be stored in the EPROM on the system board.

To verify that the serial number is properly stored in the EPROM, select **View System Configuration**.

Upgradable POST and BIOS

Server 85 and Server 95 and 95A have electronically erasable programmable read only memory (EEPROM) modules, (sometimes referred to as *Flash* memory) on the system board. These modules contain the power-on self-test (POST) routines and the Basic Input/Output System (BIOS) instructions.

The customer can upgrade the POST and BIOS code by loading a POST/BIOS Update Diskette. The customer should follow the instructions included with the diskette to copy the new information to the flash EEPROMs on the system board.

Note: If the customer installs an option that requires an upgrade to the POST and BIOS information, have the customer contact their Authorized IBM Dealer or Marketing Representative, or call the IBM HelpCenter (U.S. and Puerto Rico only) at 1-800-772-2227. They will receive, free of charge, a set of upgrade diskettes for their system.

PCMCIA Adapter (Model 33)

The (PCMCIA) adapter is an extension to the AT bus. The PCMCIA card accepts adapters about the size and shape of a credit card. These adapters, called PC Cards** have

** Trademark of the Personal Computer Memory Card International Association.

a thickness of 3.3 mm, 5.0 mm, or 10.5 mm. Available PC Cards include Ethernet, Token Ring, modems, 3270 emulator, FAX, memory, solid state hardfiles, and hard disk drives.

Two key elements of PCMCIA technology are Socket Services and Card Services. Socket Services identifies how many option slots are in the computer and detects the insertion or removal of a PC card while the computer is powered on. When a PC Card is inserted and detected, Card Services immediately reconfigures the computer to give the new PC Card access to the system memory, interrupts, and other computer functions.

Video

The video subsystem is either on the system board or the display adapter. The video subsystem operates in two video modes:

- VGA compatibility mode
- XGA compatibility mode

Most display adapters support up to 1MB of video memory. When the computer is powered-on, the graphics array is in the VGA mode. In this mode, all alphanumeric text, and the VGA all-points-addressable (APA) graphics modes are supported. The maximum resolution in VGA compatibility mode is 720 x 400 picture elements (PELS) in the text mode, and 640 x 480 PELS in the graphics mode. A maximum of 256 colors or 64 shades of gray are supported in VGA mode. Composite video is not supported.

The graphics array is in the XGA mode only when enabled by the DOS Adapter Interface or other video device drivers (example: Microsoft® Windows®, OS/2®, and Presentation Manager® device drivers).

The XGA and XGA-2 works with monochrome and color, analog, and direct-drive displays.

The following table shows how the amount of video memory available affects the maximum color and resolution.

* Trademark of the IBM Corporation.

** Trademark of the Microsoft Corporation.

Video Memory	Resolution	Colors
Four modules (512KB)	640 x 480	256
	or 1024 x 768	16
Eight modules (1MB)	640 x 480	65536
	or 1024 x 768	256

The following are examples of the refresh rates supported at the various resolutions that are available with XGA-2.

The software supplied with the XGA-2 subsystem automatically sets IBM displays at the best resolution and refresh rate possible with the hardware attached.

Resolution	Frame Rate (Hz)	Line Rate (KHz)	I/NI	IBM Display Support (Model)
640 x 480	60	31.6	NI	7544, 7554, 8503, 8504, 8507, 8512, 8513, 8514, 8515, 8516, 8517, 8518
640 x 480	72	37.9	NI	
640 x 480	72	37.8	NI	
640 x 480	75	39.4	NI	9515, 9517, 9518
800 x 600	56	35.2	NI	
800 x 600	60	37.9	NI	
800 x 600	72	48.1	NI	
800 x 600	75	50.0	NI	
1024 x 768	43.5	35.6	I	8507, 8514, 8515, 8516, 7554, 8517
1024 x 768	60	48.4	NI	
1024 x 768	70	57.0	NI	8517
1024 x 768	70	56.5	NI	
1024 x 768	72	58.1	NI	9517
1024 x 768	75	61.1	NI	9515
1280 x 1024	50	53.4	I	
Note: I= Interlaced NI = Non-Interlaced				

Non-IBM Displays

Supported resolutions (see previous table), which are not available on IBM displays, are available using some non-IBM displays. These displays range in capability from low-cost, low-function to high-cost, high function. Most of

these displays respond as an IBM 8514 display does when used with the software supplied with the XGA-2. As a result, IBM 8514 resolutions and refresh rates are used as default.

The software supplied with the XGA-2 Display Adapter/A or a computer with the IBM XGA-2 on the system board allows you to override the default screen resolution. If you do override with a resolution which does not meet, or exceeds, the capability of the display attached, unpredictable results can occur.

Warning: Some multisync displays might appear to function correctly; however, damage may occur over time.

Notes:

1. You must only select resolutions which are suitable for the display attached to the XGA-2 subsystem.
2. The use of the resolution override should be avoided if the display attached to the XGA-2 subsystem is to be changed frequently with displays of varying characteristics.

The IBM XGA-2 subsystem, along with certain IBM displays, computers, and some software, has been certified to meet the International Standards Organizations (ISO) standard 9241/3. IBM cannot guarantee that all non-IBM displays attached to the XGA-2 subsystem on the system board or an XGA-2 Display Adapter/A will provide acceptable front of screen characteristics or meet other health and safety standards.

Serial Port

Note: If you experience a problem with a non-IBM device when attaching it to either the serial port, you might need to go to the Change configuration screen of the system programs and set the port DMA (direct memory access) arbitration level to "Disabled."

The serial ports are fully programmable and support asynchronous communications. The D-shell connector provides the signals to drive a device. The connected device is identified by the system configuration as SERIAL 1 through SERIAL 8, depending on the model. Adapters with serial ports can also be configured this way. Conflicts occur with multiple communication lines if two or more lines have the same address. Select the **Set configuration** option from the system programs. Select **View configuration** to verify that no lines are addressed the same.

Note: If a conflict occurs, an asterisk appears next to the conflicting address.

Parallel Port

Note: If you experience a problem with a non-IBM device when attaching it to either the parallel port, you might need to go to the Change configuration screen of the system programs and set the port DMA (direct memory access) arbitration level to "Disabled."

The parallel ports allow the attachment of devices that accept 8 bits of parallel data at standard transistor-transistor logic (TTL) levels. The port has a D-shell connector and is designed primarily for printers. However, the port can be used as an input/output port for any device or application that matches the input/output capabilities of the port. When adapters with additional parallel ports are installed, the system supports multiple devices, each addressed separately as PARALLEL 1, PARALLEL 2, PARALLEL 3, or PARALLEL 4, depending on the model. Conflicts occur when using multiple devices if two or more devices are addressed the same. Select the **Set configuration** option from the system programs. Select **View configuration** to verify that no lines are addressed the same.

Note: If a conflict occurs, an asterisk appears next to the conflicting address.

Supported Cables

Only IBM manufactured cables in the lengths supplied by IBM are tested and supported on PS/2 systems. The performance of non-IBM and locally fabricated cables are the customer's or supplier's responsibility.

Using non-IBM cables on displays, serial, parallel, keyboard, and mouse ports might cause unpredictable problems.

Diskette-Drive Controller

The diskette-drive controller is on the system board. The controller connects to the diskette drives through a cable. Signals and voltages are supplied through the diskette-drive cable that plugs into the connector. Installing the wrong drive might cause intermittent problems.

Keyboard and Pointing-Device Connectors

The two 6-pin connectors on the rear of the system board are for a keyboard and a pointing device (mouse). The keyboard connector on most systems is marked on the back panel of the system unit with a keyboard symbol. The pointing device connector on most systems is marked with a mouse symbol.

System Memory

The following section provides information about basic memory operation. To determine the maximum memory supported on the system you are servicing, refer to "PS/2 System Specifications" on page 435.

System-Board Memory

The amount and type of system-board memory varies from model to model.

Memory-Expansion Adapters

In addition to system-board memory, many models support additional memory on memory-expansion adapters. (The only 486 system that supports memory expansion adapters is the model 70 A21.) If a memory-expansion adapter is installed in a system that does not support one, the system might work, but the memory performance will be degraded.

Memory expansion adapters can be installed in any of the expansion slots (16-bit or 32-bit depending on the model), on the system board. Memory expansion kits are installed on the memory-expansion adapters to achieve the desired memory. The amount of memory expansion kits supported varies with the option adapter. The amount of available memory can be constrained by the hardware and the operating system in use.

It is also important to understand that memory size and speed requirements are based on the requirements of the hardware that the memory module kit is plugged into. For example, a system that requires 80ns memory on the system board, might support memory adapters that require 85ns memory module kits. In that case, the memory on the adapter runs at 85ns.

The system board *does not* have to be fully populated before you add expansion memory, and each memory-expansion adapter *does not* have to be filled to capacity before you add another memory-expansion adapter.

Memory Errors

Memory errors and how the memory blocks are deallocated varies with the system. It is not necessary to understand this to service the system; however, the information is available in the model-specific *Technical Reference* manuals.

Note: On some early PS/2 systems, a memory error is not recoverable.

Unique Memory Information (90, 95)

The 90 and 95 systems share some unique memory operation.

Model 90 Memory

The figure below shows the location of the four memory-module-kit connectors J4 to J1 on the Model 90 memory-riser cards. The riser cards plug into system-board connectors J11 and J14.

The system supports up to 64MB of memory, but the amount of memory accessed might be limited by the operating system.

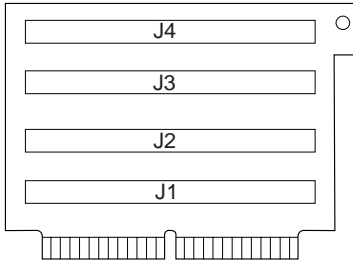

Model 95 Memory

The figure below shows the location of the memory-module-kit connectors B1 to A4 on the Model 95 system board.

The system board has eight connectors for system-board memory-module kits. The system supports up to 64MB of memory on the system board, but the amount of memory accessed might be limited by the operating system.

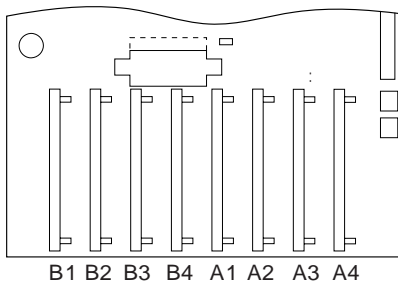

Whenever memory is added to or removed from the system, run **Automatic configuration** from the Main Menu of the system programs.

Note: If memory fails, and the customer runs diagnostics, the defective memory is disabled. When you run diagnostics, the system will indicate the amount of memory that is enabled.

After the defective memory is replaced, run the advanced diagnostic memory test to enable the *replacement* memory.

Memory Configurations (90, 95)

Interleaved configurations require matched pairs of memory-module kits. The size and the speed must be the same for both memory-module kits in the pair, but it can vary from pair to pair. The kits must be installed in the following order: pair J1 & J3 (*Model 90*) or A1 & B1 (*Model 95*), then pair J2 & J4 (*Model 90*) or A2 & B2 (*Model 95*), and so forth. This technique of addressing memory in pairs enhances performance.

Noninterleaved configurations *do not* require matched pairs of memory-module kits (the size and speed does not have to be the same). Noninterleaved memory runs less efficiently than interleaved memory, but will function with mixed sizes of memory.

Error Detection (90, 95)

The systems use *either* parity or Error Correction Code (ECC) to detect memory errors (*but not a combination of both on the same system board*).

Memory that uses *parity* can detect (but not correct) memory errors. If an error occurs during POST, an error code is displayed. If an error occurs after POST, the system halts.

Memory that uses *ECC* can detect and *correct* memory errors. If an error occurs during or after POST, the error is corrected without interfering with the system operation. This error-correcting capability will result in fewer memory-related service calls.

The memory configuration and the type of error detection supported varies depending on which processor board (type 1, 2 or 3) is installed.

Model 90 and 95 systems can be upgraded with a different type of processor board than the type indicated from the system serial and model number label. To verify which board is installed in the system you are servicing, refer to "Processor Board Matrix (90, 95)" on page 126.

Resolving Memory-Address Conflicts

The automatic configuration program might change the memory-address space used by some hardware and software options. The new address might conflict with addresses defined for use through the expanded memory specification (EMS). (EMS memory is used only in the DOS environment.)

If a memory conflict exists, one or more of the following could occur:

- The system cannot load the operating system.
- The system is disabled.
- An application does not operate or it returns an error.
- Screen messages indicate that a memory-address conflict exists.

You can resolve these conflicts in one of the following ways:

- Change the software configuration (primary method).
- Change the system configuration (alternative method).

Changing the Software Configuration

The best method of resolving memory-address conflicts is to change the software configuration by changing the addresses defined by the EMS driver.

For conflicts caused by XMA2EMS (DOS 4.0) or EMM386 (DOS 5.0) in the CONFIG.SYS file, refer to the DOS documentation. For conflicts caused by an expanded-memory manager other than the one supplied with DOS, refer to the memory manager documentation.

Note: To view the addresses used by the installed hardware and software options, go to the Main Menu, select **Set configuration** then select **Display memory map**.

Changing the System Configuration

An alternative method of resolving memory-address conflicts is to change the address of the conflicting hardware option by selecting **Change configuration** from the **Set configuration** program. Before changing adapter addresses, identify the addresses used by the EMS driver. Then set the adapter to addresses that do not conflict.

Note: These conflicts can occur because the automatic configuration program sets up only the hardware. It does not consider the operating system or application requirements. If you run automatic configuration after changing an address, the addresses you changed will be set back to their default values.

SCSI System Information

The following information pertains to systems that support SCSI devices (refer to "PS/2 System Specifications" on page 435).

SCSI Hard Disk Drives and Devices

Systems can be shipped with a Small Computer System Interface (SCSI) function. The SCSI function can be on a SCSI adapter, or built into the system board. The default hard disk drive has the IML image preloaded in a protected partition. Optional SCSI adapters can be installed in the system. Each additional SCSI adapter can support up to seven external SCSI devices.

The hard disk drives automatically position and lock the read/write heads in nondata areas when the computer is powered-off.

Understanding SCSI ID Numbers

Each SCSI device must be assigned, at the time of installation, a unique SCSI identification number (SCSI ID). The SCSI adapter or controller and the SCSI devices attached to it are referred to as a SCSI chain (the system can support more than one SCSI chain). When changing drives, be sure to see "Terminator Function" on page 414.

Selecting a SCSI ID

The SCSI ID (6, 5, 4, 3, 2, 1, or 0) available for a device depends on which IDs are already assigned to devices in the same SCSI chain. For example, if there is already one device in the SCSI chain assigned SCSI ID 6, no other SCSI devices (in that chain) can be set to SCSI ID 6.

The ID you choose determines the priority of the device. SCSI device IDs should be set as follows:

- The SCSI adapter or controller is preset as SCSI ID 7 (highest priority).

- A fixed-media read and write device, such as a hard disk drive, should be assigned a high-priority ID such as 6 or 5.

Note: The default drive with the IML code loaded is usually SCSI ID 6.

- Removable-media devices (CD-ROM, optical drive, or a tape drive), should be assigned a priority ID of 4, 3, 2, 1, or 0 (an ID below the fixed-media devices).

Typically, a low-priority or mid-priority device should not be assigned a SCSI ID higher than a high-priority device.

At the time of installation, a SCSI device should be labeled indicating the SCSI ID assigned to that device. If the *device is not labeled*, or you need to verify the SCSI ID, you can either decipher the jumper or switch settings (explained later), or you can do the following:

1. Power-on the computer and access the Main Menu of the system programs.
2. Select **Set configuration** from the Main Menu, then select **Set and view SCSI device configuration**.

The SCSI ID for each installed SCSI device is displayed on the line that begins with `Device Address`. The ID appears in a set of two numbers separated by a comma (for example: `6, 1`). The first number (in this example: `6`) is the ID assigned to the installed SCSI device.

The ID for the SCSI adapter begins with the words `SCSI Address` or `SCSI Adapter Address`.

If there are no devices connected to the SCSI controller or adapter, the screen will show only the location of the SCSI controller or adapter and the ID assigned to it.

Setting a SCSI ID

SCSI devices have either switches or jumpers to set the SCSI ID. All FRU hard disk drives are shipped preset to SCSI ID 6. The type of hardware used and the location of the jumpers or switches varies from device to device.

SCSI ID Switch Settings: To set the SCSI ID on a device that has switches, do the following:

Refer to the switches in the following figure.

Refer to the table to determine how the switches should be set for the SCSI ID you selected.

Using a ballpoint pen, set switches 1, 2, and 3 accordingly.

Switch 4 is always set to “on.”

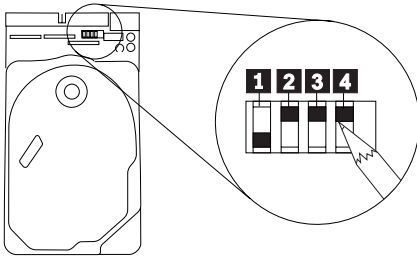

The table below shows how switches 1, 2, and 3 are set for IDs 6 through 0.

SCSI ID	Switches			
	1	2	3	4
6				
5				
4				
3				
Value	1	2	4	

SCSI ID	Switches			
	1	2	3	4
2				
1				
0				
Value	1	2	4	

Notes:

1. If present, switch 5 is always on, and switch 6 is always off.
2. On external SCSI devices that have a rotary switch to set the SCSI ID, set the switches or jumpers on the FRU device *inside the external cover* to 0 (off) to enable the rotary switch.

SCSI ID Jumper Settings: To set the SCSI ID on a hard disk drive or CD-ROM with jumpers, do the following:

Note: If you are servicing a 2GB Hard Disk Drive (SCSI) (16-bit 68-pin), refer to "2GB SCSI 16-Bit 68-Pin Hard Disk Drive ID Switch Settings."

1. Position the device so that the single pin is in the 4th position from the left. (The single pin might be in either the upper or lower position.)

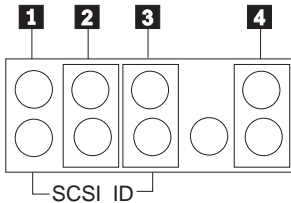

2. Refer to the table below to position the hard disk drive and CD-ROM jumpers for IDs 6 through 0.

SCSI ID	Jumpers			SCSI ID	Jumpers		
	1	2	3		1	2	3
6	:			2	:	:	
5		:		1		:	:
4	:	:		0	:	:	:
3			:				

2GB SCSI 16-Bit 68-Pin Hard Disk Drive ID

Switch Settings: To set the ID on the 2GB SCSI 16-Bit 68-Pin Hard Disk Drive do the following:

1. Position the drive as shown below.

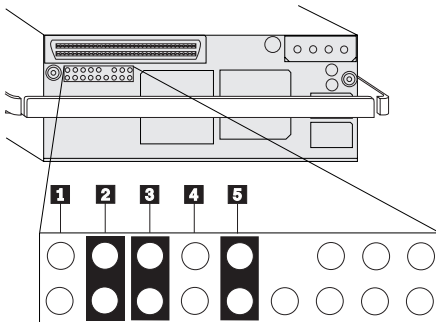

- Refer to the table below to position the hard disk drive jumpers for IDs 15 to 0.

Note: The ID selected must be supported by the system you are servicing.

SCSI ID	Setting				SCSI ID	Setting			
	1	2	3	4		1	2	3	4
7	Reserved				15				
6	:		:		14	:			
5		:	:		13	:			
4	:	:	:		12	:	:		
3		:	:		11	:			
2	:	:	:		10	:	:		
1		:	:	:	9	:		:	
0	:	:	:	:	8	:	:	:	
5 Motor Start Jumper (= on : = off)									

Optical-Head Lens Cleaning Procedure

The LED flashes when the drive is reading data. During normal operation, the LED flashes one to five times per second. A speed of less than one per second indicates a contaminated optical-head lens producing slow CD-ROM drive operation or drive failure.

To clean the optical-head lens:

- Insert the Cleaning Disk into the CD caddy.
- Insert the CD caddy into the drive.
- Allow the drive to run until the activity indicator stops flashing.
- Press and hold the eject button to remove the CD caddy.

Setting the Motor-Start Jumper

The jumper in position 5 (illustrated above) is the motor-start jumper. If the jumper is installed, all hard disk drive motors start instantly at power-on. If the jumper is removed, POST starts the drives sequentially. Some drives are shipped with the motor-start jumper installed (to reduce POST time). If many large-capacity drives are added to the computer, and they are set to start at power-on, the power supply might shut down. If this happens, it means that the total motor-start surge current of a multiple drive startup exceeds the reserve-current capacity of the power supply. You might have to *remove* one or more motor-start jumpers.

Note: Non-IBM drives use either a jumper or a switch to set the motor-start mode.

To set the SCSI ID on a Rewritable Optical Drive, do the following:

1. Position the device so that the three position jumper is at the lower-right corner.
2. Refer to the table below to position the Rewritable Optical Drive jumpers for IDs 6 through 0.

SCSI ID	Jumpers			SCSI ID	Jumpers		
	1	2	3		1	2	3
6		:		2	:	:	
5		:		1	:	:	
4		:	:	0	:	:	
3		:					

Terminator Function

Even though the system can *appear* to be operating correctly with or without terminators installed, it is *not* actually operating correctly. The SCSI Bus can operate at data rates up to 5MB per second. Because of the high speed, the bus must be terminated properly, *at both ends*, with resistors (terminators) or you eventually *will* have problems.

If you do not terminate the SCSI bus correctly, you can experience intermittent errors. For example, if a terminator is *missing*, the result might be poor signal quality or improper (higher) voltages. Intermittent errors can lead to solid failures if the SCSI devices are exposed to continuous excessive voltages.

If you have *too many* terminators installed, for example, three internal hard disk drives, each with a terminator, the result might be a drop in voltages to a point where devices will not operate, or they operate intermittently.

16-Bit AT Fast SCSI Adapter Switch Settings

- 1 Switch Location
- 2 On Position
- 3 Off Position

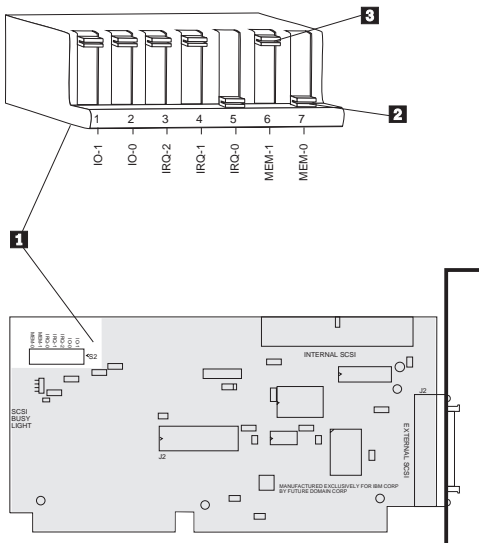

Interrupt Settings

Interrupt switches are labeled IRQ-0, IRQ-1, and IRQ-2. The default interrupt setting is IRQ-10.

IRQ-0	IRQ-1	IRQ-2	Interrupt Setting
Off	Off	Off	IRQ=3
On	Off	Off	IRQ=5
Off	On	Off	IRQ=10 (default)
On	On	Off	IRQ=11
Off	Off	On	IRQ disabled
On	Off	On	IRQ=14
Off	On	On	IRQ=15
On	On	On	IRQ disabled

Memory Address Switch Settings

Memory address switches are labeled MEM-0 and MEM-1. The default memory range is 8K from hex CA000 to CBFFF.

If you are using a memory manager, you must exclude the adapter memory address range to avoid memory conflicts. Refer to your memory manager instructions. For example,

when using the DOS memory manager EMM386, the following line in the CONFIG.SYS file excludes the adapter default memory address:

```
DEVICE=EMM386 . EXE X-CA -CBFF
```

Switch settings for memory options are listed in the following table.

MEM-0	MEM-1	Memory Setting (Hex)
Off	Off	MEM=C800
On	Off	MEM=CA00 (default)
Off	On	MEM=CE00
On	On	MEM=DE00

I/O Address

I/O address switches are labeled IO-0 and IO-1. The default I/O address range is hex 0140 to 014F.

IO-0	IO-1	I/O Address Setting (Hex)
Off	Off	IO=140 (default)
On	Off	IO=150
Off	On	IO=160
On	On	IO=170

Internal Devices Attached to an Adapter:

Internal SCSI devices attach to a SCSI adapter through a flat ribbon cable 1. The system supports multiple internal SCSI devices and uses a cable with multiple connectors. If there is only one internal SCSI hard disk drive installed, it is connected to the last connector on the cable. Because that device is the *last* device in the SCSI chain, it is the *only* internal SCSI device that requires a terminator 2.

Note: You might see a single in-line cable terminator, one or more resistor terminators (in various sizes) that unplug or slide out of the circuit board, or a pin jumper on the circuit board. All terminators are labeled T-RES. Leave any extra terminators with the system.

External Devices Attached to an Adapter:

External SCSI devices are attached through a series of cables outside the system. The first external device attaches to the SCSI adapter port through a 60-pin to 50-pin cable 3. Additional external SCSI devices link together through a 50-pin to 50-pin cable 4. The last device in the chain requires a 50-pin block terminator 5 (in the lower connector).

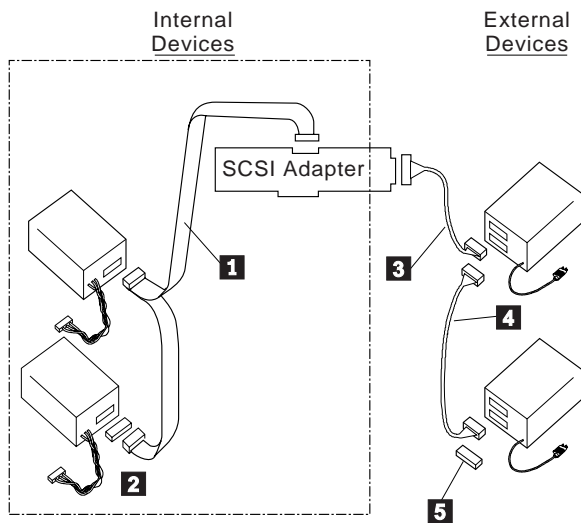

Terminators on SCSI Adapters: Termination for SCSI adapters varies, depending on which type of adapter is installed.

Note: Regardless of the SCSI adapter type used, the last external device in the chain requires a 50-pin block terminator.

Type 1 and Type 2 SCSI Adapters: The Type 1 SCSI adapter has a connector 1 (on one side) for a 20-pin terminator. Originally, only SCSI adapters without pluggable cache used the 20-pin side terminator. The newest level SCSI adapters use the 20-pin side terminator whether they have pluggable cache or not. Type 1 adapters do not require any *other* adapter terminator.

The Type 2 SCSI adapter *does not* have a terminator on the side. Instead, a 50-pin internal terminator 2 and a 60-pin external terminator 3 are used.

SCSI Device Configurations: SCSI Adapter termination varies depending on whether the SCSI devices attached are internal, external, or both.

Use the information below to determine terminator (T-RES) requirements and locations.

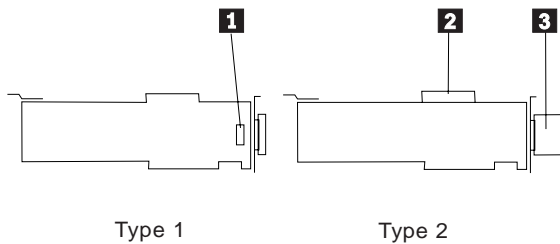

SCSI Adapter Type Used	Only Internal Devices Attached	Only External Devices Attached	Internal and External Devices Attached	T-RES Location (shown above)
1				1
1				1
1				N/A
2				3
2				2
2				N/A

Table 12. Adapter Terminator Locations

Terminators on System Boards: System boards with a built-in SCSI controller on the system board, either have removable or permanent (automatic) resistor-type terminator on the system board. The terminator is labeled T-RES.

Removable Terminators (8556, 8557)

If there is a built-in SCSI controller on the system board, and there is a removable terminator on the system board, that terminator serves the same purpose as an external terminator on a SCSI adapter. On those systems, if an external SCSI device is attached to the SCSI port on the system board, the system-board terminator must be removed. The last SCSI device *in the chain* attached to that port, requires termination.

Non-Removable Terminators (9556, 9557, 9576, 9577)

If there is a built-in SCSI controller on the system board, but there is not a removable terminator on the system board, the terminator is built into the system board. The SCSI controller termination function on these systems is automatic. For example, if there *is not* an external SCSI device connected to the system-board SCSI port, the terminator is automatically enabled. If there *is* an external SCSI device attached to the SCSI port on the system board, the terminator is automatically disabled. Because of this automatic function, you never need to install a terminator on the system-board SCSI port (even when there are no external SCSI devices attached). However, you still need a terminator on the last device in a SCSI chain (both internal and external). This is the same as on any other system with an external SCSI device attached. For example, if the system has two *internal* SCSI devices, the last one on the cable requires termination. Another example is if there are two *external* SCSI devices attached, the last device in that chain requires termination. All other SCSI devices must have the terminators removed.

Selectable Drive-Startup Function

The selectable drive-startup sequence allows the user to control the startup sequence of the drives in the system. Each time the computer is powered-on, it checks the drives as it looks for the operating system. The order which the system checks the drives is the *drive-startup sequence*.

In most cases, there is no need to change the *default* drive-startup sequence. However, if users are working with multiple hard disk drives, multiple operating systems, different size diskette drives, or they are planning to do remote initial program load (RIPL) from a drive in a network server, they might want to change the sequence.

The default sequence checks the primary diskette drive for a startable diskette. If one is present, the operating system or program is loaded from the diskette. If not, the system checks the primary hard disk for an operating system. If one is present, the operating system is loaded from that hard disk drive. If not, the system displays either the diskette and F1 prompts or the `␣990305` error code.

If the system is started from a diskette, the drive containing the diskette becomes drive A, regardless of the defined sequence. The user can choose the startup order of up to four drives, and also *customize* the startup sequence by changing the order which the system checks the drives. By making this change, the user decides which four drives are the first drives to be checked, *and* also the order which the system checks them. When the startup sequence is changed, the drive letters might also be changed. The operating system assigns the drive letters when the system starts. The assignment of the subsequent drive names will vary with the operating system or the device drivers used.

Warning: If the startup sequence is changed, you must be extremely careful when you do write operations (such as copying, saving, or formatting). The customer's data or programs can be overwritten if you select the wrong drive.

To Change the Startup Sequence: To change the startup sequence, do the following:

1. Start the system programs from the hard disk.
2. Select **Set features** from the Main Menu.
3. Select **Set startup sequence** and follow the instructions on the screen.

Example: Default Startup Sequence

The example below shows the default startup sequence for the system.

Startup Number	Device
1.....	[2.88MB 3.5-inch Diskette Drive]
2.....	[SCSI hard disk slot 1 (ID, LUN) :6,]
3.....	[Not selected]
4.....	[Not selected]

Note: The selections and device types vary.

Example: Changing the Startup Sequence

Assume the following drives are installed in the system:

Diskette Drives

- 3.5-inch diskette drive (primary)
- 3.5-inch diskette drive (second)
- 5.25-inch diskette drive (third)

Hard Disk Drives

- 400MB hard disk drive (primary hard disk drive) divided into two 200MB partitions.

If you want to start the system from a 3.5-inch diskette, a 5.25-inch diskette, or the hard disk drive, you can define the startup sequence as follows:

Startup Number	Device
1.....	[2.88MB 3.5-inch Diskette Drive]
2.....	[1.2MB 5.25-inch Diskette Drive 2]
3.....	[SCSI hard disk slot 1 (ID, LUN) :6,]
4.....	[Not selected]

In this example, the system looks for a startable diskette in the primary 3.5-inch diskette drive and *then* looks for a startable diskette in the 5.25-inch diskette drive. If there is not a startable diskette in either drive, the system loads the operating system from the System Partition on the hard disk drive.

System-Unit Power Supplies

When the computer is powered-off for 8 seconds or more and then powered-on, the power supply generates a “power good” signal that resets system logic. The presence of the “power good” signal turns on the green power-on light on the front of the system indicating that the power supply is functioning correctly.

Power-Supply Features

Most PS/2 power supplies support the following features.

Operating Voltage Range: PS/2 power supplies can be operated continuously over the following ranges: 100V Range (90 to 137 VAC) and 200V Range (180 to 265 VAC) with a sine wave input with maximum 5% total harmonic distortion.

On some models, the power supply automatically switches to the required voltage, and on others, there is a manual switch.

No-Load Operation: All PS/2 power supplies are designed to operate at No Output Load.

Over-Current Protection: All PS/2 power supplies have output over-current protection. If more than a safe current is pulled from any output on the power supply, the power supply shuts down until the on/off switch is recycled.

Short-Circuit Protection: All PS/2 power supplies have protection from shorts being placed between an output and ground, or between two outputs. This prevents damage to the power supply if a fault occurs in the system. The power supply shuts down until the on/off switch is recycled.

Over-Voltage Protection: All PS/2 power supplies have protection from output over-voltage. Before any voltage exceeds 130% of its nominal value, the power supply automatically shuts down until the on/off switch is recycled.

Under-Voltage Protection: If any voltage drops below its regulation range, the “power good” signal drops, preventing any further processing in the system.

Automatic Restart: Most PS/2 power supplies have an automatic restart feature. This allows the power supply to restart after an AC voltage power outage. Beginning with products announced in October 1990, a 3 to 6 second delay was added to enable all subsystems and peripherals ample time to reset, prior to sequencing power back to the system.

Power-Line Disturbances: All PS/2 power supplies have been tested for power-line disturbances. Power supplies will stay in specification if any of the following conditions occur:

A 20% below nominal voltage for 2 seconds repeated 10X with a 10% duty cycle (80V in 100V Range and 160V in 200V Range).

A 30% below nominal voltage for .5 seconds repeated 10X with a 10% duty cycle (70V in 100V Range and 140V in 200V Range).

A 15% above nominal voltage for 1 second repeated 10X with a 10% duty cycle (143V in 100V Range and 276V in 200V Range).

A 400Hz oscillatory, exponentially decaying disturbance at the peak of the input line voltage. The initial impulse of the disturbance will increase the input voltage by an amount equal to the nominal line voltage. This is performed 100 times at 3 second intervals.

A pulse of 1.5X the peak input voltage superimposed at the peak of the input voltage applied 100 times at 3 second intervals.

Power supplies will not be damaged if any of the following occurs:

A 100% power outage of any duration

A brownout

A 2.5kV spike is applied to the AC input (for example, a lightning strike, or a lightning simulation test).

Surge Protection: External surge suppressors are not required on PS/2 systems. The systems are designed to resist typical power surges. More severe surge levels are possible, but the probability is quite low. A defective external surge suppression device can cause intermittent system failures. No design or performance standards have been established for these devices and there is no easy way to test them. If the system has undetectable intermittent failures and there is a surge suppressor installed, try operating the system without the surge suppressor.

Safety: All PS/2 power supplies are designed to world safety requirements, such as UL, CSA, IEC, and Nordic.

Current Leakage: All PS/2 power supplies have an extremely low leakage-to-ground rating of 500 microamps. This is especially important if you are using an outlet that has a defective or missing ground line.

Reliability: PS/2 power supplies have demonstrated field failures approaching 500 000 hours before failure.

Uninterruptible Power Devices: Uninterruptible power devices are designed to supply continuous power to the system in the case of a power outage. They are usually used only when the potential loss of data or use is unacceptable.

Numerous devices of this type are available, but not all of them produce an AC sine wave voltage. U.S. PS/2 systems require sine wave. If the uninterruptible power device is defective or the wrong type, you might experience a failure that is extremely difficult to diagnose.

System Partition

This section provides information regarding the programs in the System Partition.

Notes:

1. If you are not familiar with the Reference and Diagnostic Diskettes (System Diskettes), refer to "Reference and Diagnostic Diskettes" on page 383.
2. The system diagnostics files on the Reference and Diagnostic diskettes are also on the system partition.

The System Partition is a protected area of the hard disk. It contains part of POST and BIOS (referred to as the IML image). The information stored in the System Partition is protected against accidental erasure or modification. The user cannot access the System Partition through normal operating-system Read and Write operations.

The System Partition also includes the system programs and the customer and advanced diagnostic programs. The partition is not affected when the drive is formatted using the operating system format command. The partition is *erased* if you use the advanced diagnostics format program.

Using the system programs, you can update the system programs, upgrade one version of the system partition with another version, or backup, restore, or modify the system partition.

Starting System Program Diagnostics

Start the system programs as follows:

On 9556, 9557 IML systems, power-on the computer and watch the cursor on the screen. When the cursor moves to the upper right corner, press **Ctrl+Alt+Ins** to access the system programs on the hard disk.

Note: On some systems, two tamper-evident switches are installed on the adapter guide located at the lower-left front of the system unit frame. Both switches must be in the "up" or "on" position to supply power to the computer. (Move the blue slider up until it contacts the metal actuator arms of the two switches. The switches "click" when activated.) If the switches fail to activate, they must be adjusted or replaced. To adjust the switches, remove the adapter guide with the switches from the system unit. Form the actuator arms so the switches activate when the slider is moved up half the distance of its travel.

On Server 95, Server 95A, and some Server 85 systems, power-on the computer and wait for the F1 prompt. Press **F1** to start the system programs.

On all *other IML* systems, power-on the computer and wait for the C: prompt. Press **Ctrl+Alt+Del** and watch the cursor on the screen. When the cursor moves to the upper right corner, press **Ctrl+Alt+Ins** to access the system programs on the hard disk.

On systems *without a diskette drive*, or if the IML hard disk failed, use the System Diskettes or the user's backup copy of the System Partition.

On *non-IML* systems, insert the Reference Diskette in drive A, start the system, and follow the instructions on the screen to advance to the Main Menu of the system programs.

On *LAN workstations*, access the Reference and Diagnostic Diskette image from the server.

Note: To start the Advanced Diagnostics, press **Ctrl+A** from the system programs Main Menu.

Updating the System Programs

You can update the system programs (sometimes referred to as the IML image), without writing over anything else in the System Partition. You would do this for the following reasons:

A newer version Reference Diskette was released to enhance or correct the code currently being used.

The IML image in the System Partition is corrupted, and you want to recopy it to the System Partition.

Note: If the model-specific instructions sent with an IML image update diskette vary from the instructions in this manual, use the instructions supplied with the update diskette.

1. Start the system from the Reference Diskette. Select **Update System Programs** from the Main Menu and wait for the program to complete.
2. Power-off the computer, remove the Reference Diskette.
3. Power-on the computer, check for the normal power-up sequence.

Note: If the default startup sequence was customized, be sure that the customized settings are correct after service is complete.

Upgrading the System Partition Version

Use the following instructions to upgrade the System Partition from the current version to another version.

To upgrade the version level:

1. Follow the instructions in "Backing up the System Partition" on page 427 to make a backup copy of the System Partition.

2. Using the new level Reference Diskettes, follow the instructions in "Restoring the System Partition" on page 428 to restore the System Partition.
3. Remove the diskette in drive A, power-off the system, then power-on the system. Go to the System Partition main menu.
4. Select COPY AN OPTION and follow the instructions on the screen. (When instructed to insert the Option diskette, insert the backup copy of the Reference Diskette instead.)
5. If the system you are servicing requires a two diskette set, go to the System Partition main menu again. Select COPY AN OPTION. (When instructed to insert the Option diskette, insert the backup copy of the Diagnostics Diskette instead.)
6. Go to the System Partition main menu again. Select SET CONFIGURATION.
7. Select VIEW CONFIGURATION to check that the selections shown are correct.
8. Press F3 to return to the Set Configuration menu.
9. Select BACKUP CONFIGURATION. Restart the system when backup configuration is complete.

Backing up the System Partition

Use the following instructions to make a backup copy of the System Partition.

To backup the System Partition:

1. Start the system programs. (See "Starting System Program Diagnostics" on page 425 if you need assistance.)
2. Select **Backup/Restore system programs** from the Main Menu.
3. Select **Backup the System Partition** and follow the instructions on the screen.

After making a backup, label the diskettes with the following information:

Diskette name ("Reference Diskette," and if the system has a second diskette, "Diagnostic Diskette" for the second diskette.)

Model number of the system (on the front of the system)

Type number (1, 2, or 3) of the System Programs from the Display Revision Level screen in the system programs (type 1, 2, or 3 applies to Model 90, 95 only)

Version number of the system programs (from the IBM logo screen when the system programs are started.)

In some cases, you might receive a message during the backup process informing you that the entire partition will not fit on two diskettes (this is for two diskette systems

only). This happens only if you have copied files from many option diskettes to the System Partition. The only files that might be missing from the backup diskettes are those associated with some options. If you ever need to restore the System Partition, you can do so by using the two backup diskettes (Reference and Diagnostic) with the Restore the System Partition program, then copy the option diskettes using the Copy an Option Diskette program.

Note: On the 90 and 95 systems with a Type 3 processor board installed, when you make a backup copy of the System Partition, certain files will not be loaded to the backup copy. The following files will be accessible only from the *original* Diagnostic Diskette, *not* a backup copy of the System Partition:

KP.COM
IDP.COM
DISK386.COM
RECV35.COM
UINSTALL.EXE

Restoring the System Partition

Use the following instructions to restore the System Partition to a hard disk drive that you have just replaced.

Notes:

1. This process writes over anything that is in the System Partition. Do not confuse this process with "Updating the System Programs" on page 426.
2. Use the customer's backup copy of the System Partition to restore the System Partition. If there is not a backup copy, use the Reference Diskette (some models also have a Diagnostic Diskette). You might have to recopy option files to the System Partition if they are not on the Reference Diskette.

To restore the System Partition:

1. Start the system programs. (See "Starting System Program Diagnostics" on page 425 if you need assistance.)
2. Select **Backup/Restore system programs** from the Main Menu.
3. Select **Restore the System Partition** and follow the instructions on the screen.

Be sure to reset any customized configuration or drive startup information after replacing a defective hard disk drive.

Running Automatic Configuration

Running Automatic Configuration might alter customized configuration settings. Note the current settings using **View configuration**. If the configuration was customized, save it, then restore it to the customized settings after service is complete.

Recording a Customized Configuration

If you want a copy of any customized configuration information on the System Partition, do the following:

1. If a power-on password is set, remove it before you start this procedure.
2. Power-on the computer (without a diskette in the drive).
3. Wait for the POST to finish (system beeps). Press **Ctrl+Alt+Del**. When the cursor moves to the top-right corner of the screen, press **Ctrl+Alt+Ins**.
4. Select **View configuration** and use the **Print Screen** function to print the current configuration.
5. Select **Set and View SCSI configuration** and use the **Print Screen** function to print the current SCSI configuration (SCSI device enable/disable settings).
6. If the user has changed the drive-startup sequence (or if you are not sure if it has been changed), select **Set features** from the Main Menu of the system programs. Then select **Set startup sequence** and press **Enter**.
7. An informational warning screen might appear. If so, read the information and then press **Enter**.
8. Use the **Print Screen** function to print the current selectable drive-startup sequence. Return to the Main Menu of the system programs.

You now have a copy of the following information:

- The customized configuration
- The SCSI device settings
- The selectable-drive startup sequence

⁷ Customized configuration: A system configuration that users create using the change configuration feature of the system programs. For example, the user might have changed the serial port default value, or changed a token-ring address location.

ASCII Terminals

The terminal attaches to the system board serial connector. There are physical differences among the ASCII terminals that affect the system setup.

Notes:

1. Not all systems support an ASCII terminal. (See "PS/2 System Specifications" on page 435 for more information.)
2. Not all operating systems will support an ASCII terminal.
3. Beginners All-Purpose Symbolic Instruction Code (BASIC) language is not supported when using an ASCII terminal.
4. High-resolution graphics are not available when using an ASCII terminal.

ASCII Terminal Setup and Menu Selection

Use the setup instructions supplied with the ASCII terminal. As you are using those instructions, you will need to know the following information:

Use a null-modem cable or a null-modem connector with the communication cable when attaching the ASCII terminal to the serial connector on the computer.

If the ASCII terminal has a test switch next to the keyboard connector, make sure it is in the normal position.

When you use the system programs to define the setup values on the ASCII terminal, be sure the machine mode matches the actual terminal you are installing. For example, if you are installing a 3151 ASCII Display Station, the Machine Mode on the Setup Menu must be set to IBM3151. When the setup values correctly match the terminal type, the machine is considered to be in the *native machine mode*.

Set the Communication values on the terminal as follows:

Line Speed (bps)	96
Word Length (bits)	8
Parity	No
Stop Bit	1

Notes:

1. When using the system programs, do not install an emulation cartridge unless it will support native machine mode.
2. The terminals designed for countries where English is not the native language must support the ISO 8859/1.2 code page. Some of the terminals require a cartridge to support this code page. Check the documentation supplied with the terminal to see if the terminal requires a cartridge.

ASCII Terminal Configuration

When using an ASCII terminal, you must define the setup values so that the terminal can correctly communicate with the system.

Console Selection: The system has a Set Console utility program that lets you tell the system you are using an ASCII terminal.

Without the Set Console utility program, the system will use the default values shown. The ASCII terminal values must match these values. Complete the following steps to use an ASCII terminal.

Before you make these selections in the Set Console utility program, make sure that you have an ASCII terminal *attached* to the system.

1. Start the system programs.

Note: If you start the system programs from an ASCII terminal, power-on the terminal then the system. Press and hold **Ctrl**. Then press and release **C+A+D**. When the cursor moves to the top-right corner of the screen, press **Ctrl+I**.

2. Select **Set features** on the system programs Main Menu.
3. Select **Set console** on the Set Features Menu.
4. Select **ASCII terminal** on the Set Console Menu.

The values must be:

Baud rate	96
Bits per character	8
Parity	None
Stop bits	1

Note: These instructions assume that you have already set the terminal to the same values described in "ASCII Terminal Setup and Menu Selection" on page 430.

Any time you change the ASCII terminal values, you also must update the system values to match it. The baud rate should always be 9600 or above. If you set the baud rate below 9600, system performance will be slow.

Operation: Some of the ASCII terminal operations are listed below.

Communication When using an ASCII terminal, the communication parameters will appear on the information panel (for example 96-8N1). This information is not an error message.

Configuration When you run the system programs or diagnostic programs from the ASCII terminal, the terminal values might change. Check the terminal values. If they have changed, reset them.

Utilities To start the system programs when using an ASCII terminal, follow the instructions supplied with the operating system. When the cursor moves to the top-right corner of the screen, press **Ctrl+I**.

Diagnostics When an ASCII terminal is selected as the system console, the following will not appear on the diagnostic installed device list:

- Keyboard
- Mouse
- System board async port
- Video displays

Error Messages: If you get a 161 or 173 error during POST, the selection you made in the Set Console utility program is no longer valid. When this happens, the system will look for a video adapter. If it finds one, the keyboard and display will be used as a console. If it does not find one, the ASCII terminal will be used as a console.

96 8N1 Error Message: This is not an error message. An 96 8N1 message on the Model 95 console indicates that the system is set to ASCII terminal mode. If no ASCII terminal is attached, remove the battery, then wait five minutes. Replace the battery and restart the system.

System Error Log

Note: Not all 90 and 95 systems support the system error log.

On these systems, the BIOS nonmaskable interrupt (NMI) handler writes an entry to the error log each time an error is detected.

Note: If the system halts during POST, nothing will be logged.

Viewing the Error Log

To view the error log, start the system programs and select **More utilities** from the Main Menu, then select **Display system error log**. For any error that is displayed, help screens guide you through the actions to take.

Types of Errors Detected

The error log can contain many different types of hardware or application-program related errors. The most probable cause of the failure is always indicated on the help screen. Listed below are some common errors and causes that might be displayed.

Application Program Errors

- Watchdog timeout
- DMA programming (some models)

Processor Errors

- System parity
- Cache
- Voltage (on processor boards)
- Processor board was changed (90, 95)

System Memory Errors

- Parity memory
- ECC memory (multi-bit) (90,95 Type 3 processor boards)
- ECC memory (single-bit trigger level) (90,95 Type 3 processor boards)
- POST-detected memory

Micro Channel Adapter Errors

- I/O Channel check
- DMA timeout

On DMA timeout errors, note the arbitration level displayed on the screen. Go to the "View configuration" screen and see which device has that same arbitration level. Suspect *that* device is defective.

Error Storage

The error log stores up to three *unique* errors (for example three parity errors at three different addresses). The multiple log counter (on the screen) displays the number of additional times each unique error occurred. You can page forward or backward to view the stored error logs. The date and time of the most recent occurrence also is displayed. If POST finds that the error log has stored three unique errors, POST displays a 00017900 error.

Note: If the system configuration is changed, the system clears any logged errors associated with the hardware that is changed. (For example, if the memory configuration was changed, memory errors are cleared from the error log). The conditions under which errors are automatically cleared vary with the type of hardware and the level of microcode installed.

Application

If the system does not display a POST error, (or if diagnostics run error-free) but you still suspect a problem, look at the error log. If errors are detected, they are displayed. Press the help key and follow the instructions on the screen to help you determine what might be causing the failure.

Dumping Extended Diagnostic Data Information

In cases where the system appears to have an undetectable intermittent failure, analyzing the extended data information will help find the cause of the failure. The support center might request that you dump this information onto a diskette. Dump only the extended data by request of the support center. To dump the extended data, do the following:

1. Format a scratch 2MB diskette.
2. Restart the system from the Reference Diskette (*do not* start from the System Partition or you will copy the data to the System Partition).
3. From the Main Menu, select **Set Configuration** and choose **Change configuration**.
4. Remove the Reference Diskette from the drive.
5. Insert the scratch 2MB diskette into the primary diskette drive.
6. Press F10 (this starts the bit-dump and writes two files onto the diskette).
7. After the screen message indicates that the process is complete, remove the diskette from the drive and insert the Reference Diskette.
8. Send the diskette to the support center that requested it.

PS/2 System Specifications

The following tables contain the specifications for each PS/2 model. The first table contains AT bus systems. The second table contains Micro Channel Non-IML systems. The third table contains Micro Channel IML systems.

(S/B = Slots/Bays SS = Selectable Startup)

PS/2 - AT Bus

Type	Processor	Video	S/B	Memory	SS	Hrd Dsk
8525-001,4	8086-8	MCGA	2/2	512K/640K	N	None
8525-GXX	8086-8	MCGA	2/2	512K/640K	N	None
8525-LXX	8086-8	MCGA	2/2	640K/640K	N	None
8525-286,X0X	80286-10	VGA	2/2	1M/4M	N	None
8525-286,X3X	80286-10	VGA	2/2	1M/4M	N	30M
8530-001	8086-8	MCGA	3/2	640K 640K	N	None
8530-002	8086-8	MCGA	3/2	640K/640K	N	None
8530-021	8086-8	MCGA	3/2	640K/640K	N	20M
8530-286,E01	80286-10	VGA	3/2	1M/4M	N	None
8530-286,E21	80286-10	VGA	3/2	1M/4M	N	20M
8530-286,E31	80286-10	VGA	3/2	1M/4M	N	30M
8530-286,E41	80286-10	VGA	3/2	1M/4M	N	45M
8535SX-040	386SX-20	VGA	3/2	2M/16M	Y	None
8535SX-043	386SX-20	VGA	3/2	2M/16M	Y	40M
8535LS-24X	386SX-20	VGA	3/2	2M/16M	Y	None
8535LS-14X	386SX-20	VGA	3/2	2M/16M	Y	None
8540SX-040	386SX-20	VGA	5/4	2M/16M	Y	None
8540SX-043	386SX-20	VGA	5/4	2M/16M	Y	40M
8540SX-045	386SX-20	VGA	5/4	2M/16M	Y	80M
8555-041	386SX-16	VGA	3/2	4M/8M	N	40M
8555-061	386SX-16	VGA	3/2	2M/8M	N	60M
8555-081	386SX-16	VGA	3/2	4M/8M	N	80M
8555-LT0	386SX-16	VGA	3/2	4M/8M	N	M/less
8555-LE0	386SX-16	VGA	3/2	4M/8M	N	M/less
9533-DB7	486SLC2-25/50	XGA2	4/2	8M/16M	N	120M
9533-GB7	486SLC2-25/50	XGA2	4/2	8M/16M	N	120M
9533-GBX	486SLC2-25/50	XGA2	4/2	8M/16M	N	M/less
9533-1BX	486SLC2-25/50	XGA2	4/2	8M/16M	N	M/less
9533-2BX	486SLC2-25/50	XGA2	4/2	8M/16M	N	M/less

PS/2 - Micro Channel (Non IML)

Type	Processor	Video	S/B	Memory	SS	Hrd Dsk
8550-021	80286-10	VGA	3/3	1M/1M	N	20M
8550-031	80286-10	VGA	3/3	1M/2M	N	30M
8550-061	80286-10	VGA	3/3	1M/2M	N	60M
8555-031	386SX-16	VGA	3/2	2M/8M	N	30M
8556-14X	386SX-20	VGA	3/2	4M/16M	Y	M/less
8556-24X	386SX-20	VGA	3/2	4M/16M	Y	M/less
8556-043	386SX-20	VGA	3/2	4M/16M	Y	40M SCSI
8556-045	386SX-20	VGA	3/2	4M/16M	Y	80M SCSI
8556-055	386SLC-20	VGA	3/2	4M/16M	Y	80M SCSI
8556-059	386SLC-20	VGA	3/2	4M/16M	Y	160M SCSI
8557-045	386SX-20	VGA	5/4	4M/16M	Y	80M SCSI
8557-049	386SX-20	VGA	5/4	8M/16M	Y	160M SCSI
8557-055	386SLC-20	VGA	5/4	4M/16M	Y	80M SCSI
8557-059	386SLC-20	VGA	5/4	4M/16M	Y	160M SCSI
8557-05F	386SLC-20	VGA	5/4	8M/16M	Y	400M SCSI
M57-255	386SLC-20	VGA	5/4	4M/16M	Y	80M SCSI
8560-041	80286-10	VGA	8/4	1M/1M	N	44M
8560-071	80286-10	VGA	8/4	1M/1M	N	70M
8565-061	386SX-16	VGA	8/6	2M/8M	N	60M SCSI
8565-121	386SX-16	VGA	8/6	2M/8M	N	120M SCSI
8565-321	386SX-16	VGA	8/6	2M/8M	N	320M SCSI
8570-E61	80386-16	VGA	3/3	2M/6M	N	60M
8570-061	80386-20	VGA	3/3	2M/6M	N	60M
8570-081	80386-20	VGA	3/3	2M/6M	N	80M
8570-121	80386-20	VGA	3/3	2M/6M	N	120M
8570-161	80386-20	VGA	3/3	2M/6M	N	160M
8570-A61	80386-25	VGA	3/3	2M/8M	N	60M
8570-A16	80386-25	VGA	3/3	2M/8M	N	160M
8570-A81	80386-25	VGA	3/3	2M/8M	N	80M
8570-A21	80386-25	VGA	3/3	2M/8M	N	120M
8570-B61	80486-25	VGA	3/3	2M/8M	N	60M
8570-B21	80486-25	VGA	3/3	2M/8M	N	120M
8570-B81	80486-25	VGA	3/3	2M/8M	N	80M
8570-B16	80486-25	VGA	3/3	2M/8M	N	160M
8580-041	80386-16	VGA	8/4	1M/2M	N	44M
8580-071	80386-16	VGA	8/4	2M/2M	N	70M
8580-111	80386-20	VGA	8/4	2M/4M	N	115M
8580-311	80386-20	VGA	8/4	2M/4M	N	314M
S/N below 23B3000:						
8580-081	80386-20	VGA	8/6	2M/4M	N	80M SCSI
S/N above 23B3000:						
8580-081	80386-20	VGA	8/6	4M/4M	N	80M SCSI
8580-121	80386-20	VGA	8/6	2M/4M	N	120M SCSI
S/N below 23VN700:						
8580-161	80386-20	VGA	8/6	2M/4M	N	160M SCSI
S/N above 23VN700:						
8580-121	80386-20	VGA	8/6	4M/4M	N	160M SCSI
S/N below 9225000:						
8580-321	80386-20	VGA	8/6	2M/4M	N	320M SCSI
S/N above 9225000:						
8580-321	80386-20	VGA	8/6	4M/4M	N	320M SCSI
8580-A21	80386-25	VGA	8/6	4M/8M	N	120M SCSI
8580-A16	80386-25	VGA	8/6	4M/8M	N	160M SCSI
8580-A31	80386-25	VGA	8/6	4M/8M	N	320M SCSI

PS/2 - Micro Channel (IML)

Type	Processor	Video	S/B	Memory	SS	Hrd Dsk
8590-0G5	486SX-20	XGA	4/4	4M/64M	Y	80M SCSI
8590-0G9	486SX-20	XGA	4/4	4M/64M	Y	160M SCSI
8590-0GF	486SX-20	XGA	4/4	4M/64M	Y	400M SCSI
8590-0H5	486SX-25	XGA	4/4	4M/64M	Y	80M SCSI
8590-0H9	486SX-25	XGA	4/4	4M/64M	Y	160M SCSI
S/N 23TXD00 to XPV99:						
8590-0J5	80486-25	XGA	4/4	4M/64M	Y	80M SCSI
All other S/N:						
8590-0J5	80486-25	XGA	4/4	8M/64M	Y	80M SCSI
S/N 23PAAA0 to RLTG9:						
8590-0J9	80486-25	XGA	4/4	4M/64M	Y	160M SCSI
All other S/N:						
8590-0J9	80486-25	XGA	4/4	8M/64M	Y	160M SCSI
8590-0JF	80486-25	XGA	4/4	8M/64M	Y	400M SCSI
S/N 23RLTH0 to TYKP9:						
8590-0KD	80486-33	XGA	4/4	4M/64M	Y	320M SCSI
All other S/N:						
8590-0KD	80486-33	XGA	4/4	8M/64M	Y	320M SCSI
8590-0KF	80486-33	XGA	4/4	8M/64M	Y	400M SCSI
8590-0L9	486-25/50	XGA	4/4	8M/64M	Y	160M SCSI
8590-0LF	486-25/50	XGA	4/4	8M/64M	Y	400M SCSI
8595-0G9	486SX-20	XGA	8/7	4M/64M	Y	160M SCSI
8595-0GF	486SX-20	XGA	8/7	4M/64M	Y	400M SCSI
8595-0H9	486SX-25	XGA	8/7	8M/64M	Y	160M SCSI
8595-0HF	486SX-25	XGA	8/7	8M/64M	Y	400M SCSI
S/N 23FPMZ to GMBWY:						
8595-0J9	80486-25	XGA	8/7	4M/64M	Y	160M SCSI
All other S/N:						
8595-0J9	80486-25	XGA	8/7	8M/64M	Y	160M SCSI
8595-0JF	80486-25	XGA	8/7	8M/64M	Y	400M SCSI
8595-0KD	80486-33	XGA	8/7	8M/64M	Y	320M SCSI
8595-0L9	486-25/50	XGA	8/7	8M/64M	Y	160M SCSI
8595-0LF	486-25/50	XGA	8/7	8M/64M	Y	400M SCSI
8595-0MF	486-50	XGA	8/7	16M/64M	Y	400M SCSI
8595-0MT	486-50	XGA	8/7	16M/64M	Y	1GB SCSI
9553-1BX	486SLC2-25/50	SVGA	3/3	4M/16MB	Y	Ethnetnet
9553-2BX	486SLC2-25/50	SVGA	3/3	4M/16MB	Y	Token-Ring
9553-OB7	486SLC2-25/50	SVGA	3/3	4M/16MB	Y	120MB
9553-OB8	486SLC2-25/50	SVGA	3/3	4M/16MB	Y	250MB
9556-0B6	486SLC2-25/50	XGA	3/3	8M/16M	Y	104M SCSI
9556-0BA	486SLC2-25/50	XGA	3/3	8M/16M	Y	212M SCSI
9557-0B6	486SLC2-25/50	XGA	5/4	8M/16M	Y	104M SCSI
9557-0BA	486SLC2-25/50	XGA	5/4	8M/16M	Y	212M SCSI
9557-1BA	486SLC2-25/50	XGA	4/4	8M/16M	Y	212M SCSI
9576-0H6	486SX-25	XGA2	3/3	8M/32M	Y	104M SCSI
9576-0U6	486SX-33	XGA2	3/3	8M/32M	Y	104M SCSI
9576-0UA	486SX-33	XGA2	3/3	8M/32M	Y	212M SCSI
9577-0UA	486SX-33	XGA2	5/4	8M/32M	Y	212M SCSI
9577-0UF	486SX-33	XGA2	5/4	8M/32M	Y	400M SCSI
9577-1UA	486SX-33	XGA2	5/4	8M/32M	Y	212M SCSI
9577-0NA	486DX2-33/66	XGA2	5/4	8M/32M	Y	212M SCSI
9577-0NF	486DX2-33/66	XGA2	5/4	8M/32M	Y	400M SCSI
9577-1NA	486-33/66	XGA2	4/4	8M/32M	Y	212M SCSI
9585-OKG	486DX-33	SVGA	8/7	8M/256M	Y	540MB SCSI
9585-OKT	486DX-33	SVGA	8/7	8M/256M	Y	1G SCSI
9585-ONG	486DX-33/66	SVGA	8/7	8M/256M	Y	540MB SCSI
9585-ONT	486DX-33/66	SVGA	8/7	8M/256M	Y	1G SCSI
9585-0X6	486SX-33	SVGA	8/7	8M/64M	Y	104M SCSI
9585-0XA	486SX-33	SVGA	8/7	8M/64M	Y	212M SCSI
9585-0XF	486SX-33	SVGA	8/7	8M/64M	Y	400M SCSI
9595-0LF	486-25/50	XGA2	8/7	8M/64M	Y	400M SCSI
9595-0MF	486-50	XGA2	8/7	16M/64M	Y	400M SCSI
9595-0MT	486-50	XGA2	8/7	16M/64M	Y	1GB SCSI
9595-PQG	Pentium (66MHz)	MGA	8X7	16M/256M (ECC)	Y	540MB SCSI
9595-PQT	Pentium (66MHz)	MGA	8X7	16M/256M (ECC)	Y	1GB SCSI

Acronyms, Abbreviations, and Terms

Term	Information
ACPA/A	Audio Capture and Playback Adapter
ADP	Automatic Data Processing
Alt	Alternate
ANSI	American National Standards Institute
ARTIC	A Real Time Interface Coprocessor
ASCII	American National Standard Code for Interface Interchange
AT	Advanced Technology (as in AT Bus)
ATA	AT Attached (as in AT Bus)
AVC	Audio Video Connection
BIOS	Basic Input/Output System (Controls System Resources)
bps	Bits Per Second
BPS	Bytes Per Second
CCITT	The International Telephone and Telegraph Consultative Committee
CCS	Common Command Set
CCSB	Common Complete Status Block
CD	Compact Disc
CD-ROM	CD Read Only Memory (stores data/audio)
CE	Customer Engineer or Service Representative
CRC	Cyclic Redundancy Check
CRT	Cathode Ray Tube
CSD	Corrective Service Diskette
CGA	Color Graphics Adapter (See EGA, VGA, XGA)
CCSB	Configuration Control Sub Board)
CRC	Cyclic Redundancy Check
CRT	Cathode Ray Tube
CSA	Canadian Standards Association
CSD	Corrective Service Diskette
DASD	Direct Access Storage Device (hard disk, diskette)
DMA	Direct Memory Access
DRAM	Dynamic Random Access Memory
ECA	Engineering Change Announcement
ECC	Error Correction Code
EGA	Enhanced Graphics Adapter
ESD	Electrostatic Discharge
ESDI	Enhanced Small Device Interface
EEPROM	Electrically Erasable Programmable Read Only Memory
EWS	Energy Work Station
FRU	Field Replaceable Unit (replaceable part)
GPIB	General Purpose Interface Bus (IEEE 348)
GSA	General Services Administration
HMM	Hardware Maintenance Manual
HMR	Hardware Maintenance Reference
HMS	Hardware Maintenance Service
Ht	Height
IDE	Integrated Drive Electronics
IC	Integrated Circuit
IEEE	Institute of Electrical and Electronics Engineers
IEC	International Electrotechnical Commission
IML	Initial Machine Load
IPL	Initial Program Load
ISO	International Organization for Standardization
ISDN	Integrated-Services Digital Network
LAN	Local Area Network
LBA	Local Block Address

Term	Information
LTB	Local Transfer Bus
LUN	Logical Unit Number (as in SCSI)
MAP	Maintenance Analysis Procedure
MCGA	Modified Color Graphics Adapter (320 x 200 x 256)
MCA	Micro Channel Architecture (bus structure)
MHz	Mega hertz (millions of cycles per second)
MIDI	Musical Instrument Digital Interface
MM	Multimedia
N/A	Not Available or Not Applicable
NDD	National Distribution Division
NMI	Non-Maskable Interrupt
NSC	National Support Center
NVRAM	Non Volatile Random Access Memory
OEM	Original Equipment Manufacturer
PCMCIA	Personal Computer Memory Card International Association
POS	Programmable Option Select
PUN	Physical Unit Number (as in SCSI)
RAID	Redundant Array of Inexpensive Disks (disk array models)
RAM	Random Access Memory (read/write)
RGB	Red Green Blue (as in monitors)
RIPPL	Remote Initial Program Load
ROM	Read Only Memory
SASD	Sequential Access Storage Device (Tape)
SCB	Subsystem Control Block
SRAM	Static Random Access Memory
SCSI	Small Computer Systems Interface
SCSI ID	SCSI Identification Number (assigned device number)
SPD	Software Product Description
SR	Service Representative
T/A	NDD Technical Advisor (See your Marketing Representative)
TDD	Telecommunications Device for the Deaf
UL	Underwriters Laboratory
VCA	Video Capture Adapter
VESA	Video Electronics Standards Association
VGA	Video Graphics Array (640x480x16)
VPD	Vital Product Data
VRAM	Video Random Access Memory
WORM	Write Once, Read Many Media
XGA	Extended Graphics Array (1024 x 768 x 256)
Y/C	Luminance/Chrominance Signal (Pertains to Video)

We Want Your Comments!

We want to know your opinion about this manual (part number 83G8990). Your input will help us to improve our publications.

Please photocopy this survey, complete it, and then fax it to **IBM HMM Survey at 407-982-9825 (USA)**.

Name _____

Phone Number _____

1. Do you like this manual?

Yes No

2. What would you like to see added, changed, or deleted in this manual?

3. What is your service experience level?

Novice Average Advanced

4. Which PS/2 systems do you service most?

Thanks in advance for your response!

Do You Need Technical References?

We have a wide range of hardware technical references that provide in-depth information about IBM personal computer products. Our Technical Reference Library includes information about:

- Micro Channel, Setup, and Subsystem Control Block architectures

- Common interfaces (including microprocessors, system timers, parallel and serial port controllers, keyboards and keystrokes, SCSI, DMA, video, and more)

- Specific Personal System/2 systems (including system board connectors, jumpers, memory subsystems, I/O subsystems, programming interfaces and registers, and error codes)

- Basic input/output system (BIOS)

- Options and adapters

For a free catalog of our current offerings, please photocopy this form, complete it, and then fax it to **Hardware Technical References at 407-982-9825 (USA)**.

I'd like a catalog of the IBM PC Company Hardware Technical Reference library.

Name _____

Address _____

City _____

State _____ Zip _____

Problem Determination Tips

Due to the variety of hardware and software combinations that can be encountered, use the following information to assist you in problem determination. If possible, have this information available when requesting assistance from Service Support and Engineering functions.

Machine type and model

Failure symptom

- What, when, where, single, or multiple systems?
- Is the failure repeatable?
- Has this configuration ever worked?
- If it has been working, what changes were made prior to it failing?

Reference Diskette Version

- Type and revision level

Hardware configuration

- Print out (print screen) configuration from system partition or Reference Diskette currently being used.

Operating system software

- Type and revision level
- OS/2 SYSLEVEL Command

Software setup (appropriate to the software)

CONFIG.SYS

STARTUP.CMD

AUTOEXEC.BAT

Important

To eliminate confusion, identical systems are considered *identical* only if they:

1. Are the exact machine type and models
2. Have the same adapters/attachments in the same locations
3. Have the same address jumpers/terminators/cabling
4. Have the same software versions and levels
5. Have the same Partition/Reference Diskette (version)
6. Have the same configuration options set in the system
7. Have the same setup for the operation system control files (Config.Sys, Autoexec.bat, Startup.Cmd., etc.)

Comparing the configuration and software set-up (Config.sys, etc.) between "working and non-working" systems will often lead to problem resolution.

Phone Numbers, U.S. and Canada

Before you place a call to the Support Center, refer to "Problem Determination Tips" on page 442.

U.S. Authorized Dealers or Servicers

Number	Information
1-800-937-3737	IBM Business Partner Education
1-800-426-2472	IBM Customer Engineer Technical Support
1-800-426-7763	IBM National Support Center
1-800-IBM-DEAL	IBM PartnerLink Technical Support
1-303-924-4015	IBM Part Number ID and look up
1-800-237-5511	IBM Software Defect Support (CSDs)
1-800-327-5711	IBM Software Ordering (service publications)
1-800-426-1484	IBM Supplies Technical Hotline
1-800-759-7483	IBM Warranty Claims Center
1-800-342-6672	OS/2 Replacement Diskettes (problems during new system installation)

U.S. Customers and Helpware Subscribers

Number	Information
1-800-426-8322	Customer Education Business Unit
1-800-999-0052	Customized Operational Services
1-407-982-6408	Developers Assistance (HW & SW)
1-800-964-8523	End User Support
1-800-772-2227	HelpCenter*
	HelpLearn*
	Customer Satisfaction Center
1-800-426-4238	HelpCenter* (TDD/ASCII)
1-800-742-2493	IBM Anti-Virus Services
1-800-447-4700	IBM Authorized Dealer Referrals
1-404-835-6600	IBM Bulletin Board
1-800-426-4238	IBM Customer Satisfaction Center (TDD/ASCII)
1-800-426-2468	IBM Dealer Referral (typewriters/printers)
1-800-426-2468	IBM Direct (supplies, education)
1-800-282-0226	IBM Field Television Network
1-800-426-3333	IBM Information Referral Service
1-800-IBM-SERV	IBM Service
1-800-426-7282	IBM Technical Manuals
1-800-426-9402 (Ext. 150)	Multimedia Information Center
1-800-241-1620	Multimedia Support
1-800-742-2493	Multivendor Consulting
1-800-342-6672	OS/2 Information Line
1-800-237-5511	OS/2 Support Center
1-800-237-5511	OS/2 Support Line
1-303-924-4125	Parts Information
1-800-284-5933	Prodigy** Service (link problems)
1-914-962-0310	Prodigy User Questions
1-800-237-4824	PS/2 Trade-In Program
	PS/2 Loan for Learning
	PS/2 Lease from IBM Credit

* Trademark of the IBM Corporation.

** Trademark of the Prodigy Services Company.

Number	Information
1-800-742-2943	Solution Validation Lab
1-800-547-1283	Technical Coordinator Program SystemXtra* for Personal Systems LAN Automated Distribution/2 OS/2 Bulletin Board OS/2 Application Assistance Center
1-800-426-2622	Technical Services, Boca Raton (fee)
1-606-323-3000	Technical Support (typewriters/printers)
1-800-551-2832	Technical Solutions Magazine

IBM Canada Customer and Servicer Support

Number	Information
1-800-465-6600	Customer Relations
(416) 474-6666	Customer Relations - Toronto
1-800-465-6666	Customer Service Dispatch
1-800-263-2769	Customer Service Parts
1-800-465-2222	Customer Support Centre (ISC)
(416) 443-5701	Customer Service Repair Centre
1-800-465-1234	Helpcentre
1-800-465-7999	HelpClub* Registration
1-800-465-7999	IBM Direct
1-800-263-2769	Parts Orders, Exchange or Emergency
(514) 938-3022	PS Bulletin Board - Montreal
(416) 492-1823	PS Bulletin Board - Toronto
(416) 946-4255	PS Bulletin Board - Toronto
(604) 664-6466	PS Bulletin Board - Vancouver
1-800-661-7768	PS Marketing Support (PSMT)
1-800-465-1234	Publications Ordering
1-800-661-2131	Skill Dynamics* (Education)
(416) 443-5835	Warranty Claim Fulfillment (Fax)
(416) 443-5778	Warranty Claim Parts Enquiry
1-800-465-2222	Warranty Provider Support Hotline
(416) 946-1333	Warranty Provider Support - Toronto

We Want Your Comments!

Every effort has been made to provide complete and accurate technical information in this manual. However, if you find missing or inaccurate information, please fax any comments, corrections, or suggestions to 407-982-9825 (U.S.A.). Thank you.

* Trademark of the IBM Corporation.

Notices

References in this publication to IBM products, programs, or services do not imply that IBM intends to make these available in all countries in which IBM operates. Any reference to an IBM product, program or service is not intended to state or imply that only IBM's product, program, or service may be used. Any functionally equivalent product, program, or service that does not infringe any of IBM's intellectual property rights or other legally protectable rights may be used instead of the IBM product, program, or service. Evaluation and verification of operation in conjunction with other products, programs, or services, except those expressly designated by IBM, are the user's responsibility.

IBM may have patents or pending patent applications covering subject matter in this document. The furnishing of this document does not give you any license to these patents. You can send license inquiries, in writing, to the IBM Director of Licensing, IBM Corporation, 500 Columbus Avenue, Thornwood NY 10594, U.S.A.

Trademarks

The following terms, denoted by an asterisk (*) in this publication, are trademarks of the IBM Corporation in the United States and/or other countries:

AIX	AT	HelpCenter
HelpClub	HelpLearn	HelpWare
IBM	Micro Channel	OS/2
Personal System/2	Portmaster	PS/2
Presentation Manager	PS/ValuePoint	SystemXtra
ThinkPad	UltiMedia	XGA

The following terms, denoted by a double asterisk (**) in this publication, are trademarks of other companies:

80387SX	Intel Corporation
ActionMedia	Intel Corporation
Microsoft	Microsoft Corporation
Netware	Novell Corporation
Novell	Novell, Inc.
PCMCIA	Personal Computer Memory Card International Association
QAPLUS	DiagSoft, Inc.
SCO	The Santa Cruz Operation, Inc.
Triplett	Triplett Corporation
UNIX	UNIX System Laboratories, Inc.
VESA	Video Electronics Standards Association
Windows	Microsoft Corporation
XENIX	Microsoft Corporation

Index

Special Characters

(IML) initial machine load 382

Numerics

1-800 phone numbers 443
10BASE-T/10BASE2 Ethernet adapters, ISA 90
20 and 25 mhz processor boards 284
25 SX, system board locations 188
25-286, parts (FRUs) 223
25-286, system board locations 187
25, parts (FRUs) 223
25, system board locations 185, 186
25SX, parts (FRUs) 223
30-286, parts (FRUs) 229
30-286, system board locations 190
30, parts (FRUs) 227
30, system board locations 189
33, parts (FRUs) 231
33, system board locations 191
35, parts (FRUs) 233
35, system board locations 192
3509, parts (FRUs) 285
3510, parts (FRUs) 287
3511, parts (FRUs) 289
3532, parts (FRUs) 291, 295
40 (8540), parts (FRUs) 236
40, system board locations 192
50 (8550), parts (FRUs) 239
50, 50Z system board (upgrades) locations 194
50, memory problems 125
50, system board locations 193
53 (9553-xBx), system board (upgrade)
locations 195
53 (9553), parts (FRUs) 241
55 SX (8555), parts (FRUs) 243
55, memory problems 125
55, system board (upgrade) locations 197
55, system board locations 196
56 (8556), parts (FRUs) 246

56 (8556), system board locations 198
56 (9556), parts (FRUs) 257
56 (9556), system board locations 199
56, memory problems 125
57 (8557), parts (FRUs) 248
57 (8557), system board locations 198
57 (9557), system board locations 199
57 & M57 (9557), parts (FRUs) 260
57, memory problems 125
60 (8560), parts (FRUs) 251
60, 65, 80 system board (486DX2, 486DLC2
upgrades) locations 202
60, memory problems 125
60, system board locations 200
65 (8565), parts (FRUs) 251
65, memory problems 125
65, system board locations 201
70 , system board upgrade (486DX33, 486DLC2)
locations 205
70 (8570), parts (FRUs) 254
70, memory problems 125
70, processor boards 380
70, system board locations 203, 204
70/80 problems, 486DX33 processor upgrade 136
76 (9576), parts (FRUs) 257
76 (9576), system board locations 206
76, 77, option microprocessor jumper 130
76, memory problems 125
77 (9577), system board locations 206
77 & M77 (9577), parts (FRUs) 260
77, memory problems 125
80 (8580), parts (FRUs) 251
80, system board locations 207, 208
800 phone numbers 443
85 (9585) server, parts (FRUs) 273
85, memory problems 125
85, system board locations 209
8514/A, display adapter 109
90 (8590), parts (FRUs) 263
90, 95, error detection 407
90, 95, memory configurations 407
90, 95, processor board installation 135
90, 95, processor board matrix 126

- 90, 95, processor boards 380
- 90, 95, unique memory information 406
- 90, memory problems 125
- 90, system board locations 211
- 90/95, determining processor type 126
- 95 (9595) server, parts (FRUs) 277
- 95, memory problems 125
- 95, parts (FRUs) 273
- 95, remote power-on jumper 150
- 95, system board locations 212
- 95A disk array system 396
- 95A server, parts (FRUs) 280
- 96 8N1 error message 432
- 999XX errors 56

A

- abbreviations, terms, and acronyms, 438
- accessing system programs 384
- accessing the system partition 384
- ACPA/A advanced diagnostic tests 108
- acronyms, abbreviations, and terms 438
- adapter configuration options 90
- adapters and options matrix 311
- adapters, identifying 122
- adapters, memory-expansion 405
- additional override jumper functions 378
- address, I/O 90
- address, ROM 91
- advanced diagnostic tests, starting 384
- application program errors 433
- arbitration level 403, 404
- ASCII terminals
 - 96 8N1 console message (95) 432
 - acronym 438
 - configuration 431
 - customer satisfaction 800 number 443
 - HelpCenter 800 number 443
 - messages, error 432
 - operation 432
 - setup and menu selection 430
 - terminals 430
- AT bus, MAP 3

- AT bus, symptom-to-fru index 12
- audio output tone 108
- audio symptoms, Micro Channel 30
- automatic configuration, running 150, 429
- automatic restart 422
- available video memory 401

B

- backing up system partition 427
- beep codes, POST 387
- beep symptoms
 - beep, AT 13
 - beep, Micro Channel 29
 - no-beep, AT 12
 - no-beep, Micro Channel 27
- before replacing FRUs 56
- BIOS and POST in FLASH 382
- BIOS and POST in IML 382
- BIOS and POST in ROM 382
- BIOS and POST, upgrading 400

C

- cables, supported 404
- catalog, parts (FRUs) 222
- CD-ROM drives, parts 296
- changing enabled/disabled settings 180
- changing PS/ValuePoint ISA adapter configuration 91
- changing software configuration 408
- changing system configuration 408
- check point codes 383
- checking hard disk drive 56
- checking keyboard voltages 123
- checking power supply voltages 138
- checking startup sequence 56
- checkout fax/modem 112
- checkout procedures
 - AT bus 3
 - introduction 2
 - Micro Channel 19
- cleaning CD-ROM optical lens 413

- clock problems, real-time 150
- code format, error 115
- codes, CP 383
- codes, numeric error (micro channel) 33
- codes, numeric error, AT 15
- codes, understanding VPD 183
- combined FRUs, diagnosing 108
- comments about this manual 444
- common parts 295
- communication menu 431
- communication options 312
- compatibility matrix, drive and diskette 370
- compatibility mode, VGA 401
- compatibility mode, XGA 401
- complete system partition? 386
- configuration
 - ASCII terminal 431
 - changing software 408
 - changing system 408
 - memory, 90, 95 407
 - network 89
 - recording customized 429
 - running automatic 150, 429
 - SCSI device 418
- configuration options, adapter 90
- configuration, changing PS/ValuePoint ISA
 - adapter 91
- conflicts, memory-address 408
- connector
 - keyboard 404
 - keyboard voltages 123
 - mouse 404
 - pointing device 404
- considerations, display 111
- console selection 431
- controller on system board, SCSI 180
- controller, diskette-drive 404
- corrections to this manual 444
- cover lock 375
- cover-lock switches 375
- CP codes 383
- CSD version level, determining DOS 108
- current leakage 424

customized configuration, recording 429

D

- data rate switch settings 74
- data/fax modem diagnostics 112
- default settings, SCSI device 180
- description, systems 435
- determining DOS CSD version level 108
- determining failing memory location 125
- determining OS/2 version level 108
- determining processor type, 90/95 126
- device configurations, SCSI 418
- device default settings, SCSI 180
- device, missing non-scsi 24
- devices list, AT 11
- devices list, Micro Channel 23
- devices, handling discharge-sensitive 369
- devices, SCSI hard disk drives 409
- devices, uninterruptible power 424
- diagnosing combined FRUs 108
- diagnostic
 - LEDs, processor boards with 135
 - LEDs, processor boards without 135
 - PCMCIA (model 33) 133
 - procedures, network 74
 - tests, ACPA/A advanced 108
 - tests, SCSI 181
 - tests, starting advanced 384
- diagnostics, starting system program 425
- disable and enable settings 180
- discharge-sensitive devices, handling 369
- disk array system 396
 - array, disk 396
- diskette and drive compatibility matrix 370
- diskette drives, external, parts 298
- diskette-drive controller 404
- diskettes, system 383
- display
 - adapter 8514/A 109
 - considerations 111
 - self-test 110
- display-to-system compatibility 110

- displays, non-IBM 402
- displays, parts 297
- displays, repairable 297
- disturbances, power-line 423
- DOS CSD version level, determining 108
- drive and diskette compatibility matrix 370
- drive-startup function, selectable 420
- drives and devices, SCSI hard disk 409
- drives, external diskette, parts 298
- dumping extended diagnostic data information 434

E

- EEPROM 382
- electrical safety 366
- electrostatic devices, handling 369
- enable and disable settings 180
- error
 - 96 8N1 console message (95) 432
 - detection 90, 95 407
 - messages, ASCII terminal 432
 - storage 434
- error codes
 - format 115
 - numeric (micro channel) 33
 - numeric, AT 15
- error log, system 25, 433
- error log, viewing 433
- errors
 - 999XX 56
 - application program 433
 - Ethernet POST 85
 - IML and IPL 55
 - memory 405
 - micro channel adapter 433
 - network configuration 89
 - OS/2 trap 131
 - POST 383
 - printer 134
 - processor 433
 - system memory 433
 - token ring POST 79
 - types detected 433

- errors in this manual 444
- Ethernet adapter features diskette, ISA 90
- Ethernet adapter, testing 81
- Ethernet adapters, ISA 10BASE-T/10BASE2 90
- Ethernet POST errors 85
- exploded views
- extended diagnostic data information, dumping 434
- extension, NVRAM and NVRAM 381
- external devices attached to adapter, SCSI 417
- external diskette drive, parts 298

F

- failed hard disk drive, system partition 385
- failing memory location, determining 125
- failing memory, finding 125
- failures, using SCSI ID to isolate 181
- fax number for corrections to this manual 444
- fax/modem diagnostics 112
- features
 - power-on 380
 - power-supply 422
 - PS/2 systems 380
- features diskette, ISA Ethernet adapter 90
- finding failing memory 125
- FLASH memory 382
- FLASH, text messages 383
- format program, low-level 129
- format, error code 115
- FRU catalog 222
- FRU replacement strategy 1
- FRUs
 - See parts
- FRUs, before replacing 56
- FRUs, diagnosing combined 108
- function, SCSI terminator 414

G

- gain toggle, microphone 108
- general safety 365
- grounding requirements 369
- guide, safety inspection 368

H

- handling electrostatic discharge-sensitive devices 369
- hard disk drive
 - checking 56
 - head parking 374
 - jumper settings (ATA) 371
 - preparing for moving 374
 - replacing default hard disk drive 385
 - SCSI devices 409
 - switch settings (ATA) 371
- hard disk replacement strategy 1
- hardware maintenance reference 363
- head parking, hard disk 374
- help isolate failures, using SCSI ID 181
- high speed modem diagnostics 112
- hot-spare drive 398
 - array, disk 398
- hot-spare drive replacement 398
- how to change startup sequence 421
- how to use symptom-to-FRU index 114

I

- I/O address 90
- I/O base address 87
- IBM trademarks 445
- ID numbers, understanding SCSI 409
- ID, selecting SCSI 409
- ID, setting SCSI 411
- identifying adapters 122
- identifying memory-module kits 123
- IML and IPL errors 55
- IML, override jumpers 378
- information, related service 107
- initial machine load (IML) 382
- initial machine load errors 55
- initial program load errors 55
- input loop, microphone 108
- inspection guide, safety 368
- install processor board, 90, 95, 135
- installation, OS/2 problems 130

- installed devices list, AT 11
- installed devices list, Micro Channel 23
- internal devices attached to adapter, SCSI 417
- interrupt levels, IRQ 91
- introduction, checkout procedures 2
- IRQ interrupt levels 91
- ISA PS/ValuePoint 10BASE-T/10BASE2 Ethernet adapters 90
- ISA PS/ValuePoint Ethernet adapter features
 - diskette 90
- isolate failures, using SCSI ID 181

J

- Japanese keyboards, parts 299
- jumper, password override 376
- jumpers
 - option microprocessor, 76, 77 130
 - override functions 378
 - remote power-on, 95 150
 - setting motor-start 414
 - settings, hard disk drive (ATA) 371

K

- keep/remove enabled/disabled settings 180
- keyboard
 - keyboard connector 404
 - keyboard connector and pointing-device connector 404
 - keyboard voltages, checking 123
- keyboards, parts 298
- keybutton kits, parts 299

L

- LAN workstations, servicing 181
- leakage, current 424
- LEDs, processor boards with diagnostic 135
- LEDs, processor boards without diagnostic 135
- lens cleaning procedure 413
- level, determining DOS CSD version 108
- level, determining OS/2 version 108
- levels, IRQ interrupt 91

- list, installed devices, AT 11
- list, installed devices, Micro Channel 23
- location, determining failing memory 125
- locations, system board 185
- lock, cover 375
- lock, PCMCIA pc card override 134
- log, system error 25, 433
- loop, microphone input 108
- low-level format program, using 129

M

MAPs

- AT bus 3
- memory problems (80286 to 80486) 9
- memory problems (8086) 6
- Micro Channel 19

matrix

- drive and diskette compatibility 370
- options and adapters 311

memory

- address conflicts 408
- configurations, 90, 95 407
- determining type, size and speed 126
- errors 405
- errors, system 433
- expansion adapters 405
- finding failing 125
- information, 90, 95 406
- location, determining failing 125
- MAP (80286 to 80486) 9
- MAP (8086) 6
- problems 125
- system 405
- system-board 405
- type 1 processor boards 128
- type 2 processor boards 128
- type 3 processor boards 128
- video 401

memory-module kit identification 123

memory, FLASH 382

menu selection, ASCII terminal setup 430

micro channel

- adapter errors 433

- micro channel (*continued*)
 - checkout procedures & MAP 19
 - symptom-to-FRU index 26
- microphone gain toggle 108
- microphone input loop 108
- microprocessor jumper option, 76, 77 130
- microprocessors 380
- miscellaneous
 - symptoms 30
- mismatch problems, software/hardware 181
- missing non-SCSI device 24
- missing SCSI and non-SCSI devices 25
- missing SCSI device 24
- modem diagnostics 112
- monitors, parts 297
- motor-start jumper, setting 414
- mouse connector 404
- mouse, parts 298
- moving, preparing hard disk 374

N

- network
 - configuration errors 89
 - errors 89
 - service procedures 74
- new installation, OS/2 problems 130
- no-beep symptoms, AT 12
- no-beep symptoms, Micro Channel 27
- no-load operation 422
- non-ibm displays 402
- non-removable terminators 419
- non-scsi device, missing 24
- notices 445
- numbers, phone, 1-800 443
- numeric error codes (micro channel) 33
- numeric error codes, AT 15
- NVRAM and NVRAM extension 381

O

- OBI DASD Hot Swap Storage Expansion Enclosure,
parts (FRUs) 293

- operating voltage range 422
- operation, ASCII terminal 432
- operation, no-load 422
- optical drive, SCSI ID 414
- optical drives, rewritable, parts 305
- optical lens cleaning 413
- option microprocessor jumper, 76, 77 130
- options
 - communication 312
- options and adapters matrix 311
- OS/2
 - determining version level 108
 - installation problems 130
 - trap errors 131
- output tone, audio 108
- over-current protection 422
- over-voltage protection 422
- override jumper 376
- override jumper functions 378
- override jumper, 50, 60, 70, 80 377
- override jumper, 55 SX, 65 SX 377
- override jumpers, IML systems 378
- override, PCMCIA pc card lock 134

P

- parallel port 404
- parameters, selecting network configuration 87
- parking head, hard disk 374
- partition
 - backing up system 427
 - restoring system 428
 - system 425
 - upgrading system version 426
- parts
 - CD-ROM drives 296
 - common 295
 - displays 297
 - external diskette drive 298
 - Japanese keyboards 299
 - keyboards 298
 - keybutton kits 299
 - miscellaneous parts kits 300
 - model 25, 25-286, 25SX (8525) 223

parts (*continued*)

- model 30 (8530) 227
- model 30-286 (8530) 229
- model 33 (9533) 231
- model 35 (8535) 233
- model 3509 285
- model 3510 287
- model 3511 289
- model 3532 291
- model 40 (8540) 236
- model 50 (8550) 239
- model 53 (9553) 241
- model 55 SX (8555) 243
- model 56 (8556) 246
- model 56 (9556) 257
- model 57 (8557) 248
- model 57 & M57 (9557) 260
- model 60 (8560) 251
- model 65 (8565) 251
- model 70 (8570) 254
- model 76 (9576) 257
- model 77 & M77 (9577) 260
- model 80 (8580) 251
- model 85 (9585) server 273
- model 90 (8590) 263
- model 95 (8595) 273
- model 95 (9595) server 277
- model 95A server 280
- mouse 298
- OBI DASD Hot Swap Storage Expansion
 - Enclosure 293
- PC Server (8640) 267
- PC Server 500 (86XX) 270
- power cords 304
- rewritable optical drives 305
- SCSI adapter terminators 308
- serverguard adapter 306
- space-saving keyboards 299
- system board upgrades 295
- tools and miscellaneous 308
- wireless LAN adapter 309

parts catalog 222

password

- password override jumper 376
- passwords
 - privileged-access 378
 - removing power-on 376
 - unattended start mode, server mode 378
- PC cards 400
- PC Server (8640), parts (FRUs) 267
- PC Server 500 (86XX), parts (FRUs) 270
- PCMCIA
 - adapter features 400
 - adapter switch settings 134
 - diagnostics 133
 - pc card lock override 134
 - PC cards 400
- phone numbers, 1-800 443
- pointing-device connector 404
- port, parallel 404
- port, serial 403
- portables
- POST
 - beep codes 387
 - errors 383
 - upgrading 400
- POST and BIOS in FLASH 382
- POST and BIOS in IML 382
- POST and BIOS in ROM 382
- POST and BIOS, upgrading 400
- POST errors 383
- POST errors, Ethernet 85
- POST errors, token-ring 79
- POST overview 381
- POST, fast startup mode 382
- power cords, parts 304
- power devices, uninterruptible 424
- power supplies, system-unit 422
- power supply voltage check 138
- power-line disturbances 423
- power-on features 380
- power-on jumper 95, remote 150
- power-on password limitations 382
- power-on password, removing 376
- power-supply features 422
- preparing hard disk for moving 374

- printer errors 134
- privileged-access password 378
- problems
 - 70/80 486DX33 processor upgrade 136
 - during OS/2 installation 130
 - memory 125
 - real-time clock 150
 - software/hardware mismatch 181
 - undetermined 183
- processor
 - errors 433
 - model 90, 95 126
- processor boards
 - 20 MHz and 25 MHz 284
 - installation, 90, 95 135
 - matrix, 90, 95 126
 - memory type 1 128
 - memory type 2 128
 - memory type 3 128
 - model 70 380
 - model 90, 95 380
 - with diagnostic LEDs 135
 - without diagnostic LEDs 135
- processor type, 90/95 126
- processor upgrade problems 70/80, 486DX33 136
- program diagnostics, starting system 425
- program errors, application 433
- programs, updating system 426
- protection
 - over-current 422
 - over-voltage 422
 - short-circuit 422
 - surge 424
 - under-voltage 422
- PS/2 E diagnostics 133
- PS/2 types, descriptions 435
- PS/ValuePoint ISA adapter configuration,
 - changing 91

R

- range, operating voltage 422
- rate switch settings, data 74

- real-time clock problems 150
- rear-panel security option 375
- recording customized configuration 429
- reference section, this manual 363
- refresh rates possible 402
- related service information 107
- reliability 424
- remote power-on jumper 95 150
- removable terminators 419
- removals/replacements (portables)
- removing power-on password 376
- replacement strategy, FRU 1
- replacement strategy, hard disk 1
- replacing hard disk with a system partition 385
- requirements, grounding 369
- resolution possible 402
- resolving memory-address conflicts 408
- restart, automatic 422
- restoring system partition 428
- rewritable optical drive, SCSI ID 414
- rewritable optical drives, parts 305
- ROM 382
- ROM address 91
- running automatic configuration 150, 429

S

- safety 424
 - electrical 366
 - general 365
 - information 365
 - inspection guide 368
- SCSI
 - adapters, terminators 418
 - adapters, type 1 418
 - adapters, type 2 418
 - controller, system board 180
 - device configurations 418
 - device default settings 180
 - diagnostic tests 181
 - external devices attached to adapter 417
 - hard disk drives and devices 409
 - ID numbers, understanding 409
 - ID, jumper settings 412

SCSI (*continued*)

- ID, rewritable optical drive 414
- ID, selecting 409
- ID, setting 411
- ID, switch settings 411
- internal devices attached to adapter 417
- missing device 24
- SCSI and non-SCSI devices 25
- SCSI ID (using ID to isolate failures) 181
- system information 409
- terminator function 414
- terminator requirements 418
- terminators on system boards 419
- SCSI adapter terminators, parts 308
- security 375
- security option, rear-panel 375
- selectable drive-startup function 420
- selecting a SCSI ID 409
- selecting network configuration parameters 87
- selection, console 431
- self-test, display 110
- serial port 403
- server 85, system board locations 209
- serverguard adapter, parts (FRUs) 306
- service information, related 107
- service procedures
 - AT bus 3
 - introduction 2
 - Micro Channel 19
 - network 74
- service section, this manual 1
- servicing LAN workstations 181
- settings
 - changing enabled/disabled 180
 - data rate switch 74
 - enable and disable 180
 - keep/remove enabled/disabled 180
 - motor-start jumper 414
 - SCSI ID 411
- setup and menu selection, ASCII terminal 430
- short-circuit protection 422
- size, type, and speed, determining memory 126
- software configuration, changing 408

- software/hardware mismatch problems 181
- space-saving keyboards, parts 299
 - misc. parts kits 300
- specifications 435
- speed, type, and size, determining memory 126
- start mode (server mode), unattended 378
- starting advanced diagnostic tests 384
- starting diagnostics, system program 425
- starting system program diagnostics 425
- startup function, selectable drive 420
- startup sequence, changing 421
- startup sequence, checking 56
- stations, servicing LAN 181
- storage, error 434
- strategy, FRU replacement 1
- strategy, hard disk replacement 1
- suggestions about this manual 444
- supported cables 404
- surge protection 424
- switch settings
 - 70/80 486DX33 processor 136
 - data rate 74
 - hard disk drive (ATA) 371
- switches, tamper-evident 375
- symptom-to-FRU index
 - AT bus 12
 - how to use 114
 - Micro Channel 26
- symptoms
 - audio, Micro Channel 30
 - beep, AT 13
 - beep, Micro Channel 29
 - miscellaneous 30
 - miscellaneous, AT 13
 - no-beep, AT 12
 - no-beep, Micro Channel 27
- system
 - configuration, changing 408
 - diskettes 383
 - error log 25, 433
 - features 380
 - memory 405
 - memory errors 433
 - program diagnostics, starting 425

- system (*continued*)
 - programs, updating 426
 - SCSI information 409
- system board locations 185
- system board, SCSI controller 180
- system boards, SCSI terminators 419
- system partition 382, 384
 - backing up 427
 - complete? 386
 - information 425
 - option files 386
 - restoring 428
 - upgrading version 426
- system partition failures 385
- system specifications 435
- system-board memory 405
- system-to-display compatibility 110
- system-unit power supplies 422

T

- tamper-evident switches 375
- terminal configuration, ASCII 431
- terminator requirements, SCSI 418
- terminators
 - ASCII 430
 - function, SCSI 414
 - non-removable 419
 - on SCSI adapters 418
 - on system boards 419
 - removable 419
 - setup and menu selection, ASCII 430
- terminators, SCSI adapter, parts 308
- terms, acronyms, and abbreviations 438
- test
 - ACPA/A advanced diagnostic 108
 - Ethernet adapter 81
 - SCSI diagnostic 181
 - starting advanced diagnostic 384
 - token-ring adapter 74
- text messages, FLASH 383
- the error code format 115
- toggle, microphone gain 108

- token-ring adapter, testing 74
- token-ring POST errors 79
- tone, audio output tone 108
- tools and miscellaneous, parts 308
 - misc. tools and parts 308
- trademarks, IBM 445
- trademarks, other companies 445
- trap errors, OS/2 131
- type 1 processor boards, memory 128
- type 1 SCSI adapters 418
- type 2 processor boards, memory 128
- type 2 SCSI adapters, 418
- type 3 processor boards, memory 128
- type of processor, 90/95 126
- type, size and speed, determining memory 126
- types of errors detected 433

U

- u-bolt 375
- unattended start mode 378
- unattended start mode (server mode) 378
- under-voltage protection 422
- understanding SCSI ID numbers 409
- understanding VPD codes 183
- undetermined problems 183
- uninterruptible power devices 424
- unique memory information, 90, 95 406
- updating FLASH 382
- updating system programs 426
- upgradable POST and BIOS 400
- upgrading FLASH 382
- upgrading POST and BIOS 400
- upgrading the system partition version 426

V

- version level, determining DOS CSD 108
- version level, determining OS/2 108
- version, upgrading system partition 426
- VGA compatibility mode 401
- video 401
- video memory available 401

viewing error log 25, 433
voltage range, operating 422
voltages, checking keyboard 123
voltages, checking power supply 138
VPD codes, understanding 183

W

wireless LAN adapter, parts (FRUs) 309
workstations, servicing LAN 181

X

XGA compatibility mode 401

IBM

Part Number: 83G8990

Printed in U.S.A.

S52G-9971- 2

