



ThinkPad[®]
X4 UltraBase[™] Dock

User's Guide

Attention

Refer to the documentation that comes with your computer before installing the product.

Note

Be sure to keep your proof of purchase, because it might be required for warranty services. (See Appendix A, "Service and Support," on page A-1, Appendix B, "IBM Statement of Limited Warranty - Z125-4753-07 - 11/2002," on page B-1 and Appendix C, "Notices," on page C-1.)

First Edition (October 2003)

The following paragraph does not apply to the United Kingdom or any country where such provisions are inconsistent with local law:

INTERNATIONAL BUSINESS MACHINES CORPORATION PROVIDES THIS PUBLICATION "AS IS" WITHOUT ANY WARRANTY OF ANY KIND, EITHER EXPRESS OR IMPLIED, INCLUDING, BUT NOT LIMITED TO, THE LIMITED WARRANTIES OF MERCHANTABILITY OR FITNESS FOR A PARTICULAR PURPOSE. Some states do not allow disclaimers or express or implied warranties in certain transactions; therefore, this statement may not apply to you.

This publication could include technical inaccuracies or typographical errors. Changes are periodically made to the information herein; these changes will be incorporated in new editions of the publication. IBM may make improvements or changes in the products or the programs described in this publication at any time.

It is possible that this publication may contain reference to, or information about, IBM products (machines and programs), programming, or services that are not announced in your country. Such references or information must not be construed to mean that IBM intends to announce such IBM products, programming, or services in your country.

Requests for technical information about IBM products should be made to your IBM authorized dealer or your IBM marketing representative.

© Copyright International Business Machines Corporation 2003. All rights reserved. US Government Users Restricted Rights – Use, duplication or disclosure restricted by GSA ADP Schedule Contract with IBM Corp.

Contents

General safety guidelines	v
Service	v
Power cords and power adapters	v
Extension cords and related devices	vi
Plugs and outlets	vi
Batteries	vii
Heat and product ventilation	vii
CD and DVD drive safety	viii
About the IBM ThinkPad X4 UltraBase Dock	1-1
Product registration	1-1
Product description	1-1
Installation	1-2
Appendix A. Service and Support.	A-1
Online technical support	A-1
Telephone technical support	A-1
Appendix B. IBM Statement of Limited Warranty - Z125-4753-07 - 11/2002	B-1
<u>Part 2 - Country-unique Terms</u>	B-5
<u>Part 3 - Warranty Information</u>	B-19
Appendix C. Notices	C-1
Federal Communications Commission (FCC) statement	C-2
Trademarks	C-6

General safety guidelines

Always observe the following precautions to reduce the risk of injury and property damage.

Service

Do not attempt to service a product yourself unless instructed to do so by the IBM HelpCenter. Use only an IBM authorized service provider who is approved to repair your particular product.

Note: Some parts can be upgraded or replaced by the customer. These parts are referred to as Customer Replaceable Units, or CRUs. IBM expressly identifies CRUs as such, and provides documentation with instructions when it is appropriate for customers to replace those parts. You must closely follow all instructions when performing such replacements. Always make sure that the power is turned off and that the product is unplugged from any power source before you attempt the replacement. If you have any questions or concerns, contact the IBM HelpCenter.

Power cords and power adapters

Use only the power cords and power adapters supplied by the product manufacturer.

Never wrap a power cord around the power adapter or other object. Doing so can stress the cord in ways that can cause the cord to fray, crack or crimp. This can present a safety hazard.

Always route power cords so that they will not be walked on, tripped over, or pinched by objects.

Protect the cord and power adapters from liquids. For instance, do not leave your cord or power adapter near sinks, tubs, toilets, or on floors that are cleaned with liquid cleansers. Liquids can cause a short circuit, particularly if the cord or power adapter has been stressed by misuse. Liquids can also cause gradual corrosion of the power cord terminals and/or the connector terminals on the adapter which can eventually result in overheating.

Always connect power cords and signal cables in the correct order and ensure that all power cord connectors are securely and completely plugged into receptacles.

Do not use any power adapter that shows corrosion at the ac input pins and/or shows signs of overheating (such as deformed plastic) at the ac input or anywhere on the power adapter.

Do not use any power cords where the electrical contacts on either end show signs of corrosion or overheating or where the power cord appears to have been damaged in any way.

Extension cords and related devices

Ensure that extension cords, surge protectors, uninterruptible power supplies, and power strips that you use are rated to handle the electrical requirements of the product. Never overload these devices. If power strips are used, the load should not exceed the power strip input rating. Consult an electrician for more information if you have questions about power loads, power requirements, and input ratings.

Plugs and outlets

If a receptacle (power outlet) that you intend to use with your computer equipment appears to be damaged or corroded, do not use the outlet until it is replaced by a qualified electrician.

Do not bend or modify the plug. If the plug is damaged, contact the manufacturer to obtain a replacement.

Some products are equipped with a three-pronged plug. This plug fits only into a grounded electrical outlet. This is a safety feature. Do not defeat this safety feature by trying to insert it into a non-grounded outlet. If you cannot insert the plug into the outlet, contact an electrician for an approved outlet adapter or to replace the outlet with one that enables this safety feature. Never overload an electrical outlet. The overall system load should not exceed 80 percent of the branch circuit rating. Consult an electrician for more information if you have questions about power loads and branch circuit ratings.

Be sure that the power outlet you are using is properly wired, easily accessible, and located close to the equipment. Do not fully extend power cords in a way that will stress the cords.

Connect and disconnect the equipment from the electrical outlet carefully

Batteries

All IBM personal computers contain a non-rechargeable coin cell battery to provide power to the system clock. In addition many mobile products such as Thinkpad notebook PCs utilize a rechargeable battery pack to provide system power when in portable mode. Batteries supplied by IBM for use with your product have been tested for compatibility and should only be replaced with IBM approved parts.

Never attempt to open or service any battery. Do not crush, puncture, or incinerate batteries or short circuit the metal contacts. Do not expose the battery to water or other liquids. Only recharge the battery pack strictly according to instructions included in the product documentation.

Battery abuse or mishandling can cause the battery to overheat, which can cause gasses or flame to “vent” from the battery pack or coin cell. If your battery is damaged, or if you notice any discharge from your battery or the buildup of foreign materials on the battery leads, stop using the battery and obtain a replacement from the battery manufacturer.

Batteries can degrade when they are left unused for long periods of time. For some rechargeable batteries (particularly Lithium Ion batteries), leaving a battery unused in a discharged state could increase the risk of a battery short circuit, which could shorten the life of the battery and can also pose a safety hazard. Do not let rechargeable Lithium-Ion batteries completely discharge or store these batteries in a discharged state.

Heat and product ventilation

Computers generate heat when turned on and when batteries are charging. Notebook PCs can generate a significant amount of heat due to their compact size. Always follow these basic precautions:

- Do not leave the base of your computer in contact with your lap or any part of your body for an extended period when the computer is functioning or when the battery is charging. Your computer produces some heat during normal operation. Extended contact with the body could cause discomfort or, potentially, a skin burn.
- Do not operate your computer or charge the battery near flammable materials or in explosive environments.
- Ventilation slots, fans and/or heat sinks are provided with the product for safety, comfort, and reliable operation. These features might inadvertently become blocked by placing the product on a bed, sofa, carpet, or other flexible surface. Never block, cover or disable these features.

CD and DVD drive safety

CD and DVD drives spin discs at a high speed. If a CD or DVD is cracked or otherwise physically damaged, it is possible for the disc to break apart or even shatter when the CD drive is in use. To protect against possible injury due to this situation, and to reduce the risk of damage to your machine, do the following:

- Always store CD/DVD discs in their original packaging
- Always store CD/DVD discs out of direct sunlight and away from direct heat sources
- Remove CD/DVD discs from the computer when not in use
- Do not bend or flex CD/DVD discs, or force them into the computer or their packaging
- Check CD/DVD discs for cracks before each use. Do not use cracked or damaged discs

About the IBM® ThinkPad X4 UltraBase Dock

This section provides information on registering, installing, and using the ThinkPad X4 UltraBase Dock.

Product registration

Thank you for purchasing this IBM product. Please take a few moments to register your product and provide us with information that will help IBM to better serve you in the future. Your feedback is valuable to us in developing products and services that are important to you, as well as in developing better ways to communicate with you. Register your option on the IBM Web site at:

www.ibm.com/pc/register

IBM will send you information and updates on your registered product unless you indicate on the Web site questionnaire that you do not want to receive further information.

Product description

The ThinkPad X4 UltraBase Dock works only with computers in the ThinkPad X40 Series. It can extend the capabilities of your computer by enabling it to use the Ultrabay™ Slim and various optional devices.

Attention: To reduce the risk of fire, use only No.26 AWG or larger (thicker) telephone cable.

Attention: AC Adapter: Use the UL Listed Power Supply, rated 16 Vdc 3.5 A or equivalent.

Installation

Attention: Before you attach the X4 UltraBase Dock, connect the AC adapter as illustrated. Disconnect the AC adapter from your computer, or you might damage the AC adapter.

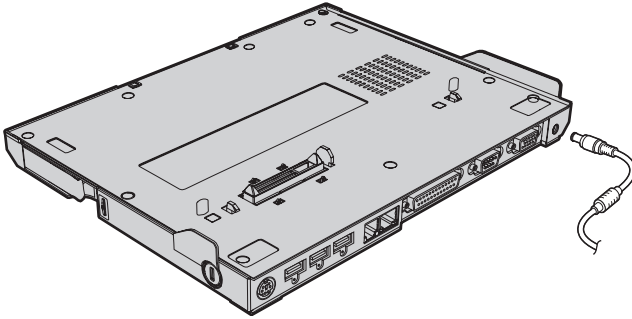

Security screw

A screw for securing the Ultrabay Slim is shipped with the X4 UltraBase Dock. By using this screw and a mechanical lock with the security keyhole of the X4 UltraBase Dock, you can secure your whole system, both your ThinkPad X40 Series computer and the X4 UltraBase Dock. For details about the security features of the X4 UltraBase Dock, refer to Access ThinkPad, your on-board help system for the computer.

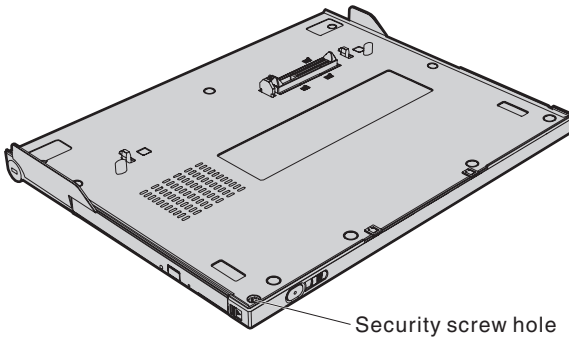

For details about setting up and using the X4 UltraBase Dock, refer to Access IBM or the Setup Poster that came with this option.

You can install a maximum of two batteries in your ThinkPad computer, as follows:

- One of the following installed in your computer:

- ThinkPad X40 Series 4-Cell Li-Ion Battery
- ThinkPad X40 Series 8-Cell Li-Ion Battery
- One of the following attached to the docking connector:
 - ThinkPad X40 Series Extended Life Battery
 - ThinkPad Ultrabay Slim Li-Ion Battery, installed in the X4 UltraBase Dock

Sobre o IBM® ThinkPad X4 UltraBase Dock

Esta seção fornece informações sobre registro, instalação e utilização do ThinkPad X4 UltraBase Dock.

Registro do Produto

Obrigado por adquirir este produto IBM. Reserve alguns minutos para registrar o produto e fornecer informações que ajudem a IBM a melhor servi-lo no futuro. Seu feedback é importante para desenvolvermos produtos e serviços úteis a você, bem como para desenvolvermos melhores formas de nos comunicarmos com você. Registre seu opcional no Web site da IBM em:

www.ibm.com/pc/register

A IBM enviará a você informações e atualizações sobre o produto registrado, a menos que seja indicado no questionário do site que você não deseja receber informações adicionais.

Descrição do Produto

O ThinkPad X4 UltraBase Dock funciona apenas com computadores no ThinkPad X40 Series. Ele pode estender as capacidades de seu computador ativando-o para utilizar o Ultrabay™ Slim e vários dispositivos opcionais.

Atenção: Para reduzir o risco de incêndio, utilize apenas o cabo de telefone AWG No.26 ou maior (mais fino).

Atenção: AC Adapter: Utilize a Fonte de Alimentação Listada UL, com taxa de 16 Vdc 3.5 A ou equivalente.

Instalação

Atenção: Antes de conectar o X4 UltraBase Dock, conecte o adaptador AC conforme ilustrado. Desconecte o adaptador AC do seu computador ou causará danos no adaptador AC.

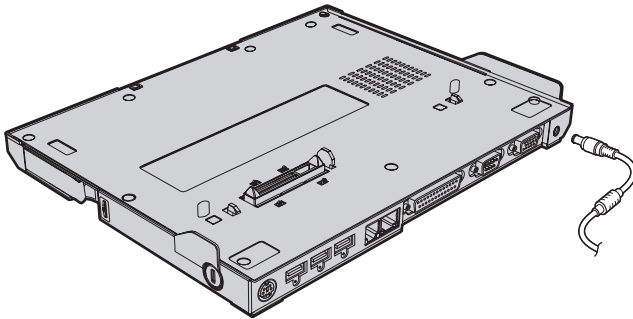

Parafuso de Segurança

Um parafuso para assegurar o Ultrabay Slim é enviado junto com o X4 UltraBase Dock. Utilizando este parafuso e um travamento mecânico com o orifício de chave de segurança do X4 UltraBase Dock, você poderá assegurar todo o seu sistema, seu computador ThinkPad X40 Series e o X4 UltraBase Dock. Para obter detalhes sobre os recursos de segurança do X4 UltraBase Dock, consulte [Acessar o ThinkPad](#), seu sistema de ajuda on-board para o computador.

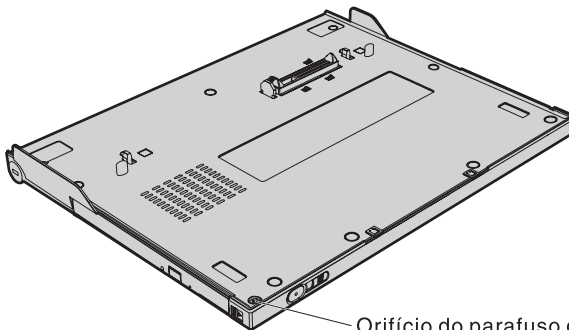

Orifício do parafuso de segurança

Para obter detalhes sobre a configuração e a utilização do X4 UltraBase Dock, consulte o Access IBM ou o Folheto de Configuração que acompanha este opcional.

Você pode instalar no máximo duas baterias no seu computador ThinkPad, como segue:

- Uma das seguintes instaladas no seu computador:
 - Bateria ThinkPad X40 Series 4-Cell Li-Ion
 - Bateria ThinkPad X40 Series 8-Cell Li-Iony
- Uma das seguintes conectada ao conector de acoplamento:
 - Bateria ThinkPad X40 Series Extended Life
 - Bateria ThinkPad Ultrabay Slim Li-Ion, instalada no X4 UltraBase Dock

Dok IBM® ThinkPad X4 UltraBase

Tato část obsahuje informace o registraci, instalaci a používání doku ThinkPad X4 UltraBase.

Registrace produktu

Děkujeme vám za zakoupení tohoto produktu od IBM. Prosíme zaregistrujte si tento produkt a poskytněte nám údaje, které IBM pomohou, aby vám v budoucnosti mohla lépe sloužit. Vaše informace nám pomohou ve vývoji produktů a služeb, které jsou pro vás důležité, a také při zavádění lepší komunikace s vámi. Produkt zaregistrujte na webové stránce:

www.ibm.com/pc/register

IBM vám bude posílat informace a aktualizace k zaregistrovanému produktu, pokud ve formuláři na webové stránce neuvedete, že nechcete dostávat další informace.

Popis produktu

Dok ThinkPad X4 UltraBase funguje pouze s počítači ThinkPad X40 Series. Rozšiřuje schopnosti vašeho počítače o možnost používat zařízení typu Ultrabay™ Slim a další volitelná zařízení.

Upozornění: Nebezpečí požáru snižíte použitím kabelu No.26 AWG nebo silnějšího telefonního kabelu.

Upozornění: Adaptér napájení: Používejte pouze doporučené adaptéry napájení, s hodnotami 16 V= 3,5 A, nebo ekvivalentní.

Instalace

Upozornění: Před připojením doku X4 UltraBase připojte adaptér napájení podle na obrázku. Odpojte adaptér napájení od počítače, jinak by se mohl adaptér napájení poškodit.

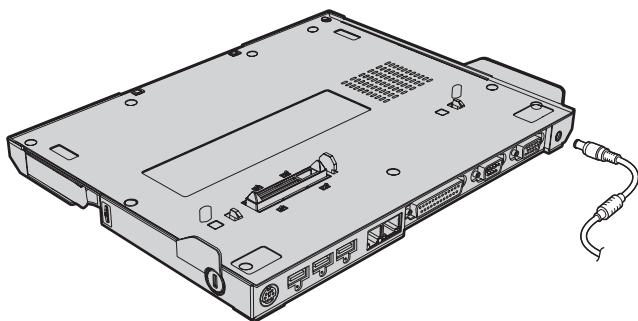

Zabezpečovací šroub

S dokem X4 UltraBase je dodáván zabezpečovací šroub. Pomocí tohoto šroubu, mechanického zámku a zabezpečovacího otvoru doku X4 UltraBase je možné zabezpečit celý systém, počítač ThinkPad X40 Series i dok X4 UltraBase. Podrobnosti o možnostech zabezpečení doku X4 UltraBase naleznete v online systému nápovědy Access ThinkPad.

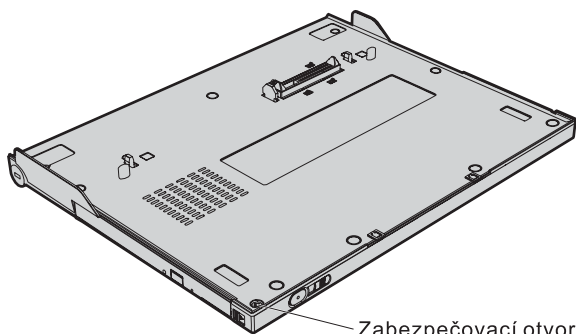

Podrobnosti o nastavení a používání doku X4 UltraBase naleznete v systému nápovědy Access IBM nebo v návodu pro instalaci dodaném s produktem.

S počítačem ThinkPad můžete používat až dvě baterie v následujících konfiguracích:

- Jedna z níže uvedených baterií instalovaná v počítači:
 - baterie ThinkPad X40 Series 4-Cell Li-Ion
 - baterie ThinkPad X40 Series 8-Cell Li-Ion

- Jedna z níže uvedených baterií připojená k dokovacímu konektoru:
 - baterie ThinkPad X40 Series Extended Life
 - baterie ThinkPad Ultrabay Slim Li-Ion, instalovaná v doku X4 UltraBase

Station d'accueil IBM ThinkPad X4 UltraBase

La présente section fournit des informations relatives à l'enregistrement, l'installation et l'utilisation de la station d'accueil ThinkPad X4 UltraBase.

Enregistrement du produit

Merci d'avoir acheté ce produit IBM. Veuillez consacrer quelques instants à l'enregistrement de ce produit. Vous fournirez ainsi des informations qui aideront IBM à mieux vous servir. Vos commentaires nous permettent de développer des produits et services importants pour vous et nous aident à améliorer nos méthodes de communication. Enregistrez votre option sur le site Web d'IBM, à l'adresse suivante :

www.ibm.com/pc/register

IBM vous enverra des informations et des mises à jour relatives au produit que vous avez enregistré, sauf si vous précisez dans le questionnaire du site Web que vous ne souhaitez pas recevoir d'autres informations.

Description du produit

La station d'accueil ThinkPad X4 UltraBase n'est compatible qu'avec les ordinateurs de la gamme ThinkPad X40 Series. Elle peut étendre les fonctions de votre ordinateur en lui permettant d'utiliser l'unité extra-plate Ultrabay Slim et divers périphériques en option.

Avertissement : Pour réduire le risque d'incendie, utilisez uniquement un câble téléphonique de référence "26 AWG" ou un câble présentant des caractéristiques supérieures.

Avertissement : Bloc d'alimentation : utilisez le bloc d'alimentation UL répertorié, 16 Vcc 3,5 A ou équivalent.

Installation

Avertissement : Avant de connecter la station d'accueil X4 UltraBase, connectez le bloc d'alimentation comme indiqué sur l'illustration. Pour éviter de l'endommager, déconnectez le bloc d'alimentation de l'ordinateur.

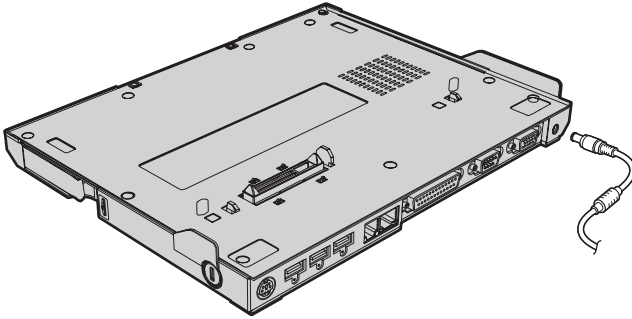

Vis de sécurité

Une vis permettant de verrouiller l'unité extra-plate Ultrabay Slim est livrée avec la station d'accueil X4 UltraBase. En plaçant cette vis ainsi qu'un verrou mécanique à l'emplacement du dispositif de sécurité de la station X4 UltraBase, vous pouvez sécuriser l'ensemble du système, c'est-à-dire votre ordinateur ThinkPad X40 Series et la station d'accueil X4 UltraBase. Pour plus de détails sur les dispositifs de sécurité de la station d'accueil X4 UltraBase, consultez Access ThinkPad, le système d'aide intégré de l'ordinateur.

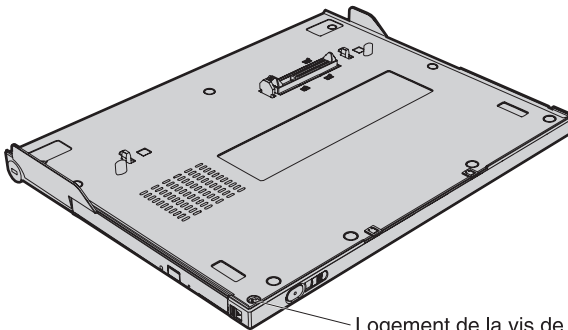

Pour plus de détails sur la configuration et l'utilisation de la station d'accueil X4 UltraBase, reportez-vous à Access IBM ou au livret d'installation fourni avec cette option.

Vous pouvez installer deux batteries au maximum dans votre ordinateur ThinkPad, comme suit :

- Une des batteries suivantes installée dans l'ordinateur :
 - Batterie au Lithium-Ion à 4 cellules ThinkPad X40 Series
 - Batterie au Lithium-Ion à 8 cellules ThinkPad X40 Series
- Une des batteries suivantes branchée sur le connecteur de station d'accueil :
 - Batterie longue durée ThinkPad X40 Series
 - Batterie au Lithium-Ion pour unité extra-plaie ThinkPad Ultrabay Slim, installée dans la station d'accueil X4 UltraBase

Informationen zur vorliegenden IBM® ThinkPad X4 UltraBase-Andockstation

In diesem Abschnitt finden Sie Informationen zum Registrieren, Installieren und Verwenden der ThinkPad X4 UltraBase-Andockstation.

Produktregistrierung

Vielen Dank, dass Sie sich für dieses IBM Produkt entschieden haben. Bitte nehmen Sie sich etwas Zeit, um Ihr Produkt zu registrieren und uns die Informationen zu liefern, die IBM benötigt, um Ihnen in Zukunft noch bessere Dienste leisten zu können. Ihre Rückmeldung ist für uns sehr wertvoll, sowohl zur Entwicklung von Produkten und Services als auch zur Entwicklung besserer Kommunikationsmöglichkeiten zwischen Ihnen und IBM. Registrieren Sie die Zusatzeinrichtung auf der IBM Website unter folgender Adresse:

www.ibm.com/pc/register

IBM sendet Ihnen Informationen und Aktualisierungen zu Ihrem registrierten Produkt, falls Sie im Fragebogen auf der Website nicht angegeben haben, dass Sie keine weiteren Informationen erhalten möchten.

Produktbeschreibung

Die ThinkPad X4 UltraBase-Andockstation kann nur zusammen mit Computern der ThinkPad X40 Series verwendet werden. Die Funktionalität Ihres Computers kann durch die Verwendung des flachen Ultrabay™-Laufwerks und weiterer optionaler Einheiten erweitert werden.

Achtung: Um die Gefahr von Verbrennungen zu vermeiden, verwenden Sie nur Telefonkabel mit 26 AWG (oder dicker).

Achtung: Netzteil: Verwenden Sie das UL-geprüfte Netzteil für 16 Volt (Gleichstrom) und 3,5 Ampere oder ein entsprechendes Netzteil.

Sie können maximal zwei Akkus in Ihrem ThinkPad installieren:

- Sie können einen der folgenden Akkus im Computer installieren:
 - Akku vom Typ ThinkPad X40 Series 4-Cell Li-Ion Battery
 - Akku vom Typ ThinkPad X40 Series 8-Cell Li-Ion Battery
- Sie können einen der folgenden Akkus am Andockstecker anbringen:
 - Akku vom Typ ThinkPad X40 Series Extended Life Battery (Akku mit verlängerter Lebensdauer)
 - Akku vom Typ ThinkPad Ultrabay Slim Li-Ion Battery, in der X4 UltraBase-Andockstation installiert

Informazioni su IBM® ThinkPad X4 UltraBase Dock

Questa sezione fornisce informazioni sulla registrazione, sull'installazione e sull'utilizzo del prodotto ThinkPad X4 UltraBase Dock.

Registrazione del prodotto

Grazie per aver acquistato questo prodotto IBM. Effettuare la registrazione del prodotto e fornire le informazioni per rendere migliore l'assistenza in futuro. La collaborazione è importante per lo sviluppo dei prodotti e dei servizi, oltre allo sviluppo delle comunicazioni. Registrare l'opzione sul sito Web IBM all'indirizzo:

www.ibm.com/pc/register

L'IBM invierà le informazioni e gli aggiornamenti relativi al prodotto registrato a meno che non venga indicato nel questionario del sito web che non si desidera ricevere ulteriori informazioni.

Descrizione del prodotto

ThinkPad X4 UltraBase Dock può essere utilizzato solo con i computer di tipo ThinkPad X40 Series. E' in grado di estendere le capacità del proprio computer se utilizzato con Ultrabay™ Slim ed altre periferiche facoltative.

Attenzione: Per ridurre il rischio di incendio, utilizzare solo No.26 AWG o un cavo telefonico superiore (più doppio).

Attenzione: Adattatore CA: utilizzare un alimentatore UL Listed Power Supply, classificato 16 Vcc 3.5 A o equivalente.

Installazione

Attenzione: Prima di installare X4 UltraBase Dock, collegare l'adattatore CA come illustrato. Scollegare l'adattatore CA dal computer, altrimenti l'adattatore potrebbe danneggiarsi.

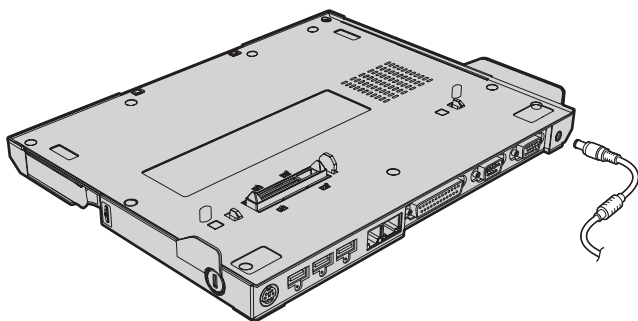

Vite di sicurezza

Una vite di sicurezza per Ultrabay Slim viene fornita con il prodotto X4 UltraBase Dock. Utilizzando questa vite e un blocco meccanico per X4 UltraBase Dock, è possibile proteggere l'intero sistema, sia il computer ThinkPad X40 Series, sia X4 UltraBase Dock. Per ulteriori dettagli sulle funzioni di sicurezza del prodotto X4 UltraBase Dock, fare riferimento alla sezione Access ThinkPad.

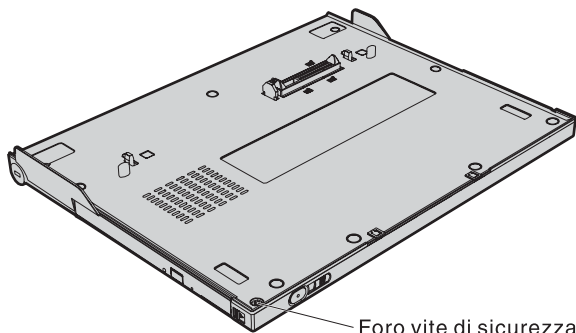

Per informazioni sull'installazione e sull'utilizzo del prodotto X4 UltraBase Dock, consultare la sezione Access IBM o Setup Poster fornita con questo pacchetto.

E' possibile installare massimo due batterie sul computer ThinkPad, come segue:

- Installare uno dei seguenti componenti sul computer:
 - ThinkPad X40 Series 4-Cell Li-Ion
 - ThinkPad X40 Series 8-Cell Li-Ion
- Collegare uno dei seguenti componenti al connettore docking:
 - ThinkPad X40 Series Extended Life Battery
 - ThinkPad Ultrabay Slim Li-Ion Battery, in X4 UltraBase Dock

关于 IBM® ThinkPad X4 UltraBase 扩展坞

本节提供有关注册、安装和使用 ThinkPad X4 UltraBase 扩展坞的信息。

产品注册

感谢您购买本 IBM 产品。请花点时间注册您的产品，并向我们提供有助于 IBM 将来更好地为您服务的信息。您的反馈对于我们在开发对您相当重要的产品和服务，以及寻找更好的方式以便与您沟通方面具有重要价值。请在以下 IBM Web 站点注册您的选件：

www.ibm.com/pc/register

IBM 将向您发送有关您所注册产品的信息和更新，除非您在 Web 站点的调查表中表明您不希望接收进一步的信息。

产品描述

ThinkPad X4 UltraBase 扩展坞只与 ThinkPad X40 系列的计算机一起配合使用。该扩展坞通过使计算机能够使用 Ultrabay™ Slim 和各种可选设备来扩展计算机的能力。

警告： 为减少火灾的危险性，请仅使用 No.26 AWG 或更大（更粗）的电话电缆。

警告： 交流电源适配器：请使用 UL 列出的电源（额定值为 16 Vdc 3.5 A）或同等电源。

安装

警告： 在连接 X4 UltraBase 扩展坞之前，请如图所示连接交流电源适配器。请断开交流电源适配器与计算机的连接，否则可能损坏交流电源适配器。

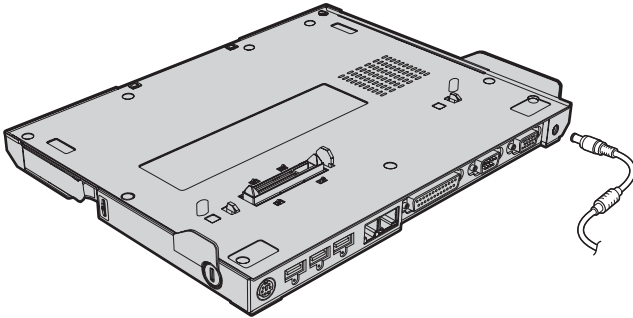

安全螺钉

固定 Ultrabay Slim 的螺钉随 X4 UltraBase 扩展坞一起提供。通过将该螺钉和一把机械锁与 X4 UltraBase 扩展坞的安全锁孔配合使用，可以保护整个系统，即 ThinkPad X40 系列计算机和 X4 UltraBase 扩展坞。有关 X4 UltraBase 扩展坞安全功能的详细信息，请参考计算机的联机帮助系统 Access ThinkPad。

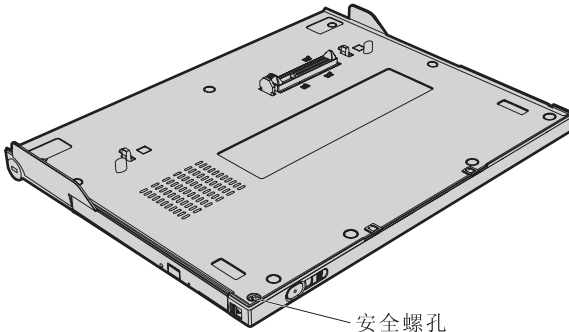

有关安装和使用 X4 UltraBase 扩展坞的详细信息，请参考 Access IBM 或随该选件一起提供的安装海报。

ThinkPad 计算机中最多可以安装两块电池，如下所示：

- 已在您的计算机上安装了以下电池之一：
 - ThinkPad X40 系列四单元锂离子电池
 - ThinkPad X40 系列八单元锂离子电池
- 已将以下电池之一连接到扩展坞接口：

- ThinkPad X40 系列节电电池
- ThinkPad Ultrabay Slim 锂离子电池, 安装在 X4 UltraBase 扩展坞中

Informácie o IBM® ThinkPad X4 UltraBase Dock

Táto časť poskytuje informácie o registrácii, inštalácii a používaní ThinkPad X4 UltraBase Dock.

Registrácia produktu

Ďakujeme za nákup tohto produktu IBM. Venujte, prosím, niekoľko momentov registrácii tohto produktu a uvedeniu informácii, ktoré firme IBM umožnia poskytovať vám v budúcnosti lepšie služby. Vaše odpovede sú hodnotné pri vývoji produktov a služieb, ktoré sú pre vás dôležité, ako aj pri vývoji lepších spôsobov našej komunikácie s vami. Zaregistrujte si váš produkt na webovej stránke IBM:

www.ibm.com/pc/register

Pokiaľ v dotazníku na webovej stránke neoznámíte, že si nepravete dostávať ďalšie informácie, bude vám firma IBM zasielať informácie a aktualizácie k vašim zaregistrovaným produktom.

Popis produktu

ThinkPad X4 UltraBase Dock funguje len s počítačmi ThinkPad X40 Series. Môže rozšíriť schopnosti vášho počítača tým, že mu umožní používať Ultrabay™ Slim a rôzne voliteľné zariadenia.

Upozornenie: Na zníženie rizika požiaru používajte len telefónny kábel No.26 AWG alebo väčší (hrubší).

Upozornenie: AC Adaptér: Používajte napájací zdroj z UL, s hodnotou 16 Vdc 3.5 A alebo ekvivalentný.

Inštalácia

Upozornenie: Pred pripojením X4 UltraBase Dock zapojte podľa nasledujúceho obrázka AC adaptér. Odpojte AC adaptér z počítača lebo by ste ho mohli poškodiť.

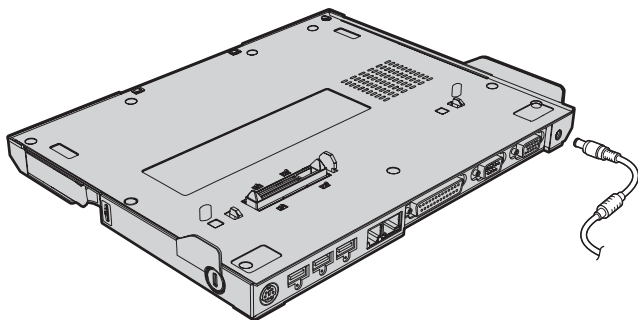

Bezpečnostná skrutka

Pre zabezpečenie Ultrabay Slim sa s X4 UltraBase Dock dodáva skrutka. Pomocou tejto skrutky a bezpečnostného mechanického zámku X4 UltraBase Dock, môžete zabezpečiť celý váš systém, počítač ThinkPad X40 Series aj X4 UltraBase Dock. Podrobné informácie o bezpečnostných funkciách X4 UltraBase Dock nájdete v Access ThinkPad, zabudovanom systéme pomoci vášho počítača.

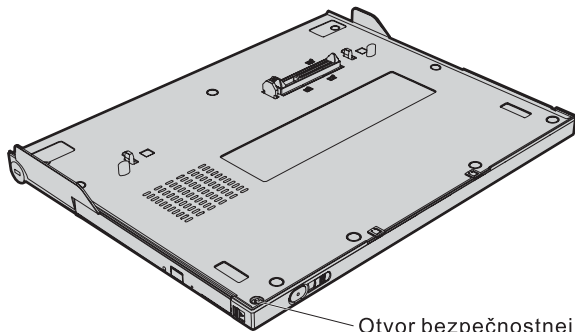

Otvor bezpečnostnej skrutky

Podrobnosti o nastavení a používaní X4 UltraBase Dock nájdete v Access IBM alebo na karte o nastavovaní, ktorá bola dodaná spolu s týmto produktom.

Do vášho počítača ThinkPad môžete nainštalovať maximálne dve batérie:

- Vo vašom počítači je nainštalovaná jedna z nasledujúcich batérií:
 - ThinkPad X40 Series 4-Cell Li-Ion batéria
 - ThinkPad X40 Series 8-Cell Li-Ion batéria

- K dokovému konektoru je pripojená jedna z nasledujúcich batérií:
 - ThinkPad X40 Series Extended Life batéria
 - ThinkPad Ultrabay Slim Li-Ion batéria, nainštalovaná v X4 UltraBase Dock

Acerca de IBM® ThinkPad X4 UltraBase Dock

En este apartado se proporciona información acerca del registro, instalación y utilización de ThinkPad X4 UltraBase Dock.

Registro del producto

Gracias por adquirir este producto de IBM. Tómese unos minutos para registrar su producto y facilitarnos información que ayudará a IBM a prestarle un mejor servicio en el futuro. Su opinión es de gran utilidad para poder desarrollar productos y servicios importantes para su disposición, así como para desarrollar mejores maneras de ponernos en contacto con usted. Registre su opción en el sitio web de IBM en la dirección:

www.ibm.com/pc/register

IBM le enviará información y actualizaciones sobre el producto registrado a menos que indique lo contrario en el cuestionario del sitio web.

Descripción del producto

ThinkPad X4 UltraBase Dock sólo funciona con sistemas ThinkPad X40 Series. Se pueden ampliar las funciones del sistema de que disponga habilitando la utilización de Ultrabay™ Slim y varios dispositivos opcionales.

Atención: Si desea reducir el peligro de incendio, utilice sólo un cable N°26 AWG (sistema americano de medida de grosor de cables) o un cable de teléfono más grueso.

Atención: Adaptador de CA: Utilice la fuente de alimentación que se lista en UL, a 16 V CC 3,5 A o equivalente.

Instalación

Atención: Antes de conectar X4 UltraBase Dock, conecte el adaptador de CA como se indica en la ilustración. Desconecte el adaptador de CA del sistema para evitar el riesgo de daños en el adaptador.

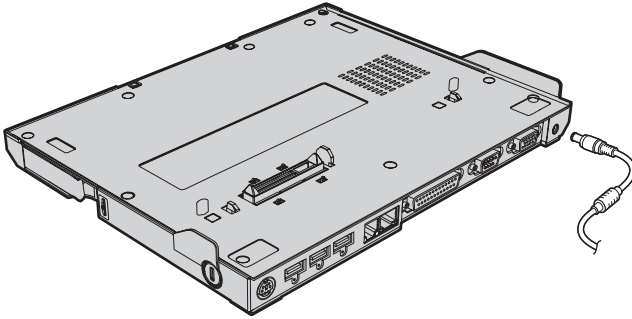

Tornillo de seguridad

X4 UltraBase Dock incluye un tornillo de seguridad para Ultrabay Slim. Si se utiliza este tornillo y un bloqueo mecánico con la cerradura de seguridad de X4 UltraBase Dock, podrá proteger todo el sistema, tanto el sistema ThinkPad X40 Series como X4 UltraBase Dock. Si desea obtener detalles acerca de los dispositivos de seguridad de X4 UltraBase Dock, consulte Access ThinkPad, el sistema de ayuda interno del sistema.

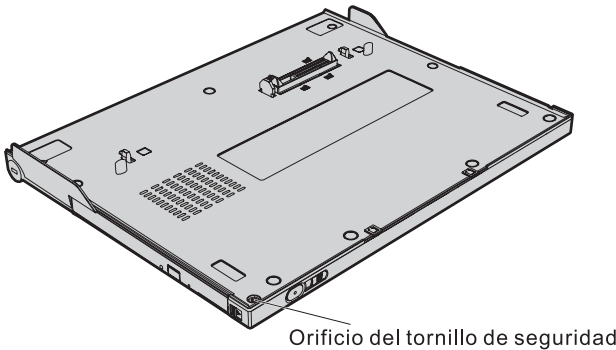

Si desea obtener detalles sobre la instalación y utilización de X4 UltraBase Dock, consulte Access IBM o el póster de instalación incluido con esta opción.

Se puede instalar un máximo de dos baterías en el sistema ThinkPad, tal como se indica a continuación:

- Una de las siguientes instalada en el sistema:

- Batería de iones de litio de 4 células para ThinkPad X40 Series
- Batería de iones de litio de 8 células para ThinkPad X40 Series
- Una de las siguientes conectadas al conector de acoplamiento:
 - Batería de larga duración para ThinkPad X40 Series
 - Batería de iones de litio para ThinkPad Ultrabay Slim, instalada en X4 UltraBase Dock

關於 IBM® ThinkPad X4 UltraBase 擴充基座

本章節提供關於註冊、安裝和使用 ThinkPad X4 UltraBase 擴充基座的資訊。

產品註冊

感謝您購買 IBM 產品。請利用一些時間註冊產品以及提供資訊；這樣可以協助 IBM 在未來提供更好的服務。對於開發重要產品和服務，以及更好的溝通方法上，您的回應對我們非常有價值。請在以下的 IBM 網站註冊您的選用設備：

www.ibm.com/pc/register

如果您沒有在 IBM 網站的問卷中指出以後不要收到資訊，則 IBM 會將註冊產品的資訊和更新傳送給您。

產品說明

ThinkPad X4 UltraBase 擴充基座只能用於 ThinkPad X40 系列的電腦。它可以讓電腦能夠使用 Ultrabay™ Slim 和多種選用裝置，進而延伸電腦的功能。

警告： 爲了減少發生火災的危險，請務必使用 No.26 AWG（含）以上（絕緣層更厚的）的電話線。

警告： AC 整流器：請使用 16 Vdc 3.5 A 或同級的 UL Listed 電源供應器。

安裝

警告： 在接上 X4 UltraBase 擴充基座之前，請先按照圖示連接 AC 整流器。請先取下電腦上的 AC 整流器，否則可能會使 AC 整流器損壞。

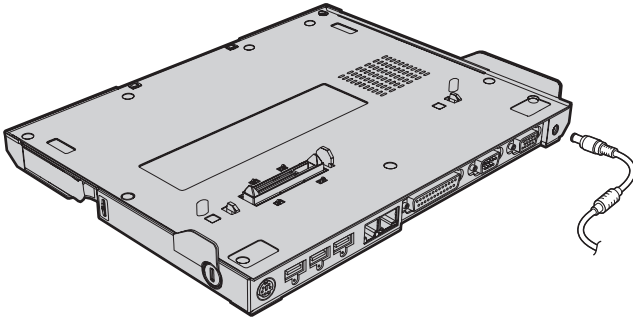

固定用螺絲

X4 UltraBase 擴充基座隨附了固定 Ultrabay Slim 的螺絲。在 X4 UltraBase 擴充基座的安全鑰匙孔上使用此螺絲和機械鎖，可以保障 ThinkPad X40 系列電腦和 X4 UltraBase 擴充基座這整個系統的安全。關於 X4 UltraBase 擴充基座的安全功能詳細說明，請參照電腦的內建說明系統 - Access ThinkPad。

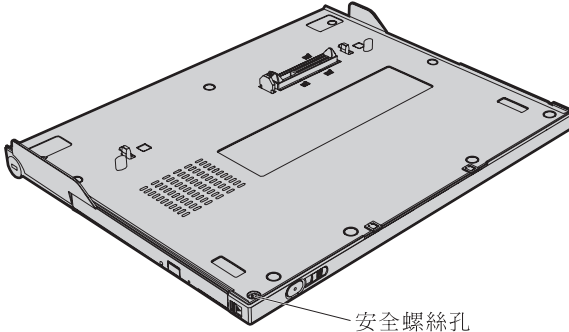

關於設定和使用 X4 UltraBase 擴充基座的詳細資訊，請參照 Access IBM 或本選用裝置的「安裝海報」。

您最多可以在 ThinkPad 電腦上安裝以下兩個電池：

- 下列之一可安裝於電腦：
 - ThinkPad X40 系列 4-Cell 鋰電池
 - ThinkPad X40 系列 8-Cell 鋰電池
- 下列之一可安裝到基座：

- ThinkPad X40 系列 Extended Life Battery
- ThinkPad Ultrabay Slim 鋰電池，安裝於 X4 UltraBase 擴充基座

IBM® ThinkPad X4 UltraBase Dock Hakkında

Bu bölümde, ThinkPad X4 UltraBase Dock ürününün kaydedilmesine, kurulmasına ve kullanılmasına ilişkin bilgiler yer alır.

Ürün Kaydı

Bu IBM ürününü satın aldığınız için teşekkür ederiz. Ürününüzü kaydetmek ve IBM'den gelecekte daha sağlıklı hizmet alabilmeniz için gerekli bilgileri vermek üzere lütfen birkaç dakikanızı ayırın. Görüşleriniz yeni ürünler ve hizmetler geliştirmenin yanı sıra, sizinle daha iyi iletişim kurmamızı sağladığından bizim için değerlidir. Seçeneğinizi şu adresteki IBM Web sitesine kaydedin:

www.ibm.com/pc/register

Web sitesi anketinde ürünle ilgili daha fazla bilgi almak istemediğinizi belirtmediğiniz takdirde, IBM size kaydedilen ürününüzle ilgili bilgi ve güncellemeler gönderecektir.

Ürün Tanımı

ThinkPad X4 UltraBase Dock yalnızca ThinkPad X40 Series kapsamındaki bilgisayarlarla birlikte çalışır. Bu ürün, bilgisayarınızın yeteneklerini, bilgisayarınızın Ultrabay™ Slim ve çeşitli isteğe bağlı aygıtları kullanabilmesini sağlayarak büyük ölçüde geliştirebilir.

Uyarı: Yangın riskini azaltmak için yalnızca No.26 AWG ya da daha geniş (kalın) telefon kablosu kullanın.

Uyarı: AC Bağdaştırıcısı: 16 Vdc 3.5 A ya da eşdeğer güce sahip, UL Listed Power Supply (UL Tarafından Listelenen Güç Kaynağı) ürününü kullanın.

Kuruluş

Uyarı: X4 UltraBase Dock ürününü bağlamadan önce, AC bağdaştırıcısını şekilde gösterildiği biçimde takın. AC bağdaştırıcısının bilgisayarınızla olan bağlantısını kesin, tersi durumda, AC bağdaştırıcısına zarar verebilirsiniz.

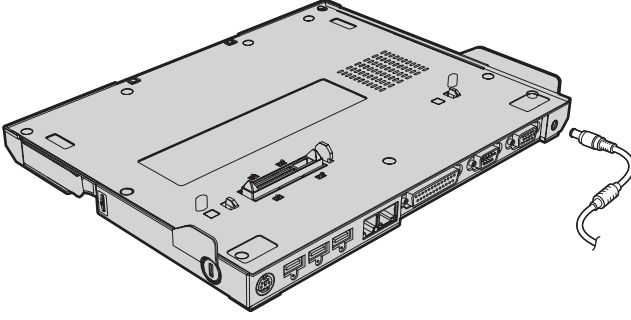

Güvenlik Vidası

Ultrabay Slim ürününü sağlam bir şekilde bağlamak için X4 UltraBase Dock ile birlikte bir vida gönderilmiştir. Bu vidayı ve bir mekanik kilidi X4 UltraBase Dock ürününün güvenlik anahtarı deliği ile kullanarak, tüm sisteminizi, hem ThinkPad X40 Series bilgisayarının, hem de X4 UltraBase Dock ürününün güvenliğini sağlayabilirsiniz. X4 UltraBase Dock ürününün güvenlik özellikleriyle ilgili ayrıntılı bilgi için bilgisayarın çevrimiçi yardım sistemi olan Access ThinkPad, olanağına başvurun.

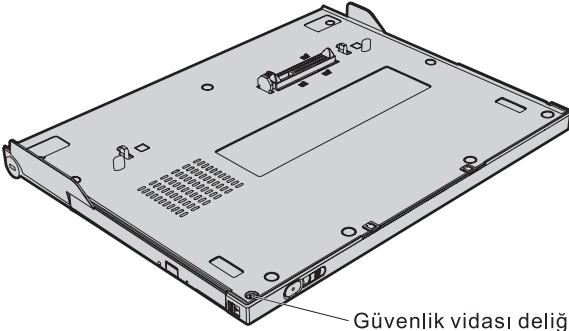

X4 UltraBase Dock ürününün kurulmasına ve kullanılmasına ilişkin ayrıntılı bilgi için Access IBM ya da bu seçenekle birlikte gönderilen Setup Poster (Kurulum Posteri) belgesine başvurun.

ThinkPad bilgisayara, aşağıdaki pil çeşitlerinden en çok iki tanesini takabilirsiniz:

- Aşağıdakilerden bir tanesi bilgisayarınıza takılır:
 - ThinkPad X40 Series 4 Hücreli Li-İyon Pil
 - ThinkPad X40 Series 8 Hücreli Li-İyon Pil
- Aşağıdakilerden bir tanesi yavaşma bağlacına bağlanır:
 - ThinkPad X40 Series Extended Life Battery
 - X4 UltraBase Dock ürününde bulunan ThinkPad Ultrabay Slim Li-İyon Pil

IBM® ThinkPad ウルトラベース X4 について

このセクションでは、ThinkPad ウルトラベース X4 の登録、取り付け、および使用方法について説明します。

製品説明

ThinkPad ウルトラベース X4 を利用できるコンピューターは、ThinkPad X40 シリーズだけです。このオプションを使用すると、ThinkPad の機能が拡張されて、ウルトラペイ・スリム・デバイスやその他のオプション・デバイスを利用できるようになります。

重要: 火災防止のため、電話線には **No.26 AWG** 以上 (太い線) を使用してください。

重要: AC アダプターには 16 VDC 3.5 A またはこれと同等の電気用品安全法に適合した物を使用してください。

取り付け

重要: ウルトラベース X4 を接続する前に、図に従って AC アダプターを接続してください。AC アダプターを ThinkPad 本体に接続した状態でウルトラベース X4 を接続すると AC アダプターを破損することがあるので、AC アダプターは ThinkPad から切り離してください。

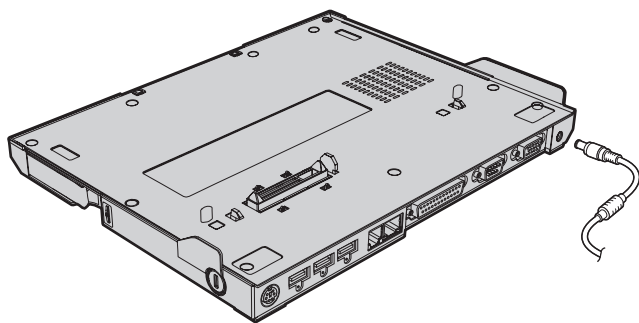

セキュリティねじ

ウルトラベース X4 には、ウルトラベイ・スリムを固定するためのねじが付属しています。このねじやウルトラベース X4 のセキュリティ・キーホールにセキュリティ・ロックを使用すると、ThinkPad X40 シリーズとウルトラベース X4 の両方を固定できます。ウルトラベース X4 のセキュリティ機能については、ThinkPad オンライン・ヘルプの「Access ThinkPad」を参照してください。

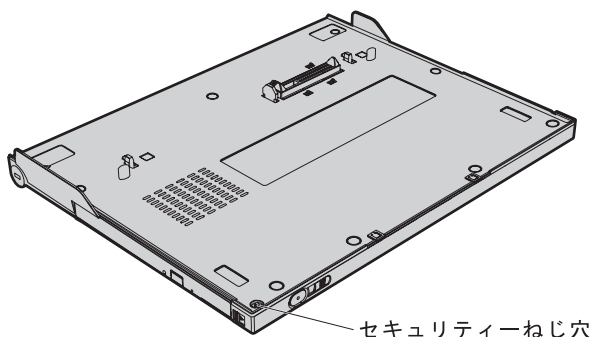

ウルトラベース X4 のセットアップおよび使用方法については、「Access IBM」またはこのオプションに付属のセットアップ・ポスターを参照してください。

ThinkPad には、次のように最大 2 つのバッテリーを取り付けることができます。

- ThinkPad に取り付け済みの次のいずれかのバッテリー。
 - ThinkPad X40 シリーズ Li-Ion バッテリー・パック
 - ThinkPad X40 シリーズ大容量 Li-Ion バッテリー・パック
- ドッキング・コネクタに付加された次のいずれかのバッテリー。
 - ThinkPad X40 シリーズ拡張 Li-Ion バッテリー・パック
 - ThinkPad ウルトラベイ・スリム Li-Ion バッテリー (ウルトラベース X4 に取り付けます)。

Appendix A. Service and Support

The following information describes the technical support that is available for your product, during the warranty period or throughout the life of the product. Refer to your IBM Statement of Limited Warranty for a full explanation of IBM warranty terms.

Online technical support

Online technical support is available during the life of your product through the Personal Computing Support Web site at:

www-3.ibm.com/pc/support/site.wss/

During the warranty period, assistance for replacement or exchange of defective components is available. In addition, if your IBM option is installed in an IBM computer, you might be entitled to service at your location. Your technical support representative can help you determine the best alternative.

Telephone technical support

Installation and configuration support through the IBM HelpCenter[®] will be withdrawn or made available for a fee, at IBM's discretion, 90 days after the option has been withdrawn from marketing. Additional support offerings, including step-by-step installation assistance, are available for a nominal fee.

To assist the technical support representative, have available as much of the following information as possible:

- Option name
- Option number
- Proof of purchase
- Computer manufacturer, model, serial number (if IBM), and manual
- Exact wording of the error message (if any)
- Description of the problem
- Hardware and software configuration information for your system

If possible, be at your computer. Your technical support representative might want to walk you through the problem during the call.

For the support telephone number and support hours by country, refer to the following table. If the number for your country or region is not listed, contact

your IBM reseller or IBM marketing representative. Response time may vary depending on the number and nature of the calls received.

Phone numbers are subject to change without notice. For the latest phone number list, go to www-3.ibm.com/pc/support/site.wss/ and click **Support Phone List**.

Country or Region	Telephone Number	Country or Region	Telephone Number
Argentina	0800-666-0011	Malaysia	03-7727-7800
Australia	1300-130-426	Mexico	001-866-434-2080
Austria	01-24592-5901	Netherlands	020-514-5770
Belgium	Dutch 02-210-9820 French 02-210-9800	New Zealand	0800-446-149
Bolivia	0800-0189	Norway	66 81 11 00
Brazil	55-11-3889-8986	Peru	0-800-50-866
Canada	1-800-565-3344 Toronto 416-383-3344	Philippines	632-995-2225
Chile	800-224-488	Portugal	21-791 51 47
China (PRC)	800-810-1818	Russia	095-940-2000
China (Hong Kong S.A.R.)	852-2825-7799	Singapore	1800-840-9911
Columbia	980-912-3021	Spain	91-662 49 16
Denmark	45 20 82 00	Sweden	08-477 4420
Ecuador	1-800-426911 (option #4)	Switzerland	058-333-09-00
Finland	09-459 69 60	Taiwan	886-2-2725-9799
France	02 38 55 74 50	Thailand	66-2-273-4000
Germany	07032-1549 201	Turkey	00-800-446-32-041
Indonesia	021-523-8535	United Kingdom	0-1475-555 055
Ireland	01-815-9202	United States	1-800-426-7378
Italy	02-7031-6101	Uruguay	000-411-005-6649
Japan	Consumer customers 0120-887-870 Business customers 0120-887-874	Venezuela	0-800-100-2011
Luxembourg	298-977 5063	Vietnam	848-8295-160

Appendix B. IBM Statement of Limited Warranty - Z125-4753-07 - 11/2002

Part 1 - General Terms

*This Statement of Limited Warranty includes Part 1 - General Terms, Part 2 - Country-unique Terms, and Part 3 - Warranty Information. The terms of Part 2 replace or modify those of Part 1. The warranties provided by IBM in this Statement of Limited Warranty apply only to Machines you purchase for your use, and not for resale. The term "Machine" means an IBM machine, its features, conversions, upgrades, elements, or accessories, or any combination of them. The term "Machine" does not include any software programs, whether pre-loaded with the Machine, installed subsequently or otherwise. **Nothing in this Statement of Limited Warranty affects any statutory rights of consumers that cannot be waived or limited by contract.***

What this Warranty Covers

IBM warrants that each Machine 1) is free from defects in materials and workmanship and 2) conforms to IBM's Official Published Specifications ("Specifications") which are available on request. The warranty period for the Machine starts on the original Date of Installation and is specified in Part 3 - Warranty Information. The date on your invoice or sales receipt is the Date of Installation unless IBM or your reseller informs you otherwise. Many features, conversions, or upgrades involve the removal of parts and their return to IBM. A part that replaces a removed part will assume the warranty service status of the removed part. Unless IBM specifies otherwise, these warranties apply only in the country or region in which you purchased the Machine.

THESE WARRANTIES ARE YOUR EXCLUSIVE WARRANTIES AND REPLACE ALL OTHER WARRANTIES OR CONDITIONS, EXPRESS OR IMPLIED, INCLUDING, BUT NOT LIMITED TO, THE IMPLIED WARRANTIES OR CONDITIONS OF MERCHANTABILITY AND FITNESS FOR A PARTICULAR PURPOSE. SOME STATES OR JURISDICTIONS DO NOT ALLOW THE EXCLUSION OF EXPRESS OR IMPLIED WARRANTIES, SO THE ABOVE EXCLUSION MAY NOT APPLY TO YOU. IN THAT EVENT, SUCH WARRANTIES ARE LIMITED IN DURATION TO THE WARRANTY PERIOD. NO WARRANTIES APPLY AFTER THAT PERIOD. SOME STATES OR JURISDICTIONS DO NOT ALLOW LIMITATIONS ON HOW LONG AN IMPLIED WARRANTY LASTS, SO THE ABOVE LIMITATION MAY NOT APPLY TO YOU.

What this Warranty Does not Cover

This warranty does not cover the following:

- any software programs, whether pre-loaded or shipped with the Machine, or installed subsequently;
- failure resulting from misuse (including but not limited to use of any Machine capacity or capability, other than that authorized by IBM in writing), accident, modification, unsuitable physical or operating environment, or improper maintenance by you;
- failure caused by a product for which IBM is not responsible; and
- any non-IBM products, including those that IBM may procure and provide with or integrate into an IBM Machine at your request.

The warranty is voided by removal or alteration of identification labels on the Machine or its parts.

IBM does not warrant uninterrupted or error-free operation of a Machine.

Any technical or other support provided for a Machine under warranty, such as assistance via telephone with "how-to" questions and those regarding Machine set-up and installation, is provided **WITHOUT WARRANTIES OF ANY KIND**.

How to Obtain Warranty Service

If the Machine does not function as warranted during the warranty period, contact IBM or your reseller to obtain warranty service. If you do not register the Machine with IBM, you may be required to present proof of purchase as evidence of your entitlement to warranty service.

What IBM Will Do to Correct Problems

When you call for service, you must follow the problem determination and resolution procedures that IBM specifies. A technician will attempt to make an initial diagnosis of your problem and help you resolve it over the telephone.

The type of warranty service applicable to your Machine is specified in Part 3 - Warranty Information.

You are responsible for downloading and installing designated Machine Code (microcode, basic input/output system code (called "BIOS"), utility programs, device drivers, and diagnostics delivered with an IBM Machine) and other software updates from an IBM Internet Web site or from other electronic media, and following the instructions that IBM provides.

If your problem can be resolved with a Customer Replaceable Unit ("CRU") (e.g., keyboard, mouse, speaker, memory, hard disk drive and other easily replaceable parts), IBM will ship these parts to you for replacement by you.

If the Machine does not function as warranted during the warranty period and your problem cannot be resolved over the telephone, through your application of Machine Code or software updates, or with a CRU, IBM or your reseller, if approved by IBM to provide warranty service, will either, at its discretion, 1) repair it to make it function as warranted, or 2) replace it with one that is at least functionally equivalent. If IBM is unable to do either, you may return the Machine to your place of purchase and your money will be refunded.

IBM or your reseller will also manage and install selected engineering changes that apply to the Machine.

Exchange of a Machine or Part

When the warranty service involves the exchange of a Machine or part, the item IBM or your reseller replaces becomes its property and the replacement becomes yours. You represent that all removed items are genuine and unaltered. The replacement may not be new, but will be in good working order and at least functionally equivalent to the item replaced. The replacement assumes the warranty service status of the replaced item.

Your Additional Responsibilities

Before IBM or your reseller exchanges a Machine or part, you agree to remove all features, parts, options, alterations, and attachments not under warranty service.

You also agree to:

1. ensure that the Machine is free of any legal obligations or restrictions that prevent its exchange;
2. obtain authorization from the owner to have IBM or your reseller service a Machine that you do not own; and
3. where applicable, before service is provided:
 - a. follow the service request procedures that IBM or your reseller provides;
 - b. backup or secure all programs, data, and funds contained in the Machine;
 - c. IBM or your reseller with sufficient, free, and safe access to your facilities to permit IBM to fulfill its obligations; and
 - d. inform IBM or your reseller of changes in the Machine's location.

4. (a) ensure all information about identified or identifiable individuals (Personal Data) is deleted from the Machine (to the extent technically possible), (b) allow IBM, your reseller or an IBM supplier to process on your behalf any remaining Personal Data as IBM or your reseller considers necessary to fulfill its obligations under this Statement of Limited Warranty (which may include shipping the Machine for such processing to other IBM service locations around the world), and (c) ensure that such processing complies with any laws applicable to such Personal Data.

Limitation of Liability

IBM is responsible for loss of, or damage to, your Machine only while it is 1) in IBM's possession or 2) in transit in those cases where IBM is responsible for the transportation charges.

Neither IBM nor your reseller are responsible for any of your confidential, proprietary or personal information contained in a Machine which you return to IBM for any reason. You should remove all such information from the Machine prior to its return.

Circumstances may arise where, because of a default on IBM's part or other liability, you are entitled to recover damages from IBM. In each such instance, regardless of the basis on which you are entitled to claim damages from IBM (including fundamental breach, negligence, misrepresentation, or other contract or tort claim), except for any liability that cannot be waived or limited by applicable laws, IBM is liable for no more than

1. damages for bodily injury (including death) and damage to real property and tangible personal property; and
2. the amount of any other actual direct damages, up to the charges (if recurring, 12 months' charges apply) for the Machine that is subject of the claim. For purposes of this item, the term "Machine" includes Machine Code and Licensed Internal Code ("LIC").

This limit also applies to IBM's suppliers and your reseller. It is the maximum for which IBM, its suppliers, and your reseller are collectively responsible.

UNDER NO CIRCUMSTANCES IS IBM, ITS SUPPLIERS OR RESELLERS LIABLE FOR ANY OF THE FOLLOWING EVEN IF INFORMED OF THEIR POSSIBILITY: 1) THIRD PARTY CLAIMS AGAINST YOU FOR DAMAGES (OTHER THAN THOSE UNDER THE FIRST ITEM LISTED ABOVE); 2) LOSS OF, OR DAMAGE TO, DATA; 3) SPECIAL, INCIDENTAL, OR INDIRECT DAMAGES OR FOR ANY ECONOMIC CONSEQUENTIAL DAMAGES; OR 4) LOST PROFITS, BUSINESS REVENUE, GOODWILL OR ANTICIPATED SAVINGS. SOME STATES OR JURISDICTIONS DO NOT ALLOW THE EXCLUSION OR LIMITATION OF INCIDENTAL OR CONSEQUENTIAL DAMAGES, SO THE ABOVE LIMITATION OR

EXCLUSION MAY NOT APPLY TO YOU. SOME STATES OR JURISDICTIONS DO NOT ALLOW LIMITATIONS ON HOW LONG AN IMPLIED WARRANTY LASTS, SO THE ABOVE LIMITATION MAY NOT APPLY TO YOU.

Governing Law

Both you and IBM consent to the application of the laws of the country in which you acquired the Machine to govern, interpret, and enforce all of your and IBM's rights, duties, and obligations arising from, or relating in any manner to, the subject matter of this Statement of Limited Warranty, without regard to conflict of law principles.

THESE WARRANTIES GIVE YOU SPECIFIC LEGAL RIGHTS AND YOU MAY ALSO HAVE OTHER RIGHTS WHICH VARY FROM STATE TO STATE OR JURISDICTION TO JURISDICTION.

Jurisdiction

All of our rights, duties, and obligations are subject to the courts of the country in which you acquired the Machine.

Part 2 - Country-unique Terms

AMERICAS

ARGENTINA

Governing Law: *The following is added after the first sentence:*

Any litigation arising from this Statement of Limited Warranty will be settled exclusively by the Ordinary Commercial Court of the city of Buenos Aires.

BRAZIL

Governing Law: *The following is added after the first sentence:*

Any litigation arising from this Statement of Limited Warranty will be settled exclusively by the court of Rio de Janeiro, RJ.

Peru

Limitation of Liability: *The following is added at the end of this section:*

In accordance with Article 1328 of the Peruvian Civil Code the limitations and exclusions specified in this section will not apply to damages caused by IBM's willful misconduct ("dolo") or gross negligence ("culpa inexcusable").

NORTH AMERICA

How to Obtain Warranty Service: *The following is added to this Section:*

To obtain warranty service from IBM in Canada or the United States, call 1-800-IBM-SERV (426-7378).

CANADA

Limitation of Liability: *The following replaces item 1 of this section:*

1. damages for bodily injury (including death) or physical harm to real property and tangible personal property caused by IBM's negligence; and

Governing Law: *The following replaces "laws of the country in which you acquired the Machine" in the first sentence:*

laws in the Province of Ontario.

UNITED STATES

Governing Law: *The following replaces "laws of the country in which you acquired the Machine" in the first sentence:*

laws of the State of New York.

ASIA PACIFIC

AUSTRALIA

What this Warranty Covers: *The following paragraph is added to this Section:*

The warranties specified in this Section are in addition to any rights you may have under the Trade Practices Act 1974 or other similar legislation and are only limited to the extent permitted by the applicable legislation.

Limitation of Liability: *The following is added to this Section:*

Where IBM is in breach of a condition or warranty implied by the Trade Practices Act 1974 or other similar legislation, IBM's liability is limited to the repair or replacement of the goods or the supply of equivalent goods. Where that condition or warranty relates to right to sell, quiet possession or clear title, or the goods are of a kind ordinarily acquired for personal, domestic or household use or consumption, then none of the limitations in this paragraph apply.

Governing Law: *The following replaces "laws of the country in which you acquired the Machine" in the first sentence:*

laws of the State or Territory.

CAMBODIA, LAOS, AND VIETNAM

Governing Law: *The following replaces "laws of the country in which you acquired the Machine" in the first sentence:*
laws of the State of New York, United States of America.

CAMBODIA, INDONESIA, LAOS, AND VIETNAM

Arbitration: *The following is added under this heading:*
Disputes arising out of or in connection with this Statement of Limited Warranty shall be finally settled by arbitration which shall be held in Singapore in accordance with the Arbitration Rules of Singapore International Arbitration Center ("SIAC Rules") then in effect. The arbitration award shall be final and binding for the parties without appeal and shall be in writing and set forth the findings of fact and the conclusions of law.

The number of arbitrators shall be three, with each side to the dispute being entitled to appoint one arbitrator. The two arbitrators appointed by the parties shall appoint a third arbitrator who shall act as chairman of the proceedings. Vacancies in the post of chairman shall be filled by the president of the SIAC. Other vacancies shall be filled by the respective nominating party. Proceedings shall continue from the stage they were at when the vacancy occurred.

If one of the parties refuses or otherwise fails to appoint an arbitrator within 30 days of the date the other party appoints its, the first appointed arbitrator shall be the sole arbitrator, provided that the arbitrator was validly and properly appointed.

All proceedings shall be conducted, including all documents presented in such proceedings, in the English language. The English language version of this Statement of Limited Warranty prevails over any other language version.

HONG KONG S.A.R. OF CHINA AND MACAU S.A.R. OF CHINA

Governing Law: *The following replaces "laws of the country in which you acquired the Machine" in the first sentence:*
laws of Hong Kong Special Administrative Region of China.

INDIA

Limitation of Liability: *The following replaces items 1 and 2 of this Section:*

1. liability for bodily injury (including death) or damage to real property and tangible personal property will be limited to that caused by IBM's negligence; and
2. as to any other actual damage arising in any situation involving nonperformance by IBM pursuant to, or in any way related to the subject of this Statement of Limited Warranty, , the charge paid by you for the

individual Machine that is the subject of the claim. For purposes of this item, the term "Machine" includes Machine Code and Licensed Internal Code ("LIC").

Arbitration: *The following is added under this heading :*

Disputes arising out of or in connection with this Statement of Limited Warranty shall be finally settled by arbitration which shall be held in Bangalore, India in accordance with the laws of India then in effect. The arbitration award shall be final and binding for the parties without appeal and shall be in writing and set forth the findings of fact and the conclusions of law.

The number of arbitrators shall be three, with each side to the dispute being entitled to appoint one arbitrator. The two arbitrators appointed by the parties shall appoint a third arbitrator who shall act as chairman of the proceedings. Vacancies in the post of chairman shall be filled by the president of the Bar Council of India. Other vacancies shall be filled by the respective nominating party. Proceedings shall continue from the stage they were at when the vacancy occurred.

If one of the parties refuses or otherwise fails to appoint an arbitrator within 30 days of the date the other party appoints its, the first appointed arbitrator shall be the sole arbitrator, provided that the arbitrator was validly and properly appointed.

All proceedings shall be conducted, including all documents presented in such proceedings, in the English language. The English language version of this Statement of Limited Warranty prevails over any other language version.

JAPAN

Governing Law: *The following sentence is added to this section:*

Any doubts concerning this Statement of Limited Warranty will be initially resolved between us in good faith and in accordance with the principle of mutual trust.

MALAYSIA

Limitation of Liability: *The word "SPECIAL" in item 3 of the fifth paragraph is deleted.*

NEW ZEALAND

What this Warranty Covers: *The following paragraph is added to this section:*

The warranties specified in this section are in addition to any rights you may have under the Consumer Guarantees Act 1993 or other legislation which

cannot be excluded or limited. The Consumer Guarantees Act 1993 will not apply in respect of any goods which IBM provides, if you require the goods for the purposes of a business as defined in that Act.

Limitation of Liability: *The following is added to this section:*

Where Machines are not acquired for the purposes of a business as defined in the Consumer Guarantees Act 1993, the limitations in this section are subject to the limitations in that Act.

PEOPLE'S REPUBLIC OF CHINA (PRC)

Governing Law: *The following replaces "laws of the country in which you acquired the Machine" in the first sentence:*

laws of the State of New York, United States of America (except when local law requires otherwise).

PHILIPPINES

Limitation of Liability: *Item 3 in the fifth paragraph is replaced by the following:*

SPECIAL (INCLUDING NOMINAL AND EXEMPLARY DAMAGES), MORAL, INCIDENTAL, OR INDIRECT DAMAGES FOR ANY ECONOMIC CONSEQUENTIAL DAMAGES; OR

Arbitration: The following is added under this heading

Disputes arising out of or in connection with this Statement of Limited Warranty shall be finally settled by arbitration which shall be held in Metro Manila, Philippines in accordance with the laws of the Philippines then in effect. The arbitration award shall be final and binding for the parties without appeal and shall be in writing and set forth the findings of fact and the conclusions of law.

The number of arbitrators shall be three, with each side to the dispute being entitled to appoint one arbitrator. The two arbitrators appointed by the parties shall appoint a third arbitrator who shall act as chairman of the proceedings. Vacancies in the post of chairman shall be filled by the president of the Philippine Dispute Resolution Center, Inc.. Other vacancies shall be filled by the respective nominating party. Proceedings shall continue from the stage they were at when the vacancy occurred.

If one of the parties refuses or otherwise fails to appoint an arbitrator within 30 days of the date the other party appoints its, the first appointed arbitrator shall be the sole arbitrator, provided that the arbitrator was validly and properly appointed.

All proceedings shall be conducted, including all documents presented in such proceedings, in the English language. The English language version of this Statement of Limited Warranty prevails over any other language version.

SINGAPORE

Limitation of Liability: The words "SPECIAL" and "ECONOMIC" in item 3 in the fifth paragraph are deleted.

EUROPE, MIDDLE EAST, AFRICA (EMEA)

THE FOLLOWING TERMS APPLY TO ALL EMEA COUNTRIES:

The terms of this Statement of Limited Warranty apply to Machines purchased from IBM or an IBM reseller.

Hot to Obtain Warranty Service: If you purchase a Machine in Austria, Belgium, Cyprus, Denmark, Estonia, Finland, France, Germany, Greece, Iceland, Ireland, Italy, Latvia, Liechtenstein, Lithuania, Luxembourg, Monaco, Netherlands, Norway, Portugal, Spain, San Marino, Sweden, Switzerland, United Kingdom or Vatican State, you may obtain warranty service for that Machine in any of those countries from either (1) an IBM reseller approved to perform warranty service or (2) from IBM, provided the Machine has been announced and made available by IBM in the country in which you wish to obtain service. If you purchased a Personal Computer Machine in Albania, Armenia, Belarus, Bosnia and Herzegovina, Bulgaria, Croatia, Czech Republic, Georgia, Hungary, Kazakhstan, Kyrgyzstan, Federal Republic of Yugoslavia, Former Yugoslav Republic of Macedonia (FYROM), Moldova, Poland, Romania, Russia, Slovak Republic, Slovenia, or Ukraine, you may obtain warranty service for that Machine in any of those countries from either (1) an IBM reseller approved to perform warranty service or (2) from IBM.

If you purchase a Machine in a Middle Eastern or African country, you may obtain warranty service for that Machine from the IBM entity within the country of purchase, if that IBM entity provides warranty service in that country, or from an IBM reseller, approved by IBM to perform warranty service on that Machine in that country. Warranty service in Africa is available within 50 kilometers of an IBM approved service provider. You are responsible for transportation costs for Machines located outside 50 kilometers of an IBM approved service provider.

*Add the following paragraph in **Western Europe** (Austria, Belgium, Cyprus, Denmark, Finland, France, Germany, Greece, Iceland, Ireland, Italy, Liechtenstein, Luxembourg, Monaco, Netherlands, Norway, Portugal, Spain, San Marino, Sweden, Switzerland, United Kingdom, Vatican State):*

The warranty for Machines acquired in Western Europe shall be valid and applicable in all Western Europe countries provided the Machines have been announced and made available in such countries.

Governing Law:

The phrase "the laws of the country in which you acquired the Machine" is replaced by:

1) "the laws of Austria" in **Albania, Armenia, Azerbaijan, Belarus, Bosnia-Herzegovina, Bulgaria, Croatia, Georgia, Hungary, Kazakhstan, Kyrgyzstan, FYR Macedonia, Moldova, Poland, Romania, Russia, Slovakia, Slovenia, Tajikistan, Turkmenistan, Ukraine, Uzbekistan, and FR Yugoslavia;** 2) "the laws of France" in **Algeria, Benin, Burkina Faso, Cameroon, Cape Verde, Central African Republic, Chad, Comoros, Congo Republic, Djibouti, Democratic Republic of Congo, Equatorial Guinea, French Guiana, French Polynesia, Gabon, Gambia, Guinea, Guinea-Bissau, Ivory Coast, Lebanon, Madagascar, Mali, Mauritania, Mauritius, Mayotte, Morocco, New Caledonia, Niger, Reunion, Senegal, Seychelles, Togo, Tunisia, Vanuatu, and Wallis & Futuna;** 3) "the laws of Finland" in **Estonia, Latvia, and Lithuania;** 4) "the laws of England" in **Angola, Bahrain, Botswana, Burundi, Egypt, Eritrea, Ethiopia, Ghana, Jordan, Kenya, Kuwait, Liberia, Malawi, Malta, Mozambique, Nigeria, Oman, Pakistan, Qatar, Rwanda, Sao Tome, Saudi Arabia, Sierra Leone, Somalia, Tanzania, Uganda, United Arab Emirates, the United Kingdom, West Bank/Gaza, Yemen, Zambia, and Zimbabwe;** and 5) "the laws of South Africa" in **South Africa, Namibia, Lesotho and Swaziland.**

Jurisdiction: *The following exceptions are added to this section:*

1) In **Austria** the choice of jurisdiction for all disputes arising out of this Statement of Limited Warranty and relating thereto, including its existence, will be the competent court of law in Vienna, Austria (Inner-City); 2) in **Angola, Bahrain, Botswana, Burundi, Egypt, Eritrea, Ethiopia, Ghana, Jordan, Kenya, Kuwait, Liberia, Malawi, Malta, Mozambique, Nigeria, Oman, Pakistan, Qatar, Rwanda, Sao Tome, Saudi Arabia, Sierra Leone, Somalia, Tanzania, Uganda, United Arab Emirates, West Bank/Gaza, Yemen, Zambia, and Zimbabwe** all disputes arising out of this Statement of Limited Warranty or related to its execution, including summary proceedings, will be submitted to the exclusive jurisdiction of the English courts; 3) in **Belgium** and **Luxembourg**, all disputes arising out of this Statement of Limited Warranty or related to its interpretation or its execution, the law, and the courts of the capital city, of the country of your registered office and/or commercial site location only are competent; 4) in **France, Algeria, Benin, Burkina Faso, Cameroon, Cape Verde, Central African Republic, Chad, Comoros, Congo Republic, Djibouti, Democratic Republic of Congo, Equatorial Guinea, French Guiana, French Polynesia, Gabon, Gambia, Guinea, Guinea-Bissau,**

Ivory Coast, Lebanon, Madagascar, Mali, Mauritania, Mauritius, Mayotte, Morocco, New Caledonia, Niger, Reunion, Senegal, Seychelles, Togo, Tunisia, Vanuatu, and Wallis & Futuna all disputes arising out of this Statement of Limited Warranty or related to its violation or execution, including summary proceedings, will be settled exclusively by the Commercial Court of Paris; 5) in **Russia**, all disputes arising out of or in relation to the interpretation, the violation, the termination, the nullity of the execution of this Statement of Limited Warranty shall be settled by Arbitration Court of Moscow; 6) in **South Africa, Namibia, Lesotho and Swaziland**, both of us agree to submit all disputes relating to this Statement of Limited Warranty to the jurisdiction of the High Court in Johannesburg; 7) in **Turkey** all disputes arising out of or in connection with this Statement of Limited Warranty shall be resolved by the Istanbul Central (Sultanahmet) Courts and Execution Directorates of Istanbul, the Republic of Turkey; 8) in each of the following specified countries, any legal claim arising out of this Statement of Limited Warranty will be brought before, and settled exclusively by, the competent court of a) Athens for **Greece**, b) Tel Aviv-Jaffa for **Israel**, c) Milan for **Italy**, d) Lisbon for **Portugal**, and e) Madrid for **Spain**; and 9) in the **United Kingdom**, both of us agree to submit all disputes relating to this Statement of Limited Warranty to the jurisdiction of the English courts.

Arbitration: *The following is added under this heading:*

In Albania, Armenia, Azerbaijan, Belarus, Bosnia-Herzegovina, Bulgaria, Croatia, Georgia, Hungary, Kazakhstan, Kyrgyzstan, FYR Macedonia, Moldova, Poland, Romania, Russia, Slovakia, Slovenia, Tajikistan, Turkmenistan, Ukraine, Uzbekistan, and FR Yugoslavia all disputes arising out of this Statement of Limited Warranty or related to its violation, termination or nullity will be finally settled under the Rules of Arbitration and Conciliation of the International Arbitral Center of the Federal Economic Chamber in Vienna (Vienna Rules) by three arbitrators appointed in accordance with these rules. The arbitration will be held in Vienna, Austria, and the official language of the proceedings will be English. The decision of the arbitrators will be final and binding upon both parties. Therefore, pursuant to paragraph 598 (2) of the Austrian Code of Civil Procedure, the parties expressly waive the application of paragraph 595 (1) figure 7 of the Code. IBM may, however, institute proceedings in a competent court in the country of installation.

In Estonia, Latvia and Lithuania all disputes arising in connection with this Statement of Limited Warranty will be finally settled in arbitration that will be held in Helsinki, Finland in accordance with the arbitration laws of Finland then in effect. Each party will appoint one arbitrator. The arbitrators will then jointly appoint the chairman. If arbitrators cannot agree on the chairman, then the Central Chamber of Commerce in Helsinki will appoint the chairman.

EUROPEAN UNION (EU)

THE FOLLOWING TERMS APPLY TO ALL EU COUNTRIES:

Consumers have legal rights under applicable national legislation governing the sale of consumer goods. Such rights are not affected by the warranties provided in this Statement of Limited Warranty.

How to Obtain Warranty Service: *The following is added to this section:*

To obtain warranty service from IBM in EU countries, see the telephone listing in Part 3 - Warranty Information.

You may contact IBM at the following address:

IBM Warranty & Service Quality Dept.

PO Box 30

Spango Valley

Greenock

Scotland PA 16 OAH

AUSTRIA, DENMARK, FINLAND, GREECE, ITALY, NETHERLANDS, PORTUGAL, SPAIN, SWEDEN AND SWITZERLAND

Limitation of Liability: *The following replaces the terms of this section in its entirety:*

Except as otherwise provided by mandatory law:

1. IBM's liability for any damages and losses that may arise as a consequence of the fulfillment of its obligations under or in connection with this Statement of Limited Warranty or due to any other cause related to this Statement of Limited Warranty is limited to the compensation of only those damages and losses proved and actually arising as an immediate and direct consequence of the non-fulfillment of such obligations (if IBM is at fault) or of such cause, for a maximum amount equal to the charges you paid for the Machine. For purposes of this item, the term "Machine" includes Machine Code and Licensed Internal Code ("LIC").

The above limitation shall not apply to damages for bodily injuries (including death) and damages to real property and tangible personal property for which IBM is legally liable.

2. **UNDER NO CIRCUMSTANCES IS IBM, ITS SUPPLIERS OR RESELLERS LIABLE FOR ANY OF THE FOLLOWING, EVEN IF INFORMED OF THEIR POSSIBILITY: 1) LOSS OF, OR DAMAGE TO,**

DATA; 2) INCIDENTAL OR INDIRECT DAMAGES, OR FOR ANY ECONOMIC CONSEQUENTIAL DAMAGES; 3) LOST PROFITS, EVEN IF THEY ARISE AS AN IMMEDIATE CONSEQUENCE OF THE EVENT THAT GENERATED THE DAMAGES; OR 4) LOSS OF BUSINESS, REVENUE, GOODWILL, OR ANTICIPATED SAVINGS.

FRANCE AND BELGIUM

Limitation of Liability: *The following replaces the terms of this section in its entirety:*

Except as otherwise provided by mandatory law:

1. IBM's liability for any damages and losses that may arise as a consequence of the fulfillment of its obligations under or in connection with this Statement of Limited Warranty is limited to the compensation of only those damages and losses proved and actually arising as an immediate and direct consequence of the non-fulfillment of such obligations (if IBM is at fault), for a maximum amount equal to the charges you paid for the Machine that has caused the damages. For purposes of this item, the term "Machine" includes Machine Code and Licensed Internal Code ("LIC").

The above limitation shall not apply to damages for bodily injuries (including death) and damages to real property and tangible personal property for which IBM is legally liable.

2. **UNDER NO CIRCUMSTANCES IS IBM, ITS SUPPLIERS OR RESELLERS LIABLE FOR ANY OF THE FOLLOWING, EVEN IF INFORMED OF THEIR POSSIBILITY: 1) LOSS OF, OR DAMAGE TO, DATA; 2) INCIDENTAL OR INDIRECT DAMAGES, OR FOR ANY ECONOMIC CONSEQUENTIAL DAMAGES; 3) LOST PROFITS, EVEN IF THEY ARISE AS AN IMMEDIATE CONSEQUENCE OF THE EVENT THAT GENERATED THE DAMAGES; OR 4) LOSS OF BUSINESS, REVENUE, GOODWILL, OR ANTICIPATED SAVINGS.**

THE FOLLOWING TERMS APPLY TO THE COUNTRY SPECIFIED:

AUSTRIA

What this Warranty Covers: *The following replaces the first sentence of the first paragraph of this section:*

The warranty for an IBM Machine covers the functionality of the Machine for its normal use and the Machine's conformity to its Specifications.

The following paragraphs are added to this Section:

The minimum warranty period for Machines is 12 months from the date of delivery. . The limitation period for consumers in action for breach of warranty

is the statutory period as a minimum. In case IBM or your reseller is unable to repair an IBM Machine, you can alternatively ask for a partial refund as far as justified by the reduced value of the unrepaired Machine or ask for a cancellation of the respective agreement for such Machine and get your money refunded.

The second paragraph does not apply.

What IBM Will Do to Correct Problems: *The following is added to this section:*

During the warranty period, transportation for delivery of the failing Machine to IBM will be at IBM's expense.

Limitation of Liability: *The following paragraph is added to this section:*

The limitations and exclusions specified in the Statement of Limited Warranty will not apply to damages caused by IBM with fraud or gross negligence and for express warranty.

The following sentence is added to the end of item 2:

IBM's liability under this item is limited to the violation of essential contractual terms in cases of ordinary negligence.

EGYPT

Limitation of Liability: *The following replaces item 2 in this section:*

as to any other actual direct damages, IBM's liability will be limited to the total amount you paid for the Machine that is the subject of the claim. For purposes of this item, the term "Machine" includes Machine Code and Licensed Internal Code (LIC).

Applicability of suppliers and resellers (unchanged).

FRANCE

Limitation of Liability: *The following replaces the second sentence of the first paragraph of this section:*

In such instances, regardless of the basis on which you are entitled to claim damages from IBM, IBM is liable for no more than: *(items 1 and 2 unchanged).*

GERMANY

What this Warranty Covers: *The following replaces the first sentence of the first paragraph of this section:*

The warranty for an IBM Machine covers the functionality of the Machine for its normal use and the Machine's conformity to its Specifications.

The following paragraphs are added to this section:

The minimum warranty period for Machines is twelve months. In case IBM or your reseller is unable to repair an IBM Machine, you can alternatively ask for a partial refund as far as justified by the reduced value of the unrepaired Machine or ask for a cancellation of the respective agreement for such Machine and get your money refunded.

The second paragraph does not apply.

What IBM Will Do to Correct Problems: *The following is added to this section:*

During the warranty period, transportation for delivery of the failing Machine to IBM will be at IBM's expense.

Limitation of Liability: *The following paragraph is added to this section:*

The limitations and exclusions specified in the Statement of Limited Warranty will not apply to damages caused by IBM with fraud or gross negligence and for express warranty.

The following sentence is added to the end of item 2:

IBM's liability under this item is limited to the violation of essential contractual terms in cases of ordinary negligence.

HUNGARY

Limitation of Liability: *The following is added at the end of this section:*

The limitation and exclusion specified herein shall not apply to liability for a breach of contract damaging life, physical well-being, or health that has been caused intentionally, by gross negligence, or by a criminal act.

The parties accept the limitations of liability as valid provisions and state that the Section 314.(2) of the Hungarian Civil Code applies as the acquisition price as well as other advantages arising out of the present Statement of Limited Warranty balance this limitation of liability.

IRELAND

What this Warranty Covers: *The following is added to this section:*

Except as expressly provided in these terms and conditions, all statutory

conditions, including all warranties implied, but without prejudice to the generality of the foregoing all warranties implied by the Sale of Goods Act 1893 or the Sale of Goods and Supply of Services Act 1980 are hereby excluded.

Limitation of Liability: *The following replaces the terms of this section in its entirety:*

For the purposes of this section, a "Default" means any act, statement, omission, or negligence on the part of IBM in connection with, or in relation to, the subject matter of this Statement of Limited Warranty in respect of which IBM is legally liable to you, whether in contract or tort. A number of Defaults which together result in, or contribute to, substantially the same loss or damage will be treated as one Default occurring on the date of occurrence of the last such Default.

Circumstances may arise where, because of a Default, you are entitled to recover damages from IBM.

This section sets out the extent of IBM's liability and your sole remedy.

1. IBM will accept unlimited liability for death or personal injury caused by the negligence of IBM.
2. Subject always to the Items for Which IBM is Not Liable below, IBM will accept unlimited liability for physical damage to your tangible property resulting from the negligence of IBM.
3. Except as provided in items 1 and 2 above, IBM's entire liability for actual damages for any one Default will not in any event exceed the greater of 1) EUR 125,000, or 2) 125% of the amount you paid for the Machine directly relating to the Default.

Items for Which IBM is Not Liable

Save with respect to any liability referred to in item 1 above, under no circumstances is IBM, its suppliers or resellers liable for any of the following, even if IBM or they were informed of the possibility of such losses:

1. loss of, or damage to, data;
2. special, indirect, or consequential loss; or
3. loss of profits, business, revenue, goodwill, or anticipated savings.

SLOVAKIA

Limitation of Liability: *The following is added to the end of the last paragraph:*

The limitations apply to the extent they are not prohibited under §§ 373-386 of the Slovak Commercial Code.

SOUTH AFRICA, NAMIBIA, BOTSWANA, LESOTHO AND SWAZILAND

Limitation of Liability: *The following is added to this section:*

IBM's entire liability to you for actual damages arising in all situations involving nonperformance by IBM in respect of the subject matter of this Statement of Warranty will be limited to the charge paid by you for the individual Machine that is the subject of your claim from IBM.

UNITED KINGDOM

Limitation of Liability: *The following replaces the terms of this section in its entirety:*

For the purposes of this section, a "Default" means any act, statement, omission, or negligence on the part of IBM in connection with, or in relation to, the subject matter of this Statement of Limited Warranty in respect of which IBM is legally liable to you, whether in contract or tort. A number of Defaults which together result in, or contribute to, substantially the same loss or damage will be treated as one Default.

Circumstances may arise where, because of a Default, you are entitled to recover damages from IBM.

This section sets out the extent of IBM's liability and your sole remedy.

1. IBM will accept unlimited liability for:
 - a. death or personal injury caused by the negligence of IBM; and
 - b. any breach of its obligations implied by Section 12 of the Sale of Goods Act 1979 or Section 2 of the Supply of Goods and Services Act 1982, or any statutory modification or re-enactment of either such Section.
2. IBM will accept unlimited liability, subject always to the Items for Which IBM is Not Liable below, for physical damage to your tangible property resulting from the negligence of IBM.
3. IBM's entire liability for actual damages for any one Default will not in any event, except as provided in items 1 and 2 above, exceed the greater of 1) Pounds Sterling 75,000, or 2) 125% of the total purchase price payable or the charges for the Machine directly relating to the Default.

These limits also apply to IBM's suppliers and resellers. They state the maximum for which IBM and such suppliers and resellers are collectively responsible.

Items for Which IBM is Not Liable

Save with respect to any liability referred to in item 1 above, under no circumstances is IBM or any of its suppliers or resellers liable for any of the following, even if IBM or they were informed of the possibility of such losses:

1. loss of, or damage to, data;
2. special, indirect, or consequential loss; or
3. loss of profits, business, revenue, goodwill, or anticipated savings.

Part 3 - Warranty Information

This Part 3 provides information regarding the warranty applicable to your Machine, including the warranty period and type of warranty service IBM provides.

Warranty Period

The warranty period may vary by country or region and is specified in the table below. NOTE: "Region" means either Hong Kong or Macau Special Administrative Region of China.

ThinkPad X4 UltraBase Dock

Country or Region of Purchase	Warranty Period	Type of Warranty Service
Worldwide	3 years	1 and 4

A warranty period of 3 years on parts and 3 years on labor means that IBM provides warranty service without charge for parts and labor during the 3 year warranty period.

Types of Warranty Service

If required, IBM provides repair or exchange service depending on the type of warranty service specified for your Machine in the above table and as described below. Warranty service may be provided by your reseller if approved by IBM to perform warranty service. Scheduling of service will depend upon the time of your call and is subject to parts availability. Service levels are response time objectives and are not guaranteed. The specified level of warranty service may not be available in all worldwide locations, additional charges may apply outside IBM's normal service area, contact your local IBM representative or your reseller for country and location specific information.

1. Customer Replaceable Unit ("CRU") Service

IBM will ship CRU parts to you for your replacement. If IBM instructs you to return the replaced CRU, you are responsible for returning it to IBM in accordance with IBM's instructions. If you do not return the defective CRU, if IBM so instructs, within 30 days of your receipt of the replacement CRU, IBM may charge you for the replacement.

2. On-site Service

IBM or your reseller will either repair or exchange the failing Machine at your location and verify its operation. You must provide suitable working area to allow disassembly and reassembly of the IBM Machine. The area must be clean, well lit and suitable for the purpose. **For some Machines, certain repairs may require sending the Machine to an IBM service center.**

3. Courier or Depot Service¹

You will disconnect the failing Machine for collection arranged by IBM. IBM will provide you with a shipping container for you to return your Machine to a designated service center. A courier will pick up your Machine and deliver it to the designated service center. Following its repair or exchange, IBM will arrange the return delivery of the Machine to your location. You are responsible for its installation and verification.

4. Customer Carry-In or Mail-In Service

You will deliver or mail as IBM specifies (prepaid unless IBM specifies otherwise) the failing Machine suitably packaged to a location IBM designates. After IBM has repaired or exchanged the Machine, IBM will make it available for your collection or, for Mail-in Service, IBM will return it to you at IBM's expense, unless IBM specifies otherwise. You are responsible for the subsequent installation and verification of the Machine.

The IBM Machine Warranty worldwide web site at http://www.ibm.com/servers/support/machine_warranties/ provides a worldwide overview of IBM's Limited Warranty for Machines, a Glossary of IBM definitions, Frequently Asked Questions (FAQs) and Support by Product (Machine) with links to Product Support pages. **The IBM Statement of Limited Warranty is also available on this site in 29 languages.**

To obtain warranty service contact IBM or your IBM reseller. In Canada or the United States, call 1-800-IBM-SERV (426-7378). For other countries, see the telephone numbers below.

1. This type of service is called ThinkPad EasyServ or EasyServ in some countries.

Phone numbers are subject to change without notice. For the latest phone number list, go to www-3.ibm.com/pc/support/site.wss/ and click **Support Phone List**.

Country or Region	Telephone Number	Country or Region	Telephone Number
Argentina	0800-666-0011	Malaysia	03-7727-7800
Australia	1300-130-426	Mexico	001-866-434-2080
Austria	01-24592-5901	Netherlands	020-514-5770
Belgium	Dutch 02-210-9820 French 02-210-9800	New Zealand	0800-446-149
Bolivia	0800-0189	Norway	66 81 11 00
Brazil	55-11-3889-8986	Peru	0-800-50-866
Canada	1-800-565-3344 Toronto 416-383-3344	Philippines	632-995-2225
Chile	800-224-488	Portugal	21-791 51 47
China (PRC)	800-810-1818	Russia	095-940-2000
China (Hong Kong S.A.R.)	852-2825-7799	Singapore	1800-840-9911
Columbia	980-912-3021	Spain	91-662 49 16
Denmark	45 20 82 00	Sweden	08-477 4420
Ecuador	1-800-426911 (option #4)	Switzerland	058-333-09-00
Finland	09-459 69 60	Taiwan	886-2-2725-9799
France	02 38 55 74 50	Thailand	66-2-273-4000
Germany	07032-1549 201	Turkey	00-800-446-32-041
Indonesia	021-523-8535	United Kingdom	0-1475-555 055
Ireland	01-815-9202	United States	1-800-426-7378
Italy	02-7031-6101	Uruguay	000-411-005-6649
Japan	Consumer customers 0120-887-870 Business customers 0120-887-874	Venezuela	0-800-100-2011
Luxembourg	298-977 5063	Vietnam	848-8295-160

Appendix C. Notices

IBM may not offer the products, services, or features discussed in this document in all countries. Consult your local IBM representative for information on the products and services currently available in your area. Any reference to an IBM product, program, or service is not intended to state or imply that only that IBM product, program, or service may be used. Any functionally equivalent product, program, or service that does not infringe any IBM intellectual property right may be used instead. However, it is the user's responsibility to evaluate and verify the operation of any non-IBM product, program, or service.

IBM may have patents or pending patent applications covering subject matter described in this document. The furnishing of this document does not give you any license to these patents. You can send license inquiries, in writing, to:

*IBM Director of Licensing
IBM Corporation
North Castle Drive
Armonk, NY 10504-1785
U.S.A.*

INTERNATIONAL BUSINESS MACHINES CORPORATION PROVIDES THIS PUBLICATION "AS IS" WITHOUT WARRANTY OF ANY KIND, EITHER EXPRESS OR IMPLIED, INCLUDING, BUT NOT LIMITED TO, THE IMPLIED WARRANTIES OF NON-INFRINGEMENT, MERCHANTABILITY OR FITNESS FOR A PARTICULAR PURPOSE. Some jurisdictions do not allow disclaimer of express or implied warranties in certain transactions, therefore, this statement may not apply to you.

This information could include technical inaccuracies or typographical errors. Changes are periodically made to the information herein; these changes will be incorporated in new editions of the publication. IBM may make improvements and/or changes in the product(s) and/or the program(s) described in this publication at any time without notice.

The products described in this document are not intended for use in implantation or other life support applications where malfunction may result in injury or death to persons. The information contained in this document does not affect or change IBM product specifications or warranties. Nothing in this document shall operate as an express or implied license or indemnity under the intellectual property rights of IBM or third parties. All information contained in this document was obtained in specific environments and is presented as an illustration. The result obtained in other operating environments may vary.

IBM may use or distribute any of the information you supply in any way it believes appropriate without incurring any obligation to you.

Any references in this publication to non-IBM Web sites are provided for convenience only and do not in any manner serve as an endorsement of those Web sites. The materials at those Web sites are not part of the materials for this IBM product, and use of those Web sites is at your own risk.

Any performance data contained herein was determined in a controlled environment. Therefore, the result obtained in other operating environments may vary significantly. Some measurements may have been made on development-level systems and there is no guarantee that these measurements will be the same on generally available systems. Furthermore, some measurements may have been estimated through extrapolation. Actual results may vary. Users of this document should verify the applicable data for their specific environment.

Federal Communications Commission (FCC) statement

Note: This equipment has been tested and found to comply with the limits for a Class B digital device, pursuant to Part 15 of the FCC Rules. These limits are designed to provide reasonable protection against harmful interference in a residential installation. This equipment generates, uses, and can radiate radio frequency energy and, if not installed and used in accordance with the instructions, may cause harmful interference to radio communications. However, there is no guarantee that interference will not occur in a particular installation. If this equipment does cause harmful interference to radio or television reception, which can be determined by turning the equipment off and on, the user is encouraged to try to correct the interference by one or more of the following measures:

- Reorient or relocate the receiving antenna.
- Increase the separation between the equipment and receiver.
- Connect the equipment into an outlet on a circuit different from that to which the receiver is connected.
- Consult an IBM authorized dealer or service representative for help.

Properly shielded and grounded cables and connectors must be used in order to meet FCC emission limits. Proper cables and connectors are available from IBM authorized dealers. IBM is not responsible for any radio or television interference caused by using other than recommended cables and connectors or by unauthorized changes or modifications to this equipment. Unauthorized changes or modifications could void the user's authority to operate the equipment.

This device complies with Part 15 of the FCC Rules. Operation is subject to the following two conditions: (1) this device may not cause harmful interference, and (2) this device must accept any interference received, including interference that may cause undesired operation.

Responsible party:

International Business Machines Corporation
New Orchard Road
Armonk, NY 10504
Telephone: 1-919-543-2193



**Tested To Comply
With FCC Standards**

FOR HOME OR OFFICE USE

Industry Canada Class B emission compliance statement

This Class B digital apparatus complies with Canadian ICES-003.

Avis de conformité a la réglementation d'Industrie Canada

Cet appareil numérique de la classe B est conforme à la norme NMB-003 du Canada.

Deutsche EMV-Direktive (electromagnetische Verträglichkeit)

Zulassungsbeseinigunglaut dem Deutschen Gesetz über die elektromagnetische Verträglichkeit von Geräten (EMVG) vom 30. August 1995 (bzw. der EMC EG Richtlinie 89/336):

Dieses Gerät ist berechtigt in Übereinstimmungmit dem Deutschen EMVG das EG-Konformitätszeichen - CE - zu führen. Verantwortlich für die Konformitätserklärung nach Paragraph 5 des EMVG ist die:

IBM Deutschland Informationssysteme GmbH, 70548 Stuttgart.

Informationen in Hinsicht EMVG Paragraph 3 Abs. (2) 2:

Das Gerät erfüllt die Schutzanforderungen nach EN 55024:1998 und EN 55022:1998 Klasse B.
--

EN 55022 Hinweis:

“Wird dieses Gerät in einer industriellen Umgebung betrieben (wie in EN 55022:B festgelegt), dann kann es dabei eventuell gestört werden. In solch einem FA11 ist der Abstand bzw. die Abschirmung zu der industriellen Störquelle zu vergrößern.”

Anmerkung:

Um die Einhaltung des EMVG sicherzustellen sind die Geräte, wie in den IBM Handbüchern angegeben, zu installieren und zu betreiben.

European Union - emission directive

This product is in conformity with the protection requirements of EU Council Directive 89/336/ECC on the approximation of the laws of the Member States relating to electromagnetic compatibility.

IBM cannot accept responsibility for any failure to satisfy the protection requirements resulting from a non-recommended modification of the product, including the fitting of non-IBM option cards.

This product has been tested and found to comply with the limits for Class B Information Technology Equipment according to European Standard EN 55022. The limits for Class B equipment were derived for typical residential environments to provide reasonable protection against interference with licensed communication devices.

Union Européenne - Directive Conformité électromagnétique

Ce produit est conforme aux exigences de protection de la Directive 89/336/EEC du Conseil de l'UE sur le rapprochement des lois des États membres en matière de compatibilité électromagnétique.

IBM ne peut accepter aucune responsabilité pour le manquement aux exigences de protection résultant d'une modification non recommandée du produit, y compris l'installation de cartes autres que les cartes IBM.

Ce produit a été testé et il satisfait les conditions de l'équipement informatique de Classe B en vertu de Standard européen EN 55022. Les conditions pour l'équipement de Classe B ont été définies en fonction d'un contexte résidentiel ordinaire afin de fournir une protection raisonnable contre l'interférence d'appareils de communication autorisés.

Unione Europea - Directiva EMC (Conformidad electromagnética)

Este producto satisface los requisitos de protección del Consejo de la UE, Directiva 89/336/CEE en lo que a la legislatura de los Estados Miembros sobre compatibilidad electromagnética se refiere.

IBM no puede aceptar responsabilidad alguna si este producto deja de satisfacer dichos requisitos de protección como resultado de una modificación no recomendada del producto, incluyendo el ajuste de tarjetas de opción que no sean IBM.

Este producto ha sido probado y satisface los límites para Equipos Informáticos Clase B de conformidad con el Estándar Europeo EN 55022. Los límites para los equipos de Clase B se han establecido para entornos residenciales típicos a fin de proporcionar una protección razonable contra las interferencias con dispositivos de comunicación licenciados.

Union Europea - Normativa EMC

Questo prodotto è conforme alle normative di protezione ai sensi della Direttiva del Consiglio dell'Unione Europea 89/336/CEE sull'armonizzazione legislativa degli stati membri in materia di compatibilità elettromagnetica.

IBM non accetta responsabilità alcuna per la mancata conformità alle normative di protezione dovuta a modifiche non consigliate al prodotto, compresa l'installazione di schede e componenti di marca diversa da IBM.

Le prove effettuate sul presente prodotto hanno accertato che esso rientra nei limiti stabiliti per le apparecchiature di informatica Classe B ai sensi della Norma Europea EN 55022. I limiti delle apparecchiature della Classe B sono stati stabiliti al fine di fornire ragionevole protezione da interferenze mediante dispositivi di comunicazione in concessione in ambienti residenziali tipici.

이 기기는 가정용으로 전자파 적합등록을 한 기기로서
주거지역에서는 물론 모든 지역에서 사용할 수 있습니다.

この装置は、情報処理装置等電波障害自主規制協議会（VCCI）の基準に基づくクラスB情報技術装置です。この装置は、家庭環境で使用することを目的としていますが、この装置がラジオやテレビジョン受信機に近接して使用されると、受信障害を引き起こすことがあります。
取扱説明書に従って正しい取り扱いをして下さい。

Japanese statement of compliance for products less than or equal to 20 A per phase

高調波ガイドライン適合品

Trademarks

The following terms are trademarks of International Business Machines Corporation in the United States, other countries, or both:

HelpCenter

IBM

IBM logo

ThinkPad

UltraBase

Ultrabay

Other company, product, or service names may be trademarks or service marks of others.



Part Number: 22P9193

(1P) P/N: 22P9193

