

TotalStorage DS300 and DS400



Dual Controller Software Installation Guide

TotalStorage DS300 and DS400



Dual Controller Software Installation Guide

Note: Before using this information and the product it supports, read the general information in Appendix B, "Notices," on page 33.

Fourth Edition (June 2005)

© Copyright International Business Machines Corporation 2004, 2005. All rights reserved.

US Government Users Restricted Rights – Use, duplication or disclosure restricted by GSA ADP Schedule Contract with IBM Corp.

Contents

Chapter 1. Installing and running ServeRAID Manager	1
System Requirements	1
Management station system requirements	1
Client computer system requirements	1
Updating the registry information for the host computer	2
Installing the ServeRAID Manager program	2
Getting started	3
Running ServeRAID Manager	3
Adding a management station agent	3
Removing a management station agent	4
Adding the storage subsystem to the management station	4
Navigating ServeRAID Manager	4
Physical devices view	5
Logical devices view	6
Changing how drives are displayed	6
Viewing related components	6
Finding more information	7
Chapter 2. Installing firmware	9
Downloading firmware	9
Updating the firmware	9
Restarting the controller	9
Chapter 3. Configuring a new controller	11
Getting started	11
Completing the controller configuration	13
Chapter 4. Installing a DS300 or DS400 storage subsystem in a Windows cluster server environment	15
Preinstallation tasks for an iSCSI (DS300) environment	15
iSCSI configuration considerations	15
Installing the Microsoft iSCSI Software Initiator	16
Preinstallation tasks for a Fibre Channel (DS400) environment	16
Fibre Channel configuration considerations	16
Installing the Fibre Channel host adapters	17
Installing the multi-path I/O DSM software	18
Installing a DS300 or DS400 storage subsystem in a cluster environment	18
Windows 2000	18
Windows Server 2003	19
Installing the cluster server software	20
Windows 2000	20
Windows Server 2003	21
Upgrading from a previous version of the storage management software	21
Performing a scheduled upgrade	21
Performing a rolling upgrade	23
Windows 2000	23
Windows Server 2003	24
Upgrading from Windows 2000 Advanced Server to Windows Server 2003 in a cluster configuration	25
Appendix A. Using the FlashCopy Management Command Line Tool	27
Introduction	27
Flashcopy Management Command Line Tool glossary	27

Command line syntax and output	28
Return values	28
Output	28
Commands	28
list_agents	28
list_server_instances	29
list_instance_databases	29
take_snapshot	29
schedule_snapshot	30
list_scheduled	31
unschedule_snapshot	31
roll_back	31
delete_snapshot	31
list_snapshots	32
help	32
Appendix B. Notices	33
Edition notice	33
Trademarks	34
Index	35

Chapter 1. Installing and running ServeRAID Manager

This chapter provides installation instructions for the IBM® ServeRAID™ Manager program, and provides an overview of the software features and navigation tools. For detailed instructions about how to use the ServeRAID Manager program to manage the storage subsystem, see the online help.

System Requirements

This section lists the system requirements for the management station and the client computer.

Management station system requirements

To successfully install and run the ServeRAID Manager program on a management station, you need:

- A computer with an Intel™-compatible 500 MHz processor (IA32, AMD32, or AMD64)
- 256 MB RAM
- 35 MB hard disk drive space
- Microsoft® Windows® Advanced Server 2003, Windows XP, or Windows 2000

Client computer system requirements

To successfully install and run the ServeRAID Manager program on a client computer, you need:

- A computer with an Intel-compatible 500 MHz processor (IA32, AMD32, or AMD64)
- 256 MB RAM
- 35 MB hard disk drive space
- 256 color video mode

On client computers, the ServeRAID Manager program is supported on operating systems, including Microsoft Windows, Linux, Novell Netware, UnixWare, or OpenServer.

Note: When installing the ServeRAID Manager program on client computers, see the operating-system-specific readme files on the IBM *ServeRAID Manager Application* CD for a list of supported operating systems and other operating-system-specific information.

Updating the registry information for the host computer

If the DS300 storage subsystem configuration supports dual controllers, you must perform the following procedure on each host computer if the host computer is connected to one of the DS300 data ports, and is running Microsoft Windows 2000 or Microsoft Windows 2003. You must perform this procedure *after* each time you load or update the Microsoft iSCSI software initiator onto a host computer.

To update the registry information, complete the following steps:

1. Create an Emergency Repair diskette for the system using the instructions in the operating system online help.
2. Click **Start → Run**.
3. In the Run window, type `regedt32` and click **OK**.
4. In the Registry Editor window, double-click **HKEY_LOCAL_MACHINE** to expand the tree.
5. Expand the **SYSTEM** tree.
6. Expand the **ControlSet001** tree.
7. Expand the **Control** tree.
8. Expand the **Class** tree.
9. Double-click the Globally Unique Identifier (GUID) that contains the legacy information option of SCSI. GUIDs are in the form {4D36E97B-E325-11CE-BFC1-08002BE10318}.
10. Click the Parameters key **0000**.
11. Change the value for the MAXRequestHoldTime from 60 to 120:
 - a. In the right pane, double-click **MaxRequestHoldTime**.
 - b. In the String Editor window, change the value from 3c in hex to 78 in hex.
 - c. Click **OK**.
12. Close the Registry Editor window.

Installing the ServeRAID Manager program

This section provides instructions for installing the ServeRAID Manager program on systems running a Microsoft Windows operating system. To install the ServeRAID Manager program on client computers running operating systems other than Windows, see the operating-system-specific readme files on the *IBM ServeRAID Manager Application* CD for installation instructions.

Note: You need administrator privileges to install the ServeRAID Manager program.

To install the ServeRAID Manager program, complete the following steps:

1. Insert the installation CD and wait for the Autorun executable to start the installation. If this does not occur, browse the CD and click **Autorun**.
2. When the installation wizard opens, click **Next**.
3. Read and accept the terms of the license agreement; then, click **Next**.
4. Click **Next** to accept the default installation setup. Alternatively, use the menus to select the ServeRAID components that you want to install, then click **Next**.
5. Create a user name and a password for the management station.

This is the user name and password that you will use to log into the management station.
6. Click **Add User**; then, click **Next**.

7. Click **Install**.

The installation wizard installs the software. This might take a few minutes to complete.

8. When the installation is complete, click **Finish**.

Getting started

This section explains how to begin using the ServeRAID Manager program.

Running ServeRAID Manager

Note: You need administrator privileges to run ServeRAID Manager.

To run ServeRAID Manager as a standalone application, click **Start** → **Programs** → **ServeRAID Manager** → **ServeRAID Manager**.

For an introduction to ServeRAID Manager features, see “Navigating ServeRAID Manager” on page 4.

Adding a management station agent

When you log in for the first time, you must add the management station before you can begin to set up your network storage.

The management station agent is a monitoring agent for network storage. After you add an agent to a management station, you can monitor and configure the attached storage enclosures from a ServeRAID Manager console.

To add a management station agent, complete the following steps:

1. In the Enterprise view, right-click the icon for the Networked storage and select **Add management station**, as shown in the following illustration.

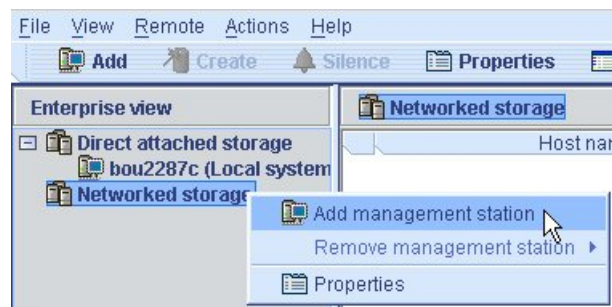

Figure 1. Adding a management station

The Add management station window opens.

2. In the **Type** field, select **Management station**.
3. Enter the host name or TCP/IP address of the management station computer.
4. Enter the management station user name and password, as they were defined during the ServeRAID Manager installation. (In “Installing the ServeRAID Manager program” on page 2, see step 5 on page 2.)
5. Select **Save user name/password**.
6. Click **Connect**.

The management station agent is added.

Removing a management station agent

To remove a management station agent, complete the following steps:

1. In the Enterprise view, right-click **Networked storage**, select **Remove management station**; then, select the management station to be removed.
2. Click **Yes**.

The management station agent is removed.

Adding the storage subsystem to the management station

To add the storage subsystem to the management station, complete the following steps:

1. In the Enterprise view, right-click the management station in the Networked storage tree and select **Add agent**.
2. Type the host name or TCP/IP address for one of the storage subsystem management ports.
3. Enter the administrator password for the storage subsystem.

Note: The administrator password is created when the storage subsystem is installed on the network. It is not the same as the management station password.

4. Click **Add**.

The storage subsystem is added to the management station in the Enterprise view Networked storage tree.

For more information about configuring the storage subsystem and building the network storage, see the ServeRAID Manager help.

Navigating ServeRAID Manager

ServeRAID Manager provides an expandable tree view, or Enterprise view (shown in Figure 2) that shows the systems and controllers you are managing. The Networked storage section of the tree is for management stations with network-attached storage enclosures.

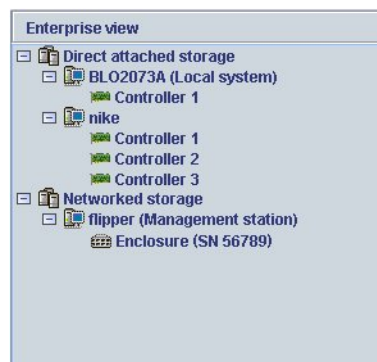

Figure 2. Enterprise view

You can perform most configuration and management tasks by selecting a controller or enclosure from the tree and working with related objects in the Physical and Logical device views (shown in Figure 3 on page 5).

Figure 3 shows how ServeRAID Manager displays the Physical and Logical device views, which show the physical devices and logical devices that are connected to the controller or enclosure.

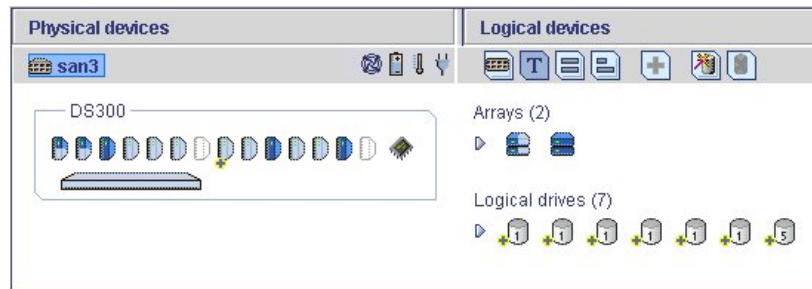

Figure 3. Physical and logical devices view

The Physical devices view (on the left in Figure 3) displays information about the drives, enclosures, and other devices attached to the controller. The devices are shown organized by the channel or port they are connected to and shown in numerical order. The information for each channel or port includes the maximum speed capability, the number of the channel on the controller, and the number of devices attached to the controller.

The Logical devices view (on the right in Figure 3) displays information about the arrays and logical drives created using the physical devices. This information includes the number of arrays and logical drives, the RAID level of each device, and whether a logical drive is protected by a hot spare drive.

In the Physical devices and Logical devices views, you can:

- Collapse or expand a view to see more information about arrays, logical devices, and physical devices.
- Change how drives are displayed (see “Changing how drives are displayed” on page 6).
- Identify components of a logical device (see “Viewing related components” on page 6).

Physical devices view

The Physical Devices view displays physical device information in enclosure view format, as shown in Figure 4. Drives in the enclosure are shown in the physical slots they occupy with the proper vertical or horizontal orientation. Empty slots are shown as drive outlines.

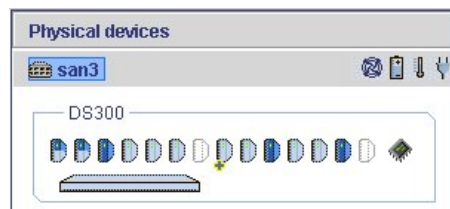



Figure 4. Physical devices view

The indicator icons () report the status of the fan and temperature modules on SAF-TE (enclosure management) devices and other devices that monitor these conditions.

The indicator colors are:

- **Blue**—Normal
- **Yellow**—Warning
- **Red**—Error
- **Gray**—Not applicable to the devices.

For example, the fan indicator changes to yellow when one fan fails; it changes to red when a second fan fails and cooling is no longer adequate.

Logical devices view

The Logical devices view displays information about the logical devices created using the physical devices, including the number of arrays and logical devices, the RAID level of each device, and whether a logical device is protected by a hot spare drive.

You can create and delete logical devices in the Logical devices view by selecting the **Create** option and using the Create wizard.

Changing how drives are displayed

You can choose how information is displayed in the Physical devices view by clicking one of the following icons in the Logical devices view.



Displays the enclosure view. This is the default view.



Displays physical device information in text format.



Displays physical device information in full size capacity format. A full-length bar is displayed for each drive, regardless of capacity. A small segment on each drive is reserved for the RAID signature; this area is indicated by a gray cap at the end of each bar.

Note: A drive shaded in light blue is not part of any disk group.



Displays physical device information in relative size capacity format. A full-length bar is displayed for the largest drive; proportionally shorter bars are displayed for other drives.

Viewing related components

When you click a physical or logical device in the device views, the related components are highlighted.

For example, when you click an array, the associated logical drives are highlighted in the Logical devices view and the physical drives that are members of the array are highlighted in the Physical devices view, as shown in Figure 5 on page 7 and Figure 6 on page 7.

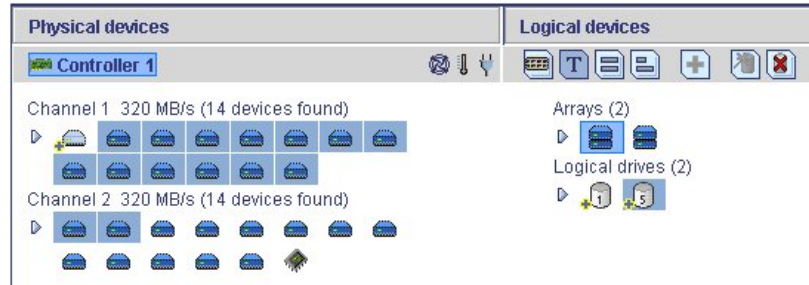

Figure 5. Displaying the logical and physical drives of an array (single controller)

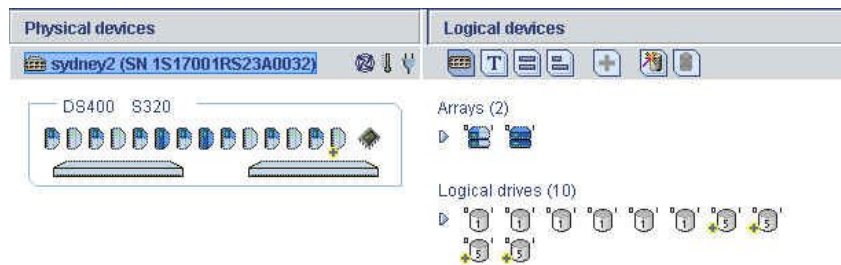

Figure 6. Displaying the logical and physical drives of an array (dual controllers)

For another example, when you click a hot spare, the logical devices protected by that spare are highlighted, as shown in Figure 7.

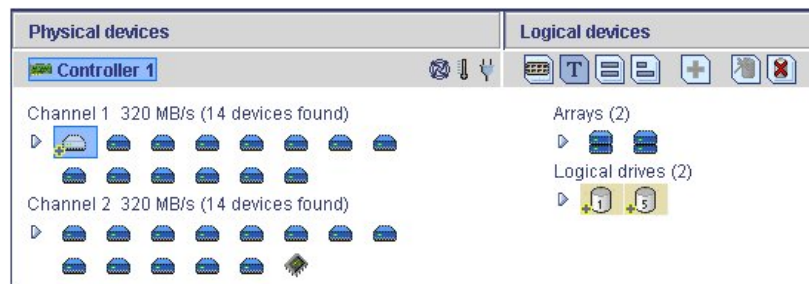

Figure 7. Displaying logical devices protected by a spare

Finding more information

For detailed instructions about how to use the ServeRAID Manager program to manage the storage subsystem, see the ServeRAID Manager help.

Chapter 2. Installing firmware

This chapter provides instructions for downloading and installing firmware on the storage subsystem.

Downloading firmware

To download a new firmware image, go to <http://www.ibm.com/pc/support/>; then, go to the page for your storage subsystem model and configuration. Follow the online instructions to download the file.

Keep the default file name, and save the file to a system that is accessible by IBM ServeRAID Manager.

Updating the firmware

To update the firmware, complete the following steps:

1. In the Enterprise view, click the enclosure that you want to update.
2. Right-click **Update controller images**. The Software Update wizard opens.
3. Click **Next**.

The “Select a software image” window opens.

4. Click **Browse**, select the firmware file; then, click **Next**.

The “Update summary” window opens.

5. Review the update summary, then click **Apply**.

ServeRAID Manager applies the firmware update. The progress meter shows the update status. When the update is complete, the progress meter automatically closes.

6. Restart the controller. (See “Restarting the controller.”)

Restarting the controller

To restart a controller, complete the following steps:

1. In the Physical devices view, right-click the controller and select **Restart enclosure**.
2. Click **Yes** to confirm that you want to restart the controller.

Note: Restarting the controller can take several minutes. Data on the controller is unavailable during that time.

Chapter 3. Configuring a new controller

This chapter provides detailed instructions for configuring a new or replacement controller as part of the storage subsystem.

Note: For detailed instructions about installing a RAID controller, see the *IBM TotalStorage DS300 and DS400 Dual Controller Hardware Installation and User's Guide* on the IBM Documentation CD or on the IBM Support Web site.

Getting started

To configure a new or replacement controller, complete the following steps:

1. **For a single-controller configuration only:** If you are installing a replacement controller, remove (or un-cam but leave in place) the hard disk drives until you are told to replace them later in "Completing the controller configuration" on page 13.
2. Turn on the storage subsystem and connect to controller A through a Telnet session, using the default IP address 192.168.70.123.
3. To log in as the administrator, type `ad`.
4. Type the administrator password. By default, the password is `passw0rd` (all lowercase letters with a zero, not O, in `passw0rd`).
5. On the command line, type `setup` to open the Setup wizard. The Setup wizard helps you enter the information that is required to connect the storage subsystem to a local network.

Note: After you connect to the storage subsystem for the first time, the Setup wizard opens automatically.

6. Using the Setup wizard, change the storage subsystem default configuration settings as required for your network. The default settings are shown in Table 1 and Table 2.

Table 1. Controller A default configuration settings

Controller A settings	Default
Hostname	DS300 / DS400
Domain Name	ibm.com
Timezone [GMT]	GMT-5
New Administrator Password	passw0rd (All lowercase letters with a zero, not O, in passw0rd)
Default Gateway	0.0.0.0
DNS Servers	NO
User DHCP	NO
Management i/f IP Address	192.168.70.123
Management i/f IP Netmask	255.255.0.0
Management i/f Broadcast Address	192.168.255.255

Table 2. Controller B default configuration settings

Controller B settings	Default
Hostname	DS300 / DS400

Table 2. Controller B default configuration settings (continued)

Controller B settings	Default
Domain Name	ibm.com
Management i/f IP Address	192.168.70.124
Management i/f IP Netmask	255.255.0.0
Management i/f Broadcast Address	192.168.255.255

The Setup wizard steps you through a set of prompts. You can type the answers to the prompts and use the three commands that are shown in the following table.

Command	Function
Abort	Quit the Setup wizard without making changes
Back	Go to the previous prompt
Help	Describe the current options

If a prompt has a default value, the default is displayed in square brackets []. Some options take an arbitrary string, in which case the commands **back** and **abort** cannot be used. In those cases, you must enclose the response in double-quotation marks (“xxx”) so that your response is accepted, even if it is the same as a command.

The Setup wizard prompts are described in the following list:

hostname

Type the name for which the system is to be known.

Use the special **back** command to repeat this prompt.

domain name

Type the domain in which the system belongs.

SAN name

Type the Storage Area Network in which the system belongs.

timezone

Type the system time zone.

system Date

Type the system date.

define administrator password

Define whether an administrator password is required. If a password is required, you are prompted for that password, which must be typed twice.

Press Ctrl to not change the password.

Press Enter twice to require no administrator password.

define operator password

Define whether an operator password is required. (For more information, see **define administrator password**.)

dhcp Type yes or no to determine whether to use DHCP to discover the system network values.

If you type yes, the wizard takes you to the Save new configuration prompt (see page 13). If you type no, the wizard continues with prompts about the system main Ethernet interface.

IP address

Type the IP address, for example, 192.193.194.195

netmask

Define the size of the netmask.

A netmask can be represented in several ways. The following examples all refer to the same netmask:

/23	The number of bits set in the network part
255.255.254.0	The set bits displayed in the same way as an IP address
0xffffe00	The mask shown as a hexadecimal number

broadcast address

Type the address to be used for broadcasts. You can use any of the formats described for the **interface manage [interface] broadcast** command, where [interface] is eth0, eth2, or eth3.

default gateway

Type the name or IP address of a router to which packets, for destinations that do not have routes defined for them in the system, are sent. Type no to clear the default gateway.

DNS servers

Type the IP addresses of up to three systems that will act as DNS servers. Type no to clear the list of DNS servers.

save new configuration

After the Setup wizard is finished, the system is configured but the new configuration is not saved immediately in nonvolatile memory. Type yes to save the configuration immediately, or no to defer saving the configuration.

The **save** command saves the configuration.

finish?

Type yes to apply the values you have entered, or no to return to the first prompt and change the values you entered.

Note: If you changed the IP address, you must Telnet to the new IP address to reestablish the Telnet session.

Completing the controller configuration

To finish the controller configuration using ServeRAID Manager, complete the following steps:

1. Start ServeRAID Manager. (For more information, see “Running ServeRAID Manager” on page 3.)
2. Add the management station agent. (For more information, see “Adding a management station agent” on page 3.)
3. Add the enclosure to the management station. (For more information, see “Adding the storage subsystem to the management station” on page 4.)
4. **For a single-controller configuration only:** If you have installed a replacement RAID controller, reinsert the hard disk drives. Wait approximately two minutes, then use ServeRAID Manager to scan for new or removed RDY drives. (For detailed instructions, see the ServeRAID Manager help.)

5. **For a dual-controller configuration only:** See the Technical Update about replacing a controller that comes with the replacement controller and is available on the IBM Support Web site.
6. Configure the storage subsystem using the Configuration wizard. (For detailed instructions, see the ServeRAID Manager help.)

Note: After the storage subsystem is configured, logical drives are displayed as physical drives to the initiator operating system. To set up the initiators, see the initiator documentation.

7. If existing arrays were associated with the RAID controller that you replaced, they are displayed as foreign arrays and can be imported. (For detailed instructions, see the ServeRAID Manager help.)

Chapter 4. Installing a DS300 or DS400 storage subsystem in a Windows cluster server environment

This chapter describes how to install a DS300 or DS400 storage subsystem in a Windows cluster server environment. Before you install the software, make sure that you have read the following information:

- *IBM TotalStorage DS300 and DS400 Dual Controller Hardware Installation and User's Guide*
- Chapter 1, "Installing and running ServeRAID Manager," on page 1

Important: Always check for a readme file on any installation media. A readme file contains important information that was not available when this document was written.

For the latest storage management software and readme files for your operating system, go to <http://www.ibm.com/servers/storage/support/disk/>.

Preinstallation tasks for an iSCSI (DS300) environment

The procedure for installing a DS300 storage subsystem in a cluster server environment includes the following tasks:

1. Installing the Microsoft iSCSI Software Initiator software
2. Installing the ServeRAID Manager software
3. Installing the Microsoft Cluster Server software

iSCSI configuration considerations

You can connect the DS300 storage subsystem to the cluster only using a gigabit Ethernet switch. Figure 8 shows an iSCSI environment using multiple switches.

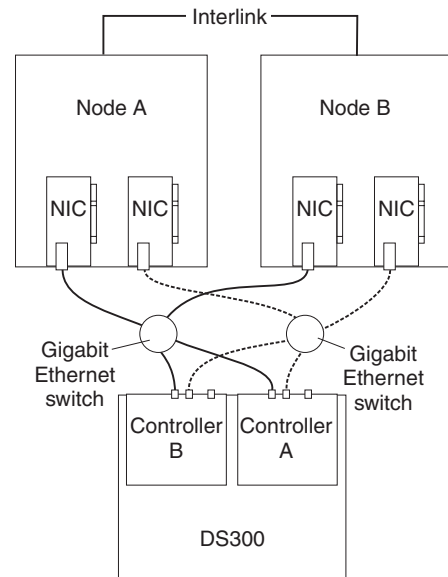

Figure 8. iSCSI cluster configuration

Before connecting the DS300 to the cluster, read the following Microsoft requirements for iSCSI cluster support. For more information about Microsoft iSCSI support, see the Microsoft Web site <http://www.microsoft.com/windowsserver2003/technologies/storage/iscsi/default.mspx>

- The iSCSI traffic must be on a private network (not shared), both for security reasons and for performance reasons. Any “networking standard practice” method for achieving this end is acceptable, and includes any of the following:
 - Physically separate, dedicated iSCSI traffic network.
 - Physically shared network with the iSCSI traffic running on a private VLAN. The switch hardware must provide CoS (or QoS) guarantees for the private VLAN.
- If multiple clusters or systems are connected to the same iSCSI network, proper segregation must be provided.
- The use of session Authentication (CHAP minimum) is mandatory. This provides both a degree of security as well as segregation.

Installing the Microsoft iSCSI Software Initiator

The Microsoft iSCSI Software Initiator is an iSCSI device driver that is used to connect to iSCSI devices using the Windows TCP/IP stack using NICs.

To download the iSCSI software initiator from the Microsoft Download Center, go to <http://www.microsoft.com/windowsserver2003/technologies/storage/iscsi/default.mspx>. For detailed information about the installing and configuring the iSCSI software initiator, see the *Microsoft iSCSI Software Initiator Users Guide*, which is available from the Microsoft Download Center.

Preinstallation tasks for a Fibre Channel (DS400) environment

The procedure for installing a storage subsystem in a cluster server environment includes the following tasks:

1. Installing the Fibre Channel host adapters
2. Installing the multi-path I/O device specific module (MPIO DSM) software
3. Installing the ServeRAID Manager software
4. Installing the Microsoft Cluster Server software

Fibre Channel configuration considerations

You can connect the storage subsystem to the cluster node either directly or through Fibre Channel switches. Figure 9 on page 17 shows a typical directly-attached configuration. Figure 10 on page 17 shows a typical Fibre Channel switch connection configuration. Both configurations are fully redundant.

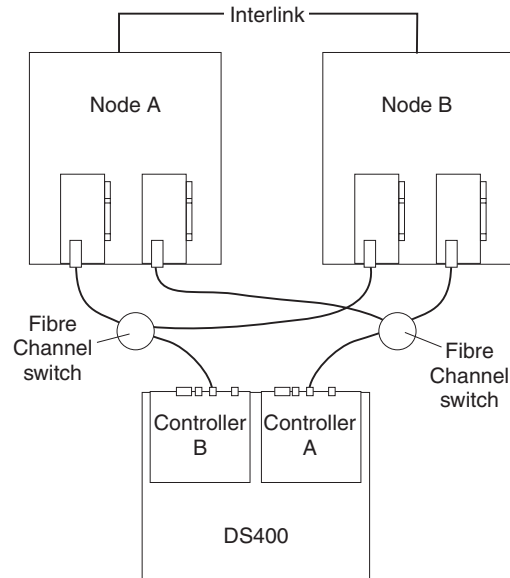

Figure 9. Fibre Channel direct-attached cluster solution

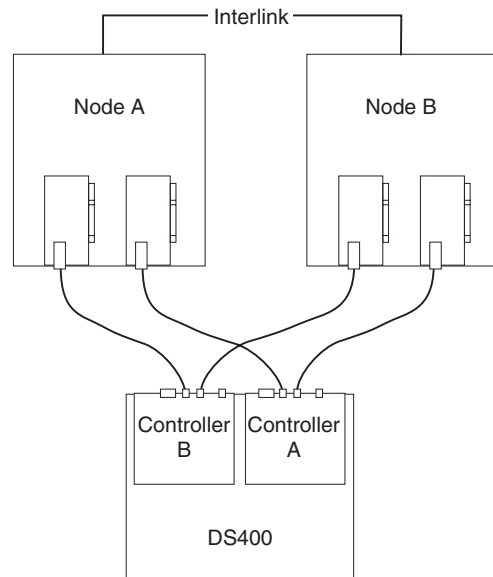

Figure 10. Fibre Channel switch cluster solution

Installing the Fibre Channel host adapters

To install the Fibre Channel host adapters, see the specific installation requirements and procedures in the documentation that comes with the host adapter. After you install the host adapter, install the correct host adapter device driver.

To use the dual path configuration, complete the following steps:

1. Install two host adapters in each node.
2. Connect two Fibre Channel cables from each node to the storage subsystem.
3. Install the multi-path I/O (MPIO) DSM software as described in “Installing the multi-path I/O DSM software” on page 18.

Installing the multi-path I/O DSM software

To install the MPIO DSM software on a host system using multiple connections to the external storage enclosure, complete the following steps:

1. To download the latest MPIO DSM from the IBM Support Web site, go to <http://www.ibm.com/pc/support/>.
2. On a command prompt or using Windows, run the installation program.
3. After the software is installed, restart the host system.
4. To be sure the software is installed correctly, on the desktop, right-click **My computer**, and click **Manage**. In the Computer Management window, a disk device is displayed as a Multi-Path Disk Device.

Installing a DS300 or DS400 storage subsystem in a cluster environment

The following procedures describe how to install the storage management software in a cluster environment.

Note: The storage management software consists of host bus adapter device drivers, iSCSI software initiator software, MPIO DSM software, and the ServeRAID Manager software.

Windows 2000

Note: Microsoft does not support an iSCSI cluster in a Windows 2000 operating system environment.

Before you begin, make sure that the host bus adapters, device drivers, and MPIO DSM software are installed on each cluster node.

To install the storage management software and the cluster service software on a server running the Microsoft Windows 2000 operating system, complete the following steps:

1. Shut down node B. Turn on node A.
2. Install the ServeRAID Manager software on node A. For more information, see “Installing the ServeRAID Manager program” on page 2.
3. Use the ServeRAID Manager software to define and map the shared logical drives to the cluster nodes.

Note: You might need to restart the first node of the cluster to see the logical drives (LUNs) that are added.

4. Format all shared logical drives as NT File System (NTFS), assign volume labels, and specify a drive letter for each.

Important: You must assign a permanent (sticky) drive letter to the shared logical drive on both cluster nodes. The two nodes must have the same drive letters on each shared drive. If you do not assign permanent drive letters, Windows might assign different drive letters on each node.

5. Shut down node A. Start node B.
6. To be sure that the drive letters for the cluster configuration are defined correctly, complete the following steps:
 - a. Click **Start** → **Programs** → **Administrative Tools** → **Computer Management**. The Computer Management window opens.

- b. Click **Storage Disk Management**.
7. Make sure that the following conditions are met:
 - The same logical drives are displayed on each cluster node.
 - Each cluster node has the same number of partitions defined on the logical drives.
 - Drive letters are assigned to the configured logical drives.
 - The drive letters on the partitions are the same on both cluster nodes.
8. Shut down node B. Start node A.
9. Install the cluster server software. For more information, see “Installing the cluster server software” on page 20.

Windows Server 2003

To install the storage management software and the cluster services software on a server running the Microsoft Windows Server 2003 operating system, complete the following steps.

Notes:

- **For DS300 iSCSI configurations:** Before you begin, make sure that the Microsoft iSCSI Software Initiator software is installed on each cluster node. For more information, see “Installing the Microsoft iSCSI Software Initiator” on page 16.
- **For DS400 Fibre Channel configurations:** Before you begin, make sure that the host bus adapters, device drivers, and MPIO DSM software are installed on each cluster node.

1. Shut down node B. Turn on node A.
2. Install the ServeRAID Manager software on node A. For more information, see “Installing the ServeRAID Manager program” on page 2.
3. Use the ServeRAID Manager software to define and map the shared logical drives to the cluster nodes.

Note: You might need to restart the first node of the cluster to see the logical drives (LUNs) that are added.

4. Format all shared logical drives as NT File System (NTFS), assign volume labels, and specify a drive letter for each.

Important: You must assign a permanent (sticky) drive letter to the shared logical drive on both cluster nodes. The two nodes must have the same drive letters on each shared drive. If you do not assign permanent drive letters, Windows might assign different drive letters on each node.

5. Shut down node A. Turn on node B.
6. To be sure that the drive letters for the cluster configuration are defined correctly, complete the following steps:
 - a. Click **Start → Programs → Administrative Tools → Computer Management**. The Computer Management window opens.
 - b. Click **Storage Disk Management**.
7. Make sure that the following conditions are met:
 - The same logical drives are displayed on each cluster node.
 - Each cluster node has the same number of partitions defined on the logical drives.
 - Drive letters are assigned to the configured logical drives.
 - The drive letters on the partitions are the same on both cluster nodes.

8. Shut down node B. Start node A.
9. Install the cluster server software. For more information, see “Installing the cluster server software.”

Installing the cluster server software

The following sections describe how to install the cluster server software on Windows operating systems.

Windows 2000

Important: Do not perform this procedure unless you installed the necessary storage management software components on both cluster nodes.

To install the cluster server software on node A and node B, complete the following steps:

1. Install the cluster server software on node A:
 - a. See the Microsoft Cluster Server (MSCS) documentation for the correct procedure to install the cluster server software.
2. Install the cluster server software on node B, as follows:
 - a. See the MSCS documentation for the correct procedure to install the Cluster Server software.

Note: During installation, specify that you want to form a new cluster.

- b. After the system restarts, leave node A running.

3. After you install MSCS, reinstall Service Pack 4.
 - a. See the MSCS documentation for the correct procedure to install the Cluster Server software.
 - b. After the system restarts, leave node B running.

Note: For more information about installing the service pack in a cluster environment, see the Microsoft Knowledge Base article Q174799.

4. Check the software installation as follows:
 - a. On either node A or node B, click **Start → Programs → Administrative Tools → Cluster Administration**.
 - b. In the **Cluster or Server Name** field, type either the name of the cluster or the name or IP address of one of the nodes.

If the installation is successful, the computer names of both nodes are displayed on the left side of the Cluster Administrator window.
 - c. Make sure that the cluster disk groups can be moved between cluster nodes.
5. If both node names are not displayed on the left side of the Cluster Administrator window, reinstall the cluster server software. If the problem persists, contact your IBM technical support representative.

Windows Server 2003

Important: Do not perform this procedure unless the necessary storage management software components are installed on all cluster nodes.

To install the cluster server software on cluster nodes, complete the following steps:

1. Install the cluster server software on the first node of the cluster. See the Microsoft Cluster Server (MSCS) documentation for the correct procedure to install the cluster server software.

Note: During installation, specify that you want to form a new cluster.

2. In the Cluster Administrator window, make sure that all of the cluster disk groups can be varied online and offline with no problems.
3. Install the cluster server software on the second node of the cluster. See the Microsoft Cluster Server (MSCS) documentation for the correct procedure to install the cluster server software.

Note: During installation, specify that you want to join the existing cluster. Make sure that you add the cluster nodes one at a time.

4. If all node names are not displayed on the left side of the Cluster Administrator window, reinstall the cluster server software. If the problem persists, contact your IBM technical support representative.

Upgrading from a previous version of the storage management software

Be sure that you are familiar with the steps required in a new installation before you continue with the following upgrade procedure.

Choose one of the following two procedures:

- Performing a scheduled upgrade: A scheduled upgrade requires scheduling downtime on your cluster server to upgrade the controller firmware and storage management software. The services and resources offered by the cluster are not available during the upgrade. If you choose this upgrade method, it is important that you perform the upgrade during off-peak workload time.

Note: The scheduled upgrade is the preferred procedure for upgrading a cluster server configuration.

- Performing a rolling upgrade: A rolling upgrade requires upgrading the storage management software first in one of the cluster nodes and then in each of the remaining cluster nodes, one cluster node a time, so that the services and resources offered by the cluster are always available.

Important: Do not upgrade your storage subsystem firmware until you have upgraded the storage management software on all cluster nodes and management stations.

Performing a scheduled upgrade

The following sections describe how to perform a scheduled upgrade on Windows operating systems.

Windows 2000

To perform a scheduled upgrade on computers that are running the Windows 2000 operating system, complete the following steps:

1. Click **Start** → **Programs** → **Administrative Tools** → **Services**. The Services window opens.
2. Shut down node B.
3. From node A, uninstall the components from the previous version of the storage management software in the following order (as applicable):
 - a. MPIO DSM
 - b. Microsoft iSCSI Software Initiator
 - c. ServeRAID Manager
4. Make sure that the latest IBM host adapter device drivers are installed on node A. Go to <http://www.ibm.com/servers/storage/support/disk/> to download the latest device drivers.
5. Install the latest version of the storage management software on node A. For more information, see “Installing the ServeRAID Manager program” on page 2, “Installing the Microsoft iSCSI Software Initiator” on page 16, and “Installing the Fibre Channel host adapters” on page 17.
6. Shut down node A.
7. Restart node B.
8. From node B, uninstall the components from the previous version of the storage management software.
9. Make sure that the latest IBM host adapter device drivers are installed on node B. Go to <http://www.ibm.com/servers/storage/support/disk/> to download the latest device drivers.
10. Install the latest version of the storage management software on node B. For more information, see “Installing the ServeRAID Manager program” on page 2, “Installing the Microsoft iSCSI Software Initiator” on page 16, and “Installing the Fibre Channel host adapters” on page 17.
11. Shut down node B.
12. Start up one node at a time and complete the following procedure:
 - a. Click **Start** → **Programs** → **Administrative Tools** → **Services**. The Services window opens.
 - b. From the list of displayed services, right-click the cluster server. Click **Automatic** to change the cluster server startup option.
 - c. Start the cluster server service on node B.

Windows Server 2003

To perform a scheduled upgrade on computers that are running the Windows Server 2003 operating system, complete the following steps:

1. Before you install the storage management software, perform the following steps in each of the cluster nodes in the cluster:
 - a. Click **Start** → **Programs** → **Administrative Tools** → **Services**. The Services window opens.
 - b. From the list of displayed services, right-click the cluster server. Then click **Manual**.
 - c. Stop the cluster server on all nodes in the cluster configuration.
2. From each cluster node, uninstall the components from the previous version of the storage management software in the following order (as applicable):
 - a. MPIO DSM
 - b. Microsoft iSCSI Software Initiator
 - c. ServeRAID Manager

3. Make sure that the latest IBM host adapter device drivers are installed in each cluster node. Go to <http://www.ibm.com/servers/storage/support/disk/> to download the latest device drivers.
4. Install the latest version of the storage management software in each cluster node. For more information, see “Installing the ServeRAID Manager program” on page 2, “Installing the Microsoft iSCSI Software Initiator” on page 16, and “Installing the Fibre Channel host adapters” on page 17.
5. Start up one node at a time and complete the following steps for each node:
 - a. Click **Start** → **Programs** → **Administrative Tools** → **Services**. The Services window opens.
 - b. From the list of displayed services, right-click the cluster server. Click **Automatic** to change the cluster server startup option.
 - c. Manually start the cluster server service.
6. Open Cluster Administrator windows and verify that the cluster groups can be brought online. If not, contact your IBM service representative for support.

Performing a rolling upgrade

This section describes how to perform a rolling upgrade on Windows operating systems.

Important: If you have applications installed in the cluster server environment that do not support a rolling upgrade, perform one of the following tasks:

- Put those resources offline before the upgrade; then, put them back online after the upgrade.
- Perform a scheduled upgrade. A scheduled upgrade requires scheduling downtime on your cluster server to upgrade the controller firmware and storage management software.

Windows 2000

To perform a rolling upgrade on computers that are running the Windows 2000 operating system, complete the following steps:

1. From node A, open Cluster Administrator.
2. Double-click the Active Groups folder in the right pane of the Cluster Administrator window.
3. Select each group listed and move them to node B.
4. Select node A. Then click **File** → **Pause Node** to pause cluster service in node A.
5. From node A, uninstall the components from the previous version of the storage management software in the following order (as applicable):
 - a. MPIO DSM
 - b. Microsoft iSCSI Software Initiator
 - c. ServeRAID Manager
6. Make sure that the latest IBM host adapter device drivers are installed on node A. Go to <http://www.ibm.com/servers/storage/support/disk/> to download the latest device drivers.
7. Install the latest version of the storage management software on node A. For more information, see “Installing the ServeRAID Manager program” on page 2, “Installing the Microsoft iSCSI Software Initiator” on page 16, and “Installing the Fibre Channel host adapters” on page 17.

8. Run Cluster Administrator. Then click **File → Resume Node** to resume cluster service in node A.
9. From node B, open Cluster Administrator.
10. Double-click the Active Groups folder in the right pane of the Cluster Administrator window.
11. Select each group listed and move them to node A.
12. Select node B. Then click **File → Pause Node** to pause cluster service in node B.
13. From node B, uninstall the components from the previous version of the software.
14. Make sure that the latest IBM host adapter device drivers are installed on node B. Go to <http://www.ibm.com/servers/storage/support/disk/> to download the latest device drivers.
15. Install the latest version of the storage management software on node B. For more information, see Chapter 1, “Installing and running ServeRAID Manager,” on page 1.
16. Run Cluster Administrator. Then click **File → Resume Node** to resume cluster service in node B.

Windows Server 2003

To perform a rolling upgrade on computers that are running the Windows Server 2003 operating system, complete the following steps:

1. In the first node of the cluster, open the Cluster Administrator window.
2. Double-click the Active Groups folder in the right pane of the Cluster Administrator window.
3. Select each of the active groups listed in the first cluster node and move them to other nodes in the cluster configuration. Make sure that the cluster groups come online successfully.
4. Select the first node of the cluster in the Cluster Node Tree view and click **File → Pause Node** to pause cluster service in that node.
5. From node A, uninstall the components from the previous version of the storage management software in the following order (as applicable):
 - a. MPIO DSM
 - b. Microsoft iSCSI Software Initiator
 - c. ServeRAID Manager
6. Make sure that the latest IBM host adapter device drivers are installed in each cluster node. Go to <http://www.ibm.com/servers/storage/support/disk/> to download the latest device drivers.
7. Install the latest version of the storage management software in the first cluster node. For more information, see “Installing the ServeRAID Manager program” on page 2, “Installing the Microsoft iSCSI Software Initiator” on page 16, and “Installing the Fibre Channel host adapters” on page 17.
8. In the Cluster Administrator window, select the first node of the cluster and click **File → Resume Node** to resume cluster services in the first cluster node.
9. Move all cluster groups that were active in the first cluster node back to it. Make sure that the cluster groups can be brought online in the first cluster node with no problems.
10. Repeat steps 1 through 9 for each of the other nodes in the cluster configuration. Perform all steps for each cluster node, one cluster node at a time.

Upgrading from Windows 2000 Advanced Server to Windows Server 2003 in a cluster configuration

Note: Always perform a full system backup before you perform any upgrade procedure.

Important: If you have applications that are installed in the cluster server environment that do not support a rolling upgrade, perform one of the following tasks:

- Put those applications offline before the upgrade. Then put them back online after the upgrade.
- Perform a scheduled upgrade. A scheduled upgrade requires scheduling downtime on your cluster server to upgrade the controller firmware and storage management software.

To upgrade from Windows 2000 Advanced Server to Windows Server 2003 Enterprise Edition, perform the following steps:

1. On node A, open the Cluster Administrator window.
2. Double-click the Active Groups folder in the right pane of Cluster Administrator.
3. Move all active cluster groups in node A to node B. Make sure that the cluster groups come online successfully in node B.
4. Select node A. Click **File → Pause Node** to pause cluster service in node A.
5. Follow the instructions from Microsoft to upgrade node A from Windows 2000 Advanced Server to Windows Server 2003 Enterprise Edition.

Note: During the upgrade, the existing cluster server installation is detected and clustering for Windows 2000 Advanced Server is installed. When the upgrade is complete, node A rejoins the cluster and remains paused.

6. Make sure that the latest IBM host adapter device drivers are installed on node A. Go to <http://www.ibm.com/servers/storage/support/disk/> to download the latest device drivers.
7. Make sure that node A was successfully upgraded to Windows Server 2003 Enterprise Edition.
8. Install the latest version of the storage management software on node A. For more information, see “Installing the ServeRAID Manager program” on page 2, “Installing the Microsoft iSCSI Software Initiator” on page 16, and “Installing the Fibre Channel host adapters” on page 17.
9. In the Cluster Administrator window, select node A and click **File → Resume Node** to resume cluster service in node A.
10. Move the cluster groups that were active in node A back to node A.
11. On node B, open the Cluster Administrator window.
12. Double-click the Active Groups folder in the right pane of Cluster Administrator.
13. Make sure that all cluster groups failover to node A successfully.
14. Select node B. Click **File → Pause Node** to pause cluster service in node B.
15. Follow the instructions from Microsoft to upgrade node B from Windows 2000 Advanced Server to Windows Server 2003 Enterprise Edition.

Note: During the upgrade, the existing cluster server installation is detected and clustering for Windows 2000 Advanced Server is installed. When the upgrade is complete, node B rejoins the cluster and remains paused.

16. Make sure that the latest IBM host adapter device drivers are installed on node A. Go to <http://www.ibm.com/servers/storage/support/disk/> to download the latest device drivers.
17. Make sure that node B was successfully upgraded to Windows Server 2003 Enterprise Edition.
18. Install the latest version of the storage management software in node B. For more information, see “Installing the ServeRAID Manager program” on page 2, “Installing the Microsoft iSCSI Software Initiator” on page 16, and “Installing the Fibre Channel host adapters” on page 17.
19. In the Cluster Administrator window, select node B and click **File → Resume Node** to resume cluster service in node B.
20. In the Cluster Administrator window, move the cluster groups that were active in node B back to node B. Make sure that they come online with no problems.
21. If there are more than two nodes in a cluster, repeat step 11 on page 25 through step 20 for each of the remaining nodes in a cluster, one cluster node at a time.

Appendix A. Using the FlashCopy Management Command Line Tool

This appendix provides detailed instructions for using the Flashcopy Management Command Line Tool. This tool enables you to take flashcopies (also known as *snapshots*) of application databases.

Introduction

You can use the Flashcopy Management Command Line Tool to create and manage flashcopies of application databases.

A *flashcopy* is a frozen image of an application database at a particular point in time. You can use a flashcopy to back up an application database, and use it as a rollback point in case of a future problem with the application.

Using the Flashcopy Management Command Line Tool, you can:

- List Mini Snap Agents available on the IPSAN
- List available databases
- Take a flashcopy of the database
- Schedule a flashcopy of the database
- Rollback to a flashcopy
- Delete a flashcopy and its associated metadata
- Print usage information

Flashcopy Management Command Line Tool glossary

This section provides definitions for terms used in the rest of this appendix to describe the commands and options of the Flashcopy Management Command Line Tool.

Agent A machine on the network running at least one instance of a database server application that holds information on network storage volumes and disks.

Application

A database server application type that can be used to store network storage information.

Appointment

An entry in the diary.

Database

The name of the database of the given instance running on the Agent.

Diary

A scheduling service available on the host that enables you to schedule jobs.

Host

The machine on the network that runs the IBM ServeRAID Manager network storage management station.

Initiator

A device that begins a SCSI transaction by issuing a command to another device (a target). Typically a SCSI host is the initiator, but a target can also become an initiator.

Instance

A specific instance of a database server application.

Snapshot

A collection of data representing the state of a network storage device at a specific moment in time.

Command line syntax and output

The Flashcopy Management Command Line Tool uses this syntax:

```
sstool host host_username host_password command [options]
```

where:

- *host* is a name or IP address of the management service. A host can optionally have a port number specified. Otherwise, the Flashcopy Management Command Line Tool uses 8003 by default.

For example:

```
samplehost:8000
```

```
192.168.0.2:8000
```

```
192.168.0.2
```

- *host_username* and *host_password* are the user name and password used to log in to a management station.
- *command [options]* describes the action to be performed by the Flashcopy Management Command Line Tool. A command can have options associated with it. (See “Commands.”)

Return values

The return values are:

- 0 - Success
- 1 - Invalid parameters
- 2 - Subsystem error

Output

The Flashcopy Management Command Line Tool prints results to a standard output in tabular comma-delimited format. The order and meaning of the column are specific to each command. For more information, see “Commands.”

Note: The Flashcopy Management Command Line Tool handles handle `'/'` as an option prefix instead of `'-'` or `'--'` for DOS and Microsoft Windows users.

Commands

This section provides detailed descriptions of the Flashcopy Management Command Line Tool commands and their options.

list_agents

Command: list_agents

Options: None

Description: Returns a list of flashcopy agents on the IPSAN (that is, a list of hosts with flashcopy agents on them)

list_server_instances

Command: list_server_instances

Options:

-a	The name of the machine on the network that runs storage volume/disk database servers
--d	The network domain
--au	The agent user login name
--ap	The agent user password
--app	The database server application type

Description: Returns a list of server instances available on a flashcopy agent.

list_instance_databases

Command: list_instance_databases

Options:

-a	The name of the machine on the network that runs storage volume/disk database servers
--d	The network domain
--au	The agent user login name
--ap	The agent user password
--app	The database server application type
-i	The server instance name (the name of the instance of the database server of a given application type running on the mini snap agent)
--iu	The instance user login name
--ip	The instance user password

Description: Returns a list of databases available on a server instance.

take_snapshot

Command: take_snapshot

Options:

-a	The name of the machine on the network that runs storage volume/disk database servers
--d	The network domain
--au	The agent user login name
--ap	The agent user password
--app	The database server application type
-i	The server instance name (the name of the instance of the database server of a given application type running on the mini snap agent)
--iu	The instance user login name
--ip	The instance user password

--db	The database (the name of the database of a given instance running on the mini snap agent)
--ini	Initiator
--dbu	The database user login name
--dbp	The database user password
--NAME	The flashcopy (snapshot) name

Description: Takes a flashcopy of the database.

schedule_snapshot

Command: schedule_snapshot

Options:

-a	The name of the machine on the network that runs storage volume/disk database servers
--d	The network domain
--au	The agent user login name
--ap	The agent user password
--app	The database server application type
-i	The server instance name (the name of the instance of the database server of a given application type running on the mini snap agent)
--iu	The instance user login name
--ip	The instance user password
--db	The database (the name of the database of a given instance running on the mini snap agent)
--ini	Initiator
--dbu	The database user login name
--dbp	The database user password
--NAME	The flashcopy (snapshot) name

Scheduling options:

Option	Value	Description
--MINUTE	0-59	The minute within the hour
--HOUR	0-23	The hour within the 24 hour period
--DAY	1-31	The day of the month
--WEEKDAY	0-6	The weekday
--MONTH	1-12	The month of the year
--YEAR	valid year	The year

In the scheduling options, *value* means that the task will run every unit of time. Values can also be given as a list values, separated by commas. For example:

```
--MINUTE 10,20,30
--DAY 5,25
```

Description: Schedules the flashcopy. The time pattern of the flashcopy is defined using the scheduling options as shown in “Scheduling options”.

list_scheduled

Command: list_scheduled

Options: None

Description: Returns a list of scheduled jobs on the management station.

unschedule_snapshot

Command: unschedule_snapshot

Options:

--NAME The flashcopy (snapshot) name

Description: Removes a flashcopy job from the host diary.

roll_back

Command: roll_back

Options:

-a	The name of the machine on the network that runs storage volume/disk database servers
--d	The network domain
--au	The agent user login name
--ap	The agent user password
--app	The database server application type
-i	The server instance name (the name of the instance of the database server of a given application type running on the mini snap agent)
--iu	The instance user login name
--ip	The instance user password
--db	The database (the name of the database of a given instance running on the mini snap agent)
--dbu	The database user login name
--dbp	The database user password
--NAME	The flashcopy (snapshot) name

Description: Rolls back the database to a specific flashcopy.

delete_snapshot

Command: delete_snapshot

Options:

-a	The name of the machine on the network that runs storage volume/disk database servers
--d	The network domain

--au	The agent user login name
--ap	The agent user password
--app	The database server application type
-i	server instance name (the name of the instance of the database server of a given application type running on the mini snap agent)
--iu	The instance user login name
--ip	The instance user password
--db	Database (the name of the database of a given instance running on the mini snap agent)
--dbu	The database user login name
--dbp	The database user password
--NAME	The flashcopy (snapshot) name

Description: Deletes a flashcopy and its associated metadata.

list_snapshots

Command: list_snapshots

Options: None

Description: Lists all flashcopies.

help

Command: help

Options: None

Description: Prints this document to standard output.

Appendix B. Notices

This information was developed for products and services offered in the U.S.A.

IBM may not offer the products, services, or features discussed in this document in other countries. Consult your local IBM representative for information on the products and services currently available in your area. Any reference to an IBM product, program, or service is not intended to state or imply that only that IBM product, program, or service may be used. Any functionally equivalent product, program, or service that does not infringe any IBM intellectual property right may be used instead. However, it is the user's responsibility to evaluate and verify the operation of any non-IBM product, program, or service.

IBM may have patents or pending patent applications covering subject matter described in this document. The furnishing of this document does not give you any license to these patents. You can send license inquiries, in writing, to:

*IBM Director of Licensing
IBM Corporation
North Castle Drive
Armonk, NY 10504-1785
U.S.A.*

INTERNATIONAL BUSINESS MACHINES CORPORATION PROVIDES THIS PUBLICATION "AS IS" WITHOUT WARRANTY OF ANY KIND, EITHER EXPRESS OR IMPLIED, INCLUDING, BUT NOT LIMITED TO, THE IMPLIED WARRANTIES OF NON-INFRINGEMENT, MERCHANTABILITY OR FITNESS FOR A PARTICULAR PURPOSE. Some states do not allow disclaimer of express or implied warranties in certain transactions, therefore, this statement may not apply to you.

This information could include technical inaccuracies or typographical errors. Changes are periodically made to the information herein; these changes will be incorporated in new editions of the publication. IBM may make improvements and/or changes in the product(s) and/or the program(s) described in this publication at any time without notice.

Any references in this information to non-IBM Web sites are provided for convenience only and do not in any manner serve as an endorsement of those Web sites. The materials at those Web sites are not part of the materials for this IBM product, and use of those Web sites is at your own risk.

IBM may use or distribute any of the information you supply in any way it believes appropriate without incurring any obligation to you.

Some software may differ from its retail version (if available) and may not include all user manuals or all program functionality.

IBM makes no representations or warranties regarding third-party products or services.

Edition notice

© COPYRIGHT INTERNATIONAL BUSINESS MACHINES CORPORATION, 2004, 2005. All rights reserved.

Trademarks

The following terms are trademarks of International Business Machines Corporation in the United States, other countries, or both:

Active Memory	Predictive Failure Analysis
Active PCI	PS/2
Active PCI-X	ServeRAID
Alert on LAN	ServerGuide
BladeCenter	ServerProven
C2T Interconnect	TechConnect
Chipkill	Tivoli
EtherJet	TotalStorage
e-business logo	Update Connector
FlashCopy	Wake on LAN
IBM	XA-32
IBM (logo)	XA-64
IntelliStation	X-Architecture
NetBAY	Xcel4
Netfinity	XpandOnDemand
NetView	xSeries
OS/2 WARP	

Intel, MMX, and Pentium are trademarks of Intel Corporation in the United States, other countries, or both.

Microsoft, Windows, and Windows NT are trademarks of Microsoft Corporation in the United States, other countries, or both.

Adaptec and HostRAID are trademarks of Adaptec, Inc., in the United States, other countries, or both.

Linux is a trademark of Linus Torvalds in the United States, other countries, or both.

Red Hat, the Red Hat “Shadow Man” logo, and all Red Hat-based trademarks and logos are trademarks or registered trademarks of Red Hat, Inc., in the United States and other countries.

Other company, product, or service names may be trademarks or service marks of others.

Index

A

- adding a management station agent 3
- adding a storage subsystem to a management station 4

C

- client computer system requirements 1
- cluster server installation
 - Fibre Channel configuration 16
 - installing cluster server software (Windows 2000) 20
 - installing cluster server software (Windows 2003) 21
 - installing Microsoft iSCSI Software Initiator 16
 - installing multi-path I/O DSM software 18
 - installing storage-management software (Windows 2000) 18
 - installing storage-management software (Windows 2003) 19
 - iSCSI configuration 15
 - upgrading from previous version of storage-management software 21
 - upgrading from Windows 2000 to Windows Server 2003 25
- cluster server software, installing 20
- command-line tool (Flashcopy Management)
 - commands 28
 - glossary 27
 - overview 27
 - syntax and output 28
- commands, Flashcopy Management Tool 28
- controller
 - restarting using ServeRAID Manager 9
- controller firmware
 - downloading 9
 - updating 9
- controller, dual DS300, updating registry information 2

D

- displaying drives in ServeRAID Manager 6
- downloading controller firmware updates 9
- DS300 dual controller, updating registry information 2

E

- Enterprise view in ServeRAID Manager 4

F

- Fibre Channel configuration in cluster server environment 16
- Fibre Channel host adapters, installing in cluster server environment 17

- firmware, controller
 - downloading 9
 - updating 9
- FlashCopy Management Command Line Tool
 - commands 28
 - glossary 27
 - overview 27
 - syntax and output 28

G

- glossary for command-line tool 27

H

- host adapters, installing in cluster server environment 17

I

- installing ServeRAID Manager
 - procedure steps 2
 - system requirements 1
- iSCSI configuration in cluster server environment 15
- iSCSI software initiator, installing 16

L

- Logical devices view in ServeRAID Manager 6

M

- management station system requirements 1
- Microsoft iSCSI Software Initiator, installing 16
- MPIO DSM, installing 18
- multi-path I/O DSM software, installing 18

N

- navigating ServeRAID Manager 4

P

- Physical devices view in ServeRAID Manager 5

R

- registry information, updating for DS300 dual controller 2
- removing a management station agent 4
- requirements, system 1
- restarting controller using ServeRAID Manager 9

S

- ServeRAID Manager, installing
 - procedure steps 2
 - system requirements 1
- ServeRAID Manager, using
 - adding a management station agent 3
 - adding a storage subsystem to a management station 4
 - displaying drives 6
 - Logical devices view 6
 - navigating 4
 - Physical devices view 5
 - removing a management station agent 4
 - starting 3
 - viewing related components 6
- Setup wizard
 - starting 11
 - using 12
- starting ServeRAID Manager 3
- storage-management software, installing in cluster server environment (Windows 2000) 18
- storage-management software, installing in cluster server environment (Windows 2003) 19
- syntax and output of command-line tool 28
- system requirements 1

T

- Telnet session, using to configure new controller 11
- trademarks 34

U

- updating controller firmware 9
- upgrading from previous version of storage-management software
 - performing a rolling upgrade (Windows 2000) 23
 - performing a rolling upgrade (Windows 2003) 24
 - performing a scheduled upgrade (Windows 2000) 21
 - performing a scheduled upgrade (Windows 2003) 22
- upgrading from Windows 2000 to Windows Server 2003 in a cluster server configuration 25
- using ServeRAID Manager
 - adding a management station agent 3
 - adding a storage subsystem to a management station 4
 - displaying drives 6
 - Logical devices view 6
 - navigating 4
 - Physical devices view 5
 - removing a management station agent 4
 - starting 3
 - viewing related components 6

V

- viewing related components in ServeRAID Manager 6

W

- Windows cluster server installation
 - Fibre Channel configuration 16
 - installing cluster server software (Windows 2000) 20
 - installing cluster server software (Windows 2003) 21
 - installing Microsoft iSCSI Software Initiator 16
 - installing multi-path I/O DSM software 18
 - installing storage-management software (Windows 2000) 18
 - installing storage-management software (Windows 2003) 19
- iSCSI configuration 15
- upgrading from previous version of storage-management software 21
- upgrading from Windows 2000 to Windows Server 2003 25



Part Number: 31R1082

Printed in USA

(1P) P/N: 31R1082

