

IBM System x3950 Type 8878 and System x3950 E
Type 8879



User's Guide

IBM System x3950 Type 8878 and System x3950 E
Type 8879



User's Guide

Note: Before using this information and the product it supports, read the general information in “Notices,” on page 89.

5th Edition (November 2006)

© Copyright International Business Machines Corporation 2006. All rights reserved.

US Government Users Restricted Rights – Use, duplication or disclosure restricted by GSA ADP Schedule Contract with IBM Corp.

Contents

Safety	v
Chapter 1. The System x3950 and System x3950 E server	1
Related documentation	1
Notices and statements in this document	2
Features and specifications	3
What your server offers	5
Reliability, availability, and serviceability	7
IBM Director	8
The UpdateXpress program	8
Server controls, connectors, LEDs, and power	9
Front view	9
Rear view	11
Server power features	12
Chapter 2. Installing options	15
Server components	15
I/O board internal connectors and jumpers	16
Memory-card connectors	17
Memory-card LEDs	17
Microprocessor-board connectors and LEDs	18
PCI-X board connectors	19
PCI-X board LEDs	19
SAS-backplane connectors	20
Installation guidelines	21
System reliability guidelines	22
Working inside the server with the power on	22
Handling static-sensitive devices	23
Removing the cover and bezel	23
Installing a hot-swap power supply	24
Installing an adapter	26
Installing a hot-swap hard disk drive	30
Memory module	32
Active Memory	33
Adding and replacing a memory card	35
Installing DIMMs	36
Microprocessor	42
Microprocessor installation order	43
Installing a microprocessor	44
Completing the installation	47
Connecting the cables	48
Updating the server configuration	49
SMP Expansion cabling	49
Chapter 3. Configuring the server	57
Using the Configuration/Setup Utility program	58
Starting the Configuration/Setup Utility program	58
Configuration/Setup Utility menu choices	58
Passwords	62
Using the ServerGuide Setup and Installation CD	63
ServerGuide features	64
Setup and configuration overview	64
Typical operating-system installation	65

Installing your operating system without ServerGuide	65
Using the Boot Menu program	65
Configuring the Gigabit Ethernet controller	66
Using the PXE boot agent utility program	66
Starting the PXE boot agent utility program	66
PXE boot agent utility menu choices	66
Installing and using the baseboard management controller utility programs	67
Enabling and configuring SOL using the OSA SMBridge management utility program	68
Installing the OSA SMBridge management utility program	76
Using the baseboard management controller utility programs	77
Using the SAS/SATA Configuration Utility program	79
Starting the SAS/SATA Configuration Utility program	79
SerialSelect Utility menu choices	79
Disk Utilities	79
Using ServeRAID Manager	79
Configuring the controller	80
Viewing the configuration	81
Using the Scalable Partition Web Interface.	81
Creating a scalable partition	81
Deleting a scalable partition	85
Chapter 4. Updating IBM Director	87
Appendix. Notices	89
Trademarks	89
Important notes.	90
Product recycling and disposal	91
Index	93

Safety

Before installing this product, read the Safety Information.

قبل تركيب هذا المنتج، يجب قراءة الملاحظات الأمنية

Antes de instalar este produto, leia as Informações de Segurança.

在安装本产品之前，请仔细阅读 **Safety Information** (安全信息)。

安裝本產品之前，請先閱讀「安全資訊」。

Prije instalacije ovog produkta obavezno pročitajte Sigurnosne Upute.

Před instalací tohoto produktu si přečtěte příručku bezpečnostních instrukcí.

Læs sikkerhedsforskrifterne, før du installerer dette produkt.

Lees voordat u dit product installeert eerst de veiligheidsvoorschriften.

Ennen kuin asennat tämän tuotteen, lue turvaohjeet kohdasta Safety Information.

Avant d'installer ce produit, lisez les consignes de sécurité.

Vor der Installation dieses Produkts die Sicherheitshinweise lesen.

Πριν εγκαταστήσετε το προϊόν αυτό, διαβάστε τις πληροφορίες ασφάλειας (safety information).

לפני שתתקינו מוצר זה, קראו את הוראות הבטיחות.

A termék telepítése előtt olvassa el a Biztonsági előírásokat!

Prima di installare questo prodotto, leggere le Informazioni sulla Sicurezza.

製品の設置の前に、安全情報をお読みください。

본 제품을 설치하기 전에 안전 정보를 읽으십시오.

Пред да се инсталира овој продукт, прочитајте информацијата за безбедност.

Les sikkerhetsinformasjonen (Safety Information) før du installerer dette produktet.

Przed zainstalowaniem tego produktu, należy zapoznać się z książką "Informacje dotyczące bezpieczeństwa" (Safety Information).

Antes de instalar este produto, leia as Informações sobre Segurança.

Перед установкой продукта прочтите инструкции по технике безопасности.

Pred inštaláciou tohto zariadenia si pečítajte Bezpečnostné predpisy.

Pred namestitvijo tega proizvoda preberite Varnostne informacije.

Antes de instalar este producto, lea la información de seguridad.

Läs säkerhetsinformationen innan du installerar den här produkten.

Important:

All caution and danger statements in this documentation begin with a number. This number is used to cross reference an English caution or danger statement with translated versions of the caution or danger statement in the *IBM Safety Information* book.

For example, if a caution statement begins with a number 1, translations for that caution statement appear in the *IBM Safety Information* book under statement 1.

Be sure to read all caution and danger statements in this documentation before performing the instructions. Read any additional safety information that comes with the server or optional device before you install the device.

Statement 1:



DANGER

Electrical current from power, telephone, and communication cables is hazardous.

To avoid a shock hazard:

- **Do not connect or disconnect any cables or perform installation, maintenance, or reconfiguration of this product during an electrical storm.**
- **Connect all power cords to a properly wired and grounded electrical outlet.**
- **Connect to properly wired outlets any equipment that will be attached to this product.**
- **When possible, use one hand only to connect or disconnect signal cables.**
- **Never turn on any equipment when there is evidence of fire, water, or structural damage.**
- **Disconnect the attached power cords, telecommunications systems, networks, and modems before you open the device covers, unless instructed otherwise in the installation and configuration procedures.**
- **Connect and disconnect cables as described in the following table when installing, moving, or opening covers on this product or attached devices.**

To Connect:

1. Turn everything OFF.
2. First, attach all cables to devices.
3. Attach signal cables to connectors.
4. Attach power cords to outlet.
5. Turn device ON.

To Disconnect:

1. Turn everything OFF.
2. First, remove power cords from outlet.
3. Remove signal cables from connectors.
4. Remove all cables from devices.

Statement 2:



CAUTION:

When replacing the lithium battery, use only IBM Part Number 33F8354 or an equivalent type battery recommended by the manufacturer. If your system has a module containing a lithium battery, replace it only with the same module type made by the same manufacturer. The battery contains lithium and can explode if not properly used, handled, or disposed of.

Do not:

- Throw or immerse into water
- Heat to more than 100°C (212°F)
- Repair or disassemble

Dispose of the battery as required by local ordinances or regulations.

Statement 3:



CAUTION:

When laser products (such as CD-ROMs, DVD drives, fiber optic devices, or transmitters) are installed, note the following:

- Do not remove the covers. Removing the covers of the laser product could result in exposure to hazardous laser radiation. There are no serviceable parts inside the device.
- Use of controls or adjustments or performance of procedures other than those specified herein might result in hazardous radiation exposure.



DANGER

Some laser products contain an embedded Class 3A or Class 3B laser diode. Note the following.

Laser radiation when open. Do not stare into the beam, do not view directly with optical instruments, and avoid direct exposure to the beam.

Statement 4:

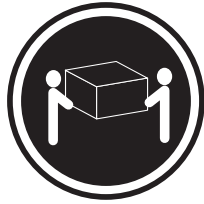

≥ 18 kg (39.7 lb)



≥ 32 kg (70.5 lb)

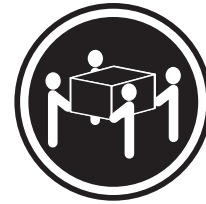

≥ 55 kg (121.2 lb)

CAUTION:
Use safe practices when lifting.

Statement 5:



CAUTION:
The power control button on the device and the power switch on the power supply do not turn off the electrical current supplied to the device. The device also might have more than one power cord. To remove all electrical current from the device, ensure that all power cords are disconnected from the power source.

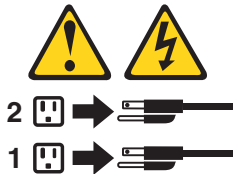

Statement 8:



CAUTION:

Never remove the cover on a power supply or any part that has the following label attached.



Hazardous voltage, current, and energy levels are present inside any component that has this label attached. There are no serviceable parts inside these components. If you suspect a problem with one of these parts, contact a service technician.

Statement 26:



CAUTION:

Do not place any object on top of rack-mounted devices.



Chapter 1. The System x3950 and System x3950 E server

The IBM® System x3950 Type 8878 server is a 3-U¹-high, high-performance server. It is ideally suited for networking environments that require superior microprocessor performance, efficient asset management, flexibility, and large amounts of reliable data storage.

The System x3950 E server comes without a microprocessor or memory, but you can install the components to make the System x3950 E server functionally identical to the System x3950 server. You can interconnect System x3950 and System x3950 E servers to create multi-node configurations using two, four, or eight nodes, for up to 32-way operation. A System x3950 server must serve as the primary node in the multi-node configuration.

Performance, ease of use, reliability, and expansion capabilities were key considerations in the design of the server. These design features make it possible for you to customize the system hardware to meet your needs today and provide flexible expansion capabilities for the future.

The server comes with a limited warranty. For information about the terms of the warranty and getting service and assistance, see the *Warranty and Support Information* document.

The server contains IBM Enterprise X-Architecture™ technologies, which help increase performance and reliability. For more information, see “What your server offers” on page 5 and “Reliability, availability, and serviceability” on page 7.

You can obtain up-to-date information about the server and other IBM server products at <http://www.ibm.com/systems/x/>.

Related documentation

This *User's Guide* contains general information about the server, including how to install supported options and how to configure the server. The following documentation also comes with the server:

- *Installation Guide*

This printed document contains instructions for setting up the server and basic instructions for installing some options.

- *Warranty and Support Information*

This document is in Portable Document Format (PDF) on the IBM *System x™ Documentation* CD. It contains information about the terms of the warranty and about service and assistance.

- *Safety Information*

This document is in PDF on the IBM *System x Documentation* CD. It contains translated caution and danger statements. Each caution and danger statement that appears in the documentation has a number that you can use to locate the corresponding statement in your language in the *Safety Information* document.

- *Rack Installation Instructions*

This printed document contains instructions for installing the server in a rack.

1. Racks are measured in vertical increments of 4.45 cm (1.75 inches) each. Each increment is called a “U.” A 1-U-high device is 1.75 inches tall.

- *Problem Determination and Service Guide*

This document is in PDF on the IBM *System x Documentation* CD. It contains information to help you solve problems yourself, and it contains information for service technicians.

Depending on the server model, additional documentation might be included on the IBM *System x Documentation* CD.

The System x and xSeries® Tools Center is an online information center that contains information about tools for updating, managing, and deploying firmware, device drivers, and operating systems. The System x and xSeries Tools Center is at <http://publib.boulder.ibm.com/infocenter/toolsctr/v1r0/index.jsp>.

The server might have features that are not described in the documentation that comes with the server. The documentation might be updated occasionally to include information about those features, or technical updates might be available to provide additional information that is not included in the server documentation. These updates are available from the IBM Web site. To check for updated documentation and technical updates, complete the following steps.

Note: Changes are made periodically to the IBM Web site. The actual procedure might vary slightly from what is described in this document.

1. Go to <http://www.ibm.com/servers/eserver/support/xseries/index.html>.
2. From the **Hardware** list, select **System x3950** or **System x3950 E** and click **Go**.
3. Click the **Install and use** tab.
4. Click **Product documentation**.

Notices and statements in this document

The caution and danger statements that appear in this document are also in the multilingual *Safety Information* document, which is on the IBM *System x Documentation* CD. Each statement is numbered for reference to the corresponding statement in the *Safety Information* document.

The following notices and statements are used in this document:

- **Note:** These notices provide important tips, guidance, or advice.
- **Important:** These notices provide information or advice that might help you avoid inconvenient or problem situations.
- **Attention:** These notices indicate potential damage to programs, devices, or data. An attention notice is placed just before the instruction or situation in which damage could occur.
- **Caution:** These statements indicate situations that can be potentially hazardous to you. A caution statement is placed just before the description of a potentially hazardous procedure step or situation.
- **Danger:** These statements indicate situations that can be potentially lethal or extremely hazardous to you. A danger statement is placed just before the description of a potentially lethal or extremely hazardous procedure step or situation.

Features and specifications

The following information is a summary of the features and specifications of the server. Depending on the server model, some features might not be available, or some specifications might not apply.

Notes:

1. Racks are marked in vertical increments of 4.45 cm (1.75 inches). Each increment is referred to as a unit, or “U.” A 1-U-high device is 4.45 cm (1.75 inches) tall.
2. Power consumption and heat output vary depending on the number and type of optional features installed and the power-management optional features in use.
3. These levels were measured in controlled acoustical environments according to the procedures specified by the American National Standards Institute (ANSI) S12.10 and ISO 7779 and are reported in accordance with ISO 9296. Actual sound-pressure levels in a given location might exceed the average values stated because of room reflections and other nearby noise sources. The declared sound-power levels indicate an upper limit, below which a large number of computers will operate.

Table 1. Features and specifications

<p>Microprocessor (not standard on System x3950 E models):</p> <ul style="list-style-type: none"> • Intel® Xeon™ MP • 1 MB (minimum) Level-2 cache • 4 MB or 8 MB Level-3 cache • 667 MHz front-side bus (FSB) • Support for up to four microprocessors <p>Note: Use the Configuration/Setup Utility program to determine the type and speed of the microprocessors.</p> <p>Memory (not standard on System x3950 E models):</p> <ul style="list-style-type: none"> • Minimum: 2 GB depending on server model, expandable to 64 GB • Type: 333 MHz, registered, ECC, PC2-3200 double data rate (DDR) II, SDRAM • Sizes: 1 GB, 2 GB, or 4 GB in pairs • Connectors: Two-way interleaved, four dual inline memory module (DIMM) connectors per memory card • Maximum: Four memory cards, each card containing two pairs of PC2-3200 DDRII DIMMs <p>Drives:</p> <ul style="list-style-type: none"> • Slim DVD-ROM: IDE • Serial Attached SCSI (SAS) hard disk drives <p>Expansion bays:</p> <ul style="list-style-type: none"> • Six SAS, 2.5-inch bays • One 12.7-mm removable-media drive bay (DVD drive installed, standard on some models only) <p>Expansion slots:</p> <p>Six PCI-X 2.0 hot-plug 266 MHz/64-bit slots</p> <p>Upgradeable microcode:</p> <p>System BIOS, diagnostics, service processor, BMC, and SAS microcode</p>	<p>Power supply:</p> <ul style="list-style-type: none"> • Standard: Two dual-rated power supplies <ul style="list-style-type: none"> – 1300 watts at 220 V ac input – 650 watts at 110 V ac input • Hot-swappable at 220 V ac only <p>Size:</p> <ul style="list-style-type: none"> • 3U • Height: 128.35 mm (5.05 in.) • Depth: 715 mm (28.15 in.) • Width: 440 mm (17.32 in.) • Weight: approximately 38.5 kg (85 lb) when fully configured or 31.75 kg (70 lb) minimum <p>Integrated functions:</p> <ul style="list-style-type: none"> • Baseboard management controller • IBM EXA-32 Chipset with integrated memory and I/O controller • Service processor support for Remote Supervisor Adapter II SlimLine • Light path diagnostics • Three Universal Serial Bus (USB) ports (2.0) <ul style="list-style-type: none"> – Two on rear of server – One on front of server • Broadcom 5704C dual 10/100/1000 Gigabit Ethernet controllers • ATI 7000-M video <ul style="list-style-type: none"> – 16 MB video memory – SVGA compatible • Mouse connector • Keyboard connector • Serial connector • SMP Expansion Ports <p>Acoustical noise emissions:</p> <ul style="list-style-type: none"> • Sound power, idle: 6.6 bel declared • Sound power, operating: 6.6 bel declared 	<p>Environment:</p> <ul style="list-style-type: none"> • Air temperature: <ul style="list-style-type: none"> – Server on: <ul style="list-style-type: none"> - 10° to 35°C (50° to 95°F); altitude: 0 to 914 m (3000 ft). If the server has a dual-core microprocessor, at maximum power reduce the 35°C by 1°C per 300 m above sea level, or the microprocessor might throttle to remain within the internal thermal specifications. - 10 to 32°C (50° to 90°F); altitude: 914 m to 2133 m (7000 ft). – Server off: 10° to 43°C (50.0° to 109.4°F); maximum altitude: 2133 m (6998.0 ft) • Humidity: <ul style="list-style-type: none"> – Server on: 8% to 80% – Server off: 8% to 80% <p>Heat output:</p> <p>Approximate heat output in British thermal units (Btu) per hour:</p> <ul style="list-style-type: none"> • Minimum configuration: 1364 Btu (400 watts) per hour • Maximum configuration: 5780 Btu (1700 watts) per hour <p>Electrical input:</p> <ul style="list-style-type: none"> • Sine-wave input (50-60 Hz) required • Input voltage low range: <ul style="list-style-type: none"> – Minimum: 100 V ac – Maximum: 127 V ac • Input voltage high range: <ul style="list-style-type: none"> – Minimum: 200 V ac – Maximum: 240 V ac • Approximate input kilovolt-amperes (kVA): <ul style="list-style-type: none"> – Minimum: 0.40 kVA – Maximum: 1.6 kVA <p>Scalability support:</p> <p>Maximum configuration:</p> <ul style="list-style-type: none"> • Eight nodes • 32-way operation • 128 DIMMs • 48 SAS hard disk drives • 48 PCI-X adapters
--	---	---

What your server offers

The server uses the following features and technologies:

- **Active PCI-X (hot-plug) adapter capabilities**

The server has six hot-plug slots for peripheral component interconnect (PCI-X) adapters. With operating-system support, you can replace a failing hot-plug PCI-X adapter without turning off the server. If the operating system and adapter support the hot-add feature, you can also add a PCI adapter in one of these slots without turning off the server.

- **Baseboard management controller**

The baseboard management controller provides environmental monitoring for the server. If environmental conditions exceed thresholds or if system components fail, the baseboard management controller lights LEDs to help you diagnose the problem and records the errors in the error log. The baseboard management controller is also known as the service processor.

The baseboard management controller also provides remote server management capabilities through the OSA SMBridge management utility program.

- **IBM Director**

IBM Director is a workgroup-hardware-management tool that you can use to centrally manage IBM System x and xSeries servers. For more information, see the IBM Director documentation on the *IBM Director* CD.

- **IBM Enterprise X-Architecture technology**

IBM X-Architecture technology combines proven, innovative IBM designs to make your x86-based server powerful, scalable, and reliable. For more information, see <http://www.ibm.com/servers/eserver/xseries/xarchitecture/enterprise/index.html>.

- **Active™ Memory**

The Active Memory feature improves the reliability of memory through memory mirroring, memory scrubbing, and the Memory ProteXion™ feature.

- **Large system-memory capacity**

The server supports up to 64 GB of system memory. The memory controller supports error correcting code (ECC) for up to 16 industry-standard PC2-3200, 333 megahertz (MHz), 1.8 V, 240-pin, registered, double-data-rate (DDR) II, synchronous dynamic random access memory (SDRAM) dual inline memory modules (DIMMs).

- **Memory ProteXion**

The Memory ProteXion feature provides the equivalent of a hot-spare drive in a RAID array. It is based in the memory controller, and it enables the server to sense when a chip on a DIMM has failed and to route the data around the failed chip.

- **IBM ServerGuide™ Setup and Installation CD**

The *ServerGuide Setup and Installation* CD that comes with the server (standard on some models only) provides programs to help you set up the server and install a 32-bit Windows operating system. The ServerGuide program detects installed hardware options and provides the correct configuration programs and device drivers. For more information about the *ServerGuide Setup and Installation* CD, see “Using the ServerGuide Setup and Installation CD” on page 63.

- **Integrated network support**
The server comes with an integrated Broadcom 5704C dual Gigabit Ethernet controller, which supports connection to a 10-Mbps, 100-Mbps, or 1000-Mbps network. For more information, see “Configuring the Gigabit Ethernet controller” on page 66.
- **Large data-storage capacity and hot-swap capability**
The server supports up to six 25.4-mm (1-inch) slim-high, 2.5-inch hot-swap hard disk drives that are connected to the SAS backplane. With the hot-swap feature, you can add, remove, or replace hard disk drives without turning off the server.
- **Light path diagnostics**
Light path diagnostics provides LEDs to help you diagnose problems. For more information, see the section about light path diagnostics in the *Installation Guide*.
- **PowerExecutive™**
PowerExecutive is an IBM Director extension that measures and reports server power consumption as it occurs. This enables you to monitor power consumption in correlation to specific software application programs and hardware configurations. You can obtain the measurement values through the systems-management interface, and can view them using IBM Director. For more information, including the required levels of IBM Director and PowerExecutive, see the IBM Director documentation on the IBM Director CD, or go to http://www.ibm.com/servers/eserver/xseries/systems_management/ibm_director/extensions.
- **Redundant connection**
The addition of an optional network interface card (NIC) provides a failover capability to a redundant Ethernet connection. If a problem occurs with the primary Ethernet connection, all Ethernet traffic that is associated with the primary connection is automatically switched to the redundant NIC. If the applicable device drivers are installed, this switching occurs without data loss and without user intervention.
- **Redundant cooling and power capabilities**
The redundant cooling of the fans in the server enable continued operation if one of the fans fails. The server supports up to two hot-swap power supplies, which provide redundant power for many server configurations.
- **Scalable partitions**
The server is scalable and can be connected to multiple servers so that you can share resources between servers.
- **ServeRAID™ support**
The server supports ServeRAID adapters to create redundant array of independent disks (RAID) configurations.
- **Symmetric multiprocessing (SMP)**
The server supports up to four Intel Xeon microprocessors. If the server comes with only one microprocessor, you can install additional microprocessors to enhance performance and provide SMP capability.
- **Systems-management capabilities**
The server supports the IBM Remote Supervisor Adapter II SlimLine. When this adapter is used with the systems-management software that comes with the server, you can manage the functions of the server locally and remotely. The Remote Supervisor Adapter II SlimLine also provides system monitoring, event recording, and dial-out alert capability.

Reliability, availability, and serviceability

Three important computer design features are reliability, availability, and serviceability (RAS). The RAS features help to ensure the integrity of the data that is stored in the server, the availability of the server when you need it, and the ease with which you can diagnose and correct problems.

The server has the following RAS features:

- Active memory
- Active™ PCI-X (hot-plug) adapter slots
- Automatic BIOS recovery (ABR)
- Automatic error retry and recovery
- Automatic restart after a power failure
- Availability of microcode and diagnostic levels
- Backup basic input/output system (BIOS) switching under the control of the service processor
- Baseboard management controller (service processor)
- Built-in, menu-driven electrically erasable programmable ROM (EEPROM) based setup, system configuration, and diagnostic programs
- Built-in monitoring for fan, power, temperature, voltage, and power-supply redundancy
- Chipkill™ memory protection
- Error codes and messages
- Error correcting code (ECC) L2 cache and system memory
- Fault-resistant startup
- Hot-swap hard disk drives
- IBM Director workgroup-hardware-management tool
- Information and light path diagnostics LED panels
- Optional service processor adapter for remote system management
- Parity checking on the small computer system interface (SCSI) bus and PCI buses
- Power managed and Advanced Configuration and Power Interface (ACPI) compliant
- Power-on self-test (POST)
- Predictive Failure Analysis® (PFA) alerts
- Redundant Ethernet capabilities (requires optional Ethernet adapter) with failover support
- Redundant hot-swap capability
 - Cooling fans with speed-sensing capability
 - Power supplies
- Remind button to temporarily flash the Attention LED
- Remote system problem-determination support
- ROM-based diagnostic programs
- Standby voltage for systems-management features and monitoring
- Startup (boot) from LAN using Preboot Execution Environment (PXE) protocol
- System auto-configuring from the configuration menu
- System error logging (POST and service processor when Remote Supervisor Adapter II SlimLine is installed)
- Upgradeable microcode for POST, BIOS, diagnostics, service processor, and read-only memory (ROM) resident code, locally or over the LAN
- Vital product data (VPD) on microprocessors, system boards, power supplies, and SAS (hot-swap-drive) backplane
- Wake on LAN® capability

IBM Director

With IBM Director, a network administrator can perform the following tasks:

- View the hardware configuration of remote systems, in detail
- Monitor the usage and performance of critical components, such as microprocessors, disks, and memory
- Centrally manage individual or large groups of IBM and non-IBM x86-processor-based servers, desktop computers, workstations, and notebook computers on a variety of platforms

IBM Director provides a comprehensive entry-level workgroup hardware manager. It includes the following key features:

- Advanced self-management capabilities for maximum system availability.
- Multiple operating-system platform support, including Microsoft® Windows® 2000 Server, Windows Server 2003, Windows XP Professional, AIX®, i5/OS™, Red Hat Linux®, SUSE Linux, VMware, and Novell NetWare. For a complete list of operating systems that support IBM Director, see the IBM Director Compatibility Document. This document is in Portable Document Format (PDF) at <http://www.ibm.com/pc/support/site.wss/document.do?Indocid=MIGR-61788>. It is updated every 6 to 8 weeks.
- Support for IBM and non-IBM servers, desktop computers, workstations, and notebook computers.
- Support for systems-management industry standards.
- Integration into leading workgroup and enterprise systems-management environments.
- Ease of use, training, and setup.

IBM Director also provides an extensible platform that supports advanced server tools that are designed to reduce the total cost of managing and supporting networked systems. By deploying IBM Director, you can achieve reductions in ownership costs through the following benefits:

- Reduced downtime
- Increased productivity of IT personnel and users
- Reduced service and support costs

For more information about IBM Director, see the documentation on the *IBM Director* CD that comes with the server, the IBM Director Information Center at http://publib.boulder.ibm.com/infocenter/eserver/v1r2/topic/dirinfo/fqm0_main.html, and the IBM System x and xSeries Systems Management Web page at http://www.ibm.com/servers/eserver/xseries/systems_management/, which presents an overview of IBM Systems Management and IBM Director.

The UpdateXpress program

The UpdateXpress program is available for most System x and xSeries servers and optional devices. It detects supported and installed device drivers and firmware in the server and installs available updates. You can download the UpdateXpress program from the Web at no additional cost, or you can purchase it on a CD. To download the program or purchase the CD, go to http://www.ibm.com/servers/eserver/xseries/systems_management/ibm_director/extensions/xpress.html. Additional information about UpdateXpress is available from the System x and xSeries Tools Center at <http://publib.boulder.ibm.com/infocenter/toolsctr/v1r0/index.jsp>.

Server controls, connectors, LEDs, and power

This section describes the controls, connectors, and light-emitting diodes (LEDs) and how to turn the server on and off.

Front view

The following illustration shows the controls, LEDs, and connectors on the front of the server.

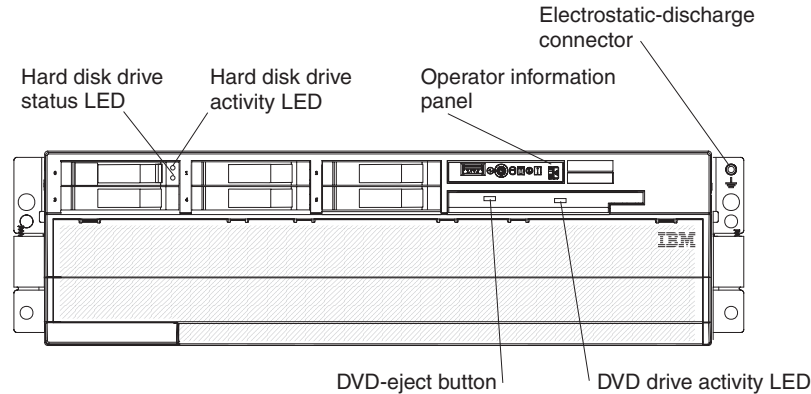

Hard disk drive status LED: If a ServeRAID-8i adapter is installed, when this LED is lit it indicates that the associated hard disk drive has failed. If the LED flashes slowly (one flash per second), the drive is being rebuilt. If the LED flashes rapidly (three flashes per second), the controller is identifying the drive.

Hard disk drive activity LED: On some server models, each hot-swap hard disk drive has an activity LED. When this LED is flashing, it indicates that the drive is in use.

Operator information panel: This panel contains controls and LEDs. The following illustration shows the controls and LEDs on the operator information panel.

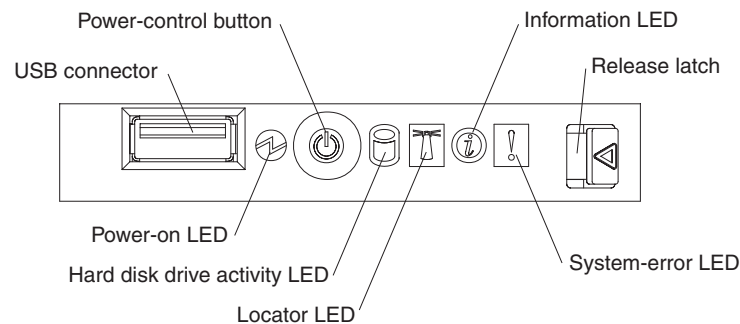

The following controls, connectors, and LEDs are on the operator information panel:

- **USB connector:** Connect a USB device to this connector.
- **Power-control button:** Press this button to turn the server on and off manually. A power-control-button shield comes with the server.
- **Information LED:** When this LED is lit, it indicates that there is a suboptimal condition in the server and that light path diagnostics will light an additional LED to help isolate the condition. If the LOG LED on the light path diagnostics panel is lit, information is available in the baseboard management controller (BMC) log or in the system-event log about the condition. The condition might be that the BMC log is full or almost full.

This LED and LEDs on the light path diagnostics panel remain lit until you resolve the condition. If the only condition is that the BMC log is full or almost full, clear the BMC log or the system-event log through the Configuration/Setup Utility program to turn off the lit LEDs. See “Using the Configuration/Setup Utility program” on page 58 for information about clearing the logs. Clear the logs after you have resolved all conditions.

Important: If the server has a baseboard management controller, clear the BMC log and system-event log after you resolve all conditions. This will turn off the information LED and LOG LED, if all conditions are resolved.

- **Release latch:** Slide this latch to the left to access the light path diagnostics panel.
- **System-error LED:** When this LED is lit, it indicates that a system error has occurred. An LED on the light path diagnostics panel is also lit to help isolate the error.
- **Locator LED:** When this LED is lit, it has been lit remotely by the system administrator to aid in visually locating the server.
In multi-node configurations, when this LED flashes during startup, it indicates that the server is the primary node. When this LED is lit during startup, it indicates that the server is a secondary node.
- **Hard disk drive activity LED:** When this LED is flashing, it indicates that a SAS hard disk drive is in use.
- **Power-on LED:** When this LED is lit and not flashing, it indicates that the server is turned on. When this LED is flashing, it indicates that the server is turned off and still connected to an ac power source. When this LED is off, it indicates that ac power is not present, or the power supply or the LED itself has failed.

Note: If this LED is off, it does not mean that there is no electrical power in the server. The LED might be burned out. To remove all electrical power from the server, you must disconnect the power cords from the electrical outlets.

Electrostatic-discharge connector: Connect an electrostatic-discharge wrist strap to this connector.

DVD drive activity LED: (Standard on some models only) When this LED is lit, it indicates that the DVD drive is in use.

DVD-eject button: (Standard on some models only) Press this button to release a CD or DVD from the DVD drive.

Rear view

The following illustration shows the connectors and LEDs on the rear of the server.

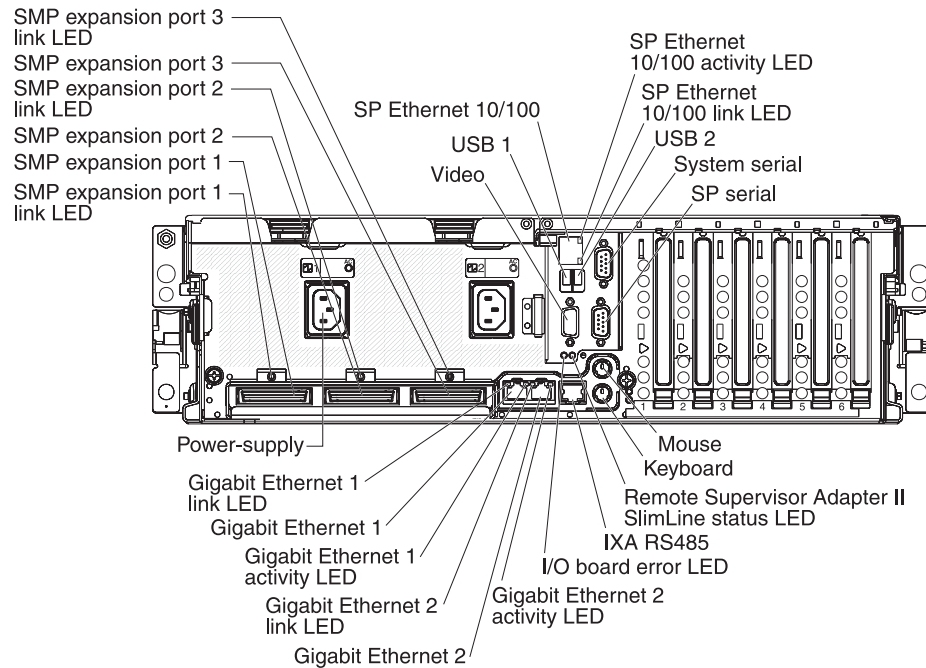

Video connector: Connect a monitor to this connector.

USB 1 connector: Connect a USB device to this connector.

SP Ethernet 10/100 connector: Use this connector to connect the service processor to a network.

SP Ethernet 10/100 activity LED: This LED is on the SP Ethernet 10/100 connector. When this LED is lit, it indicates that there is activity between the server and the network.

SP Ethernet 10/100 link LED: This LED is on the SP Ethernet 10/100 connector. When this LED is lit, it indicates that there is an active connection on the Ethernet port.

USB 2 connector: Connect a USB device to this connector.

System serial connector: Connect a 9-pin serial device to this connector.

SP Serial connector: Connect a 9-pin serial device to this connector.

Mouse connector: Connect a mouse or other device to this connector.

Keyboard connector: Connect a keyboard to this connector.

Remote Supervisor Adapter II SlimLine status LED: When this LED flashes, it indicates that there is activity on the Remote Supervisor Adapter II SlimLine. When this LED is lit continuously, it indicates that there is a problem with the Remote Supervisor Adapter II SlimLine.

IXA RS485 connector: Use this connector to connect to an iSeries™ server when an Integrated xSeries Adapter (IXA) is installed. The cable for this connection comes with the server.

I/O board error LED: This LED is on the I/O board and is visible on the rear of the server. When this LED is lit, it indicates that there is a problem with the I/O board.

Gigabit Ethernet 2 activity LED: This LED is on the Gigabit Ethernet 2 connector. When this LED flashes, it indicates that there is activity between the server and the network.

Gigabit Ethernet 2 connector: Use this connector to connect the server to a network.

Gigabit Ethernet 2 link LED: This LED is on the Gigabit Ethernet 2 connector. When this LED is lit, it indicates that there is an active connection on the Ethernet port.

Gigabit Ethernet 1 activity LED: This LED is on the Gigabit Ethernet 1 connector. When this LED flashes, it indicates that there is activity between the server and the network.

Gigabit Ethernet 1 connector: Use this connector to connect the server to a network.

Gigabit Ethernet 1 link LED: This LED is on the Gigabit Ethernet 1 connector. When this LED is lit, it indicates that there is an active connection on the Ethernet port.

Power-supply connector: Connect the power cord to this connector.

SMP Expansion Port 1 link LED: When this LED is lit, it indicates that there is an active connection on SMP Expansion Port 1.

SMP Expansion Port 1 connector: Use this connector to connect the server to other servers to form multi-node configurations.

SMP Expansion Port 2 connector: Use this connector to connect the server to other servers to form multi-node configurations.

SMP Expansion Port 2 link LED: When this LED is lit, it indicates that there is an active connection on SMP Expansion Port 2.

SMP Expansion Port 3 connector: Use this connector to connect the server to other servers to form multi-node configurations.

SMP Expansion Port 3 link LED: When this LED is lit, it indicates that there is an active connection on SMP Expansion Port 3.

Server power features

When the server is connected to an ac power source but is not turned on, the operating system does not run, and all core logic except for the service processor is shut down; however, the server can respond to requests from the service processor, such as a remote request to turn on the server. The power-on LED flashes to indicate that the server is connected to ac power but not turned on.

Turning on the server

Approximately 20 seconds after the server is connected to ac power, the power-control button becomes active, and one or more fans might start running to provide cooling while the server is connected to power. You can turn on the server and start the operating system by pressing the power-control button.

Note: If a Remote Supervisor Adapter II SlimLine is installed in the server, during initial startup, the server might appear to be unresponsive for an unusual length of time (one minute to several minutes).

The server can also be turned on in any of the following ways:

- If a power failure occurs while the server is turned on, the server will restart automatically when power is restored.
- If the server is installed in a static partition, you can turn on the server and start the operating system by pressing the power-control button on the primary node in the partition.
- If your operating system supports the systems-management software for the Remote Supervisor Adapter II SlimLine, the systems-management software can turn on the server.
- If your operating system supports the Wake on LAN feature, the Wake on LAN feature can turn on the server.

Note: When 4 GB or more of memory (physical or logical) is installed, some memory is reserved for various system resources and is unavailable to the operating system. The amount of memory that is reserved for system resources depends on the operating system, the configuration of the server, and the configured PCI options.

Turning off the server

When you turn off the server and leave it connected to ac power, the server can respond to requests from the service processor, such as a remote request to turn on the server. While the server remains connected to ac power, one or more fans might continue to run. To remove all power from the server, you must disconnect it from the power source.

Some operating systems require an orderly shutdown before you turn off the server. See your operating-system documentation for information about shutting down the operating system.

Statement 5:



CAUTION:

The power control button on the device and the power switch on the power supply do not turn off the electrical current supplied to the device. The device also might have more than one power cord. To remove all electrical current from the device, ensure that all power cords are disconnected from the power source.

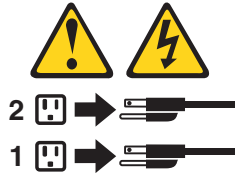

The server can be turned off in any of the following ways:

- You can turn off the server from the operating system, if your operating system supports this feature. After an orderly shutdown of the operating system, the server will be turned off automatically.
- You can press the power-control button to start an orderly shutdown of the operating system and turn off the server, if your operating system supports this feature.
- If the operating system stops functioning, you can press and hold the power-control button for more than 4 seconds to turn off the server.
- If the server is installed in a static partition, pressing the power-control button on the primary node in the partition will start an orderly shutdown of the operating system and turn off the server.
- The server can be turned off from the Remote Supervisor Adapter II SlimLine user interface.
- If the Wake on LAN feature turned on the server, the Wake on LAN feature can turn off the server.
- You can turn off the server through a request from the service processor.

Chapter 2. Installing options

This chapter provides detailed instructions for installing optional hardware devices in the server.

Server components

The following illustration shows the major components in the server. The illustrations in this document might differ slightly from your hardware.

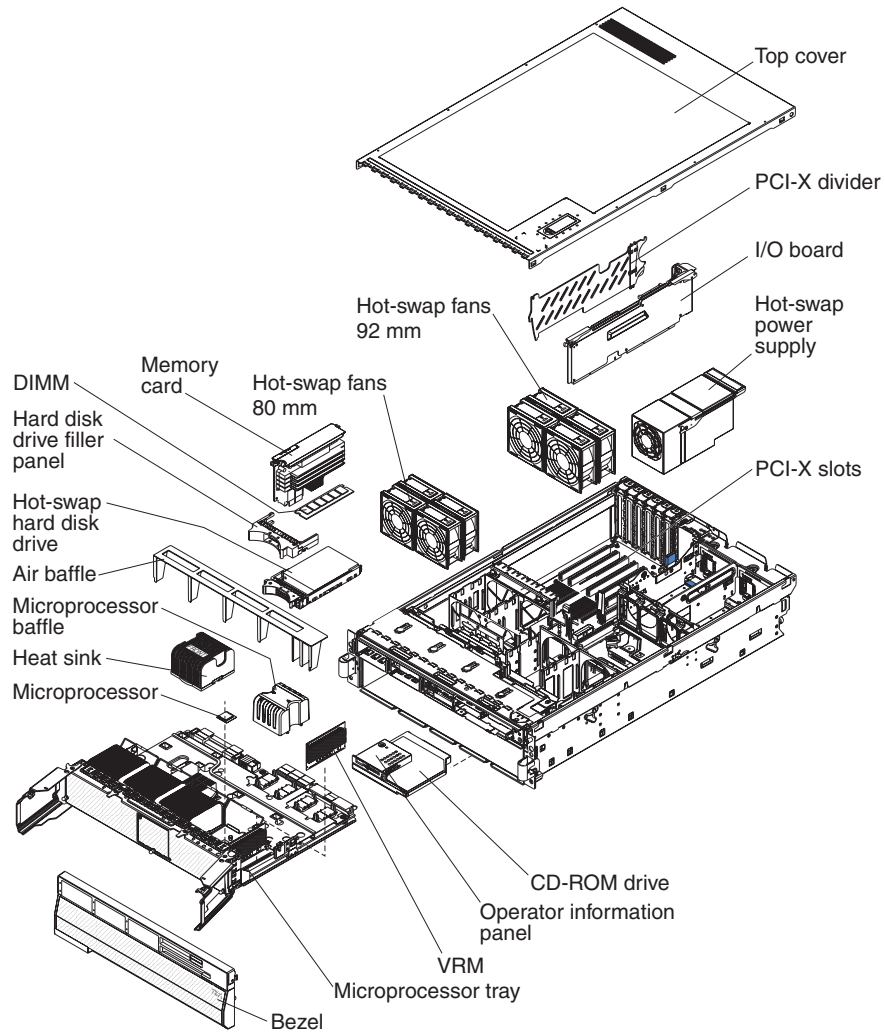

I/O board internal connectors and jumpers

The following illustration shows the internal connectors and jumpers on the I/O board.

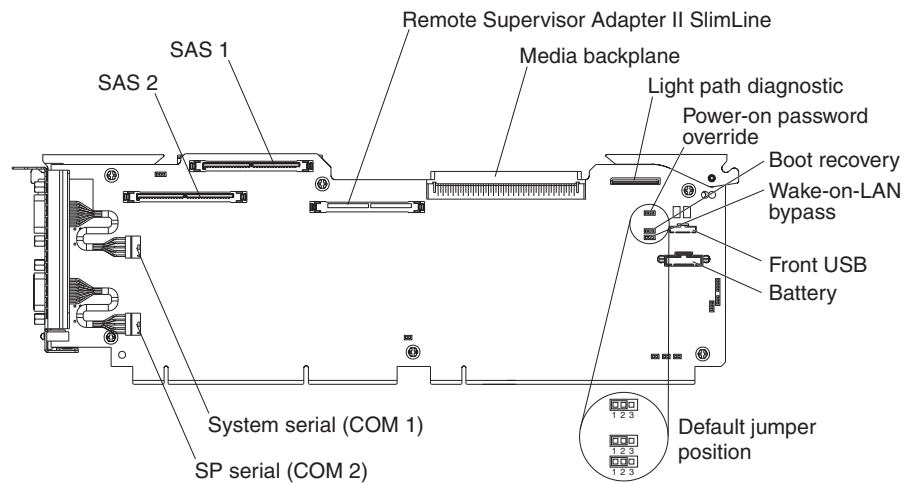

Table 2 describes the function of each three-pin jumper block.

Table 2. I/O board jumper blocks

Jumper name	Description
Power-on password override (J9)	<p>The default position is pins 1 and 2. Change the position of this jumper to pins 2 and 3 to bypass the power-on password check.</p> <p>Changing the position of this jumper does not affect the administrator password check if an administrator password is set. If the administrator password is lost, the operator information panel must be replaced.</p> <p>For more information about passwords, see “Passwords” on page 62.</p>
Boot recovery (BIOS) (J14)	<p>The default position is pins 1 and 2 (use the primary page during startup). Move the jumper to pins 2 and 3 to use the secondary page during startup.</p>
Wake on LAN [®] bypass (J15)	<p>The default position is pins 1 and 2. Move the jumper to pins 2 and 3 to prevent a Wake on LAN packet from waking the system when the system is in the powered-off state.</p>

Memory-card connectors

The following illustration shows the connectors on the memory card.

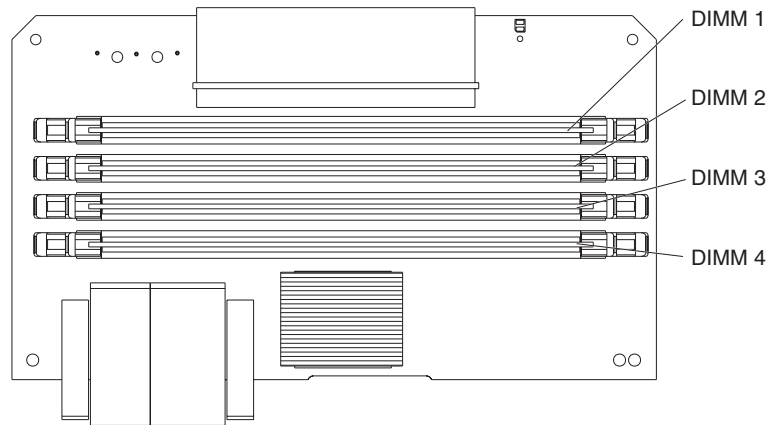

Memory-card LEDs

The following illustration shows the LEDs on the memory card.

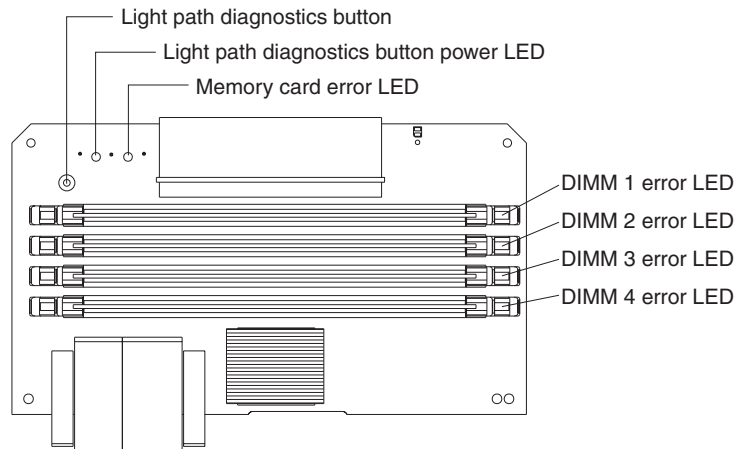

The following illustration shows the top view of the memory card.

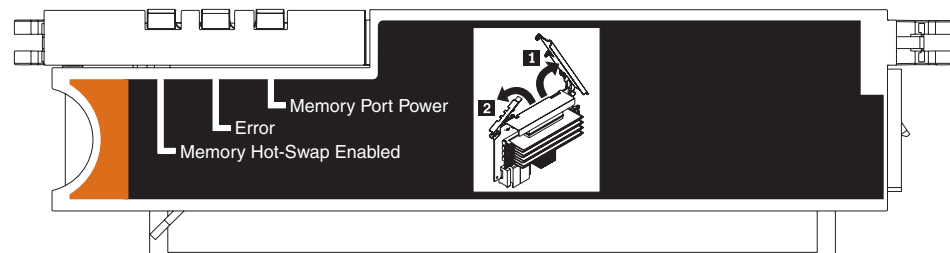

Microprocessor-board connectors and LEDs

The following illustration shows the connectors and LEDs on the microprocessor board.

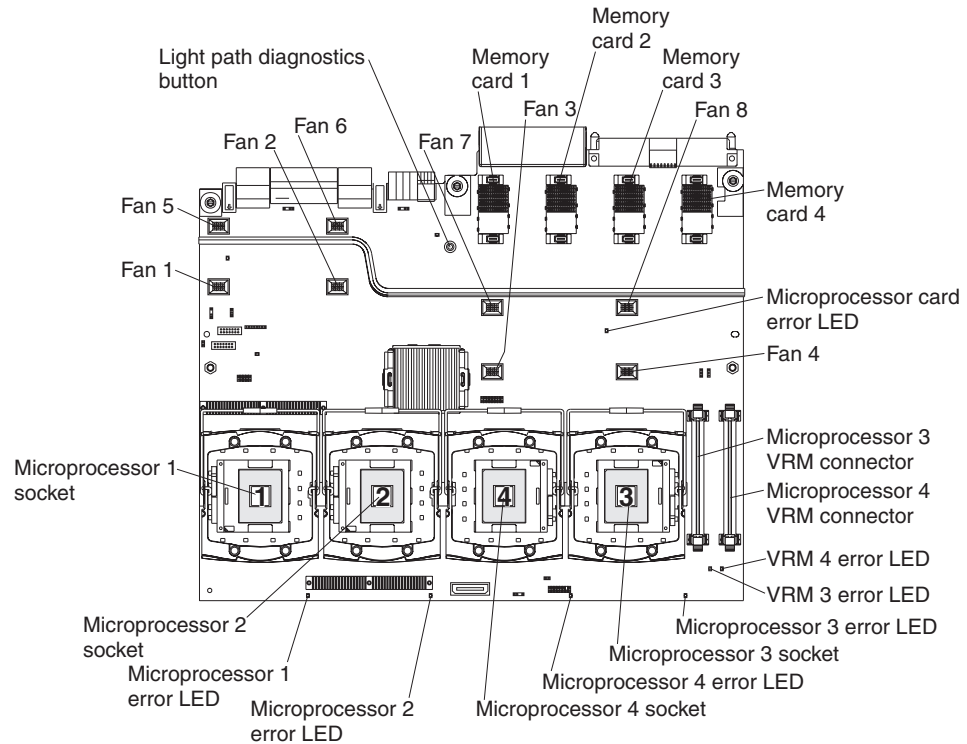

PCI-X board connectors

The following illustration shows the connectors on the PCI-X board.

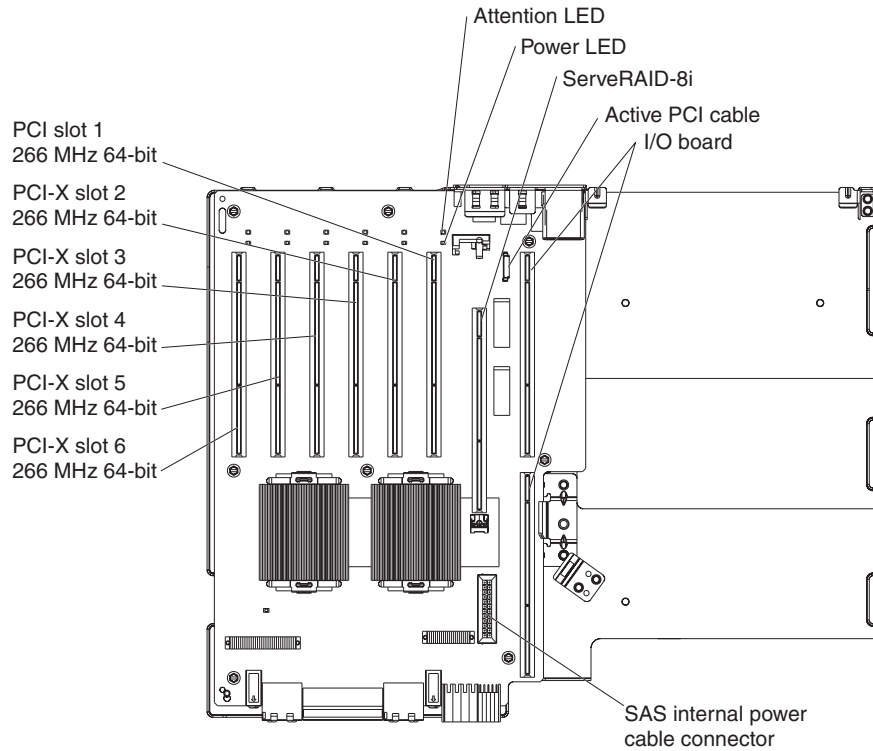

PCI-X board LEDs

The following illustration shows the LEDs on the PCI-X board.

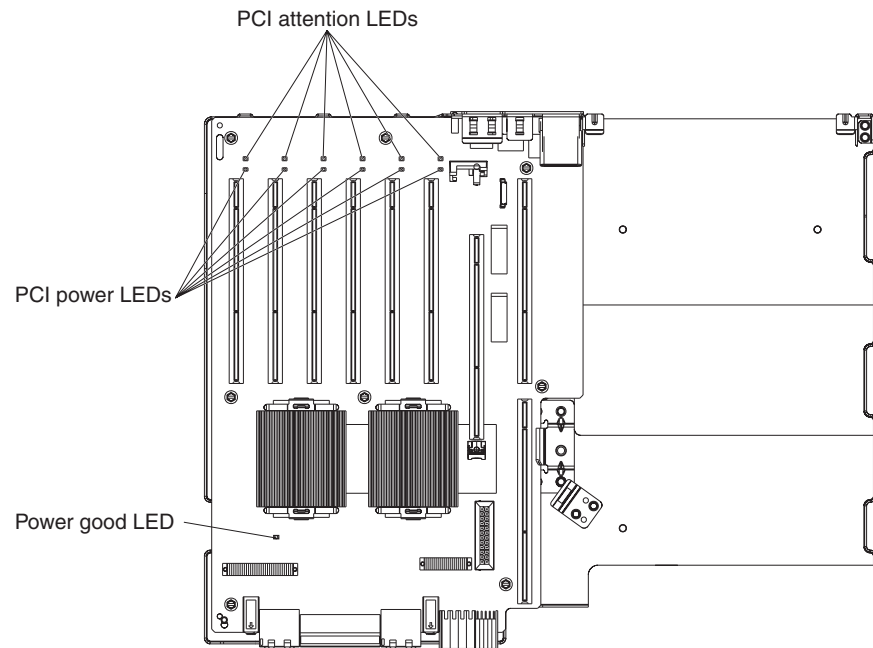

SAS-backplane connectors

The following illustration shows the connectors on the SAS backplane.

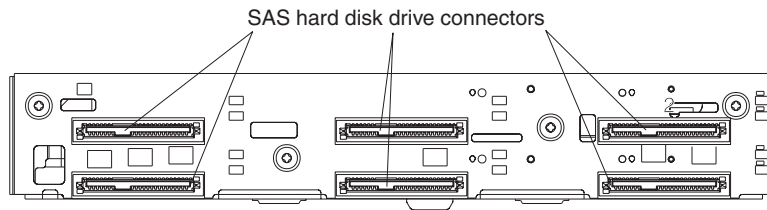

Front of SAS backplane

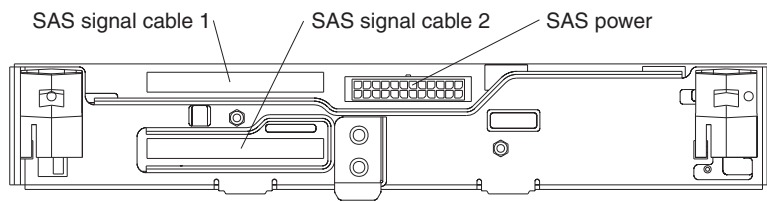

Back of SAS backplane

Installation guidelines

Before you install options, read the following information:

- Read the safety information that begins on page v, the guidelines in “Working inside the server with the power on” on page 22, and “Handling static-sensitive devices” on page 23. This information will help you work safely.
- When you install your new server, take the opportunity to download and apply the most recent firmware updates. This step will help to ensure that any known issues are addressed and that your server is ready to function at maximum levels of performance. To download firmware updates for your server, go to <http://www.ibm.com/servers/eserver/support/xseries/index.html>, select **System x3950** or **System x3950 E** from the **Hardware** list, click **Go**, and then click the **Download** tab. For additional information about tools for updating, managing, and deploying firmware, see the System x and xSeries Tools Center at <http://publib.boulder.ibm.com/infocenter/toolsctr/v1r0/index.jsp>.
- Before you install optional hardware devices, make sure that the server is working correctly. Start the server, and make sure that the operating system starts, if an operating system is installed, or that a 19990305 error code is displayed, indicating that an operating system was not found but the server is otherwise working correctly. If the server is not working correctly, see “Solving Problems” in the *Installation Guide* for diagnostic information.
- Observe good housekeeping in the area where you are working. Place removed covers and other parts in a safe place.
- If you must start the server while the cover is removed, make sure that no one is near the server and that no tools or other objects have been left inside the server.
- Do not attempt to lift an object that you think is too heavy for you. If you have to lift a heavy object, observe the following precautions:
 - Make sure that you can stand safely without slipping.
 - Distribute the weight of the object equally between your feet.
 - Use a slow lifting force. Never move suddenly or twist when you lift a heavy object.
 - To avoid straining the muscles in your back, lift by standing or by pushing up with your leg muscles.
- Make sure that you have an adequate number of properly grounded electrical outlets for the server, monitor, and other devices.
- Back up all important data before you make changes to disk drives.
- Have a small flat-blade screwdriver available.
- You do not have to turn off the server to install or replace hot-swap power supplies, hot-swap fans, hot-plug adapters, or hot-plug Universal Serial Bus (USB) devices. However, you must turn off the server before you perform any steps that involve removing or installing adapter cables.
- Blue on a component indicates touch points, where you can grip the component to remove it from or install it in the server, open or close a latch, and so on.
- Orange on a component or an orange label on or near a component indicates that the component can be hot-swapped, which means that if the server and operating system support hot-swap capability, you can remove or install the component while the server is running. (Orange can also indicate touch points on hot-swap components.) See the instructions for removing or installing a specific hot-swap component for any additional procedures that you might have to perform before you remove or install the component.

- When you are finished working on the server, reinstall all safety shields, guards, labels, and ground wires.
- For a list of supported optional devices for the server, see <http://www.ibm.com/servers/eserver/serverproven/compat/us/>.

System reliability guidelines

To help ensure proper system cooling and system reliability, make sure that the following requirements are met:

- Each of the drive bays has a drive or a filler panel and electromagnetic compatibility (EMC) shield installed in it.
- There is adequate space around the server to allow the server cooling system to work properly. Leave approximately 50 mm (2 in.) of open space around the front and rear of the server. Do not place objects in front of the fans. For proper cooling and airflow, replace the server cover before turning on the server. Operating the server for extended periods of time (more than 30 minutes) with the server cover removed might damage server components.
- If the server has redundant power, each of the power-supply bays has a power supply installed in it.
- You have followed the cabling instructions that come with optional adapters.
- You have replaced a failed fan as soon as possible.
- You have replaced a hot-swap drive within 2 minutes of removal.
- You do not run the server without the air baffle installed. Operating the server without the air baffle might cause the microprocessor or microprocessors to overheat.
- Microprocessor sockets 2, 3, and 4 each always contain either a microprocessor baffle or a microprocessor and heat sink.
- For redundant and hot-swappable operation, the power supplies are connected to 200-240 V ac.

Working inside the server with the power on

Attention: Static electricity that is released to internal server components when the server is powered-on might cause the server to halt, which could result in the loss of data. To avoid this potential problem, always use an electrostatic-discharge wrist strap or other grounding system when working inside the server with the power on.

The server supports hot-plug, hot-add, and hot-swap devices and is designed to operate safely while it is turned on and the cover is removed. Follow these guidelines when you work inside a server that is turned on:

- Avoid wearing loose-fitting clothing on your forearms. Button long-sleeved shirts before working inside the server; do not wear cuff links while you are working inside the server.
- Do not allow your necktie or scarf to hang inside the server.
- Remove jewelry, such as bracelets, necklaces, rings, and loose-fitting wrist watches.
- Remove items from your shirt pocket, such as pens and pencils, that could fall into the server as you lean over it.
- Avoid dropping any metallic objects, such as paper clips, hairpins, and screws, into the server.

Handling static-sensitive devices

Attention: Static electricity can damage the server and other electronic devices. To avoid damage, keep static-sensitive devices in their static-protective packages until you are ready to install them.

To reduce the possibility of damage from electrostatic discharge, observe the following precautions:

- Limit your movement. Movement can cause static electricity to build up around you.
- The use of a grounding system is recommended. For example, wear an electrostatic-discharge wrist strap, if one is available. Always use an electrostatic-discharge wrist strap or other grounding system when working inside the server with the power on.
- Handle the device carefully, holding it by its edges or its frame.
- Do not touch solder joints, pins, or exposed circuitry.
- Do not leave the device where others can handle and damage it.
- While the device is still in its static-protective package, touch it to an unpainted metal part on the outside of the server for at least 2 seconds. This drains static electricity from the package and from your body.
- Remove the device from its package and install it directly into the server without setting down the device. If it is necessary to set down the device, put it back into its static-protective package. Do not place the device on the server cover or on a metal surface.
- Take additional care when handling devices during cold weather. Heating reduces indoor humidity and increases static electricity.

Removing the cover and bezel

To remove the cover and bezel, complete the following steps:

1. Read the safety information that begins on page v and “Installation guidelines” on page 21.
2. If you are installing or replacing a non-hot-swap component, turn off the server and all attached peripheral devices. Disconnect all power cords; then, disconnect all external signal cables from the server.
3. Slide the server out of the rack until the slide rails lock into place.

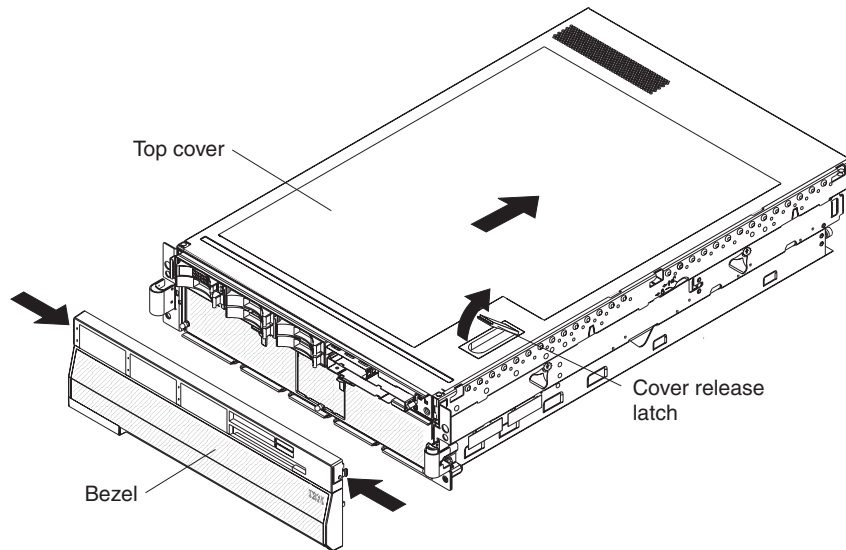

4. Lift the cover-release latch. The cover slides to the rear approximately 13 mm (0.5 inch). Lift the cover off the server.

Attention: For proper cooling and airflow, replace the top cover before turning on the server. Operating the server for more than 2 minutes with the top cover removed might damage server components.

5. Press on the bezel retention tabs at the top edge of the bezel, and pull the top of the bezel slightly away from the server.
6. Lift the bezel up to release the two tabs at the bottom edge of the bezel.

Installing a hot-swap power supply

The following notes describe information that you must consider when installing a hot-swap power supply in the server:

- The server comes with a minimum of one power supply and supports up to two power supplies (hot-swappable at 220 V ac only).
- The power supplies are numbered from left to right (1 and 2) as viewed from the rear of the server. Power supplies must be installed in the following sequence: power supply 1, then power supply 2.
- A single 110 V ac power supply can support a maximum configuration of one microprocessor, two PCI-X adapters, three hard disk drives, and four DIMMs. If you exceed this configuration you must either install a second power supply or use 220 V ac input.
- If you install or remove a power supply, observe the following precautions:

Statement 8:



CAUTION:

Never remove the cover on a power supply or any part that has the following label attached.



Hazardous voltage, current, and energy levels are present inside any component that has this label attached. There are no serviceable parts inside these components. If you suspect a problem with one of these parts, contact a service technician.

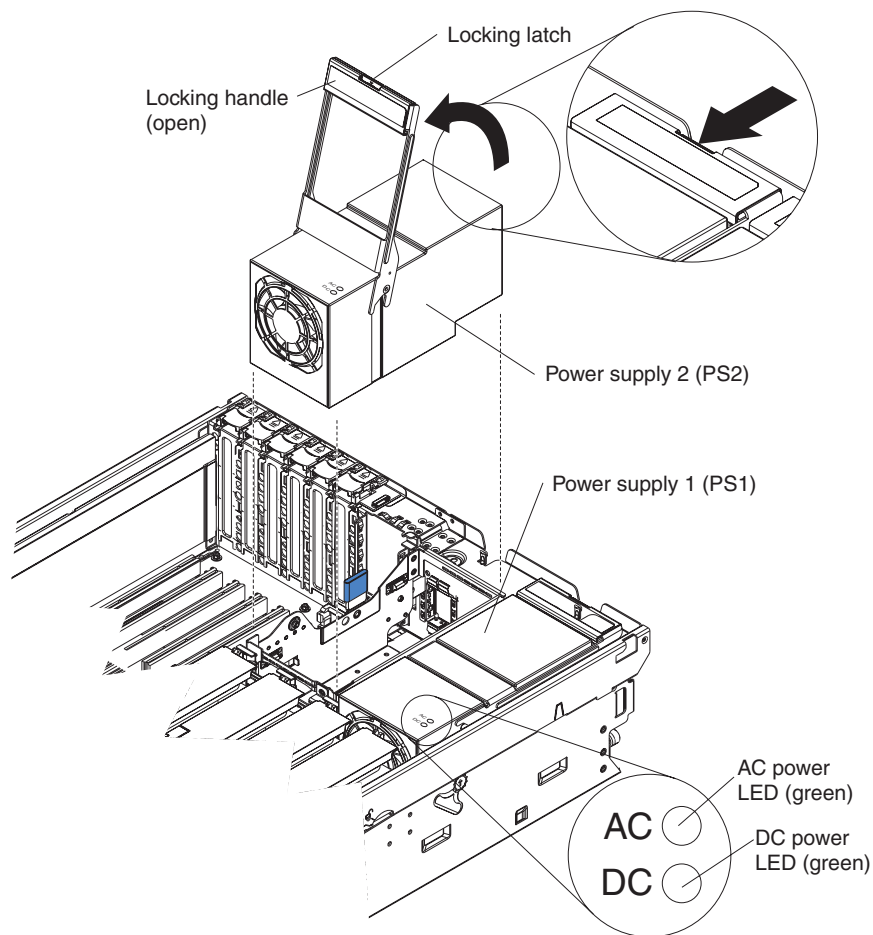

To remove a hot-swap power supply, complete the following steps:

1. Read the safety information that begins on page v and “Installation guidelines” on page 21.

Attention: Static electricity that is released to internal server components when the server is powered-on might cause the server to halt, which could result in the loss of data. To avoid this potential problem, always use an electrostatic-discharge wrist strap or other grounding system when working inside the server with the power on.

2. Remove the server cover. See “Removing the cover and bezel” on page 23.

3. If you are adding a power supply to an empty power-supply bay, remove the cover from the ac power connector opening on the rear of the server.
4. If you are replacing a failed power supply, remove the failed power supply from the bay:
 - a. Disconnect the power cord from the connector on the back of the failed power supply.
 - b. Press the locking latch on the power-supply handle and raise the power-supply handle to the open position.
 - c. Lift the failed power supply out of the bay.
5. Raise the handle on the new power supply to the open position.
6. Place the new power supply into the power-supply bay in the chassis and fully close the locking handle.
7. Connect one end of the power cord for the new power supply into the connector on the back of the power supply; route the power cord through the cable-management arm and connect the other end of the power cord into a properly grounded electrical outlet.
8. Make sure that the ac power LED on the rear of the power supply and the ac power LED on the top of the power supply are lit, indicating that the power supply is operating correctly. If the server is turned on, make sure that the dc power LED on the top of the power supply is lit also.

If you have other options to install or remove, do so now; otherwise, go to “Completing the installation” on page 47.

Installing an adapter

The following notes describe the types of adapters that the server supports and other information that you must consider when installing an adapter:

- Locate the documentation that comes with the adapter and follow those instructions in addition to the instructions in this section. If you must change the switch setting or jumper settings on the adapter, follow the instructions that come with the adapter.
- See the documentation that comes with the operating system for information about enabling a hot-plug PCI-X slot.
- Avoid touching the components and gold-edge connectors on the adapter.
- The server supports full-length and half-length, 266 MHz or slower, 3.3 V, 32-bit or 64-bit PCI and PCI-X adapters.
- The server scans devices and PCI-X slots to assign system resources in the following order: integrated Ethernet controller, integrated SAS controller, and then PCI and PCI-X slots 1 through 6.

Note: To change the order in which the server scans devices and PCI-X slots, start the Configuration/Setup Utility program and select **Start Options** from the main menu. See “Using the Configuration/Setup Utility program” on page 58 for details about using the Configuration/Setup Utility program.

- You do not have to turn off the server to install a hot-plug adapter in any of the PCI-X slots. However, you must turn off the server when performing any steps that involve installing or removing cables.
- The optional Integrated xSeries Adapter (IXA) can be installed only in slot 2. You must move jumpers J35 and J40 on the IXA. For details about installing the IXA, see the documentation that comes with the adapter.

- An optional ServeRAID-8i adapter can be installed only in its dedicated connector on the PCI-X board. See the following illustration for the location of the connector on the PCI-X board. The ServeRAID-8i adapter is not cabled to the server and no rerouting of the SAS cables is required.

Notes:

1. The blue handle that comes with the adapter is required to install the adapter.
2. In multi-node configurations, only two nodes can contain a ServeRAID-8i adapter.

To install the ServeRAID-8i adapter, complete the following steps:

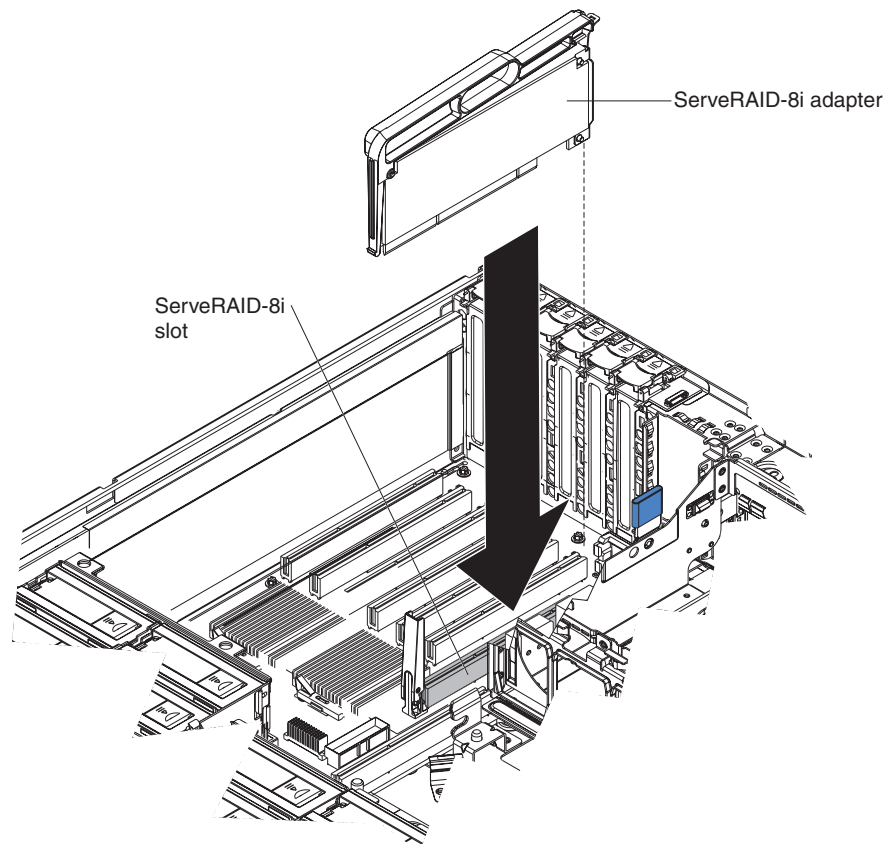

1. Read the safety information that begins on page v and “Installation guidelines” on page 21.
2. Turn off the server and peripheral devices, and disconnect the power cords. Remove the cover (see “Removing the cover and bezel” on page 23).
3. Remove all the cables from the connectors on the I/O board.
4. Touch the static-protective package that contains the adapter to any unpainted surface on the outside of the server; then, grasp the adapter by the top edge or upper corners of the adapter and remove it from the package.
5. Remove the ServeRAID-8i adapter from the package, using the plastic handle.

Attention: Incomplete insertion might cause damage to the server or the ServeRAID-8i adapter.

6. Position the ServeRAID-8i adapter so that the metal locking clasp is at the rear of the server; then, press the ServeRAID-8i adapter firmly into the connector.

If you have other options to install or remove, do so now; otherwise, go to “Completing the installation” on page 47.

Attention: Static electricity that is released to internal server components when the server is powered-on might cause the server to halt, which could result in the loss of data. To avoid this potential problem, always use an electrostatic-discharge wrist strap or other grounding system when working inside the server with the power on.

To install a hot-plug PCI or PCI-X adapter, complete the following steps.

Note: For hot-pluggable adapters, make sure that the PCI hot-plug device driver is installed.

1. Read the safety information that begins on page v and “Installation guidelines” on page 21.
2. If the adapter is not hot-pluggable, turn off the server and peripheral devices, and disconnect the power cords and all external cables.
3. Remove the server cover (see “Removing the cover and bezel” on page 23) and determine which PCI-X expansion slot you will use for the adapter.

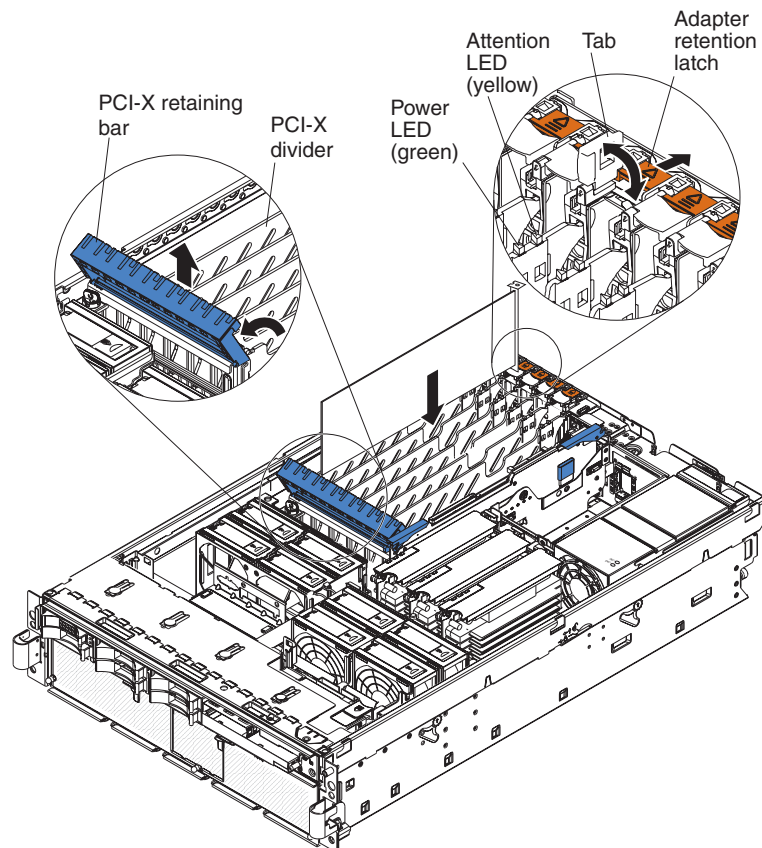

4. See the documentation that comes with the adapter for instructions for setting jumpers or switches and for cabling.

Note: Route adapter cables before you install the adapter.

5. Install the adapter:
 - a. Open the blue PCI-X retaining bar by lifting the front edge.
 - b. Push the orange adapter retention latch toward the rear of the server and open the tab. The power LED for the slot turns off.

- c. Remove the expansion-slot cover.
- d. Touch the static-protective package that contains the adapter to any unpainted surface on the outside of the server; then, grasp the adapter by the top edge or upper corners of the adapter and remove it from the package.
- e. Carefully grasp the adapter by its top edge or upper corners, and align it with the connector on the PCI-X board.
- f. If necessary, remove the adapter guide before installing a full-length adapter.

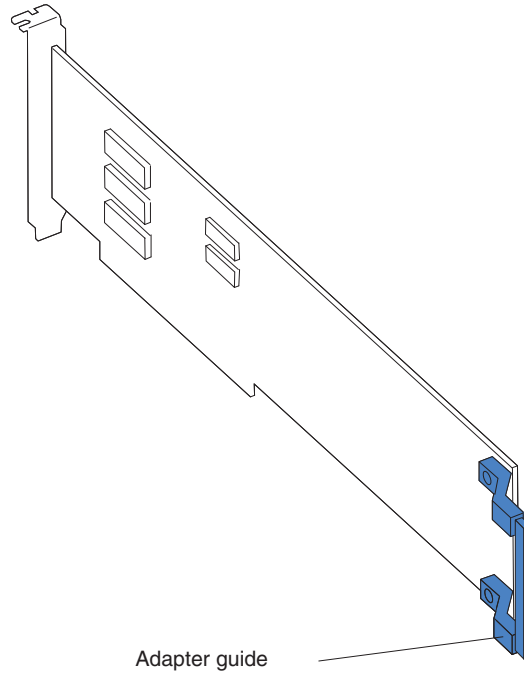

Attention: When you install an adapter, avoid touching the components and gold-edge connectors on the adapter. Make sure that the adapter is correctly seated in the connector. Incorrectly seated adapters might cause damage to the I/O board or to the adapter.

- g. Press the adapter *firmly* into the adapter connector.
 - h. Push down on the blue PCI-X retaining bar to stabilize the adapter.
 - i. Close the tab; then, push down on the orange adapter retention latch until it clicks into place, securing the adapter.
6. Connect any required cables to the adapter.

If you have other options to install or remove, do so now; otherwise, go to “Completing the installation” on page 47.

Installing a hot-swap hard disk drive

The following notes describe the types of hard disk drives that the server supports and other information that you must consider when installing a hard disk drive:

- The server supports up to six 1-inch (26 mm) slim-high, 2.5-inch, hot-swap hard disk drives in the standard hot-swap bays.
- For a list of supported options for the server, see <http://www.ibm.com/servers/eserver/serverproven/compat/us/>.
- Inspect the drive tray for signs of damage.
- Make sure that the drive is correctly installed in the tray.
- If a RAID controller is installed in the server, see the documentation that comes with the controller for instructions for installing a hard disk drive.
- All hot-swap drives in the server should have the same throughput speed rating; mixing speed ratings might cause all drives to operate at the lower throughput speed.
- To minimize the possibility of damage to the hard disk drives when you are installing the server in a rack configuration, install the server in the rack before installing the hard disk drives.
- You do not have to turn off the server to install hot-swap drives in the hot-swap drive bays. However, you must turn off the server when performing any steps that involve installing or removing cables.
- Some filler panels come with a slim filler.

The following illustration shows how to install a hot-swap hard disk drive.

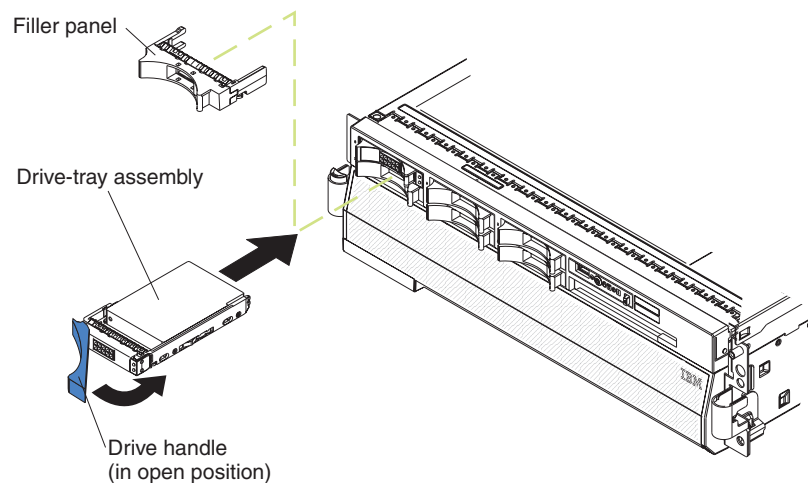

To install a hot-swap hard disk drive, complete the following steps:

1. Read the safety information that begins on page v and “Installation guidelines” on page 21.
2. Remove the filler panel from one of the empty hot-swap bays.
3. Touch the static-protective package that contains the hard disk drive to any unpainted surface on the outside of the server; then, remove the hard disk drive from the package.

4. Make sure that the tray handle is open; then, install the hard disk drive into the hot-swap bay.

Notes:

1. When you turn on the server, check the hard disk drive status LEDs to make sure that the hard disk drive is operating correctly.
If the amber hard disk drive status LED for a drive is lit continuously, that drive is faulty and must be replaced. If the green hard disk drive activity LED is flashing, the drive is being accessed.
2. If the server will be configured for RAID operation using a ServeRAID controller, you must configure the disk arrays before installing the operating system. See the ServeRAID documentation on the *IBM ServeRAID Support CD* for additional information about RAID operation and complete instructions for using ServeRAID Manager.

Memory module

The following notes describe the types of dual inline memory modules (DIMMs) that the server supports and other information that you must consider when installing DIMMs:

- The server supports 333 MHz, 1.8V, 240 pin, PC2-3200 single-ranked double data-rate (DDR) II, registered synchronous dynamic random-access memory (SDRAM) with error correcting code (ECC) DIMMs. These DIMMs must be compatible with the latest PC2-3200 SDRAM Registered DIMM specifications. For a list of the supported options for the server, see <http://www.ibm.com/servers/eserver/serverproven/compat/us/>.
- The server supports up to four memory cards. Each memory card holds up to four DIMMs.
- There must be at least one memory card with one pair of DIMMs installed for the server to operate.
- When you install additional DIMMs on a memory card, be sure to install them in pairs. All the DIMM pairs on each memory card must be the same size, and type.
- You do not have to save new configuration information to the BIOS when installing or removing DIMMs. The only exception is if you replace a DIMM that was marked as **Disabled** in the **Memory Settings** menu. In this case, you must re-enable the row in the Configuration/Setup Utility program or reload the default memory settings.
- When you restart the server after adding or removing a DIMM, the server displays a message that the memory configuration has changed.
- Install the DIMMs on each memory card in the order shown in the following tables, depending on which memory configuration you want to use. You must install at least one pair of DIMMs on each memory card.

Table 3. Primary memory card installation sequence

Memory card order	Memory card	DIMM pair
First	1	1 and 3
Second	2	1 and 3
Third	3	1 and 3
Fourth	4	1 and 3
Fifth	1	2 and 4
Sixth	2	2 and 4
Seventh	3	2 and 4
Eighth	4	2 and 4

Table 4. Alternate memory card installation sequence

Memory card order	Memory card	DIMM pair
First	1	1 and 3
		2 and 4
Second	3	1 and 3
		2 and 4
Third	2	1 and 3
		2 and 4

Table 4. Alternate memory card installation sequence (continued)

Memory card order	Memory card	DIMM pair
Fourth	4	1 and 3
		2 and 4

Table 5. Memory card installation sequence for memory-mirrored configuration

Memory card order	Memory card	DIMM pair
First	1	1 and 3
	3	1 and 3
Second	2	1 and 3
	4	1 and 3
Third	1	2 and 4
	3	2 and 4
Fourth	2	2 and 4
	4	2 and 4

- There are two memory power buses split between the four memory cards. Memory cards 1 and 2 are on power bus 1, and memory cards 3 and 4 are on power bus 2. If memory mirroring is enabled, you can hot-replace one memory card at a time on each memory power bus.
- If a problem with a DIMM is detected, light path diagnostics will light the system-error LED on the front of the server, indicating that there is a problem and guide you to the defective DIMM. When this occurs, first identify the defective DIMM; then, remove and replace the DIMM.

The following illustration shows the LEDs on the memory card:

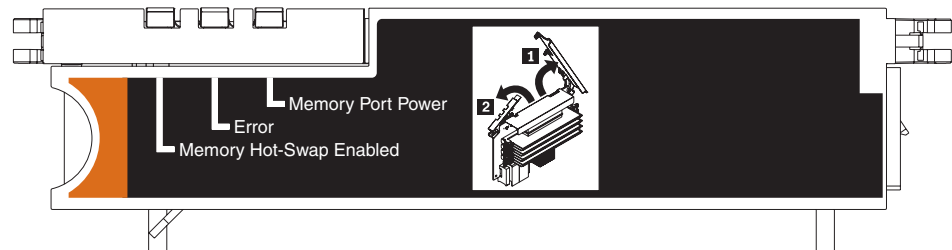

Memory Hot-Swap Enabled LED: When this LED is lit, it indicates that hot-swap memory is enabled.

Error LED: When this LED is lit, it indicates that a memory card or DIMM has failed.

Memory Port Power LED: When this LED is off, it indicates that power is removed from the port and that you can remove the memory card and replace a failed DIMM. This LED will also turn off when the release levers are opened.

Note: Add odd numbered DIMMs to each available memory card first, then add the even numbered pairs.

Active Memory

Active Memory is an IBM technology that improves the reliability of the DIMMs through the memory mirroring, memory scrubbing, and Memory ProteXion™ features.

The following notes describe the Active Memory features:

- Memory mirroring enables you to improve the reliability of the memory in your server by creating a mirror of the data in memory port 1 and storing it in memory port 2.

Note: For memory mirroring to work, you must have DIMMs of the same size and clock speed in both memory ports.

Complete the following steps to enable memory mirroring:

1. Check your operating system documentation to make sure that it supports memory mirroring.
2. Install DIMMs of the same size and clock speed in the two memory ports.
3. Enable memory mirroring in the Configuration/Setup Utility program:
 - a. Turn on the server and watch the monitor screen.
 - b. When the message Press F1 for Configuration/Setup appears, press F1.
 - c. From the Configuration/Setup Utility main menu, select **Advanced Setup**.
 - d. Select **Memory Settings**.
 - e. Select **Memory Mirroring Settings**.
 - f. **Enable** the memory mirroring setting from within this window.
 - g. Save and exit the Configuration/Setup Utility program.

When memory mirroring is enabled, the data that is written to memory is stored in two locations. One copy is kept in the memory port 1 DIMMs, while a second copy is kept in the memory port 2 DIMMs. During the execution of the read command, the data is read from the DIMM with the least number of reported memory errors through memory scrubbing, which is enabled with memory mirroring.

If memory scrubbing determines that a DIMM is damaged beyond use, read and write operations are redirected to the remaining good DIMMs. Memory scrubbing then reports the damaged DIMM and light path diagnostics displays the error. After the damaged DIMM is replaced, memory mirroring then copies the mirrored data back into the new DIMM.

- Memory scrubbing is an automatic daily test of all the system memory that detects and reports memory errors that might be developing before they cause a server outage.

Note: Memory scrubbing and Memory ProteXion technology work with each other and do not require memory mirroring to be enabled to work.

When an error is detected, memory scrubbing determines whether the error is recoverable. If it is recoverable, Memory ProteXion is enabled and the data that was stored in the damaged locations is rewritten to a new location. The error is then reported so that preventive maintenance can be performed. Provided that there are enough good locations to enable the correct operation of the server, no further action is taken other than recording the error in the error logs.

If the error is not recoverable, memory scrubbing sends an error message to light path diagnostics, which lights LEDs to guide you to the damaged DIMM. If memory mirroring is enabled, the mirrored copy of the data in the mirrored DIMM is used to refresh the new DIMM after it is installed.

- Memory ProteXion reassigns memory bits to new locations within memory when recoverable errors have been detected.

When a recoverable error is found by memory scrubbing, the Memory ProteXion feature writes the data that was to be stored in the damaged memory locations to spare memory locations within the same DIMM.

Adding and replacing a memory card

At least one memory card with one pair of DIMMs must be installed for the server to operate correctly.

Adding a memory card

Complete the following steps to add a memory card:

1. Read the safety information that begins on page v and “Installation guidelines” on page 21.
2. Turn off the server and peripheral devices, and disconnect the power cords and all external cables necessary to replace the device.
3. Remove the cover from the server (see “Removing the cover and bezel” on page 23).
4. Prepare the memory card:
 - a. Touch the static-protective package that contains the memory card to any unpainted surface on the outside of the server; then, remove the memory card from the package.
 - b. Place the memory card on a flat, static-protected surface with the DIMM connectors facing up.
 - c. Install DIMMs in the memory card (see “Installing DIMMs” on page 36).
5. Add the memory card:

Attention: When moving the memory card, do not allow it to touch any components or structures inside the server.

 - a. Grasp the memory card by the retention levers and turn the memory card so that the connector aligns with the connector on the microprocessor board.
 - b. Insert the memory card into the memory card connector.
 - c. Press the memory card into the connector and close the retention levers.

If you have other options to install or remove, do so now; otherwise, go to “Completing the installation” on page 47.

Hot-replacing a memory card

To hot-replace a memory card, memory mirroring must be enabled. See “Active Memory” on page 33 for information on how to enable memory mirroring.

Complete the following steps to hot-replace a memory card in the server:

1. Read the safety information that begins on page v and “Installation guidelines” on page 21.

Attention: Static electricity that is released to internal server components when the server is powered-on might cause the server to halt, which could result in the loss of data. To avoid this potential problem, always use an electrostatic-discharge wrist strap or other grounding system when working inside the server with the power on.
2. Remove the cover from the server (see “Removing the cover and bezel” on page 23).
3. Make sure the memory hot-swap enabled LED is lit on the top of the memory card to be replaced. If the LED is not lit, enable memory mirroring (see “Active Memory” on page 33).

4. Prepare the new memory card:
 - a. Touch the static-protective package that contains the memory card to any unpainted surface on the outside of the server; then, remove the memory card from the package.
 - b. Place the memory card on a flat, static-protected surface with the DIMM connectors facing up.
 - c. Install memory DIMMs in the memory card (see “Installing DIMMs”).
5. Remove the memory card from the server:

Attention: When moving the memory card, do not allow it to touch any components or structures inside the server.

 - a. Make sure that the retention levers on the edge of the memory card are fully open.
 - b. Lift the memory card out of the server.
6. Replace the memory card:
 - a. Grasp the new memory card by the retention levers and turn the memory card so that the connector aligns with the connector on the microprocessor board.
 - b. Insert the memory card into the memory card connector.
 - c. Press the memory card into the connector and close the small retention lever.
 - d. Wait two seconds and close the large retention lever.

If you have other options to install or remove, do so now; otherwise, go to “Completing the installation” on page 47.

Installing DIMMs

DIMMs must be installed in pairs of the same type and speed. To use the memory mirroring feature, all the DIMMs that are installed in the server must be of the same type and speed, and the operating system must support the feature. The following instructions are for installing one pair of DIMMs. To install DIMM pairs on more than one memory card, repeat steps 3 through 7 for each memory card.

Installing a DIMM

To install a DIMM, complete the following steps:

1. Read the safety information that begins on page v and “Installation guidelines” on page 21.
2. Turn off the server and peripheral devices, and disconnect the power cords and all external cables necessary to replace the device.

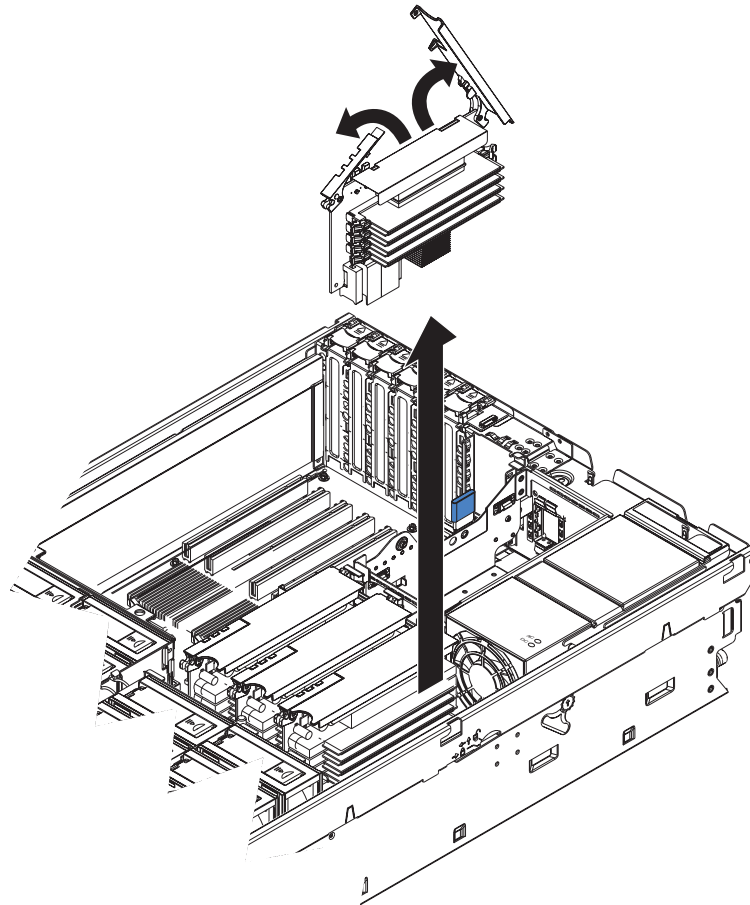

3. Remove the memory card.
 - a. Open the memory card retention levers on the top of the memory card.
 - b. While holding the retention levers open, lift the memory card out of the server.
4. Place a memory card on a flat, static-protected surface with the DIMM connectors facing up.

Attention: To avoid breaking the DIMM retaining clips or damaging the DIMM connectors, open and close the clips gently.
5. Open the retaining clip on each end of the DIMM connector.
6. Touch the static-protective package that contains the DIMM to any unpainted metal surface on the outside of the server; then, remove the DIMM from the package.
7. Turn the DIMM so that the DIMM keys align correctly with the slot.

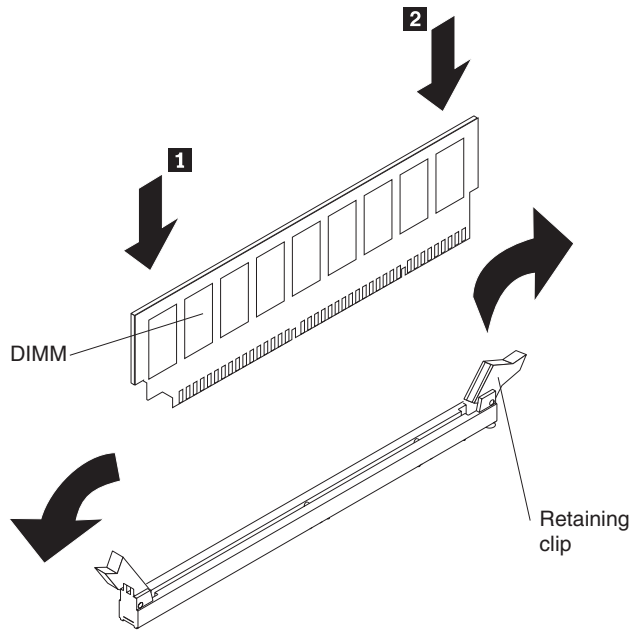

8. Insert the DIMM into the connector by aligning the edges of the DIMM with the slots at the ends of the DIMM connector.
9. Firmly press one end of the DIMM into the connector; then, press the other end into the connector. The retaining clips snap into the locked position when the DIMM is seated in the connector. If there is a gap between the DIMM and the retaining clips, the DIMM has not been correctly inserted; open the retaining clips, remove the DIMM, and then reinsert it.
10. Repeat steps 5 through 9 to install the second DIMM in the pair and for each additional pair that you install.
11. Replace the memory card:
 - a. Insert the memory card into the memory card connector.
 - b. Press the memory card into the connector and close the retention levers.

If you have other options to install or remove, do so now; otherwise, go to “Completing the installation” on page 47.

Hot-swapping DIMMs

To hot-swap DIMMs, complete the following steps:

1. Read the safety information that begins on page v and “Installation guidelines” on page 21.

Attention: Static electricity that is released to internal server components when the server is powered-on might cause the server to halt, which could result in the loss of data. To avoid this potential problem, always use an electrostatic-discharge wrist strap or other grounding system when working inside the server with the power on.
2. Remove the top cover from the server (see “Removing the cover and bezel” on page 23).

Attention: When moving the memory card, do not allow it to touch any components or structures inside the server.

Make sure that the memory hot-swap enabled LED is lit.

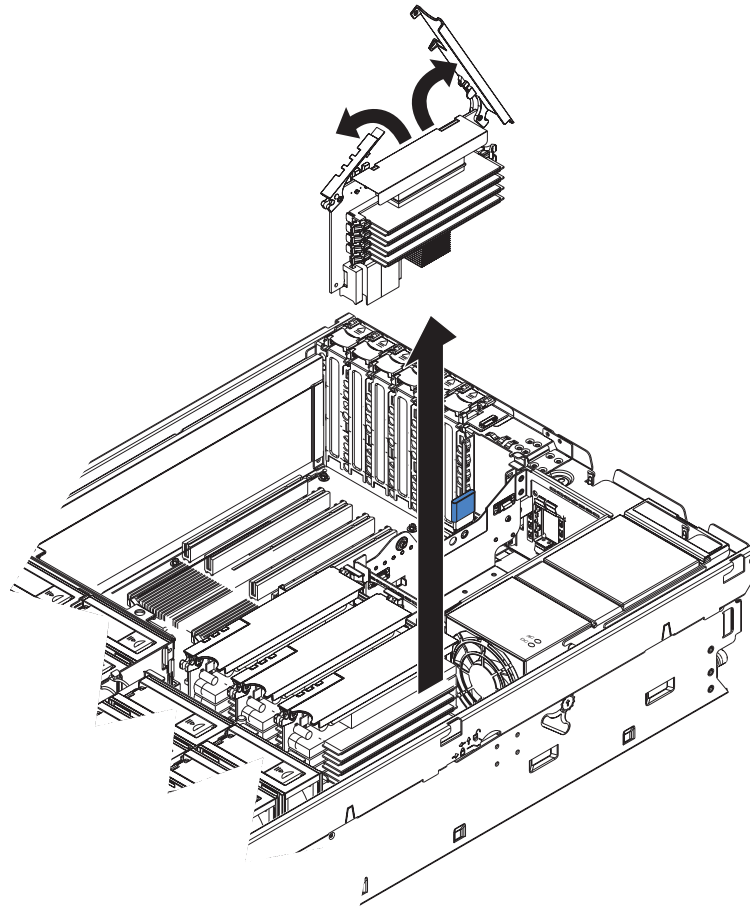

3. Remove the memory card.
 - a. Open the memory card retention levers on the top of the memory card.
 - b. While holding the retention levers open, lift the memory card out of the server.
4. Place a memory card on a flat, static-protected surface with the DIMM connectors facing up.

Attention: To avoid breaking the DIMM retaining clips or damaging the DIMM connectors, open and close the clips gently.
5. Open the retaining clip on each end of the DIMM connector and remove the DIMM or DIMMs to be replaced.
6. Touch the static-protective package that contains the DIMM to any unpainted metal surface on the outside of the server; then, remove the DIMM from the package.
7. Turn the DIMM so that the DIMM keys align correctly with the slot.

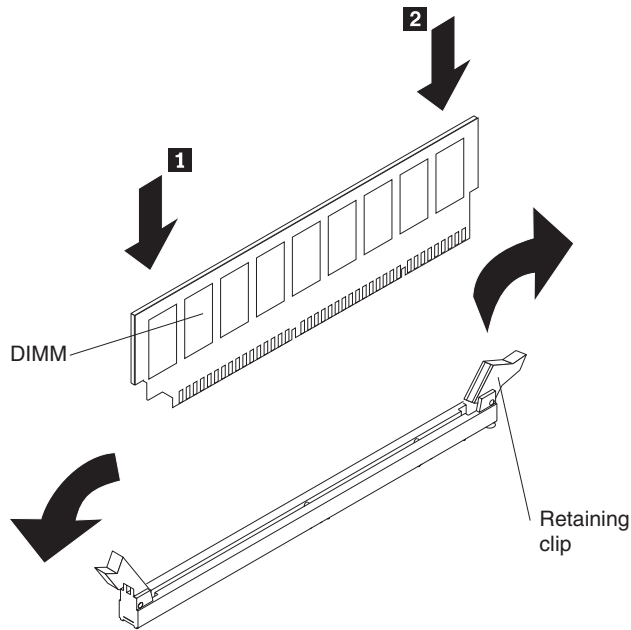

8. Insert the DIMM into the connector by aligning the edges of the DIMM with the slots at the ends of the DIMM connector.
9. Firmly press one end of the DIMM into the connector; then, press the other end into the connector. The retaining clips snap into the locked position when the DIMM is seated in the connector. If there is a gap between the DIMM and the retaining clips, the DIMM has not been correctly inserted; open the retaining clips, remove the DIMM, and then reinsert it.
10. Repeat steps 5 through 9 to replace any remaining DIMMs on the memory card.
11. Replace the memory card:
 - a. Insert the memory card into the memory card connector.
 - b. Press the memory card into the connector and close the small retention lever.
 - c. Wait two seconds and close the large retention lever.

If you have other options to install or remove, do so now; otherwise, go to “Completing the installation” on page 47.

Hot-adding DIMMs

To hot-add DIMMs and memory cards, complete the following steps:

1. Read the safety information that begins on page v and “Installation guidelines” on page 21.

Attention: Static electricity that is released to internal server components when the server is powered-on might cause the server to halt, which could result in the loss of data. To avoid this potential problem, always use an electrostatic-discharge wrist strap or other grounding system when working inside the server with the power on.
2. Remove the top cover from the server (see “Removing the cover and bezel” on page 23).

Attention: When moving the memory card, do not allow it to touch any components or structures inside the server.
3. Place a memory card on a flat, static-protected surface with the DIMM connectors facing up.

Attention: To avoid breaking the DIMM retaining clips or damaging the DIMM connectors, open and close the clips gently.

4. Open the retaining clip on each end of the DIMM connector.
5. Touch the static-protective package that contains the DIMM to any unpainted metal surface on the outside of the server; then, remove the DIMM from the package.
6. Turn the DIMM so that the DIMM keys align correctly with the slot.

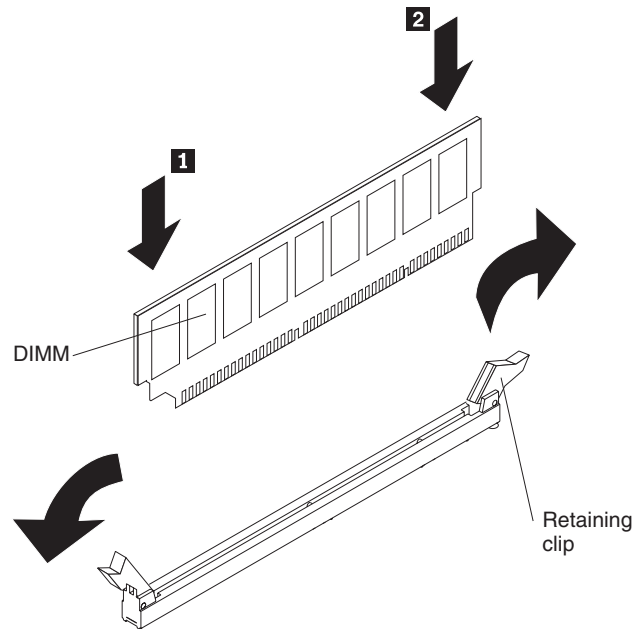

7. Insert the DIMM into the connector by aligning the edges of the DIMM with the slots at the ends of the DIMM connector.
8. Firmly press one end of the DIMM into the connector; then, press the other end into the connector. The retaining clips snap into the locked position when the DIMM is seated in the connector. If there is a gap between the DIMM and the retaining clips, the DIMM has not been correctly inserted; open the retaining clips, remove the DIMM, and then reinsert it.
9. Repeat steps 4 through 8 to install any remaining DIMMs on the memory card.

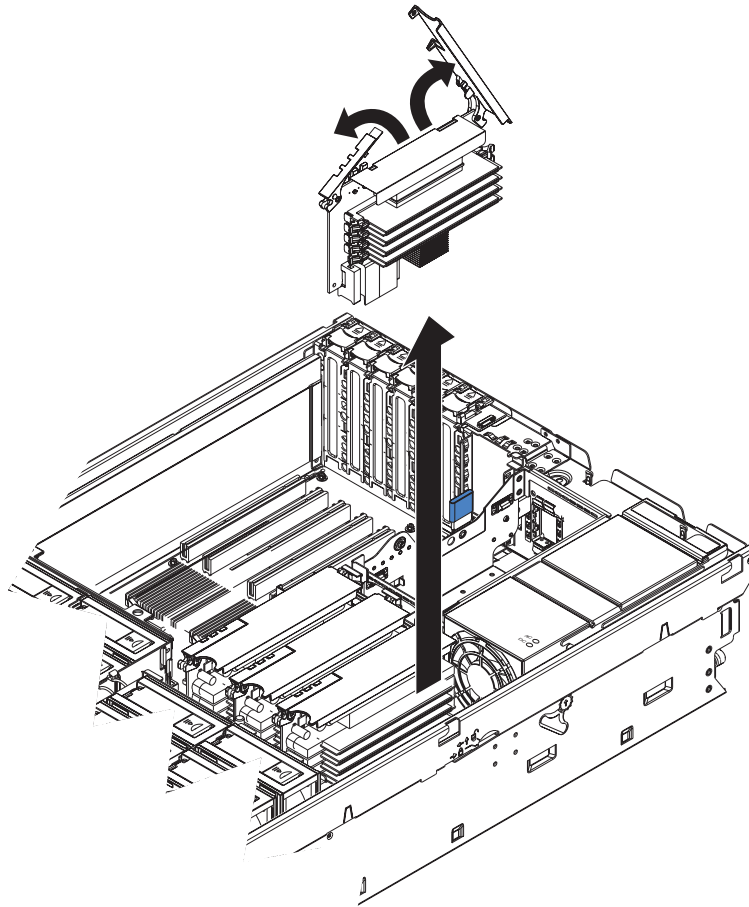

10. Open the memory card retention levers on the top of the memory card.
11. Insert the memory card into the memory card connector.
12. Press the memory card into the connector and close the small retention lever.
13. Wait two seconds and close the large retention lever.

If you have other options to install or remove, do so now; otherwise, go to “Completing the installation” on page 47.

Microprocessor

The following notes describe the type of microprocessor that the server supports and other information that you must consider when installing a microprocessor:

- For a list of supported options for the server, see <http://www.ibm.com/servers/eserver/serverproven/compat/us/>.
- The server supports up to four Intel Xeon microprocessors. If you are installing two or more microprocessors, they must be the same cache size and type, and the same clock speed.
- With more than one microprocessor, the server can operate as a symmetric multiprocessing (SMP) server. With SMP, certain operating systems and application programs can distribute the processing load among the microprocessors. This enhances performance for database and point-of-sale applications, integrated manufacturing solutions, and other applications.
- The voltage regulators for microprocessors 1 and 2 are integrated on the microprocessor board; the VRMs for microprocessors 3 and 4 come with the microprocessor options and must be installed on the microprocessor board.

- Read the documentation that comes with the microprocessor to determine whether you must update the basic input/output system (BIOS) code in the server. To download the most current level of BIOS code for your server, see <http://www.ibm.com/servers/eserver/support/xseries/index.html>.
- Obtain an SMP-capable operating system. For a list of supported operating systems, see <http://www.ibm.com/servers/eserver/serverproven/compat/us/>.
- You can use the Configurations/Setup utility program to determine the specific type of microprocessor in the server.

Microprocessor installation order

The following notes describe the order in which to populate the microprocessor connectors:

- For most configurations, populate the microprocessor connectors in numeric order, starting with connector 1.
- If you plan to create a two-node configuration using four dual-core microprocessors, you can populate the microprocessor connectors to improve performance. The following notes describe information that you must consider when configuring the servers to use the configuration:
 - You must create this configuration using one System x3950 (xSeries 460) server as the primary node and one System x3950 E (xSeries 460 MXE) server as the secondary node.
 - Only the configuration described in these instructions is supported to improve performance.
 - See this section for instructions on installing a microprocessor.
 - See the *Problem Determination and Service Guide* for instructions on removing a microprocessor.
 - Use this configuration only with supported Windows 2003 operating systems.

To configure a two-node configuration to use the four dual-core microprocessor configuration, complete the following steps.

Important: The grease on the heat sink and microprocessor will remain effective when you move a microprocessor from one connector to another connector, if you observe the following precautions:

- Carefully handle the heat sink and microprocessor when removing or installing these components. Do not touch the grease or otherwise allow it to become contaminated.
 - Because the microprocessor and heat sink are a matched set, transfer the microprocessor and heat sink from one connector to another connector one microprocessor and heat sink at a time. (This will ensure that the grease remains evenly distributed between each heat sink and microprocessor.)
1. Remove the microprocessor and heat sink installed in connector 2 of the primary node and install it in connector 1 of the secondary node.
 2. Install a microprocessor and heat sink option in connector 3 of the primary node and install a VRM in VRM connector 3.
 3. Install a microprocessor and heat sink option in connector 3 of the secondary node and install a VRM in VRM connector 3.

Note: To install additional microprocessors in this configuration, populate connector 2; then, connector 4 in the primary node. To install additional microprocessors, populate connector 2; then, connector 4 in the secondary node.

The following illustration shows the location of the microprocessor connectors and VRM connectors:

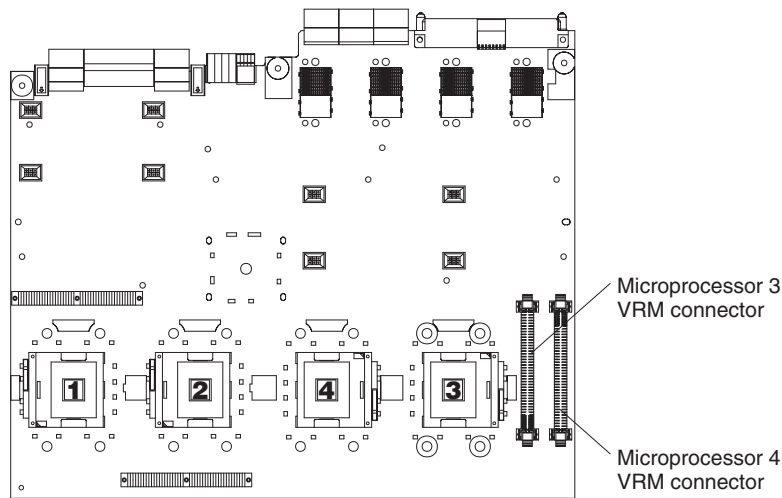

Installing a microprocessor

To install a microprocessor, complete the following steps:

1. Read the safety information that begins on page v and “Installation guidelines” on page 21.
2. Turn off the server and peripheral devices, and disconnect the power cords. Remove the cover and bezel (see “Removing the cover and bezel” on page 23).

Attention: When you handle static-sensitive devices, take precautions to avoid damage from static electricity. For details about handling these devices, see “Handling static-sensitive devices” on page 23.

3. Remove the microprocessor tray:
 - a. Remove the fans from the server.
 - b. Remove the memory cards from the server.
 - c. Lift the microprocessor-tray release latch.

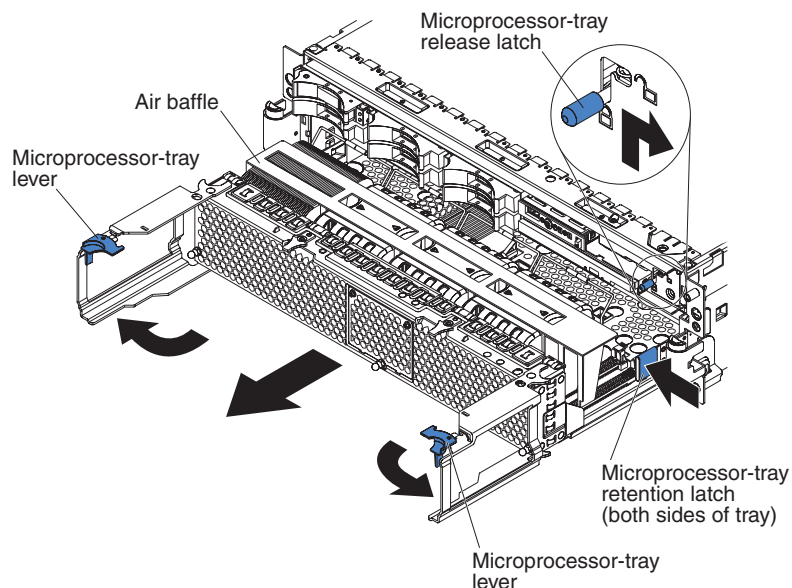

- d. Open the microprocessor-tray levers.

- e. Pull out the microprocessor tray until it stops; then, push in on the microprocessor tray retention latches on each side of the tray and pull the tray out of the server.

Attention: The microprocessor tray is heavy. Pull the tray partially out of the server, reposition your hands to grasp the body of the tray, and press in on the release latches on each side of the tray; then, pull the tray out the rest of the way.

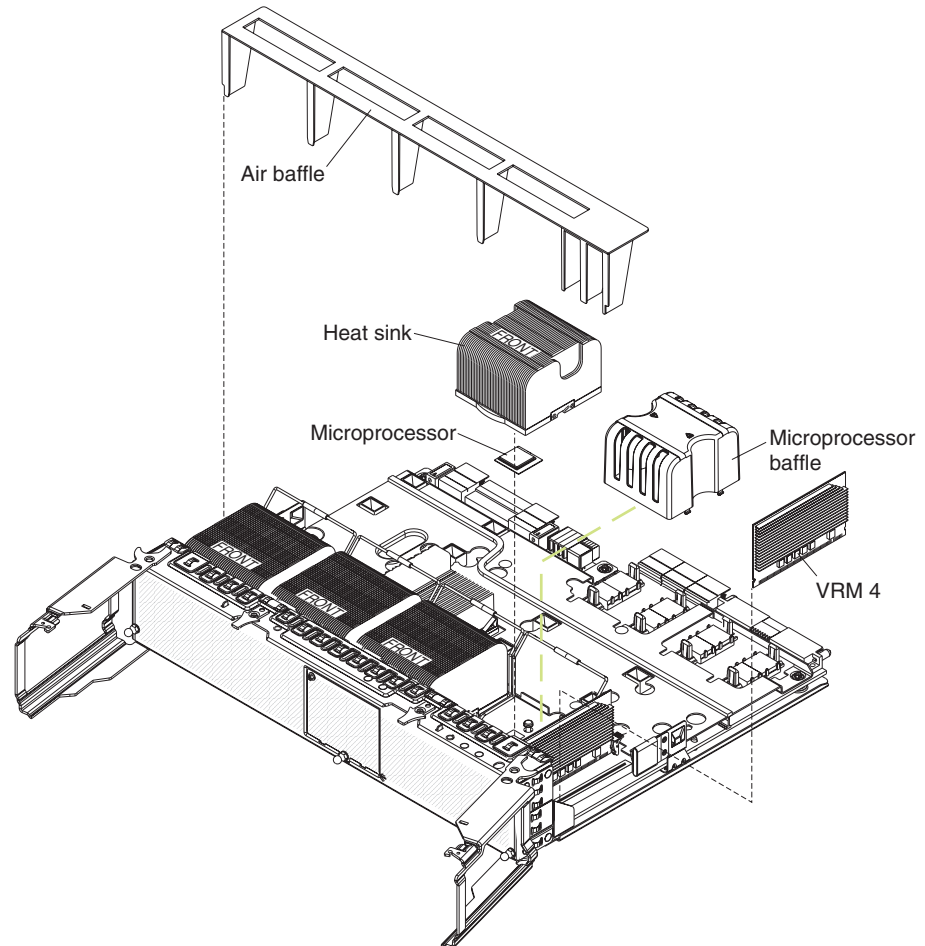

Note: The new microprocessor comes in a kit with a VRM and a heat sink. The VRM is used only with a microprocessor that is installed in socket 3 or 4.

4. Lift the air baffle out of the microprocessor tray.
5. Remove the microprocessor baffle from a microprocessor socket and store it for future use.
6. Remove the protective cover, tape, or label from the surface of the microprocessor socket, if any is present.
7. Lift the microprocessor-release lever to the fully open position (approximately 135° angle).

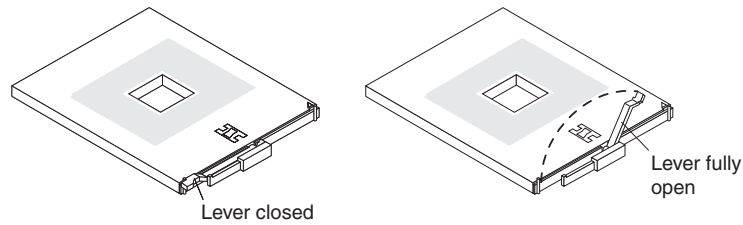

Note: Two of the microprocessor sockets are mounted on the microprocessor board with the microprocessor-release lever on the opposite side. These sockets are rotated 180° on the microprocessor board. Be sure to verify the orientation of the socket before installing the microprocessor.

8. Touch the static-protective package that contains the new microprocessor to any unpainted metal surface on the outside of the server; then, remove the microprocessor from the package.

Attention: To avoid bending the pins on the microprocessor, do not use excessive force when pressing it into the socket

9. Position the microprocessor over the microprocessor socket and carefully press the microprocessor into the socket.

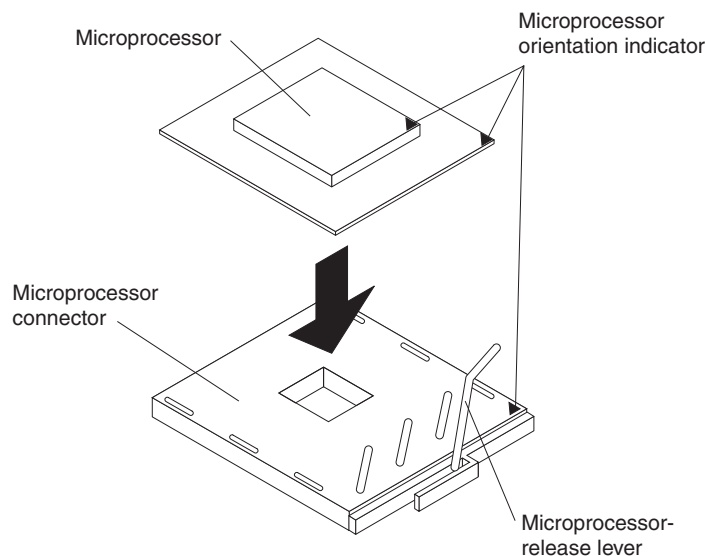

10. Close the microprocessor-release lever to secure the microprocessor.
11. Open the heat-sink retaining clip:
 - a. Press down on the center of the heat-sink retaining clip. This will cause the clip to flex and release it from the tabs on the heat-sink socket.
 - b. Lift the heat-sink retaining clip to the fully open position (approximately 135° angle).
12. Remove the heat sink from its package and remove the cover from the bottom of the heat sink.
13. Remove the release liner and orient the heat sink above the microprocessor; then, press the heat sink into place and close the heat-sink release lever.
14. If you have other microprocessors to install, do so now by repeating steps 5 through 13.
15. Install the air baffle in the microprocessor tray.
16. Reinstall the microprocessor tray in the server:

- a. Make sure that the microprocessor-tray release latch is open; then, push the microprocessor tray into the server.
- b. Close the tray levers and make sure that they are securely latched.
- c. Press the microprocessor-tray release latch down.
- d. Reinstall the fans and memory cards in the server.

If you have other options to install or remove, do so now; otherwise, go to “Completing the installation.”

Completing the installation

To complete the installation, complete the following steps:

1. If you removed the server cover, place the cover-release latch in the open (up) position. Insert the bottom tabs of the top cover into the matching slots in the server chassis. Press down on the cover-release latch to lock the cover in place. Replace the bezel, if you removed it.

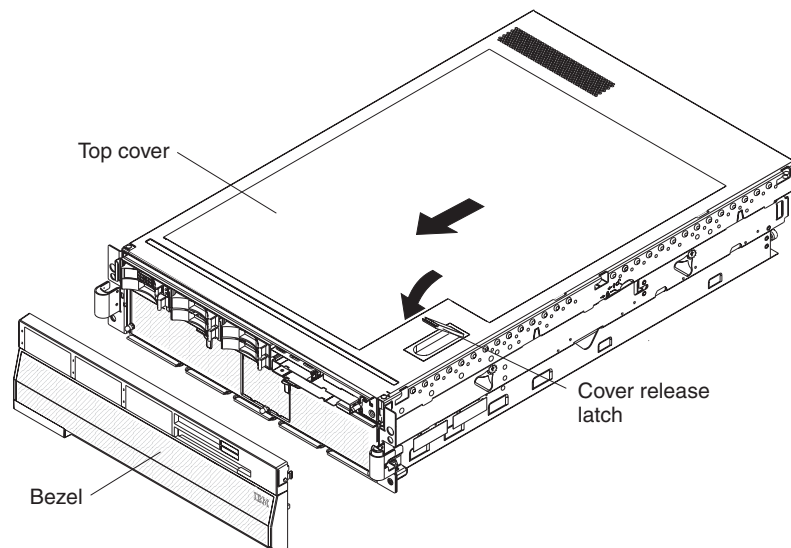

2. Install the server in a rack. See the *Rack Installation Instructions* that come with the server for complete rack installation and removal instructions.

Attention:

- Install the server only in a rack cabinet with perforated doors.
 - Do not leave open spaces above or below an installed server in the rack cabinet. To help prevent damage to server components, always install a blank filler panel to cover the open space and to help ensure proper air circulation. See the documentation that comes with your rack cabinet for more information.
3. Connect the cables and power cords. See “Connecting the cables” on page 48 for more information.

Connecting the cables

You must turn off the server (see “Server power features” on page 12) before connecting any cables to or disconnecting any cables from the server.

See the documentation that comes with optional devices for additional cabling instructions. It might be easier for you to route cables before you install certain options.

Cable identifiers are printed on the cables that come with the server and options. Use these identifiers to connect the cables to the correct connectors.

For details about the location and function of the input and output connectors, see “Server controls, connectors, LEDs, and power” on page 9.

Two optional SMP Expansion cable kits are available to interconnect the SMP Expansion Ports of two or more servers:

- 2.3 m XpandOnDemand™ Scalability cable kit (comes with one 2.3-m (7.6-foot) SMP Expansion cable)
- 2.9 m XpandOnDemand Scalability cable kit (comes with one 2.9-m (9.5-foot) SMP Expansion cable)

The following illustrations show the locations of the input and output connectors on the server. Detailed cabling instructions are in the *Rack Installation Instructions* that come with the server.

Rear view

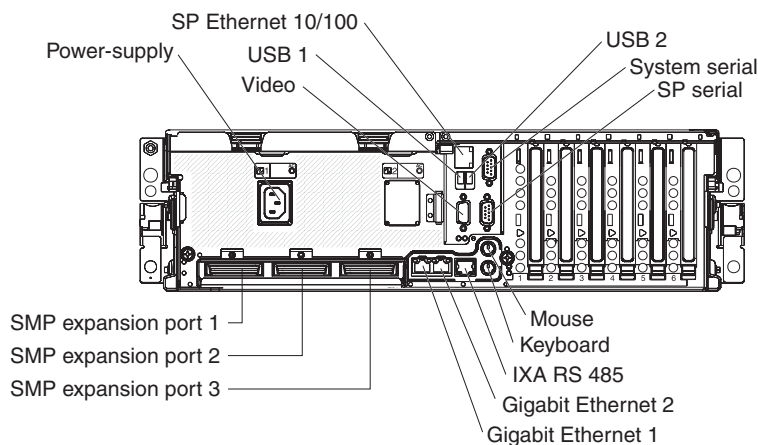

Front view

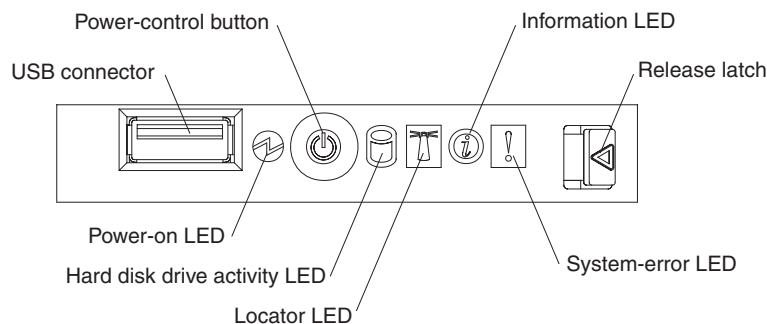

Updating the server configuration

When you start the server for the first time after you add or remove an internal option or external SAS or SCSI device, you might receive a message that the configuration has changed. The Configuration/Setup Utility program starts automatically so that you can save the new configuration settings. For more information, see “Using the Configuration/Setup Utility program” on page 58.

Some options have device drivers that you must install. For information about installing device drivers, see the documentation that comes with each option.

If more than one microprocessor is installed, the server can operate as a symmetric multiprocessing (SMP) server. You might have to upgrade the operating system to support SMP. For more information, see “Using the ServerGuide Setup and Installation CD” on page 63 and the operating-system documentation.

If the server has an optional RAID adapter and you have installed or removed a hard disk drive, see the documentation that comes with the RAID adapter for information about reconfiguring the disk arrays.

For information about configuring the integrated Gigabit Ethernet controller, see “Configuring the Gigabit Ethernet controller” on page 66.

SMP Expansion cabling

The cabling information in this section is for multi-node configurations that consist of two, four, or eight servers, for up to 32-way operation. A node is a server that is interconnected with other servers or nodes through the SMP Expansion Ports to share system resources.

To configure and cable a multi-node configuration, complete the following steps:

1. Update the BIOS code and the service processor firmware. To download the most current level of BIOS code and service processor firmware, go to <http://www.ibm.com/servers/eserver/support/xseries/index.html>.
2. Make sure that each System x3950 E node contains a minimum of one microprocessor and one memory card with one pair of DIMMs.
3. Make sure that each microprocessor in the multi-node configuration is the same cache size and type, and the same clock speed.
4. Make sure that the service processor on each node is configured and connected to the network. See the *Remote Supervisor Adapter II SlimLine and Remote Supervisor Adapter II User's Guide* for more information.
5. Cable the configuration, using the instructions in this section.
6. Configure the scalable partition. See “Using the Scalable Partition Web Interface” on page 81.
7. Press the power-control button on the primary node to turn on the multi-node configuration manually.

Two-node configuration

A two-node configuration requires two 2.3-m (7.6-foot) XpandOnDemand Scalability cable kits. To cable a two-node configuration for up to 8-way operation, complete the following steps:

1. Remove the protective covers from the connectors on the ends of the cables.

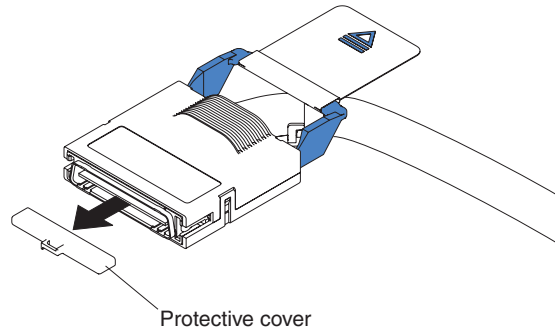

2. Label each end of the SMP Expansion cables according to where it will be connected to each server. See the following illustration.

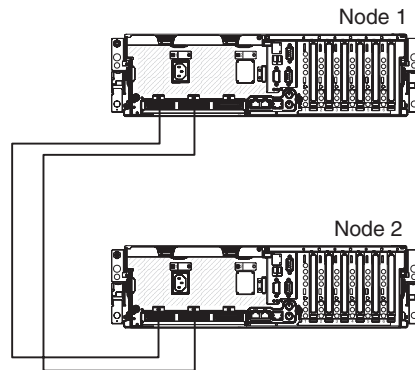

3. Connect the SMP Expansion cables to node 1:
 - a. Connect one end of an SMP Expansion cable to port 1 on node 1; then, route the cable through the node 1 cable-management arm. Use a 2.3-m (7.6-foot) SMP Expansion cable for this connection.
 - b. Connect one end of an SMP Expansion cable to port 2 on node 1; then, route the cable through the node 1 cable-management arm. Use a 2.3-m (7.6-foot) SMP Expansion cable for this connection.
4. Connect the SMP Expansion cables to node 2:
 - a. Locate the SMP Expansion cable that is connected to port 1 on node 1; then, connect the opposite end of the cable to port 1 of node 2. Next, route the cable through the node 2 cable-management arm.
 - b. Locate the SMP Expansion cable that is connected to port 2 on node 1; then, connect the opposite end of the cable to port 2 of node 2. Next, route the cable through the node 2 cable-management arm.
5. Route any remaining cables through the cable-management arms.
6. Secure the cables in the cable-management arms with the hook-and-loop straps that come with the server.

Four-node configuration

A four-node configuration requires six 2.3-m (7.6-foot) XpandOnDemand Scalability cable kits. To cable a four-node configuration for up to 16-way operation, complete the following steps:

1. Remove the protective covers from the connectors on the ends of the cables.

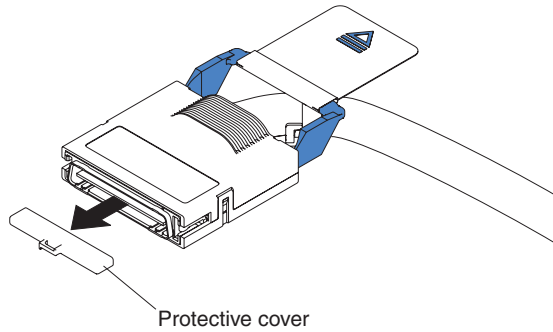

2. Label each end of the SMP Expansion cables according to where it will be connected to each server. See the following illustration.

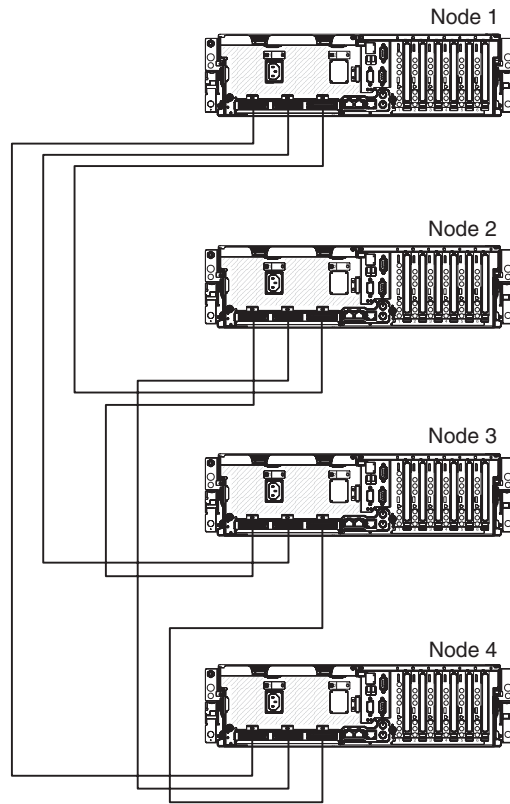

3. Connect the SMP Expansion cables to node 1:
 - a. Connect one end of an SMP Expansion cable to port 1 on node 1; then, route the cable through the node 1 cable-management arm. Use a 2.3-m (7.6-foot) SMP Expansion cable for this connection.
 - b. Connect one end of an SMP Expansion cable to port 2 on node 1; then, route the cable through the node 1 cable-management arm. Use a 2.3-m (7.6-foot) SMP Expansion cable for this connection.
 - c. Connect one end of an SMP Expansion cable to port 3 on node 1; then, route the cable through the node 1 cable-management arm. Use a 2.3-m (7.6-foot) SMP Expansion cable for this connection.
4. Connect the SMP Expansion cables to node 2:
 - a. Connect one end of an SMP Expansion cable to port 1 on node 2; then, route the cable through the node 2 cable-management arm. Use a 2.3-m (7.6-foot) SMP Expansion cable for this connection.

- b. Connect one end of an SMP Expansion cable to port 2 on node 2; then, route the cable through the node 2 cable-management arm. Use a 2.3-m (7.6-foot) SMP Expansion cable for this connection.
 - c. Locate the SMP Expansion cable that is connected to port 3 on node 1; then, connect the opposite end of the cable to port 3 of node 2. Next, route the cable through the node 2 cable-management arm.
5. Connect the SMP Expansion cables to node 3:
 - a. Locate the SMP Expansion cable that is connected to port 1 on node 2; then, connect the opposite end of the cable to port 1 of node 3. Next, route the cable through the node 3 cable-management arm.
 - b. Locate the SMP Expansion cable that is connected to port 2 on node 1; then, connect the opposite end of the cable to port 2 of node 3. Next, route the cable through the node 3 cable-management arm.
 - c. Connect one end of an SMP Expansion cable to port 3 on node 3; then, route the cable through the node 3 cable-management arm. Use a 2.3-m (7.6-foot) SMP Expansion cable for this connection.
6. Connect the SMP Expansion cables to node 4:
 - a. Locate the SMP Expansion cable that is connected to port 1 on node 1; then, connect the opposite end of the cable to port 1 of node 4. Next, route the cable through the node 4 cable-management arm.
 - b. Locate the SMP Expansion cable that is connected to port 2 on node 2; then, connect the opposite end of the cable to port 2 of node 4. Next, route the cable through the node 4 cable-management arm.
 - c. Locate the SMP Expansion cable that is connected to port 3 on node 3; then, connect the opposite end of the cable to port 3 of node 4. Next, route the cable through the node 4 cable-management arm.
7. Route any remaining cables through the cable-management arms.
8. Secure the cables in the cable-management arms with the hook-and-loop straps that come with the server.

Eight-node configuration

An eight-node configuration requires four 2.9-m (9.5-foot) XpandOnDemand Scalability cable kits and eight 2.3-m (7.6-foot) XpandOnDemand Scalability cable kits. To cable an eight-node configuration for up to 32-way operation, complete the following steps:

1. Remove the protective covers from the connectors on the ends of the cables.

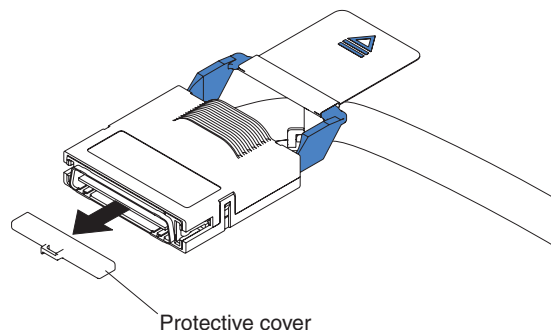

2. Label each end of the SMP Expansion cables according to where it will be connected to each server. See the following illustration.

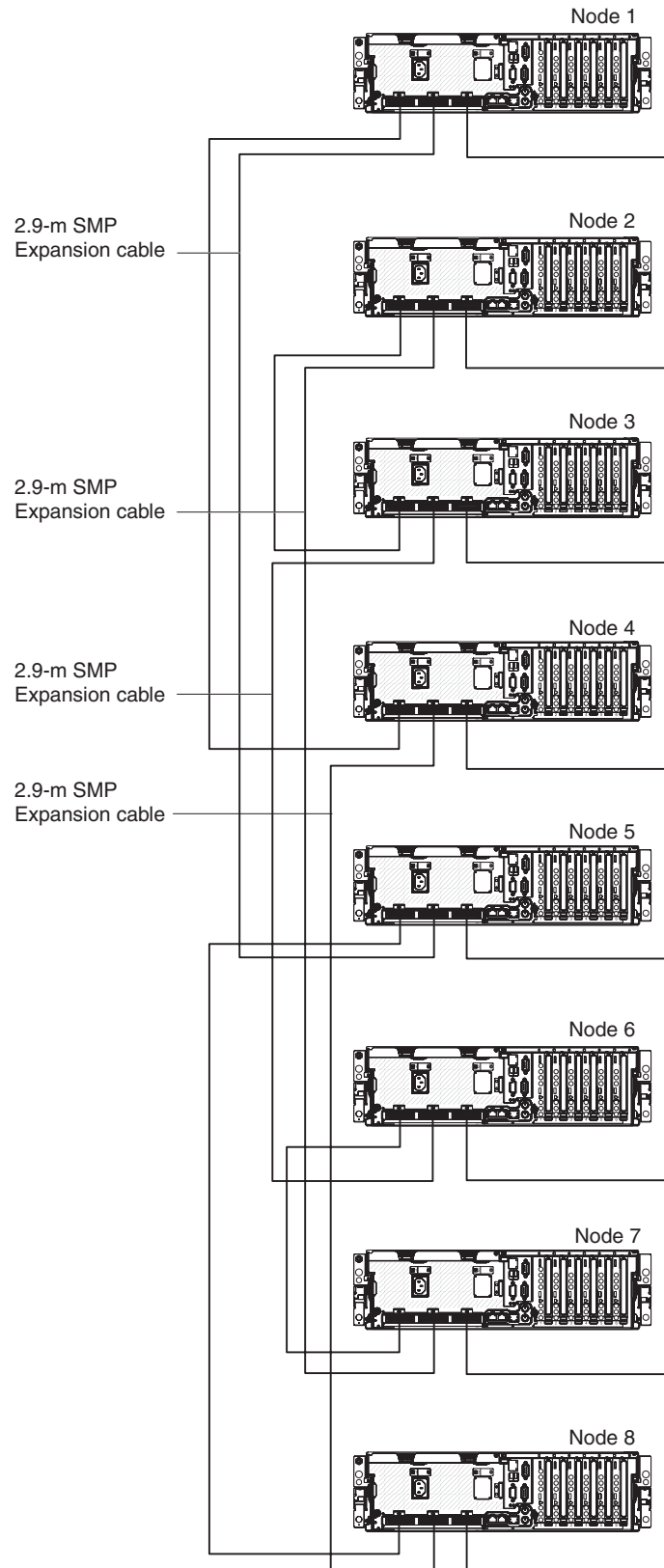

3. Connect the SMP Expansion cables to node 1:
 - a. Connect one end of an SMP Expansion cable to port 1 on node 1; then, route the cable through the node 1 cable-management arm. Use a 2.3-m (7.6-foot) SMP Expansion cable for this connection.

- b. Connect one end of an SMP Expansion cable to port 2 on node 1; then, route the cable through the node 1 cable-management arm. Use a 2.9-m (9.5-foot) SMP Expansion cable for this connection.
 - c. Connect one end of an SMP Expansion cable to port 3 on node 1; then, route the cable through the node 1 cable-management arm. Use a 2.3-m (7.6-foot) SMP Expansion cable for this connection.
4. Connect the SMP Expansion cables to node 2:
 - a. Connect one end of an SMP Expansion cable to port 1 on node 2; then, route the cable through the node 2 cable-management arm. Use a 2.3-m (7.6-foot) SMP Expansion cable for this connection.
 - b. Connect one end of an SMP Expansion cable to port 2 on node 2; then, route the cable through the node 2 cable-management arm. Use a 2.9-m (9.5-foot) SMP Expansion cable for this connection.
 - c. Locate the SMP Expansion cable that is connected to port 3 on node 1; then, connect the opposite end of the cable to port 3 of node 2. Next, route the cable through the node 2 cable-management arm.
5. Connect the SMP Expansion cables to node 3:
 - a. Locate the SMP Expansion cable that is connected to port 1 on node 2; then, connect the opposite end of the cable to port 1 of node 3. Next, route the cable through the node 3 cable-management arm.
 - b. Connect one end of an SMP Expansion cable to port 2 on node 3; then, route the cable through the node 3 cable-management arm. Use a 2.9-m (9.5-foot) SMP Expansion cable for this connection.
 - c. Connect one end of an SMP Expansion cable to port 3 on node 3; then, route the cable through the node 3 cable-management arm. Use a 2.3-m (7.6-foot) SMP Expansion cable for this connection.
6. Connect the SMP Expansion cables to node 4:
 - a. Locate the SMP Expansion cable that is connected to port 1 on node 1; then, connect the opposite end of the cable to port 1 of node 4. Next, route the cable through the node 4 cable-management arm.
 - b. Connect one end of an SMP Expansion cable to port 2 on node 4; then, route the cable through the node 4 cable-management arm. Use a 2.9-m (9.5-foot) SMP Expansion cable for this connection.
 - c. Locate the SMP Expansion cable that is connected to port 3 on node 3; then, connect the opposite end of the cable to port 3 of node 4. Next, route the cable through the node 4 cable-management arm.
7. Connect the SMP Expansion cables to node 5:
 - a. Connect one end of an SMP Expansion cable to port 1 on node 5; then, route the cable through the node 5 cable-management arm. Use a 2.3-m (7.6-foot) SMP Expansion cable for this connection.
 - b. Locate the SMP Expansion cable that is connected to port 2 on node 1; then, connect the opposite end of the cable to port 2 of node 5. Next, route the cable through the node 5 cable-management arm.
 - c. Connect one end of an SMP Expansion cable to port 3 on node 5; then, route the cable through the node 5 cable-management arm. Use a 2.3-m (7.6-foot) SMP Expansion cable for this connection.
8. Connect the SMP Expansion cables to node 6:
 - a. Connect one end of an SMP Expansion cable to port 1 on node 6; then, route the cable through the node 6 cable-management arm. Use a 2.3-m (7.6-foot) SMP Expansion cable for this connection.

- b. Locate the SMP Expansion cable that is connected to port 2 on node 3; then, connect the opposite end of the cable to port 2 of node 6. Next, route the cable through the node 6 cable-management arm.
 - c. Locate the SMP Expansion cable that is connected to port 3 on node 5; then, connect the opposite end of the cable to port 3 of node 6. Next, route the cable through the node 6 cable-management arm.
 9. Connect the SMP Expansion cables to node 7:
 - a. Locate the SMP Expansion cable that is connected to port 1 on node 6; then, connect the opposite end of the cable to port 1 of node 7. Next, route the cable through the node 7 cable-management arm.
 - b. Locate the SMP Expansion cable that is connected to port 2 on node 2; then, connect the opposite end of the cable to port 2 of node 7. Next, route the cable through the node 7 cable-management arm.
 - c. Connect one end of an SMP Expansion cable to port 3 on node 7; then, route the cable through the node 7 cable-management arm. Use a 2.3-m (7.6-foot) SMP Expansion cable for this connection.
 10. Connect the SMP Expansion cables to node 8:
 - a. Locate the SMP Expansion cable that is connected to port 1 on node 5; then, connect the opposite end of the cable to port 1 of node 8. Next, route the cable through the node 8 cable-management arm.
 - b. Locate the SMP Expansion cable that is connected to port 2 on node 4; then, connect the opposite end of the cable to port 2 of node 8. Next, route the cable through the node 8 cable-management arm.
 - c. Locate the SMP Expansion cable that is connected to port 3 on node 7; then, connect the opposite end of the cable to port 3 of node 8. Next, route the cable through the node 8 cable-management arm.
 11. Route any remaining cables through the cable-management arms.
 12. Secure the cables in the cable-management arms with the hook-and-loop straps that come with the server.

Chapter 3. Configuring the server

The following configuration programs and capabilities come with the server:

- **Configuration/Setup Utility program**

The Configuration/Setup Utility program is part of the basic input/output system (BIOS) code in the server. Use it to configure serial port assignments and scalable partitions, change interrupt request (IRQ) settings, change the startup-device sequence, set the date and time, and set passwords. For information about using this utility program, see “Using the Configuration/Setup Utility program” on page 58.

- **IBM ServerGuide Setup and Installation CD**

The ServerGuide program provides software-setup tools and installation tools that are designed for the server. Use this CD during the installation of the server to configure basic hardware features, such as an integrated SCSI controller with RAID capabilities, and to simplify the installation of your operating system. For information about using this CD, see “Using the ServerGuide Setup and Installation CD” on page 63.

- **Preboot Execution Environment (PXE) boot agent utility program**

The PXE boot agent utility program is part of the BIOS code in the server. Use it to change network startup (boot) protocols and startup order and to select operating-system wake-up support. For information about using this utility program, see “Using the PXE boot agent utility program” on page 66.

- **Boot Menu program**

The Boot Menu program is part of the BIOS code. Use it to override the startup sequence that is set in the Configuration/Setup Utility program and temporarily assign a device to be first in the startup sequence.

- **Gigabit Ethernet controller configuration process**

For information about configuring the Ethernet controller, see “Configuring the Gigabit Ethernet controller” on page 66.

- **Baseboard management controller utility programs**

Use these programs to configure the baseboard management controller. The utilities also provide the capability to update the firmware and sensor data record/field replaceable unit (SDR/FRU) data and to configure a network for remote server management. For information about using the baseboard management controller utility programs, see “Installing and using the baseboard management controller utility programs” on page 67.

- **SAS/SATA Configuration Utility program**

Use the SAS/SATA Configuration Utility program to configure devices that are attached to the SAS controller. For information about using this utility program, see “Using the SAS/SATA Configuration Utility program” on page 79.

- **Remote Supervisor Adapter II SlimLine configuration**

For information about setting up and cabling the Remote Supervisor Adapter II SlimLine, see the *Remote Supervisor Adapter II SlimLine and Remote Supervisor Adapter II User's Guide* on the IBM System x Documentation CD.

- **Scalable-partition configuration**

For information about creating and removing scalable partitions, see “Using the Scalable Partition Web Interface” on page 81.

- **ServeRAID Manager**

ServeRAID Manager is available as a stand-alone program and as an IBM Director extension. If a ServeRAID adapter is installed in the server, use

ServeRAID Manager to define and configure your disk-array subsystem *before* you install the operating system. For information about using this program, see “Using ServeRAID Manager” on page 79.

Using the Configuration/Setup Utility program

Use the Configuration/Setup Utility program to:

- View configuration information
- View and change assignments for devices and I/O ports
- Set the date and time
- Set and change passwords
- Set the startup characteristics of the server and the order of startup devices
- Set and change settings for advanced hardware features
- View and clear error logs
- Change interrupt request (IRQ) settings
- Enable USB legacy keyboard and mouse support
- Resolve configuration conflicts

Starting the Configuration/Setup Utility program

To start the Configuration/Setup Utility program, complete the following steps:

1. Turn on the server.
2. When the prompt Press F1 for Configuration/Setup appears, press F1. If you have set both a power-on password and an administrator password, you must type the administrator password to access the full Configuration/Setup Utility menu. If you do not type the administrator password, a limited Configuration/Setup Utility menu is available.
3. Select settings to view or change.

Configuration/Setup Utility menu choices

The following choices are on the Configuration/Setup Utility main menu. Depending on the version of the BIOS code in the server, some menu choices might differ slightly from these descriptions.

- **System Summary**

Select this choice to view configuration information, including the type, speed, and cache sizes of the microprocessors, type and speed of installed USB devices, and the amount of installed memory. When you make configuration changes through other options in the Configuration/Setup Utility program, the changes are reflected in the system summary; you cannot change settings directly in the system summary.

This choice is on the full and limited Configuration/Setup Utility menu.

- **System Information**

Select this choice to view information about the server. When you make changes through other options in the Configuration/Setup Utility program, some of those changes are reflected in the system information; you cannot change settings directly in the system information.

This choice is on the full Configuration/Setup Utility menu only.

- **Product Data**

Select this choice to view the machine type and model of the server, the serial number, the revision level or issue date of the BIOS and diagnostics code

stored in electrically erasable programmable ROM (EEPROM), and the revision level of the firmware on the Remote Supervisor Adapter II SlimLine.

- **System Card Data**

Select this choice to view vital product data (VPD) for some server components.

- **Devices and I/O Ports**

Select this choice to view or change assignments for devices and input/output (I/O) ports.

Select this choice to enable or disable integrated SAS and Ethernet controllers and all standard ports (such as serial and parallel). **Enable** is the default setting for all controllers. If you disable a device, it cannot be configured, and the operating system will not be able to detect it (this is equivalent to disconnecting the device). If you disable the integrated Ethernet controller and no Ethernet adapter is installed, the server will have no Ethernet capability. If you disable the integrated USB controller, the server will have no USB capability; to maintain USB capability, make sure that **Enabled** is selected for the **USB Host Controller** and **USB BIOS Legacy Support** options.

Note: If the USB host controller is disabled, the Remote Supervisor Adapter II SlimLine remote keyboard, remote mouse, remote disk, OS watchdog, and in-band management functions are also disabled.

This choice is on the full Configuration/Setup Utility menu only.

- **Date and Time**

Select this choice to set the date and time in the server, in 24-hour format (*hour:minute:second*).

This choice is on the full Configuration/Setup Utility menu only.

- **System Security**

Select this choice to set passwords. See “Passwords” on page 62 for more information about passwords. You can also enable the chassis-intrusion detector to alert you each time the server cover is removed.

This choice is on the full Configuration/Setup Utility menu only.

- **Power-on Password**

Select this choice to set or change a power-on password. See “Power-on password” on page 62 for more information.

- **Administrator Password**

Attention: If you set an administrator password and then forget it, there is no way to change, override, or remove it. You must replace the I/O board.

Select this choice to set or change an administrator password. An administrator password is intended to be used by a system administrator; it limits access to the full Configuration/Setup Utility menu. If an administrator password is set, the full Configuration/Setup Utility menu is available only if you type the administrator password at the password prompt. See “Administrator password” on page 63 for more information.

This choice is on the Configuration/Setup Utility menu only if an IBM Remote Supervisor Adapter II SlimLine is installed.

- **Start Options**

Select this choice to view or change the start options. Changes in the start options take effect when you restart the server.

You can specify whether the server starts with the keyboard number lock on or off. You can enable the server to run without a diskette drive, monitor, or keyboard.

The startup sequence specifies the order in which the server checks devices to find a boot record. The server starts from the first boot record that it finds. If the server has Wake on LAN hardware and software and the operating system supports Wake on LAN functions, you can specify a startup sequence for the Wake on LAN functions.

If you enable the boot fail count, the BIOS default settings will be restored after three consecutive failures to find a boot record.

You can enable a virus-detection test that checks for changes in the boot record when the server starts.

You can enable the use of a USB legacy keyboard in a DOS or System Setup environment. If a keyboard is detected, the USB legacy operation will be disabled.

This choice is on the full Configuration/Setup Utility menu only.

- **Advanced Setup**

Select this choice to change settings for advanced hardware features.

Important: The server might malfunction if these options are incorrectly configured. Follow the instructions on the screen carefully.

This choice is on the full Configuration/Setup Utility menu only.

- **System Partition Visibility**

Select this choice to specify whether the system partition is visible or hidden.

- **Memory Settings**

Select this choice to manually enable a pair of memory connectors. If a memory error is detected during POST or memory configuration, the server automatically disables the failing pair of memory connectors and continues operating with reduced memory. After the problem is corrected, you must manually enable memory connectors. Use the arrow keys to highlight the pair of memory connectors that you want to enable, and use the arrow keys to select **Enable**.

- **Memory hole remapping above 64 GB**

Select **Disable** to prevent memory gap remapping above 64 GB. **Enable** is the default setting. Memory gap remapping above 64 GB occurs when 64 GB of system memory is installed. The memory gap created for use by I/O devices is reclaimed above 64 GB.

- **CPU Options**

Select this choice to enable or disable the Hyper-Threading Technology and to select the clustering technology settings.

- **PCI Slot/Device Information**

Select this choice to view system resources that are used by installed PCI/PCI-X devices. PCI/PCI-X devices are usually configured automatically. This information is saved when you exit. The **Save Settings**, **Restore Settings**, and **Load Default Settings** choices on the Configuration/Setup Utility main menu do not save the PCI Slot/Device Information settings.

This selection is only available when a Remote Supervisor II Adapter SlimLine is installed in the server.

- **RSA II Settings**

Select this choice to view and change Remote Supervisor Adapter II SlimLine settings. Select **Save Values and Reboot RSA II** to save the changes you have made in the settings and restart the Remote Supervisor Adapter II SlimLine.

- **Baseboard management controller (BMC) settings**
Select this choice to view information and to change baseboard management controller (BMC) settings.
 - **BMC firmware Ver**
This is a nonselectable menu item that displays the BMC firmware version.
 - **BMC POST Watchdog**
Enable or disable the BMC POST watchdog. **Disable** is the default setting.
 - **BMC POST Watchdog Timeout**
Set the BMC POST watchdog timeout value. **5 minutes** is the default setting.
 - **System BMC Serial Port Sharing**
Enable or disable the system BMC serial port sharing. **Enable** is the default setting.
 - **BMC Serial Port Access Mode**
Share or disable the BMC serial port access mode. **Shared** is the default setting.
 - **Reboot system on NMI**
If you enable this option, the server automatically restarts 60 seconds after the service processor issues a nonmaskable interrupt (NMI) to the server. If you disable this option, the server does not restart. **Enable** is the default setting.
 - **BMC Network Configuration**
Select this choice to view the BMC Network Configuration information.
 - **BMC System Event Log**
Select this choice to view the BMC system event log, which contains all system error and warning messages that have been generated. Use the arrow keys to move between pages in the log. If an optional IBM Remote Supervisor Adapter II SlimLine is installed, the full text of the error messages is displayed; otherwise, the log contains only numeric error codes. Run the diagnostic program to get more information about error codes that occur. See the *Problem Determination and Service Guide* on the IBM System x Documentation CD for instructions. Select **Clear error logs** to clear the BMC system event log.
- **Error Logs**
Select this choice to view or clear error logs.
This choice is available on the full Configuration/Setup Utility menu only.
 - **POST Error Log**
Select this choice to view the three most recent error codes and messages that were generated during POST. Select **Clear error logs** to clear the POST error log.
- **Save Settings**
Select this choice to save the changes that you have made in the settings.
- **Restore Settings**
Select this choice to cancel the changes that you have made in the settings and restore the previous settings.
- **Load Default Settings**
Select this choice to cancel the changes you have made in the settings and restore the factory settings.
- **Exit Setup**

Select this choice to exit from the Configuration/Setup Utility program. If you have not saved the changes you have made in the settings, you are asked whether you want to save the changes or exit without saving them.

Passwords

From the **System Security** choice, you can set, change, and delete a power-on password and an administrator password. The **System Security** choice is on the full Configuration/Setup menu only.

If you set only a power-on password, you must type the power-on password to complete the system startup, and you have access to the full Configuration/Setup Utility menu.

An administrator password is intended to be used by a system administrator; it limits access to the full Configuration/Setup Utility menu. If you set only an administrator password, you do not have to type a password to complete the system startup, but you must type the administrator password to access the Configuration/Setup Utility menu.

If you set a power-on password for a user and an administrator password for a system administrator, you can type either password to complete the system startup. A system administrator who types the administrator password has access to the full Configuration/Setup Utility menu; the system administrator can give the user authority to set, change, and delete the power-on password. A user who types the power-on password has access to only the limited Configuration/Setup Utility menu; the user can set, change, and delete the power-on password, if the system administrator has given the user that authority.

Power-on password

If a power-on password is set, when you turn on the server, the system startup will not be completed until you type the power-on password. You can use any combination of up to seven characters (A–Z, a–z, and 0–9) for the password.

When a power-on password is set, you can enable the Unattended Start mode, in which the keyboard and mouse remain locked but the operating system can start. You can unlock the keyboard and mouse by typing the power-on password.

If you forget the power-on password, you can regain access to the server in any of the following ways:

- If an administrator password is set, type the administrator password at the password prompt. Start the Configuration/Setup Utility program and reset the power-on password.
- Remove the battery from the server and then reinstall it. See "Replacing the battery" in the *Problem Determination and Service Guide* for instructions for removing the battery.
- Change the position of the power-on password override jumper (J9 on the I/O board) to bypass the power-on password check.

Attention: Before changing any switch settings or moving any jumpers, turn off the server; then, disconnect all power cords and external cables. See the safety information beginning on page v. Do not change settings or move jumpers on any system-board switch or jumper blocks that are not shown in this document.

The following illustration shows the location of the power-on password override, boot recovery, and Wake on LAN (WOL) bypass jumpers.

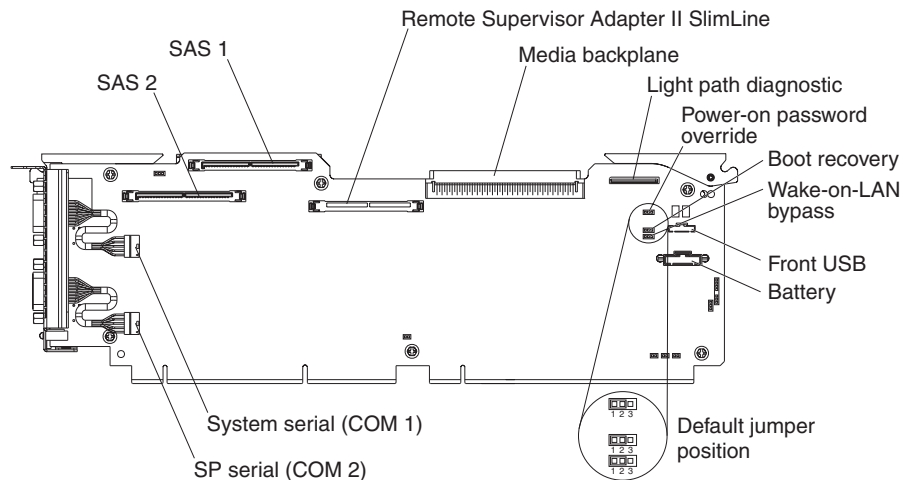

While the server is turned off, move the jumper on J9 from pins 1 and 2 to pins 2 and 3. You can then start the Configuration/Setup Utility program and reset the power-on password. After you reset the password, turn off the server again and move the jumper back to pins 1 and 2.

The power-on password override switch does not affect the administrator password.

Administrator password

If an administrator password is set, you must type the administrator password for access to the full Configuration/Setup Utility menu. You can use any combination of up to seven characters (A–Z, a–z, and 0–9) for the password. The **Administrator Password** choice is on the Configuration/Setup Utility menu only if an optional IBM Remote Supervisor Adapter II SlimLine is installed.

Attention: If you set an administrator password and then forget it, there is no way to change, override, or remove it. You must replace the I/O board.

Using the ServerGuide Setup and Installation CD

The *ServerGuide Setup and Installation* CD includes an easy-to-use setup and installation program that is designed for your IBM server. The ServerGuide program detects the server model and hardware options that are installed and uses that information during setup to configure the hardware. The ServerGuide program simplifies operating-system installations by providing updated device drivers and, in some cases, installing them automatically.

Note: The ServerGuide program works only with 32-bit Windows operating systems.

If a later version of the ServerGuide program is available, you can download a free image of the *ServerGuide Setup and Installation* CD, or you can purchase the CD. To download the image, go to the IBM ServerGuide Web page at <http://www.ibm.com/pc/qtechinfo/MIGR-4ZKPPT.html>. To purchase the latest *ServerGuide Setup and Installation* CD, go to the ServerGuide fulfillment Web site at http://www.ibm.com/servers/eserver/xseries/systems_management/serverguide/sub.html.

The ServerGuide program has the following features to make setup easier:

- An easy-to-use interface

- Diskette-free setup, and configuration programs that are based on detected hardware
- ServeRAID Manager program, which configures your ServeRAID adapter or integrated SCSI controller with RAID capabilities
- Device drivers that are provided for the server model and detected hardware
- Operating-system partition size and file-system type that are selectable during setup

ServerGuide features

Features and functions can vary slightly with different versions of the ServerGuide program. To learn more about the version that you have, start the *ServerGuide Setup and Installation* CD and view the online overview. Not all features are supported on all server models.

The ServerGuide program requires a supported IBM server with an enabled startable (bootable) CD-ROM drive. In addition to the *ServerGuide Setup and Installation* CD, you must have your operating-system CD to install your operating system.

The ServerGuide program has the following features:

- Sets system date and time
- Detects the SCSI RAID adapter, controller, and runs the SCSI RAID configuration program (with LSI chip sets for ServeRAID adapters only)
- Checks the microcode (firmware) levels of a ServeRAID adapter and determines whether a later level is available from the CD
- Detects installed hardware options and provides updated device drivers for most adapters and devices
- Provides diskette-free installation for supported Windows operating systems
- Includes an online readme file with links to tips for your hardware and operating-system installation

Setup and configuration overview

When you use the *ServerGuide Setup and Installation* CD, you do not need setup diskettes. You can use the CD to configure any supported IBM server model. The setup program provides a list of tasks that are required to set up the server model. On a server with a ServeRAID adapter, you can run the SCSI RAID configuration program to create logical drives.

Note: Features and functions can vary slightly with different versions of the ServerGuide program.

When you start the *ServerGuide Setup and Installation* CD, the program prompts you to complete the following tasks:

- Select your language.
- Select your keyboard layout and country.
- View the overview to learn about ServerGuide features.
- View the readme file to review installation tips for your operating system and adapter.
- Start the operating-system installation. You will need your operating-system CD.

Typical operating-system installation

You can use the ServerGuide program to shorten your installation time. The ServerGuide program provides the device drivers that are required for your hardware and for the operating system that you are installing. This section describes a typical ServerGuide operating-system installation.

Note: Features and functions can vary slightly with different versions of the ServerGuide program.

1. After you have completed the setup process, the operating-system installation program starts. (You will need your operating-system CD to complete the installation.)
2. The ServerGuide program stores information about the server model, service processor, hard disk drive controllers, and network adapters. Then, the program checks the CD for newer device drivers. This information is stored and then passed to the operating-system installation program.
3. The ServerGuide program presents operating-system partition options that are based on your operating-system selection and the installed hard disk drives.
4. The ServerGuide program prompts you to insert your operating-system CD and restart the server. At this point, the installation program for the operating system takes control to complete the installation.

Installing your operating system without ServerGuide

If you have already configured the server hardware and you decide not to use the ServerGuide program to install your operating system, complete the following steps to download the latest operating-system installation instructions from the IBM Support Web page:

1. Go to <http://www.ibm.com/servers/eserver/support/xseries/index.html>.
2. In the **Download** section, click **Downloads & drivers**.
3. On the “Downloads and drivers” page, in the **Brand** field, select **Servers**.
4. In the **Family** field, select **System x3950**.
5. Click **Continue**.
6. In the **View by document type** field, select **OS installation**.
7. Select the instructions for your operating system.

Using the Boot Menu program

The Boot Menu program is a built-in configuration program that you can use to temporarily redefine the first startup device without changing settings in the Configuration/Setup Utility program.

To use the Boot Menu program, complete the following steps:

1. Turn off the server.
2. Restart the server.
3. Press F12.
4. Select the startup device.

The next time the server is started, it returns to the startup sequence that is set in the Configuration/Setup Utility program.

Configuring the Gigabit Ethernet controller

The Ethernet controller is integrated on the I/O board. It provides an interface for connecting to a 10-Mbps, 100-Mbps, or 1-Gbps network and provides full-duplex (FDX) capability, which enables simultaneous transmission and reception of data on the network. If the Ethernet ports in the server support auto-negotiation, the controller detects the data-transfer rate (10BASE-T, 100BASE-TX, or 1000BASE-T) and duplex mode (full-duplex or half-duplex) of the network and automatically operates at that rate and mode.

You do not have to set any jumpers or configure the controller. However, you must install a device driver to enable the operating system to address the controller. Install the device drivers from the *Broadcom NetXtreme Gigabit Ethernet Software CD* that comes with the server. For information about configuring the Ethernet controller, see the *Broadcom NetXtreme Gigabit Ethernet Software CD*. For updated information about configuring the controller, see <http://www.ibm.com/servers/eserver/support/xseries/index.html>.

Using the PXE boot agent utility program

Use the Preboot Execution Environment (PXE) boot agent utility program to enable or disable operating-system wake-up support.

Note: Your server does not support changing the network boot protocol or specifying the startup order of devices through the PXE boot agent utility program.

Starting the PXE boot agent utility program

To start the PXE boot agent utility program, complete the following steps:

1. Turn on the server.
2. When the Broadcom NetXtreme Ethernet Boot Agent Version X.X.XX prompt appears, press Ctrl+S. You have 2 seconds (by default) to press Ctrl+S after the prompt appears.

Note: If the prompt is not displayed, use the Configuration/Setup Utility program to set the Ethernet PXE startup option.

3. To select a choice from the menu, use the arrow keys and press Enter.
4. To change the setting of the selected item, follow the instructions on the screen.

PXE boot agent utility menu choices

The following choices are on the PXE boot agent utility menu:

- **Boot Protocol**
PXE is the default setting. Do not change this setting; the server does not support any other network boot protocols.
- **Boot Strap Type**
Select this choice to specify the type of boot strap. You can select Auto Detect (the default), BBS, Int18h, or Int19h.
- **Hide Setup Prompt**
Select this choice to enable or disable the PXE setup prompt. **Disable** is the default setting. When the prompt is enabled, the prompt Press Ctrl+S to enter the setup menu appears under the initializing prompt.
- **Setup Key Stroke**

Select this choice to specify the key strokes to start the PXE boot agent utility. You can select Ctrl+S (default), or Ctrl+B.

- **Banner Message Timeout**

Select this choice to specify the amount of time (in seconds) that the server will wait for you to press Ctrl+S after the prompt appears. You can select 2 (default), 3, 5, or 8 seconds.

- **Link Speed**

Select this choice to set the link speed for the LAN connection. **AutoNeg** (auto-negotiate) is the default setting.

- **Pre-boot Wake on LAN**

Select this choice to enable or disable the pre-boot Wake on LAN feature. **Enable** is the default setting

If you are using an Advanced Configuration and Power Interface (ACPI) aware operating system, such as Microsoft Windows 2000, disable this choice to use Wake on LAN support. Otherwise, enable it.

If you are using a non-ACPI-aware operating system, do not send wake-up packets to the server while it is turned on. If you send a wake-up packet to the server while it is turned on and you are then unable to turn off the server, see “Power problems” in the *Problem Determination and Service Guide* on the IBM System x Documentation CD.

Installing and using the baseboard management controller utility programs

The baseboard management controller provides environmental monitoring for the server. If environmental conditions exceed thresholds or if system components fail, the baseboard management controller lights LEDs to help you diagnose the problem and also records the error in the BMC system event log.

The baseboard management controller also provides the following remote server management capabilities through the OSA SMBridge management utility program:

- **Command-line interface (IPMI Shell)**

The command-line interface provides direct access to server management functions through the IPMI 2.0 protocol. Use the command-line interface to issue commands to control the server power, view system information, and identify the server. You can also save one or more commands as a text file and run the file as a script.

- **Serial over LAN**

Establish a Serial over LAN (SOL) connection to manage servers from a remote location. You can remotely view and change the BIOS settings, restart the server, identify the server, and perform other management functions. Any standard Telnet client application can access the SOL connection.

Note: The server Ethernet ports are set to DHCP by default. The BMC MAC address can be found on a tag on the front of the server. Once you have deployed the server, remove the tag so that it does not impede airflow through the front of the server.

For more information about IPMI 2.0, see the *Intelligent Platform Management Interface Specification (IPMI Specification)*, version 2.0, available at <http://www.intel.com>.

Enabling and configuring SOL using the OSA SMBridge management utility program

To enable and configure the server for SOL by using the OSA SMBridge management utility program, you must update and configure the BIOS code and enable the operating system for an SOL connection.

Updating and configuring the BIOS

To update and configure the BIOS code to enable SOL, complete the following steps.

1. Update the BIOS code:
 - a. Download the latest version of the BIOS code from <http://www.ibm.com/servers/eserver/support/xseries/index.html>.
 - b. Update the BIOS code, following the instructions that come with the update file that you downloaded.
2. Configure the BIOS settings:
 - a. Restart the server and press F1 when prompted to start the Configuration/Setup Utility program.
 - b. Select **Devices and I/O Ports**; then, make sure that the values are set as follows:
 - **Serial Port A**: Auto-configure
 - **Serial Port B**: Auto-configure
 - c. Select **Remote Console Redirection**; then, make sure that the values are set as follows:
 - **Remote Console Active**: Enabled
 - **Remote Console COM Port**: COM 2
 - **Remote Console Baud Rate**: 19200
 - **Remote Console Data Bits**: 8
 - **Remote Console Parity**: None
 - **Remote Console Stop Bits**: 1
 - **Remote Console Text Emulation**: ANSI
 - **Remote Console Keyboard Emulation**: ANSI
 - **Remote Console Active After Boot**: Enabled
 - **Remote Console Flow Control**: Hardware
 - d. Press Esc twice to exit the **Remote Console Redirection** and **Devices and I/O Ports** sections of the Configuration/Setup Utility program.

Note: Do not use Planar Ethernet 1 for PXE/DHCP booting or installation.
 - e. Select **Start Options**; then, set **Planar Ethernet PXE/DHCP** to one of the following settings:
 - **Disabled**
 - **Planar Ethernet 2**. If you set **Planar Ethernet PXE/DHCP** to **Planar Ethernet 2**, you must also set **Run PXE only on selected Planar NIC** to **Enabled**.
 - f. Press Esc to exit the **Start Options** section of the Configuration/Setup Utility program.
 - g. Select **Save Settings**; then, press Enter.
 - h. Press Enter to confirm.
 - i. Select **Exit Setup**; then, press Enter.

- j. Make sure that **Yes, exit the Setup Utility** is selected; then, press Enter.

Configuring Linux

For SOL operation on the server, you must configure the Linux operating system to expose the Linux initialization (booting) process. This enables users to log in to the Linux console through an SOL session and directs Linux output to the serial console. See the documentation for your specific Linux operating-system type for information and instructions.

Use one of the following procedures to enable SOL sessions for your Linux operating system. You must be logged in as a root user to perform these procedures.

Configuring Red Hat Enterprise Linux ES 2.1:

Note: This procedure is based on a default installation of Red Hat Enterprise Linux ES 2.1. The file names, structures, and commands might be different for other versions of Red Hat Linux.

To configure the general Linux parameters for SOL operation when using the Red Hat Enterprise Linux ES 2.1 operating system, complete the following steps.

Note: Hardware flow control prevents character loss during communication over a serial connection. You must enable it when using a Linux operating system.

1. Add the following line to the end of the # Run gettys in standard runlevels section of the `/etc/inittab` file. This enables hardware flow control and enables users to log in through the SOL console.

```
7:2345:respawn:/sbin/agetty -h ttyS1 19200 vt102
```
2. Add the following line at the bottom of the `/etc/securetty` file to enable a user to log in as the root user through the SOL console:

```
ttyS1
```

LILO configuration: If you are using LILO, complete the following steps:

1. Modify the `/etc/lilo.conf` file:
 - a. Add the following text to the end of the first `default=linux` line:

```
-Monitor
```
 - b. Comment out the `map=/boot/map` line by adding a # at the beginning of the line.
 - c. Comment out the `message=/boot/message` line by adding a # at the beginning of the line.
 - d. Add the following line before the first `image=` line:

```
# This will allow you to only Monitor the OS boot via SOL
```
 - e. Add the following text to the end of the first `label=linux` line:

```
-Monitor
```
 - f. Add the following line to the first `image=` section. This enables SOL.

```
append="console=ttyS1,19200n8 console=tty1"
```
 - g. Add the following lines between the two `image=` sections:

```
# This will allow you to Interact with the OS boot via SOL
image=/boot/vmlinuz-2.4.9-e.12smp
    label=linux-Interact
    initrd=/boot/initrd-2.4.9-e.12smp.img
    read-only
```

```
root=/dev/hda6
```

```
append="console=tty1 console=ttyS1,19200n8 "
```

The following examples show the original content of the `/etc/lilo.conf` file and the content of this file after modification.

Original `/etc/lilo.conf` contents

```
prompt
timeout=50
default=linux
boot=/dev/hda
map=/boot/map
install=/boot/boot.b
message=/boot/message
linear
image=/boot/vmlinuz-2.4.9-e.12smp
    label=linux
    initrd=/boot/initrd-2.4.9-e.12smp.img
    read-only
    root=/dev/hda6
image=/boot/vmlinuz-2.4.9-e.12
    label=linux-up
    initrd=/boot/initrd-2.4.9-e.12.img
    read-only
    root=/dev/hda6
```

Modified /etc/lilo.conf contents

```
prompt
timeout=50
default=linux-Monitor
boot=/dev/hda
#map=/boot/map
install=/boot/boot.b
#message=/boot/message
linear
# This will allow you to only Monitor the OS boot via SOL
image=/boot/vmlinuz-2.4.9-e.12smp
    label=linux-Monitor
    initrd=/boot/initrd-2.4.9-e.12smp.img
    read-only
    root=/dev/hda6
    append="console=ttyS1,19200n8 console=tty1"
# This will allow you to Interact with the OS boot via SOL
image=/boot/vmlinuz-2.4.9-e.12smp
    label=linux-Interact
    initrd=/boot/initrd-2.4.9-e.12smp.img
    read-only
    root=/dev/hda6
    append="console=tty1 console=ttyS1,19200n8 "
image=/boot/vmlinuz-2.4.9-e.12
    label=linux-up
    initrd=/boot/initrd-2.4.9-e.12.img
    read-only
    root=/dev/hda6
```

2. Run the **lilo** command to store and activate the LILO configuration.

When the Linux operating system starts, a LILO boot: prompt is displayed instead of the graphical user interface. Press Tab at this prompt to install all of the boot options that are listed. To load the operating system in interactive mode, type linux-Interact and press Enter.

GRUB configuration: If you are using GRUB, complete the following steps to modify the /boot/grub/grub.conf file:

1. Comment out the splashimage= line by adding a # at the beginning of this line.
2. Add the following line before the first title= line:
This will allow you to only Monitor the OS boot via SOL
3. Append the following text to the first title= line:
SOL Monitor
4. Append the following text to the kernel/ line of the first title= section:
console=ttyS1,19200 console=tty1
5. Add the following five lines between the two title= sections:
This will allow you to Interact with the OS boot via SOL
title Red Hat Linux (2.4.9-e.12smp) SOL Interactive
root (hd0,0)

```
kernel /vmlinuz-2.4.9-e.12smp ro root=/dev/hda6 console=tty1
console=ttyS1,19200
initrd /initrd-2.4.9-e.12smp.img
```

Note: The entry that begins with `kernel /vmlinuz` is shown with a line break after `console=tty1`. In your file, the entire entry must all be on one line.

The following examples show the original content of the `/boot/grub/grub.conf` file and the content of this file after modification.

Original `/boot/grub/grub.conf` contents

```
#grub.conf generated by anaconda
#
# Note that you do not have to rerun grub after making changes to this file
# NOTICE: You have a /boot partition. This means that
#         all kernel and initrd paths are relative to /boot/, eg.
#         root (hd0,0)
#         kernel /vmlinuz-version ro root=/dev/hda6
#         initrd /initrd-version.img
#boot=/dev/hda
default=0
timeout=10
splashimage=(hd0,0)/grub/splash.xpm.gz
title Red Hat Enterprise Linux ES (2.4.9-e.12smp)
    root (hd0,0)
    kernel /vmlinuz-2.4.9-e.12smp ro root=/dev/hda6
    initrd /initrd-2.4.9-e.12smp.img
title Red Hat Enterprise Linux ES-up (2.4.9-e.12)
    root (hd0,0)
    kernel /vmlinuz-2.4.9-e.12 ro root=/dev/hda6
    initrd /initrd-2.4.9-e.12.img
```

Modified /boot/grub/grub.conf contents

```
#grub.conf generated by anaconda
#
# Note that you do not have to rerun grub after making changes to this file
# NOTICE: You have a /boot partition. This means that
#         all kernel and initrd paths are relative to /boot/, eg.
#         root (hd0,0)
#         kernel /vmlinuz-version ro root=/dev/hda6
#         initrd /initrd-version.img
#boot=/dev/hda
default=0
timeout=10
# splashimage=(hd0,0)/grub/splash.xpm.gz
# This will allow you to only Monitor the OS boot via SOL
title Red Hat Enterprise Linux ES (2.4.9-e.12smp) SOL Monitor
    root (hd0,0)
    kernel /vmlinuz-2.4.9-e.12smp ro root=/dev/hda6 console=ttyS1,19200 console=tty1
    initrd /initrd-2.4.9-e.12smp.img
# This will allow you to Interact with the OS boot via SOL
title Red Hat Linux (2.4.9-e.12smp) SOL Interactive
    root (hd0,0)
    kernel /vmlinuz-2.4.9-e.12smp ro root=/dev/hda6 console=tty1 console=ttyS1,19200
    initrd /initrd-2.4.9-e.12smp.img
title Red Hat Enterprise Linux ES-up (2.4.9-e.12)
    root (hd0,0)
    kernel /vmlinuz-2.4.9-e.12 ro root=/dev/hda6
    initrd /initrd-2.4.9-e.12.img
```

You must restart the Linux operating system after completing these procedures for the changes to take effect and to enable SOL.

SUSE SLES 8.0 configuration:

Note: This procedure is based on a default installation of SUSE Linux Enterprise Server (SLES) 8.0. The file names, structures, and commands might be different for other versions of SUSE Linux.

To configure the general Linux parameters for SOL operation with the SLES 8.0 operating system, complete the following steps.

Note: Hardware flow control prevents character loss during communication over a serial connection. You must enable it when using a Linux operating system.

1. Add the following line to the end of the # getty-programs for the normal runlevels section of the /etc/inittab file. This enables hardware flow control and enables users to log in through the SOL console.
7:2345:respawn:/sbin/agetty -h ttyS1 19200 vt102
2. Add the following line after the tty6 line at the bottom of the /etc/securetty file to enable a user to log in as the root user through the SOL console:
ttyS1
3. Complete the following steps to modify the /boot/grub/menu.lst file:

- a. Comment out the gfxmenu line by adding a # in front of the word gfxmenu.
- b. Add the following line before the first title line:
This will allow you to only Monitor the OS boot via SOL
- c. Append the following text to the first title line:
SOL Monitor
- d. Append the following text to the kernel line of the first title section:
console=ttyS1,19200 console=tty1
- e. Add the following four lines between the first two title sections:
This will allow you to Interact with the OS boot via SOL
title linux SOL Interactive
kernel (hd0,1)/boot/vmlinuz root=/dev/hda2 acpi=oldboot vga=791
console=tty1 console=ttyS1,19200
initrd (hd0,1)/boot/initrd

The following examples show the original content of the /boot/grub/menu.lst file and the content of this file after modification.

Original /boot/grub/menu.lst contents	Notes
<pre>gfxmanu (hd0,1)/boot/message color white/blue black/light-gray default 0 timeout 8 title linux kernel (hd0,1)/boot/vmlinuz root=/dev/hda2 acpi=oldboot vga=791 initrd (hd0,1)/boot/initrd title floppy root chainloader +1 title failsafe kernel (hd0,1)/boot/vmlinuz.shipped root=/dev/hda2 ide=nodma apm=off vga=normal nosmp disableapic maxcpus=0 3 initrd (hd0,1)/boot/initrd.shipped</pre>	<p>1</p> <p>1</p>
<p>Note 1: The kernel line is shown with a line break. In your file, the entire entry must all be on one line.</p>	

Modified /boot/grub/menu.lst contents	Notes
<pre>#gfxmanu (hd0,1)/boot/message color white/blue black/light-gray default 0 timeout 8 # This will allow you to only Monitor the OS boot via SOL title linux SOL Monitor kernel (hd0,1)/boot/vmlinuz root=/dev/hda2 acpi=oldboot vga=791 console=ttyS1,19200 console=tty1 initrd (hd0,1)/boot/initrd # This will allow you to Interact with the OS boot via SOL title linux SOL Interactive kernel (hd0,1)/boot/vmlinuz root=/dev/hda2 acpi=oldboot vga=791 console=tty1 console=ttyS1,19200 initrd (hd0,1)/boot/initrd title floppy</pre>	<p>1</p>

Modified /boot/grub/menu.lst contents	Notes
<pre> root chainloader +1 title failsafe kernel (hd0,1)/boot/vmlinuz.shipped root=/dev/hda2 ide=nodma apm=off vga=normal nosmp disableapic maxcpus=0 3 initrd (hd0,1)/boot/initrd.shipped </pre>	1
Note 1: The kernel line is shown with a line break. In your file, the entire entry must all be on one line.	

You must restart the Linux operating system after completing these procedures for the changes to take effect and to enable SOL.

Configuring a Microsoft Windows operating system

Complete the following steps to configure a Windows operating system for SOL operation. You must be logged in as a user with administrator access to perform this procedure.

1. Determine which boot entry ID to modify:
 - a. Type `bootcfg` at a Windows command prompt; then, press Enter to display the current boot options for the server.
 - b. In the Boot Entries section, locate the boot entry ID for the section with an OS friendly name of the Windows operating system. Write down the boot entry ID for use in the next step.
2. To enable the Microsoft Windows Emergency Management System (EMS), at a Windows command prompt, type

```
bootcfg /EMS ON /PORT COM1 /BAUD 19200 /ID boot_id
```

where *boot_id* is the boot entry ID from step 1b; then, press Enter.

3. To verify that the EMS console is redirected to the COM2 serial port:
 - a. Type `bootcfg` at a Windows command prompt; then, press Enter to display the current boot options for the server.
 - b. Verify the following changes to the bootcfg settings:
 - In the Boot Loader Settings section, make sure that `redirect` is set to `COM2` and that `redirectbaudrate` is set to `19200`.
 - In the Boot Entries section, make sure that the OS Load Options: line has `/redirect` appended to the end of it.

The following examples show the original bootcfg program output and the output after modification.

Original bootcfg program output
<pre> Boot Loader Settings ----- timeout: 30 default: multi(0)disk(0)rdisk(0)partition(1)\WINDOWS Boot Entries ----- Boot entry ID: 1 OS Friendly Name: Windows Server 2003, Standard Path: multi(0)disk(0)rdisk(0)partition(1)\WINDOWS OS Load Options: /fastdetect </pre>

Modified bootcfg program output

```
Boot Loader Settings
-----
timeout: 30
default: multi(0)disk(0)rdisk(0)partition(1)\WINDOWS
redirect: COM1
redirectbaudrate: 19200
Boot Entries
-----
Boot entry ID: 1
OS Friendly Name: Windows Server 2003, Standard
Path: multi(0)disk(0)rdisk(0)partition(1)\WINDOWS
OS Load Options: /fastdetect /redirect
```

You must restart the Windows 2003 operating system after completing this procedure for the changes to take effect and to enable SOL.

Installing the OSA SMBridge management utility program

Complete the following steps to install the OSA SMBridge management utility program on a server running a Windows operating system:

1. Go to <http://www.ibm.com/servers/eserver/support/xseries/index.html>, download the utility program, and create the OSA BMC Management Utility CD.
2. Insert the OSA BMC Management Utility CD into the drive. The InstallShield wizard starts, and a window similar to that shown in the following illustration opens.

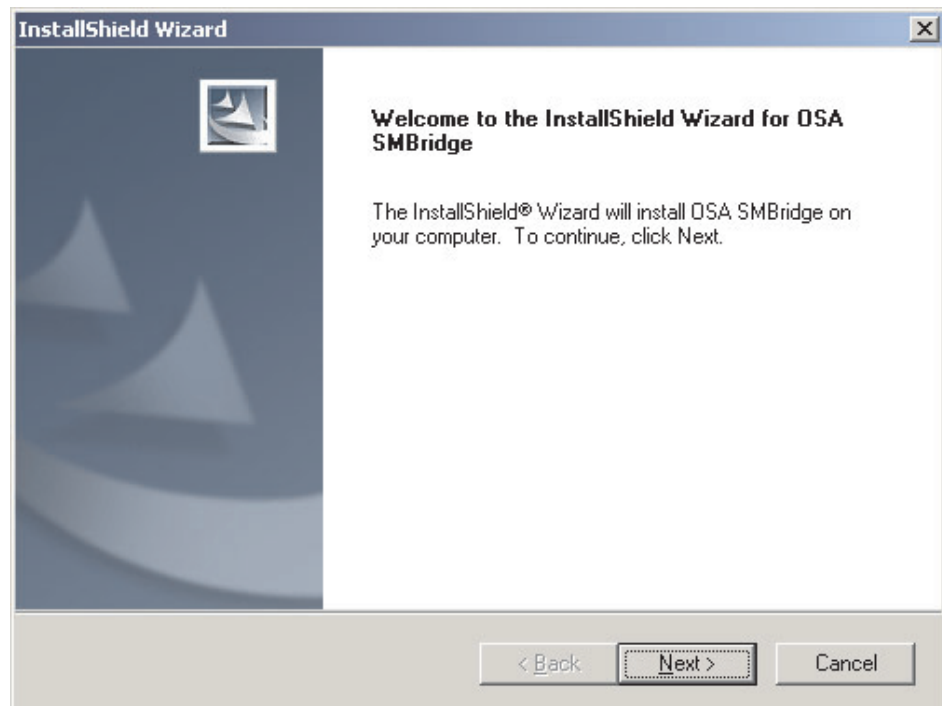

3. Follow the prompts to complete the installation.

The installation program prompts you for a TCP/IP port number and an IP address. Specify an IP address, if you want to limit the connection requests that will be accepted by the utility program. To accept connections from any server, type `INADDR_ANY` as the IP address. Also specify the port number that the utility program will use. These values will be recorded in the `smbridge.cfg` file for the automatic startup of the utility program.

To install the OSA SMBridge management utility program on a server running a Linux operating system, complete the following steps. You must be logged in as a root user to perform these procedures.

1. Go to <http://www.ibm.com/servers/eserver/support/xseries/index.html>, download the utility program, and create the OSA BMC Management Utility CD.
2. Insert the OSA BMC Management Utility CD into the drive.
3. Type `mount/mnt/cdrom`.
4. Locate the directory where the installation RPM package is located and type `cd/mnt/cdrom`.
5. Type the following command to run the RPM package and start the installation:

```
rpm -ivh smbridge-2.0-xx.rpm
```

where `xx` is the release level being installed.

6. Follow the prompts to complete the installation. When the installation is complete, the utility copies files to the following directories:
`/etc/init.d/SMBridge`
`/etc/smbridge.cfg`
`/usr/sbin/smbridged`
`/var/log/smbridge/License.txt`
`/var/log/smbridge/Readme.txt`

The utility starts automatically when the server is started. You can also locate the `/ect/init.d` directory to start the utility and use the following commands to manage the utility:

```
smbridge status  
smbridge start  
smbridge stop  
smbridge restart
```

Using the baseboard management controller utility programs

Use the baseboard management controller utility programs to configure the baseboard management controller, download firmware updates and SDR/FRU updates, and remotely manage a network.

Using the baseboard management controller configuration utility program

Use the baseboard management controller configuration utility program to view or change the baseboard management controller configuration settings. You can also use the utility program to save the configuration to a file for use on multiple servers.

Go to <http://www.ibm.com/servers/eserver/support/xseries/index.html> to download the utility program; then, copy the `bmc_cfg.exe` file to a configuration utility diskette on a USB connected diskette drive.

To start the baseboard management controller configuration utility program, complete the following steps:

1. Insert the configuration utility diskette into the USB diskette drive and restart the server.
2. From a command-line prompt, type `bmc_cfg` and press Enter.
3. Follow the instructions on the screen.

Using the baseboard management controller firmware update utility program

Use the baseboard management controller firmware update utility program to download a baseboard management controller firmware update. The firmware update utility program updates the baseboard management controller firmware only and does not affect any device drivers.

Note: To ensure proper server operation, be sure to update the server baseboard management controller firmware before updating the BIOS code.

To update the firmware, download the Linux or Windows operating-system update package that is available from <http://www.ibm.com/servers/eserver/support/xseries/index.html>. If you have installed the OSA device driver and IBM Mapping layer, the update can be done without a reboot. Otherwise, extract to a firmware update diskette on a USB diskette drive and reboot.

Using the OSA SMBridge management utility program

Use the OSA SMBridge management utility program to remotely manage and configure a network. The utility program provides the following remote management capabilities:

- **CLI (command-line interface) mode**

Use CLI mode to remotely perform power-management and system identification control functions over a LAN or serial port interface from a command-line interface. Use CLI mode also to remotely view the BMC system event log.

Use the following commands in CLI mode:

- **identify**

Control the system-locator LED on the front of the server.

- **power**

Turn the server on and off remotely.

- **sel**

Perform operations with the BMC system event log.

- **sysinfo**

Display general system information that is related to the server and the baseboard management controller.

- **Serial over LAN**

Use the Serial over LAN capability to remotely perform control and management functions over a Serial over LAN (SOL) network. You can also use SOL to remotely view and change the server BIOS settings.

At a command prompt, type `telnet localhost 623` to access the SOL network. Type `help` at the `smbridge>` prompt for more information.

Use the following commands in an SOL session:

- **connect**

Connect to the LAN. Type `connect -ip ip_address -u username -p password`.

- **identify**

Control the system-locator LED on the front of the server.

- **power**
Turn the server on and off remotely.
- **reboot**
Force the server to restart.
- **sel get**
Display the BMC system event log.
- **sol**
Configure the SOL function.
- **sysinfo**
Display system information that is related to the server and the globally unique identifier (GUID).

Using the SAS/SATA Configuration Utility program

Use the SAS/SATA Configuration Utility program to configure SAS devices.

Starting the SAS/SATA Configuration Utility program

To start the SAS/SATA Configuration Utility program, complete the following steps:

1. Turn on the server.
2. When the prompt <<< Press <CTRL><A> for Adaptec SAS/SATA Configuration Utility! >>> appears, press Ctrl+A.
3. To select a choice from the menu, use the arrow keys.
4. Follow the instructions on the screen to change the SerialSelect Utility or Disk Utilities settings.

SerialSelect Utility menu choices

The following choices are on the SerialSelect Utility menu:

- **SAS Controller Configuration**
Select this choice to view or change SAS controller settings. To reset the controller to its default settings, press F6 and follow the instructions on the screen.
- **PHY Configuration**
Select this choice to view or change PHY configuration settings. To reset the controller to its default settings, press F6 and follow the instructions on the screen.

Disk Utilities

Select this choice to format, verify, or locate SAS devices. Select a device from the list and read the instructions on the screen carefully before making a selection.

Using ServeRAID Manager

Use ServeRAID Manager, which is on the *IBM ServeRAID Support CD*, to:

- Configure a redundant array of independent disks (RAID) array
- Restore a SCSI hard disk drive to the factory-default settings, erasing all data from the disk
- View the RAID configuration and associated devices
- Monitor the operation of the RAID controllers

To perform some tasks, you can run ServeRAID Manager as an installed program. However, to perform an initial RAID configuration on the server, you must run ServeRAID Manager in Startable CD mode, as described in the instructions in this section. If you install a different type of RAID adapter in the server, use the configuration method described in the instructions that come with that adapter to view or change SCSI settings for attached devices.

For additional information about RAID technology, see the ServeRAID documentation on the *IBM ServeRAID Support CD*. Additional information about ServeRAID Manager is also available from the **Help** menu. For information about a specific object in the ServeRAID Manager tree, select the object and click **Actions** ” **Hints and tips**.

Configuring the controller

By running ServeRAID Manager in Startable CD mode, you can configure the controller before you install the operating system. The information in this section assumes that you are running ServeRAID Manager in Startable CD mode.

To run ServeRAID Manager in Startable CD mode, turn on the server; then, insert the CD into the CD-ROM drive. If ServeRAID Manager detects an unconfigured controller and ready drives, the Configuration wizard starts.

In the Configuration wizard, you can select express configuration or custom configuration. Express configuration automatically configures the controller by grouping the first two physical drives in the ServeRAID Manager tree into an array and creating a RAID level-1 logical drive. If you select custom configuration, you can select the two physical drives that you want to group into an array and create a hot-spare drive.

Using express configuration

To use express configuration, complete the following steps:

1. In the ServeRAID Manager tree, click the controller.
2. Click **Express configuration**.
3. Click **Next**. The “Configuration summary” window opens.
4. Review the information in the “Configuration summary” window. To change the configuration, click **Modify arrays**.
5. Click **Apply**; when you are asked whether you want to apply the new configuration, click **Yes**. The configuration is saved in the controller and in the physical drives.
6. Exit from ServeRAID Manager and remove the CD from the CD-ROM drive.
7. Restart the server.

Using custom configuration

To use custom configuration, complete the following steps:

1. In the ServeRAID Manager tree, click the controller.
2. Click **Custom configuration**.
3. Click **Next**. The “Create arrays” window opens.
4. From the list of ready drives, select the two drives that you want to group into the array.
5. Click the icon to add the drives to the array.
6. If you want to configure a hot-spare drive, complete the following steps:
 - a. Click the **Spares** tab.

- b. Select the physical drive that you want to designate as the hot-spare drive, and click the icon to add the drive.
7. Click **Next**. The “Configuration summary” window opens.
8. Review the information in the “Configuration summary” window. To change the configuration, click **Back**.
9. Click **Apply**; when you are asked whether you want to apply the new configuration, click **Yes**. The configuration is saved in the controller and in the physical drives.
10. Exit from ServeRAID Manager and remove the CD from the CD-ROM drive.
11. Restart the server.

Viewing the configuration

You can use ServeRAID Manager to view information about RAID controllers and the RAID subsystem (such as arrays, logical drives, hot-spare drives, and physical drives). When you click an object in the ServeRAID Manager tree, information about that object appears in the right pane. To display a list of available actions for an object, click the object and click **Actions**.

Using the Scalable Partition Web Interface

The Scalable Partition Web Interface is an extension of the Remote Supervisor Adapter II SlimLine Web Interface and is used to create, delete, control, and view scalable partitions. The Scalable Partition Web Interface is in the Remote Supervisor Adapter II SlimLine integrated service processor.

The scalable partition defines a multi-node configuration, which interconnects two, four, or eight servers. The multi-node configuration provides the function to individually power-on and power-off each node. The multi-node configuration uses a single, contiguous memory space and provides access to all associated adapters. Each scalable system can have one or more scalable partitions.

Before you create or delete scalable partitions, read the following information:

- A Remote Supervisor Adapter II SlimLine must be installed in all nodes that are to become part of a scalable partition.
- All of the service processors must be connected to an Ethernet network through the SP connector on the rear of the node. This connection is needed so that the service processors can communicate with and manage scalable partitions.
- Make sure that all nodes in the multi-node configuration have the current level of BIOS code, SAS BIOS code, service processor firmware, BMC firmware, and CPLD firmware. The code and firmware levels must be the same for all nodes.
- When you set up the nodes for scalable partitions for the first time, you must first log on and configure the service processor in each node.
- PCI slot numbering starts with the primary node and continues with the secondary nodes, in numeric order of the logical node IDs.

Creating a scalable partition

To create a scalable partition, complete the following steps:

1. Make sure that the service processor on each node is configured and connected to the network. See the *Remote Supervisor Adapter II SlimLine and Remote Supervisor Adapter II User's Guide* for more information.

2. Make sure that all nodes in the multi-node configuration contain microprocessors that are the same cache size and type, and the same clock speed.
3. Connect the SMP Expansion cables. See “SMP Expansion cabling” on page 49 for instructions.
4. Connect all nodes to an ac power source and make sure that they are not running an operating system.
5. Access the network used by the multi-node configuration and connect and log in to the Remote Supervisor Adapter II Web Interface on the primary node. See the *Remote Supervisor Adapter II SlimLine and Remote Supervisor Adapter II User's Guide* for more information; then, continue with the procedure to create a scalable partition.

Note: The Remote Supervisor Adapter II Web Interface must be open to view, create, delete, or manage scalable partitions. Make sure that the Web Interface is open before you continue.

6. In the navigation pane, click **Status** under **Scalable Partitioning**. Use the Scalable Partition Status page to view information about the current and new scalable partitions. A page similar to the one in the following illustration is displayed.

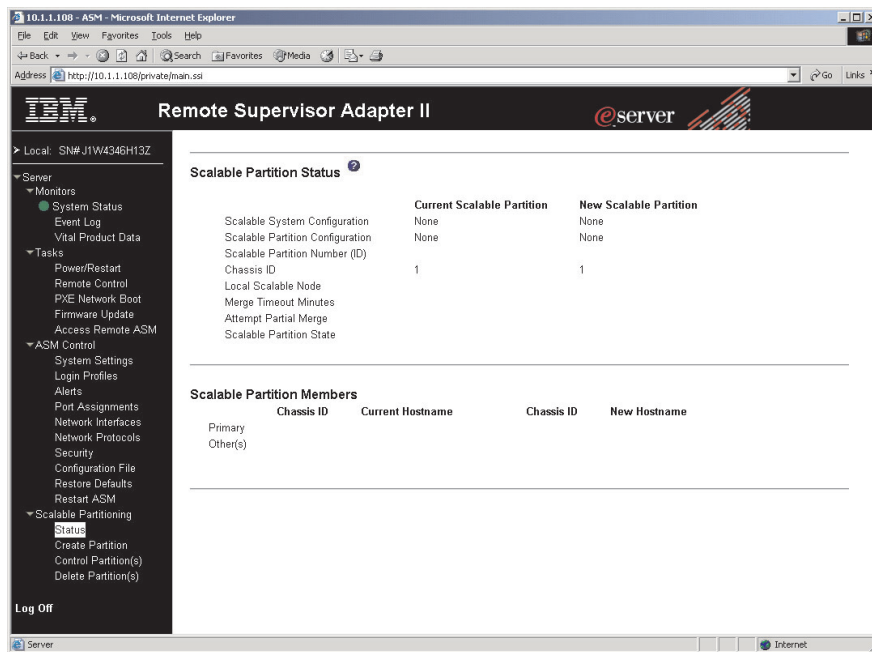

7. In the navigation pane, click **Create Partition**. Only perform this step if you are cabling the configuration or changing the host name. Use the Create Partition page to identify the nodes. A page similar to the one in the following illustration is displayed.

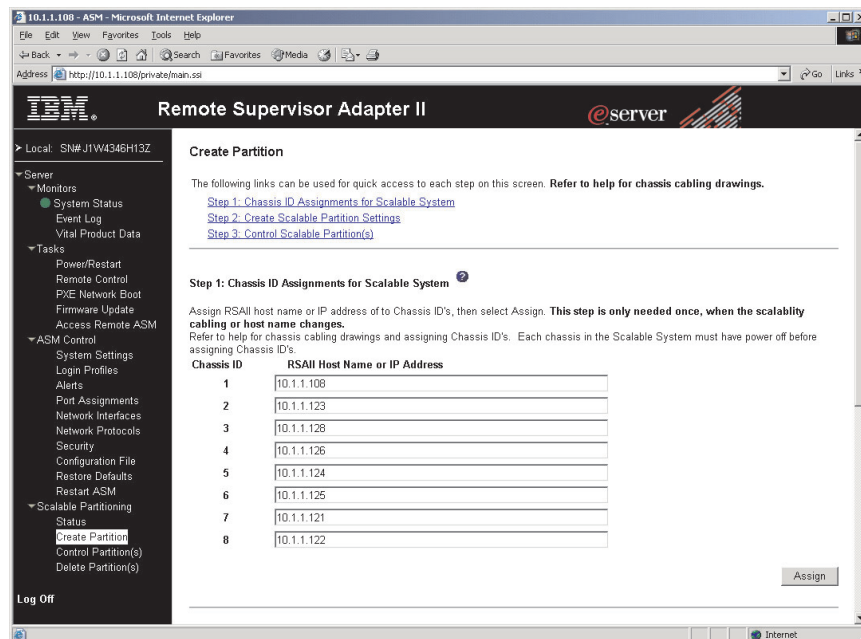

- a. In the **RSAll Host Name or IP Address** field, type the host name or Remote Supervisor Adapter II Slimline IP address for each node. The node is assigned the associated chassis ID.
- b. After you enter information for all nodes, click **Assign**.

8. Use the Create Scalable Partition Settings page to define the scalable partition. Perform this step to create a new partition. A page similar to the one in the following illustration is displayed.

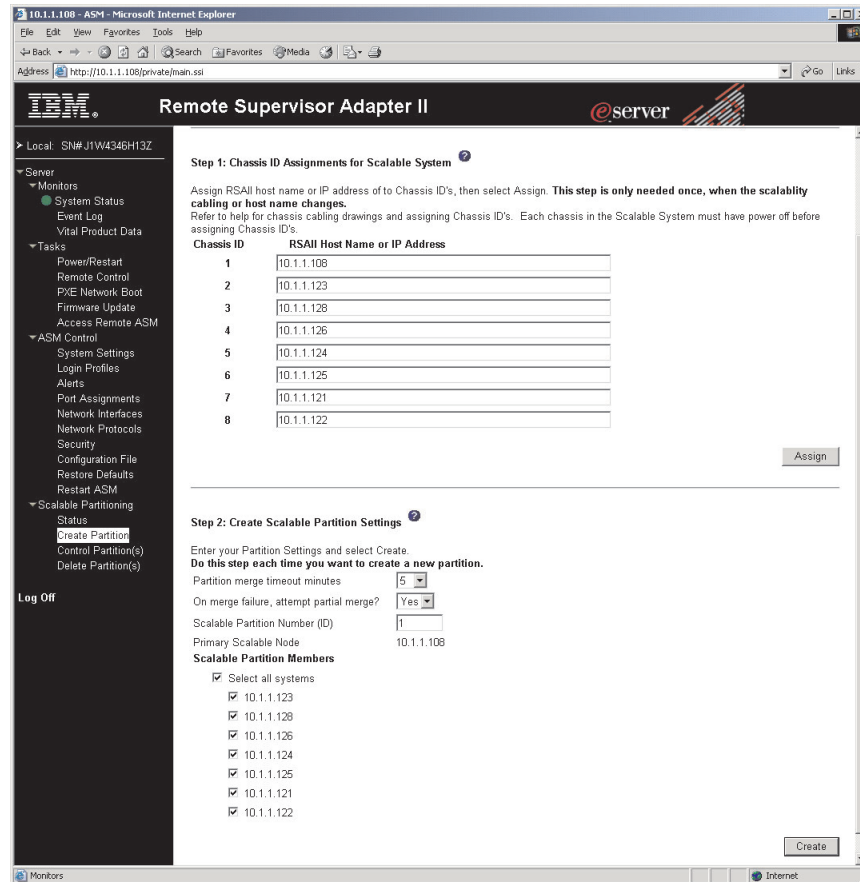

- a. In the **Partition merge timeout minutes** field, select the number of minutes POST waits for the scalable nodes to merge resources. Allow at least 8 seconds for each GB of memory in the scalable partition. You can view the merge status on the monitor attached to the primary node.
- b. In the **On merge failure, attempt partial merge?** field, select if POST should attempt a partial merge if one error is detected during full merge. You can view the merge status during POST on the monitor attached to the primary node.
- c. In the **Scalable Partition Number (ID)** field, type a unique identifier for this scalable partition.

Note: The **Primary Scalable Node** field displays the primary node chassis ID.

- d. In the **Scalable Partition Members** field, select the nodes that will be assigned to the scalable partition. You can select all nodes or select individual nodes.
- e. Click **Create**.

9. In the navigation pane, click **Control Partition** and follow the instructions on the Control Scalable Partition page to manage the scalable partition. Use the Control Scalable Partition page to replace a current scalable partition with a new scalable partition. You can also start or stop a scalable partition. A page similar to the one in the following illustration is displayed.

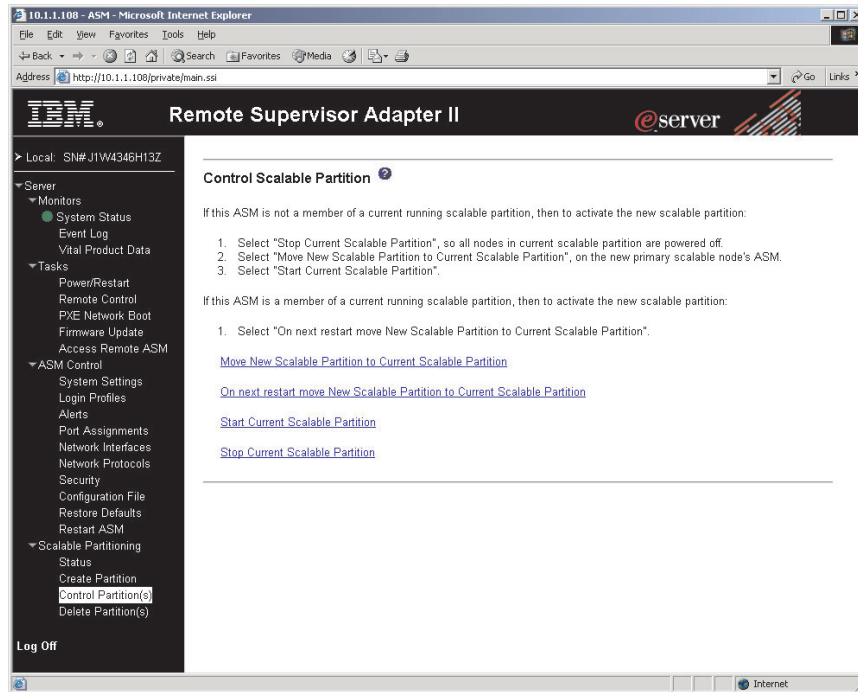

Deleting a scalable partition

To delete the scalable partition, complete the following steps:

1. Log in to the Remote Supervisor Adapter II Web Interface.
2. In the navigation pane, click **Scalable Partitioning**.
3. In the navigation pane, click **Delete Partition(s)**; then, follow the instructions on the Delete Scalable Partition page.

Chapter 4. Updating IBM Director

If you plan to use IBM Director to manage the server, you must check for the latest applicable IBM Director updates and interim fixes.

To install the IBM Director updates and any other applicable updates and interim fixes, complete the following steps.

Note: Changes are made periodically to the IBM Web site. The actual procedure might vary slightly from what is described in this document.

1. Check for the latest version of IBM Director:
 - a. Go to http://www.ibm.com/servers/eserver/xseries/systems_management/xseries_sm/dwnl.html.
 - b. If the drop-down list shows a newer version of IBM Director than what comes with the server, follow the instructions on the Web page to download the latest version.
2. Install IBM Director.
3. Download and install any applicable updates or interim fixes for the server:
 - a. Go to <http://www.ibm.com/servers/eserver/support/xseries/index.html>.
 - b. From the **Hardware** list, select **System x3950** or **System x3950 E** and click **Go**.
 - c. Click the **Download** tab.
 - d. Select any applicable update or interim fix that you want to download.
 - e. Click the link for the executable (.exe) file to download the file, and follow the instructions in the readme file to install the update or interim fix.

Appendix. Notices

This information was developed for products and services offered in the U.S.A.

IBM may not offer the products, services, or features discussed in this document in other countries. Consult your local IBM representative for information on the products and services currently available in your area. Any reference to an IBM product, program, or service is not intended to state or imply that only that IBM product, program, or service may be used. Any functionally equivalent product, program, or service that does not infringe any IBM intellectual property right may be used instead. However, it is the user's responsibility to evaluate and verify the operation of any non-IBM product, program, or service.

IBM may have patents or pending patent applications covering subject matter described in this document. The furnishing of this document does not give you any license to these patents. You can send license inquiries, in writing, to:

*IBM Director of Licensing
IBM Corporation
North Castle Drive
Armonk, NY 10504-1785
U.S.A.*

INTERNATIONAL BUSINESS MACHINES CORPORATION PROVIDES THIS PUBLICATION "AS IS" WITHOUT WARRANTY OF ANY KIND, EITHER EXPRESS OR IMPLIED, INCLUDING, BUT NOT LIMITED TO, THE IMPLIED WARRANTIES OF NON-INFRINGEMENT, MERCHANTABILITY OR FITNESS FOR A PARTICULAR PURPOSE. Some states do not allow disclaimer of express or implied warranties in certain transactions, therefore, this statement may not apply to you.

This information could include technical inaccuracies or typographical errors. Changes are periodically made to the information herein; these changes will be incorporated in new editions of the publication. IBM may make improvements and/or changes in the product(s) and/or the program(s) described in this publication at any time without notice.

Any references in this information to non-IBM Web sites are provided for convenience only and do not in any manner serve as an endorsement of those Web sites. The materials at those Web sites are not part of the materials for this IBM product, and use of those Web sites is at your own risk.

IBM may use or distribute any of the information you supply in any way it believes appropriate without incurring any obligation to you.

Trademarks

The following terms are trademarks of International Business Machines Corporation in the United States, other countries, or both:

Active Memory	IBM	TechConnect
Active PCI	IBM (logo)	Tivoli
Active PCI-X	IntelliStation	Tivoli Enterprise
AIX	NetBAY	Update Connector
Alert on LAN	Netfinity	Wake on LAN

BladeCenter	Predictive Failure Analysis	XA-32
Chipkill	ServeRAID	XA-64
e-business logo	ServerGuide	X-Architecture
@server	ServerProven	XpandOnDemand
FlashCopy	System x	xSeries
i5/OS		

Intel, Intel Xeon, Itanium, and Pentium are trademarks or registered trademarks of Intel Corporation or its subsidiaries in the United States and other countries.

Microsoft, Windows, and Windows NT are trademarks of Microsoft Corporation in the United States, other countries, or both.

UNIX is a registered trademark of The Open Group in the United States and other countries.

Java and all Java-based trademarks and logos are trademarks of Sun Microsystems, Inc. in the United States, other countries, or both.

Adaptec and HostRAID are trademarks of Adaptec, Inc., in the United States, other countries, or both.

Linux is a trademark of Linus Torvalds in the United States, other countries, or both.

Red Hat, the Red Hat "Shadow Man" logo, and all Red Hat-based trademarks and logos are trademarks or registered trademarks of Red Hat, Inc., in the United States and other countries.

Other company, product, or service names may be trademarks or service marks of others.

Important notes

Processor speeds indicate the internal clock speed of the microprocessor; other factors also affect application performance.

CD drive speeds list the variable read rate. Actual speeds vary and are often less than the maximum possible.

When referring to processor storage, real and virtual storage, or channel volume, KB stands for approximately 1000 bytes, MB stands for approximately 1 000 000 bytes, and GB stands for approximately 1 000 000 000 bytes.

When referring to hard disk drive capacity or communications volume, MB stands for 1 000 000 bytes, and GB stands for 1 000 000 000 bytes. Total user-accessible capacity may vary depending on operating environments.

Maximum internal hard disk drive capacities assume the replacement of any standard hard disk drives and population of all hard disk drive bays with the largest currently supported drives available from IBM.

Maximum memory may require replacement of the standard memory with an optional memory module.

IBM makes no representation or warranties regarding non-IBM products and services that are ServerProven[®], including but not limited to the implied warranties of merchantability and fitness for a particular purpose. These products are offered and warranted solely by third parties.

IBM makes no representations or warranties with respect to non-IBM products. Support (if any) for the non-IBM products is provided by the third party, not IBM.

Some software may differ from its retail version (if available), and may not include user manuals or all program functionality.

Product recycling and disposal

This unit must be recycled or discarded according to applicable local and national regulations. IBM encourages owners of information technology (IT) equipment to responsibly recycle their equipment when it is no longer needed. IBM offers a variety of product return programs and services in several countries to assist equipment owners in recycling their IT products. Information on IBM product recycling offerings can be found on IBM's Internet site at <http://www.ibm.com/ibm/environment/products/prp.shtml>.

Esta unidad debe reciclarse o desecharse de acuerdo con lo establecido en la normativa nacional o local aplicable. IBM recomienda a los propietarios de equipos de tecnología de la información (TI) que reciclen responsablemente sus equipos cuando éstos ya no les sean útiles. IBM dispone de una serie de programas y servicios de devolución de productos en varios países, a fin de ayudar a los propietarios de equipos a reciclar sus productos de TI. Se puede encontrar información sobre las ofertas de reciclado de productos de IBM en el sitio web de IBM <http://www.ibm.com/ibm/environment/products/prp.shtml>.

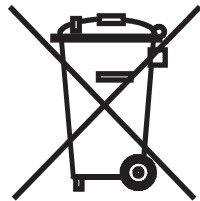

Notice: This mark applies only to countries within the European Union (EU) and Norway.

This appliance is labeled in accordance with European Directive 2002/96/EC concerning waste electrical and electronic equipment (WEEE). The Directive determines the framework for the return and recycling of used appliances as applicable throughout the European Union. This label is applied to various products to indicate that the product is not to be thrown away, but rather reclaimed upon end of life per this Directive.

注意: このマークは EU 諸国およびノルウェーにおいてのみ適用されます。

この機器には、EU 諸国に対する廃電気電子機器指令 2002/96/EC(WEEE) のラベルが貼られています。この指令は、EU 諸国に適用する使用済み機器の回収とリサイクルの骨子を定めています。このラベルは、使用済みになった時に指令に従って適正な処理をする必要があることを知らせるために種々の製品に貼られています。

Remarque : Cette marque s'applique uniquement aux pays de l'Union Européenne et à la Norvège.

L'étiquette du système respecte la Directive européenne 2002/96/EC en matière de Déchets des Equipements Electriques et Electroniques (DEEE), qui détermine les dispositions de retour et de recyclage applicables aux systèmes utilisés à travers l'Union européenne. Conformément à la directive, ladite étiquette précise que le produit sur lequel elle est apposée ne doit pas être jeté mais être récupéré en fin de vie.

In accordance with the European WEEE Directive, electrical and electronic equipment (EEE) is to be collected separately and to be reused, recycled, or recovered at end of life. Users of EEE with the WEEE marking per Annex IV of the WEEE Directive, as shown above, must not dispose of end of life EEE as unsorted municipal waste, but use the collection framework available to customers for the return, recycling, and recovery of WEEE. Customer participation is important to minimize any potential effects of EEE on the environment and human health due to the potential presence of hazardous substances in EEE. For proper collection and treatment, contact your local IBM representative.

Index

A

- Active
 - Memory 5, 33
 - PCI-X 5, 26
- Active Memory 5, 33
- adapter
 - hot-plug 26
 - installing 26
 - ServeRAID-8i 27
 - PCI 26
 - PCI-X 26
 - ServeRAID-8i 27
- adding
 - memory card 35
- administrator password 63
- attention notices 2
- Automatic BIOS recovery 7
- availability 7

B

- baseboard management controller utility programs 77
- bays 4

C

- cable
 - external cabling 48
 - routing 48
- cabling
 - multi-node configurations 49
 - XpandOnDemand cable kits 49
- cabling the server 48
- cache 4
- caution statements 2
- command-line interface
 - commands
 - identify 78
 - power 78
 - sel 78
 - sysinfo 78
- configuration
 - baseboard management controller utility programs 57
 - boot menu program 57
 - Gigabit Ethernet controller 57
 - PXE Boot Agent Utility program 57
 - SAS/SATA configuration utility program 57
 - SAS/SCSI device 49
 - Scalable Systems Web Interface 81
 - ServeRAID Manager 57
 - ServerGuide Setup and Installation CD 57
 - viewing 81
 - with ServerGuide 64
- Configuration/Setup Utility program 57, 58
- connector
 - electrostatic-discharge 10

- connector (*continued*)
 - Gigabit Ethernet 12
 - IXA RS485 12
 - keyboard 11
 - mouse 11
 - power-supply 12
 - SP Ethernet 10/100 11
 - SP serial 11
 - system serial 11
 - USB rear 11
 - USB, front 9
 - video 11
- connectors and jumper
 - I/O board 16
- cooling 6

D

- danger statements 2
- device drivers 8
- dimensions 4
- drives 4
- DVD-eject button 10
- DVD-ROM
 - activity LED 10
 - eject button 10

E

- electrical input 4
- electrostatic-discharge connector 10
- Enterprise X-Architecture technology 5
- environment 4
- error LED
 - I/O board 12
 - memory 17, 33
 - memory card 17, 33
 - microprocessor board 18
 - microprocessor 18
 - Remote Supervisor Adapter II SlimLine 11
 - system 10
 - VRM 18
- Ethernet 6
 - activity LED 12
 - configuring 57
 - connector 11
 - Gigabit activity LED 12
 - Gigabit configuring 57
 - Gigabit connector 12
 - Gigabit controller 6
 - Gigabit link LED 12
 - SP 10/100 link LED 11
 - SP activity LED 11
- expansion bays 4
- expansion slots 4
- external cabling 48

F

- fans 6
- features 3
 - ServerGuide 64
- filler panel, hard disk drive bay 30
- firmware code, updating 77
- front USB connector 9

G

- Gigabit Ethernet
 - activity LED 12
 - connector 12
 - link LED 12

H

- handling static-sensitive devices 23
- hard disk drive
 - activity LED 9, 10
 - filler panel 30
 - filler panel illustration 30
 - illustration 30
 - status LED 9
- hard disk drive activity LED 10
- heat output 4
- hot-add, memory 40
- hot-replace
 - memory card 35
- hot-swap
 - memory modules 38
- hot-swap and hot-plug devices
 - adapter 26
 - hard disk drive 30
 - memory modules 32
- humidity 4

I

- I/O board
 - error LED 12
 - illustration 16
- IBM Director 5, 8, 87
- illustration
 - I/O board connectors and jumpers 16
 - memory card connectors and LEDs 17
 - microprocessor-board connectors and LEDs 18
 - PCI-X board connectors 19
 - server components 15
- important notices 2
- information LED 9
- installation
 - completing 47
 - guidelines 21
- installing
 - hard disk drive 30
 - hot-swap hard disk drive 30
 - memory 36
 - memory modules 36
 - microprocessor 42

- installing (*continued*)
 - OSA SMBridge management utility program 76
 - power supply 24
- installing ServeRAID-8i 27
- integrated
 - baseboard management controller utility programs 77
 - network support 6
- integrated functions 4

J

- jumpers
 - boot recovery 16
 - power-on password override 16, 62
 - Wake on LAN 16

K

- keyboard connector 11

L

- LED
 - DVD-ROM activity 10
 - error
 - memory 17, 33
 - memory card 17, 33
 - microprocessor 18
 - microprocessor board 18
 - VRM 18
 - Gigabit Ethernet 1 activity 12
 - Gigabit Ethernet 1 link 12
 - Gigabit Ethernet 2 activity 12
 - Gigabit Ethernet 2 link 12
 - hard disk drive activity 9, 10
 - hard disk drive status 9
 - I/O board error 12
 - locator 10
 - memory hot-swap enabled 33
 - memory port power 33
 - memory-card, illustration 17
 - power-on 10
 - Remote Supervisor Adapter II SlimLine error 11
 - SAS activity 10
 - SP Ethernet 10/100 activity 11
 - SP Ethernet 10/100 link 11
 - system-error 10
- light path diagnostics 6
- local area network (LAN) 6

M

- management, system 5
- memory 4, 5
 - active 33
 - module 32
 - port power LED 33
- memory card
 - adding 35

- memory card (*continued*)
 - hot-replace 35
- memory hot-swap enabled LED 33
- memory mirroring 34
- Memory ProteXion 5, 34
- memory-card connector and LED illustration 17
- microprocessor 4, 6
 - installation 42
- microprocessor-board illustration 18
- mouse connector 11
- multi-node configurations
 - cabling 49
 - creating scalable partitions 81

N

- noise emissions 4
- NOS installation
 - with ServerGuide 65
 - without ServerGuide 65
- notes, important 90
- notices and statements 2

O

- online publications 2
- operator information panel 9
- OSA SMBridge management utility program
 - enabling and configuring 68
 - installing 76

P

- password
 - administrator 63
 - power-on 62
 - power-on override jumper 62
- passwords 62
- PCI-X board connectors illustration 19
- PCI-X board LEDs 19
- PCI-X, active 5
- power requirement 4
- power supply 4
 - connector 12
 - hot-swap 24
 - installing 24
 - LEDs 26
- power-control
 - button 9
 - button shield 9
- power-on
 - LED 10
 - password 62
- publications 1
- PXE Boot Agent Utility program 57
 - using 66

R

- rack, installing your server in 47
- RAS features 7
- release latch 10
- reliability 7
- Remote Supervisor Adapter II SlimLine
 - error LED 11
 - functions disabled 59
- Remote Supervisor Adapter II Web User Interface 81
- removing
 - the bezel 23
 - the cover 23

S

- SAS
 - activity LED 10
 - SAS/SATA configuration utility program 79
- SAS/SATA configuration utility program 79
- Scalable Systems Web Interface 81
- serial connector 11
- serial over LAN
 - commands
 - connect 78
 - identify 78
 - power 78
 - reboot 79
 - sel get 79
 - sol 79
 - sysinfo 79
- server power features 12
- ServeRAID 6
- ServerGuide
 - features 64
 - NOS installation 65
 - Setup and Installation CD 5, 57
 - using 63
- serviceability 7
- setup
 - with ServerGuide 64
- size 4
- slots 4
- SMP 6
- SMP Expansion cables 49
- SMP Expansion Port connectors 12
- SMP Expansion Port link LEDs 12
- SP Ethernet 10/100 activity LED 11
- SP Ethernet 10/100 link LED 11
- specifications 3
- statements and notices 2
- symmetric multiprocessing 6
- system reliability guidelines 22
- system-error LED 10
- systems management 5, 6, 8

T

- table
 - features and specifications 3
 - I/O board jumpers 16

table *(continued)*

memory

cost-sensitive configuration 32

memory-mirroring configuration 33

performance configuration 32

temperature 4

trademarks 89

turning off the server 13

turning on the server 13

U

UpdateXpress 8

updating the firmware code 77

USB connectors 9

utility

baseboard management controller utility

programs 77

Configuration/Setup program, using 58

OSA SMBridge management utility program 78

PXE boot agent utility program 66

SAS/SATA configuration utility program 79

Scalable Systems Web Interface 81

ServerRAID manager 79

the boot menu program 65

V

video connector 11

W

Web site

ServerGuide 63

weight 4

working inside the server with the power on 22

X

X-Architecture technology 5

XpandOnDemand cable kits 49



Part Number: 31R1871

Printed in USA

(1P) P/N: 31R1871

