



@server

xSeries 225

Type 8647

User's Guide



IBM xSeries 225
Type 8647



User's Guide

Note:

Before using this information and the product it supports, read the general information in Appendix B, "Warranty information" on page 25, and Appendix C, "Notices" on page 37.

First Edition (November 2002)

© Copyright International Business Machines Corporation 2002. All rights reserved.

US Government Users Restricted Rights – Use, duplication or disclosure restricted by GSA ADP Schedule Contract with IBM Corp.

Contents

Safety	v
Chapter 1. Introducing the IBM xSeries 225 Type 8647 server.	1
Notices and statements used in this book	1
Related publications	2
Features and specifications	3
What your server offers	4
Reliability, availability, and serviceability features	5
Updating device drivers and firmware	6
IBM Director	6
Controls and indicators	8
Server power features	10
Turning on the server	10
Turning off the server	11
Chapter 2. Configuring your server	13
Using the Configuration/Setup Utility program	13
Starting the Configuration/Setup Utility program	13
Configuration/Setup Utility menu choices	14
Passwords	16
Using the ServerGuide Setup and Installation CD	17
ServerGuide features	17
Setup and configuration overview	18
System Partition	19
Typical operating system installation	19
Setting up or updating multiple servers	20
Installing your operating system without ServerGuide	20
Using ServeRAID Manager	20
Using the LSI Logic Configuration Utility program	21
Starting the LSI Logic Configuration Utility program	21
Formatting a SCSI hard disk drive	22
Configuring the Gigabit Ethernet controller	22
Appendix A. Getting help and technical assistance	23
Before you call	23
Using the documentation	23
Getting help and information from the World Wide Web	23
Software service and support	24
Hardware service and support	24
Appendix B. Warranty information	25
Warranty period	25
Problem determination	25
Warranty service and support	26
International Warranty Service	26
Purchasing additional services	27
IBM Statement of Limited Warranty Z125-4753-06 8/2000	28
Part 1 - General Terms	28
Part 2 - Country-unique Terms	30
Appendix C. Notices	37
Edition notice	37
Trademarks	38

Important notes	38
Electronic emission notices	39
Federal Communications Commission (FCC) statement	39
Industry Canada Class A emission compliance statement	39
Australia and New Zealand Class A statement	40
United Kingdom telecommunications safety requirement.	40
European Union EMC Directive conformance statement.	40
Taiwan electrical emission statement	40
Japanese Voluntary Control Council for Interference (VCCI) statement	40
Power cords	41
Index	43

Safety

Before installing this product, read the Safety Information.

قبل تركيب هذا المنتج، يجب قراءة الملاحظات الأمنية

Antes de instalar este produto, leia as Informações de Segurança.

在安装本产品之前，请仔细阅读 **Safety Information** (安全信息)。

安裝本產品之前，請先閱讀「安全資訊」。

Prije instalacije ovog produkta obavezno pročitajte Sigurnosne Upute.

Před instalací tohoto produktu si přečtěte příručku bezpečnostních instrukcí.

Læs sikkerhedsforskrifterne, før du installerer dette produkt.

Lees voordat u dit product installeert eerst de veiligheidsvoorschriften.

Ennen kuin asennat tämän tuotteen, lue turvaohjeet kohdasta Safety Information.

Avant d'installer ce produit, lisez les consignes de sécurité.

Vor der Installation dieses Produkts die Sicherheitshinweise lesen.

Πριν εγκαταστήσετε το προϊόν αυτό, διαβάστε τις πληροφορίες ασφάλειας (safety information).

לפני שתתקינו מוצר זה, קראו את הוראות הבטיחות.

A termék telepítése előtt olvassa el a Biztonsági előírásokat!

Prima di installare questo prodotto, leggere le Informazioni sulla Sicurezza.

製品の設置の前に、安全情報をお読みください。

본 제품을 설치하기 전에 안전 정보를 읽으십시오.

Пред да се инсталира овој продукт, прочитајте информацијата за безбедност.

Les sikkerhetsinformasjonen (Safety Information) før du installerer dette produktet.

Przed zainstalowaniem tego produktu, należy zapoznać się z książką "Informacje dotyczące bezpieczeństwa" (Safety Information).

Antes de instalar este produto, leia as Informações sobre Segurança.

Перед установкой продукта прочтите инструкции по технике безопасности.

Pred inštaláciou tohto zariadenia si pečítajte Bezpečnostné predpisy.

Pred namestitvijo tega proizvoda preberite Varnostne informacije.

Antes de instalar este producto lea la información de seguridad.

Läs säkerhetsinformationen innan du installerar den här produkten.

Statement 1



Danger

Electrical current from power, telephone, and communication cables is hazardous.

To avoid a shock hazard:

- Do not connect or disconnect any cables or perform installation, maintenance, or reconfiguration of this product during an electrical storm.
- Connect all power cords to a properly wired and grounded electrical outlet.
- Connect to properly wired outlets any equipment that will be attached to this product.
- When possible, use one hand only to connect or disconnect signal cables.
- Never turn on any equipment when there is evidence of fire, water, or structural damage.
- Disconnect the attached power cords, telecommunications systems, networks, and modems before you open the device covers, unless instructed otherwise in the installation and configuration procedures.
- Connect and disconnect cables as described in the following table when installing, moving, or opening covers on this product or attached devices.

To connect:

1. Turn everything OFF.
2. First, attach all cables to devices.
3. Attach signal cables to connectors.
4. Attach power cords to outlet.
5. Turn device ON.

To disconnect:

1. Turn everything OFF.
2. First, remove power cords from outlet.
3. Remove signal cables from connectors.
4. Remove all cables from devices.

Statement 2



CAUTION:

When replacing the lithium battery, use only IBM Part Number 33F8354 or an equivalent type battery recommended by the manufacturer. If your system has a module containing a lithium battery, replace it only with the same module type made by the same manufacturer. The battery contains lithium and can explode if not properly used, handled, or disposed of.

Do not:

- Throw or immerse into water.
- Heat to more than 100°C (212°F)
- Repair or disassemble

Dispose of the battery as required by local ordinances or regulations.

Statement 3



CAUTION:

When laser products (such as CD-ROMs, DVD drives, fiber optic devices, or transmitters) are installed, note the following:

- Do not remove the covers. Removing the covers of the laser product could result in exposure to hazardous laser radiation. There are no serviceable parts inside the device.
- Use of controls or adjustments or performance of procedures other than those specified herein might result in hazardous radiation exposure.



Danger

Some laser products contain an embedded Class 3A or Class 3B laser diode. Note the following. Laser radiation when open. Do not stare into the beam, do not view directly with optical instruments, and avoid direct exposure to the beam.

Statement 4

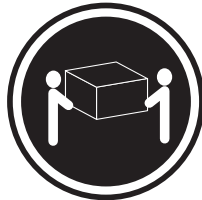

≥18 kg (39.7 lb)



≥32 kg (70.5 lb)



≥55 kg (121.2 lb)

CAUTION:

Use safe practices when lifting.

Statement 5



CAUTION:

The power-control button on the device and the power switch on the power supply do not turn off the electrical current supplied to the device. The device also might have more than one power cord. To remove all electrical current from the device, ensure that all power cords are disconnected from the power source.

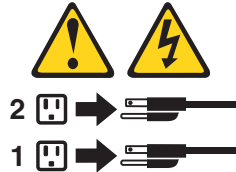

Statement 8



CAUTION:

Never remove the cover on a power supply or any part that has the following label attached.



Hazardous voltage, current, and energy levels are present inside any component that has this label attached. There are no serviceable parts inside these components. If you suspect a problem with one of these parts, contact a service technician.

Statement 12



CAUTION:

The following label indicates a hot surface nearby.



Statement 13



DANGER:
Overloading a branch circuit is potentially a fire hazard and a shock hazard under certain conditions. To avoid these hazards, ensure that your system electrical requirements do not exceed the branch circuit protection requirements. Refer to the information that is provided with your IBM device for electrical specifications.

Statement 15



CAUTION:
Make sure that the rack is secured properly to avoid tipping when the server unit is extended.

Statement 23



CAUTION:
Do not place any object weighing more than 50 kg (110 lb) on top of rack-mounted devices.



>50 kg (110 lb)

Declaración 23



PRECAUCIÓN:

No coloque ningún objeto que pese más de 50 kg (110 libras) encima de los dispositivos montados en bastidor.



>50 kg (110 libras)

Hinweis 23



ACHTUNG:

Keine Gegenstände, die mehr als 50 kg wiegen, auf Rack-Einheiten ablegen.



>50 kg

Notice n° 23



ATTENTION:

Ne posez pas d'objet dont le poids dépasse 50 kg sur les unités montées en armoire.



>50 kg

Varningsmeddelande 23



VARNING:

Placera inte något föremål som väger mer än 50 kg ovanpå rackmonterade enheter.



>50 kg

Merknad 23



ADVARSEL:

Ikke sett gjenstander som veier mer enn 50 kg oppå enheter som er montert i et kabinett.



>50 kg

Avviso 23



ATTENZIONE:

Non poggiare oggetti che pesano più di 50 kg sulla parte superiore delle unità montate in rack.



>50 kg

Turvaohje 23



Varoitus:

Telineeseen asennettujen laitteiden päälle ei saa asettaa yli 50 kilon painoista esinettä.



>50 kg

Voorschrift 23



WAARSCHUWING:

Plaats geen objecten die meer dan 50 kg wegen op apparaten die in het rek zijn gemonteerd.



>50 kg

Forskrift 23



Pas på!:

Anbring ikke genstande, der vejer mere end 50 kg, oven på enheder, der er monteret i rack.



>50 kg

Instrução 23



CUIDADO:

Não coloque nenhum objeto com peso superior a 50 kg (110 lbs.) sobre dispositivos montados em rack.



>50 kg (110 lbs)

عبارة ٢٣



تنبيه :

لا تضع أي عنصر يزن أكثر من ٥٠ كيلوجرام (١١٠ رطل) أعلى سطح الأجهزة.



أكبر من ٥٠ كيلوجرام (١١٠ رطل)

• Izjava br. 23



OPREZ:

Ne postavljajte predmete teže od 50 kg (110 funti) na ormar u koji su ugrađeni uređaji.



> 50 kg (110 lbs)

Δήλωση 23



ΠΡΟΣΟΧΗ:

Μην τοποθετείτε οποιοδήποτε αντικείμενο με βάρος μεγαλύτερο από 50 kg επάνω σε συσκευές που έχουν προσαρμοσθεί σε ικρίωμα (rack).



> 50 kg

הודעה 23



זהירות:

אל תניחו שום חפץ שמשקלו יותר מ-50 ק"ג על גבי התקנים המורכבים על חסדי מרשימים.



50 ק"ג

- 23. ismertető



FIGYELEM:

Keretszerelésű eszközök tetejére ne helyezzen olyan tárgyat, melynek súlya több, mint 50 kg (110 lbs.).



> 50 kg (110 lbs)

・記述 23

注意

ラック・モデルのサーバーの上に 50 Kg 以上の物を置かないでください。



> 50 Kg

경고문 23



주의:

서랍형 모델의 장치 상단에 50 kg(110 lbs.)이 넘는 물체를 올려 놓지 마십시오.



> 50 kg (110 lbs)

Instrukcja 23



ZAGROŻENIE:

Nie należy umieszczać przedmiotów cięższych niż 50 kg (110 funtów.)



> 50 kg (110 funtów)

· Положение 23



ОСТОРОЖНО:

Не ставьте предметы весом более 50 кг на верхнюю крышку устройств, смонтированных на выдвижных полках.



> 50 кг

声明 23



警告:

机柜安装的设备上面不能放置重于 50kg (110 磅) 的物品。



> 50 kg (110 磅)

· Príkaz 23



VÝSTRAHA:

Neumiestňujte žiadny predmet vážiaci viac ako 50 kg (110 lbs.) na vrch zariadenia montovaného do stojana.



> 50 kg (110 lbs)

· Navedba 23



SVARILO:

Ne postavljajte nobenega predmeta, ki je težji od 50 kg, na vrh naprav, montiranih v stojala.



> 50 kg (110 lbs)

聲明 23



注意：

請勿將任何重量超過 50 公斤 (110 磅) 的物品置於已安裝機架的裝置上方。



> 50 公斤 (110 磅)

Instrukce 23



POZOR:

Neumíst'ujte nic s hmotností vyšší než 50 kg navrch zařízení namontovaných do stojanu.

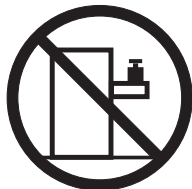

>50 kg (110 lbs)

▪ Инструкција 23



ПРЕДУПРЕДУВАЊЕ:

Не поставувајте предмети потешки од 50 кг. (110 lbs.) над уредите кои се монтирани во ормари.



>50 kg (110 lbs)

Instrução 23



CUIDADO:

Não coloque nenhum objeto com peso superior a 50 kg (110 lbs.) sobre dispositivos montados em rack.



>50 kg (110 lbs)

Chapter 1. Introducing the IBM xSeries 225 Type 8647 server

The IBM® @server xSeries 225 Type 8647 server is a high-performance server based on IBM X-Architecture™ technologies. It can be upgraded to a symmetric multiprocessing (SMP) server through a microprocessor upgrade. It is ideally suited for networking environments that require superior microprocessor performance, efficient memory management, flexibility, and large amounts of reliable data storage.

Your xSeries 225 server contains several IBM X-Architecture technologies, which provide increased performance, reliability, and availability. The X-Architecture technologies provided in your server include the recent advancements in X-Architecture features. For more information about the X-Architecture features, see “What your server offers” on page 4 and “Reliability, availability, and serviceability features” on page 5. You can obtain more information about the IBM X-Architecture technologies and features at <http://www.ibm.com/pc/us/eserver/xseries/xarchitecture/> on the World Wide Web.

Performance, ease of use, reliability, and expansion capabilities were key considerations during the design of your server. These design features make it possible for you to customize the system hardware to meet your needs today, while providing flexible expansion capabilities for the future.

If you have access to the Internet, you can obtain up-to-date information about your server model and other IBM server products at <http://www.ibm.com/pc/us/eserver/xseries/> on the World Wide Web.

Your server serial number and model number are on labels on the bottom of the server and on the front of the server near the bottom of the bezel behind the door. You will need these numbers when you register your server with IBM. The information label containing the serial number, machine type, model number, and agency marks for your server is on the bottom of the server.

The latest version of this publication is available from the IBM Web site. Go to <http://www.ibm.com> and click **Support & downloads**. In the **Technical support** keyword search field, type 8647 and click **Go**. A list of publications for your server is displayed.

Note: The illustrations in this document might differ slightly from your hardware.

Notices and statements used in this book

The caution and danger statements that appear in this book are also in the multilingual *Safety Information* book, which is on the IBM xSeries™ *Documentation* CD. Each statement is numbered for reference to the corresponding statement in the *Safety Information* book.

The following notices and statements are used in the documentation:

- **Notes:** These notices provide important tips, guidance, or advice.
- **Important:** These notices provide information or advice that might help you avoid inconvenient or problem situations.
- **Attention:** These notices indicate potential damage to programs, devices, or data. An attention notice is placed just before the instruction or situation in which damage could occur.

- **Caution:** These statements indicate situations that can be potentially hazardous to you. A caution statement is placed just before the description of a potentially hazardous procedure step or situation.
- **Danger:** These statements indicate situations that can be potentially lethal or extremely hazardous to you. A danger statement is placed just before the description of a potentially lethal or extremely hazardous procedure step or situation.

Related publications

This *User's Guide* provides general information about your server, including information about features, how to configure the server, how to use the *ServerGuide™ Setup and Installation* CD, and how to get help. In addition to this *User's Guide*, the following documentation comes with your server:

- *Installation Guide*
This printed publication contains setup and installation instructions.
- *Safety Information book*
This multilingual publication is provided in PDF on the IBM *xSeries Documentation* CD. It contains translated versions of the caution and danger statements that appear in the documentation for your server. Each caution and danger statement has an assigned number, which you can use to locate the corresponding statement in your native language.
- *Hardware Maintenance Manual and Troubleshooting Guide*
This publication is provided in PDF on the IBM *xSeries Documentation* CD. It contains information to help you solve the problem yourself or to provide helpful information to a service technician.
- *Option Installation Guide*
This publication is provided in PDF on the IBM *xSeries Documentation* CD. It contains instructions to install, remove, and connect optional devices supported by your server.

The latest versions of this *User's Guide* and other publications for your server are available from the IBM Web site. Go to <http://www.ibm.com/> and click **Support & downloads**. In the **Technical support** keyword search field, type 8647 and click **Go**. A list of publications for your server is displayed.

Depending on your server model, additional publications might be included on the IBM *xSeries Documentation* CD.

Features and specifications

The following table provides a summary of the features and specifications of your server. Depending on your server model, some features might not be available, or some specifications might not apply.

You can use the Configuration/Setup Utility program in your server to determine the specific type of microprocessor that is on the system board.

Table 1. Features and specifications

<p>Microprocessor:</p> <ul style="list-style-type: none"> • Intel Xeon™ Processor • 512 KB Level-2 cache • 400 MHz or 533 MHz front-side bus (FSB) • Support for up to two microprocessors <p>Memory:</p> <ul style="list-style-type: none"> • Minimum: 256 MB • Maximum: 8 GB • Type: PC2100, double-data-rate (DDR) • Connectors: four dual inline memory module (DIMM) connectors, two-way interleaved <p>Drives standard:</p> <ul style="list-style-type: none"> • Diskette: 1.44 MB (two mode) • CD-ROM: IDE <p>Expansion bays:</p> <ul style="list-style-type: none"> • Six open hot-swap, slim-high, 3.5-inch drive bays (some models) • Four slim-high, 3.5-inch drive bays with one hard disk drive installed (some models) • Two 5.25-inch bays (CD-ROM drive installed in one bay) • One 3.5-inch removable-media drive bay (diskette drive installed) <p>PCI expansion slots:</p> <ul style="list-style-type: none"> • Four PCI-X 100 MHz/64-bit • One PCI 33 MHz/32-bit <p>Cooling:</p> <p>Three speed-controlled fans</p> <p>Upgradeable microcode:</p> <p>BIOS upgrades (when available) can update EEPROMs on the system board</p>	<p>Integrated functions:</p> <ul style="list-style-type: none"> • Support for IBM Remote Supervisor Adapter • Broadcom 5703 10/100/1000 Ethernet controller on the system board with RJ-45 Ethernet port • Two serial ports • One parallel port • Integrated SCSI controller with RAID capabilities and two Ultra320 SCSI ports (one internal, one optional external) • Four Universal Serial Bus (USB) v2.0 ports (two on front and two on rear of enclosure) • Keyboard port • Mouse port • Audio ports (rear) <ul style="list-style-type: none"> – Line out – Mic – Line in • ATA-100 dual-channel IDE controller • ATI Rage XL video (mini-PCI) <ul style="list-style-type: none"> – Compatible with SVGA and VGA – 8 MB video memory <p>Failure LEDs:</p> <ul style="list-style-type: none"> • Fans • Memory • Microprocessors <p>Power supplies:</p> <ul style="list-style-type: none"> • Hot-swap (some models) <ul style="list-style-type: none"> Standard: Two 350 watt output (115-230 V ac) for redundancy • Non-hot-swap (some models) <ul style="list-style-type: none"> Standard: One 425 watt output (115-230 V ac) 	<p>Electrical input:</p> <ul style="list-style-type: none"> • Sine-wave input (50 or 60 Hz) required • Input voltage and frequency ranges automatically selected • Input voltage low range: <ul style="list-style-type: none"> – Minimum: 100 V ac – Maximum: 127 V ac • Input voltage high range: <ul style="list-style-type: none"> – Minimum: 200 V ac – Maximum: 240 V ac • Input kilovolt-amperes (kVA) approximately: <ul style="list-style-type: none"> – Minimum: 0.15 kVA (all models) – Maximum: 0.80 kVA with standard power supply, 0.62 kVA with optional redundant hot-swap power supplies <p>Heat output:</p> <p>Approximate heat output in British thermal units (Btu) per hour</p> <ul style="list-style-type: none"> • Minimum configuration: 341 Btu/hour (100 watts) • Maximum configuration: 2455 Btu/hour (720 watts) with standard power supply, 1910 Btu/hour (560 watts) with optional redundant hot-swap power supplies <p>Environment:</p> <ul style="list-style-type: none"> • Air temperature: <ul style="list-style-type: none"> – Server on: 10° to 35°C (50° to 95°F) Altitude: 0 to 2134 m (7000 ft) – Server off: -40° to +60°C (-40° to 140°F) Maximum altitude: 2133 m (7000 ft) • Humidity (operating and storage): 8% to 80% <p>Acoustical noise emissions:</p> <ul style="list-style-type: none"> • Sound power, idle: 5.3 bel maximum • Sound power, operating: 5.6 bel maximum <p>Size:</p> <ul style="list-style-type: none"> • Height: 440 mm (18.4 in.) • Depth: 660 mm (26 in.) • Width: 217 mm (8.6 in.) • Weight: 20 kg (44 lb) to 25.8 kg (57 lb) depending upon configuration
---	--	--

What your server offers

Your server takes advantage of advancements in symmetric multiprocessing (SMP), data storage, disk-array technologies, and memory management. Your server includes:

- **IBM X-Architecture design**

IBM X-Architecture technology combines proven, innovative IBM designs to make your Intel-processor-based server powerful, scalable, and reliable. X-Architecture design includes Chipkill™ memory, hot-swappable hard disk drives, and Predictive Failure Analysis® capability.

- **Impressive performance using SMP**

Your server supports up to two Intel Xeon microprocessors. It comes with at least one microprocessor installed; if it comes with only one microprocessor, you can install an additional microprocessor to enhance performance and provide SMP capability.

- **Large data-storage and hot-swap capabilities**

Some server models support up to six 25.4-mm (1-inch) slim-high, 3.5-inch hot-swap hard disk drives in the hot-swap bays. With the hot-swap feature, you can add, remove, or replace hard disk drives without turning off the server.

- **Redundant power capabilities**

Some models of the server come with two 350-watt hot-swap power supplies, which provide redundant power for many server configurations. If the average load on your server is less than 350 watts and a problem occurs with one of the power supplies, the other power supply can handle the load.

- **Large system memory**

Your server supports up to 8 GB of system memory. The memory controller provides error correcting code (ECC) support for up to four industry-standard, 133 MHz, 2.5 V, 184-pin, double-data-rate (DDR), PC2100 registered, synchronous dynamic random access memory (SDRAM) dual inline memory modules (DIMMs). The memory controller provides Chipkill memory protection if all DIMMs are type x4 and are 256 MB or larger. Chipkill memory protection is a technology that protects the server from a single chip failure on a DIMM.

- **System-management capabilities**

Your server supports an optional IBM Remote Supervisor Adapter. By using the optional IBM Remote Supervisor Adapter with the system-management software that comes with your server, you can manage the functions of the server locally and remotely giving you a World Wide Web interface to the system-management functions.

See the documentation that comes with your system-management software for more information. To order an optional Remote Supervisor Adapter, contact your IBM marketing representative or authorized reseller.

- **Integrated network environment support**

Your server comes with an integrated Broadcom Gigabit Ethernet controller on the system board. This Ethernet controller has an interface for connecting to a 10-Mbps, 100-Mbps, or 1-Gbps network. The server automatically selects between 10BASE-T and 100/1000BASE-TX environments. The controller provides full-duplex (FDX) capability, which enables simultaneous transmission and reception of data on an Ethernet local area network (LAN). This controller supports Wake on LAN® technology.

- **Redundant connection**

The addition of an optional network interface card (NIC) provides a failover capability to a redundant Ethernet connection. If a problem occurs with the

primary Ethernet connection, all Ethernet traffic associated with the primary connection is automatically switched to the redundant NIC. If the appropriate device drivers are installed, this switching occurs without data loss and without user intervention.

- **IBM ServerGuide Setup and Installation CD**

The *ServerGuide Setup and Installation* CD that comes with your server provides programs to help you set up your server and install the operating system. The ServerGuide program detects installed hardware options and provides the correct configuration programs and device drivers.

For more information about the *ServerGuide Setup and Installation* CD, see “Using the ServerGuide Setup and Installation CD” on page 17.

- **ServeRAID support**

Your server supports IBM ServeRAID adapters to create redundant array of independent disks (RAID) configurations.

- **IBM Director**

IBM Director is a workgroup-hardware-management tool that you can use to centrally manage xSeries servers. For more information about IBM Director, see the IBM Director *User's Guide* on the IBM *xSeries Documentation* CD.

- **Device Driver and IBM Enhanced Diagnostics CD**

Your server comes with a *Device Driver and IBM Enhanced Diagnostics* CD, which you can use to diagnose problems with the server.

Reliability, availability, and serviceability features

Three important server design features are reliability, availability, and serviceability (RAS). The RAS features help to ensure the integrity of the data that is stored on your server, the availability of the server when you need it, and the ease with which you can diagnose and repair problems.

Your server had the following RAS features:

- 1-year parts, 1-year labor limited warranty
- Advanced Configuration and Power Interface (ACPI)
- Advanced Desktop Management Interface (DMI) features
- Alert Standard Format (ASF) support providing seven standard alerts for components such as fans, voltage, and thermals
- Automatic BIOS recovery to a backup image
- Automatic error retry or recovery
- Automatic memory downsizing on error detection
- Automatic restart on non-maskable interrupt (NMI)
- Automatic Server Restart (ASR) logic supporting a system restart when the operating system becomes unresponsive
- Automatic server restart after a power failure, based on the BIOS setting
- Availability of microcode and diagnostic levels
- Boot-block recovery
- Built-in, menu-driven setup, system configuration, redundant array of independent disks (RAID) configuration, and diagnostic programs
- Built-in monitoring for fan, power, temperature, and voltage
- CD-based diagnostic programs
- Chipkill memory protection

- Cooling fans with speed-sensing capability
- Customer support center that is available 24 hours a day, 7 days a week¹
- Diagnostic support of ServeRAID adapters
- Error codes and messages
- Error correcting code (ECC) double-data-rate (DDR) synchronous dynamic random access memory (SDRAM) with serial presence detect (SPD)
- Error logging of POST failures
- Hot-swap hard disk drives
- Integrated Ethernet controller
- Support for the optional IBM Remote Supervisor Adapter
- Key-lock support for physical security
- Memory change messages posted to the error log
- Power-on self-test (POST)
- Predictive Failure Analysis (PFA) alerts
- Read-only memory (ROM) checksums
- Redundant Ethernet capabilities (requires an optional Ethernet adapter) with failover support
- Redundant hot-swap power supplies (some models)
- Standby voltage for system-management features and monitoring
- System auto-configuring from the configuration menu
- System-error LED on the front bezel and diagnostics LEDs on the system board
- Upgradeable basic input/output system (BIOS) and POST code
- Upgradeable microcode for POST, BIOS, and read-only memory (ROM) resident code, locally or over a LAN
- Vital product data (VPD); includes serial-number information and replacement part numbers, stored in nonvolatile memory, for easier remote maintenance
- Wake on LAN capability
- xSeries Server Management

Updating device drivers and firmware

The Update*Xpress* program is available for most xSeries servers and server options. It detects supported and installed device drivers and firmware in your server and installs available updates. You can download the Update*Xpress* program from the Web at no additional cost, or you can purchase it on a CD. To download the program or purchase the CD, go to the IBM Support Web site at <http://www.ibm.com/pc/ww/eserver/xseries/serverguide/xpress.html>.

IBM Director

With IBM Director, a network administrator can:

- View the hardware configuration of remote systems, in detail
- Monitor the usage and performance of critical components, such as microprocessors, disks, and memory
- Centrally manage individual or large groups of IBM and non-IBM Intel-based servers, desktop computers, workstations, and mobile computers on a variety of platforms

1. Service availability will vary by country. Response time varies; may exclude holidays.

IBM Director provides a comprehensive entry-level workgroup hardware manager. Key features include:

- Advanced self-management capabilities for maximum system availability
- Multiple operating-system platform support, including Microsoft Windows 98, Windows 2000, Windows XP Professional, Novell NetWare, IBM OS/2, SCO UnixWare, Linux, and Caldera OpenUNIX
- Support for IBM and non-IBM servers, desktop computers, workstations, and mobile computers
- Support for systems-management industry standards
- Integration into leading workgroup and enterprise systems-management environments
- Ease of use, training, and setup

IBM Director also provides an extensible platform that supports advanced server tools that are designed to reduce the total cost of managing and supporting networked systems. By deploying IBM Director, you can achieve reductions in ownership costs through:

- Reduced downtime
- Increased productivity of IT personnel and users
- Reduced service and support costs

For more information about IBM Director, see the *IBM Director* CD that comes with your server, the IBM Director publications on the CD, and the following Web pages:

Systems Management - Director Package

<http://www.ibm.com/pc/qtechinfo/MIGR-40738.html>

This Web page includes links to software downloads and publications for the latest release of IBM Director.

IBM xSeries Systems Management page

http://www.ibm.com/pc/ww/eserver/xseries/systems_management/index.html

This Web page presents an overview of IBM Systems Management and IBM Director.

IBM Universal Manageability page

<http://www.ibm.com/pc/us/pc/um/index.html>

This Web page links to an IBM portfolio of advanced management tools that help reduce costs and increase availability throughout the life cycle of a product.

Controls and indicators

The following illustration shows the controls and LEDs on the server.

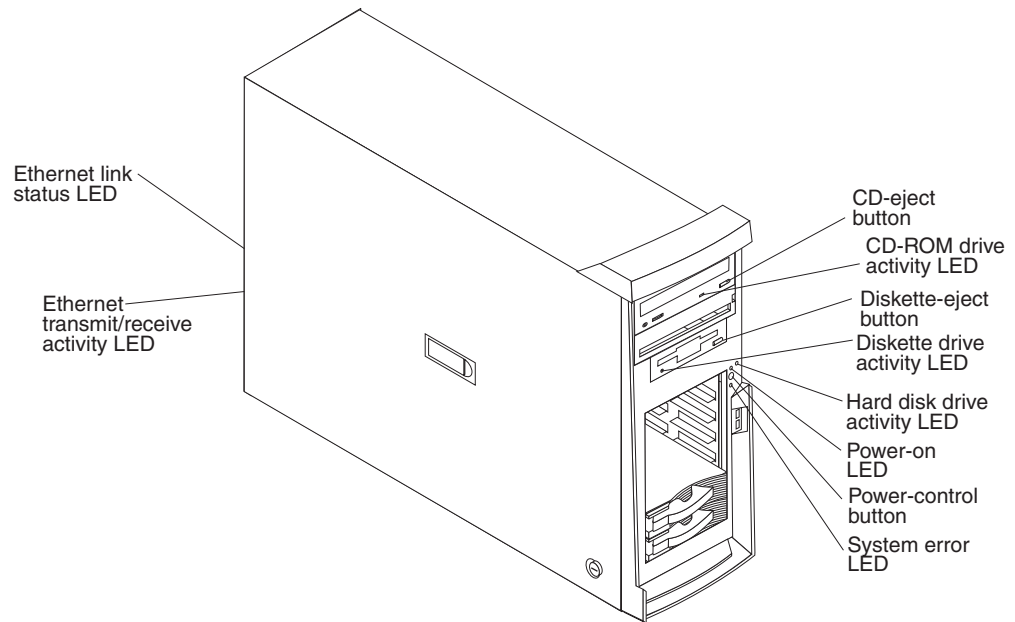

AC power LED

This LED is on each hot-swap power supply on the back of some server models. During typical operation, both the ac and dc power LEDs are on. For any other combination of LEDs, see the *Hardware Maintenance Manual and Troubleshooting Guide* on the IBM xSeries Documentation CD.

CD-eject button

Press this button to release a CD from the CD-ROM drive.

CD-ROM drive activity LED

When this LED is lit, it indicates that the CD-ROM drive is in use.

DC power LED

This LED is on each hot-swap power supply on the back of some server models. During typical operation, both the ac and dc power LEDs are on. For any other combination of LEDs, see the *Hardware Maintenance Manual and Troubleshooting Guide* on the IBM xSeries Documentation CD.

Diskette drive activity LED

When this LED is lit, it indicates that the diskette drive is in use.

Diskette-eject button

Press this button to release a diskette from the diskette drive.

Ethernet link status LED

This LED is on the Ethernet connector on the back of the server. When this LED is lit, it indicates that there is an active connection on the Ethernet port.

Ethernet transmit/receive activity LED

This LED is on the Ethernet connector on the back of the server. When this LED is lit, it indicates that there is activity between the server and the network.

Hard disk drive activity LED

When this LED is flashing, it indicates that a hard disk drive is in use.

Hot-swap hard disk drive activity LED

On some server models, each hot-swap drive has a hard disk drive activity LED. When this green LED is flashing, it indicates that the drive is in use.

Hot-swap hard disk drive status LED

On some server models, each hot-swap drive has a hard disk drive status LED. When this amber LED is lit, it indicates that the drive has failed. If an optional IBM ServeRAID™ controller is installed in the server, when the LED flashes slowly (one flash per second), the drive is being rebuilt. When the LED flashes rapidly (three flashes per second), the controller is identifying the drive.

Power-control button

Press this button to turn the server on and off manually. A power-control-button shield comes with your server. You can install this disk-shaped shield to prevent the server from being turned off accidentally.

Power-on LED

When this LED is lit and not flashing, it indicates that the server is turned on. When this LED is flashing, it indicates that the server is off and still connected to an ac power source (standby mode).

System-error LED

When this LED is lit, it indicates that a system error has occurred. An LED on the system board might also be lit to help isolate the error. Detailed troubleshooting information is in the *Hardware Maintenance Manual and Troubleshooting Guide* on the IBM xSeries Documentation CD.

Server power features

When the server is connected to an ac power source but is not turned on, the operating system does not run, and all core logic is shut down; however, the server can respond to remote requests to turn on the server. The power-on LED flashes to indicate that the server is connected to an ac power source but is not turned on (standby mode).

Turning on the server

Notes:

1. Turn on all external devices, such as the monitor, before turning on the server.
2. The power-on LED on the front of the server is lit when the server is on and while it is powering-up.
3. You can install a circular disk over the power-control button to prevent accidental manual power-off. This disk, known as the power-control button shield, comes with your server.

Approximately 20 seconds after the server is connected to ac power, the power-control button becomes active, and you can turn on the server and start the operating system by pressing the power-control button. The server can also be turned on in any of the following ways:

- If a power failure occurs while the server is turned on, the server will restart automatically when power is restored.
- If the server is connected to an ASM interconnect network that contains at least one server with an optional Remote Supervisor Adapter installed, the server can be turned on from the Remote Supervisor Adapter user interface.
- If an optional Remote Supervisor Adapter is installed in the server, the server can be turned on from the Remote Supervisor Adapter user interface.
- When you plug in your server for the first time, the Wake on LAN feature can turn on the server. If your server was previously turned on, it must be properly turned off for the Wake on LAN feature to turn on the server.

Note: When 4 GB or more of memory (physical or logical) is installed, some memory is reserved for various system resources and is unavailable to the operating system. The amount of memory that is reserved for system resources depends on the operating system, the configuration of the server, and the configured PCI options.

Turning off the server

When you turn off the server and leave it connected to ac power, the server can respond to remote requests to turn on the server. To remove all power from the server, you must disconnect it from the power source.

Some operating systems require an orderly shutdown before you turn off the server. See your operating-system documentation for information about shutting down the operating system.

Statement 5



CAUTION:

The power-control button on the device and the power switch on the power supply do not turn off the electrical current supplied to the device. The device also might have more than one power cord. To remove all electrical current from the device, ensure that all power cords are disconnected from the power source.

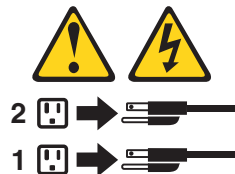

Note: After turning off the server, wait at least 5 seconds before you press the power-control button to turn on the server again.

The server can be turned off in any of the following ways:

- You can turn off the server from the operating system, if your operating system supports this feature. After an orderly shutdown of the operating system, the server will be turned off automatically.
- You can press the power-control button to start an orderly shutdown of the operating system and turn off the server, if your operating system supports this feature.
- If the operating system stops functioning, you can press and hold the power-control button for more than 4 seconds to turn off the server.
- If the server is connected to an ASM interconnect network that contains at least one system with an optional Remote Supervisor Adapter installed, the server can be turned off from the Remote Supervisor Adapter user interface.
- If an optional Remote Supervisor Adapter is installed in the server, the server can be turned off from the Remote Supervisor Adapter user interface.
- The server can turn itself off as an automatic response to a critical system failure.

Chapter 2. Configuring your server

The following configuration programs are provided with your server:

- **Configuration/Setup Utility**

This is part of the basic input/output system (BIOS) code in your server. Use it to configure serial port assignments, change interrupt request (IRQ) settings, change the startup-device sequence, set the date and time, and set passwords. For information about using this utility program, see “Using the Configuration/Setup Utility program”.

- **IBM ServerGuide Setup and Installation CD**

This provides software-setup tools and installation tools that are designed for your server. Use this CD during the installation of your server to configure basic hardware features, such as an integrated SCSI controller with RAID capabilities, and to simplify the installation of your operating system. For information about using this CD, see “Using the ServerGuide Setup and Installation CD” on page 17.

- **ServeRAID Manager**

ServeRAID Manager is available as a stand-alone program and as an IBM Director extension. If a ServeRAID adapter is installed in your server or if you are using the RAID capabilities of the SCSI controller, use ServeRAID Manager to define and configure your disk-array subsystem *before* you install the operating system. For information about using this program, see “Using ServeRAID Manager” on page 20.

- **LSI Logic Configuration Utility**

Use this to configure the integrated SCSI controller with RAID capabilities and the devices that are attached to it. For information about using this utility program, see “Using the LSI Logic Configuration Utility program” on page 21.

- **Ethernet controller configuration process**

For information about configuring the Ethernet controller, see “Configuring the Gigabit Ethernet controller” on page 22.

Using the Configuration/Setup Utility program

Use the Configuration/Setup Utility program to:

- View configuration information
- View and change assignments for devices and I/O ports
- Set the date and time
- Set and change passwords and Remote Control Security settings
- Set the startup characteristics of the server and the order of startup devices
- Set and change settings for advanced hardware features
- View and clear error logs

Starting the Configuration/Setup Utility program

Complete the following steps to start the Configuration/Setup Utility program:

1. Turn on the server.
2. When the prompt Press F1 for Configuration/Setup appears, press F1. If you have set both a power-on password and an administrator password, you must type the administrator password to access the full Configuration/Setup Utility

menu. If you do not type the administrator password, a limited Configuration/Setup Utility menu is available.

3. Select settings to view or change.

Configuration/Setup Utility menu choices

The following choices are on the Configuration/Setup Utility main menu. Depending on the version of the BIOS code in your server, some menu choices might differ slightly from these descriptions.

- **System Summary**

Select this choice to view configuration information, including the type, speed, and cache sizes of the microprocessors and the amount of installed memory. When you make configuration changes through other options in the Configuration/Setup Utility program, the changes are reflected in the system summary; you cannot change settings directly in the system summary.

This choice is on the full and limited Configuration/Setup Utility menu.

- **System Information**

Select this choice to view information about your server. When you make changes through other options in the Configuration/Setup Utility program, some of those changes are reflected in the system information; you cannot change settings directly in the system information.

This choice is on the full Configuration/Setup Utility menu only.

- **Product Data**

Select this choice to view the machine type and model of your server, the serial number, and the revision level or issue date of the BIOS and diagnostics code stored in electrically erasable programmable ROM (EEPROM).

- **System Card Data**

Select this choice to view information about the system board.

- **Devices and I/O Ports**

Select this choice to view or change assignments for devices and input/output (I/O) ports.

Select this choice to enable or disable integrated SCSI and Ethernet controllers and all standard ports (such as serial and parallel). **Enable** is the default setting for all controllers. If you disable a device, it cannot be configured, and the operating system will not be able to detect it (this is equivalent to disconnecting the device). If you disable the integrated SCSI controller and no SCSI adapter is installed, the server will have no SCSI capability. If you disable the integrated Ethernet controller and no Ethernet adapter is installed, the server will have no Ethernet capability.

This choice is on the full Configuration/Setup Utility menu only.

- **Date and Time**

Select this choice to set the date and time in the server, in 24-hour format (*hour:minute:second*).

- **System Security**

Select this choice to set passwords. See “Passwords” on page 16 for more information about passwords. You can also enable the chassis-intrusion detector to alert you each time the server cover is removed.

- **Power-on Password**

Select this choice to set or change a power-on password. See “Power-on password” on page 17 for more information.

- **Administrator Password**

Select this choice to set or change an administrator password. An administrator password is intended to be used by a system administrator; it limits access to the full Configuration/Setup Utility menu. If an administrator password is set, the full Configuration/Setup Utility menu is available only if you type the administrator password at the password prompt. See “Administrator password” on page 17 for more information.

- **Start Options**

Select this choice to view or change the start options. Changes in the start options take effect when you restart the server.

You can set keyboard operating characteristics, such as the keyboard speed, and you can specify whether the server starts with the keyboard number lock on or off. You can enable the server to run without a diskette drive, monitor, or keyboard.

The startup sequence specifies the order in which the server checks devices to find a boot record. The server starts from the first boot record that it finds. If your server has Wake on LAN hardware and software and the operating system supports Wake on LAN functions, you can specify a startup sequence for the Wake on LAN functions. You can also specify whether the integrated SCSI controller or a PCI SCSI adapter has boot precedence.

If you enable the boot fail count, the BIOS default settings will be restored after three consecutive failures to find a boot record.

You can enable a virus-detection test that checks for changes in the boot record when the server starts.

- **Advanced Setup**

Select this choice to change settings for advanced hardware features.

Important: The server might malfunction if these options are incorrectly configured. Follow the instructions on the screen carefully.

- **Power Management Setup**

Select this choice to enable or disable system power settings. This includes automatic power-on settings such as the Wake on LAN feature.

- **Chipset Feature**

Select this choice to modify settings that control features of the core chip set on the system board.

Attention: Do not make changes in the Chipset Feature option unless directed to do so by an IBM authorized service representative.

- **Processor Control**

Select this choice to enable or disable the microprocessor cache and hyper-threading.

Attention: Do not make changes in the Processor Control option unless directed to do so by an IBM authorized service representative.

- **PC Health Status**

Select this choice to display the server temperature and voltage status, and fan speeds.

- **Error Logs**

Select **POST Error Log** to view the three most recent error codes and messages that the system generated during POST.

Select **Clear event/error logs** from the **POST Error Log** menu to clear the POST Error Log.

- **Save Settings**
Select this choice to save the changes you have made in the settings.
- **Restore Settings**
Select this choice to cancel the changes you have made in the settings and restore the previous settings.
- **Load Default Settings**
Select this choice to cancel the changes you have made in the settings and restore the factory settings.
- **Exit Setup**
Select this choice to exit from the Configuration/Setup Utility program. If you have not saved the changes you have made in the settings, you are asked whether you want to save the changes or exit without saving them.

Passwords

From the **System Security** choice, you can set, change, and delete a power-on password and an administrator password. The **System Security** choice is on the full Configuration/Setup menu only.

If you set only a power-on password, you must type the power-on password to complete the system startup, and you have access to the full Configuration/Setup Utility menu.

An administrator password is intended to be used by a system administrator; it limits access to the full Configuration/Setup Utility menu. If you set only an administrator password, you do not have to type a password to complete the system startup, but you must type the administrator password to access the Configuration/Setup Utility menu.

If you set a power-on password for a user and an administrator password for a system administrator, you can type either password to complete the system startup. A system administrator who types the administrator password has access to the full Configuration/Setup Utility menu; the system administrator can give the user authority to set, change, and delete the power-on password. A user who types the power-on password has access to only the limited Configuration/Setup Utility menu; the user can set, change, and delete the power-on password, if the system administrator has given the user that authority.

If you forget the power-on password, you can regain access to the server in any of the following ways:

- If you have forgotten the user password and an administrator password is set, type the administrator password at the power-on prompt. Start the Configuration/Setup Utility program and change the user password.
- CAUTION:**
Before changing any switch settings or moving any jumpers, turn off the server; then, disconnect all power cords and external cables.
- Clear CMOS settings by changing the position of the CMOS recovery jumper (JBAT1). See the *Hardware Maintenance Manual and Troubleshooting Guide* on the IBM xSeries Documentation CD for instructions.
 - Remove the battery and then install the battery. See the *Option Installation Guide* on the IBM xSeries Documentation CD for instructions.

Power-on password

If a power-on password is set, when you turn on the server, the system startup will not be completed until you type the power-on password. You can use any combination of up to seven characters (A–Z, a–z, and 0–9) for the password.

Administrator password

If an administrator password is set, you must type the administrator password for access to the full Configuration/Setup Utility menu. You can use any combination of up to seven characters (A–Z, a–z, and 0–9) for the password.

Using the ServerGuide Setup and Installation CD

The *ServerGuide Setup and Installation CD* includes an easy-to-use setup and installation program that is specifically designed for your IBM server. The ServerGuide program detects the server model and hardware options that are installed and uses that information during setup to configure the hardware. The ServerGuide program simplifies operating system installations by providing updated device drivers and, in some cases, installing them automatically.

If a later version of the ServerGuide program is available, you can download a free image of the *ServerGuide Setup and Installation CD*, or you can purchase the CD. To download the image, go to the IBM ServerGuide Web page at <http://www.ibm.com/pc/qtechinfo/MIGR-4ZKPPT.html>. To purchase the latest *ServerGuide Setup and Installation CD*, go to the ServerGuide fulfillment Web site at <http://www.ibm.com/pc/coupon/>.

The ServerGuide program has the following features to make setup easier:

- An easy-to-use interface with online help
- Diskette-free setup, and configuration programs that are based on detected hardware
- Performance Optimizer program, which easily tunes your SCSI RAID adapter settings for your server environment
- A system BIOS update program, which updates the BIOS code directly from the CD
- Device drivers that are provided for your server model and detected hardware
- Operating system partition size and file-system type that are selectable during setup

ServerGuide features

Features and functions can vary slightly with different versions of the ServerGuide program. To learn more about the version that you have, start the *ServerGuide Setup and Installation CD* and view the online overview. Not all features are supported on all server models.

The ServerGuide program requires a supported IBM server with an enabled startable (bootable) CD-ROM drive. In addition to the *ServerGuide Setup and Installation CD*, you must have your operating system CD to install your operating system.

The ServerGuide program has the following features:

- Sets system date and time.
- Detects an installed SCSI RAID adapter or controller and runs the SCSI RAID configuration program. (Does not apply to the integrated SCSI controller with RAID capabilities.)

- Updates the licensed internal code (firmware) level without diskettes.
- Checks the system BIOS code and microcode (firmware) levels of supported options to determine whether a later level is available from the CD. You can perform updates without using diskettes.
- Provides the Performance Optimizer program to easily tune your SCSI RAID adapter settings for your server environment.
- Creates a System Partition on the default drive. You can run server-specific utility programs after setup.
- Detects installed hardware options and provides updated device drivers for most adapters and devices.
- Creates a setup-replication diskette for replicating setup selections for other servers of the same model.
- Provides diskette-free installation for supported operating systems.
- Provides a replicated installation path for multiple installations of supported operating systems.
- Includes an online README file with links to tips for your hardware and operating system installation.

Setup and configuration overview

When you use the *ServerGuide Setup and Installation* CD, you do not need setup diskettes. You can use the CD to configure any supported IBM server model. The ServerGuide program checks your system BIOS, service processors, and other system hardware to determine if system updates are available. The setup program provides a list of tasks that are required to set up your server model. On SCSI RAID servers, you can run the SCSI RAID configuration program to create logical drives.

Note: Features and functions can vary slightly with different versions of the ServerGuide program.

When you start the *ServerGuide Setup and Installation* CD, the program performs the following tasks:

- The ServerGuide program prompts you for your language, country, and keyboard layout. (This information is stored and later passed to the operating system installation program.)
- The ServerGuide program displays choices for running the configuration programs. For example:
 - The Express Configuration method runs the required programs for your server, based on the hardware that is detected.
 - The Custom Configuration method displays all programs that are available for your server, and you decide which programs to run.
 - The Replicated Configuration method provides the option of duplicating your setup selections to other servers that are the same model.
- If you select the Custom Configuration method, the following features are optional. If you select the Express Configuration method, some or all of these features are run, depending on the hardware that is detected:
 - The Set Date and Time feature is provided so that you do not have to use the Configuration/Setup Utility program to access these settings.
 - The Clear Hard Disks feature is provided so you can delete all partitions on all hard disk drives. If the server has a SCSI RAID adapter installed, you can select to restore the configuration on the SCSI RAID adapter to the factory default settings.

- The ServerGuide program checks the server BIOS code and microcode (firmware) levels for supported options and then checks the CD for a newer level. The CD content might be newer than the BIOS code and firmware level. The ServerGuide program can perform a flash update of the BIOS code and supported microcode (firmware) options without using diskettes.
- The SCSI RAID configuration program starts, leading you through the entire configuration process.
- The Performance Optimizer program easily tunes your server for your environment.
- The ServerGuide program creates a System Partition on the default drive.
- The ServerGuide program displays a confirmation summary, so that you will know when you have completed all the required tasks. Then, you are ready to install your operating system.

Notes:

1. Plug and Play adapters are configured automatically. Non-Plug and Play adapters or non-IBM adapters might require switch settings, additional device drivers, and installation after the operating system is installed. See the documentation that comes with the adapter.
2. Diagnostics for your server come in BIOS code or on a separate diagnostics CD.

System Partition

The ServerGuide program creates a 50 MB System Partition on the default drive. The System Partition contains server-specific utility programs such as service processor disk operating system (DOS) utilities, system diagnostics, flash BIOS updates, and other programs. Programs in the System Partition vary by server model, and not all server models run utility programs from the System Partition. To determine which ones do, start the *ServerGuide Setup and Installation* CD and view the online overview.

After setup is complete, you can access programs in the System Partition by restarting the server and pressing Alt+F1 when the prompt is displayed. The **System Partition** menu displays the programs that are available on your server model.

Typical operating system installation

You can use the ServerGuide program to shorten your installation time. The ServerGuide program provides the device drivers that are required for your hardware and for the operating system that you are installing. This section describes a typical ServerGuide operating system installation.

Note: Features and functions can vary slightly with different versions of the ServerGuide program.

1. After you have completed the setup process, the operating system installation program starts. (You will need your operating system CD to complete the installation.)
2. The ServerGuide program stores information about the server model, service processor, hard disk drive controllers, and network adapters. Then, the program checks the CD for newer device drivers. This information is stored and then passed to the operating system installation program.

3. With some operating system installations, you can create an operating system replication diskette for setting up additional servers. This diskette contains the Internet protocol (IP) address, server name, and other selections.
4. The ServerGuide program presents operating system partition options that are based on your operating system selection and the installed hard disk drives.
5. If you are installing the operating system from diskette, the ServerGuide program lists the diskettes that you must create and the optional diskettes that you might want to create. The diskettes that you can create are the device-driver diskettes for the installed adapters or controllers.
6. The ServerGuide program prompts you to insert your operating system CD and restart the server. At this point, the installation program for the operating system takes control to complete the installation.

Setting up or updating multiple servers

You can use the ServerGuide program to create diskettes that help you set up or update multiple servers. You can modify information on the diskettes as you use them to set up or update other servers.

Note: Availability and function can vary by server model and by the hardware that is installed.

You can create a setup-replication diskette, which contains your hardware configuration selections. Use this diskette to replicate selections to other servers that are of the same model.

You can create an operating system replication diskette, which contains information that you need to complete multiple installations. Not all operating systems support operating system replication diskettes.

Installing your operating system without ServerGuide

If you have already configured the server hardware and you decide not to use the ServerGuide program to install your operating system, complete the following steps to download the latest operating system installation instructions from the IBM Support Web page:

1. Go to <http://www.ibm.com/pc/support/>.
2. Under **Browse**, click **Servers**.
3. From the **Family** drop-down list, select your server model.
4. If operating system installation instructions are available for your server model, **OS installation** is in the list in the upper-left corner of the Web page. Click **OS installation** and select the instructions for your operating system.

Using ServeRAID Manager

You can use the ServeRAID Manager program, which is on the *IBM ServeRAID Support CD*, to:

- Configure a redundant array of independent disks (RAID)
- Restore a SCSI hard disk drive to factory-default settings, erasing all data from the disk
- View your RAID configuration and associated devices
- Monitor operation of your RAID controllers

You can run ServeRAID Manager in startable-CD mode from the *IBM ServeRAID Support CD* or as an installed program. For information about installing ServeRAID Manager, see the documentation on the CD.

See the ServeRAID documentation on the *IBM ServeRAID Support CD* for additional information about RAID technology and instructions for using ServeRAID Manager. The *Installation Guide* for your server also contains instructions for using ServeRAID Manager to configure your integrated SCSI controller with RAID capabilities.

Notes:

1. The integrated SCSI controller with RAID capabilities in your server supports only RAID level 1. Installing an optional ServeRAID-5i controller provides additional RAID levels.
2. If you install a different type of RAID adapter in your server, use the configuration method supplied with the RAID adapter to view or change SCSI settings for attached devices.

Before you install your operating system, you must configure the controller that is attached to the hard disk drives. Use the configuration program on the *IBM ServeRAID Support CD* to configure the integrated SCSI controller with RAID capabilities or to configure an optional IBM ServeRAID controller.

Notes:

1. You cannot use the *ServerGuide Setup and Installation CD* to configure the optional controllers.
2. To update the firmware and BIOS code for an optional ServeRAID controller, you must use the *IBM ServeRAID Support CD* that comes with the ServeRAID option.

Using the LSI Logic Configuration Utility program

LSI Logic Configuration is a built-in, menu-driven configuration utility program that you can use to:

- Perform a low-level format of a SCSI hard disk drive
- Set a SCSI device scan order
- View or change SCSI IDs for attached devices
- Set SCSI protocol parameters on SCSI hard disk drives

Notes:

1. The integrated SCSI controller with RAID capabilities in your server supports redundant array of independent disks (RAID). You can use the LSI Logic Configuration Utility program to configure RAID level 1 for a single pair of attached devices.
2. If you install a different type of RAID adapter in your server, use the configuration method supplied with the RAID adapter to view or change SCSI settings for attached devices.

The following sections provide the instructions for starting and running the LSI Logic Configuration Utility program and performing selected functions.

Starting the LSI Logic Configuration Utility program

Complete the following steps to start the LSI Logic Configuration Utility program:

1. Turn on the server.

2. When the prompt <<< Press <CTRL><C> to start LSI Logic Configuration Utility >>> appears, press Ctrl+C. If you have set an administrator password you are prompted to type the password.
3. Use the arrow keys to select a controller (channel) from the list of adapters; then, press Enter.
4. Follow the instructions on the screen to change the settings of the selected items; then, press Enter. The **Device Properties** and **Mirroring Properties** choices produce additional screens of parameters to review or change.

Formatting a SCSI hard disk drive

Low-level formatting removes all data from the hard disk. If there is data you want to save, back up the hard disk before performing this procedure. Complete the following steps to format a drive.

Note: Before you format a SCSI hard disk, make sure that it is not part of a mirrored pair. From the list of adapters, select the controller (channel) for the drive to format. Select **Mirroring Properties** and make sure the mirroring value for the drive is set to **None**.

1. From the list of adapters, select the controller (channel) for the drive to format.
2. Select **Device Properties**.
3. Use the arrow keys (↑ or ↓) to highlight the drive to format.
4. Use the arrow keys (← or →) or the End key to scroll to the right.
5. Select **Format**; then, press Enter to begin the low-level formatting operation.

Configuring the Gigabit Ethernet controller

The Ethernet controller is integrated on the system board. It provides an interface for connecting to a 10-Mbps, 100-Mbps, or 1000-Mbps network and provides full duplex (FDX) capability, which enables simultaneous transmission and reception of data on the network. If the Ethernet port in the server supports auto-negotiation, the controller detects the data-transfer rate of the network (10BASE-T, 100BASE-TX, or 1000BASE-T) and automatically operates at that rate, in full-duplex or half-duplex mode, as appropriate. The Ethernet controller supports optional modes, such as teaming, priority packets, load balancing, fault tolerance, and virtual LANs, which provide better performance, security, and throughput. These modes apply to the integrated Ethernet controller and to controllers on supported Ethernet adapters.

You do not need to set any jumpers or configure the controller. However, you must install a device driver to enable the operating system to address the controller. The device drivers are available on the *Broadcom NetXtreme Gigabit Ethernet Software CD*. For the latest device drivers and information about configuring your Ethernet controller, go to the IBM Support Web site at <http://www.ibm.com/pc/support>.

Appendix A. Getting help and technical assistance

If you need help, service, or technical assistance or just want more information about IBM products, you will find a wide variety of sources available from IBM to assist you. This appendix contains information about where to go for additional information about IBM and IBM products, what to do if you experience a problem with your xSeries or IntelliStation system, and whom to call for service, if it is necessary.

Before you call

Before you call, make sure that you have taken these steps to try to solve the problem yourself:

- Check all cables to make sure that they are connected.
- Check the power switches to make sure that the system is turned on.
- Use the troubleshooting information in your system documentation, and use the diagnostic tools that come with your system.
- Go to the IBM Support Web site at <http://www.ibm.com/pc/support/> to check for technical information, hints, tips, and new device drivers.
- Use an IBM discussion forum on the IBM Web site to ask questions.

You can solve many problems without outside assistance by following the troubleshooting procedures that IBM provides in the online help or in the publications that are provided with your system and software. The information that comes with your system also describes the diagnostic tests that you can perform. Most xSeries and IntelliStation systems, operating systems, and programs come with information that contains troubleshooting procedures and explanations of error messages and error codes. If you suspect a software problem, see the information for the operating system or program.

Using the documentation

Information about your IBM xSeries or IntelliStation system and preinstalled software, if any, is available in the documentation that comes with your system. That documentation includes printed books, online books, README files, and help files. See the troubleshooting information in your system documentation for instructions for using the diagnostic programs. The troubleshooting information or the diagnostic programs might tell you that you need additional or updated device drivers or other software. IBM maintains pages on the World Wide Web where you can get the latest technical information and download device drivers and updates. To access these pages, go to <http://www.ibm.com/pc/support/> and follow the instructions. Also, you can order publications through the IBM Publications Ordering System at <http://www.elink.ibm.com/public/applications/publications/cgibin/pbi.cgi>.

Getting help and information from the World Wide Web

On the World Wide Web, the IBM Web site has up-to-date information about IBM xSeries and IntelliStation products, services, and support. The address for IBM xSeries information is <http://www.ibm.com/eserver/xseries/>. The address for IBM IntelliStation information is <http://www.ibm.com/pc/intellistation/>.

You can find service information for your IBM products, including supported options, at <http://www.ibm.com/pc/support/>. If you click **Profile** from the support page, you

can create a customized support page. The support page has many sources of information and ways for you to solve problems, including:

- Diagnosing problems, using the IBM Online Assistant
- Downloading the latest device drivers and updates for your products
- Viewing Frequently Asked Questions (FAQ)
- Viewing hints and tips to help you solve problems
- Participating in IBM discussion forums
- Setting up e-mail notification of technical updates about your products

Software service and support

Through IBM Support Line, you can get telephone assistance, for a fee, with usage, configuration, and software problems with xSeries servers, IntelliStation workstations, and appliances. For information about which products are supported by Support Line in your country, go to <http://www.ibm.com/services/sl/products/>.

For more information about Support Line and other IBM services, go to <http://www.ibm.com/services/>, or go to <http://www.ibm.com/planetwide/> for support telephone numbers.

Hardware service and support

You can receive hardware service through IBM Integrated Technology Services or through your IBM reseller, if your reseller is authorized by IBM to provide warranty service. Go to <http://www.ibm.com/planetwide/> for support telephone numbers.

In the U.S. and Canada, hardware service and support is available 24 hours a day, 7 days a week. In the U.K., these services are available Monday through Friday, from 9 a.m. to 6 p.m.

Appendix B. Warranty information

This section contains information about your warranty period and the service and support that are provided by your warranty.

Warranty period

The warranty period varies by machine type and country or region.

Contact your place of purchase for warranty service information. Some IBM Machines are eligible for on-site warranty service depending on the country or region where service is performed.

Prior to on-site warranty service, you are required to go through problem determination with an IBM service specialist call center technician.

This paragraph applies only to products with a warranty period of 3 years on parts and 1 year on labor. A warranty period of 3 years on parts and 1 year on labor means that IBM will provide warranty service without charge for:

1. parts and labor during the first year of the warranty period
2. parts only, on an exchange basis, in the second and third years of the warranty period. IBM will charge you for any labor it provides in performance of the repair or replacement.

The IBM Machine Warranties Web site at http://www.ibm.com/servers/support/machine_warranties/ contains a worldwide overview of the IBM Statement of Limited Warranty for IBM Machines, a glossary of terms used in the Statement of Limited Warranty, Frequently Asked Questions (FAQ), and links to Product Support Web pages. The IBM Statement of Limited Warranty is available from this Web site in 29 languages in Portable Document Format (PDF).

Machine - IBM @server xSeries 225 Type 8647

Country or region	Warranty period	Service delivery method
Worldwide	Parts - 1 year, labor - 1 year	On-site

Problem determination

Prior to on-site warranty service, you are required to go through problem determination with an IBM service specialist call center technician. The service specialist will run diagnostic tests on the hardware and check the software.

Running diagnostics

The IBM service specialist will help you determine whether your equipment is functioning as specified. It might be necessary to isolate the failing xSeries, Netfinity®, or IntelliStation® system; IBM component; or both from any active production environment to run diagnostics and perform defect-isolation programs. You are responsible for making the system, IBM component, or both available for running diagnostics and defect-isolation programs.

Checking software

The IBM service specialist will help you ensure that the correct BIOS code, firmware, device drivers, and other supporting IBM software are installed and

correctly configured. It might be necessary to manually gather information about the relevant software levels or run IBM-approved utility programs to gather this information. It might be necessary to isolate the failing system from any active production environment to gather this information. You are responsible, with assistance from the service specialist, for gathering this information. The IBM Statement of Limited Warranty does not include on-site assistance with this activity.

Warranty service and support

With the original purchase of an IBM xSeries or IntelliStation system, you have access to extensive service and support. During the IBM Machine warranty period, you may call IBM or your reseller for problem-determination assistance under the terms of the IBM Statement of Limited Warranty.

The following services are available during the warranty period:

- **Problem determination** - Trained personnel are available to assist you with determining if you have a hardware problem and deciding what action is necessary to fix the problem.
- **IBM hardware repair** - If the problem is determined to be caused by IBM hardware under warranty, trained service personnel are available to provide the applicable level of service, either on-site or at an IBM service center as determined by IBM.
- **Engineering Change management** - Occasionally, there might be changes that are required after a product has been shipped from IBM. In those instances, IBM will make Engineering Changes (ECs) available that apply to your hardware.
- **Customer replaceable units (CRUs)** - Some parts of IBM servers are designated as customer replaceable units. IBM ships CRUs to you for replacement by you. CRUs include keyboards, monitors, memory, diskette drives, hard disk drives, and mice (this list is not inclusive of all CRUs).

The following items are not covered under warranty service:

- Replacement or use of non-IBM parts. All IBM parts contain a 7-character identification in the format IBM FRU XXXXXXXX.
- Identification of software problem sources.
- Installation of customer replaceable units (CRUs).
- Installation and configuration of BIOS code, firmware, or device drivers that are designated as customer installable.

See the IBM Statement of Limited Warranty for a full explanation of IBM warranty terms. Be sure to retain your proof of purchase to obtain warranty service.

Please have the following information ready when you call:

- The machine type and model of your IBM hardware product (if available)
- Serial numbers of your IBM hardware products
- A description of the problem
- The exact wording of any error messages
- Hardware and software configuration information

International Warranty Service

If you travel with your xSeries or IntelliStation system or relocate it to a country where your system is sold and serviced by IBM or IBM resellers authorized to

perform warranty service, International Warranty Service (IWS) is available during the warranty period. Eligible IBM systems are identified by their four-digit machine types.

You can obtain IWS through the service delivery method (such as depot, carry-in, or on-site) provided in the servicing country. Service methods and procedures vary by country, and some service or parts might not be available in all countries. Service centers in certain countries might not be able to service all models of a particular machine type. In addition, some countries might have fees and restrictions that apply at the time of service.

To determine whether your system is eligible for IWS, go to <http://www.ibm.com/pc/support/> and click **Warranty lookup**.

Purchasing additional services

During and after the warranty period, you can purchase additional services, such as support for IBM and non-IBM hardware, operating systems, and application programs; network setup and configuration; upgraded or extended hardware repair services; and custom installations. Service availability and service name might vary by country or region.

For more information about these services, contact your IBM marketing representative.

IBM Statement of Limited Warranty Z125-4753-06 8/2000

Part 1 - General Terms

This Statement of Limited Warranty includes Part 1 - General Terms and Part 2 - Country-unique Terms. The terms of Part 2 replace or modify those of Part 1. The warranties provided by IBM in this Statement of Limited Warranty apply only to Machines you purchase for your use, and not for resale, from IBM or your reseller. The term "Machine" means an IBM machine, its features, conversions, upgrades, elements, or accessories, or any combination of them. The term "Machine" does not include any software programs, whether pre-loaded with the Machine, installed subsequently or otherwise. Unless IBM specifies otherwise, the following warranties apply only in the country where you acquire the Machine. Nothing in this Statement of Limited Warranty affects any statutory rights of consumers that cannot be waived or limited by contract. If you have any questions, contact IBM or your reseller.

The IBM Warranty for Machines: IBM warrants that each Machine 1) is free from defects in materials and workmanship and 2) conforms to IBM's Official Published Specifications ("Specifications"). The warranty period for a Machine is a specified, fixed period commencing on its Date of Installation. The date on your sales receipt is the Date of Installation unless IBM or your reseller informs you otherwise.

If a Machine does not function as warranted during the warranty period, and IBM or your reseller are unable to either 1) make it do so or 2) replace it with one that is at least functionally equivalent, you may return it to your place of purchase and your money will be refunded.

Extent of Warranty: The warranty does not cover the repair or exchange of a Machine resulting from misuse, accident, modification, unsuitable physical or operating environment, improper maintenance by you, or failure caused by a product for which IBM is not responsible. The warranty is voided by removal or alteration of Machine or parts identification labels.

THESE WARRANTIES ARE YOUR EXCLUSIVE WARRANTIES AND REPLACE ALL OTHER WARRANTIES OR CONDITIONS, EXPRESS OR IMPLIED, INCLUDING, BUT NOT LIMITED TO, THE IMPLIED WARRANTIES OR CONDITIONS OF MERCHANTABILITY AND FITNESS FOR A PARTICULAR PURPOSE. THESE WARRANTIES GIVE YOU SPECIFIC LEGAL RIGHTS AND YOU MAY ALSO HAVE OTHER RIGHTS WHICH VARY FROM JURISDICTION TO JURISDICTION. SOME JURISDICTIONS DO NOT ALLOW THE EXCLUSION OR LIMITATION OF EXPRESS OR IMPLIED WARRANTIES, SO THE ABOVE EXCLUSION OR LIMITATION MAY NOT APPLY TO YOU. IN THAT EVENT, SUCH WARRANTIES ARE LIMITED IN DURATION TO THE WARRANTY PERIOD. NO WARRANTIES APPLY AFTER THAT PERIOD.

Items Not Covered by Warranty: IBM does not warrant uninterrupted or error-free operation of a Machine. Any technical or other support provided for a Machine under warranty, such as assistance via telephone with "how-to" questions and those regarding Machine set-up and installation, will be provided **WITHOUT WARRANTIES OF ANY KIND.**

Warranty Service: To obtain warranty service for a Machine, contact IBM or your reseller. If you do not register your Machine with IBM, you may be required to present proof of purchase.

During the warranty period, IBM or your reseller, if approved by IBM to provide warranty service, provides without charge certain types of repair and exchange service to keep Machines in, or restore them to, conformance with their Specifications. IBM or your reseller will inform you of the available types of service for a Machine based on its country of installation. At its discretion, IBM or your reseller will 1) either repair or exchange the failing Machine and 2) provide the service either at your location or a service center. IBM or your reseller will also manage and install selected engineering changes that apply to the Machine.

Some parts of IBM Machines are designated as Customer Replaceable Units (called "CRUs"), e.g., keyboards, memory, or hard disk drives. IBM ships CRUs to you for replacement by you. You must return all defective CRUs to IBM within 30 days of your receipt of the replacement CRU. You are responsible for downloading designated Machine Code and Licensed Internal Code updates from an IBM Internet Web site or from other electronic media, and following the instructions that IBM provides.

When warranty service involves the exchange of a Machine or part, the item IBM or your reseller replaces becomes its property and the replacement becomes yours. You represent that all removed items are genuine and unaltered. The replacement may not be new, but will be in good working order and at least functionally equivalent to the item replaced. The replacement assumes the warranty service status of the replaced item. Many features, conversions, or upgrades involve the removal of parts and their return to IBM. A part that replaces a removed part will assume the warranty service status of the removed part.

Before IBM or your reseller exchanges a Machine or part, you agree to remove all features, parts, options, alterations, and attachments not under warranty service.

You also agree to

1. ensure that the Machine is free of any legal obligations or restrictions that prevent its exchange;
2. obtain authorization from the owner to have IBM or your reseller service a Machine that you do not own; and
3. where applicable, before service is provided:
 - a. follow the problem determination, problem analysis, and service request procedures that IBM or your reseller provides;
 - b. secure all programs, data, and funds contained in a Machine;
 - c. provide IBM or your reseller with sufficient, free, and safe access to your facilities to permit them to fulfill their obligations; and
 - d. inform IBM or your reseller of changes in a Machine's location.

IBM is responsible for loss of, or damage to, your Machine while it is 1) in IBM's possession or 2) in transit in those cases where IBM is responsible for the transportation charges.

Neither IBM nor your reseller is responsible for any of your confidential, proprietary or personal information contained in a Machine which you return to IBM or your reseller for any reason. You should remove all such information from the Machine prior to its return.

Limitation of Liability: Circumstances may arise where, because of a default on IBM's part or other liability, you are entitled to recover damages from IBM. In each such instance, regardless of the basis on which you are entitled to claim damages from IBM (including fundamental breach, negligence, misrepresentation, or other

contract or tort claim), except for any liability that cannot be waived or limited by applicable laws, IBM is liable for no more than

1. damages for bodily injury (including death) and damage to real property and tangible personal property; and
2. the amount of any other actual direct damages, up to the charges (if recurring, 12 months' charges apply) for the Machine that is subject of the claim. For purposes of this item, the term "Machine" includes Machine Code and Licensed Internal Code.

This limit also applies to IBM's suppliers and your reseller. It is the maximum for which IBM, its suppliers, and your reseller are collectively responsible.

UNDER NO CIRCUMSTANCES IS IBM LIABLE FOR ANY OF THE FOLLOWING: 1) THIRD-PARTY CLAIMS AGAINST YOU FOR DAMAGES (OTHER THAN THOSE UNDER THE FIRST ITEM LISTED ABOVE); 2) LOSS OF, OR DAMAGE TO, YOUR RECORDS OR DATA; OR 3) SPECIAL, INCIDENTAL, OR INDIRECT DAMAGES OR FOR ANY ECONOMIC CONSEQUENTIAL DAMAGES, LOST PROFITS OR LOST SAVINGS, EVEN IF IBM, ITS SUPPLIERS OR YOUR RESELLER IS INFORMED OF THEIR POSSIBILITY. SOME JURISDICTIONS DO NOT ALLOW THE EXCLUSION OR LIMITATION OF INCIDENTAL OR CONSEQUENTIAL DAMAGES, SO THE ABOVE LIMITATION OR EXCLUSION MAY NOT APPLY TO YOU.

Governing Law: Both you and IBM consent to the application of the laws of the country in which you acquired the Machine to govern, interpret, and enforce all of your and IBM's rights, duties, and obligations arising from, or relating in any manner to, the subject matter of this Agreement, without regard to conflict of law principles.

Part 2 - Country-unique Terms

AMERICAS

BRAZIL

Governing Law: *The following is added after the first sentence:* Any litigation arising from this Agreement will be settled exclusively by the court of Rio de Janeiro.

NORTH AMERICA

Warranty Service: *The following is added to this Section:* To obtain warranty service from IBM in Canada or the United States, call 1-800-IBM-SERV (426-7378).

CANADA

Governing Law: *The following replaces "laws of the country in which you acquired the Machine" in the first sentence:* laws in the Province of Ontario.

UNITED STATES

Governing Law: *The following replaces "laws of the country in which you acquired the Machine" in the first sentence:* laws of the State of New York.

ASIA PACIFIC

AUSTRALIA

The IBM Warranty for Machines: *The following paragraph is added to this Section:* The warranties specified in this Section are in addition to any rights you may have under the Trade Practices Act 1974 or other similar legislation and are only limited to the extent permitted by the applicable legislation.

Limitation of Liability: *The following is added to this Section:* Where IBM is in breach of a condition or warranty implied by the Trade Practices Act 1974 or other similar legislation, IBM's liability is limited to the repair or replacement of the goods or the supply of equivalent goods. Where that condition or warranty relates to right to sell, quiet possession or clear title, or the goods are of a kind ordinarily acquired for personal, domestic or household use or consumption, then none of the limitations in this paragraph apply.

Governing Law: *The following replaces "laws of the country in which you acquired the Machine" in the first sentence:* laws of the State or Territory.

CAMBODIA, LAOS, AND VIETNAM

Governing Law: *The following replaces "laws of the country in which you acquired the Machine" in the first sentence:* laws of the State of New York.

The following is added to this Section: Disputes and differences arising out of or in connection with this Agreement shall be finally settled by arbitration which shall be held in Singapore in accordance with the rules of the International Chamber of Commerce (ICC). The arbitrator or arbitrators designated in conformity with those rules shall have the power to rule on their own competence and on the validity of the Agreement to submit to arbitration. The arbitration award shall be final and binding for the parties without appeal and the arbitral award shall be in writing and set forth the findings of fact and the conclusions of law.

All proceedings shall be conducted, including all documents presented in such proceedings, in the English language. The number of arbitrators shall be three, with each side to the dispute being entitled to appoint one arbitrator.

The two arbitrators appointed by the parties shall appoint a third arbitrator before proceeding upon the reference. The third arbitrator shall act as chairman of the proceedings. Vacancies in the post of chairman shall be filled by the president of the ICC. Other vacancies shall be filled by the respective nominating party. Proceedings shall continue from the stage they were at when the vacancy occurred.

If one of the parties refuses or otherwise fails to appoint an arbitrator within 30 days of the date the other party appoints its, the first appointed arbitrator shall be the sole arbitrator, provided that the arbitrator was validly and properly appointed.

The English language version of this Agreement prevails over any other language version.

HONG KONG AND MACAU

Governing Law: *The following replaces "laws of the country in which you acquired the Machine" in the first sentence:* laws of Hong Kong Special Administrative Region.

INDIA

Limitation of Liability: *The following replaces items 1 and 2 of this Section:*

1. liability for bodily injury (including death) or damage to real property and tangible personal property will be limited to that caused by IBM's negligence;
2. as to any other actual damage arising in any situation involving nonperformance by IBM pursuant to, or in any way related to the subject of this Statement of Limited Warranty, IBM's liability will be limited to the charge paid by you for the individual Machine that is the subject of the claim.

JAPAN

Governing Law: *The following sentence is added to this Section:* Any doubts concerning this Agreement will be initially resolved between us in good faith and in accordance with the principle of mutual trust.

NEW ZEALAND

The IBM Warranty for Machines: *The following paragraph is added to this Section:* The warranties specified in this Section are in addition to any rights you may have under the Consumer Guarantees Act 1993 or other legislation which cannot be excluded or limited. The Consumer Guarantees Act 1993 will not apply in respect of any goods which IBM provides, if you require the goods for the purposes of a business as defined in that Act.

Limitation of Liability: *The following is added to this Section:* Where Machines are not acquired for the purposes of a business as defined in the Consumer Guarantees Act 1993, the limitations in this Section are subject to the limitations in that Act.

PEOPLE'S REPUBLIC OF CHINA (PRC)

Governing Law: *The following replaces this Section:* Both you and IBM consent to the application of the laws of the State of New York (except when local law requires otherwise) to govern, interpret, and enforce all your and IBM's rights, duties, and obligations arising from, or relating in any manner to, the subject matter of this Agreement, without regard to conflict of law principles.

Any disputes arising from or in connection with this Agreement will first be resolved by friendly negotiations, failing which either of us has the right to submit the dispute to the China International Economic and Trade Arbitration Commission in Beijing, the PRC, for arbitration in accordance with its arbitration rules in force at the time. The arbitration tribunal will consist of three arbitrators. The language to be used therein will be English and Chinese. An arbitral award will be final and binding on all the parties, and will be enforceable under the Convention on the Recognition and Enforcement of Foreign Arbitral Awards (1958).

The arbitration fee will be borne by the losing party unless otherwise determined by the arbitral award.

During the course of arbitration, this Agreement will continue to be performed except for the part which the parties are disputing and which is undergoing arbitration.

EUROPE, MIDDLE EAST, AFRICA (EMEA)

THE FOLLOWING TERMS APPLY TO ALL EMEA COUNTRIES: The terms of this Statement of Limited Warranty apply to Machines purchased from IBM or an IBM reseller.

Warranty Service: If you purchase an IBM Machine in Austria, Belgium, Denmark, Estonia, Finland, France, Germany, Greece, Iceland, Ireland, Italy, Latvia, Lithuania, Luxembourg, Netherlands, Norway, Portugal, Spain, Sweden, Switzerland or United Kingdom, you may obtain warranty service for that Machine in any of those countries from either (1) an IBM reseller approved to perform warranty service or (2) from IBM. If you purchase an IBM Personal Computer Machine in Albania, Armenia, Belarus, Bosnia and Herzegovina, Bulgaria, Croatia, Czech Republic, Georgia, Hungary, Kazakhstan, Kirghizia, Federal Republic of Yugoslavia, Former Yugoslav Republic of Macedonia (FYROM), Moldova, Poland, Romania, Russia, Slovak Republic, Slovenia, or Ukraine, you may obtain warranty service for that Machine in any of those countries from either (1) an IBM reseller approved to perform warranty service or (2) from IBM.

If you purchase an IBM Machine in a Middle Eastern or African country, you may obtain warranty service for that Machine from the IBM entity within the country of purchase, if that IBM entity provides warranty service in that country, or from an IBM reseller, approved by IBM to perform warranty service on that Machine in that country. Warranty service in Africa is available within 50 kilometers of an IBM authorized service provider. You are responsible for transportation costs for Machines located outside 50 kilometers of an IBM authorized service provider.

Governing Law: The applicable laws that govern, interpret and enforce rights, duties, and obligations of each of us arising from, or relating in any manner to, the subject matter of this Statement, without regard to conflict of laws principles, as well as Country-unique terms and competent court for this Statement are those of the country in which the warranty service is being provided, except that in 1) Albania, Bosnia-Herzegovina, Bulgaria, Croatia, Hungary, Former Yugoslav Republic of Macedonia, Romania, Slovakia, Slovenia, Armenia, Azerbaijan, Belarus, Georgia, Kazakhstan, Kyrgyzstan, Moldova, Russia, Tajikistan, Turkmenistan, Ukraine, and Uzbekistan, the laws of Austria apply; 2) Estonia, Latvia, and Lithuania, the laws of Finland apply; 3) Algeria, Benin, Burkina Faso, Cameroon, Cape Verde, Central African Republic, Chad, Congo, Djibouti, Democratic Republic of Congo, Equatorial Guinea, France, Gabon, Gambia, Guinea, Guinea-Bissau, Ivory Coast, Lebanon, Mali, Mauritania, Morocco, Niger, Senegal, Togo, and Tunisia, this Agreement will be construed and the legal relations between the parties will be determined in accordance with the French laws and all disputes arising out of this Agreement or related to its violation or execution, including summary proceedings, will be settled exclusively by the Commercial Court of Paris; 4) Angola, Bahrain, Botswana, Burundi, Egypt, Eritrea, Ethiopia, Ghana, Jordan, Kenya, Kuwait, Liberia, Malawi, Malta, Mozambique, Nigeria, Oman, Pakistan, Qatar, Rwanda, Sao Tome, Saudi Arabia, Sierra Leone, Somalia, Tanzania, Uganda, United Arab Emirates, United Kingdom, West Bank/Gaza, Yemen, Zambia, and Zimbabwe, this Agreement will be governed by English Law and disputes relating to it will be submitted to the exclusive jurisdiction of the English courts; and 5) in Greece, Israel, Italy, Portugal, and Spain any legal claim arising out of this Statement will be brought before, and finally settled by, the competent court of Athens, Tel Aviv, Milan, Lisbon, and Madrid, respectively.

THE FOLLOWING TERMS APPLY TO THE COUNTRY SPECIFIED:

AUSTRIA AND GERMANY

The IBM Warranty for Machines: *The following replaces the first sentence of the first paragraph of this Section:* The warranty for an IBM Machine covers the functionality of the Machine for its normal use and the Machine's conformity to its Specifications.

The following paragraphs are added to this Section:

The minimum warranty period for Machines is six months. In case IBM or your reseller is unable to repair an IBM Machine, you can alternatively ask for a partial refund as far as justified by the reduced value of the unrepaired Machine or ask for a cancellation of the respective agreement for such Machine and get your money refunded.

Extent of Warranty: *The second paragraph does not apply.*

Warranty Service: *The following is added to this Section:* During the warranty period, transportation for delivery of the failing Machine to IBM will be at IBM's expense.

Limitation of Liability: *The following paragraph is added to this Section:* The limitations and exclusions specified in the Statement of Limited Warranty will not apply to damages caused by IBM with fraud or gross negligence and for express warranty.

The following sentence is added to the end of item 2: IBM's liability under this item is limited to the violation of essential contractual terms in cases of ordinary negligence.

EGYPT

Limitation of Liability: *The following replaces item 2 in this Section:* as to any other actual direct damages, IBM's liability will be limited to the total amount you paid for the Machine that is the subject of the claim. For purposes of this item, the term "Machine" includes Machine Code and Licensed Internal Code.

Applicability of suppliers and resellers (unchanged).

FRANCE

Limitation of Liability: *The following replaces the second sentence of the first paragraph of this Section:* In such instances, regardless of the basis on which you are entitled to claim damages from IBM, IBM is liable for no more than: *(items 1 and 2 unchanged).*

IRELAND

Extent of Warranty: *The following is added to this Section:* Except as expressly provided in these terms and conditions, all statutory conditions, including all warranties implied, but without prejudice to the generality of the foregoing all warranties implied by the Sale of Goods Act 1893 or the Sale of Goods and Supply of Services Act 1980 are hereby excluded.

Limitation of Liability: *The following replaces items one and two of the first paragraph of this Section:* 1. death or personal injury or physical damage to your real property solely caused by IBM's negligence; and 2. the amount of any other actual direct damages, up to 125 percent of the charges (if recurring, the 12 months' charges apply) for the Machine that is the subject of the claim or which otherwise gives rise to the claim.

Applicability of suppliers and resellers (unchanged).

The following paragraph is added at the end of this Section: IBM's entire liability and your sole remedy, whether in contract or in tort, in respect of any default shall be limited to damages.

ITALY

Limitation of Liability: *The following replaces the second sentence in the first paragraph: In each such instance unless otherwise provided by mandatory law, IBM is liable for no more than: 1. (unchanged) 2. as to any other actual damage arising in all situations involving nonperformance by IBM pursuant to, or in any way related to the subject matter of this Statement of Warranty, IBM's liability, will be limited to the total amount you paid for the Machine that is the subject of the claim. Applicability of suppliers and resellers (unchanged).*

The following replaces the third paragraph of this Section: Unless otherwise provided by mandatory law, IBM and your reseller are not liable for any of the following: (items 1 and 2 unchanged) 3) indirect damages, even if IBM or your reseller is informed of their possibility.

SOUTH AFRICA, NAMIBIA, BOTSWANA, LESOTHO AND SWAZILAND

Limitation of Liability: *The following is added to this Section: IBM's entire liability to you for actual damages arising in all situations involving nonperformance by IBM in respect of the subject matter of this Statement of Warranty will be limited to the charge paid by you for the individual Machine that is the subject of your claim from IBM.*

UNITED KINGDOM

Limitation of Liability: *The following replaces items 1 and 2 of the first paragraph of this Section:*

1. death or personal injury or physical damage to your real property solely caused by IBM's negligence;
2. the amount of any other actual direct damages or loss, up to 125 percent of the charges (if recurring, the 12 months' charges apply) for the Machine that is the subject of the claim or which otherwise gives rise to the claim;

The following item is added to this paragraph: 3. breach of IBM's obligations implied by Section 12 of the Sale of Goods Act 1979 or Section 2 of the Supply of Goods and Services Act 1982.

Applicability of suppliers and resellers (unchanged).

The following is added to the end of this Section: IBM's entire liability and your sole remedy, whether in contract or in tort, in respect of any default shall be limited to damages.

Appendix C. Notices

This publication was developed for products and services offered in the U.S.A.

IBM may not offer the products, services, or features discussed in this document in other countries. Consult your local IBM representative for information on the products and services currently available in your area. Any reference to an IBM product, program, or service is not intended to state or imply that only that IBM product, program, or service may be used. Any functionally equivalent product, program, or service that does not infringe any IBM intellectual property right may be used instead. However, it is the user's responsibility to evaluate and verify the operation of any non-IBM product, program, or service.

IBM may have patents or pending patent applications covering subject matter described in this document. The furnishing of this document does not give you any license to these patents. You can send license inquiries, in writing, to:

*IBM Director of Licensing
IBM Corporation
North Castle Drive
Armonk, NY 10504-1785
U.S.A.*

INTERNATIONAL BUSINESS MACHINES CORPORATION PROVIDES THIS PUBLICATION "AS IS" WITHOUT WARRANTY OF ANY KIND, EITHER EXPRESS OR IMPLIED, INCLUDING, BUT NOT LIMITED TO, THE IMPLIED WARRANTIES OF NON-INFRINGEMENT, MERCHANTABILITY OR FITNESS FOR A PARTICULAR PURPOSE. Some states do not allow disclaimer of express or implied warranties in certain transactions, therefore, this statement may not apply to you.

This information could include technical inaccuracies or typographical errors. Changes are periodically made to the information herein; these changes will be incorporated in new editions of the publication. IBM may make improvements and/or changes in the product(s) and/or the program(s) described in this publication at any time without notice.

Any references in this publication to non-IBM Web sites are provided for convenience only and do not in any manner serve as an endorsement of those Web sites. The materials at those Web sites are not part of the materials for this IBM product, and use of those Web sites is at your own risk.

IBM may use or distribute any of the information you supply in any way it believes appropriate without incurring any obligation to you.

Edition notice

**© COPYRIGHT INTERNATIONAL BUSINESS MACHINES CORPORATION, 2002.
All rights reserved.**

Note to U.S. Government Users — Documentation related to restricted rights — Use, duplication or disclosure is subject to restrictions set forth in GSA ADP Schedule Contract with IBM Corp.

Trademarks

The following terms are trademarks of International Business Machines Corporation in the United States, other countries, or both:

Active PCI	OS/2 WARP
Active PCI-X	Predictive Failure Analysis
Alert on LAN	ServeRAID
Chipkill	ServerGuide
EtherJet	ServerProven
e-business logo	TechConnect
HelpCenter	Tivoli
HelpWare	Tivoli Enterprise
IBM	Update Connector
Light Path Diagnostics	Wake on LAN
NetBAY	X-Architecture
NetView	xSeries

Lotus and Domino are trademarks of Lotus Development Corporation and/or IBM Corporation in the United States, other countries, or both.

ActionMedia, MMX, LANDesk, Pentium, and ProShare are trademarks of Intel Corporation in the United States, other countries, or both.

Microsoft, Windows, Windows NT, and the Windows logo are trademarks of Microsoft Corporation in the United States, other countries, or both.

UNIX is a registered trademark of The Open Group in the United States and other countries.

Java and all Java-based trademarks and logos are trademarks or registered trademarks of Sun Microsystems, Inc. in the United States, other countries, or both.

Linux is a registered trademark of Linus Torvalds.

Other company, product, or service names may be the trademarks or service marks of others.

Important notes

Processor speeds indicate the internal clock speed of the microprocessor; other factors also affect application performance.

CD-ROM drive speeds list the variable read rate. Actual speeds vary and are often less than the maximum possible.

When referring to processor storage, real and virtual storage, or channel volume, KB stands for approximately 1000 bytes, MB stands for approximately 1000000 bytes, and GB stands for approximately 1000000000 bytes.

When referring to hard disk drive capacity or communications volume, MB stands for 1 000 000 bytes, and GB stands for 1 000 000 000 bytes. Total user-accessible capacity may vary depending on operating environments.

Maximum internal hard disk drive capacities assume the replacement of any standard hard disk drives and population of all hard disk drive bays with the largest currently supported drives available from IBM.

Maximum memory may require replacement of the standard memory with an optional memory module.

IBM makes no representation or warranties regarding non-IBM products and services that are ServerProven[®], including but not limited to the implied warranties of merchantability and fitness for a particular purpose. These products are offered and warranted solely by third parties.

Unless otherwise stated, IBM makes no representations or warranties with respect to non-IBM products. Support (if any) for the non-IBM products is provided by the third party, not IBM.

Some software may differ from its retail version (if available), and may not include user manuals or all program functionality.

Electronic emission notices

Federal Communications Commission (FCC) statement

Note: This equipment has been tested and found to comply with the limits for a Class A digital device, pursuant to Part 15 of the FCC Rules. These limits are designed to provide reasonable protection against harmful interference when the equipment is operated in a commercial environment. This equipment generates, uses, and can radiate radio frequency energy and, if not installed and used in accordance with the instruction manual, may cause harmful interference to radio communications. Operation of this equipment in a residential area is likely to cause harmful interference, in which case the user will be required to correct the interference at his own expense.

Properly shielded and grounded cables and connectors must be used in order to meet FCC emission limits. Properly shielded and grounded cables and connectors must be used in order to meet FCC emission limits. IBM is not responsible for any radio or television interference caused by using other than recommended cables and connectors or by using other than recommended cables and connectors or by unauthorized changes or modifications to this equipment. Unauthorized changes or modifications could void the user's authority to operate the equipment.

This device complies with Part 15 of the FCC Rules. Operation is subject to the following two conditions: (1) this device may not cause harmful interference, and (2) this device must accept any interference received, including interference that may cause undesired operation.

Industry Canada Class A emission compliance statement

This Class A digital apparatus complies with Canadian ICES-003.

Avis de conformité à la réglementation d'Industrie Canada

Cet appareil numérique de la classe A est conforme à la norme NMB-003 du Canada.

Australia and New Zealand Class A statement

Attention: This is a Class A product. In a domestic environment this product may cause radio interference in which case the user may be required to take adequate measures.

United Kingdom telecommunications safety requirement

Notice to Customers

This apparatus is approved under approval number NS/G/1234/J/100003 for indirect connection to public telecommunication systems in the United Kingdom.

European Union EMC Directive conformance statement

This product is in conformity with the protection requirements of EU Council Directive 89/336/EEC on the approximation of the laws of the Member States relating to electromagnetic compatibility. IBM cannot accept responsibility for any failure to satisfy the protection requirements resulting from a nonrecommended modification of the product, including the fitting of non-IBM option cards.

This product has been tested and found to comply with the limits for Class A Information Technology Equipment according to CISPR 22/European Standard EN 55022. The limits for Class A equipment were derived for commercial and industrial environments to provide reasonable protection against interference with licensed communication equipment.

Attention: This is a Class A product. In a domestic environment this product may cause radio interference in which case the user may be required to take adequate measures.

Taiwan electrical emission statement

警告使用者：
這是甲類的資訊產品，在
居住的環境中使用時，可
能會造成射頻干擾，在這
種情況下，使用者會被要
求採取某些適當的對策。

Japanese Voluntary Control Council for Interference (VCCI) statement

この装置は、情報処理装置等電波障害自主規制協議会（VCCI）の基準に基づくクラスA情報技術装置です。この装置を家庭環境で使用すると電波妨害を引き起こすことがあります。この場合には使用者が適切な対策を講ずるよう要求されることがあります。

Power cords

For your safety, IBM provides a power cord with a grounded attachment plug to use with this IBM product. To avoid electrical shock, always use the power cord and plug with a properly grounded outlet.

IBM power cords used in the United States and Canada are listed by Underwriter's Laboratories (UL) and certified by the Canadian Standards Association (CSA).

For units intended to be operated at 115 volts: Use a UL-listed and CSA-certified cord set consisting of a minimum 18 AWG, Type SVT or SJT, three-conductor cord, a maximum of 15 feet in length and a parallel blade, grounding-type attachment plug rated 15 amperes, 125 volts.

For units intended to be operated at 230 volts (U.S. use): Use a UL-listed and CSA-certified cord set consisting of a minimum 18 AWG, Type SVT or SJT, three-conductor cord, a maximum of 15 feet in length and a tandem blade, grounding-type attachment plug rated 15 amperes, 250 volts.

For units intended to be operated at 230 volts (outside the U.S.): Use a cord set with a grounding-type attachment plug. The cord set should have the appropriate safety approvals for the country in which the equipment will be installed.

IBM power cords for a specific country or region are usually available only in that country or region.

IBM power cord part number	Used in these countries and regions
13F9940	Argentina, Australia, China (PRC), New Zealand, Papua New Guinea, Paraguay, Uruguay, Western Samoa
13F9979	Afghanistan, Algeria, Andorra, Angola, Austria, Belgium, Benin, Bulgaria, Burkina Faso, Burundi, Cameroon, Central African Rep., Chad, China (Macau S.A.R.), Czech Republic, Egypt, Finland, France, French Guiana, Germany, Greece, Guinea, Hungary, Iceland, Indonesia, Iran, Ivory Coast, Jordan, Lebanon, Luxembourg, Malagasy, Mali, Martinique, Mauritania, Mauritius, Monaco, Morocco, Mozambique, Netherlands, New Caledonia, Niger, Norway, Poland, Portugal, Romania, Senegal, Slovakia, Spain, Sudan, Sweden, Syria, Togo, Tunisia, Turkey, former USSR, Vietnam, former Yugoslavia, Zaire, Zimbabwe
13F9997	Denmark
14F0015	Bangladesh, Burma, Pakistan, South Africa, Sri Lanka
14F0033	Antigua, Bahrain, Brunei, Channel Islands, China (Hong Kong S.A.R.), Cyprus, Dubai, Fiji, Ghana, India, Iraq, Ireland, Kenya, Kuwait, Malawi, Malaysia, Malta, Nepal, Nigeria, Polynesia, Qatar, Sierra Leone, Singapore, Tanzania, Uganda, United Kingdom, Yemen, Zambia
14F0051	Liechtenstein, Switzerland
14F0069	Chile, Ethiopia, Italy, Libya, Somalia
14F0087	Israel
1838574	Thailand

IBM power cord part number	Used in these countries and regions
6952301	Bahamas, Barbados, Bermuda, Bolivia, Brazil, Canada, Cayman Islands, Colombia, Costa Rica, Dominican Republic, Ecuador, El Salvador, Guatemala, Guyana, Haiti, Honduras, Jamaica, Japan, Korea (South), Liberia, Mexico, Netherlands Antilles, Nicaragua, Panama, Peru, Philippines, Saudi Arabia, Suriname, Taiwan, Trinidad (West Indies), United States of America, Venezuela

Index

A

- AC power LED 8
- acoustical noise emissions 3
- adapter, specifications 3
- advanced setup 15
- attention notices 1
- availability features 5

C

- cache control 15
- caution statements 1
- CD-ROM drive
 - activity LED 8
 - eject button 8
 - specifications 3
- Class A electronic emission notice 39
- configuration
 - Configuration/Setup Utility 13
 - Ethernet 22
 - LSI Logic Configuration Utility 13
 - ServerRAID programs 13
 - ServerGuide Setup and Installation CD 13
 - with ServerGuide 18
- Configuration/Setup Utility program 13
- controls and indicators 8
- cooling 3
- core chipset control 15

D

- danger statements 1
- data rate, Ethernet 22
- DC power LED 8
- device driver, update 6
- diskette drive
 - activity LED 8
 - specifications 3
- diskette, eject button 8

E

- eject button
 - CD-ROM 8
 - diskette 8
- electrical input 3
- electrical safety information viii
- electronic emission Class A notice 39
- environment 3
- Ethernet
 - activity LED 8
 - configuring 22
 - high performance modes 22
 - integrated on system board 22
 - link status LED 8
 - modes 22
 - teaming 22

- Ethernet controller, configuring 22

F

- FCC Class A notice 39
- features
 - reliability, availability, and serviceability 5
 - server 3, 4
 - ServerGuide 17
- firmware, update 6
- formatting a hard disk using LSI Logic
 - Configuration 22

H

- hard disk drive
 - activity LED 8, 9
 - status LED 9
- heat output 3
- hot-swap drive, specifications 3

I

- IBM Configuration/Setup Utility program
 - menu choices 14
 - starting 13
 - using 13
- IBM Director 6
- important notices 1
- information label 1

L

- LEDs
 - AC power 8
 - DC power 8
 - hard disk drive activity 9
 - hard disk drive status 9
- LSI Logic Configuration Utility 13
 - description 21
 - formatting a hard disk 22
 - starting 21

M

- memory specifications 3
- microprocessor
 - cache 15
 - specifications 3
- modes, Ethernet 22

N

- NOS installation
 - with ServerGuide 19
 - without ServerGuide 20
- notes 1

notes, important 38
notices
 electronic emission 39
 FCC, Class A 39
notices and statements 1

P

password
 forgotten power-on 16
 setting 14
 using 16
PCI configuration 15
PCI expansion slots 3
power supply specifications 3
power switch 9
power-control button 9
power-control-button shield 9, 10
power-on LED 9
processor control 15

R

RAS
 reliability, availability, and serviceability 5
RAS features 5
related publications 2
reliability features 5
Remote Supervisor Adapter, configuration 13

S

safety information
 electrical vi, viii
 laser vii
 lifting vii
ServeRAID Manager
 description 20
 overview 20
 startable-CD mode 21
ServeRAID programs 13
ServerGuide
 CDs 13
 features 17
 NOS installation 19
 setting up multiple servers 20
 Setup and Installation CD 13
 using 17
serviceability features 5

setting up multiple servers 20
setup
 advanced 15
 with ServerGuide 18
shield, power-control button 10
size 3
SMP 1
specifications 3
startable-CD mode 21
starting
 LSI Logic Configuration Utility 21
 the server 10
statements and notices 1
symmetric multiprocessing 1
system error LED 9
systems management 6

T

temperature 3
trademarks 38
turning on the server 10

U

United States electronic emission Class A notice 39
United States FCC Class A notice 39
update device drivers and firmware 6
using
 IBM Configuration/Setup Utility program 13
 passwords 14, 16
utility
 LSI Logic Configuration 21
 ServeRAID Manager 20

V

video 3
video controller 3

W

Web site
 IBM server products 1
 ServerGuide 17
weight 3
World Wide Web 1



Part Number: 59P2104

Printed in the United States of America.

59P2104

