

This manual is for reference and historical purposes, all rights reserved.

This page is copyright© by M. Butkus, NJ.

This page may not be sold or distributed without the expressed permission of the producer

I have no connection with any camera company

On-line camera manual library

This is the full text and images from the manual. This may take 3 full minutes for the PDF file to download.

If you find this manual useful, how about a donation of \$3 to: M. Butkus, 29 Lake Ave., High Bridge, NJ 08829-1701 and send your e-mail address so I can thank you. Most other places would charge you \$7.50 for a electronic copy or \$18.00 for a hard to read Xerox copy.

This will allow me to continue to buy new manuals and pay their shipping costs.

It'll make you feel better, won't it?

**If you use Pay Pal or wish to use your credit card,
click on the secure site on my main page.**

This manual is for reference and historical purposes, all rights reserved.

This page is copyright© by M. Butkus, NJ.

This page may not be sold or distributed without the expressed permission of the producer

I have no connection with any camera company

On-line camera manual library

This is the full text and images from the manual. This may take 3 full minutes for the PDF file to download.

If you find this manual useful, how about a donation of \$3 to: M. Butkus, 29 Lake Ave., High Bridge, NJ 08829-1701 and send your e-mail address so I can thank you. Most other places would charge you \$7.50 for a electronic copy or \$18.00 for a hard to read Xerox copy.

This will allow me to continue to buy new manuals and pay their shipping costs.

It'll make you feel better, won't it?

**If you use Pay Pal or wish to use your credit card,
click on the secure site on my main page.**

H A S S E L B L A D[®]



Instruction manual

2000FC

Hasselblad 2000FC

The Hasselblad 2000FC is a 2 1/4 x 2 1/4 single-lens reflex camera featuring lens, magazine, viewfinder and shutter using screen interchangeability. Its unique design gives you a choice of shutter options, focal plane or leaf, depending on your requirements.

The '2000' in the designation 2000FC stands for the fastest shutter speed, 1/2000 s, the 'F' stands for focal plane shutter and the 'C' stands for the (Synchro-) Compur leaf shutter, so you can work with the camera's own focal plane shutter or with the leaf shutter built into lenses made for the Hasselblad 500C, 500C/M, 500EL and 500C/M since 1957.

Lenses especially designed for the Hasselblad 2000FC will be referred to as F lenses in this instruction manual. Lenses with Synchro-Compur leaf shutters will be referred to as C lenses.

F lenses, which have no built-in shutter, can only be used with the camera's focal plane shutter. But when a C lens is attached to the Hasselblad 2000FC, you can either use the camera's focal plane shutter or the leaf shutter in the lens.

The focal plane shutter serves as a blind when the leaf shutter is the shutter of choice. The leaf shutter provides the advantage of flash synchronization at all shutter speeds down to 1/500 s.

The Hasselblad 2000FC has an electronically timed focal plane shutter with X synchronization at 1/90 s and slower. Electronic shutter timing makes for extremely accurate shutter operation.

A choice of mirror return is another feature of the Hasselblad 2000FC. The photographer can select either a program producing instant mirror return or a program in which the mirror remains in its raised position until the film is advanced after exposure.

The mirror return can also be raised position for special purpose applications. The program for multiple exposures on the same frame has been included in the instruction manual for the Hasselblad 2000FC.

This manual describes the various camera operation and describe some of the ways to utilize the special features.

It is recommended that you thoroughly study a new or unfamiliar camera's instruction manual before the camera is put to use. The few minutes spent this way can save you a great deal of trouble later on.

2000FC with F lens

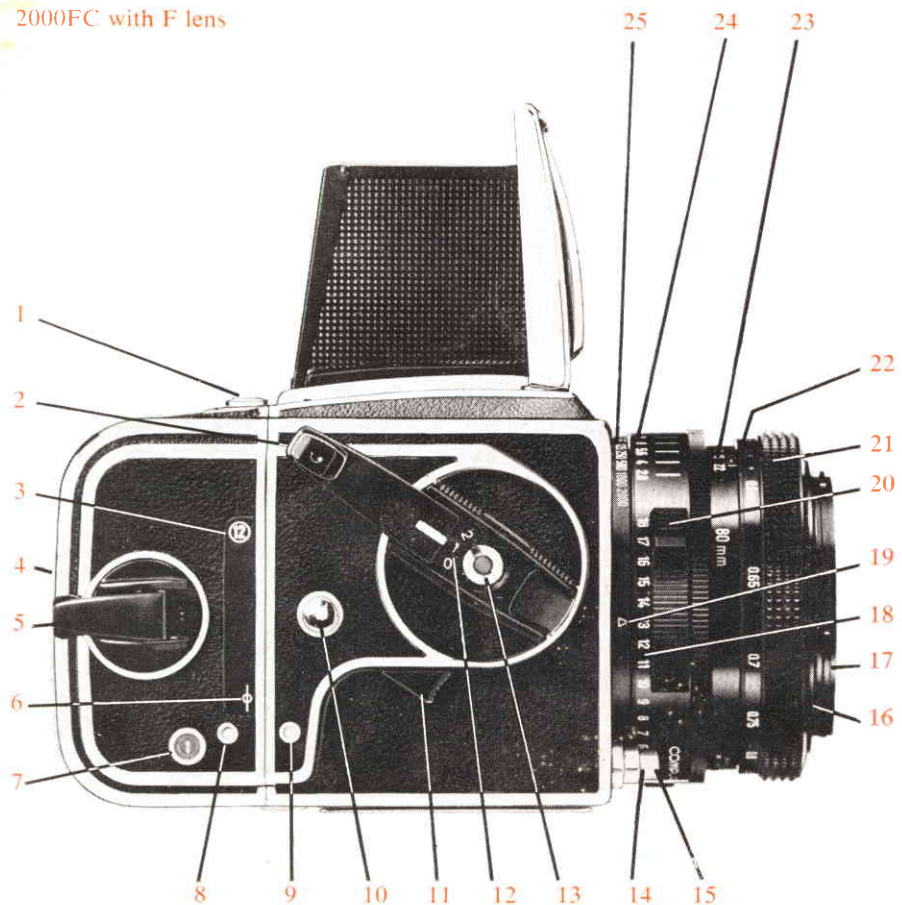

1. Magazine release catch
2. Folding crank for film advance and shutter cocking
3. Magazine designation
4. Film indicator
5. Film winding crank
6. Film plane marking
7. Frame counter window
8. Film advance indicator window
9. Shutter cocking indicator window
10. Strap lug
11. Pre-release latch
12. Mirror program settings
13. Mirror program disc
14. Shutter release button
15. Cable release socket
16. External bayonet accessory mount
17. Internal bayonet accessory mount
18. Exposure value scale
19. Exposure value index (red)
20. Button for cross-coupling of shutter and diaphragm
21. Focusing ring
22. Distance scale
23. Depth-of-field scale
24. Aperture ring with aperture scale
25. Shutter speed ring with shutter speed scale

26. Catch for focusing hood and fine-focus magnifier
27. Fine-focus magnifier
28. Focusing hood
29. Index for shutter speeds
30. Index for aperture scale
31. Index for distance scale
32. Synchronization terminal for focal plane shutter
33. Shutter speed prong
34. Depth-of-field preview catch
35. Fixed grip ring
36. Projecting aperture grip
37. Lens lock release button
38. Lever for locking shutter speed ring
39. Battery compartment with battery cassette
40. Tripod plate and $\frac{3}{8}$ " tripod socket
41. Accessory rail
42. Strap lug
43. Magazine support catches
44. Roll holder key
45. Film consumption indicator
46. Magazine slide
47. Focusing screen

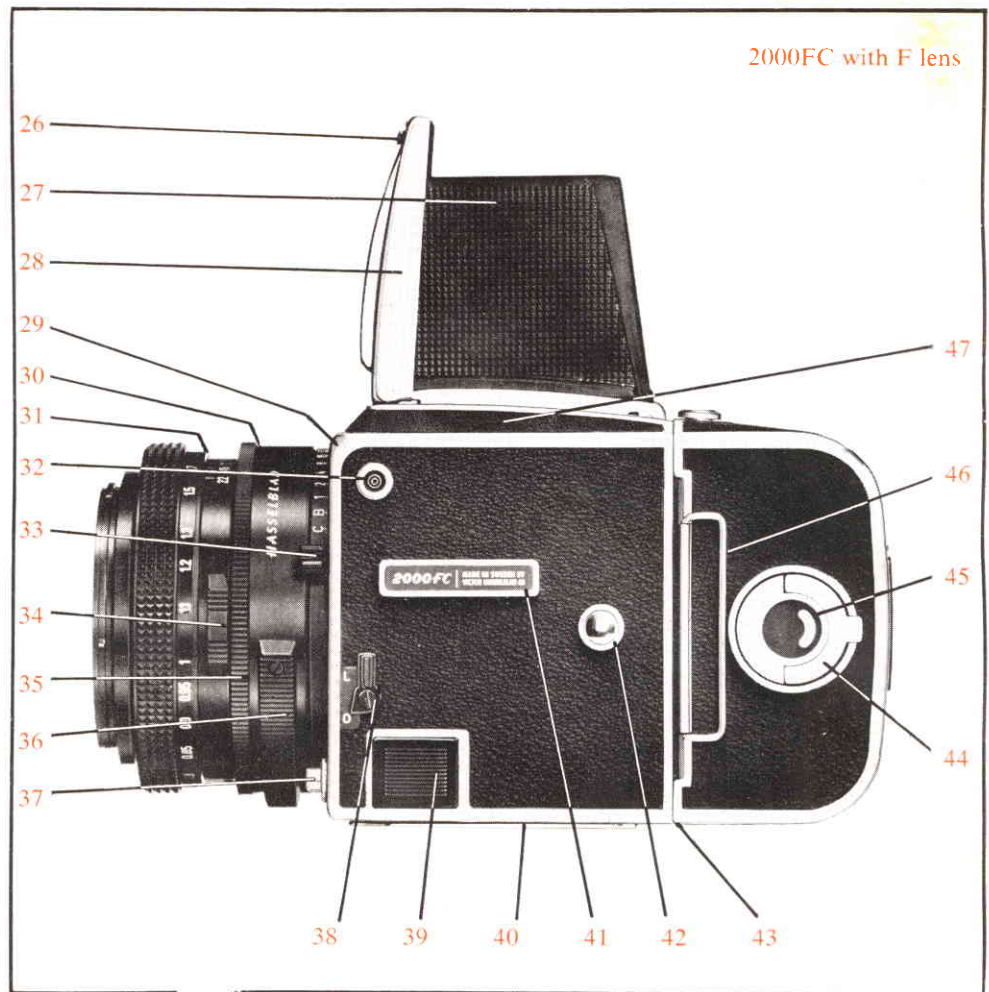

Fig. 2

Open the focusing hood (28) by sliding the catch (26) to the right.

The magazine slide (46) must be removed prior to exposure. A number should show in the frame counter window (7), and the indicator windows (8 and 9) should display white signals.

Button (20) for cross-coupling of shutter and diaphragm.

Folding crank (2) which is wound one full turn to advance the film and cock the shutter.

Mirror program disc (13). To be pressed at the start of shutter cocking with the crank (2) when intentional double exposures are desired. Rotate the disc with a coin to select a mirror action program.

Pre-release operation using the latch (11) cuts camera reaction time to a minimum. Only actual shutter release then takes place when the camera is triggered.

The camera is released when the release latch (14) is pressed. The button contains a cable release socket.

CAMERA OPERATION IN BRIEF

The fine-focus magnifier (27) pops up when the catch (26) on an open focusing hood is again slid to the right.

The focusing hood (28) can be removed. Just slide it back off the camera body after first removing the film magazine. The focusing screen (47) is also interchangeable.

Aperture, shutter speed and distance are set against the indexes (29, 30, 31).

Focus by rotating the focusing ring (21).

Synchronization terminal (32). X synchronization at 1/90 s or longer.

Accessory rail (41) for e. g. a sports viewfinder, spirit level or adjustable flash shoe.

The depth-of-field preview catch (34) can be locked in the stopped down position.

Lever (38) for locking the shutter speed ring.

Battery cassette for 6 V battery.

The lens can be removed once the lens lock release button (37) is pressed. *It should never be removed unless the camera is cocked.*

Bayonet accessory mounts for supplementary lenses, filters and lens shades.

Tripod plate (40) with $\frac{3}{8}$ " tripod socket.

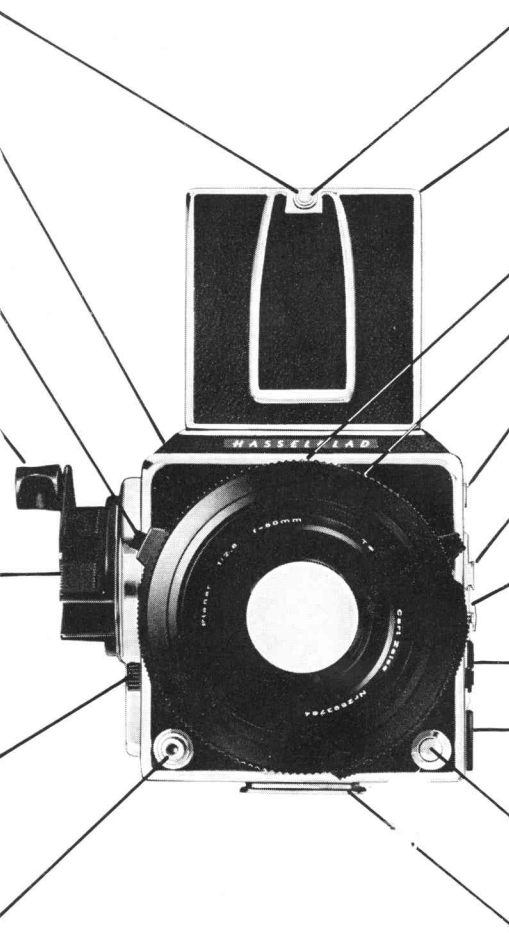
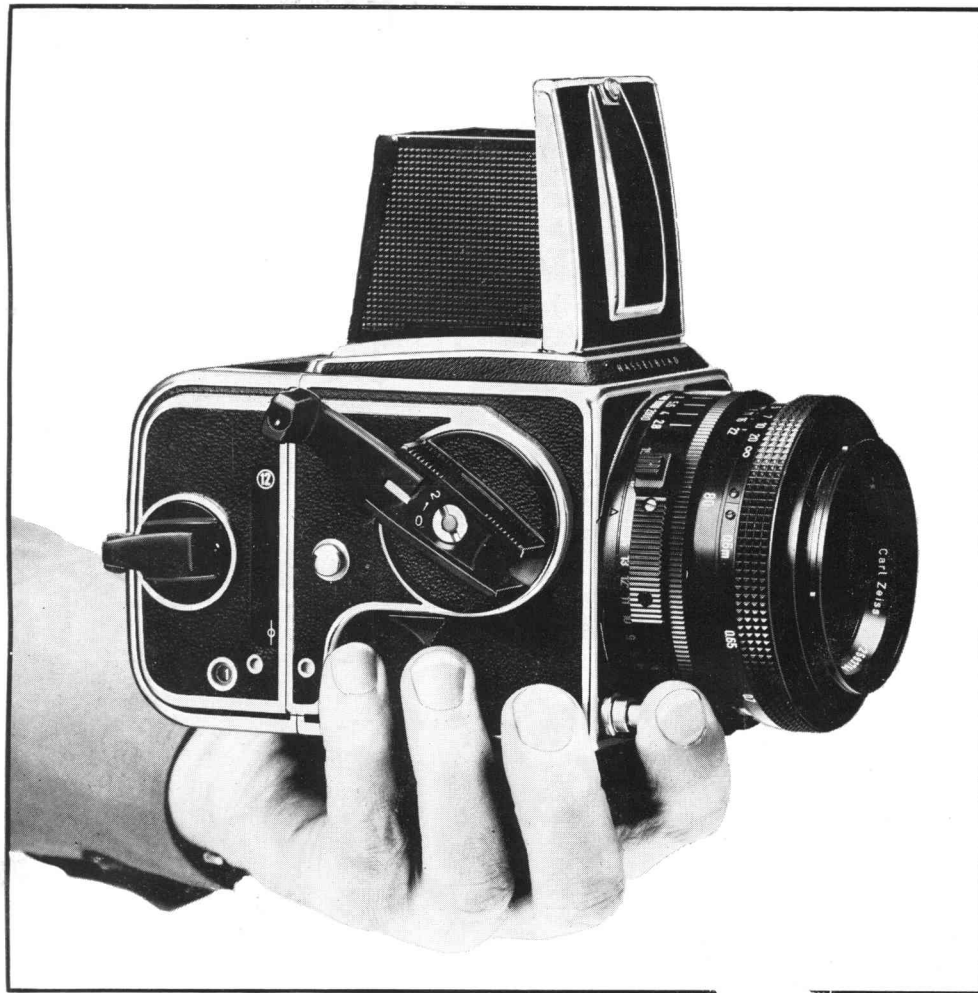

Fig. 3

Lens	F lens plus focal plane shutter	C lens plus focal plane shutter	C lens plus leaf shutter
Shutter	Focal plane	Focal plane	Leaf shutter
Shutter settings	—	Leaf shutter set at B. Leaf shutter's synchronization selector set at X.	Camera's shutter speed ring locked in position C.
Shutter speeds	Speeds: B, 1—1/2000 s set on the camera's shutter speed ring (25).	Speeds: B, 1—1/2000 s set on the camera's shutter speed ring (25).	Speeds: B, 1—1/500 s set on the shutter speed ring of the lens.
Flash synchronization	The flash contact is connected to the camera's flash terminal (32). Shutter speeds of 1/90 s or longer set on the camera's shutter speed ring (25).	The flash contact is connected to the camera's flash terminal (32). Shutter speeds of 1/90 s or longer set on the camera's shutter speed ring (25).	The flash contact is connected to the flash terminal of the lens. Optional shutter speed ranging from B, 1—1/500 s set on the shutter speed ring of the lens.

Fig. 4



Left-hand grip

Fig. 5 shows the best way to hold a Hasselblad 2000FC when photographing. Cradle the camera in your *left* hand with your left index finger resting lightly on the release button.

This leaves your right hand free for other operations such as film winding, shutter cocking, focusing etc. Make it a habit to use the left-hand grip when holding your camera.

Focusing hood (Fig. 6 and 7)

The focusing hood (28) opens automatically when the catch (26) is slid to the right. The hood's fine-focus magnifier is used for critical focusing. It pops up when the catch (26) is again slid to the right with the hood open. To close the hood, first flip the magnifier down until it clicks into place. Then fold the hood walls down over the focusing screen, side walls first, followed by the rear wall and finally the lid.

Changing viewfinders

1. Remove the film magazine.
2. Slide the finder back out of the grooves (only slight resistance should be felt).
3. Slide another finder forward into the grooves.
4. Reattach a film magazine.

Fig. 6

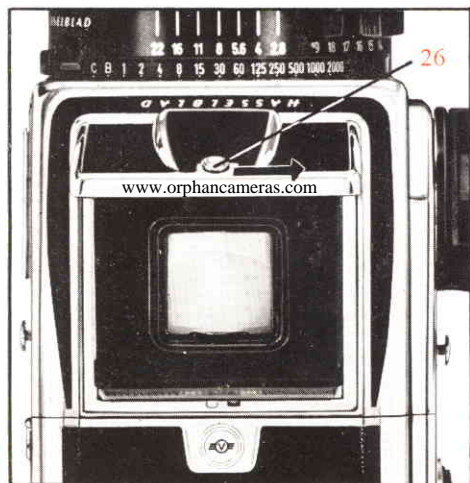

Fig. 7

LENSES

Introduction

All the lenses made for the Hasselblad 500C, 500C/M, 500EL and 500EL/M (C lenses in which the C stands for the built-in Synchro-Compur leaf shutters) also fit the Hasselblad 2000FC. However, a series of lenses (F lenses) have been especially designed for the 2000FC.

F lenses (Fig. 8)

Lenses for the Hasselblad 2000FC will be referred to as F lenses in this instruction manual (the 'F' stands for the focal plane shutter, but will not be found on the lenses themselves). Since F lenses have no built-in shutters, they can not be used with the Hasselblad 500C, 500C/M, 500EL or 500EL/M.

F lenses have diaphragms which automatically stop down to the preselected f/stop when the camera is triggered and reopen to the maximum aperture after concluded exposure. However, the depth-of-field yielded by the preselected f/stop can be previewed using the depth-of-field preview catch (34).

C lenses (Fig. 9)

Lenses made for the Hasselblad 500C, 500C/M, 500EL and 500EL/M will be referred to as C lenses in this instruction manual. (However, this designation will not be found on the lenses themselves). C lenses can even be used with the Hasselblad 2000FC.

Paragraphs printed in bold face indicate the use of C-lenses.

Fig. 8



Fig. 9

Fig. 10

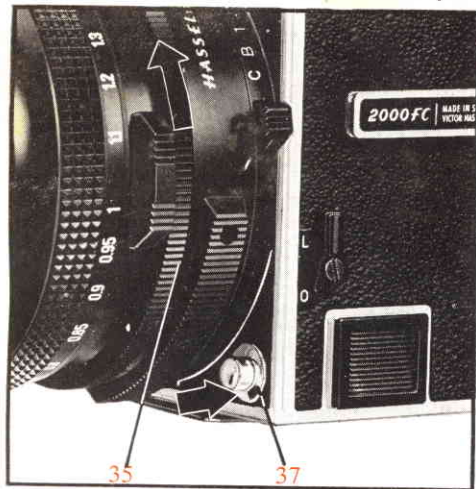

The C lenses have diaphragm which automatically stop down to the preselected f/stop when the camera is triggered. They also have built-in Synchro-Compur leaf shutters fully synchronized at all shutter speeds (1-1/500 s).

The shutter is cocked and the diaphragm reopens to its maximum aperture during the film advance sequence.

CHANGING LENSES

F lenses

Lens removal (Fig. 10)

Make sure the shutter is cocked (white signal in the shutter cocking indicator window 9).

Hold the lens by the fixed grip ring (35) but never press on the button for cross-coupling of shutter and diaphragm (20) during lens removal because this could cause damage to the cross-coupling mechanism. Press the lens lock release button (37) with your left index finger. Then remove the lens by turning it counter-clockwise one-fifth of a revolution using gentle pressure only.

Note: If the lens refuses to budge, the camera is in the pre-release mode. Restore it to the normal mode by depressing the slotted mirror program disc (13) and rotating the film advance crank (2) a full turn.

Lens attachment (Fig. 11)

Make sure the shutter is cocked and not in the pre-release mode (see p. 21). Otherwise the lens mechanism could be dam-

Fig. 11

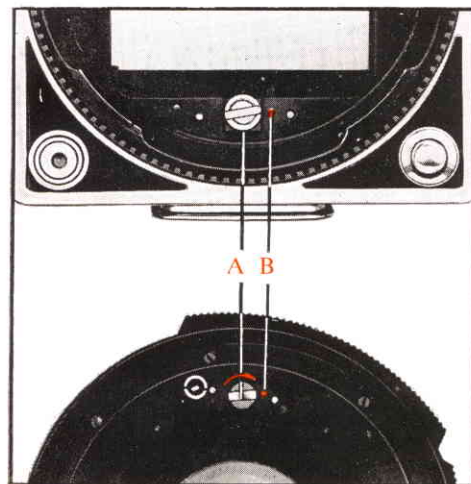
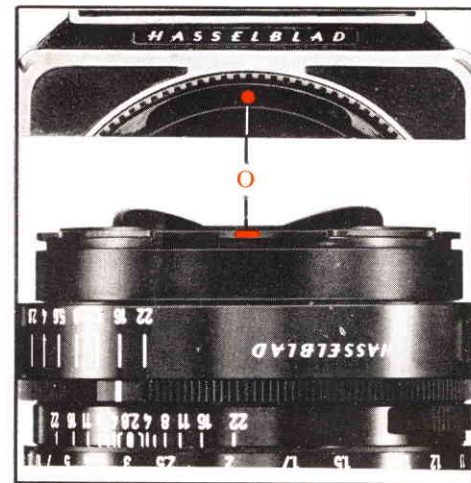

Fig. 12

aged when the lens is attached. Also make sure the diaphragm is cocked. The slot (A) on the head of the cocking shaft should point to the red dot (B). (Also see 'Diaphragm cocking' for details on the cocking of released lenses.)

Align the red triangle at the rear of the lens with the red dot (O) on the camera lens mount (Fig. 11). Then carefully insert the lens into the camera lens mount and rotate the lens *clockwise* one-fifth of turn—using *gentle* pressure—until the lens locks in place with an audible click.

Never press on the button for cross coupling of shutter and diaphragm (20) while changing lenses, since this could cause damage to the cross-coupling mechanism.

C lenses

C lenses are attached and removed in the same manner as F lenses.

Diaphragm cocking (Fig. 12)

F lenses

When an F lens is attached to the camera, the diaphragm mechanism in the lens is automatically cocked at the same time as the film is advanced with the folding crank (2).

Make sure the diaphragm is cocked before a lens is attached to the camera. The diaphragm is cocked when the slot (A) on the head of the cocking shaft points to the red dot (B). If the lens has been off the camera and the diaphragm inadvertently released the diaphragm must be recocked before the lens can be reattached to the camera.

The diaphragm is cocked by rotating the

cocking shaft *clockwise*, using e.g. a coin of suitable size in the shaft slot (A), slightly less than one full turn until the shaft stops in the cocked position. (This procedure should be carried out with great caution so that the coin or any other device used to cock the shaft does not skip out of the slot and damages the rear lens element.)

Note: The same cocking procedure is also employed for extension tubes.

C lenses

The shutter and diaphragm of C lenses are cocked in the same manner as in F lenses.

BATTERY (Fig. 13)

The electronics responsible for shutter timing are powered by a 6 V battery (e.g. PX-28).

Batteries marked with a lower voltage must not be used.

Loading or replacing battery

- Pull out the battery cassette.
- Insert the battery with the (+) terminal facing the (+) marking in the cassette.
- To avoid inserting a battery in a mechanically triggered camera, depress the slotted mirror program disc (13) and rotate the film advance crank (2) a full turn.
(If a battery is inserted in a mechanically triggered camera, the life of the battery will be drastically reduced.)
- Reinsert the cassette containing the battery in the camera.

Fig. 13

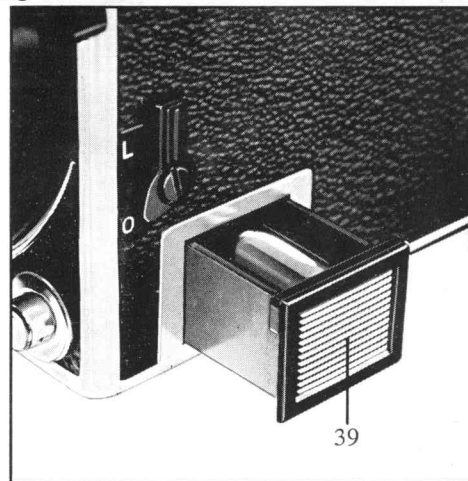

A fresh battery of the above type should last for at least 20,000 exposures. Check regularly to ensure that the battery is not leaking. To prevent the leakage which sometimes occurs after protracted storage, change the battery at least once a year.

Fig. 14

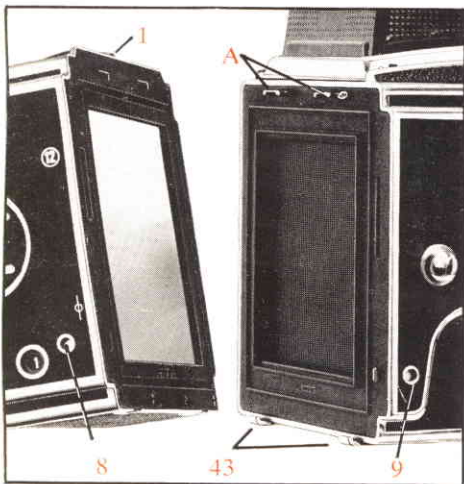
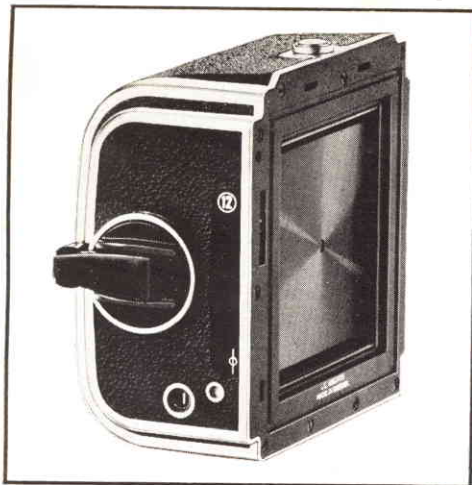

Fig. 15

FILM MAGAZINES

All the film magazines in the Hasselblad system fit the Hasselblad 2000FC *except the Magazine 80 for Polaroid film whose projecting glass plate will destroy the shutter curtains in the camera.*

Changing magazines (Fig. 15)

Make sure the indicator windows (8 and 9) display white signals before a magazine is switched.

The magazine slide (46) *must* be inserted before the magazine can be removed from the camera.

Slide the magazine release catch (1) to the right, swing down the magazine and lift it off the camera's two support catches (43). The magazine slide (46) protects the film from fogging when the magazine is off the camera.

A magazine is attached to the camera as follows:

Hook the magazine securely onto the two magazine support catches (43) and pivot the magazine up against the upper locking latches (A) while simultaneously sliding the magazine release catch (1) to the right. Release the release catch. *Then slide it back to the left for secure locking.*

Pull out the magazine slide. Your first exposure can now be made.

Note: A magazine can only be removed from the camera when the magazine slide is in place. No exposure can be made when the slide is in an attached magazine.

Fig. 16

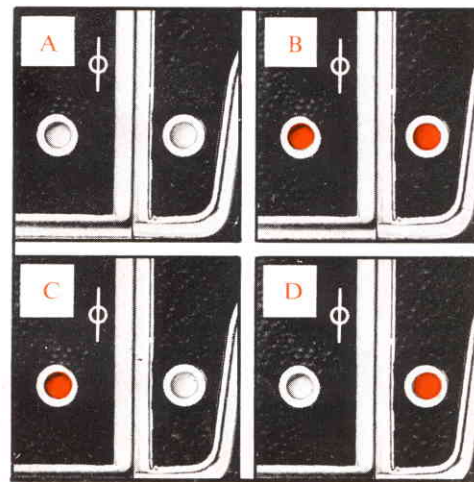
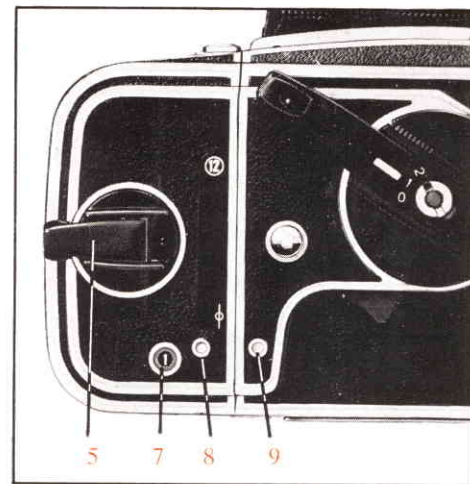

Fig. 17

Indicator signals (Fig. 16 and 17)

The camera body and film magazine have indicator windows (8 and 9) whose displays are affected by the film advance. The following signals can be displayed in the indicator windows:

A. Both windows white: Camera ready for exposure.

B. Both windows red: An exposure has been made but the film has not been advanced nor the shutter cocked. Advance the film and cock the shutter with the crank (2).

C. Film advance indicator window (8) red and shutter cocking indicator window (9) white: Magazine attached to a cocked camera with the exposed frame un-advanced. Remove the magazine, trigger the camera, replace the magazine and advance the film.

D. Film advance indicator window (8) white and shutter cocking indicator window (9) red: Magazine with advanced film attached to uncocked camera. Depress the mirror program disc (13), including the red center button, and wind the crank (2) one full turn. The disc (13) only has to be kept depressed during the initial phase of crank revolution.

General rule: Make sure the signals in the indicator windows (8 and 9) display the *same* color before attaching a magazine.

Miscellaneous

The film winding crank (5) is only blocked at frame 1. So you can wind film onto the magazine take-up spool any time after frame 1 is exposed.

The frame counter (7) is automatically reset when the roll holder key (44) is removed.

The center of the roll holder key (44) features a film consumption indicator (45) which is white when the film supply spool is full but which gradually turns red as each frame is advanced. A completely red film consumption indicator means that the final frame on a roll has been exposed or that there is no film in the magazine. The ASA or DIN film speed (B) can be set on the film indicator (4).

Settings are made by flipping down the indicator lid (4) and rotating the serrated ring. There is space behind the lid (4) for insertion of a film box tab as a reminder.

Fig. 18

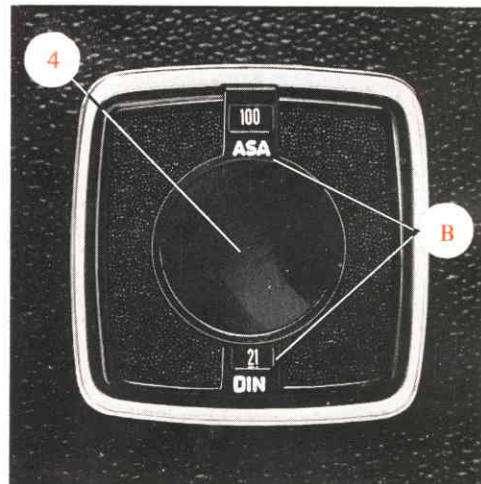
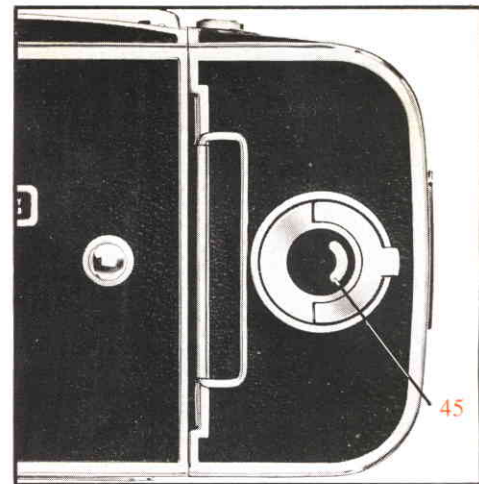

Fig. 19

Fig. 20



Fig. 21

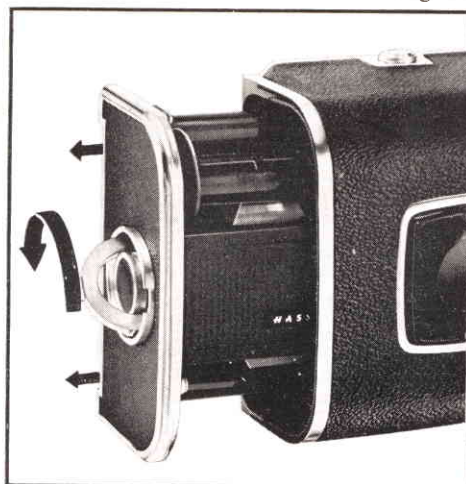
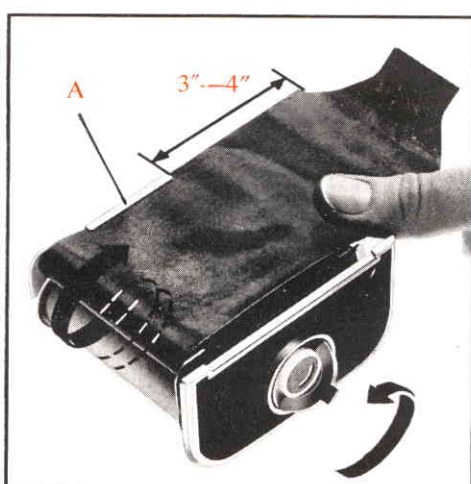
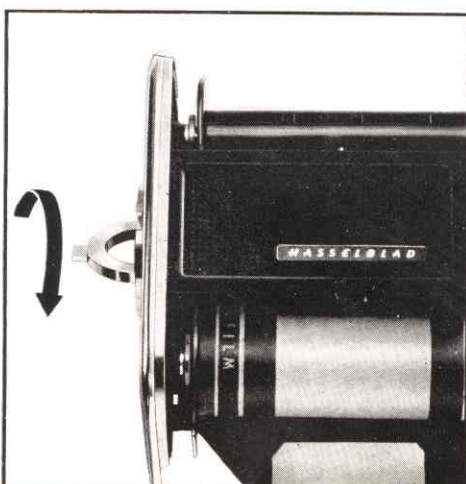
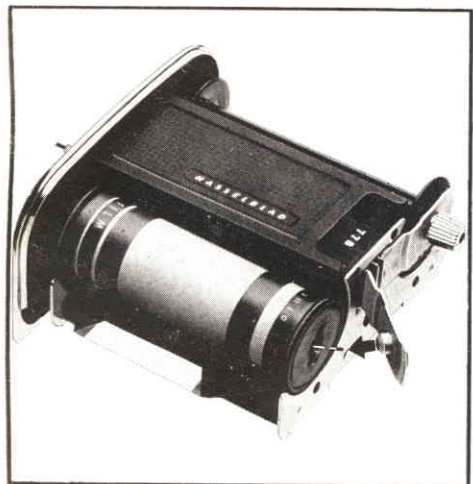
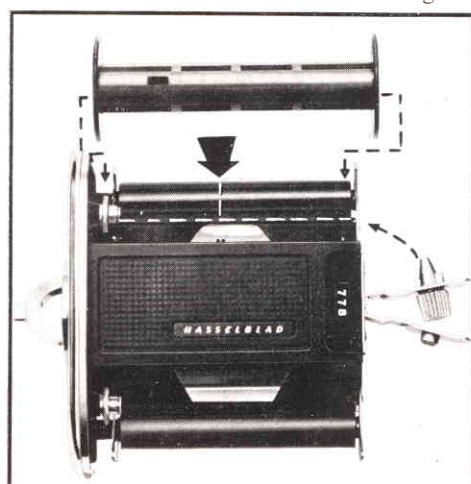

Fig. 22



Loading of Magazine A12

Fig. 20. Fold out the magazine's roll holder key.

Fig. 21. Turn the roll holder key *counter-clockwise*. Pull the roll holder out of the magazine.

Fig. 22. Flip up both spool clips. Insert an empty take-up spool onto the prong on the take-up side and flip down the take-up clip (with the knurled knob) onto the spool.

Fig. 23. Insert a roll of film onto the prong on the film side as shown in the photograph and flip down the film clip (with the red arrow) onto the film spool. Make sure the entire paper band around the film is removed first.

Fig. 24. Turn the roll film holder *clockwise* so that the film clamp (A, Fig. 25) opens.

Fig. 25. Pull out 3—4 inches of paper backing and guide the backing under the film clamp (A). Turn the roll holder key *counter-clockwise* so that the paper backing is held down by the film clamp (A).

Fig. 26. Insert the tongue of the paper backing into a take-up spool slit.

Fig. 27. Roll the paper backing onto the take-up spool, turning the clip knob *clockwise*, until the arrow on the paper backing is aligned with the arrow on the film clip.

Fig. 28. Carefully reinsert the roll holder into the magazine and lock it in place by turning the roll holder key (44) *clockwise*.

Fig. 29. Make sure the magazine slide (46)

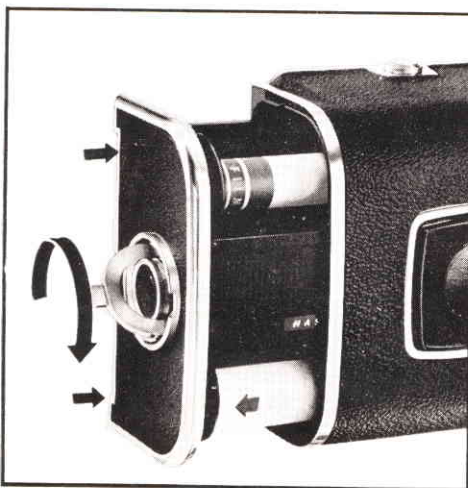
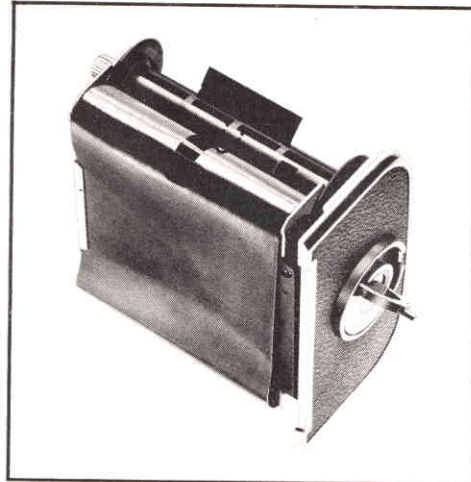

Fig. 28

Fig. 27

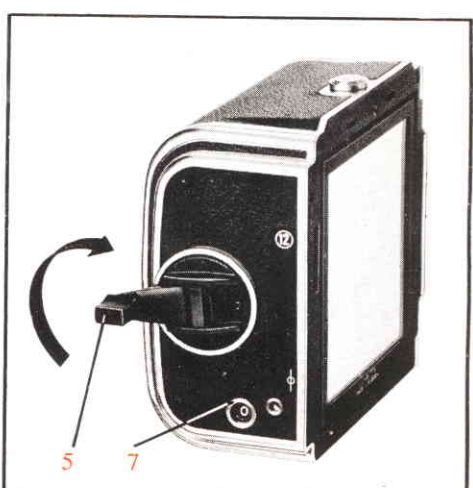
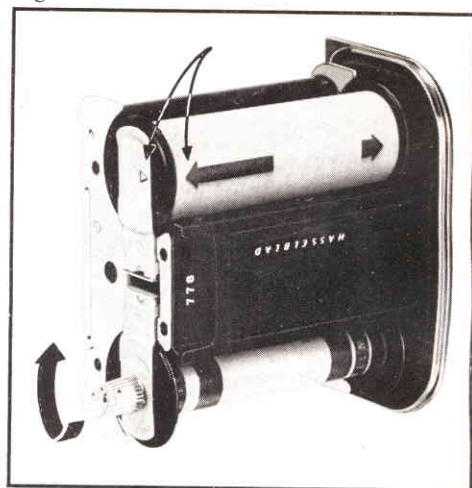

Fig. 29