



This manual is for reference and historical purposes, all rights reserved.

This page is copyright© by M. Butkus, NJ.

This page may not be sold or distributed without the expressed permission of the producer

I have no connection with any camera company

On-line camera manual library

This is the full text and images from the manual. This may take 3 full minutes for the PDF file to download.

If you find this manual useful, how about a donation of \$3 to: M. Butkus, 29 Lake Ave., High Bridge, NJ 08829-1701 and send your e-mail address so I can thank you. Most other places would charge you \$7.50 for a electronic copy or \$18.00 for a hard to read Xerox copy.

This will allow me to continue to buy new manuals and pay their shipping costs.

It'll make you feel better, won't it?

**If you use Pay Pal or wish to use your credit card,
click on the secure site on my main page.**

HASSELBLAD®

2003FCW
2000FCW



INSTRUCTION MANUAL

Hasselblad 2003FCW Instruction Manual

This instruction also applies to the 2000FCW

Page

2	Accessory Chart
3	Introduction
4	Components
6	Front Protective Cover
6	Rear Protective Cover
6	Attaching the Magazine
7	Cocking the shutter
7	The Battery
8	Fitting the Lens
8	Lens Removal
9	Opening the Focusing Hood
9	The Built-in Magnifier
9	Closing the Focusing Hood
10	Focus and Shoot
10	Left Hand Grip
11	Lenses
11	F-lenses
12	Depth-of-field Scale
12	Interlocked Shutter Speed/Aperture
12	Operating the 2003FCW with CF-lenses
13	Setting the Central Shutter Mode
14	Selecting the Focal Plane Shutter Mode
14	Operating the 2003FCW with C-lenses
15	Selecting the Central Shutter Mode
15	Selecting the Focal Plane Shutter Mode

Page

16	The Focal plane Shutter
16	Shutter Protection Mechanism
16	Focal-plane Shutter Speeds
17	Locking the Shutter Speed Ring
17	Pre-releasing the Camera (Mirror up)
18	Flash Photography
18	Flash Connection
19	Change of Focusing Hood or Viewfinder
19	Changing the Magnifier
20	Changing the Focusing Screen
21	The Winding Crank
21	Removing the Crank
21	Fitting the Crank
22	The Mirror Action Modes
22	Selecting a Mirror Action Mode
24	The Film Magazine
24	Removing the Magazine
24	Attaching the Magazine
25	2000FCW: Camera Signal
25	The Magazine Indicator
27	Loading the Magazine
27	Removing Film from the Magazine
28	Load Status and Film Type Indicators
28	Double Exposures
29	Accessory Mounts
30	PME/PME3 Viewfinder Adjustments
32	Camera Care, service and Guarantee

Service and Maintenance

Although extremely reliable and durable, Hasselblad equipment should be serviced and maintained at an authorized Hasselblad Service Centre at regular intervals. Further information on service and maintenance is found in page 32.

Guarantee

Hasselblad cameras are normally covered by an international guarantee for one year. Guarantee conditions and further details are found on page 32.

Copyright © 1988, Victor Hasselblad AB.

All rights reserved. No part of this material may be reproduced, stored in a retrieval system, or transmitted, in any form or by any means, electronic, mechanical, photocopy, recording, or otherwise, without the prior written permission of the Company.

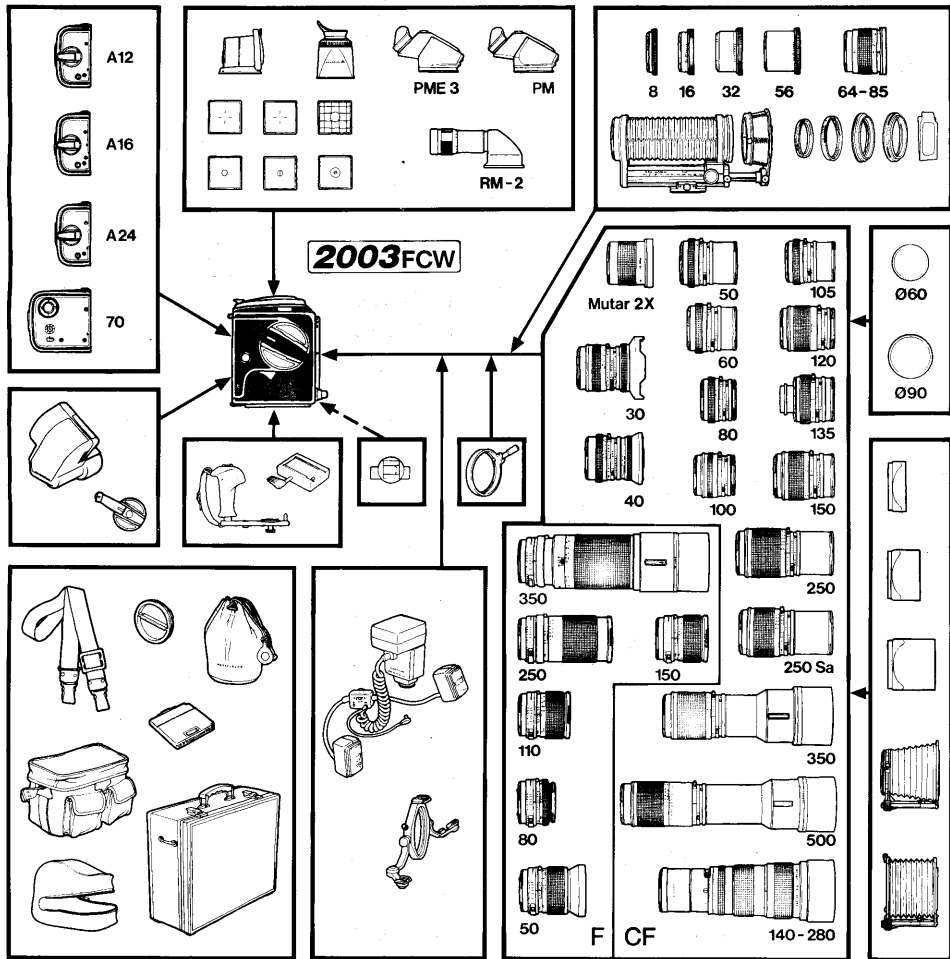

The Hasselblad 2003FCW

The Hasselblad 2003FCW is a single-lens reflex camera featuring lens, magazine, viewfinder and focusing screen interchangeability.

It has the new high brilliancy, high resolution Acute-Matte* focusing screen and is highly improved against internal reflections through the use of the new "Palpas" anti-reflection coating. The grip comfort is also improved by the introduction of the rubber grip-pad on the left hand side of the camera body.

The 2003FCW can be operate manually or fitted with the powerful Hasselblad motor winder, which cycles the camera at 1.3 frames per second.

The 2003FCW also provides a choice of shutter systems—between-the-lens leaf shutters or focal plane shutter—with speeds from 1s to 1/2000s, and allows the use of all Hasselblad lenses manufactured since 1957 as well as the viewfinders, focusing screens, magazines and other accessories in the extensive Hasselblad system. A system that is capable of taking your photography to inner or outer space, and almost anywhere in between.

When used with the between-the-lens (or central) leaf shutters the 2003FCW synchronizes electronic flashes to 1/500s and when used with the camera body's own electronically timed titanium focal plane shutter it synchronizes at 1/90s or slower. At faster speeds the synchronization is disabled to prevent the flash from firing. A mechanical mode allows the C and CF lenses to be used at all their shutter speeds also when the camera's battery is exhausted.

Double exposures can be initiated at the touch of a button which also is used for selecting any of the cameras three mirror programs.

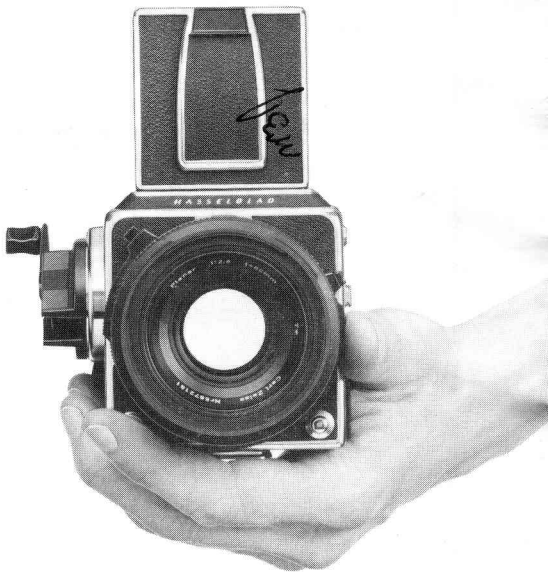

With its outstanding versatility and sophistication the 2003FCW rightfully deserves its place as the flagship of the Hasselblad camera line.

Please take your time to read this instruction manual. It will show you how to set up the 2003FCW from transportation condition to the operating mode without damaging the fragile shutter curtain. It also will enable you to get the very most out of your new camera.

*Acute-Matte designed by MINOLTA

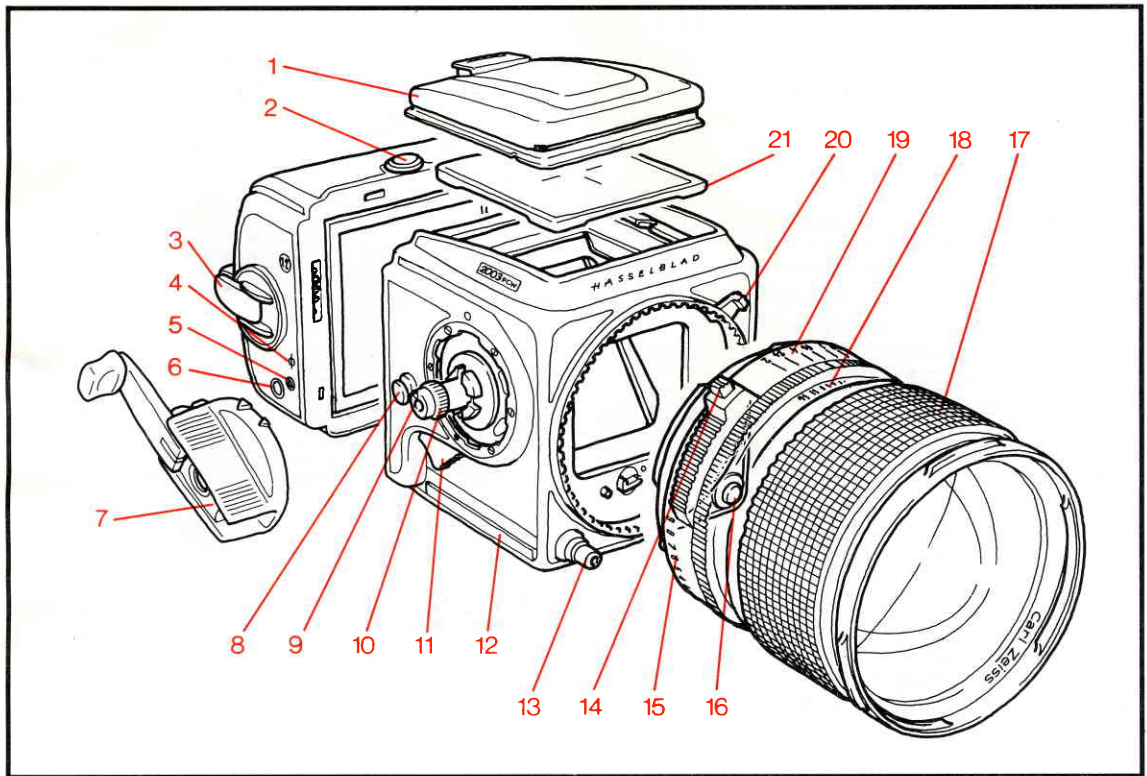

2003FCW Components

- | | | |
|--|-----------------------------|---------------------------------|
| 1 Focusing hood | 10 Mirror mode selector | 19 Aperture selector ring |
| 2 Magazin catch | 11 Pre-release button | 20 Shutter speed selector ring |
| 3 Film winder crank | 12 Rubber grip-pad | 21 Acute-Matte* focusing screen |
| 4 Film plane indicator | 13 Main release button | |
| 5 Magazin status indicator | 14 Interlocking button | |
| 6 Frame counter window | 15 Exposure value scale | |
| 7 Winding crank | 16 Lens lock release button | |
| 8 Strap lug | 17 Lens focusing ring | |
| 9 Mirror mode indicator and double exposure button | 18 Depth-of-field scale | |

NOTE:

The 2003FCW has no status indicator.

* Acute-Matte designed by MINOLTA

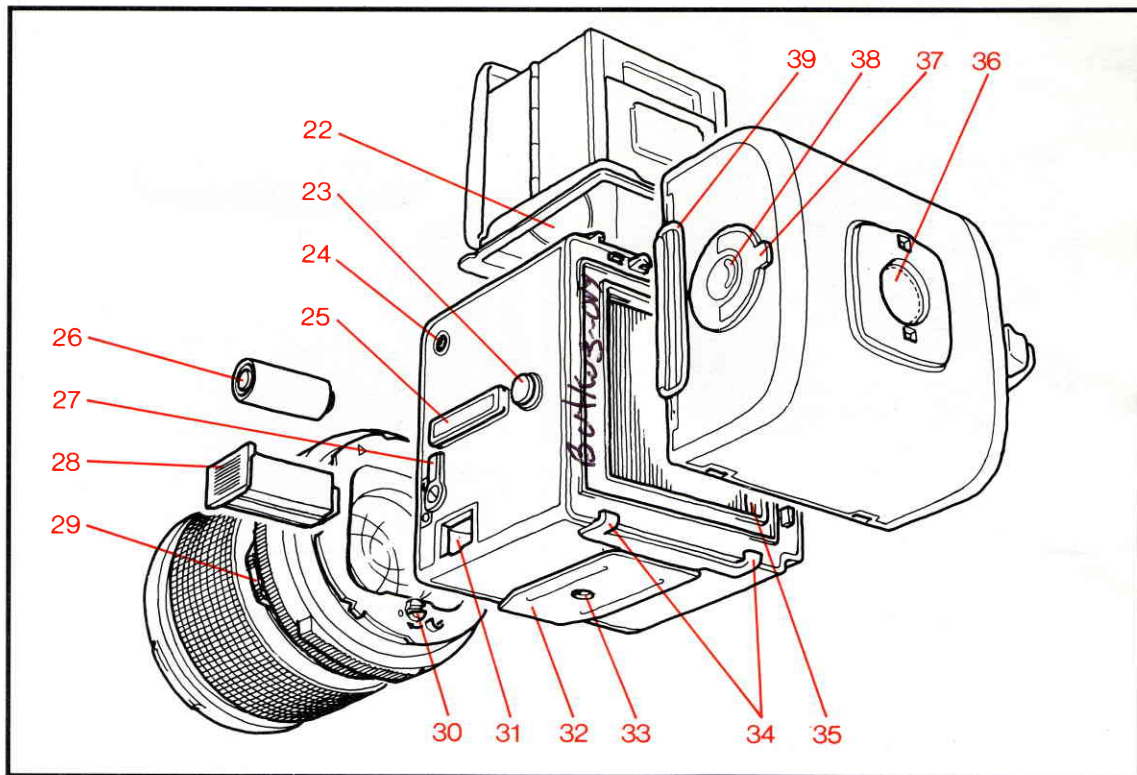

22 Interchangeable view-
finder magnifier

23 Strap lug

24 Focal plane shutter
PC outlet

25 Accessory rail

26 Battery

27 Shutter speed ring
locking lever

28 Battery cassette

29 Depth-of-field preview
button

30 Lens drive shaft

31 Battery compartment

32 Quick coupling plate

33 Tripod socket 1/4 "
2003FCW socket: 3/8 "

34 Magazin supports

35 Focal plane curtain

36 Film speed and type
indicator

37 Film holder key

38 Film consumption indicator

39 Magazin slide



Front protective cover

Turn the cover (bayonet fitting) in the direction of the arrow, and remove.

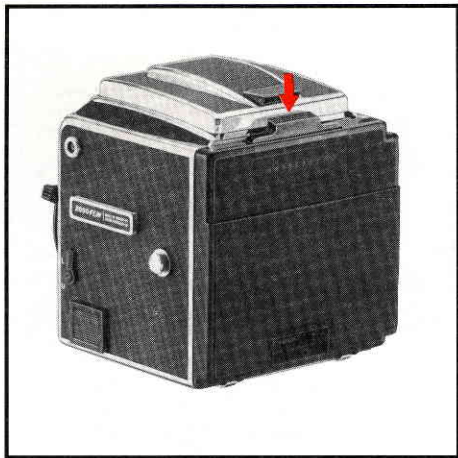

Rear protective cover

Depress the catch and swing back the cover. Lift the cover off the magazine supports.



Attaching the magazine

Insert the magazine slide into the magazine. Locate the magazine on the magazine supports. Slide the magazine catch to the right, then hinge the magazine forward into contact with the camera body. Release the magazine catch, ensuring that it returns to the left—locked position.

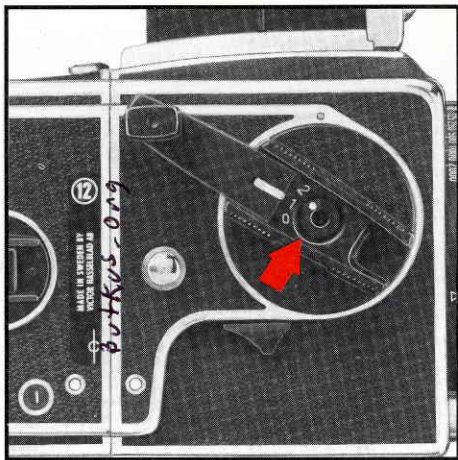

Cocking the shutter

The focal plane curtain is protectively released when a magazine is removed from the camera body. It must therefore be re-cocked after attaching a magazine.

Use a fingertip to depress the double exposure button in the center of the winding crank. Turn the crank clockwise a little, whilst keeping the button depressed. Now release the double exposure button and continue the wind until the crank stops. The shutter is now fully cocked.

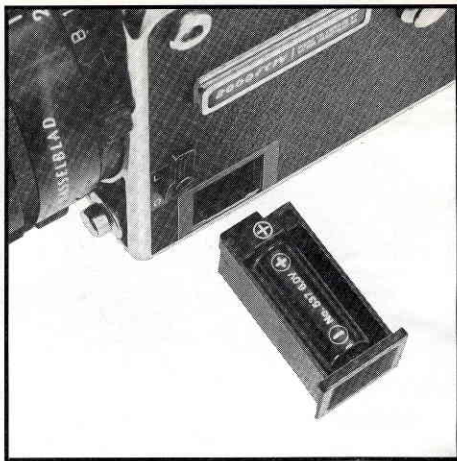

The battery

The electronic circuit, which precisely controls the focal plane shutter speeds, is powered by a 6 volt battery (PX 28 or equivalent). Batteries with a voltage of less than 6 volts must not be used.

Withdraw the battery cassette and insert the battery with its (+) terminal towards the cassette's (+) index.

Insert the battery cassette into the camera.

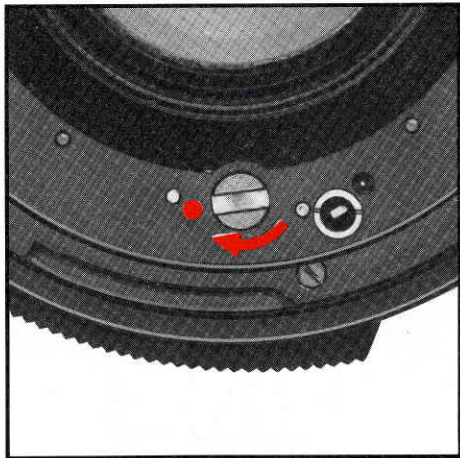
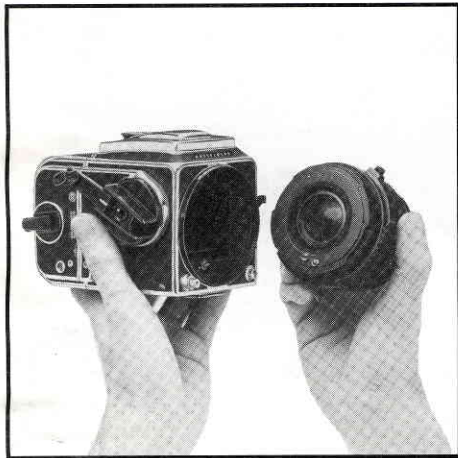

Fitting a Hasselblad lens

Ensure that the lens is cocked.

The slot on the drive axle must be aligned with the adjacent red dot, as shown in the picture. If not, then insert a coin in the drive axle slot and *turn in the direction of the arrow* until it locks.

Align the red index on the lens bayonet with the corresponding index on the body bayonet.

Insert the lens and rotate it clockwise. A faint click can be heard as the lens lock drops into place. The lens will now turn no further and is fully locked on.

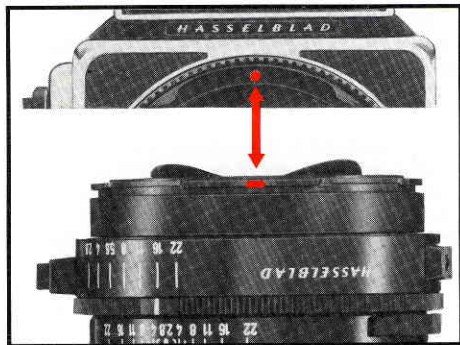

Lens removal

Depress the lens release button and rotate the lens counterclockwise about one fifth of a turn.

Note that lens removal is only possible if the camera is cocked (fully wound).

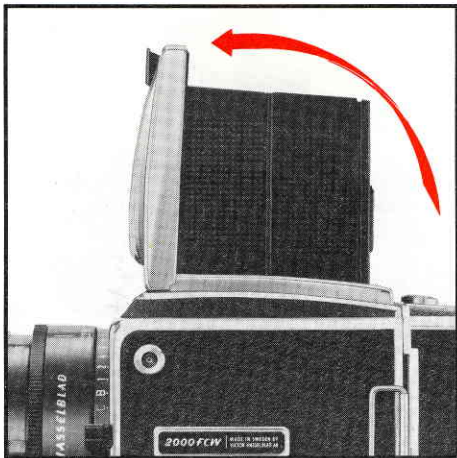

Opening the focusing hood

Lift the lid firmly at the rear edge, and swing it up to the vertical position. The sides fold up automatically.

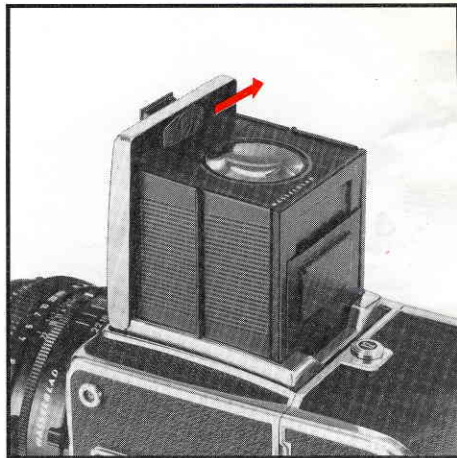

The built-in magnifier

The magnifier flips up into the viewing position when the oval button is moved in the direction of the arrow.

To re-fold the magnifier simply press it down with a fingertip until it locks back into the lid.

The magnifier may be changed for a correction lens. See page 19

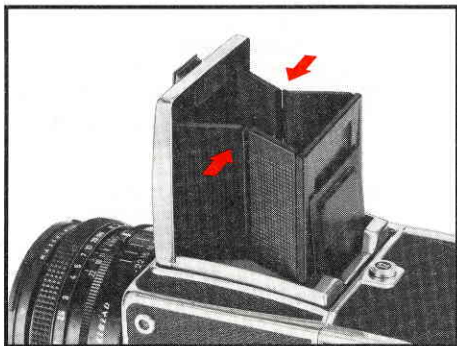

Closing the focusing hood

"Pinch" in the side plates at the hinge points, and fold down the lid.

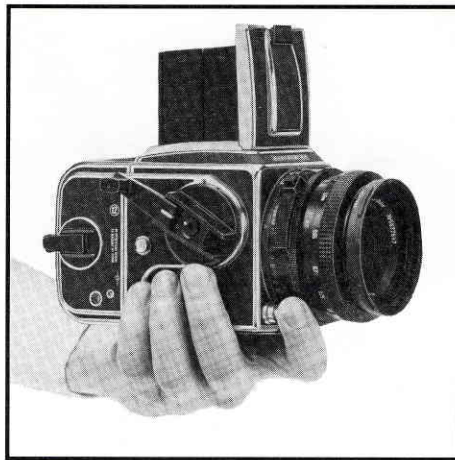

Focus and shoot

Remove the magazine slide from the magazine. A safety interlock now prevents magazine removal. The release button (previously blocked) is freed ready for exposure.

Rotate the focusing ring on the lens until the subject is sharp in the viewfinder.

Depress the shutter release button to fire the camera.

The camera may now be rewind, or can be wound just prior to the next exposure. The latter preventing accidental exposure.

Left hand grip

The accompanying picture shows the best way to hold a 2003FCW whilst shooting.

The camera is cradled in the left hand with the left index finger on the release button and the other fingers resting on the rubber grip-pad.

This leaves the right hand free for rewinding, focusing, exposure setting and change of lens or magazine.

Make a habit of the left hand grip!



Lenses

Since the early 1950's Hasselblad lenses have been manufactured by Carl Zeiss in West Germany. All of these lenses can be used with the 2003FCW as can the zoom lens made by Schneider in West Germany.

Over the years, natural development and design changes have resulted in Hasselblad lenses being divided into three main groups: CF and C lenses which have built-in central leaf shutters, and F-lenses that have no shutter and can therefore only be used with the Hasselblad 2000 series.

Manufacture of C-lenses is discontinued.

F-lenses

F-lenses have been developed solely for use with the 2000 series Hasselblad cameras and are shutterless. The camera's focal plane shutter is used exclusively with these lenses. The aperture setting ring is positioned closest to the camera body so, through a simple mechanism, both shutter and diaphragm rings can be locked together for cross-coupling. In this manner the speed/aperture combination may be changed without altering the exposure value (EV).

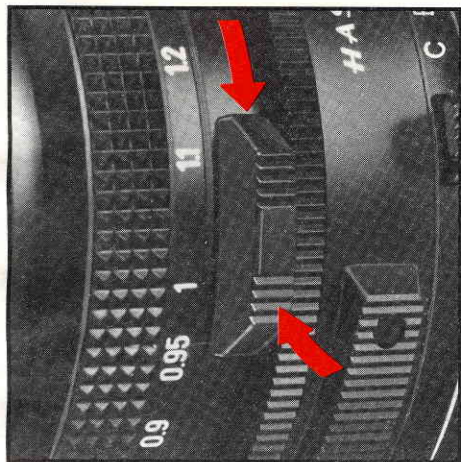

Depth of field scale

The depth of field scale adjoins the focusing distance scale and shows the depth of field at different diaphragm openings.

Depth of field may also be viewed by stopping down the diaphragm to the required aperture and viewing the resulting image on the focusing screen.

To stop down the diaphragm simply slide the manual preview button downwards until it locks into the preview position.

To release the button, and reopen the diaphragm, press in the lower section of the button.

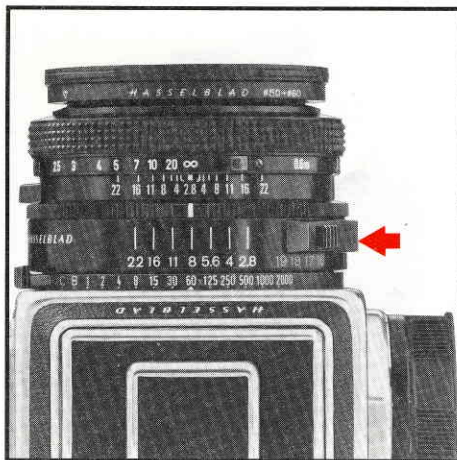

Interlocked shutter speed/aperture

When the interlocking button is depressed, the lens aperture ring and the camera's speed ring are locked together and rotate simultaneously. In this manner, speed/aperture combinations may be altered, without change in exposure value (EV).

Operating the 2003FCW with CF-lenses

CF-lenses are fitted with a central (leaf) shutter and can be used with all Hasselblad single lens reflex cameras.

The "F" button locks out the central shutter function, and the lens may be used in conjunction with a 2003FCW at all focal plane shutter speeds. The camera's focal plane shutter may also be "locked out" and the lens shutter used as the primary means of exposure.

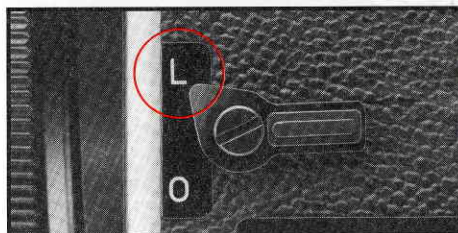
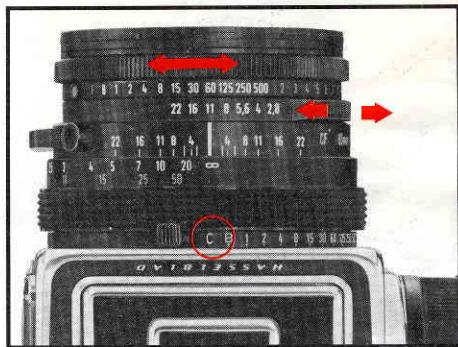

A 2003FCW with a CF-lens makes two shutter systems available. The choice of system will depend upon the individual requirements of a particular exposure.

With the focal plane shutter, exposures as short as 1/2000 s are available.

The central shutter provides electronic flash synchronisation from 1 s to 1/500 s.

CF-lenses have the same type of aperture preview button and speed/aperture interlock as the F-lenses.

Setting the central shutter mode (C-mode)

Rotate the camera's shutter speed ring to the "C" position. Lock the speed ring by turning the locking lever (camera's left side) to the "L" position.

The camera's focal plane shutter now becomes an untimed auxiliary with the lens's central shutter taking over the task of exposure and timing. The 2003FCW works with all the central shutter speeds, and *using the lens synchronization contact*, will synchronize electronic flash from 1 s to 1/500 s. In the C-mode with a CF-lens, the 2003FCW is in a mechanical mode and is not reliant on power from the battery.

Note 1. The viewfinder image does not return instantly in C-mode. It returns during the wind, as the camera is re-cocked.

Note 2. In C-mode the release button must be held in until the central shutter has finished operation. Otherwise the exposure will be interrupted.

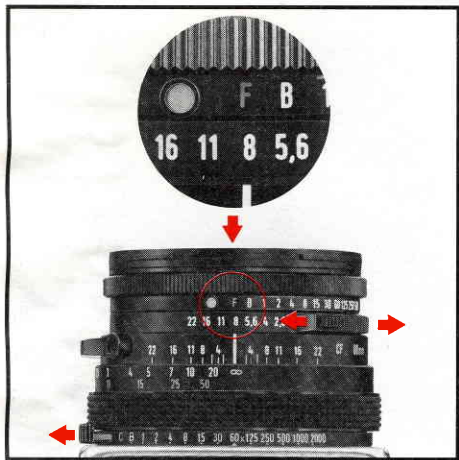

Selecting the focal plane shutter mode (F-mode)

Disengage the central shutter by depressing the green button and turning the speed ring until the "F" marking is opposite the white index.

Set the required shutter speed on the camera speed ring.

Set the required aperture.

Note. The interlocking mechanism must not be engaged when the CF-lens is in the F-mode.



Operating the 2003FCW with C-lenses

Basically these lenses operate in similar way to the CF-lenses when used with the Hasselblad 2003FCW. There are however certain differences that one should be aware of.

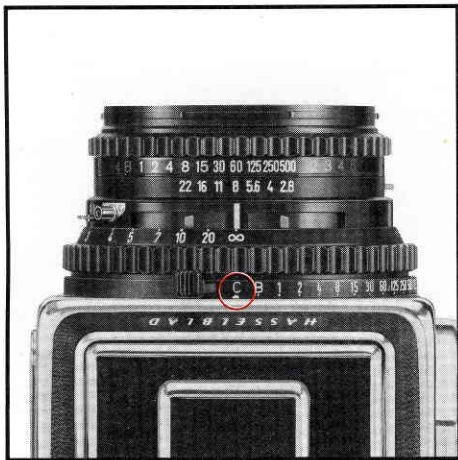

Selecting the central shutter mode (C-mode)

Set the camera's speed ring to "C" and lock it.

Set the required speed and aperture on the lens.

The following points should be noted:

1. "C" lenses have both X and M flash synchronization (X for electronic flash, and M for bulb flash). A lever adjacent to the synchronization contact is used to change modes.
2. The self-timer on C-lenses can be used, but requires a lockable cable release in order to operate correctly.
3. The viewfinder image does not return after exposure. It returns as the camera is rewind.

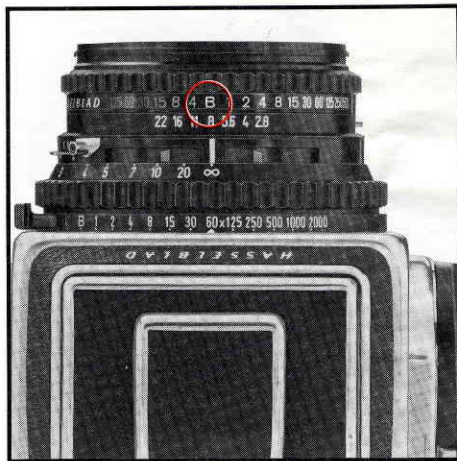

Selecting the focal plane shutter mode (F-mode)

Set the lens shutter speed ring to "B".

Set the synchronization lever to "X".

Set the required shutter speed on the camera's speed ring.

Set the required aperture on the lens—taking care not to move the speed ring from the "B" position.

The following should be noted:

1. The self-timer cannot be used in the F-mode.
2. No instant return mirror function is visible through the viewfinder—the viewfinder image returns upon rewinding the camera.

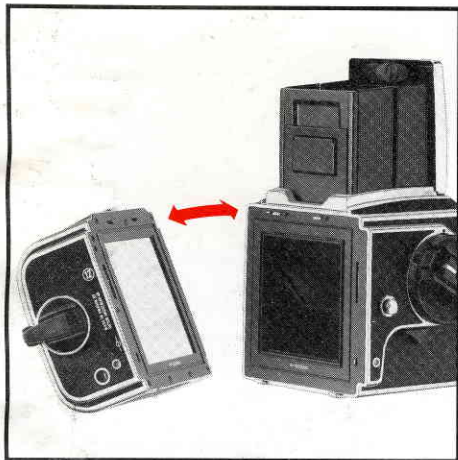

The focal plane shutter.

Shutter protection mechanism

Removal of a magazine results in the first curtain of the focal plane shutter being automatically retracted. Resetting the first curtain should be undertaken following the steps set out under Recocking the camera-shutter only. See page 7.

Note. When the Hasselblad winder is attached to the 2003FCW, the first curtain is automatically rewound to its fully tensioned position when a magazine is replaced on the camera.

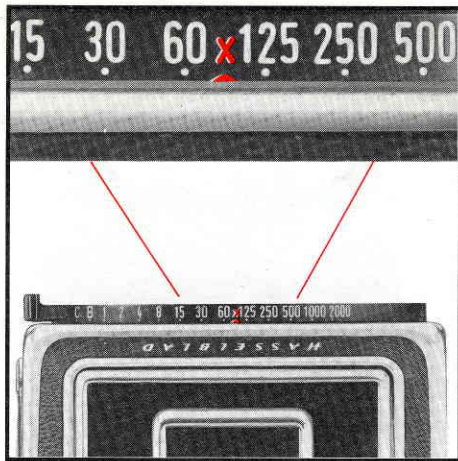

Focal plane shutter speeds

The Hasselblad 2003FCW has a shutter speed ring showing speeds from 1 second to 1/2000 s, in addition to "C" and "B". Between each indicated speed is an unmarked "click-stop" corresponding to values halfway between the indicated speeds.

One of the intermediate speeds is in fact marked in red—that is the 1/90 s stop. This is the fastest speed for synchronized electronic flash. At speeds faster than 1/90 s the flash contacts do not engage, and the strobe will not light.

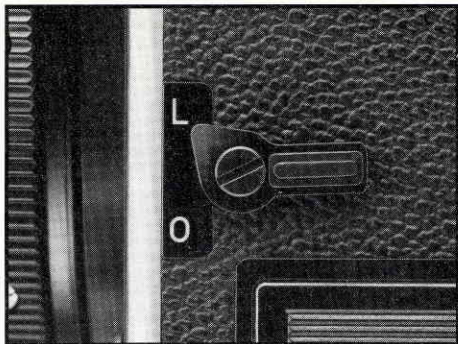

Locking the shutter speed ring

A convenient lock on the camera's left side enables the shutter speed ring to be fixed at any selected speed, or function.

L = Locked

O = Open.

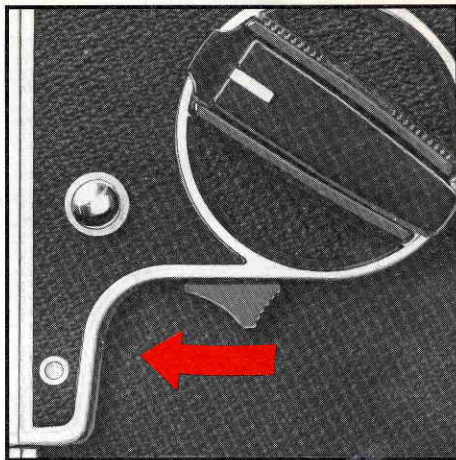

Pre-releasing the camera (mirror up)

Pre-releasing the camera mechanism allows virtually vibration free photography, and reduces the camera's reaction time to a minimum.

The pre-release button is located under the winder crank. Slide it to the rear to effect a release.

When the main exposure release is subsequently depressed, only the shutter will be operating.

Resetting the pre-released camera for conventional operation may be effected in the same manner as under "Cocking the shutter" on page 7.

The 2003FCW is provided with a sign close to the pre-release button to show the operation.

Flash photography

	C-lenses		F-lenses	CF-lenses	
	1 s—1/500 s	B setting		1 s—1/500 s	F setting
Bulb flash	M-sync.	No special setting possible. Note. When using C-lenses in the “F”-mode <i>M synch. may not be used.</i>			
Electronic flash	X-synch.	X-synch.	Only designed for X-synch.		
Camera's shutter speed ring	C-mode	1 s—1/90 s	1 s—1/90 s	C-mode	1 s—1/90 s
Flash-connection	To lens	To camera	To camera	To lens	To camera
Fastest synch. speed	1/500 s	1/90 s	1/90 s	1/500 s	1/90 s.

Flash connections:

To the camera

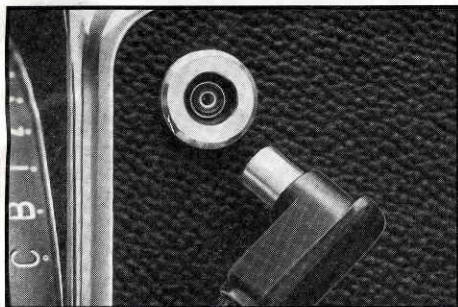

The table shows the possible combinations, settings, and the fastest speeds at which flash synchronization can be obtained with the 2003FCW, when used with different Hasselblad lenses.

Note. When the Hasselblad 2003FCW is used together with the Hasselblad winder for rapid sequences it is possible that the camera will recycle faster than the flash recharges. This can result in underexposure.

Set your strobe to the “winder” setting—if available.

CF-lenses

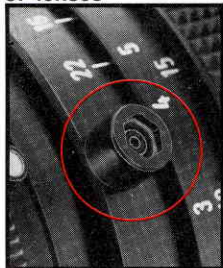

C-lenses

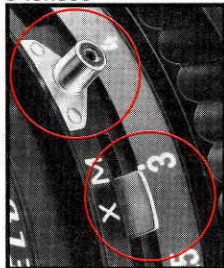



Change of focusing hood or viewfinder

The film magazine must be detached before the focusing hood or other viewfinder can be removed.

Remove the hood by sliding it rearwards in its guide slots. Slide the replacement finder into the slots, and push it forward.

Attach a magazine to the camera and re-cock the focal plane shutter as described on page 7.

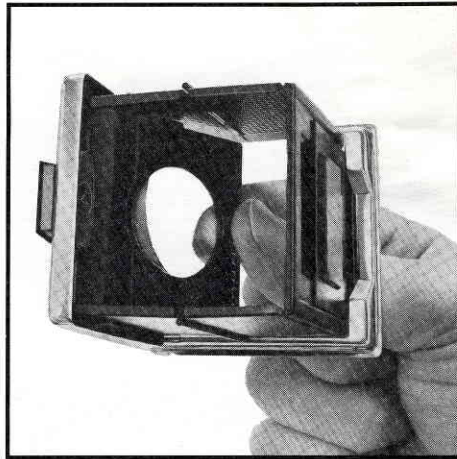

Changing the magnifier

The focusing hood has an easily interchangeable magnifier if you should need to compensate for your individual eyesight.

Lenses with Correction Factors from +3 to—4 are available and easily interchangeable by following these instructions:

Remove the focusing hood from the camera and open it.

Bring the magnifier to the viewing position.

Push the magnifier half way back to its folded position.

Through the underside of the hood, grip the lower edge of the magnifier between thumb and forefinger and pull firmly.

Insertion of the replacement magnifier is the reverse of the above procedure.

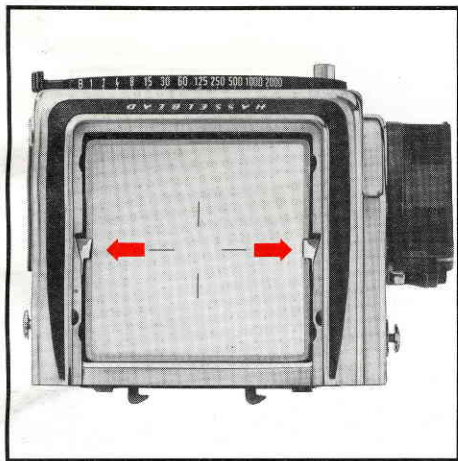

Changing the focusing screen

The screen is quickly interchangeable without the requirement of special tools.

Detach the magazine and viewfinder.

Slide the screen latches to the side.

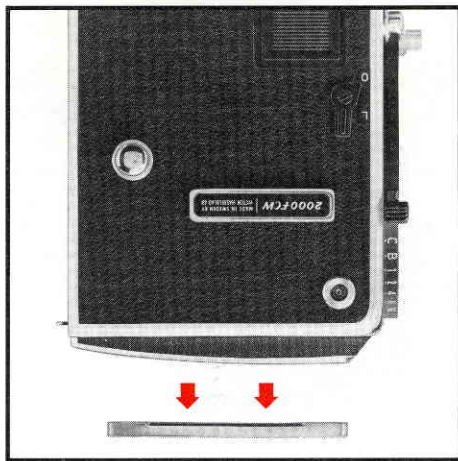

Place your hand over the screen, and invert the camera. The screen will now drop into your hand.

Insert the replacement screen, ensuring that the smooth flat side of the frame is uppermost, and that all four corners are seated on the support pins.

It is not necessary to return the screen latches. This is done automatically when the viewfinder is replaced.

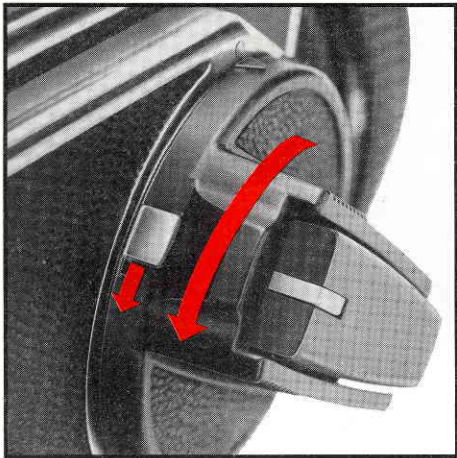

The winding crank

One complete revolution of the winding crank cocks the camera and lens, and transports the film one frame.

The mirror mode selector and winder bayonet are located behind the crank. Selecting a new mirror mode, or attaching the winder, necessitate that the crank be removed.

It is preferable that the camera be fully wound-on during removal, and especially during replacement of the crank.

Removing the crank

Push down on the latch at the rear of the crank and turn off the crank, counter clockwise.

The winder is removed in a similar manner, but in this case the latch is pulled out a little.

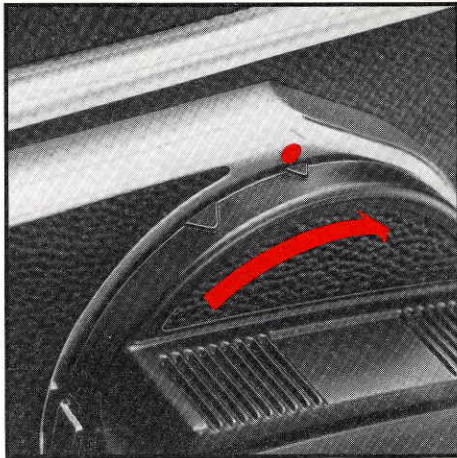

Fitting the crank

Locate the crank against the camera's crank fastening bayonet. The smaller of the crank's two triangular indices must be opposite the bayonets location index.

Push the crank in lightly, and rotate it in a clockwise direction until the larger of the two crank indices is opposite the red index.

The winder is attached in a similar manner.

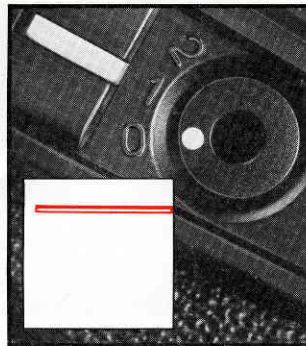
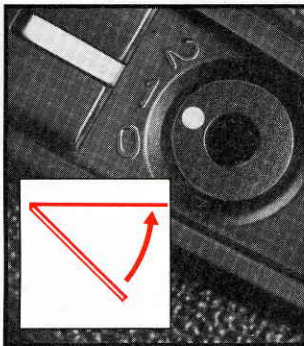
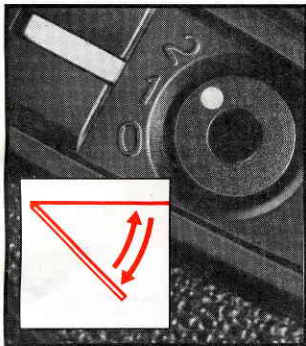

The mirror action modes

The Hasselblad 2003FCW has three choices of mirror action. The selector for these modes is accessible upon removal of the crank or winder.

Mode 2: Instant return mirror

Mode 1: Rewind return mirror

Mode 0: Mirror locked up in the raised position

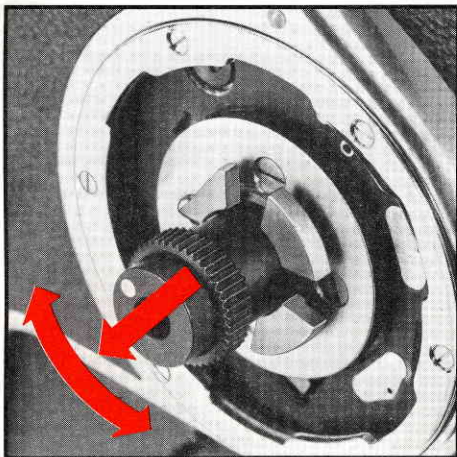



































Selecting a mirror action mode

Remove the crank, or winder.

Pull out the knurled ring at the end of the shaft, and rotate it to the desired mode setting. The upper position is *Mirror mode 2*, the middle is *Mirror mode 1*, and the lower position is *Mirror Mode 0*. The fact that the mirror returns instantly in mirror mode 2 does not necessarily mean that the viewfinder image returns also.

The table on the next page shows the practical results of different mirror modes in conjunction with various lens types, and shutter systems.

Mirror-mode	Setting	Mirror-movement	Lens	Setting—shutter speed ring		Before exposure	After exposure	Wind	Camera—fully-cocked
				Lens	Camera				
2			F	—	B-1/2000				
			CF	F	B-1/2000				
			CF	B-1/500	C				
			C	B	B-1/2000				
			C	B-1/500	C				
1			F CF C	See above					
0			F CF C	See above					

 Viewfinder image  No viewfinder image

Mirror mode 2

The mirror reaches its fully retracted position immediately prior to exposure, and returns automatically when exposure is completed.

Mirror mode 1

The mirror reaches its fully retracted position immediately prior to exposure, and does not return until the camera is rewound.

Mirror mode 0

The mirror retracts when the camera is released the first time after setting mirror mode 0. The

mirror stays retracted until either mirror mode 1 or 2 are once again selected, at which point the camera must be re-cocked, as described on page 7.

The mirror will flip down if the mode selector is moved from mirror mode 0 to mirror mode 2 when the camera is in a triggered state.

Mirror mode 0 eliminates mirror vibration in critical situations where a series of shots are taken, and also allows the use of special lenses which protrude into the camera body.

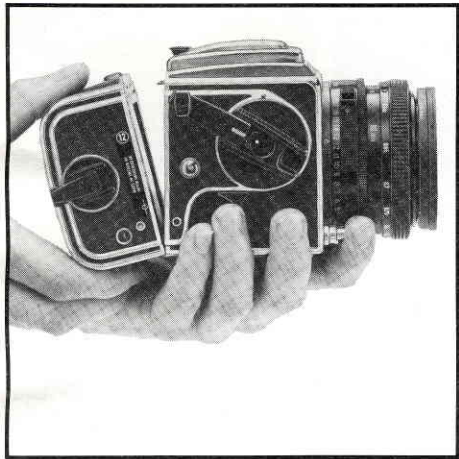

The film magazine

Removing the magazine

Ensure that the camera is cocked. The magazine indicator window should display white. If the magazine indicator window shows red, then follow the instructions on the next page.

Insert the magazine slide into the magazine. Slide the magazine catch to the right. Swing back the magazine and lift it off the lower supports. The magazine cannot be removed without inserting the magazine slide. The slide protects the film from fogging. Note also that the camera cannot be fired when a magazine, with a slide inserted, is attached to the camera.

The first curtain of the focal plane shutter is protectively retracted when a magazine is removed. With the curtain "open" no inadvertent damage can be done to the shutter.

Note. If a magazine is removed from a released camera, the curtain will be visible and unprotected.

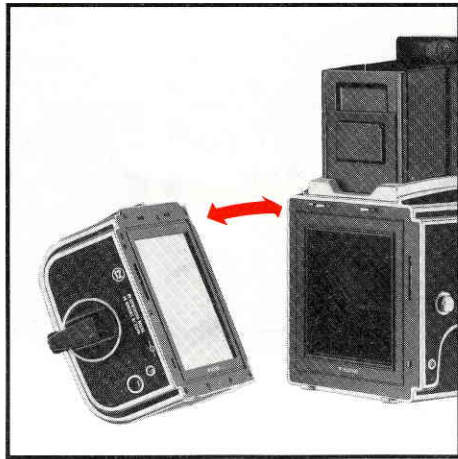

Attaching a magazine

Ensure that the magazine slide is fully inserted and that the indicator signal is white. If not, then refer to the instructions on the next page. The camera should be cocked.

Locate the magazine on the magazine supports—see that it is fully seated on the supports. Slide the magazine catch to the right, and hold it here whilst swinging the magazine into contact with the camera's rear plate.

Release the magazine catch, ensuring that it returns to the left—locked position.

Rewind the protectively released first curtain by following the instructions on page 7.

Remove the magazine slide and the camera is ready to shoot.

WARNING! All Hasselblad magazines can be used with the 2003FCW, **with the exception of the Hasselblad Polaroid 80 magazine.** The projecting glass screen on this magazine will destroy the focal plane shutter.

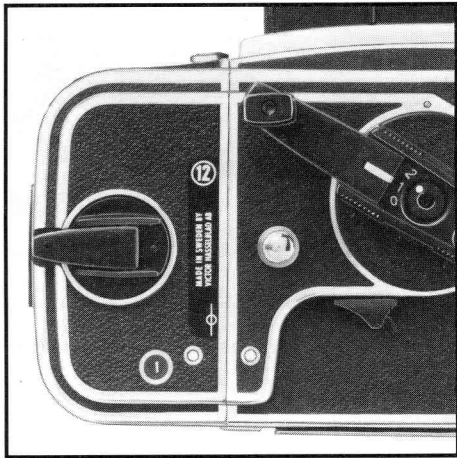

The 2000FCW: Camera signal

The 2000FCW has a status indicator signal below the strap lug on the right hand side of the camera body. The function is similar to that on the magazine.

White signal: The camera is rewound and ready for release.

Red signal: The camera is released but not rewound.

WARNING!

When the camera signal is red, the secondary shutter curtain is exposed and does not retract if the magazine is removed. Always be very careful when handling the camera in this condition!

The magazine indicator signal

NOTE: The 2003FCW has no status indicator.

The status indicator signal on the right hand side of the magazine shows whether the film has been advanced (white) or not (red).

When the magazine is attached to a camera body the signal also indicates whether the camera has been rewound and is ready for release (white) or released but not rewound (red).

The general rule when attaching a magazine to a camera body is that the camera should be rewound (the winding crank is locked) and the magazine signal white.

Follow the procedures below to make the camera and magazine status match:

Magazine red—Camera rewind

Remove the magazine from the camera.

Release the camera.

Attach the magazine **cautiously**. The shutter curtain is exposed!

Rewind the camera with one full turn of the winding crank.

The magazine signal is now displaying white.

Magazine white—Camera released

Depress the double exposure button in the center of the winding crank and turn the crank one full turn.

The camera has now been rewound without the film being advanced. The magazine signal remains white.

Only when you are making double exposures should you accept a red magazine signal on a rewind camera (see page 28).

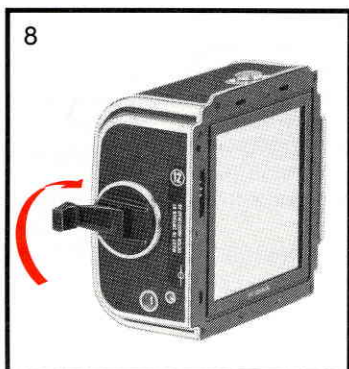
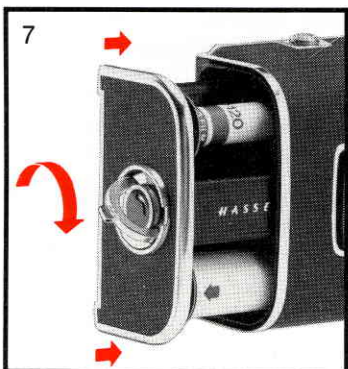
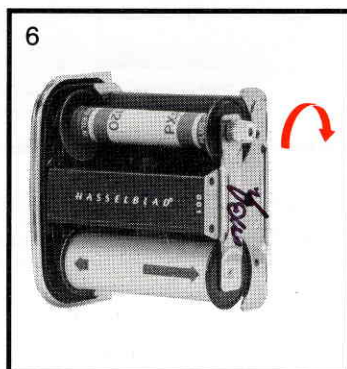
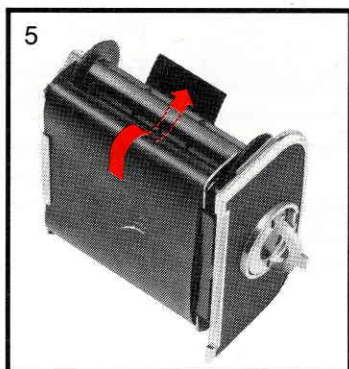
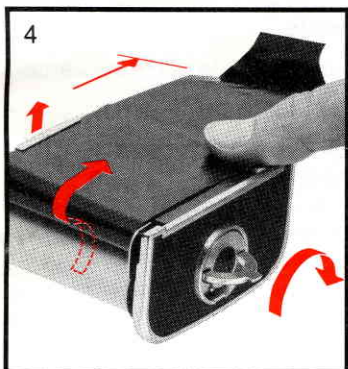
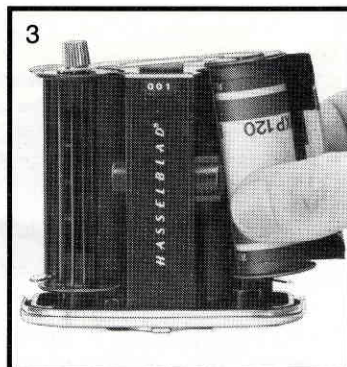
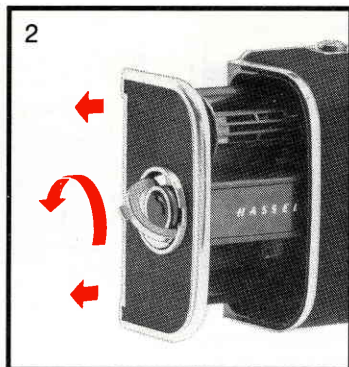
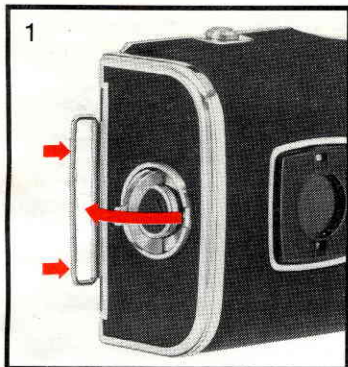

Loading the magazine

The magazine may be loaded on, or off the camera. If the magazine is to be loaded off the camera then the magazine slide must be inserted, and have its flat side towards the rear of the magazine. This facilitates removal of the film holder for loading.

1. Fold out the film holder key.
2. Turn the key **counter-clockwise** and withdraw the film holder.
3. Place an empty spool under the spool clamp holder bar—closest to the knurled knob. Insert a roll of film under the other end of the bar, ensuring that it is turned the same way as in the picture.
Be careful to remove *all* the paper tape that surrounds a new roll of film.
4. Turn the filmholder key *clockwise* so that the film clamp opens. Pull 3 to 4 ins. (8—10 cm) of paper backing off the film roll and slide the edge under the clamp.
5. Insert the tongue of the backing paper into the slot in the take-up spool.
6. Turn the knurled knob *clockwise*, until the arrow on the paper is opposite the triangular index on the spool clamp bar.
7. Turn the film holder key *counter-clockwise* so that the film is caught under the clamp, and insert the film holder into the magazine—jiggling it a little if it does not click into place. Lock the holder into the magazine by turning the key clockwise.
8. Fold out the film crank and rotate it *clockwise* about ten turns until it stops. Refold the crank. Number 1 will now be displayed in the frame counter window and the magazine is loaded—ready for use.

Note. The magazine can only be removed if the magazine slide is inserted.

The camera cannot be fired when a magazine, with slide inserted, is attached to the camera.

Removing film from the magazine

When the last frame has been exposed and wound on, the magazine is blocked for further release.

Wind off the film by folding out the film winding crank, rotating it clockwise until the film is felt to clear the spool.

The filmholder may now be withdrawn from the magazine and the exposed film removed.

General

The magazine's film winder crank is only blocked at frame no. 1. A partially exposed film may be wound off at any frame thereafter.

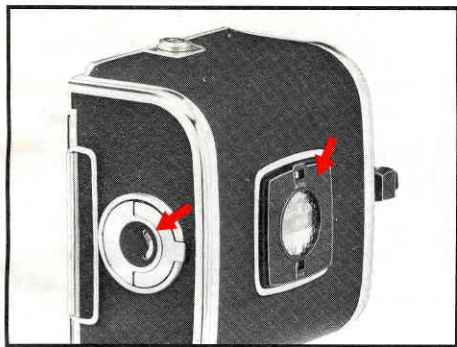

The load status and film type indicators

In the center of the film holder key is a crescent shaped indicator that displays white when the film is loaded, and progressively changes to red as the film is wound on. A completely red signal indicates that either the final frame is exposed, or that the magazine is empty.

The film indicator at the rear of the magazine can be set to the sensitivity of the film in use—in ASA or DIN.

The indicator hinges out to accept the film carton lid, reminding the user of film type, as well as sensitivity.

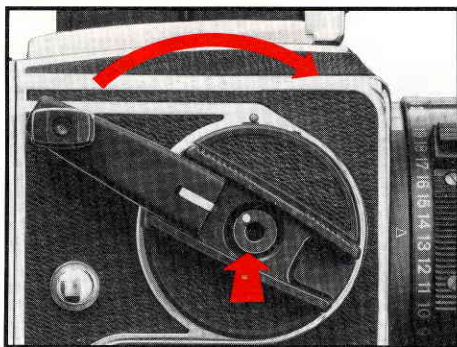

Double exposure

By using the double exposure button in the center of the winding crank it is simple matter to purposely double expose a film frame.

First make an exposure in the normal manner, then depress the mirror mode indicator and turn the winding crank a little. Release the button and continue to wind the crank until it stops. This procedure rewinds the camera without transporting film, and a new (second) exposure may be made on the same frame.

Note: The magazine now displays a red signal until the camera is rewound in a normal way.

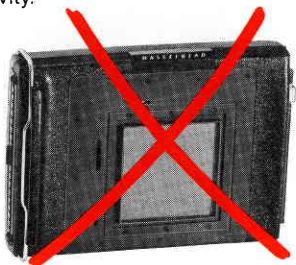

WARNING!

The Hasselblad Magazine 80 for Polaroid-film must never be used with the Hasselblad 2003FCW. The magazines projecting glass plate will destroy the focal plane shutter.



Accessory Mounts

On the bottom of the camera body a 1/4 in. thread tripod socket is located in the centre of the quick coupling plate. The plate and socket accept flash gun brackets and the plate also fits and easily locks into the Hasselblad Tripod Quick-coupling.

If you own tripods and other accessories with 3/8 in. screws we recommend you to purchase the Tripod Quick-coupling which has both 1/4 and 3/8 in. sockets and provides an easily operated, fast and reliable tripod connection.

Should a Quick-coupling be unsuitable for your application, your Hasselblad distributor can, upon request provide a replacement 3/8 in. socket together with installation instructions.

On the left hand side of the camera body in front of the strap lug there is an accessory rail for the Flash Adapter and other accessories. The lenses accept filters and lens shades on the front bayonets.

The strap lugs are designed so as not to be in the way, even if the camera is used without a strap.

The right hand lug also serves as one of the fasteners for the Hasselblad winder.

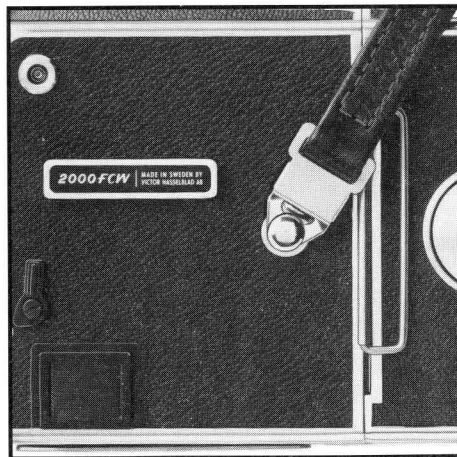



Special accessories

The Hasselblad Winder

The removable winding crank can be replaced by a husky, battery powered winder. This can be attached, or removed as easily and quickly as the crank, and requires no extra connections.

With a winder the Hasselblad 2003FCW is transformed into an efficient motor camera—always ready for that “once in a lifetime shot” and with the possibility of exposing sequences at 1.3 frames per second. One battery charge is sufficient for about 1000 exposures.

Hasselblad Accessory Chart

The accessory chart on page 2 indicates the wide range of accessories available within the Hasselblad System. Please refer to the Hasselblad Product Catalogue for complete information on the entire Hasselblad Camera System.

PME 3/PME Meter Prism Viewfinder Adjustments

Since the Hasselblad Meter Prism Viewfinders measure the light level on the focusing screen they have been calibrated at the factory to give an accurate reading with one particular type of screen. If that focusing screen is replaced with another type which gives a different light level under the same ambient conditions, the meter has to be adjusted to compensate for the difference.

The PME 3 and PME meter viewfinders are basically the same design but are adjusted differently from the factory. The PME 3 type is adjusted to the brighter Acute-Matte* screen in the 2003FCW camera while the previous PME type is adjusted to the lower light level of the other Hasselblad screens, such as Split Image (42188), Central Grid and Split Image (42218) and the Checked and Central Grid (42250). The Plain Glass Screen (42200) is not suitable for TTL measuring.

The distinction between the two viewfinder types is indicated by the designation PME 3 on the rear of the viewfinder body above the eyepiece. The PME has no designation.

The ways of compensating for alternative usage of the meter viewfinders are shown in the charts on the next page.

* Acute-Matte designed by MINOLTA.

A. Acute-Matte* focusing screen, combined with:

Viewfinder model	Adjustment or action required to obtain the correct EV value
PME 3	No adjustment or action required
PME	<p><u>Reduce</u> the ASA/ISO setting to half the film speed value as indicated on the film package (e.g. to 50 for a 100 ASA film).</p> <p>or</p> <p><u>Increase</u> the MAX lens aperture setting one full step (e.g. to f2 for an f2.8 lens)</p> <p>or</p> <p><u>Reduce</u> the EV reading one full step when setting it on the lens EV scale (e.g. to EV11 instead of EV12).</p>

B. Other Hasselblad focusing screens, combined with:

Viewfinder model	Adjustment or action required to obtain a correct EV value
PME 3	<p><u>Increase</u> the ASA/ISO setting to twice the film speed value as indicated on the film package (e.g. to 200 for a 100 ASA film).</p> <p>or</p> <p><u>Reduce</u> the MAX lens aperture setting one full step (e.g. to f4 for an f2.8 lens)</p> <p>or</p> <p><u>Increase</u> the EV reading one full step when setting it on the lens EV scale (e.g. to EV13 instead of EV12).</p>
PME	No adjustment or action required.

* Acute-Matte designed by MINOLTA

Camera Care, Service and Guarantee

Camera Care

Your Hasselblad camera is designed to withstand the rigours of professional use in most environments. In order to avoid the possibility of damage however, the camera should be protected from the following.

Extremes of temperature. High temperatures can have an adverse effect on both the film and the camera. For this reason you should not keep your camera in places where it will get hot, such as in direct sunlight or on a shelf above a radiator. In tropical environments fungus growth can be prevented by ensuring your equipment is kept in an area where the air is circulating. Frequent rapid and severe temperature changes can cause problems such as the corrosion of electrical contacts, and should therefore be avoided. When working in extremely cold temperatures, cameras and especially lenses should be protected as much as possible.

Dust and grit. You should take care to prevent dirt of any kind from getting into your camera. When taking photographs in coastal areas for example, the camera should be protected from sand and salt water spray.

You can blow away any dust on the lens glass, magnifier or focusing screen, or wipe it off gently with a soft cloth if necessary. Smears on the lens glass should be removed with a high quality lens cleaning solution on a soft, clean tissue. Be careful not to scratch the lens or touch any of the glass surfaces with your finger. The surface of the mirror is coated and can be blown clean but

should not be wiped. Lens cleaning solvents or other chemicals should not be used on the focusing screen.

Impact. Your camera can be damaged by severe physical shocks. While you will obviously try not to drop it, you should also take care not to leave it where it can fall or be knocked to the ground, or roll about, as on the back seat of a car for example.

Service

Faultless camera performance is essential to the professional photographer. It is therefore advisable to check that your camera is functioning correctly before an important assignment. You should also return your camera to a Hasselblad service centre for occasional checking and preventive maintenance. If your camera is used constantly and intensively, exposing for example hundreds of rolls of film per week, check-ups every six months are recommended. Hasselblad service centres have the expert staff and specialized equipment necessary to ensure that your camera remains in perfect working order.

Guarantee

Provided that you bought your camera from an authorised Hasselblad outlet, it is covered by an international guarantee for one year. The guarantee document and a registration card are supplied with the camera. Keep the guarantee document carefully, but fill in the registration card and return it to your Hasselblad distributor.