

INSTRUCTION MANUAL

DRAKE

MODEL

TR-6

6M TRANSCEIVER



R. L. DRAKE COMPANY • MIAMISBURG, OHIO

TABLE OF CONTENTS

I.	General Description	3
II.	Specifications	
	A. General	4
	B. Receiver	5
	C. Transmitter	6
	D. Power Requirements	7
III.	Unpacking	7
IV.	Manual Controls, Jacks, and Indicators	
	A. Front Panel	8
	B. Side	10
	C. Rear	12
V.	Installation	
	A. Antenna	14
	B. Power	14
	C. Speaker and Headphones	14
	D. Key and Microphone	14
	E. Location	15
	F. Fixed	16
	G. Mobile	16
	H. Installation With Other Accessories	17
	I. Use in Aircraft	18
VI.	Tuning Procedure	21
VII.	Operation	
	A. SSB VOX	24
	B. SSB PTT	24
	C. CW	25
	D. AM	25
	E. General Precautions Near Band Edges	26
	F. Operation With Linear Amplifiers	26
	G. RTTY Operation	27

VIII.	Theory of Operation	
	A. Receiver Circuitry	28
	B. Transmitter Circuitry	29
	C. Transceiving Circuitry	29
IX.	Service Data	33
X.	Alignment Instructions	35
XI.	Electrical Parts List	42
XII.	Accessory Information	54

ILLUSTRATIONS

Fig. #1	Front View	3
Fig. #2	Side View	11
Fig. #3	Rear View	13
Fig. #4	Microphone Connection	15
Fig. #5	Connection of TR-6 with AC-3, RV-6, and Linear Amplifier	18
Fig. #6	Connection of TR-6 with DC Power Supply	19
Fig. #7	Connection of TR-6 with AC-4, MS-4, R-4B, and SC-2	19
Fig. #8	Viewing Angle Options	20
Fig. #9	Block Diagram	30
Fig. #10	Voltage Chart	31
Fig. #11	Resistance Chart	32
Fig. #12	RF Voltage Chart	34
Fig. #13	Bottom View	40
Fig. #14	Top View	41
Fig. #15	Accessory Crystal View	53
Fig. #16	Schematic Diagram Fold-out	

I. GENERAL DESCRIPTION

The R.L. Drake model TR-6 is a radio transceiver which, in conjunction with an external fixed or mobile power supply and a suitable antenna, permits two way radio communications on any frequency in the 6 meter amateur band as well as on adjacent frequencies.

The mode of transmission and reception is switchable. The unit is capable of communicating in the SSB, AM, FSK, and keyed CW modes. Appropriate modulators and detectors are provided for each mode, as well as switching for appropriate IF filters.

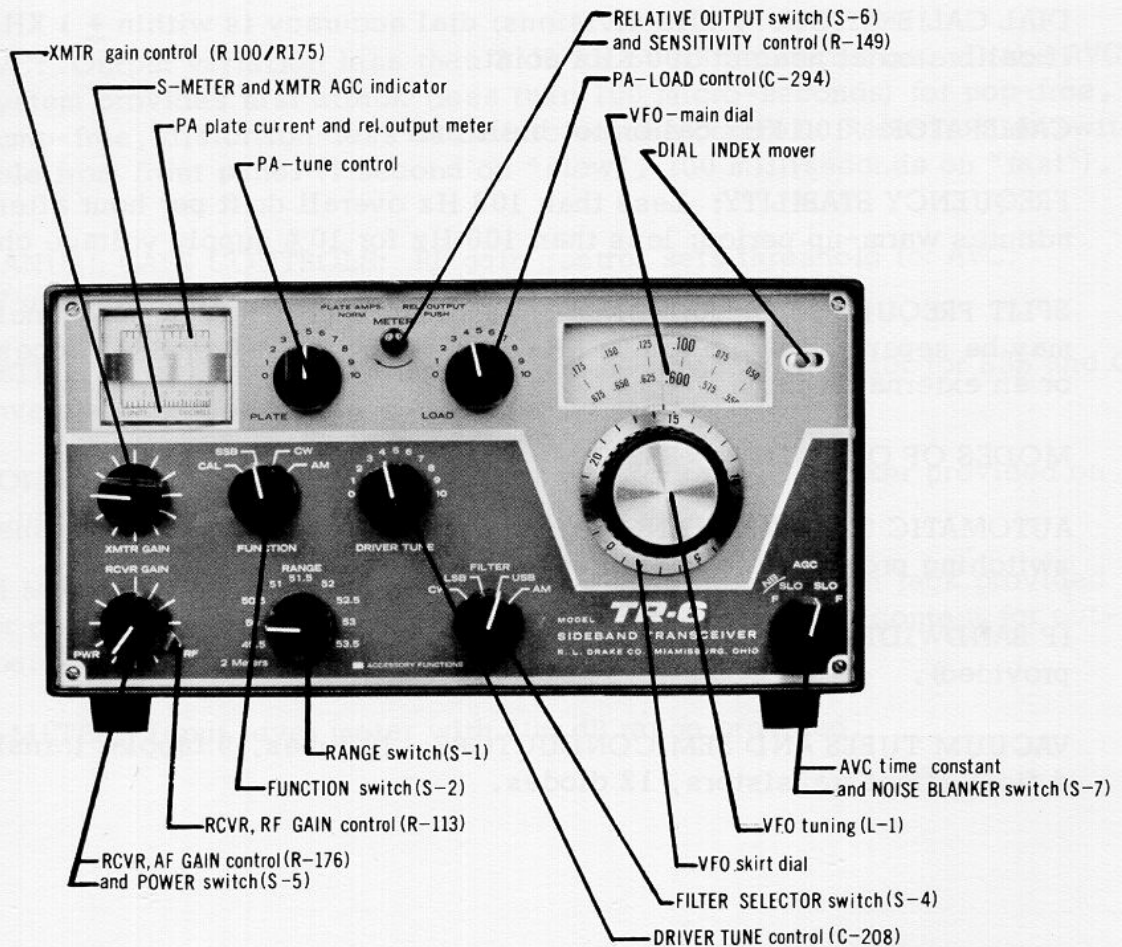

FIG. 1—FRONT VIEW

I. GENERAL DESCRIPTION

The R.L. Drake model TR-6 is a radio transceiver which, in conjunction with an external fixed or mobile power supply and a suitable antenna, permits two way radio communications on any frequency in the 6 meter amateur band as well as on adjacent frequencies.

The mode of transmission and reception is switchable. The unit is capable of communicating in the SSB, AM, FSK, and keyed CW modes. Appropriate modulators and detectors are provided for each mode, as well as switching for appropriate IF filters.

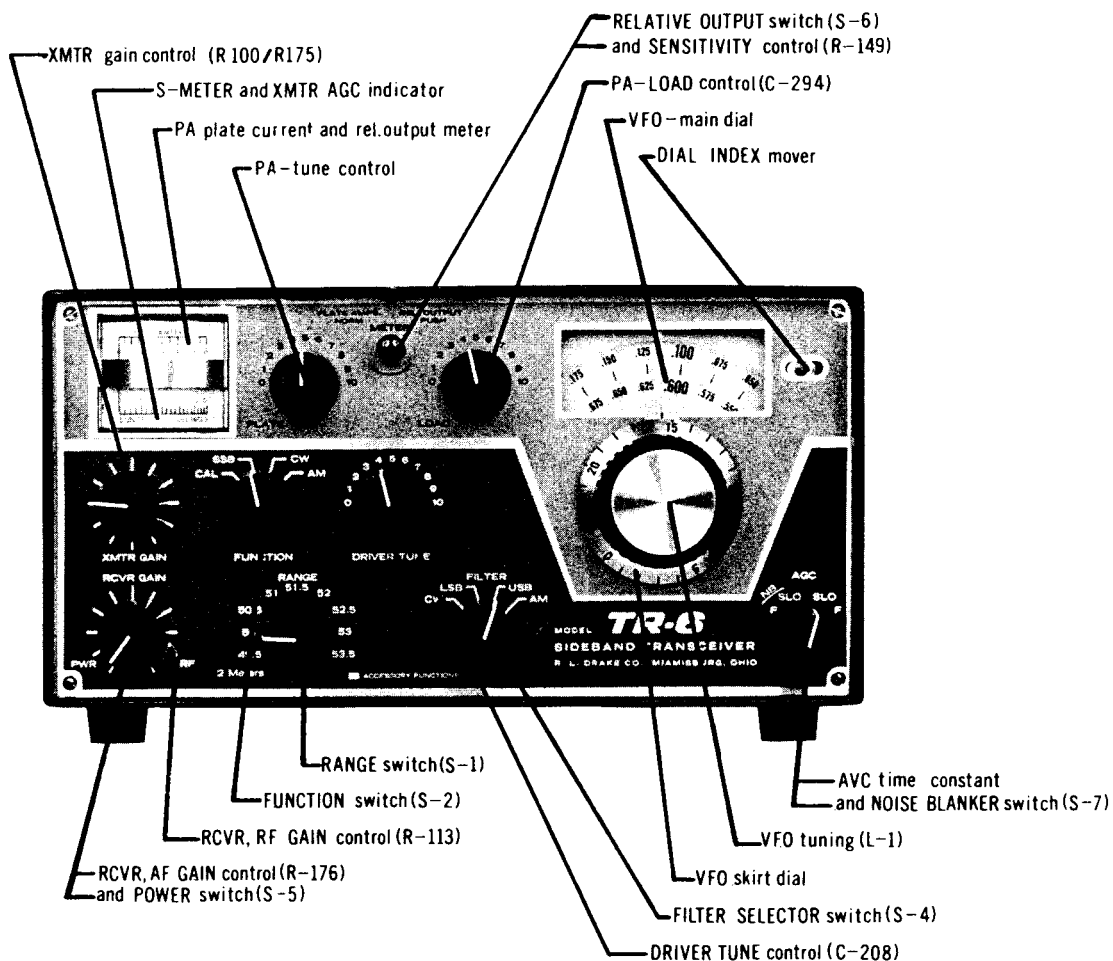

FIG.1-FRONT VIEW

II. SPECIFICATIONS

A. GENERAL SPECIFICATIONS

SIZE: 5 - 7/16" high, 10 - 3/4" wide, 14 - 1/4" deep (cabinet without feet and knobs).

WEIGHT: 15 - 3/4 lbs.

FREQUENCY COVERAGE: 49.4 to 54.0 MHz in 9 overlapping 600 KHz ranges (49.9 to 51.0 MHz with crystals supplied).

FREQUENCY ADJUSTMENT: Solid state linear permeability tuned VFO permits continuous frequency coverage.

DIAL CALIBRATION: 1 KHz divisions; dial accuracy is within ± 1 KHz if calibrated at nearest 100 KHz point.

CALIBRATOR: 100 KHz calibrator built in.

FREQUENCY STABILITY: Less than 100 Hz overall drift per hour after 15 minutes warm-up period; less than 100 Hz for 10% supply voltage change.

SPLIT FREQUENCY OPERATION: Transmitting and receiving frequencies may be separated by up to 600 KHz by use of the RV-6 or FF-1 accessories or an external receiver.

MODES OF OPERATION: SSB, AM, and CW.

AUTOMATIC T/R SWITCHING: With multi-contact relay. Front panel switching provided for 2m-transverters.

IF BANDWIDTHS: 4 filters switchable from front panel (USB filter provided).

VACUUM TUBES AND SEMICONDUCTORS: 19 tubes, 9 bipolar transistors, 4 field effect transistors, 12 diodes.

B. RECEIVER SPECIFICATIONS

SENSITIVITY: Less than 1/10 microvolt for 10 dB S+N/N ratio at 2.4 KHz bandwidth.

SELECTIVITY: 6 dB bandwidth 2.4 KHz nominal. 50 dB bandwidth 7 KHz maximum, with USB filter provided. Accessory filters, switchable from front panel available for LSB, AM (6 KHz at 6 dB), and CW (.3 KHz at 6 dB).

AUDIO RESPONSE: 400 to 2800 Hz at 6 dB.

INPUT: 50 ohms unbalanced.

OUTPUT: 4 ohms unbalanced, speaker and headphone output provided.

OUTPUT POWER: 2 watts at 10% HD.

AVC: Output variation less than 3 dB for 60 dB input change. Drake AVC system provides fast attack (less than 100 micro-seconds) for pop-free, pump-free, distortion-less automatic volume control. Release time switchable from front panel (1 second on "slow", 200 milliseconds on "fast").

MANUAL GAIN CONTROLS: RF gain control sets threshold for AVC; AF gain control.

DETECTORS: Switchable from front panel. Product detector for SSB and CW, envelope detector for AM.

NOISE BLANKER: On-off switch for accessory noise blanker provided on front panel.

14 MHz INPUT: 13.9 to 14.5 MHz receiving input/output jack provided for converters and/or outboard IF receivers. T/R muting contact for outboard receiver provided.

S-METER: Input level meter with 100 dB range provided.

C. TRANSMITTER SPECIFICATIONS

POWER INPUT: 300 W minimum PEP on SSB, 300 W PEP (75 W peak carrier compatible with SSB amplifiers) on AM. 260 W CW.

OUTPUT IMPEDANCE: 50 ohms nominal, unbalanced, 2:1 maximum SWR, loading adjustable from front panel.

MODES: SSB (upper sideband provided, lower sideband with accessory filter) AM (controlled carrier screen modulator built in). CW (grid block keying shaped for click free keying). Modes selectable with front panel switch.

AGC: Amplified automatic gain control prevents flat-topping and provides moderate speech compression in the SSB mode.

CARRIER INSERTION AND SHIFT: Automatic carrier insertion on AM, shift carrier system on CW.

INPUTS: Closed circuit type key jack for CW; high impedance high level microphone input on SSB and AM, 3 mv peak RMS minimum required for full PEP output. Manual gain control for CW and SSB/AM provided on front panel.

VOX AND PTT: VOX and ANTI-VOX built in. Separate VOX and ANTI-VOX gain controls provided. PTT contact provided on microphone jack. VOX also effective on AM and keyed CW, providing automatic semi break-in CW.

AUDIO RESPONSE: 400 to 2800 Hz at 6 dB.

CARRIER AND SIDEBAND SUPPRESSION: 40 dB minimum sideband suppression above 1 KHz. 50 dB minimum carrier suppression.

DISTORTION PRODUCTS: Down 30 dB minimum from PEP level.

MONITORING AND METERING: Final plate current, AGC action, and relative output can be read on meters. Sidetone with separately adjustable volume provided for keyed CW.

14 MHz OUTPUT: 13.9 to 14.5 MHz transmitting output for 2m-transverter.

D. POWER REQUIREMENTS

1. 650 volts DC at .5 A maximum with good regulation.
2. 250 volts DC at .175 A with low ripple.
3. -60 volts adjustable into 30 K load.
4. 12.6 volts at 5.5 A continuous.

The R. L. Drake models AC-3 and AC-4 power supplies (for 115/230 volt AC input 50 to 400 Hz), as well as the DC-3, DC-4, and DC-24 (for 12 volt or 24 volt, respectively, DC input), provide all necessary voltages for the operation of the TR-6.

III. UNPACKING

Carefully remove your TR-6 from its packing carton and examine it closely for signs of shipping damage. Should any be apparent, notify the delivering carrier immediately, stating the full extent of the damage.

Fill out and mail the enclosed registration card so that your warranty will be effective.

Save the packing material. You may need it later for reshipment or storage.

Inspect the packing material closely before putting it away to be sure you have not overlooked the Switchcraft type S-230 and 229 plugs and other hardware shipped with the TR-6.

Before starting to install and operate your TR-6, you should familiarize yourself thoroughly with the functions of the different controls as described in the next section.

IV. MANUAL CONTROLS AND JACKS

A. FRONT PANEL CONTROLS (see figure 1)

1. MAIN TUNING - The main tuning knob of the TR-6 determines the frequency on which the TR-6 transmits and receives. Each division around the calibrated skirt on this knob is equal to 1 KC and each each division on the main tuning dial is equal to 25 KC. The small red knob just to the right of the dial scale is provided for adjusting the position of the indicator line for calibration. The knob skirt is also adjustable by pushing it in slightly and rotating it in the desired direction, while holding the main tuning knob stationary.
2. RCVR GAIN - The RCVR GAIN control consists of two controls with concentric shafts. The lever controls the maximum RF gain of the receiver by varying the amount of negative bias applied to the grids of the AGC controlled tubes and transistor.

The knob adjusts the audio gain by regulating the input to the grid of the audio power amplifier tube. The transceiver power switch is operated at the extreme counter clockwise end of rotation of this knob.

3. XMTR GAIN - This control regulates the microphone gain on AM and SSB. When the unit is operated on CW, it is used to adjust the RF drive to the proper level.

This control is connected so that it regulates the VOX sensitivity as well as the audio drive to the balanced modulator. Since all changes in level due to the type mic, how close or loud you talk, etc., affect equally the VOX and audio drive requirements, this eliminates the necessity for changing the VOX gain control, located on the side of the TR-6 chassis, once it is set properly.

4. FUNCTION - The FUNCTION SWITCH is a four-position switch which determines the mode of operation of the TR-6.

In the SSB position, the receiver portion functions until the transmitter is energized either by talking into the microphone or pressing the push to talk switch.

In the CAL position, the 100 KC crystal calibrator is switched on for calibration purposes. The receive and transmit functions operate the same way as in the SSB position.

The FILTER switch must be in either the USB or LSB position, depending on which sideband is desired.

Note that a CW key, if used, must be either closed or unplugged to obtain RF-output on SSB.

In the CW position, the receiver portion functions until a key plugged into the key jack, is closed. The TR-6 then goes into the transmit mode, a CW sidetone is energized, and the carrier is shifted up by 1 KHz from the receiver zero beat frequency. It will remain on transmit during CW keying and will return to receive when keying is stopped briefly.

Note that no RF output will be obtained on CW or AM when the lower sideband filter is switched in.

On the AM position, a controlled carrier screen modulator is incorporated for AM transmission, and a diode detector is incorporated for AM reception. Transmit/receive switching is accomplished by VOX or PTT as on SSB.

5. RANGE - The RANGE switch is a ten position switch which selects the desired segment of the band.

Note that only the ranges 50 (covering 49.9 to 50.5 MHz) and 50.5 (covering 50.4 to 51.0 MHz) can be covered with crystals supplied. All other ranges require appropriate plug-in accessory crystals (see Section XII).

In the last counter-clockwise position of the RANGE switch (labeled "2 meters"), the 50 MHz section of the transceiver is disabled. 14 MHz VIF input and output jacks are provided for the R.L. Drake model SC-2 converter and 2 m-transverters.

6. PLATE - The PLATE control tunes the power amplifier pi-network circuit to resonance by varying the input capacity.
7. DRIVER TUNE - This control peaks the driver plate circuit coil.
8. LOAD - The LOAD control matches the impedance of the transceiver power amplifier to the impedance of the load by varying the output capacity of the pi-network circuit.
9. FILTER - The FILTER switch selects the upper or lower sideband filters for SSB, or the AM or CW filters.

Please note that only the USB filter is supplied with the unit. AM and CW transmitting and receiving can be done with this filter, although the accessory AM and CW filters provide bandwidths more adequate for receiving these modes. The LSB accessory plug-in filter is necessary for transmitting and receiving lower sideband signals.

10. AGC - The AGC switch allows you to change the release time constant of the receiving AGC (also called AVC). In the two counter-clockwise positions of this switch the noise blanker, if installed, is activated.
11. OUTPUT METER CONTROL - This control consists of a push switch and potentiometer. Pushing in converts meter from plate amperes to a relative output indicator and rotating varies the sensitivity of this indicator.
12. S-METER - The S-METER indicates relative signal strength of the received signal. It is calibrated in S-units from S-1 to S-9 and in dB over S-9. Each S-unit equals approximately 5 dB and S-9 equals about 10 microvolts. On transmit, it indicates the point at which the transmitting AGC starts, to help in setting the proper level of the XMTR GAIN control.
13. PLATE AMPERES - The PLATE AMPERES meter indicates plate current in the final amplifier tubes, and relative RF output.
14. PTO INDICATOR LAMP - The PTO INDICATOR LAMP (mounted directly above the main tuning knob) lights only while the TR-6 PTO is functioning. For example, when using the RV-6 with its function switch in "RVC" and transmitting with the TR-6, the indicator lamp lights on "transmit". The RV-6 indicator lamp lights whenever the TR-6 lamp does not.

B. SIDE CONTROLS AND JACKS (front to rear)

1. PHONES - The headphone jack automatically disconnects the speaker when the headphones are plugged in. The audio output impedance at the jack is 4 ohms.

Headphones with any impedance may be used. Headphones with a medium impedance (like 500 ohm) will be found most suitable. A speaker may be plugged in here instead of connecting it to the power connector if so desired.

A Switchcraft type 229 plug (red) is supplied with the TR-6 which can be used either here or at the KEY jack.

2. MIC - This is a .210-inch diameter phone jack of the three conductor variety to accommodate microphones with push to talk switches. It requires a Switchcraft type S-230 plug which is supplied with your TR-6.
3. VOX - The VOX control adjusts the gain of the VOX amplifier, and relay release time on CW.
4. ANTI-VOX - The ANTI-VOX control adjusts the sensitivity of the ANTI-VOX system.
5. ZERO - The S-Meter ZERO control is provided for adjusting the no signal reading of the S-Meter to S-1.
6. KEY - The KEY jack is of the normally closed variety. The key, if plugged in, allows keyed CW operation (A-1).

Note that plugging a key into this jack will disable the transmitter on all modes and the receiver on AM unless the key is closed.

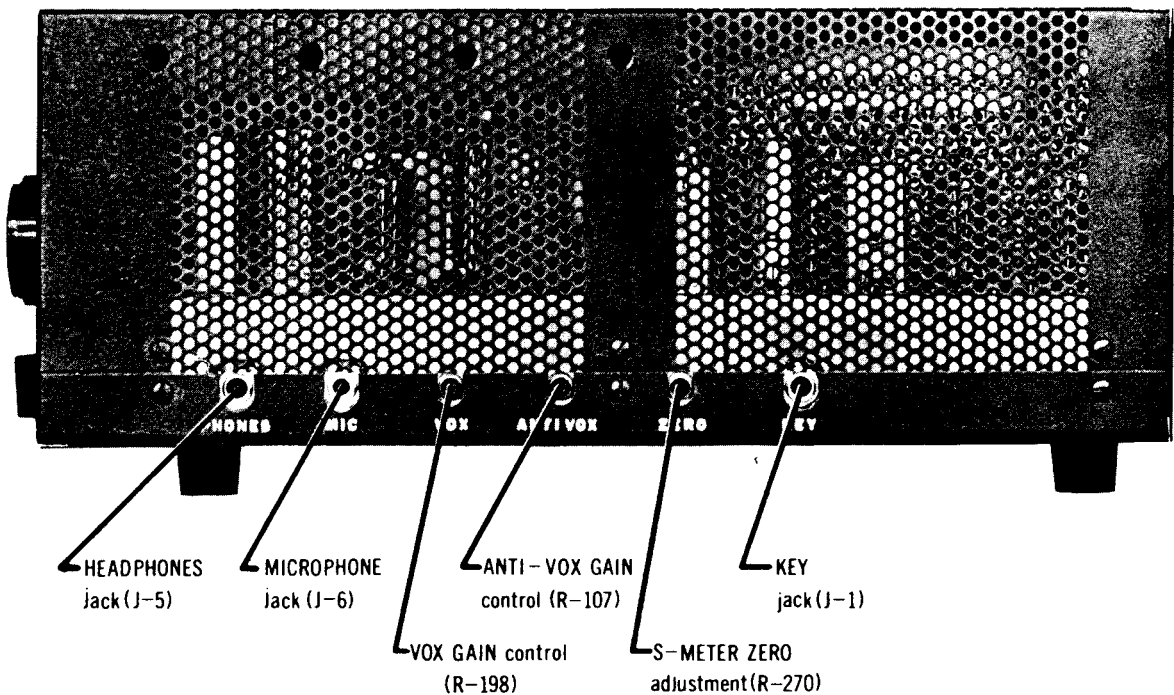

FIG.2 - SIDE VIEW

C. REAR CONTROLS AND JACKS

1. **LIGHTS** - The **LIGHTS** switch is a two position slide switch which is used to control the brilliance of the dial lights. The letters D and B indicate dim and bright respectively.
2. **CARRIER BALANCE** - The **CARRIER BALANCE** control is a potentiometer located on top of the chassis along the rear edge and is provided for balancing the balanced modulator.

Note that this control has a planetary drive and requires 10 1/4 turns for complete travel.

3. **SIDETONE** - The **SIDETONE** control, located on the rear of the chassis, controls the volume of the CW sidetone with respect to the received signal. If no sidetone is desired, rotate the **SIDETONE** control fully counter-clockwise.
4. **MUTE** - The **MUTE** jack provides a means of muting an external receiver without an external relay. It provides DC path to ground on receive and may be used with Drake 1-A, 2-A, 2-B, 2-C, R-4, R-4A, and R-4B receivers.
5. **CONV JACK** - The **CONV JACK** connects to the 14 MHz variable IF system of the TR-6. It permits the use of the TR-6 with an outboard receiver tuning from 13.9 to 14.5 MHz. This jack also permits reception with Drake SC-6 or SC-2 converters or other converters having a 13.9 to 14.5 MHz IF output. The TR-6 receiving converter may be disabled by placing the range switch in the "2 Meters" position. Otherwise two frequencies, possibly in different bands, may be monitored at the same time.
6. **TRSV JACK** - The **TRSV JACK** provides output for transverters requiring 13.9 to 14.5 MHz input. When using the TR-6 with a transverter, the **RANGE** switch on the TR-6 should be placed in the "2 Meters" position to disable the TR-6 50 MHz stages.
7. **POWER JACK** - The 12 position male **POWER JACK** fits the output plug of Drake DC-3, DC-4, DC-24, AC-3, and AC-4 power supplies.
8. **SCREEN JACKS** - The **SCREEN JACK** provides modulated screen voltage for transverters.

CAUTION: +250 volts DC is present on the center terminal of this jack.

9. GROUND - A stud is provided near the left edge of the rear of the TR-6 chassis for connecting the transceiver to ground, if available. Use a short, heavy wire. This stud must also be used for joining the TR-6 to the RV-6 chassis is used.
10. ANTENNA - An SO239 connector connects the TR-6 to the antenna system.

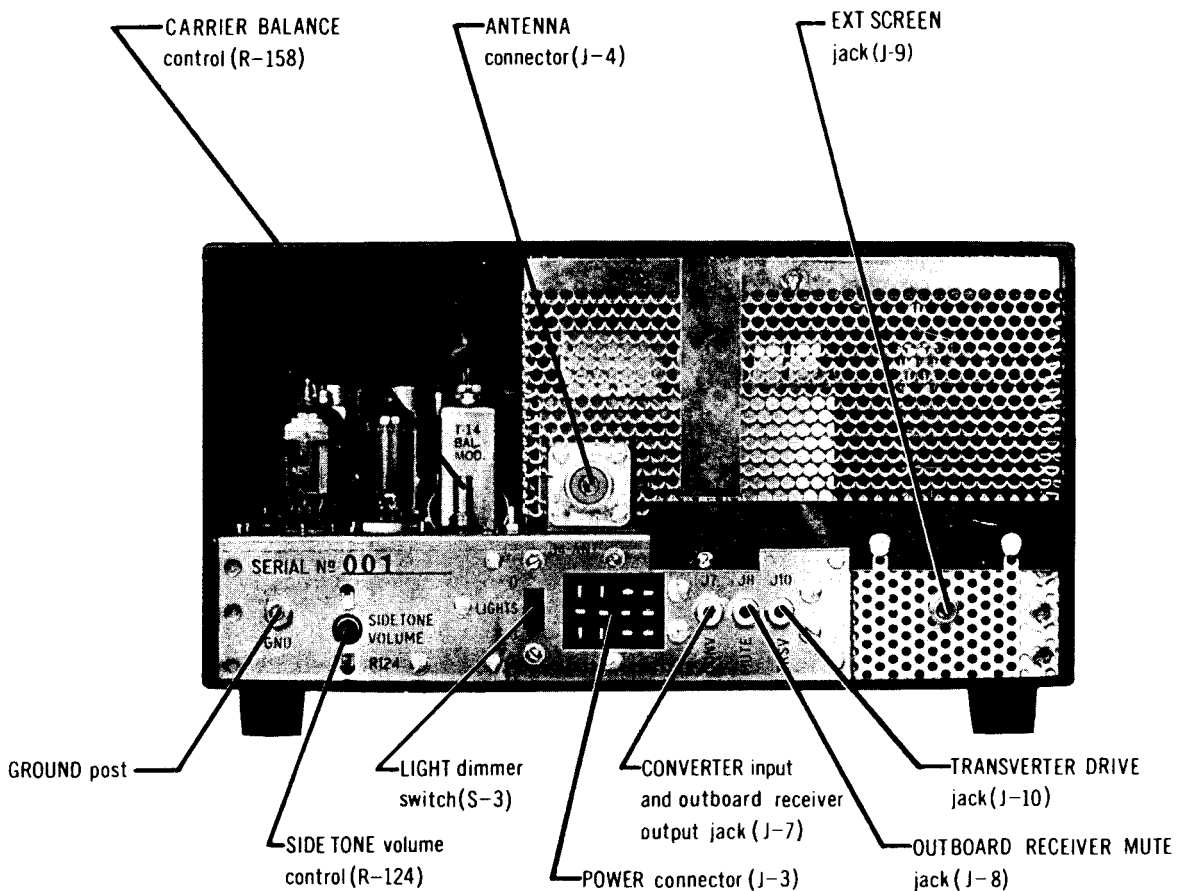

FIG.3 - REAR VIEW

V. INSTALLATION

A. ANTENNA REQUIREMENTS

The TR-6 is designed to work into RF loads with a nominal impedance of 50 ohms.

The SWR should not exceed 2:1 with respect to 50 ohms. For detailed discussions of antennas and feedlines, refer to a good VHF antenna manual.

Antenna connection to the TR-6 is provided at the SO-239 coax connector located on the rear of the shielded compartment housing the final amplifier components.

CAUTION: NEVER ATTEMPT TO OPERATE THE TR-6 WITHOUT FIRST CONNECTING IT TO AN ANTENNA OR 50 OHM DUMMY LOAD OF SUFFICIENT POWER HANDLING CAPABILITY OR SERIOUS DAMAGE CAN RESULT.

B. POWER REQUIREMENTS

Refer to section II, paragraph D, for power requirements.

C. SPEAKER AND HEADPHONES REQUIREMENTS

Although the TR-6 is designed to put out maximum audio power into a 4 ohm load, headphones with higher impedance may be used with good results.

The Drake model MS-4 speaker is designed as a matching speaker for all Drake receivers and transceivers and perfectly meets all requirements for TR-6 speakers. The speaker connects to terminals 7 and 12 (pin 7 grounded) of the TR-6 power jack (J-3). A female phone-plug is connected to these terminals on the output plug on the Drake power supplies to allow easy speaker hook-up. The speaker may also be connected to the headphones jack (J-5) if so desired.

A Switchcraft S-239 plug to fit the headphones jack is shipped with the TR-6.

D. KEY AND MICROPHONE REQUIREMENTS

1. KEY - The Switchcraft S-239 plug also fits the key jack (J-1). Key shaping and suppression networks in parallel with the key contacts

(as used on older keys made for cathode keying), must be removed. Electronic keyers must be connected for grid block keying.

2. MICROPHONE - The TR-6 is designed for use with a high-impedance, high-output microphone (ceramic or crystal).

A microphone with a wide and flat frequency response will enable you to obtain peak performance from your TR-6. For good VOX (voice control) operation, it is desirable for the mike to have a cardioid pattern to reduce pickup from the back and sides. This enables you to operate with higher receiver audio gain, giving better VOX operation and reducing echoes, reverberation, and noise pick-up in the fixed or mobile installation. Microphones with limited low or high frequency response and with peaks in the voice range should be avoided.

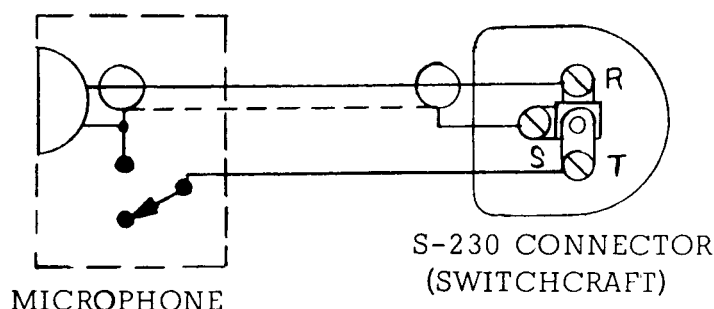

Fig. 4

A three conductor microphone plug (Switchcraft type S-230) is provided with the TR-6. The microphone must be connected as shown in fig. 4 for proper VOX and push-to-talk operation. Many microphones that are furnished with a switch are wired so that the microphone cartridge is open or short circuited unless the switch is depressed. This function must be defeated or VOX operation will be impossible.

The Drake 729 SRD microphone is available at a reasonable price and comes properly wired to the plug. It has a high impedance output and cardioid pattern.

E. LOCATION

In general, the location of the TR-6 is not critical, either in fixed or mobile installations. However, care should be taken to insure that space is allowed around the unit to allow adequate air circulation.

Extremely hot locations, such as near radiators or heating units, should be avoided. Do not cover the top of the TR-6 with books, papers, or pieces of equipment or overheating may result.

F. FIXED INSTALLATION

For fixed installation, our models AC-3 or AC-4 115/230 VAC 50/60 Hz power supplies will be required, and the model MS-4 matching speaker is highly desirable. Connect these units as shown in figure 7.

Note that the AC-4 power supply will fit inside the MS-4 cabinet to form one compact unit.

G. MOBILE INSTALLATION

The TR-6 may be installed in any vehicle having a 12 or 24 VDC electrical system. Our models DC-3, DC-4, or DC-24 power supplies will be required for this installation. All DC-3, DC-4, and DC-24 power supplies are factory wired for negative ground systems.

IF YOUR VEHICLE HAS A POSITIVE GROUND SYSTEM, DO NOT ATTEMPT TO CONNECT THE DC POWER SUPPLIES OR SERIOUS DAMAGE WILL RESULT.

1. Mount the TR-6 in a convenient location under the dash using the MMK-3 mobile mounting kit. See MMK-3 instruction sheet for more detailed instructions on various suggested mounting methods. Be sure to allow adequate clearance for air circulation and at the right side for access to the screw driver adjustments and the mike jack.
2. The recommended mounting position for the DC power supplies is on the passenger side of the firewall. We do not recommend that it be placed in the trunk due to the excessive primary lead length or in the engine compartment unless it is protected from water and engine heat.

Make sure that the on-off switch on the TR-6 is in the off position (audio gain fully counter-clockwise until a click is heard), and connect the female power connector on the end of the power cable to the TR-6. Coil up excess cable and tape in an out-of-the-way location. You may need the extra length when you trade cars. Run the black wire from the power supply to a convenient ground and run the red wire through the firewall to the battery terminal of the starter relay. Shorten the heavy red and black wires as much as possible.

3. Install a mobile antenna in the manner recommended by the antenna manufacturer and connect the coax lead from it to the SO-239 connector of the TR-6 (see figure 6). The use of a directional RF wattmeter, Drake W-4 or WV-4, is recommended.
4. If your car has a transistor radio, we suggest you install a separate speaker for use with the TR-6. However, if the radio in your car has a vacuum tube audio amplifier, and if one side of its speaker is grounded, run a wire from the ungrounded terminal to the center conductor of a male phone plug. Insert this plug in the female jack molded into the end of the 6 inch wire protruding from the connector on the end of the DC-4 power cable. It should be unnecessary to disconnect the auto radio output transformer when the TR-6 is used, unless it has insufficient volume. If this proves to be the case, a SPDT switch can be installed so that the speaker lead goes to the pole, the car radio output goes to one contact, and the TR-6 output goes to the remaining contact.
5. For information on noise suppression, consult the mobile noise suppression section of the ARRL Radio Amateur's Handbook.

H. INSTALLATION WITH OTHER ACCESSORIES

1. LINEAR AMPLIFIER - Refer to the manual of the amplifier in use. If the amplifier has AGC output (sometimes called ALC), it should be connected to pin 3 of the power jack (J-3) of the TR-6. The use of shielded wire is recommended. The AC-4 power supply has an AGC jack installed for this purpose.
2. REMOTE VFO - The cable from the RV-6 connects to J-2 of the TR-6. Refer to the instruction sheet of the RV-6.
3. CRYSTAL CONTROL UNIT - The FF-1 plugs into the RV-6 socket of the TR-6. Refer to the FF-1 instruction sheet.
4. TRANSMITTING AND RECEIVING CONVERTERS - IF input and output jacks as well as a screen supply output for transverters are provided in the rear of the TR-6. For hook-up, refer to the respective manuals.
5. NOISE BLANKER - A socket (J-11) for plugging in the cable coming from a noise blanker is located in top of the TR-6 chassis. Save the dummy plug that is plugged into J-11. For installation of the noise blanker, follow the instructions that are included with the unit.

I. USE IN AIRCRAFT

Amateur radio equipment, when used in aircraft, does not require FAA Type Approval because it is not the primary means of aircraft communication. However, airborne amateur equipment must be installed by a certified mechanic or the installation approved by FAA Local Inspection.

We suggest you contact the local FAA General Aviation District Office before any installation is attempted.

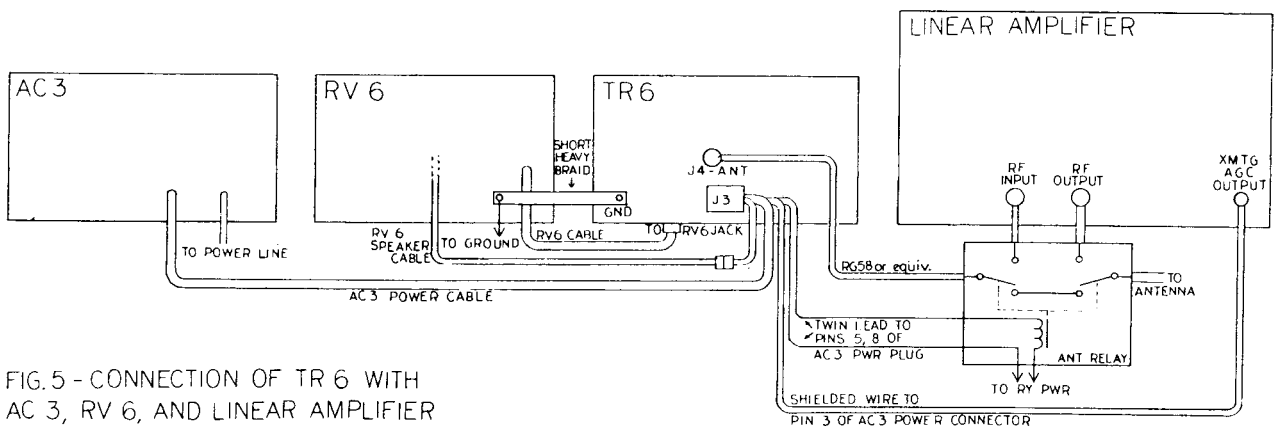

FIG.5 - CONNECTION OF TR 6 WITH AC 3, RV 6, AND LINEAR AMPLIFIER

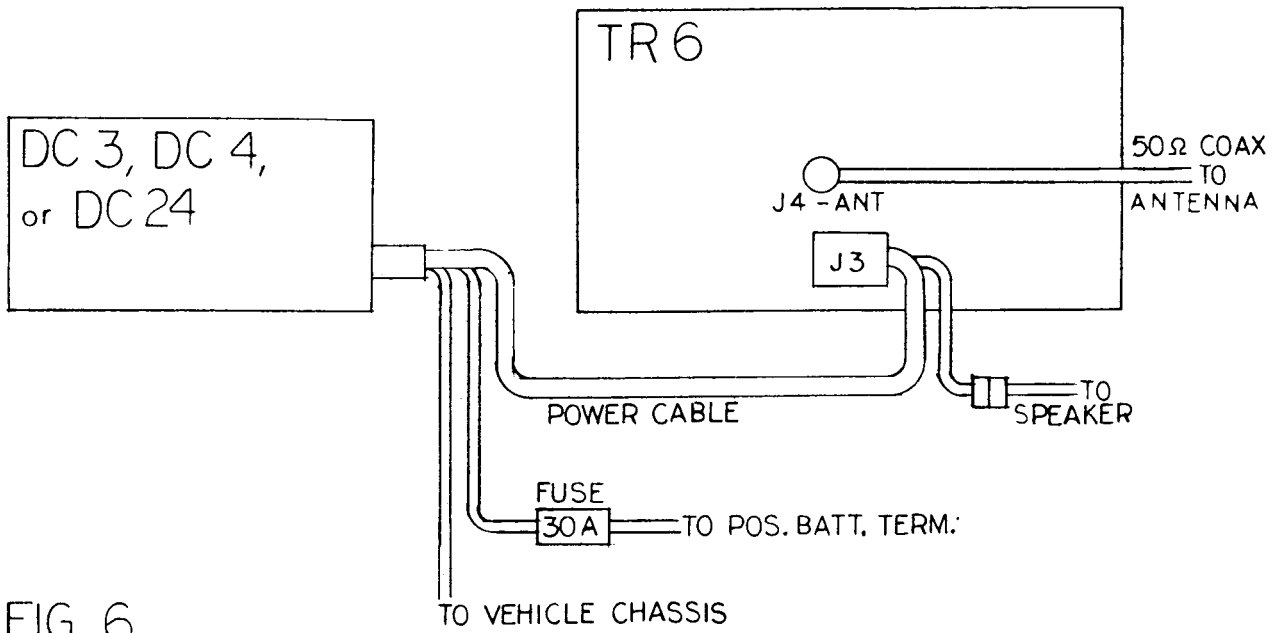

FIG. 6
MOBILE INSTALLATION OF TR 6

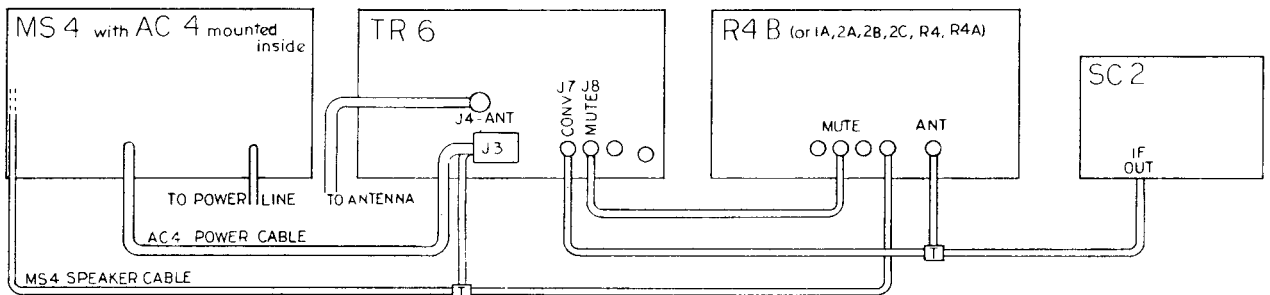
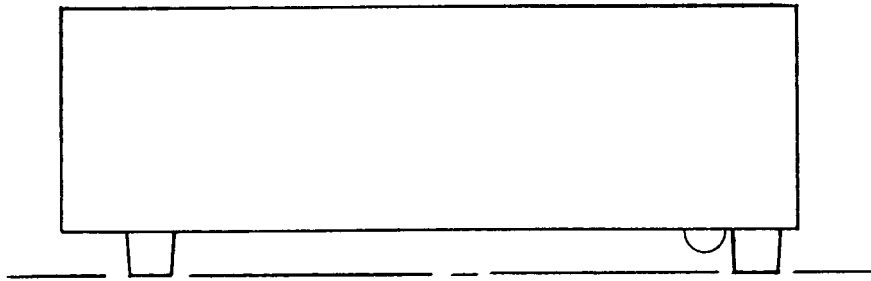

FIG. 7- CONNECTION OF TR 6 WITH AC 4, MS 4, SC 2, AND AN EXTERNAL RECEIVER

VIEWING ANGLE OPTIONS

FIGURE 8



STANDARD

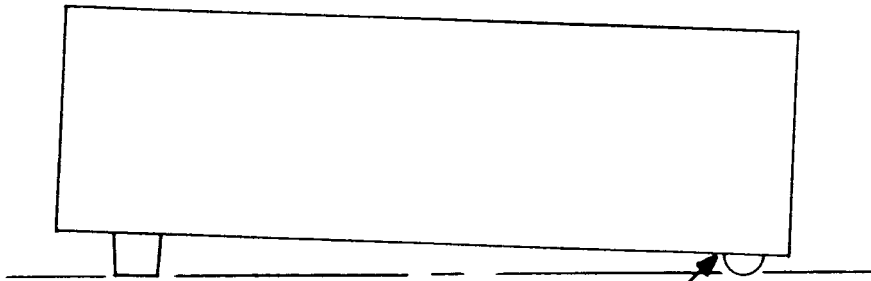

OPTION # 1

SCREW MOUNTED REAR
FEET REMOVED

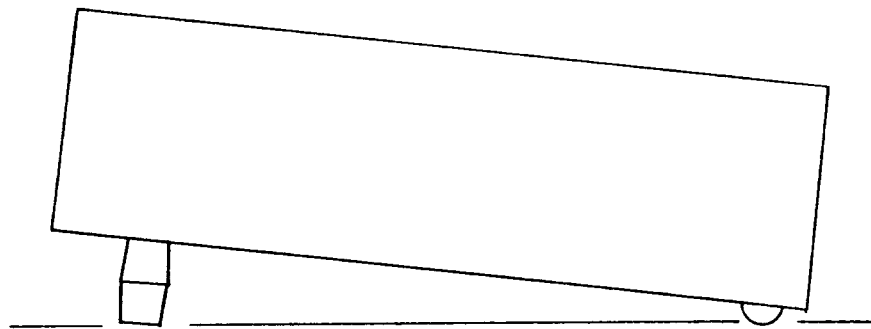

OPTION # 2

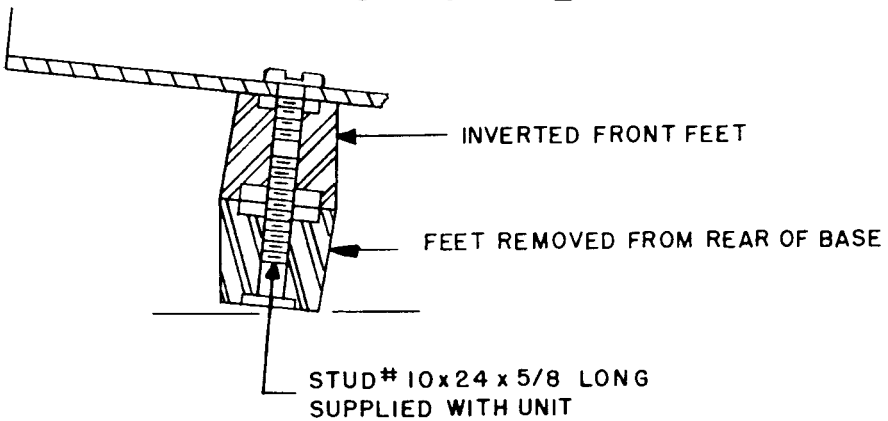

VI. TUNING PROCEDURE

WARNING: UNDER NO CIRCUMSTANCES SHOULD OPERATION OF THE TR-6 BE ATTEMPTED UNLESS IT IS CONNECTED TO PROPER ANTENNA OR A DUMMY LOAD OF SUFFICIENT POWER HANDLING CAPABILITY.

A. BIAS ADJUSTMENT

Before any type of operation is attempted, it will be necessary to set the power supply bias adjustment as described here.

1. Turn on TR-6 by rotating RCVR GAIN control knob clockwise.
2. Let the unit warm up for at least 15 minutes.
3. Rotate XMTR GAIN control fully counter-clockwise.
4. Turn SIDEBAND switch to the LSB position.
5. Turn function switch to CW.
6. Adjust the bias adjustment on the power supply for a reading of .1 on the plate amperes meter. This completes the adjustment.

B. ADJUSTING DIAL CALIBRATION

The calibration of the main tuning dial on the TR-6 may vary slightly from range to range due to the tolerance limits of the various crystals. Therefore, the main tuning dial index has been made adjustable by means of the small red knob to its right. To set the calibration on a given band, proceed as follows:

1. Set XMTR GAIN fully counter-clockwise.
2. Set FUNCTION switch to CAL.
3. Set RANGE SWITCH to desired range.
4. Zero beat the 100 KC calibrator signal nearest the desired operating frequency.
5. Slide the red knob to the right of the dial scale until the index line coincides with the 100 KC dial calibration.
6. While holding the main tuning knob, push in on its calibrated skirt and rotate it until the zero coincides with the indicator line.

C. TUNE-UP ON THE DESIRED RANGE

The CW position of the function switch is used for tuning up the transmitter. The key jack is a closed circuit type jack so it is not necessary to plug in a key for tune up.

WARNING: DO NOT ALLOW THE PLATE CURRENT TO EXCEED .1 AMPS FOR MORE THAN 5 OR 6 SECONDS IF THE PLATE CONTROL IS NOT TUNED FOR PLATE CURRENT DIP OR MAXIMUM R.F. OUTPUT. Failure to observe this warning will result in rapid final amplifier tube deterioration due to excessive plate dissipation.

Note that the final amplifier pi-network will match a 50 ohm load with VSWR no higher than 2:1. It may be found necessary to use an external antenna tuning network or change the feed line by 1/8 to 1/4 wave length to get the proper match.

1. Preset the controls as follows:

RANGE SWITCH to desired range.
FREQUENCY knob to or near frequency desired.
XMTR GAIN fully counter-clockwise.
LOAD to "4".
FILTER to USB.
FUNCTION switch on SSB.
DRIVER TUNE to "5".

2. Rotate the function switch to the CW position and advance the XMTR GAIN control clockwise until the plate amperes meter moves up scale slightly from idling current. (If plate current is high even with XMTR GAIN fully counter-clockwise, reduce it to idling by adjusting CARRIER BALANCE control (see section D), after the tune-up has been performed.)
3. Depress the OUTPUT METER CONTROL and rotate it for a significant indication on the plate amperes meter. (This control converts the plate amperes meter to a relative output indicator and varies its sensitivity.) Tune the PLATE control for maximum RF output. Peak the DRIVER TUNE control for maximum RF output.
4. Rotate the XMTR GAIN control clockwise until plate current no longer increases. (This point should be found well before the knob reaches the 12 o'clock position.)

Alternately adjust LOAD and PLATE controls in small increments for maximum RF output. If meter goes off scale during this process, simply reduce its sensitivity by turning the output meter control counter-clockwise.

At this point, the plate current should read between .350 and .500 amps depending upon supply voltage, antenna match, drive, tube condition, etc. Do not attempt to increase the LOAD control beyond the point at which maximum RF output occurs or excessive plate dissipation will result.

It should not be necessary to advance the LOAD control beyond 7-1/2 to obtain maximum RF output. Further advancement indicates that the SWR of the antenna system is too high and leaving the control set beyond this point is likely to result in excessive harmonic radiation.

The above procedure should be completed as quickly as possible and the function switch should be returned to the SSB position.

D. ADJUSTMENT OF CARRIER BALANCE CONTROL

The CARRIER BALANCE control is factory adjusted and should not require resetting under most conditions. However, it should be checked before the TR-6 is operated on SSB.

The carrier suppression provided by the crystal filters on SSB is sufficiently great that it will be impossible to adjust the balanced modulator for optimum attenuation in this mode unless a sensitive RF detector (receiver) is used in close proximity to the transceiver. We therefore recommend that balanced modulator adjustment be performed in the CW mode since the filters are not effective here. The balanced modulator should be adjusted after the unit has warmed up for about 1/2 hour in order to maintain optimum balance over a prolonged period of time.

After tuning up the TR-6 as described above, set the filter switch to "USB", the XMTR GAIN fully counter-clockwise, and the FUNCTION switch to CW. Now depress OUTPUT METER CONTROL and adjust the CARRIER BALANCE control (located on top of the chassis near the rear edge) for zero RF output. If output cannot be reduced to zero, adjustment of the carrier balance capacitor may be necessary, (see section X). Return the FUNCTION switch to SSB. This completes the adjustment.

Some residual signal will occasionally be observed on the CW mode when the XMTR GAIN control is set at minimum. This is of no consequence since the additional attenuation provided by the filters on SSB will provide the desired carrier suppression.

VII. OPERATION

In the following discussion, it is assumed that the TR-6 has already been tuned up on or near the desired frequency as described under tuning procedures.

A. VOICE CONTROLLED OPERATION ON SSB

Preset the controls as follows:

FILTER on USB (or LSB if the lower sideband is desired and the LSB filter has been installed).

FUNCTION SWITCH on SSB.

XMTR GAIN fully counter-clockwise.

RF GAIN fully clockwise.

AF GAIN fully counter-clockwise (do not turn off power).

VOX GAIN fully clockwise.

ANTI VOX fully counter-clockwise.

While talking into the microphone in a normal voice, increase the XMTR GAIN control until the S-meter starts kicking up scale about 2 or 3 S-units above its resting value. (With no modulation, the S-meter will rest from about S-5 to S-9 on transmit.) This indicates that the transmitting AGC is starting to work and the transmitter is peaking at maximum output. Continue talking and reduce the VOX GAIN until a point is reached where further reduction results in too frequent relay drop-out.

Now increase the AF GAIN until received signals are of the desired volume. This may cause the transceiver to cycle back and forth between transmit and receive. Adjust the ANTI VOX control until this cycling stops. You are now ready to operate.

B. PUSH TO TALK OPERATION ON SSB

If the push to talk switch on your microphone is properly connected as described in section V, D, it may be depressed at any time, thus over-riding the VOX system.

If you do not desire the VOX to function at all, turn the VOX gain control fully counter-clockwise.

REMEMBER: On SSB, the TR-6 transmits on exactly the same frequency on which it receives. Therefore, be sure that before you answer another station's CQ, or break another QSO, you have the signals tuned in so that the voices sound normal. Otherwise, you will not be transmitting exactly on frequency.

Note if a key is used, it must either be closed or unplugged from the key jack for SSB and AM operation.

C. CW OPERATION

To work CW, plug your key into the KEY jack. If an electronic keyer is used, connect it for grid block keying. Leave the key in the open condition.

Note that the TR-6 uses shifted carrier CW. With this system, it is possible to transmit approximately on the received station's frequency without being zero beat while receiving. The receiver BFO is shifted from the transmitted signal frequency about 1 KHz.

To receive CW signals, place the function switch on the CW position and the filter switch in the USB position (CW position if a CW filter has been installed). Tune in a CW signal for an audio pitch of about 1 KHz and adjust the audio gain control for pleasing volume.

To transmit, depress the key, and rotate the XMTR GAIN control clockwise just below the point at which plate current no longer increases. DO NOT ADVANCE IT BEYOND THIS POINT.

Advance the SIDETONE control on the rear of the chassis until the sidetone reaches the desired volume. (Adjusting the RCVR GAIN knob will regulate both the received signal and sidetone volume.)

The TR-6 uses automatic transmit/receive switching. This means it will automatically transmit when the key is depressed and will remain in the transmit condition through keying. It will return to the receive condition when the key is released for a brief period. If this period is too long, decrease the VOX gain control to minimum.

If the relay fails to close when the function switch is placed in the CW position and the key, if used is closed, the VOX gain control should be advanced until positive relay action is obtained.

Manual transmit receive switching can be accomplished by connecting an external switch (e.g. foot switch) to the push to talk circuit of the MIC jack.

D. AM OPERATION

For AM operation, the FUNCTION switch should be in the AM position and the filter switch should be in the USB position (AM position if an AM filter has been installed). If a key is used, it should be left closed or unplugged.

Tune in the AM signals for most pleasing audio. With the USB filter this will not necessarily coincide with maximum S-meter reading.

The same procedure should be followed in setting the various gain controls for VOX operation on AM as for SSB, except that the XMTR GAIN should be adjusted for plate current peaks of from .2 to .25 amps when talking into the microphone in a normal voice. Care should be taken to stay within these limits since the transmitting AGC does not work on AM.

The TR-6 uses a controlled carrier screen modulator which holds the unmodulated carrier input power to a few watts but allows 300 watts P.E.P. input on voice peaks. This system is compatible with SSB linear amplifiers. Due to the low duty cycle of this type of AM, a linear can be run with the same P.E.P. input as it can on SSB.

E. GENERAL PRECAUTIONS FOR OPERATION NEAR BAND EDGE

If you intend to operate near the edge of a band, be sure that you check the dial calibration as described under tuning procedure. When working SSB be sure you are using the sideband that will be inside the band. On AM or CW, the transmitted carrier will be 1 KHz higher than the indicated dial frequency.

F. OPERATION WITH LINEAR AMPLIFIERS

The TR-6 transceiver is conservatively rated at 300 watts PEP input. It is doubtful if it would be worthwhile to use a linear with power rating of less than 1000 watts PEP input. A triode type grounded grid linear of 1000 to 2000 watt PEP rating will present a satisfactory load for the TR-6.

If your particular linear is of the grounded cathode type with high impedance input, it will be necessary to install a resistive pad between the TR-6 and the linear that will present the proper impedance to the TR-6. Such a pad must be made of non-inductive resistors and must have adequate power handling capacity to prevent it from being destroyed when the TR-6 is turned on. Antenna switching should be accomplished as shown in Figure 5. Many linears have these relays built in.

In order to properly operate the TR-6 with a linear, proceed as follows:

1. With the TR-6 connected to the linear, perform a tune-up as described in paragraph C of section VI.

2. Switch the FUNCTION switch to the desired mode of operation.
3. Set the XMTR GAIN control until the desired amount of input to the linear amplifier is obtained.

Note that when the TR-6 is loaded much below maximum RF output, the AGC does not function properly and flat topping in the TR-6 may result. Care should be taken to keep the XMTR GAIN below the point where this occurs. This can be accomplished by making sure that the average peak plate current does not exceed one third of the plate current obtained on tune-up (step 4).

If your linear amplifier has AGC output, connect it to the TR-6 as shown in figure 5. If the TR-6 is properly tuned, this should prevent flat topping on SSB regardless of the XMTR GAIN control setting. However, it will not prevent overdrive on AM since the AGC does not function in this mode.

G. RTTY OPERATION

The TR-6 is capable of RTTY communications in the AFSK as well as in the RFSK mode. AFSK communications can be achieved by switching the TR-6 function switch to AM and feeding the audio signal into the microphone jack of the TR-6. Switching the TR-6 function switch to the SSB mode under these same conditions will result in simulated RFSK emission.

If RTTY operation using true RFSK is contemplated, write for special instructions.

VIII. THEORY OF OPERATION

A. RECEIVER CIRCUITRY

A signal entering the TR-6 through the antenna jack (J-4) is applied to a tuned 6 meter circuit formed by L-10 and associated circuit and stray capacity.

L-10 also performs an impedance transformation from the 50 ohm line to the input of the receiving RF amplifier, Q-11.

After amplification in Q-11, Q-12, the signal goes through a 49.4 to 54.0 MHz bandpass formed by T-17, L-15, and their associated capacities.

The signal then is mixed in Q-13 with an appropriate crystal controlled frequency to a range of 13.9 to 14.5 MHz. The injection signal is obtained from a switchable crystal oscillator (Q-7), through a buffer (Q-9).

After passing through a 13.9 to 14.5 MHz bandpass formed by L-14, T-18, C-209, C-223, C-191, C-224, the signal is mixed in V-3 with a signal of a frequency variable between 4.9 and 5.5 MHz to obtain the fixed IF frequency of 9 MHz.

The variable frequency is obtained from the VFO formed by Q-1, Q-2, and associated circuitry.

The signal then passes through the IF crystal filter and is amplified in V-11 and V-12 and is coupled to the AVC amplifier and detector system.

V-13a serves as an AVC amplifier, the AVC voltage developed on the plate of that tube controls the bias and thereby the gain of Q-12, V-3, V-11, and V-12.

V-16 serves as the BFO and product detector. The audio signal is then amplified in V-17 to speaker level.

On AM the diode section of V-2 serves as an envelope detector, and the triode section serves as an audio amplifier. On CW the triode section is converted into an audio generator to generate the sidetone signal. The audio signal from V-2 then passes on to V-17 for final amplification.

B. TRANSMITTER CIRCUITRY

The IF carrier is generated in a crystal oscillator formed by V-16. After passing through the balanced modulator (D-11 through D-14), the signal is amplified in V-15 and then passed through the IF crystal filter.

The signal is then passed to V-7 where it is mixed with the VFO frequency to give the VIF 13.9 to 14.5 MHz.

After passing through the VIF bandpass formed by T-10, C-291, and C-292, the signal is fed to V-4 where it is mixed with a signal from the switchable crystal oscillator to give the desired output frequency. The signal is then amplified in V-6, V-8, V-9, and V-10 and is connected to the antenna jack (J-4) through a pi-network consisting of C-294, L-19, and C-293.

In the sideband mode, the audio signal from the microphone is amplified in V-18, and then mixed with the IF carrier in the balanced modulator, to give a double sideband, suppressed carrier signal. It is then processed as described above.

In the CW mode the modulator is unbalanced by means of a variable DC voltage (variable through R-100) to give an output on the carrier frequency. The keying is accomplished by keying the bias on V-7.

In the AM mode the balanced modulator is unbalanced with a fixed DC voltage. The modulation takes place as a controlled carrier screen modulation of the RF final amplifier tubes (V-8, V-9, V-10). The audio signal path is: From the microphone through the microphone amplifier (V-18) to the AM modulator (V-14) and from there to the final amplifier tube screens grids.

The transmitting AGC is generated in V-13b. The plate of this tube goes negative at the threshold of grid current in the final tubes (SSB mode only). This negative voltage reduces the gain of V-15, thus preventing any excessive amount of grid current in the final tubes which could cause flat topping.

Transistor Q-10 serves as a buffer for the transmitting VIF output.

C. TRANSCEIVING CIRCUITRY

Transmit-receive switching is accomplished by means of relay K-1. One set of DT contacts accomplishes the antenna switching from the transmitting to the receiving section, whereas the other set grounds the cathodes of those tubes used only for transmitting or receiving, respectively,

thus activating the respective sections of the transceiver.

Transistor Q-5 accomplishes the T/R switching of the receiver's front-end field effect transistors Q-11 and Q-13 by ground their sources.

The relay is activated by tube V-19, which is triggered by a signal from the microphone amplifier (V-18), a signal from the sidetone generator (CW only), or the closing of a PTT contact. The ANTI-VOX signal coming from tube V-17 is also fed to V-19.

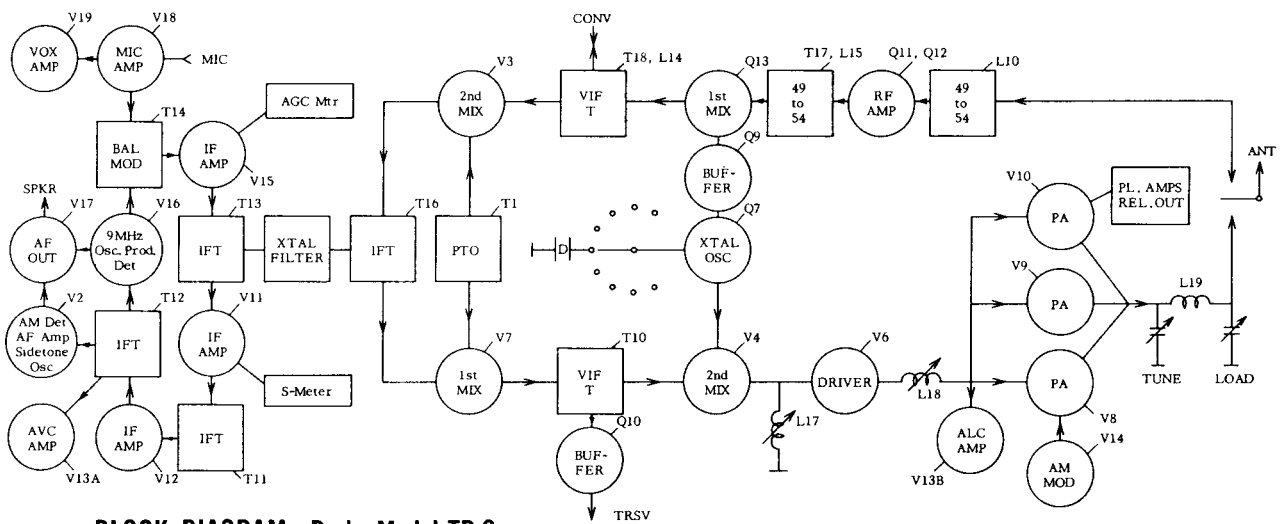

BLOCK DIAGRAM - Drake Model TR-6

Fig. 10 DC voltages during transmit/receive in the SSB mode, no signal received or transmitted, R-113 in CW position.

Pin # Device	1 (emitter, source)	2 (base, gate)	3 (collector, drain)	4	5	6	7	8	9
V-1	150	0		0	150		0		
V-2	0	3.5	12.6H	0	0	0	245		
V-3	- .6	150/.9	0	6.3H	240	155/25	0		
V-4	2.5	0	2.5	6.3H	0	0	240	160	0
V-5	0	30	12.6H	6.3H	150	150	30		
V-6	6.0/200	0	0	6.3H	0		250	200/250	0
V-7	0	0	0	6.3H	225/215	140/200	2.9/200		
V-8	250	-60	0/200	6.3H	12.6H	-60	250	0	
V-9	250	-60	0/200	6.3H	12.6H	-60	250	0	
V-10	250	-60	0/200	6.3H	12.6H	-60	250	0	
V-11	0	150/2.0	0	6.3H	210/225	170/150	0		
V-12	0	0	12.6H	0	210/225	180/120	150/1.3		
V-13	0	-65	-60	0	0	0	-65	-63	6.3H
V-14	250	13.0	13.0	12.6H	0	13.0	-1.0	0	45
V-15	0	0	0	12.6H	225/205	100/200	1.7/200		
V-16	-2.0	4.0	0	6.3H	130	150	0		
V-17	24/22	0	24/22	0	6.3H		220	200	24/22
V-18	75	- .5	0	0	12.6H	110	0	1.1	6.3H
V-19	190/250	- .5/-6.0	0	6.3H	0	100	0	1.2	0
Q-5	0	0/.7	18.0/.1						
Q-6	0	0	60						
Q-7	3.7	4.1	12						
Q-8	0	0	10						
Q-9	7.8/7.0	8.5/7.7	17.0/15.0						
Q-10	6.0/7.0	6.8/7.8	17.0/15.0						
Q-11	18.0/.6	0	10.0/7.0						
Q-12	10.0/7.0	6.0/5.0	18.0/15.0						
Q-13	18.0/4.0	0	18.0/15.0						
Q-14	0	0	-12.5						
Q-15	-13.0	-12.5	6.0/5.0						
J-2	250	0	0/200	0	150/0	0	12.6H	0	
J-11	0	0	150/0	0	12.6H	0	0	0	

Fig. 11 Resistance Chart

Function switch in the SSB position. Power supply disconnected, all controls CCW.

Pin # Device	1 (emitter, source)	2 (base, gate)	3 (collector, drain)	4	5	6	7	8	9
V-1	10K	0		0	10K		0		
V-2	3.3M	inf.	H	0	150K	150K	350K		
V-3	4.5M	1K	0	H	10K	2.2M	0		
V-4	330	0	330	H	0	0	10K	40K	
V-5	1M	inf.	H	H	350K	120K	inf.		
V-6	20K	68K	0	H	0		10K	20K	0
V-7	660K	0	0	H	10K	40K	20K		
V-8	10K	30K	20K	H	H	30K	20K	0	
V-9	10K	30K	20K	H	H	30K	20K	0	
V-10	10K	30K	20K	H	H	30K	20K	0	
V-11	2.5M	136	0	H	10K	13K	0		
V-12	2.5M	0	H	0	10K	9K	68		
V-13	1M	15K	32K	0	0	2.5M	50K	45K	H
V-14	10K	2.2M	2.2M	H	0	2.2M	22M	0	6K
V-15	2M	0	0	H	10K	13K	20K		
V-16	2.2M	1K	0	H	250K	10K	22K		
V-17	4K	4K	4K	0	H	10K	10K		4K
V-18	350K	6.8M	0	0	H	250K	0	3.3K	H
V-19	10K	5M	0	H	0	110K	22K	820	1M
J-2	10K	250K	20K	0	0	inf.	H	0	
J-11	0	0	0	0	H	0	0	0	0

IX. SERVICE DATA

We will check and factory align your TR-6 for a nominal fee of \$10.00 plus transportation charges if the set has not been tampered with. If repairs are necessary, an additional charge will be made. Units that have been tampered with or misaligned will be repaired on a time and material basis only.

A. REMOVING TOP COVER

WARNING: Extreme caution should be taken when the top and bottom covers of the TR-6 are removed. High voltage is present at several points which could cause a lethal electrical shock.

1. Remove the three top screws on each side of the TR-6.
2. Remove cover by first pulling up on the rear and then on the front of the cabinet.

B. REMOVING BOTTOM COVER

1. Remove the six bottom screws from the sides of the TR-6.
2. Lift TR-6 chassis out of bottom cover.

C. TUBE REPLACEMENT

In general, most trouble in radio equipment of good design is due to tube failure. The best method of finding defective tubes is by direct substitution. It is best not to rely too heavily on tube checkers.

The TR-6 has been designed so that, with the exception of V-6, V-8, V-9, and V-10, tubes can be replaced without need for realignment. These tubes are to be replaced with the same brand as originally supplied. Realignment of L-17, C-243, and C-276 is necessary. See Section X.

To replace the 6JB6 tubes it is necessary to remove the top of the final amplifier cage. To do this, remove the sheet metal screws holding the PA cover to the cage. A disc-handle is provided on the cover to facilitate removal. To replace the PA cover, simply reverse the process. Be sure the parasitic suppressors do not short to the cage.

D. TROUBLESHOOTING

Careful consideration has been given in the design of the TR-6 to keep maintenance problems to a minimum. However, it is quite possible that some problem will arise which cannot be cured by tube substitution.

If this occurs, we suggest that you either return your unit to your dealer, or write direct to our Customer Service Department describing your problem in detail. Include full information concerning external connections, control settings, tubes substituted, etc. Always disclose your serial number when requesting service information. Do not return equipment to the factory without prior authorization.

In case of malfunction, first check power supply fuse, filament fuse in TR-6, and between pins 1 and 2 of the TR-6 power jack (J-3) for continuity. The voltage and resistance charts (figs. 10, 11) should be valuable in isolating minor problems.

No attempt should be made to service the TR-6 unless one is thoroughly familiar with electronic circuitry and servicing technique.

CARE SHOULD BE TAKEN NOT TO DISTURB THE LEAD DRESS IN THE TR-6 SINCE SEVERAL CIRCUITS ARE QUITE CRITICAL IN THIS REGARD.

Fig. 12 AC voltages (values given are approximate)

A. During SSB transmitting

Pin #	Device	Voltage (volts RMS)	Frequency (MHz)	Remarks
2	V-18	.003	audio	ALC threshold, R-175 in CW position
8	V-18	.04	audio	ALC threshold
1	V-15	.03	9	ALC threshold
1	V-15	.25	9	Function switch on "CW", R-100 in CW position
1	J-11	.05	9	ALC threshold
1	V-7	.12	9	ALC threshold
1	V-7	.55 ± .15	4.9-5.5	
2	V-4	.25	13.9-14.5	ALC active
2	V-4	1.0 ± .3	35.5-39.5	
7	V-4	3.5	49.4-54.0	ALC active
2	V-8	40	49.4-54.0	ALC active
	J-4	100	49.4-54.0	ALC active

B. During SSB receiving

Pin #	Device	Voltage (volts RMS)	Frequency (MHz)	Remarks
	J-4	1×10^{-5} typ.	49.4-54.0	Calibrator signal
	J-4	1×10^{-7} typ.	49.4-54.0	AVC threshold
	J-4	1×10^{-5} typ.	49.4-54.0	S-meter on S-9
gate	Q-13	1×10^{-5}	49.4-54.0	AVC threshold
gate	Q-13	6×10^{-6}	13.9-14.5	AVC threshold
source	Q-13	$1.4 \pm .4$	35.5-39.5	
1	V-3	1×10^{-4}	13.9-14.5	AVC threshold
1	V-3	5×10^{-5}	9	AVC threshold
2	V-3	.55 ± .15	4.9-5.5	
1	J-11	3×10^{-5}	9	AVC threshold
1	V-11	.001	9	AVC threshold
1	V-12	.03	9	AVC threshold
7	V-13	.65	9	S-meter up-scale
5	V-16	3.5	audio	S-meter up-scale

X. ALIGNMENT INSTRUCTIONS

A. Alignment of the TR-6 will require the following equipment:

1. An alignment tool (General Cement #8273 or #8276) and a screw-driver (3/16").
2. Two alignment loads, each consisting of a .001 uf 500 V capacitor in series with a 1 K ohm 1/2 watt resistor. Alligator clips on each end of the series combination will be found convenient.
3. A signal generator covering 14 to 58 MHz with an adjustable output attenuator.
4. A sensitive RF voltmeter or a 6 meter receiver.
5. A 37.5 MHz crystal and a 39.0 MHz crystal inserted into their proper sockets (see figure 15).
6. An inductance probe consisting of pieces of copper and ferrite respectively, approximately 1/2" by 1/8" DIA attached to each end of an insulating handle.
7. A receiver capable of receiving WWV.
8. A 50 ohm non-reactive load capable of handling the TR-6 RF output power (200 W).

NOTE: If the S-meter does not read upscale in cases where the instructions call for adjustment by S-meter readings, use an audio voltmeter at the speaker terminals instead. The bottom cover of the TR-6 should be in place during alignment, whenever this is possible.

B. Before alignment is attempted the cathode lead of the final amplifier tubes should be disconnected where it passed through the partition under the chassis (RFC-2).

C. BE SURE POWER IS DISCONNECTED BEFORE THIS IS ATTEMPTED, OR SERIOUS ELECTRICAL SHOCK WILL RESULT.

D. Let the TR-6 warm up preferably for as much as 30 minutes before the alignment procedure is started.

E. Receiver IF alignment

With the antenna disconnected, adjust T-11 and T-12 tops and bottoms for maximum audio noise output.

F. Filter matching transformers

1. Tune in a crystal calibrator signal and tune the VFO for maximum S-meter reading (on USB, SSB mode).
2. Tune the VFO for a higher pitched signal until the S-meter drops 3 S-units (15 dB).
3. Adjust T-13 and T-16 for maximum S-meter reading.

G. 9 MHz Oscillator Alignment

1. Tune in a calibrator signal for maximum S-meter reading (on USB, SSB).
2. Tune the VFO for a lower pitched signal until the S-meter drops 4 S-units (20 dB).
3. Adjust C-130 for zero beat.

NOTE: If an LSB filter is installed, the S-meter should read the same on USB and LSB when the signal is tuned for zero beat. Adjust C-130 until this is the case.

H. Receiver VIF alignment

1. Tune in a calibrator signal at 50.2 MHz.
2. Place an alignment load across C-224.
3. Adjust C-223 for maximum S-meter reading.
4. Move the alignment load to C-223.
5. Adjust C-224 for maximum S-meter reading.

I. Receiving Traps

1. Tune the signal generator to 57.75 MHz and connect its output to the antenna jack of the TR-6.
2. Increase the output voltage of the generator until a spurious signal can be received on the TR-6 at 50.25 MHz.
3. Adjust R-207 and C-120 for minimum S-meter reading.

NOTE: The following alignment has been carefully made in the factory and should not be realigned unless there is strong evidence of misalignment.

4. Move the signal generator to 55.25 MHz to receive a spurious signal on the TR-6 at 50.25 MHz.
5. Using the inductance probe determine if L-23 is tuned for minimum S-meter reading. The inductance of L-23 can be changed slightly by squeezing.

J. Receiver Front end alignment

1. Connect an alignment load each from the drain of Q-12 and the gate of Q-13 to ground, and a carbon resistor across J-4 (50 ohms).
2. Tune in a crystal calibrator signal at 51.7 MHz.
3. Tune T-17 top for maximum S-meter reading.

NOTE: Of the two possible peaks, select the one with the slug screw further inside the can.

4. Tune L-10 for maximum S-meter reading.
5. Remove the two alignment loads, and connect one alignment load in parallel with C-187.
6. Tune T-17 bottom for maximum S-meter reading

NOTE: Of the two possible peaks, select the one with the slug screw further out of the can.

7. Peak L-15 for maximum S-meter reading.
8. Connect the output of a signal generator in parallel with the alignment load, and tune the signal generator to 14.2 MHz.
9. Switch off the calibrator and adjust C-149 for minimum S-meter reading.
10. Disconnect the hot side of the signal generator output, switch on the calibrator and adjust L-15 for maximum S-meter reading.
11. Repeat steps 8, 9, and 10 of this paragraph until both conditions appear to be met simultaneously.

NOTE: In some units, 2 peaks are possible in L-10, L-15. Select the peak that makes the alignment screw stick out further above the chassis.

K. Calibrator alignment

1. Connect the antenna jacks of a WWV receiver and the TR-6 to each other and an antenna.
2. Receiving WWV adjust C-245 until the calibrator signal from the TR-6 zero beats with the WWV carrier.

L. VFO Adjustment

The permeability tuned VFO was carefully adjusted at the factory and should require no further alignment. If it does not appear to track from one end of its range to the other, it should be returned to our plant for realignment. Maximum calibration error is 1 KC when calibrated to the nearest 100 KC point.

If you notice the same error from one end of the band to the other, and you cannot correct it with the movable dial index, the main dial may be slipped on its shaft enough to bring the corrector back into range.

M. Driver and Mixer Tuned Circuits

1. It is assumed that paragraphs B,C, and D of this section have been read and followed.
2. Temporarily remove C-277.
3. Connect a sensitive RF voltmeter or a 6 meter receiver to the antenna jack of the TR-6 to monitor the TR-6 output.
4. Tune the TR-6 to 50.2 MHz.
5. Switch the function switch to "CW" and advance the XMTR GAIN control just enough to read the output signal of the TR-6.
6. With the C-208 control (driver tune) on "5", adjust L-17,L-18, for maximum output from the TR-6.

NOTE: The following alignment has been carefully made in the factory and should not normally require realignment.

7. For alignment of the increment coils mounted on S1CF and S1DR, a complete set of range crystals is required.
8. Leaving the PTO dial on .200 and C-208 in its center position, start in the 53.5 position of the range switch by peaking L-17,L-18. Moving the range switch successively to the lower ranges, the associated increment coils are adjusted by bending them towards the wafer for less inductance and vice versa. The inductance probe described under 6 of paragraph A of this section applied to L-17, L-18 in every instance, should prove helpful. The tracking of L-18 is less critical due to the provisions of C-208.

CAUTION: The increment coils on S1CF are connected to 250 V. Use an insulated bending tool.

N. Transmitter VIF Alignment

1. It is assumed that steps 1 through 5 of paragraph M have been performed.
2. Connect an alignment load from pin 2, V-4 to ground.
3. Peak T-10 top for maximum output from the TR-6.
4. Place the alignment load from pin 5, V-7 to ground, and peak T10 bottom.

CAUTION: 250 V present at pin 5, V-7.

O. Transmitter IF and Carrier Balance Alignment

1. It is assumed that steps 1 through 5 of paragraph M have been performed.
2. Adjust T-14 for maximum output from the TR-6.
3. Turn the XMTR GAIN control counter-clockwise and alternately adjust C-127 and R-185 for minimum output from the TR-6.

P. Range Oscillator Alignment

1. It is assumed that steps 1 through 5 of paragraph M have been performed.
2. Switch the TR-6 to a frequency in the 53.0 MHz range.
3. Adjust L-22 for maximum output from the TR-6.

Q. Transmitter IF Neutralization

1. Feed a signal consisting of at least two audio tones into the microphone jack of the TR-6. (In lieu of anything else, plug in your microphone and talk into it.)
2. Disable the VOX by turning R-198 counter-clockwise; do not activate push to talk.
3. Adjust C-168 until minimum audio is heard in the speaker or headphones.

NOTE: If this adjustment requires more than one turn at C-168, the alignment described in paragraph P should be repeated.

R. RF Power Amplifier Neutralization

1. Disconnect power and reconnect RFC-2, C-277.
2. Reconnect power and tune up as described in Section VI, on 50.2 MHz.
3. Set C-208 (DRIVER TUNE control) to center range "5".
4. Reduce drive by R-100 (XMTR GAIN control), and readjust L-17, L-18 for max. RF output.
5. Adjust C-276 so that maximum output and plate current dip occur simultaneously. Care should be taken to insure that drive is kept below saturation level during this adjustment.
6. Readjust L-17, L-18 to make sure they are still peaked.

NOTE: In case of severe misalignment, step R may be preceded by minimizing RF-feed-through in the respective amplifier stages with the DC cathode leads broken (R-236 disconnected from C-273 or RFC-2 disconnected from C-274 respectively).

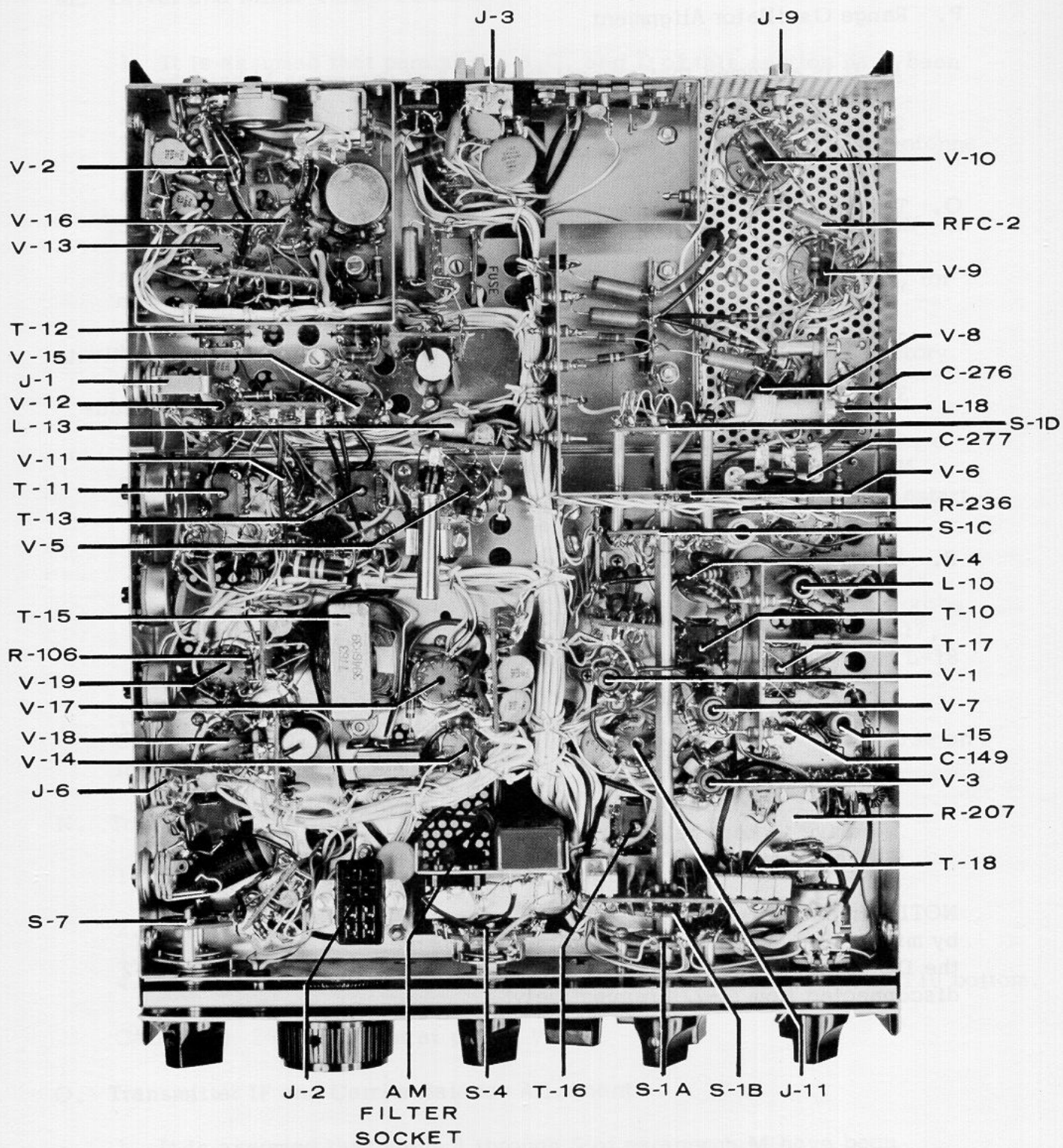

FIG.13-BOTTOM VIEW

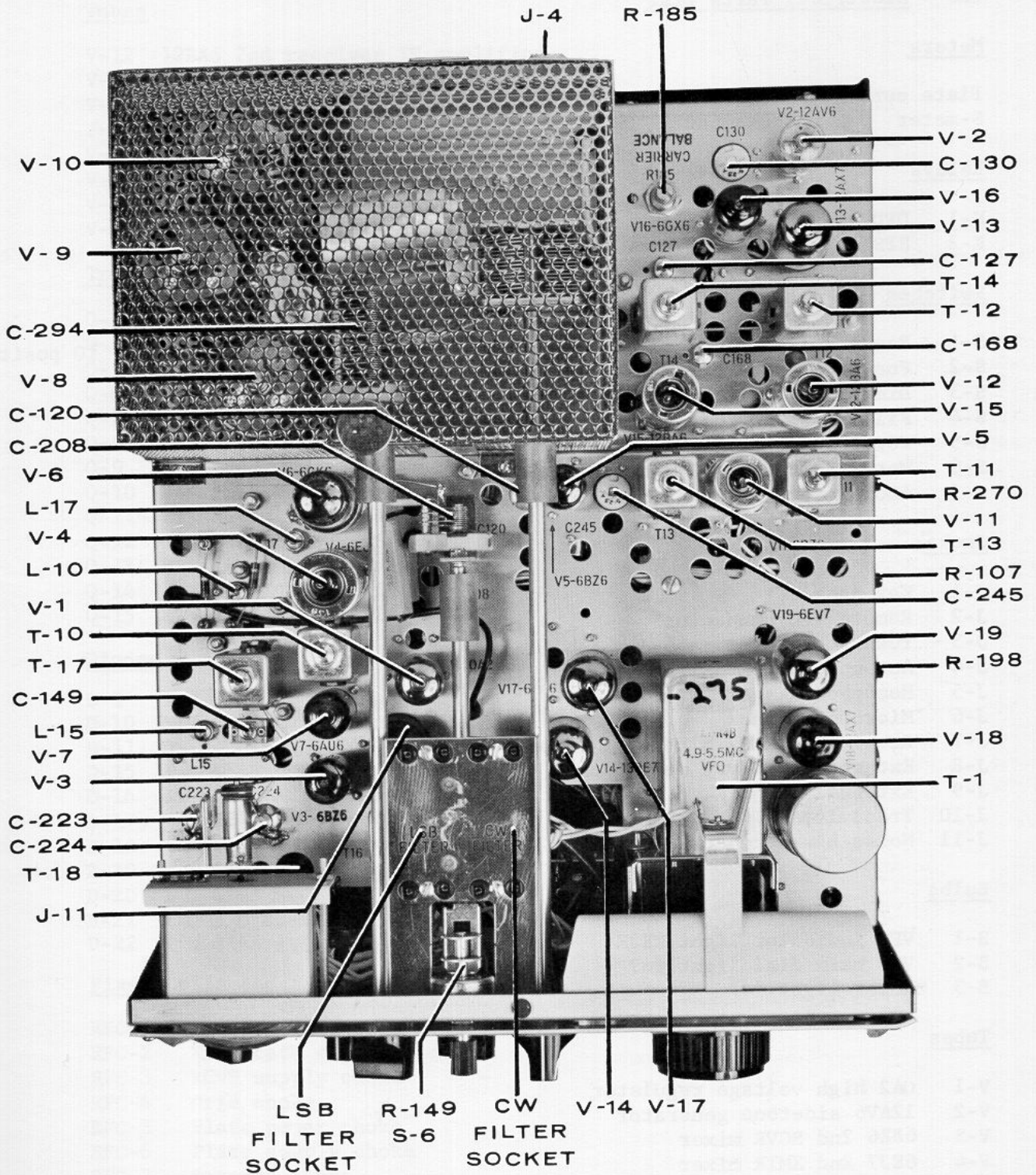

FIG.14 —TOP VIEW

XI - TR6 - Electrical Parts List

Meters

Plate current meter 0-5 mA movement
S-meter 0-5 mA movement

Relays

K-1 DPDT & SPST T/R relay
K-2 SPST carrier oscillator relay

Switches

S-1 Range switch. 3 single function wafers, 1 double function wafer. 10 positions
S-2 Function switch. 2 double function wafers. 4 positions
S-3 Dim-bright switch. SPST slide switch
S-4 Filter switch. 1 double function wafer. 4 positions
S-5 Power switch. SPST ganged to R-176
S-6 Meter switch. SPST ganged to R-149
S-7 AGC switch. 1 single function wafer. 4 positions

Jacks

J-1 Key jack
J-2 Remote VFO connector
J-3 Power connector
J-4 Antenna jack
J-5 Headphones jack
J-6 Microphone jack
J-7 Receiver 14 MHz VIF input/output jack
J-8 External receiver mute jack
J-9 External AM jack
J-10 Transmitter 14 MHz VIF output jack
J-11 Noise blanker jack

Bulbs

B-1 VFO indicator light NE2E
B-2 VFO main dial light #47
B-3 Meter light #47

Tubes

V-1 6AQ5 high voltage regulator
V-2 12AV6 sidetone generator
V-3 6BZ6 2nd RCVR mixer
V-4 6EJ7 2nd XMTR mixer
V-5 6BZ6 (RCA) calibration generator
V-6 6GK6 (Sylvania) transmitting driver
V-7 6AU6 1st transmitter mixer
V-8, V-9, V-10 6JB6 (Sylvania, matched) XMTR output amplifier
V-11 6BZ6 1st receiver IF amplifier

Tubes

V-12 12BA6 2nd receiver IF amplifier
V-13 12AX7 (Sylvania) AGC generator
V-14 13DE7 AM-modulator
V-15 12BA6 XMTR IF amplifier
V-16 6GX6 product detector
V-17 6GK6 RCVR output amplifier
V-18 12AX7 (RCA) microphone amplifier
V-19 6EV7 VOX amplifier

Transistors

Q-1 MPF 102 variable frequency oscillator
Q-2 2 N 3858 VFO buffer
Q-5 2 N 3394 T/R switch
Q-6 2 N 3877 light switch
Q-7 2 N 3394 range oscillator
Q-8 2 N 3394 VFO switch
Q-9 2 N 3663 range buffer
Q-10 2 N 3663 VIF buffer
Q-11 TIS 88 1st RCVR RF amplifier
Q-12 TIS 88 2nd RCVR RF amplifier
Q-13 MPF 102 1st RCVR mixer
Q-14 2N5365 AVC amplifier
Q-15 2 N 3394 AVC amplifier

Diodes

D-1 1 N 714 low voltage regulator
D-10 B5G5 2nd ANTIVOX rectifier
D-11, D-12, D-13, D-14 1 N 541 balance modulator
D-15 1 N 4148 VOX rectifier
D-16 B5G5 1st ANTIVOX rectifier
D-17 1 N 4148 pulse rectifier
D-18 1 N 4148 T/R switch
D-19 1 N 270 RF-rectifier
D-20 1 N 4148 AVC switch
D-21 1 N 270 RF-rectifier
D-22 1 N 4148 AVC switch

Fixed Coils and RF Chokes

RFC-1 Driver plate choke
RFC-2 XMTR cath supply choke
RFC-3 RCVR supply choke
RFC-4 Grid choke
RFC-5 Plate power choke
RFC-6 Plate supply choke
RFC-7 Antenna choke
RFC-8 Driver suppressor
RFC-9 RFC-10, RFC-11 XMTR suppressor
RFC-12 Screen choke
RFC-13 250V supply choke
RFC-14 Cathode tuning choke
RFC-15 Isolation choke
RFC-16 Screen Choke

Tuned Coils

L-1 VFO tank coil
L-2 VFO output coil
L-10 Antenna coil
L-11 Trap coil
L-12 thru L-16 RCVR 50 MHz bandpass coils
L-17 Mixer coil
L-18 Driver coil
L-19 Final coil
L-20 1st 14 MHz receiver bandpass coil
L-21 2nd 14 MHz receiver bandpass coil
L-22 Crystal oscillator coil
L-23 Calibrator peaking coil

Coil Assemblies

T-1 VFO
T-10 14 MHz bandpass (double tuned)
T-11 1st RCVR IF transformer (double tuned)
T-12 2nd RCVR IF transformer (double tuned)
T-13 2nd Filter match transformer (single tuned, 2 windings)
T-14 XMTR IF transformer (single tuned, 2 windings)
T-15 Output transformer (untuned)
T-16 1st Filter match transformer (single tuned, 2 windings)

Crystals and Crystal Filters

X-1 100 KHz
X-2 35.5 MHz (not supplied)
X-3 36.0 MHz
X-4 36.5 MHz
X-5 37.0 MHz (not supplied)
X-6 37.5 MHz (not supplied)
X-7 38.0 MHz (not supplied)
X-8 38.5 MHz (not supplied)
X-9 39.0 MHz (not supplied)
X-10 39.5 MHz (not supplied)
X-11 9.0 MHz

USB Filter
LSB Filter (not supplied)
AM Filter (not supplied)
CW Filter (not supplied)

<u>Capacitors</u>	<u>Value</u>	<u>Location on Schematic</u>	<u>Physical Location</u>
1	Selected	Q-1	VFO
2	.01	Q-2	VFO
3	10	Q-1	VFO
4	390	Q-2	VFO
5	.01	Q-1	VFO

<u>Capacitors</u>	<u>Value</u>	<u>Location on Schematic</u>	<u>Physical Location</u>
6	Selected	Q-1	VFO
7	.01	Q-1	VFO
8	10	Q-1	VFO
9	47	Q-2	VFO
10	90	Q-2	VFO
11	.005	Q-2	VFO
12	.01	Q-1	VFO
100	.01 Z5U 500V	V-11	IF board
101	.005 Z5U 500V	V-11	V-11 socket
102	500 mica DM15	V-11	V-11 socket
103	35 in can	V-11	T-11
104	35 in can	V-12	T-11
105	.001 1KV Z5U	V-12	V-12 socket
106	.005 500V Z5U	V-12	V-12 socket
107	.005 500V Z5U	V-12	V-12 socket
108	35 in can	V-12	T-12
109	100 mica DM15	V-16	DET board
110	.005 500V Z5U	V-13a	V-13 socket
111	68 N 750	V-16	V-13/V-16 sockets
112	.005 500V Z5U	V-13a	DET board
113	.02 100V	V-12	AVC board
114	.005 500V Z5U	V-13a	DET board
115	.47 100V	V-13a	S-7
116	.47 100V	V-13b	ALC board
117	1.5 gimmick	V-15	T-13
118	.001 1KV Z5U	V-18a	J-6
119	.001 1KV Z5U	V-16	V-16 socket
120	1-6 var	Q-11	Top chassis near V-5
121	.005 Z5U 500V	V-19b	VOX board
122	.005 Z5U 500V	V-2	V-2 socket
123	1000 DM20 mica	V-15	V-11 socket
124	.01 Z5U 500V	V-15	V-15 socket
125	.005 Z5U 500V	V-15	V-15 socket
126	.001 Z5U 1KV	V-15	V-15 socket
127	1-8 var	V-15	Top chassis BFO compt.
128	.005 Z5U 500V	V-15	T-14
129	470 1KV Z5U	V-16	V-16 socket
130	2-25 var	V-16	Top chassis BFO compt.
131	470 1KV Z5U	V-16	DET board
132	150 mica DM15	V-16	V-16 socket
133	.01 500V Z5U	V-16	V-16 socket
134	.0015 Z5U 1KV	V-16	DET board
135	10 μ f elyt 25V	V-17	AUD board
136	.01 500V Z5U	V-17	AUD board
137	470 Z5U 1KV	V-18a	MIC board
138	.001 Z5U 1KV	V-18a	AUD board
139	.47 100V	V-18b	AUD board
140	.005 500V Z5U	V-19a	V-18 socket

<u>Capacitors</u>	<u>Value</u>	<u>Location on Schematic</u>	<u>Physical Location</u>
141	.01 500V Z5U	V-19a	VOX board
142	.01 500V Z5U	V-19	AUD board
143	.1 200V	V-19b	VOX board
144	.02 100V	V-19	AVC board
145	10 μ f elyt 25V	V-19a	can
146	.01 Z5U 500V	V-12	IF board
147	.005 Z5U 500V	V-16 htr.	V-16 socket
148	.001 feedthrough	V-10 htr.	Final shield
149	8-60 var	Q-13	Conv. compt. top chass.
150	3.3 gimmick	Q-11	Conv. compt.
151	.001 feedthrough	V-10	Final shield
152	.0024 1KV Z5U	V-12	T-11
153	.001 1KV Z5U	V-8	J-9
154	.01 500V Z5U	V-1	J-3
155	.001 Z5U 1400V	V-10	J-3
156	.001 Z5U 1400V	V-10	J-3
157	.001 Z5U 1KV	V-10	J-3
158	.01 Z5U 500V	V-10	J-3
159	.001 1KV Z5U	V-10	J-3
160	.001 1KV Z5U	Q-1	J-2
161	3.3 gimmick	V-10	MTR board
162	100 mica DM15	V-10	MTR board
163	.005 Z5U 500V	V-10	MTR board
164	.001 Z5U 1400V	Q-1	J-2
165	220 in can	V-15	T-14
166	.001 Z5U 1KV	Q-10	BUF board
167	.005 500V Z5U	V-13b	V-13 socket
168	8 var	V-15	Chassis top near V-15
169	.001 1KV Z5U	V-18a	J-6
170	.01 25V	Q-10	BUF board
171	.005 Z5U 500V	V-11 htr.	V-11 socket
172	Selected	V-15	V-16 socket
173	.005 Z5U 500V	V-13 htr.	V-12 socket
174	.005 Z5U 500V	V-6	V-6 socket
175	.001 Z5U 1KV	V-7	V-7 socket
176	68 N 750 disc	V-18a	V-18 socket
177	.005 500V Z5U	V-7	V-7 socket
178	.005 500V Z5U	V-7	V-4 socket
179	.01 500V Z5U	V-3	OSC board
180	500 JL	V-2	Sidetone board
181	500 JL	V-2	Sidetone board
182	500 JL	V-2	Sidetone board
183	500 JL	V-2	Sidetone board
184	220 Z5U 1KV	V-2	Sidetone board
185	68 N 750	V-2	V-2/V-13 sockets
186	feedthrough	Q-13	Conv. shield
187	3.3 gimmick	Q-11	Conv. compt.
188	.47 pf gimmick	Q-13	Conv. compt.
189	220 Z5U 1KV	V-14	V-14 socket
190	.001 Z5U 1KV	V-3	MIX board

<u>Capacitors</u>	<u>Value</u>	<u>Location on Schematic</u>	<u>Physical Location</u>
191	1.0 gimmick	Q-13	MIX board
192	1-7 var	Q-11	Conv. compt. top chassis
193	5.0 NPO	Q-7	OSC board
194	68 N 750	V-18b	V-18 socket
195	.001 Z5U 1KV	Q-2	Light board
196	.001 Z5U 1KV	V-10	MTR board
197	1.0 gimmick	V-11	V-11 socket
198	.001 Z5U 1KV	V-2	V-2 socket
199	.005 Z5U 500V	V-16	V-16 socket
200	.001 Z5U 1KV	V-10	J-3
201	10 μ f elyt 250V	V-17	Can
202	.01 Z5U 500V	V-11	IF board
203	1.5 gimmick	V-15	T-13
204	.001 1KV Z5U	V-5	CAL board
205	.02 100V	V-19	Near AVC board
206	.001 Z5U 1KV	Q-13	MIX board
207	500 mica DML5	V-8	Final compt.
208	8 pf var	V-6	Front control
209	6.8 tubular N 1500	Q-13	MIX board
210	.01 25V	Q-13	MIX board
211	.001 Z5U 1KV	V-7	Near V-6
212	.001 Z5U 1KV	V-3	J-11
213	.001 Z5U 1KV	V-19b	V-10 socket
214	.001 feedthrough	Q-2	Conv. shield
215	.001 Z5U 1KV	Q-8	J-2
216	.01 25V	Q-13	MIX board
217	.33 gimmick	V-5	CAL board
218	.01 25V	Q-9	MIX board
219	39 NPO	V-11	V-11 socket
220	6.8 NPO	V-5	CAL board
221	470 Z5U 1KV	Q-11	Conv. compt.
222	.01 Z5U 500V	V-10	ALC board
223	3-10 N 470 var	Q-13	Top chassis conv. compt.
224	3-10 N 470 var	V-3	Top chassis conv. compt.
225	.001 feedthrough	Q-11	Conv. compt.
226	10 NPO	V-3	V-3/V-7 sockets
227	27 NPO	V-3	V-3 turret
228	.001 Z5U 1KV	V-3	V-3 turret
229	.005 Z5U 500V	V-3	V-3 socket
230	.005 Z5U 500V	V-4	V-4 socket
231	.02 100V	V-7	V-7 turret
232	.005 Z5U 500V	V-4	V-4 socket
233	.02 100V	Q-5	AUD board
234	.005 Z5U 1KV	V-3	V-3 socket
235	.001 Z5U 1KV	Q-9	MIX board
236	.001 Z5U 1KV	Q-9	MIX board
237	.01 25V	Q-11	MIX board
238	.01 25V	Q-5	MIX board
239	20 μ f elyt 250V	V-1	Can
240	.02 100V	V-2	BFO compt.

<u>Capacitors</u>	<u>Value</u>	<u>Location on Schematic</u>	<u>Physical Location</u>
241	100 mica DM15	V-6	V-4 socket
242	.005 500V Z5U	V-6 htr.	V-6 socket
245	5-25 NPO	V-5	Top chassis near V-5
246	.001 Z5U 1KV	V-5	CAL board
247	100 mica DM15	V-5	CAL board
248	.001 feedthrough	V-6	Final shield
250	.001 Z5U 1KV	V-6	Final compt. V-6 socket
251	.005 Z5U 500V	V-6	V-6 socket
252	.001 Z5U 1KV	V-10	Final compt.
253	.001 Z5U 1KV	V-9	Final compt.
254	.001 Z5U 1KV	V-9	Final compt.
255	.001 Z5U 1KV	V-8	Final compt.
256	.001 Z5U 1KV	V-8	Final compt.
257	.001 Z5U 1KV	V-10	Final compt.
258	.01 25V	V-5 htr.	V-5 socket
259	25 NPO	V-6	Final compt.
260	.001 feedthrough	V-6	Final shield
261	500 mica DM15	V-6	Final compt.
262	.001 1KV Z5U	V-10	J-8
263	60 μ f elyt 250V	V-1	Can
264	390 Y5E 1KV	V-8	Final compt.
265	.01 25V	Q-5	AUD board
266	5 NPO	Q-10	BUF board
267	.01 Z5U 500V	V-19b	Sidetone board
268	390 disc Y5E 1KV	V-9	Final compt.
269	.005 Z5U 500V	V-4	V-4 socket
270	.05 100V	V-3	MIX board
271	.001 1KV Z5U	V-19b	VOX board
272	390 Y5E 1KV	V-10	Final compt.
273	.001 1KV Z5U	V-6	Near V-6 socket
274	.001 feedthrough	V-10	Final shield
275	.001 feedthrough	V-8	Final shield
276	1-6 var	V-8	Final compt.
277	10 NPO	V-6	Final compt.
278	.001 2 KV	V-10	Final
279	1.5 2KV	V-8	Final
280	.001 1KV Z5U	V-8	Final compt.
281	.001 Z5U 1KV	V-9	Final compt.
282	.001 Z5U 1KV	V-10	Final compt.
283	.001 Z5U 1400V	V-10	Final
284	68 N 750	V-16	V-16 socket
285	.005 1400V Z5U	V-10	J-3
286	.001 feedthrough	V-13b	Final shield
287	.001 feedthrough	V-13b	Final shield

<u>Capacitors</u>	<u>Value</u>	<u>Location on Schematic</u>	<u>Physical Location</u>
288	.005 500V Z5U	Q-7	OSC board
289	.005 500V Z5U	Q-7	OSC board
290	6.8 NPO	Q-7	OSC board
291	39 NPO	V-7	T-10
292	33 NPO	V-7	T-10
293	360 var	V-10	Final
294	29 var	V-10	Final
295	20 NPO	Q-12	Conv. compt.
296	.01 25V	Q-12	MIX board
297	8.0 NPO	Q-7	OSC board
298	.33 gimmick	Q-11	Conv. compt.
299	1.0 gimmick	Q-11	Conv. compt.
300	.001	Q-12	Conv. compt.
301	.1	V-13a	AVC board
302	250 μ f elyt 50V	V-17	AUD board
303	.02 100V	V-3	J-11
304	.02 100V	V-18	V-18 socket
305	.001	V-3	MIX board

Resistors

.1	560 1/4W	Q-1	VFO
2	100 1/4W	Q-1	VFO
3	560 1/4W	Q-2	VFO
4	1M 1/4W	Q-1	VFO
5	330 1/4W	Q-1	VFO
6	100 1/4W 10%	Q-2	VFO
7	22K 1/4W 10%	Q-2	VFO
8	6.8K 1/4W 10%	Q-2	VFO
100	500K var	V-8	Front control
101	22K	V-19a	V-19 socket
102	100K	V-19a	VOX board
103	820	V-19a	V-19 socket
104	100K	V-19	VOX board
105	6.8M	V-19	VOX board
106	3.3M	V-19	VOX board
107	100K var	V-19b	Side control
108	3.3M	V-19b	VOX board
109	3.3K	V-18b	MIC board
110	2K 5W 10%	V-1	Top chassis
111	3.3K	V-1	VOX-MIC boards
112	1.5K 7W 10%	V-1	Top chassis
113	10K var	V-13a	Front control
114	1M	V-19	V-19 socket
115	1M	V-14	V-14 socket
116	68 1W 10%	V-10	S-3
117	330K	V-5	CAL board
118	1.5K	V-13b	DET board/V-13
119	68K	V-6	V-6 socket
120	100	V-17	V-17 socket
121	330	Q-13	MIX board

<u>Resistors</u>	<u>Value</u>	<u>Location on Schematic</u>	<u>Physical Location</u>
122	10	Q-7	OSC board
123	1M	V-2	V-2 socket
124	500K var	V-2	Rear control
125	330K	V-2	V-2 socket
126	330K	V-2	SIDET board
127	330K	V-2	SIDET board
128	330K	V-2	SIDET board
129	150K	V-2	V-2 socket
130	3.3M	V-2	SIDET board
131	1.5K	V-2	V-2/SIDET board
132	1K	V-3	OSC board
133	470	Q-9	MIX board
134	33	Q-9	MIX board
135	68K	V-19b	AVC board
136	1M	V-15	AIC board
137	6.8K	V-15	T-14
138	470 ½W 5%	V-15	BFO compartment
139	150	V-15	BFO compartment
140	12K 3W 10%	Q-1	V-1 turret
141	2.2M	V-16	BFO compartment
142	1M	V-19b	VOX board
143	680K	V-19	VOX board
144	68	V-12	IF board
145	68	V-12	IF board
146	1M	Q-13	Conv. compartment
147	150K	V-2	V-2 socket
148	270	V-17	Near IF board
149	10K var	V-10	Front control
150	330K	Q-8	Light board
151	330	Q-13	Conv. shield
152	10K	Q-7	OSC board
153	10K	Q-7	OSC board
154	330	Q-7	OSC board
155	1K	Q-7	OSC board
156	10K	Q-9	MIX board
157	10K	Q-9	MIX board
158	1.5K	V-16	DET board
159	150 2W 10%	V-8	Final cage
160	150 2W 10%	V-9	Final cage
161	150 2W 10%	V-10	Final cage
162	1M	V-10	Final cage
163	100	V-17	VOX-MIX boards
164	68K	Q-6	Light board
165	1M	Q-6	Light board
166	Filament Fuse	V-10	Near MTR board
167	12K 3W 10%	V-1	V-1 turret
168	100	Q-7	OSC board
169	1M	V-3	MIX board
170	560	Q-10	BUF board
171	10K	Q-10	BUF board
172	10K	Q-10	BUF board

<u>Resistors</u>	<u>Value</u>	<u>Location on Schematic</u>	<u>Physical Location</u>
173	10	Q-10	BUF board
174	100	Q-10	BUF board
175	500K var	V-18	Front control
176	500K log var	V-16	Front control
177	10	Q-9	MIX board
178	330	Q-9	MIX board
179	330	Q-10	BUF board
180	10	Q-10	BUF board
181	100K	Q-14	AMP board
182	10	Q-7	OSC board
183	180	V-13a	DET board
184	1K	Q-2	Light board
185	200 var	V-15	BFO compt. - top chassis
186	2.2M	V-16	BFO compt.
187	1K	V-16	BFO compt.
188	1.5K	V-16	DET board
189	2.2K	V-16	DET board
190	220K	V-16	DET board
191	1M	V-8	Final compt.
192	150	V-17	AUD board
193	100	Q-12	Conv. compt.
194	47K	V-18a	MIC board
195	6.8M	V-18a	MIC board
196	6.8M	V-19b	SIDET board
197	330K	V-18a	MIC board
198	500 var	V-19a	Side control
199	330K	V-18b	MIC board
200	470 $\frac{1}{2}$ W 5%	V-15	BFO compt.
201	100	Q-11	Conv. compt.
202	330	Q-11	MIX board
203	100	Q-13	MIX board
204	100	Q-9	MIX board
205	33K	Q-5	AUD board
206	330K	Q-5	AUD board
207	5K lin var	Q-12	MIX board
208	1.5K	V-15	T-13/IF board
209		V-11	T-13
210	120	V-15	IF board
211	10K 1W 10%	V-15	IF board
212	47K 1W 10%	V-15	IF board
213	Selected	V-10	ALC board
214	100	V-8	Final compt. V-8
215	100	V-9	Final compt. V-9
216		V-3	T-16
217	1K	V-3	OSC board
218	330K	V-7	V-7 turret
219	330K	V-7	V-7 turret
220	2.2M	V-7	AVC board/J-1
221	330	V-4	V-4 socket
222	33K	V-4	V-4 socket
223	2.2M	V-3	V-7 turret

<u>Resistors</u>	<u>Value</u>	<u>Location on Schematic</u>	<u>Physical Location</u>
224	100	V-15	T-14
225	1K	V-3	V-3 turret
226	1K	V-4	SLCF
227	1M	V-5	V-5 socket
228	68	V-5	C-45
229	1K	V-5	CAL board
230	100K	V-5	CAL board
231	10K	V-5	CAL board
232	47 1/4W 10%	V-6	V-6 socket
233	100	V-10	Final compartment V-10
234	10K	V-6	Final compartment V-6
235	100	Q-2	VFO out board
236	150	V-6	V-6 socket
237	330	V-7	V-7 turret
238	33K	V-7	V-7 turret
239	1K	V-7	T-10
240	100	V-6	Final shield
241	330	V-19	SIDET board
242	100	V-8	Final compartment V-8
243	100	V-9	Final compartment V-9
244	100	V-10	Final compartment V-10
245	2 1/2W 5%	V-10	AIC board
246	1.5K	V-13b	Final compartment
247	22K	V-13b	Final compartment
248	220K	V-13b	Final compartment
249	220K	V-11	AVC board/V-11
250	68	V-11	IF board/V-11
251	8.2K	V-11	IF board
252	47K	V-11	IF board
253	1.5K	V-11	IF board/T-11
254	68K	V-12	AVC board
255	12K	V-12	IF board
256	39K	V-12	IF board
257	1.5K	V-12	IF board/T-12
258	33K	V-13a	DET board/T-12
259	36K 1/2W 5%	V-13a	DET board
260	680K	V-13a	DET board
261	33K	V-13a	DET board
262	33K	V-13a	AVC board
263	2.2M	V-13a	AVC board
264	33K	V-13a	AVC board
265	1M	V-13b	AIC board
266	10K	V-19b	AVC board
267	22M	V-14	V-14 socket
268	15K 2W 10%	V-14	V-14 socket
269	22M	V-14	V-14 socket
270	200 var	V-17	Side control
271	470	V-17	IF board
272	750 5W 10%	V-8	Near V-14
273	330K	V-14	AUD board

<u>Resistors</u>	<u>Value</u>	<u>Location on Schematic</u>	<u>Physical Location</u>
274	10	Q-7	OSC board
275	330K	V-8	AUD board
276	10K	V-2	BFO compt.
277	100	Q-13	Conv. compt.
278	100	Q-13	MIX board
279	100K	Q-13	MIX board
280	6.8M	Q-14	AMP board
281	33K	Q-15	AMP board
282	10K	Q-15	AMP board
283	2.2K	Q-15	AMP board
284	4.7K	Q-15	AMP board
285	22K	Q-15	AMP board
286	47K 2W 10%	V-12	AMP board
287	220 1W 10%	Q-6	S4
288	22M	V-11	AMP board
289	100K	V-18	V-18 socket
290	33K	Q6	Lightboard
291	100 ohm	V-3	MLX board
292	100 ohm	V-1	J-3
293	100 ohm	V-3	J-3
294	100 ohm	V-6	Final Shield

Note: All capacitors ceramic discs, unless otherwise noted.
 All capacities from .001 to .47 in μf , all capacities from .5 to 1000 in pf, unless otherwise noted.
 All resistors $\frac{1}{2}\text{W}$, 10% unless otherwise noted.

Range switch pos.	51	51.5	52	52.5	53	49.5	53.5	MHz
Range covered	50.9 51.5	51.4 52.0	51.9 52.5	52.4 53.0	52.9 53.5	49.4 50.0	53.4 54.0	MHz

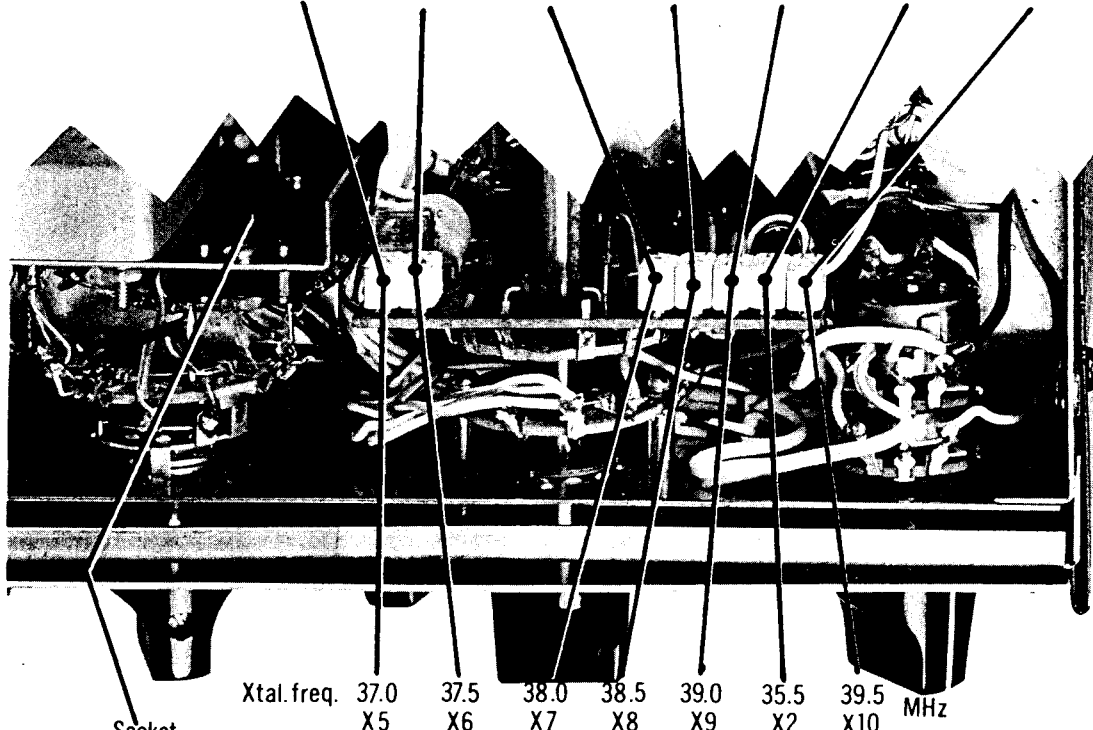

FIG.15-ACCESSORY CRYSTAL VIEW

XII. ACCESSORY INFORMATION

This section lists and gives information on accessories for the TR-6.

A. MS-4

Drake Model MS-4 matching speaker recommended. See section V,A.3.

B. POWER SUPPLIES

Drake Models AC-4, DC-4, and DC-24 recommended. See section II, D.

C. RV-6

The Drake Model RV-6 remote VFO allows separation of transmitting and receiving frequency by as much as 600 KHz. Either the receiving frequency or the transmitting frequency or both may be controlled by the remote VFO, or the RV-6 may be switched off for normal transceiver operation.

D. FF-1

The Drake Model FF-1 fixed frequency adapter allows crystal controlling either the transmitting or the transceiving frequency (switch selected) of the TR-6. The FF-1 is a very compact unit which mounts underneath the TR-6 cabinet and plugs into the RV-6 socket (J-2) without increasing the overall height of the transceiver.

E. 9-NB

The Drake Model 9-NB noise blanker is the most effective weapon yet against most types of noise. It is especially effective on automobile ignition noise. The 9-NB mounts inside the TR-6 cabinet and connects into the TR-6 circuitry by means of a plug and mating jack on top of the TR-6 chassis (J-11).

The 9-NB incorporates a 10 KHz wide IF filter in its circuitry. This filter may be utilized for AM reception by placing a 220 ohm resistor across the AM filter terminals on the TR-6. The TR-6 comes with this resistor already installed.

Note that the 9-NB must not be used in mobile installations where the positive battery terminal is grounded.

F. IF FILTERS

The following accessory IF filters are available for the TR-6:

AM filter: 6 KHz bandwidth (at 6 dB).

CW filter: .3 KHz bandwidth (at 6 dB).

LSB filter: specifications identical to the USB filter supplied with the TR-6 (see section II, B).

Sockets for plugging in the accessory filters are provided in the TR-6. The sockets are labeled so that the filter switch on the front panel will give correct indication.

G. RANGE CRYSTALS

Accessory plug-in crystals are available for those ranges for which crystals are not supplied with the TR-6.

Figure 15 shows the proper socket location for each accessory crystal.

H. MMK-3

The MMK-3 mobile mounting unit aids in mounting the TR-6 in an automobile. (See section V, D.)

I. 2-M CONVERTER

The Drake Model SC-2 2 meter receiving converter is designed for use with the TR-6. Refer to figure 7 and Section IV, paragraph C, 5.

J. TV-1000-LP

The TV-1000-LP is a low pass filter designed to eliminate interference in difficult TVI cases. The TR-6 can be used on frequencies up to 52 MHz when a TV-1000-LP has been installed.

XIII. INTERFERENCE TO OTHER SERVICES CAUSED BY OPERATING THE TR-6

In locations where an RF signal is radiated with a power of several hundred watts in the immediate vicinity of a receiving installation which works with received signals of 1/10 of a billionth of a watt of power, interference is possible. The situation just described is typical for a ham transmitter being operated in a neighborhood of TV watchers. The problem intensifies with decreasing difference between ham transmitter and TV receiver frequencies (e.g. 6 meter transmitter and low channel TV receiver). In the following, causes of interference and possible cures will be discussed.

Three different causes of TVI can be distinguished. The first one can be identified by the term "harmonic radiation" and is caused by a faulty ham transmitter. The second one to be called "fundamental overload", is caused by a faulty TV receiver. The third kind to be identified as "third source interference", is caused by a non-linear device within close range of both the ham transmitter and TV receiver.

A. HARMONIC RADIATION

This interference is caused by spurious radiation from the ham transmitter, the spurious frequency being within or near the passband of either the TV receiver's front end or possibly some other stage (I.F., video). This spurious radiation is especially strong at the harmonics of the transmitter fundamental frequency, but other spurious output can be generated in transmitters employing mixers or frequency multipliers in the signal path. Harmonics can also be generated in faulty transmitting antennas or diode-type output monitors.

The TR-6 has been designed to minimize this type of interference so that it can be considered essentially TVI-proof in all but extreme fringe areas of a TV station. If TVI is encountered in such areas, the Drake TV-1000-LP filter should be installed at the TR-6 antenna jack. This filter suppresses all radiation above 52 MHz and thus protects all TV channels from this kind of interference.

B. FUNDAMENTAL OVERLOAD

This interference is caused by the fundamental output of the ham transmitter penetrating into the TV receiver's front end or possibly some other stage due to insufficient protection. If a sufficiently strong signal appears across a non-linear device in the TV receiver (usually the RF stage or a mixer), it may:

1. desensitize the TV receiver so that the wanted signal is suppressed. If the audio stages are affected, envelope detection takes place causing audio interference.

2. generate harmonics of the transmitter frequency which in turn fall within or near the passband of the TV receiver's front end or possibly some other stage, causing interference.
3. mix with some other strong signal (local BC or TV station) also present in the front end of the TV receiver, which is called "intermodulation". The intermodulation products then affect the TV receiver's front end or other stages.

The cure for this type of interference is to prevent the transmitter's signal from penetrating into the TV receiver. In the most common case, namely front end overload, a Drake TV-300-HP filter should be installed at the antenna terminals of the TV receiver. This filter suppresses all signals below 52 MHz and thus protects the TV receiver's front end from overload by transmitters operating below 52 MHz.

In the case of radiation into the IF, video or audio stages of the TV set, the interference must be eliminated by proper shielding, RF bypassing or traps at the affected circuitry.

C. THIRD SOURCE INTERFERENCE

This interference is also caused by the fundamental output of the ham transmitter. If this signal is allowed to appear across any non-linear device, it will generate harmonics or intermodulation products, as the case may be. These products are reradiated to a TV receiver and thus are a potential cause of TVI.

Such non-linear devices can include: rusty drainpipes, defective telephone wiring or rusty antenna installations, transistor radios (including car radios), TV sets connected to any antenna, crystal sets, field strength meters employing diodes, and a variety of other sources.

A TV receiver employing semiconductor devices in its front end can cause this kind of interference even (and especially) with the set turned off. Cases are known where discarded TV receivers stored in basements a block away with rabbit ears extended caused TVI in an entire neighborhood.

The cure for this kind of interference is to eliminate the non-linear device after it has been tracked down (which usually is the hardest part of the job). In the case of a TV receiver, the installation of a Drake TV-300-HP at the interfering TV set is recommended.

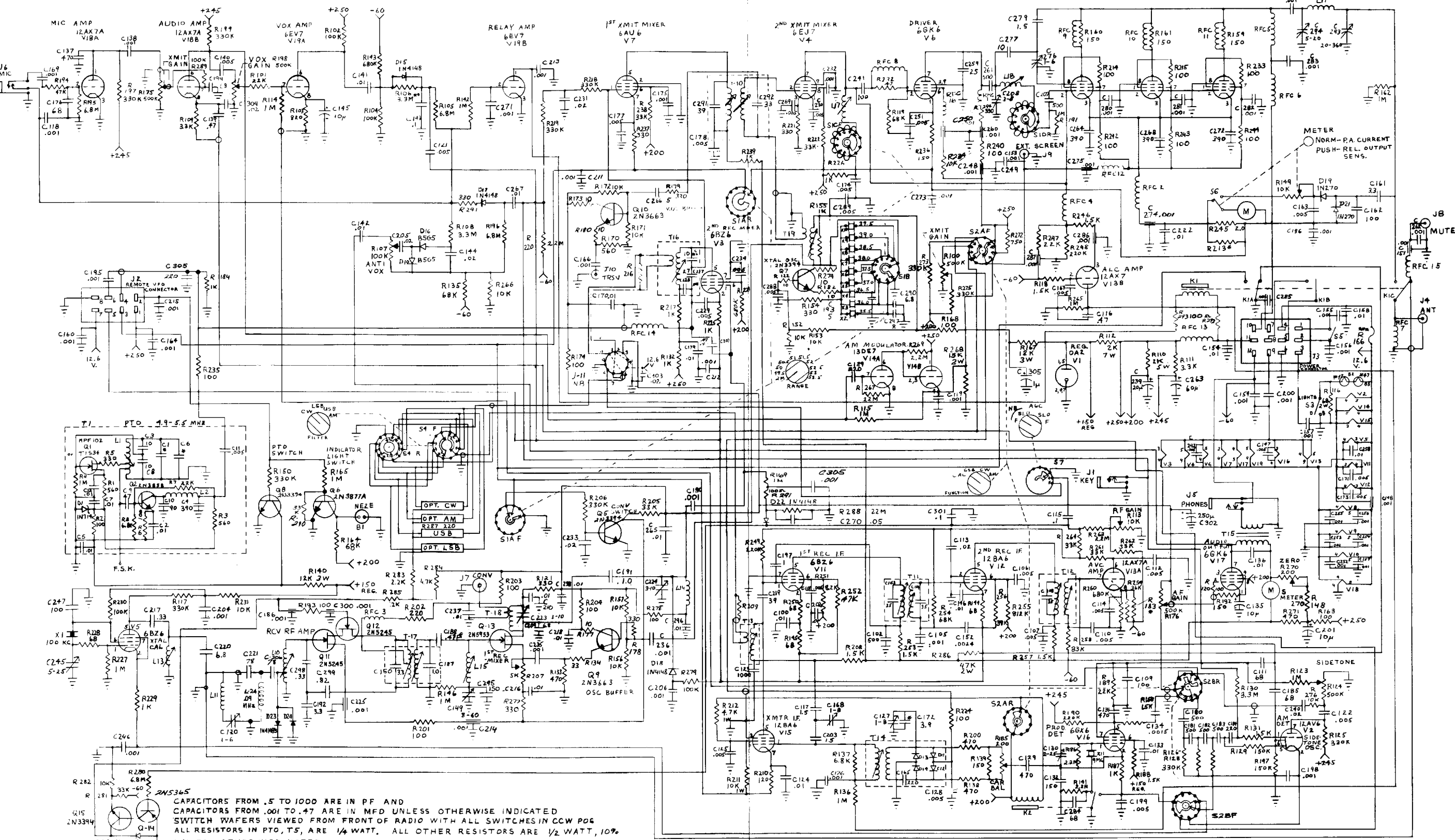

CAPACITORS FROM .5 TO 1000 ARE IN PF AND CAPACITORS FROM .001 TO .47 ARE IN MFD UNLESS OTHERWISE INDICATED SWITCH WAFERS VIEWED FROM FRONT OF RADIO WITH ALL SWITCHES IN CCW POS ALL RESISTORS IN PTO, T5, ARE 1/4 WATT. ALL OTHER RESISTORS ARE 1/2 WATT, 10% UNLESS OTHERWISE NOTED

* VALUE SELECTED IN PRODUCTION
 ** ADJUST TO CHANGE VOX HOLDING TIME
 *** 1/2" #26 TINNED COPPER WIRE

J2 AND J3 PINS VIEWED FROM OUTSIDE
 GANGED SWITCHES: S1- BANDSWITCH
 S2- FUNCTION SWITCH
 S5- PWR. ON RA1

FIG 16 SCHEMATIC DIAGRAM
 MODEL TR-6 TRANSCEIVER 012720

STANDARD WARRANTY

R. L. DRAKE COMPANY warrants each new radio product manufactured by it to be free from defective material and workmanship and agrees to remedy any such defect or to furnish a new part in exchange for any part of any unit of its manufacture which under normal installation, use, and service discloses such defect, provided the unit is delivered by the owner to us or to our authorized radio dealer or wholesaler from whom purchased, intact, for our examination, with all transportation charges prepaid to our factory, within ninety days from the date of sale to original purchaser and provided that such examination discloses in our judgement that it is thus defective. Should a malfunction be suspected, write in detail to our Service Department for suggestions concerning the operation, repair or return of your unit if it should prove necessary.

This warranty does not extend to any of our radio products which have been subjected to misuse, neglect, accident, incorrect wiring not our own, improper installation, or to use in violation of instructions furnished by us, nor extend to units which have been repaired or altered outside our factory, nor in cases where the serial number thereof has been removed, defaced or changed, nor to units used with accessories not manufactured or recommended by us.

Any part of a unit approved for remedy or exchange hereunder will be remedied or exchanged by the authorized radio dealer or wholesaler without charge to the owner.

This warranty is in lieu of all other warranties expressed or implied and no representative or person is authorized to assume for us any other liability in connection with the sale of our radio products.

The R. L. DRAKE COMPANY reserves the right to make any improvements to its products which it may deem desirable without obligating itself to install such improvements in its previously manufactured products.