



Front view of the Kenwood TS-900 s.s.b. transceiver. A small door on the left side of the cabinet conceals the Mic Gain and VOX Gain controls. The lever switches below the meter are for Send/VOX/Receive, Noise Blanker On/Off, RIT On/Off, Crystal Controlled Channel 1 or 2, and AGC Off/Fast/Slow. The RIT control is to the right of the main tuning knob. In the space above the v.f.o. dial can be seen two of the three illuminated warning legends: RIT and T MUTE.

## CQ Reviews:

# The Kenwood TS-900 SSB Transceiver

BY RICHARD A. ROSS,\* K2MGA

**F**OR the past several months it has been our good fortune to have the use of one of the Kenwood TS-900 SSB Transceivers manufactured in Japan and imported to the USA by Henry Radio of California. Good fortune indeed that this rock-solid reliable rig was loaned to us by Mary Silva of Henry Radio without whose forbearance we might not have had occasion to enjoy the TS-900 for as long as we have. You might term this evaluation a "one-year-later" report since that's how long the '900 has been under the scrutiny of this reviewer and others.

With few exceptions, the TS-900 incorporates as many desirable operating and technical features in a single rig as any discriminating amateur could ask: noise blanker, semi-break-in c.w., 500 Hz c.w. filter option, RIT, FSK provisions, phone patch connections, full metering, crystal control for net operation, 25/100 Hz calibrator, 15 MHz WWV reception, full 80-10 meter amateur band coverage with all crystals included, dual AGC systems, selectable AGC speed, plug-in modular construction and many more subtle niceties which continually disclose themselves as one gets to know the rig.

### Receiver Circuitry

Let's begin our trek through the TS-900 with a look at the block diagram, fig. 1, which shows a double conversion transceiver. On receive,

signal from the antenna is first passed through a variable attenuator to a dual gate MOSFET r.f. amplifier and then to the heterodyne mixer, also a dual-gate MOSFET, where it is mixed with the amplified output of a band-switched crystal controlled oscillator to produce the first i.f. range of 8.895 to 8.395 MHz. For example on 14.000-14.500 MHz, the heterodyne crystal frequency is 22.895 MHz yielding the 8.895 MHz to 8.395 MHz difference frequency range (other heterodyne oscillator frequencies are shown in fig. 1). The output of the heterodyne mixer is fed to the input of the v.f.o. mixer through a band-pass filter and is tuned over the 8.895 to 8.395 MHz range by means of a varicap diode whose applied voltage is varied by a pot ganged to the v.f.o. In the v.f.o. mixer the amplified v.f.o. output of 5.500 to 5.00 MHz is subtracted from the first i.f. range to yield the 3.395 MHz second i.f.

The 3.395 MHz signal is then fed to the Noise Blanker board where it is filtered and amplified by a dual gate MOSFET and fed to one of three diode-switch-selected crystal lattice filters for u.s.b., l.s.b. or c.w. Two dual gate MOSFET i.f. stages follow the filters and feed the 4-diode balanced mixer. The carrier oscillator (common to both transmit and receive) uses diode-switch selection of the desired carrier crystal: 3394.15 kHz for c.w., 3395 kHz for s.s.b., 3397.125 kHz for FSK Space (on transmit, Mark is accomplished by diode-switching a short across two small capa-

\*Editor, CQ



Fig. 1—Block diagram of the Kenwood TS-900 s.s.b./c.w. transceiver.

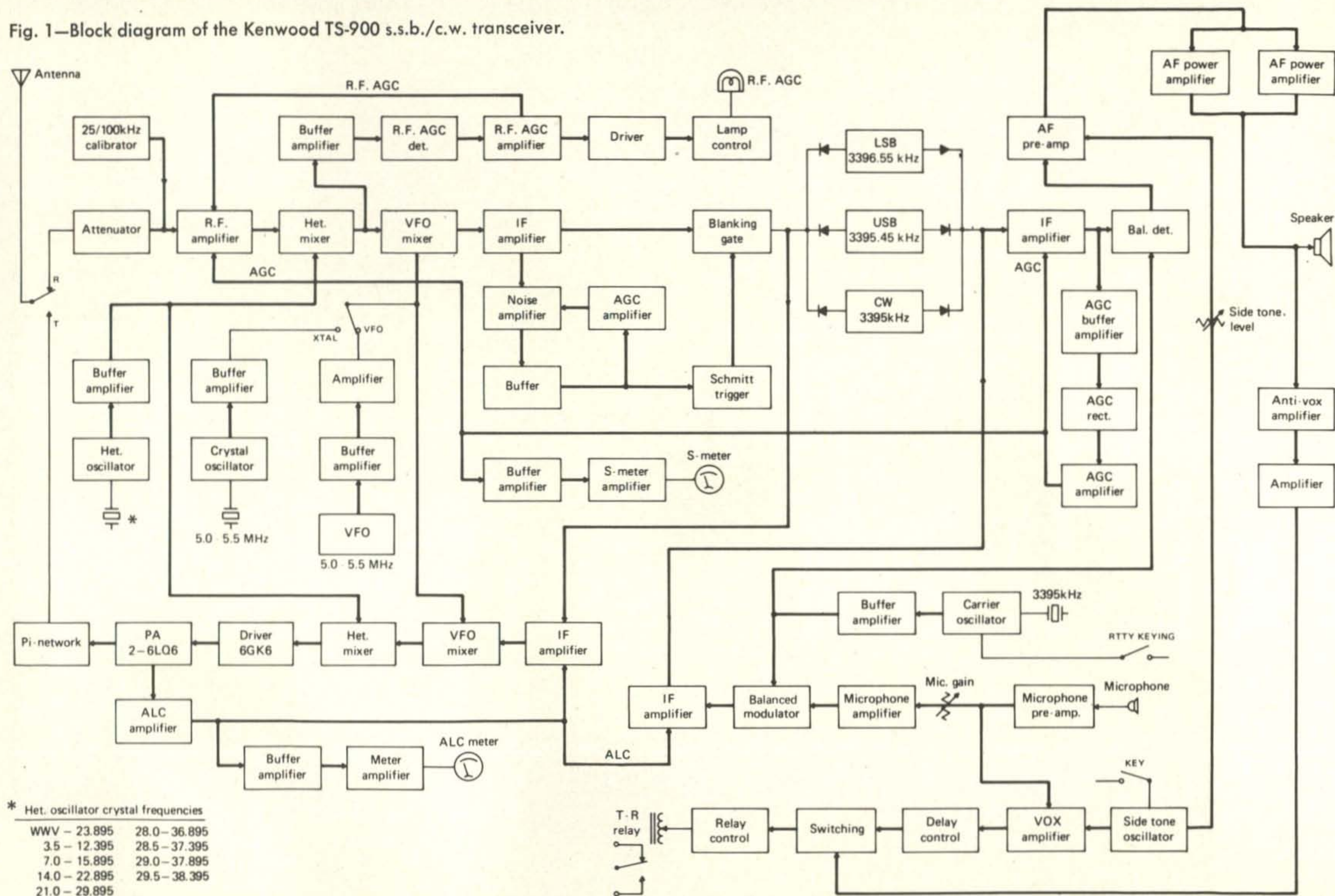

\* Het. oscillator crystal frequencies

WWV - 23.895	28.0 - 36.895
3.5 - 12.395	28.5 - 37.395
7.0 - 15.895	29.0 - 37.895
14.0 - 22.895	29.5 - 38.395
21.0 - 29.895	



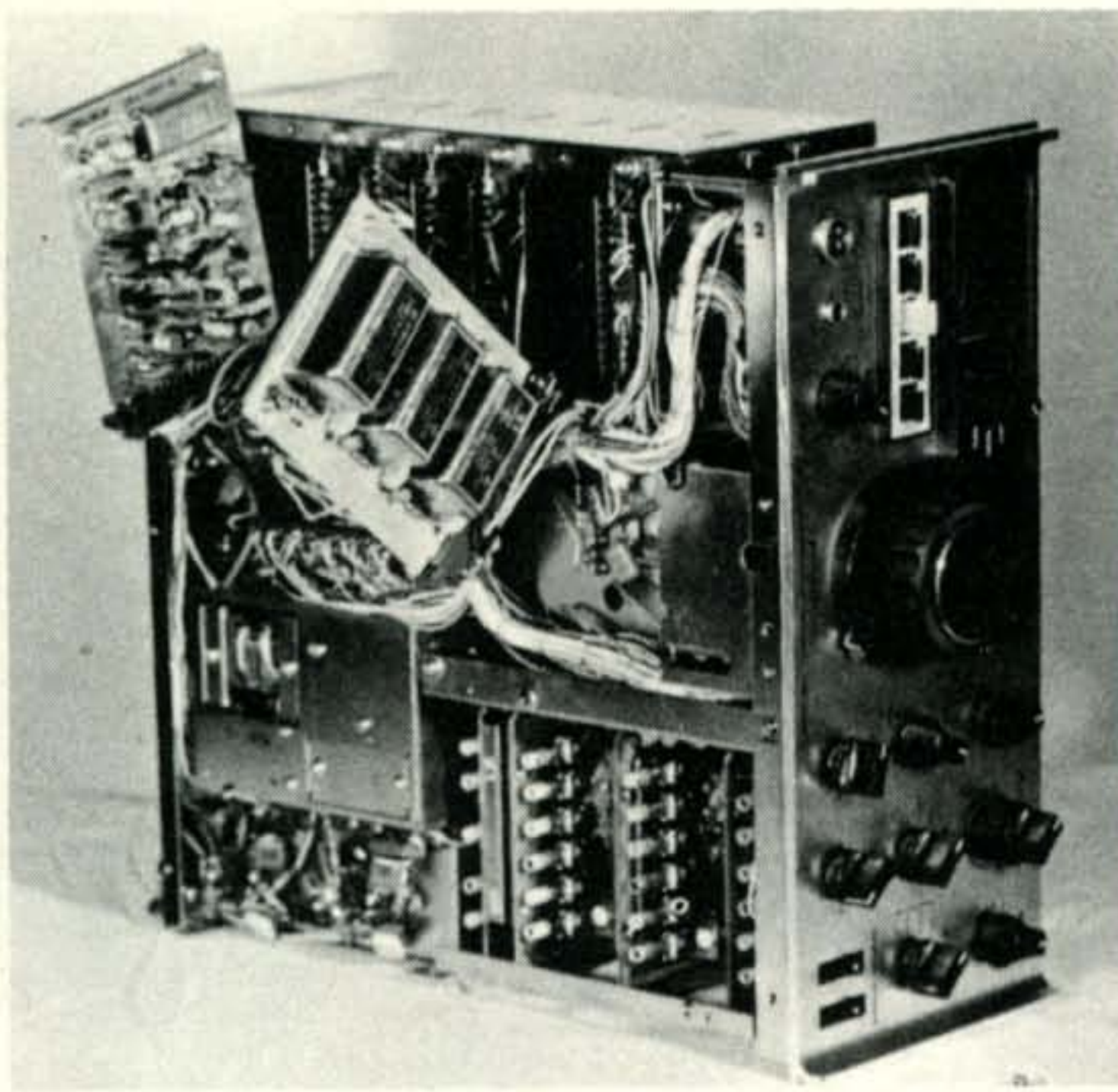

For in-circuit testing of circuit modules the PC boards are unplugged from their sockets, the sockets are hinged out from the bottom of the rig, and the PC boards are re-inserted.

citors in series with the FSK crystal). Audio output from the balanced mixer is fed to the audio amplifier string which includes a low pass filter to shape the audio response; the 8 ohm speaker output is transformerless using a complimentary pair of power transistors. 600 ohm output for phone patch operation is provided through an 8 ohm to 600 ohm transformer from the 8 ohm speaker line.

### AGC Systems

Two independent a.g.c. systems are incorporated in the TS-900. A conventional system picks up signal voltage from the output of the second i.f. amplifier, amplifying and detecting it and applying the amplified a.g.c. signal to the second i.f. string and r.f. amplifier.

Should a strong signal be present outside the receiver's i.f. passband, strong enough to cause overload of the r.f. amplifier or intermodulation, a second a.g.c. system is activated. This system, called "RF AGC," samples signal at the output of the bandpass filter preceding the v.f.o. mixer, detects and amplifies it to provide

an a.g.c. voltage, and applies the control voltage to the same gate of the r.f. amplifier MOSFET as the conventional a.g.c. The conventional a.g.c. voltage is applied through a steering diode.

The action is as follows: A strong signal within the receiver passband activates the regular a.g.c. loop. The r.f. a.g.c. is inactive if no strong signal is present *outside* the passband. If a strong signal appears outside the passband, the normal a.g.c. loop will not "see" it, but the r.f. a.g.c. will since it samples signal *before* i.f. selectivity is introduced. The r.f. a.g.c. thus reduces the gain of the r.f. amplifier, preventing overload or intermodulation.

A signal lamp on the front panel lights when the r.f. a.g.c. is working but extinguishes when the very strong off-frequency signal is actually tuned in. This occurs because as the strong signal enters the i.f. passband, it is "seen" by the conventional a.g.c. which in turn reduces the gain of the r.f. amplifier. Since the signal then reaching the r.f. a.g.c. loop is then reduced below its operating threshold, the r.f. a.g.c. is disabled, and the warning lamp extinguishes. R.f. a.g.c. voltage is prevented from reaching the i.f. stages through the conventional a.g.c. line because of the steering or blocking diode. See figure 2.

### Noise Blanker

The TS-900 noise blanker uses a balanced gate arrangement to open the 3.4 MHz signal path for the duration of a noise pulse. Broadband 3.4 MHz i.f. input from the v.f.o. mixer is first fed through a half-lattice crystal filter having a bandwidth of about 10 kHz to restrict blanker operation to noise pulses in close proximity to the tuned frequency. A two-stage IC amplifier taking signal from the filter output is controlled by a relatively slow-attack a.g.c. system which allows the fast-rise-time noise pulses to be amplified before the a.g.c. begins to act. These pulses are then shaped and drive a Shmitt trigger which biases the gating diodes off for the duration of the noise pulse. In operation the blanker is extremely effective on impulse noise, though where the pulse noise level is low its effectiveness diminishes.

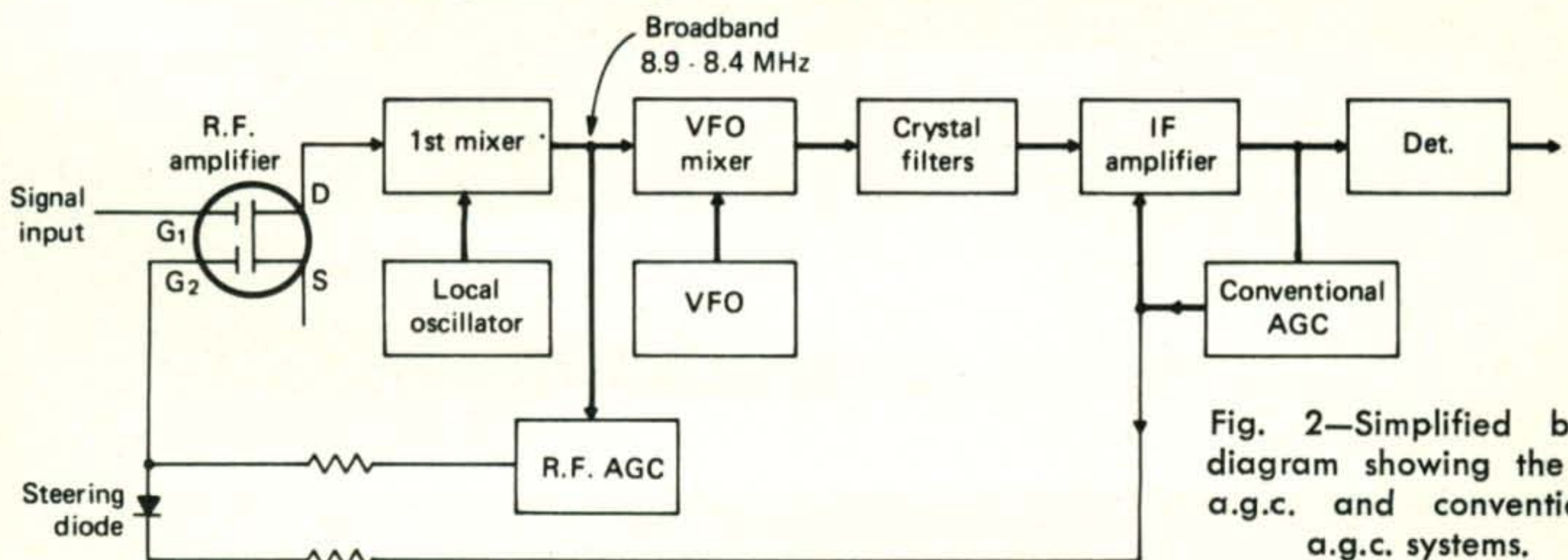

Fig. 2—Simplified block diagram showing the r.f. a.g.c. and conventional a.g.c. systems.



## Transmitter Circuitry

The transmitter is quite conventional in most respects. On s.s.b. a JFET provides high impedance mic input and is followed by two bipolar pre-amp stages which provide audio to the 4-diode balanced modulator. Carrier is provided by the same carrier oscillator as on receive. The balanced modulator output drives a MOSFET i.f. amplifier which is a.l.c. controlled. The 3395 kHz d.s.b. signal from the i.f. amplifier feeds the diode-selected crystal-lattice filters which produce an s.s.b. signal.

C.w. operation is accomplished by unbalancing the balanced modulator by applying a d.c. bias through a carrier level adjust pot. Mic pre-amp circuits are disabled. Keying is achieved by keying the sidetone oscillator whose output operates the VOX circuit. Sidetone is also applied through a level control to the receiver audio section for monitoring.

The remainder of the transmitter circuitry is straightforward; a stage of i.f. amplification after the filters, v.f.o. mixer producing 8.895-8.395 MHz signal output which is mixed again with the heterodyne oscillator output to yield the operating frequency. Output from the heterodyne mixer drives a 6GK6 which in turn drives a pair of 6LQ6's in parallel as power amplifiers.

A.l.c. is of the amplified type with the a.l.c. amplifier sampling PA grid current amplifying and applying corrective bias to the two transmitter i.f. amplifiers. A.l.c. voltage is also amplified and metered as an indication of correct or excessive mic gain and also for driver tuning adjustment.

A few words about the installation of the optional 500 Hz c.w. filter: As delivered the TS-900 uses the upper sideband filter for u.s.b. and c.w. on both transmit and receive though on c.w. the 3394.15 kHz carrier crystal is used for transmit and 3395 kHz for receiver b.f.o., meaning that the dial pointer will indicate 850 Hz lower than the actual received and transmitted frequency. When the optional c.w. filter is used these two crystals are reversed (3394.15 kHz b.f.o.; 3395 kHz carrier) meaning that the received and transmitted frequencies coincide with the dial pointer. This reversing is accomplished by unplugging, reversing and re-plugging a flat 6-conductor plug and socket under the chassis at the time of installation of the c.w. filter.

## Metering

In addition to the a.l.c. metering mentioned previously a front panel switch permits reading PA plate current, r.f. output (relative), and PA plate voltage. On receive, the meter automatically reads signal strength. PA plate current is measured by reading the voltage drop across 1 ohm PA cathode resistors and amplifying this voltage which is then read by the meter.

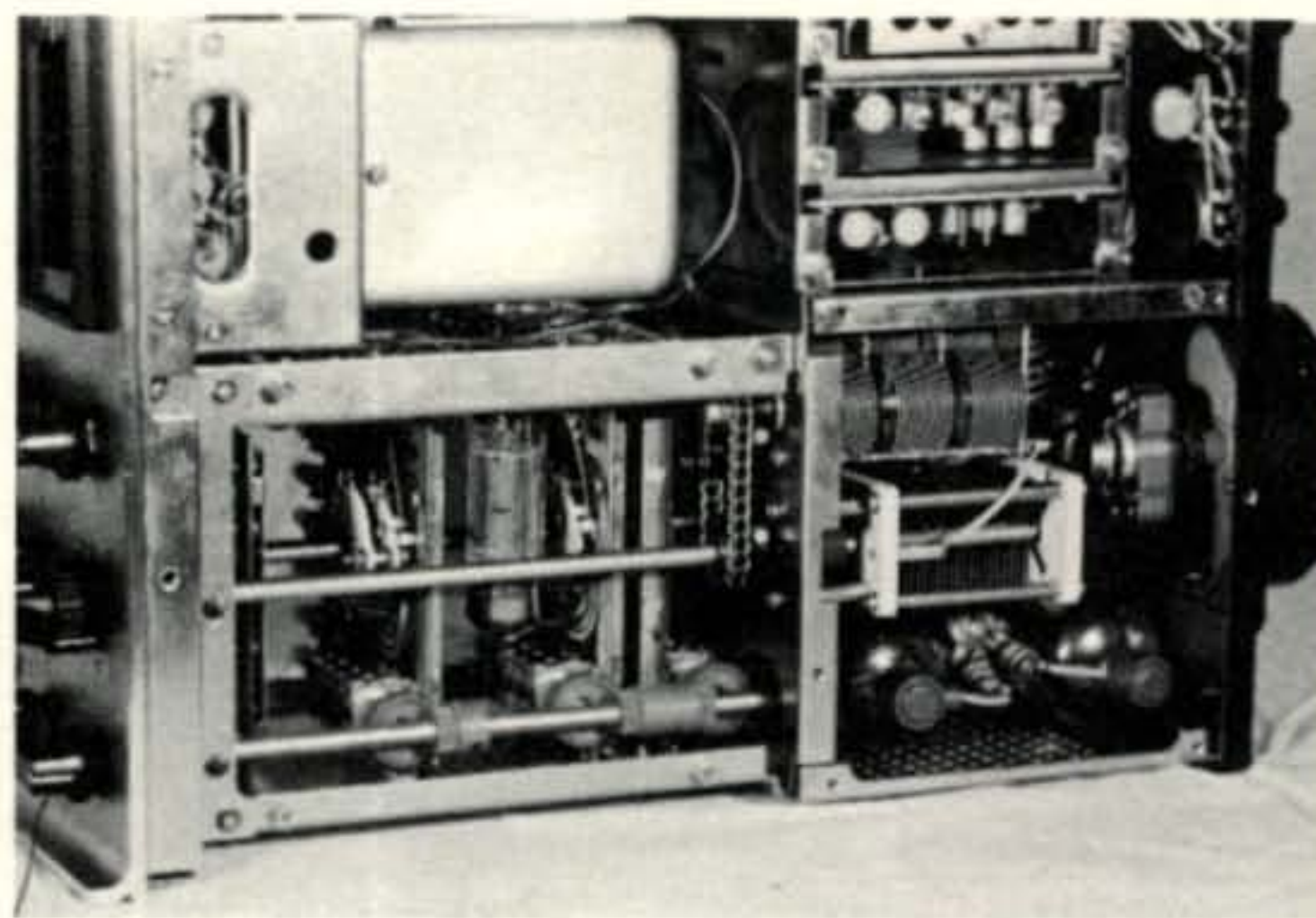

Close-up of the driver and PA compartments, viewed from the top. Right angle gears drive variable capacitors for receiver r.f. amplifier and transmitter driver tuning. At the center, the chain/sprocket drive for the PA loading is visible.

R.f. output is measured through a voltage divider across the 50 ohm transmitter output, and detected by a diode. PA plate voltage is read across a voltage divider at the PA B-plus feed point.

## RIT and Indicator Lights

Receiver incremental tuning is accomplished by applying and varying the bias on a varicap diode paralleling the v.f.o. tuning capacitor. The diode is always connected, but is biased only when the front panel RIT switch is engaged and the transceiver is in the receive mode. When the RIT switch is engaged, a warning legend "RIT" illuminates in the space above the tuning dial and remains on until the switch is disengaged.

On the front panel RIT control pot (which has a tuning range of  $\pm 2$  kHz approx.) is another switch at the full counter clockwise position which disables the v.f.o. completely and energizes a crystal controlled oscillator in its place. Two crystals in the 5.0-5.5 MHz range may be inserted in sockets provided internally and selected by a front panel switch for net operation or other purposes requiring precisely repeatable frequencies. The illuminated v.f.o. dial pointer extinguishes when crystal control is used.

Other lighted legends also appear above the v.f.o. dial: the RF AGC warning light and a T MUTE light indicating that the driver and PA filaments are switched off by their front panel switch as they might well be when just monitoring the bands.

## Construction

This reviewer takes particular delight in fine mechanical devices in addition to fine electronic devices. For this reason among others, the Kenwood TS-900 has been a pleasant review to



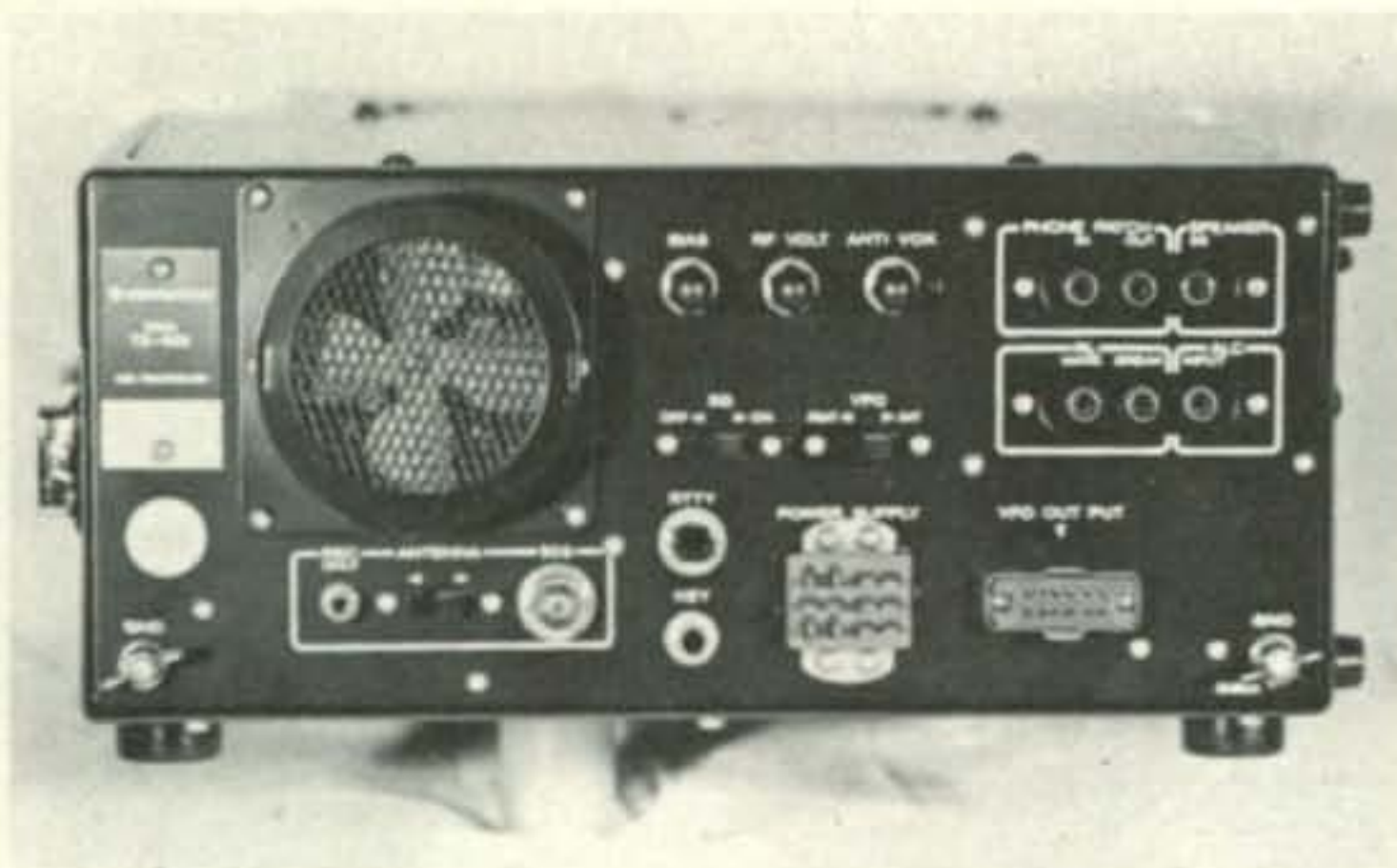

Rear view of the TS-900 shows a variety of connectors: speaker and phone patch at upper right, relay contacts and a.l.c. below. Right to left along the bottom are: ground post, external v.f.o. connector, power connector, RTTY and c.w. key jacks, SO-239 antenna connector, antenna selector switch, receiver-only antenna jack, and another ground post. Above the key and power connectors are slide switches for PA screen supply on/off, and remote/internal v.f.o. At the top center adjacent to the fan are adjustments for PA bias, r.f. voltmeter, and anti-vox.

write. The TS-900 is a well-constructed, well-thought-out and smoothly functioning piece of equipment.

The package measures  $12\frac{5}{8}$ " wide  $\times$   $5\frac{1}{2}$ " high  $\times$   $12\frac{5}{8}$ " deep and weighs a little over 26 pounds. The front panel is satin-finished extruded aluminum with moulded satin black high-impact plastic escutcheons for the dial and S-Meter, and for a bank of five lever switches. The cabinet is steel, finished in a rugged black textured paint, and is designed for several degrees of access to the interior. A removable "hinged" top lid is secured by snap fasteners, (and a single screw for shipping or transporting), and allows access to most internal adjustments. For more extensive work top-side, removal of seven screws allows the top portion of the cabinet to be swung aside on split butt hinges. Removal of several more screws removes the cabinet bottom.

The TS-900 is largely modular in its construction, with most circuitry on PC boards which plug into high quality PC edge connectors. These boards are closely packed, but well shielded from each other as each fits into its own metal compartment. Service is facilitated by a swing out arrangement on the PC board connectors permitting the board to be removed, the connector swung out from the bottom of the set, and the board reinserted in the connector. Thus access is available to both sides of the board while the set is live.

In addition to the shield compartments for boards, several top shields cover various compartments, and also identify the boards and their associated adjustments, the most commonly used of which are accessible through holes in the shields.

The PA is conventionally wired and a permanently installed part of the structure. Driver tuning is accomplished by means of several unusually small multi-gang variable capacitors which are ganged by means of nylon bevel gears to mating gears on the driver tuning shaft. PA loading is concentrically located on the PA tuning control shaft, and the loading capacitor is driven by a rugged chain and sprocket arrangement. Operation of these controls is smooth and very positive, particularly in view of the quantity of mechanical devices involved.

V.f.o. tuning is very light, but with adjustable weighing. The machined black anodized aluminum tuning knob is quite heavy and gives excellent flywheel type tuning along with great smoothness. The large knob is one of the better ones in use today on any amateur transceiver.

A 3" dia. shielded fan-type blower is mounted at the rear of the PA compartment for cooling. Unfortunately the noise level from the fan is rather high and the fan runs continuously as long as the power switch is on even if the driver and PA filaments are not powered, something we found annoying.

The bandswitch wafers are all high quality ceramic types, a welcome feature. Two switches are used: one to select the band — WWV, 80, 40, 20, 15 or 10; the other to select the  $\frac{1}{2}$  MHz segment of 10 meters desired — 28.0, 28.5, 29.0 or 29.5.

External connections are provided at the rear for a multitude of purposes: speaker, 600 ohm phone patch input and output, relay make or break, a.l.c. input, RTTY keying input, key jack, 50 ohm antenna for both receiving and transmitting (SO-239), a receiver-only antenna input (switch selected, phono jack), power supply 12 conductor locking Jones plug and special 12 conductor jack for connection of an optional external v.f.o., model VFO-900. In addition, two rugged ground posts are provided at the rear.

Another convenient feature is the inclusion of slide switches for disabling the driver and/or PA screens for neutralization.

### Performance

In all respects which we could ascertain, the TS-900 equaled or exceeded the manufacturer's claimed specifications. The figures in parentheses below are our measurements; the first figures are those claimed.

*Receiver:* SENSITIVITY —  $0.5 \mu\text{V}$  for 10 db S+N/N ( $<0.25 \mu\text{V}$  on s.s.b.;  $<0.125 \mu\text{V}$  on c.w.). INTERNAL SPURIOUS—Not rated (none on 40-10m.; 3737.5 kHz  $.03 \mu\text{V}$  equiv.; 3799, 3899 and 3999 kHz  $.01 \mu\text{V}$  equiv.). A.V.C. FIGURE OF MERIT — Not rated ( $0.1 \mu\text{V}$  —  $1 \mu\text{V}$  change, 4 db;  $1 \mu\text{V}$  to  $10,000 \mu\text{V}$  change, 1db!).

[Continued on page 67]



value, as opposed to a commercial piece of equipment. It looks as if the hard laws of economics are making appliance operators of us all." ■

### CQ Reviews Kenwood TS-900 [from page 28]

**FIRST IF REJECTION**—45 db (70 db min >85 db on 40 and 10). **SECOND IF REJECTION**—(Not measurable). **IMAGE RATIO** — >50 db down from output signal (−54 db). **STABILITY** —100 Hz during any 15 min period after warmup (20 Hz), ±2kHz during first hour after 1 min. warmup (±0.5 kHz). **S-METER**—(S-9=26  $\mu$ v 80-15, 10m. S-9=45  $\mu$ v. 6 db per S-unit and correctly calibrated to +40 db). **FRONT END DE-SENSING FROM STRONG ADJACENT SIGNAL** — (1 $\mu$ v @ 14.300 is de-sensed 1½ db by 100,000  $\mu$ v 10 kHz away). **SELECTIVITY**—SSB 2.2 kHz 6 db (2.4 kHz), 4.4 kHz 60 db (4.4 kHz); c.w. 0.5 kHz 6 db (0.5 kHz), 1.5 kHz 60 db 1.2 kHz).

**Transmitter:** SSB PEP OUTPUT-150 watts into 50 ohms (160 w. except on 10m. 150 w.); c.w. output—100 watts nominal (with 230 w. input, 150 w. output 80, 40, 20; 135 on 15 and 125 on 10). **CARRIER SUPPRESSION**—>45 db down from output (−60 db). **SB SUPPRESSION**—Unwanted sideband −40 db from output (at 1 kHz, USB −44db; LSB −40 db). **HARMONIC RADIATION**—40 db down from output (50 db or better on all bands). **SPURIOUS EMISSIONS**—(None detectable within amateur bands when properly neutralized).

### Conclusions

As the reader might suspect, we found the Kenwood TS-900 to be an excellent all-around piece of equipment. Only a few small additions would be worthwhile improvements to the operating convenience of the rig. The most significant addition we'd like to see is a provision to use the 2.2 kHz i.f. filter for c.w. reception when band conditions permit. The optional 0.5 kHz filter is excellent under crowded conditions but too sharp for casual operation. Also, we would have liked to see a quieter blower switched on along with filament voltage.

But all in all the TS-900 is the most sophisticated transceiver we've reviewed to date. With the rugged leather carrying handle on its side and rubber feet on the opposite side, it's an easily carried full feature station. Power supplies are available for home station or mobile use, the former being in a matching package with built-in speaker.

The Kenwood TS-900 is imported and distributed by Henry Radio of Los Angeles, California and is priced at \$795.00. The PS-900 a.c. power supply is \$120.00; the DS-900 mobile supply is \$140.00. The VFO-900 is \$195.00. The optional CW-900 c.w. filter is \$45.00.

—K2MGA

## Free Classified Ads

Your classified ad may be run Free of Charge in **THE ELECTRONIC FLEAMARKET** -- a brand new monthly publication that hits the mail on February 10th.

This offer is good for all CQ subscribers every month. Please limit ads to thirty words or six lines, and not more than two ads per month. You can buy, sell, swap or advertise for QSLs. Your ad may cover ham gear, CB gear, test equipment, stereo, or anything else an electronic hobbyist may find of interest.

Remember, this service is absolutely *free* to subscribers who use the coupon below (or a reasonable facsimile thereof). **THE ELECTRONIC FLEAMARKET** will be read by thousands of electronic hobbyists, so don't miss out.

After all, could the price be better?

---

### ELECTRONIC FLEAMARKET

14 Vanderventer Avenue  
Port Washington, NY 11050

Please run the classified ad listed below in the first available issue:

---

---

---

---

---

---

---

---

\*\*\*

Name \_\_\_\_\_

Address \_\_\_\_\_

City \_\_\_\_\_ State \_\_\_\_\_ Zip \_\_\_\_\_