

**TM 11-5820-923-12**

---

**TECHNICAL MANUAL**

**OPERATOR'S AND ORGANIZATIONAL  
MAINTENANCE MANUAL**

**RADIO SET AN/GRC-213  
(NSN 5820-01-128-3935)**

This copy is a reprint which includes current  
pages from Changes 1 and 2.

---

**HEADQUARTERS, DEPARTMENT OF THE ARMY  
14 FEBRUARY 1986**



CHANGE

No. 2

HEADQUARTERS  
DEPARTMENT OF THE ARMY  
Washington, DC, 1 September 1990

**Operator's and Organizational  
Maintenance Manual**

**AN/GRC-213  
(NSN 5820-01-128-3935)**

TM 11-5820-923-12, 14 February 1986, is changed as follows:

1. Remove old pages and insert new pages as indicated below. New or changed material is indicated by a vertical bar in the margin of the page. Added or revised illustrations are indicated by a vertical bar adjacent to the identification number.

<i>Remove pages</i>	<i>Insert pages</i>
A and B . . . . .	A through C/(D blank)
i and ii . . . . .	i and ii
1-1 through 1-4 . . . . .	1-1 through 1-4
2-1 and 2-2 . . . . .	2-1 and 2-2
2-15/(2-16 blank) . . . . .	2-15/(2-16 blank)
4-15 and 4-16 . . . . .	4-15 and 4-16
A-1 through A-3/(A-4 blank) . . . . .	A-1 through A-3/(A-4 blank)
C-3 and C-4 . . . . .	C-3 and C-4
C-9 and C-10 . . . . .	C-9 and C-10

2. File this change sheet in the publication for reference purposes.

Distribution authorized to the Department of Defense and DOD contractors only for official use or for administrative or operational purposes. This determination was made on 31 May 1990. Other requests for the document will be referred to Commander, US Army Communications-Electronics Command and Fort Monmouth, ATTN: AMSEL-LC-ME-P, Fort Monmouth, NJ 07703-5000.

DESTRUCTION NOTICE - Destroy by any method that will prevent disclosure of contents or reconstruction of the document.

By Order of the Secretary of the Army:

CARL E. VUONO  
*General, United States Army*  
*Chief of Staff*

Official:

THOMAS F. SIKORA  
*Brigadier General, United States Army*  
*The Adjutant General*

DISTRIBUTION:

To be distributed in accordance with DA Form 12-51-E,  
block 1452, Operator and Unit Maintenance requirements  
for TM 11-5820-923-12.

**CHANGE**

**No. 1**

HEADQUARTERS  
DEPARTMENT OF THE ARMY  
WASHINGTON, DC, 1 January 1989

**Operator's and Organizational  
Maintenance Manual**

**AN/GRC-213  
(NSN 5820-01-128-3935)**

TM 11-5820-923-12, 14 February 1986, is changed as follows:

**1. Remove old pages and insert new pages as indicated below. New or changed material is indicated by a vertical bar in the margin of the page. Added or revised illustrations are indicated by a vertical bar adjacent to the identification number.**

**Remove pages**

C-5 and C-6

**Insert pages**

C-5 and C-6

**2. File this change sheet in front of the publication for reference purposes.**

Distribution authorized to the Department of Defense and DOD contractors only for official use or for administration or operational purposes. This determination was made on 5 July 1988. Other requests for this document will be referred to Commander, US Army Communications-Electronics Command and Fort Monmouth, Attn: AMSEL-LC-ME-P, Fort Monmouth, NJ 07703-5000.

DESTRUCTION NOTICE-Destroy by any method that will prevent disclosure of contents or reconstruction of the document.

By Order of the Secretary of the Army:

CARL E. VUONO  
*General, United States Army*  
*Chief of Staff*

Official:

WILLIAM J. MEEHAN II  
*Brigadier General, United States Army*  
*The Adjutant General*

DISTRIBUTION:

To be distributed in accordance with DA Form 12-51 Operator and Unit requirements for AN/GRC-213.

**5**

**SAFETY STEPS TO FOLLOW IF SOMEONE IS THE VICTIM OF ELECTRICAL SHOCK**

**1**

**DO NOT TRY TO PULL OR GRAB THE INDIVIDUAL**

**2**

**IF POSSIBLE, TURN OFF THE ELECTRICAL POWER**

**3**

**IF YOU CANNOT TURN OFF THE ELECTRICAL POWER, PULL, PUSH, OR LIFT THE PERSON TO SAFETY USING A DRY WOODEN POLE OR A DRY ROPE OR SOME OTHER INSULATING MATERIAL**

**4**

**SEND FOR HELP AS SOON AS POSSIBLE**

**5**

**AFTER THE INJURED PERSON IS FREE OF CONTACT WITH THE SOURCE OF ELECTRICAL SHOCK, MOVE THE PERSON A SHORT DISTANCE AWAY AND IMMEDIATELY START ARTIFICIAL RESUSCITATION**

**WARNING**

Dangerous voltages exist in power lines. Do not allow antenna to touch power lines.

Antenna installation area must be free of power lines. Antenna contact with power lines during installation may cause serious injury or even DEATH to operator.

If you must erect antenna near power lines, power line poles or towers, or buildings with overhead power line connections, never put the antenna closer than two times the antenna height from the base of the power line, pole, tower, or buildings.

Tie antenna down before moving vehicle. When vehicle is in motion, do not allow anyone to stick an arm, leg, or weapon over the sides of the vehicle. If the antenna accidentally touches a power line and a leg, arm, or weapon contacts a damp bush or the ground, a serious or fatal accident can occur.

If you suspect that power lines have made accidental contact with your antenna, stop operating, rope off the antenna area, and notify your superiors.

For first aid, refer to FM 21-11.

**WARNING**

Operation in marginal weather where electrical activity is possible may be dangerous to the operator or occupants of the vehicle.

For first aid, refer to FM 21-11.

**WARNING**

Do not smoke or use flame near fuel or vehicle fuel system. Fire or explosion may occur, causing personal injury or DEATH.

**WARNING**

Dangerous rf voltages exist around antennas and antenna terminals during transmission. Protect yourself by knowing the safety procedures in TB SIG 291.

**WARNING**

Do not store lithium battery, BA-5590/U, in transit case longer than 30 days. After 30 days, the battery may discharge, overheat, and vent hazardous sulfur dioxide fumes. (See C/(D blank)

**WARNING**

When using a compressed airjet, use eyeshields to prevent severe eye injury.



## WARNING

### LITHIUM BATTERIES

A lithium battery is used in this equipment and is potentially hazardous if misused or tampered with before, during, and after discharge. The following precautions must be strictly observed to prevent possible injury to personnel or damage to equipment.

DO NOT USE unauthorized batteries or damaged batteries and dispose of any batteries showing signs of damage.

DO NOT USE lithium batteries in parallel circuitry unless the batteries or equipment are diode protected.

DO NOT short circuit.

DO NOT test for capacity or recharge.

DO NOT bypass internal fuse or replace with a fuse of a different rating.

DO NOT store in equipment during long periods when not in use.

TURN OFF the equipment immediately if you detect the battery compartment becoming unduly hot or rapidly increasing in temperature, hear battery venting (hissing sound), or smell irritating sulfur dioxide gas. Remove and dispose of the battery only after it is cool (at least 60 minutes).

DO NOT use carbon dioxide extinguishers on exposed lithium metal fires. Flood the burning material with water or use graphite type compounds or extinguishers to extinguish burning lithium.

REMOVE THE BATTERY WHEN THE EQUIPMENT DOES NOT OPERATE PROPERLY AND REPLACE WITH A NEW BATTERY.

DISPOSE OF SPENT LITHIUM BATTERIES THROUGH THE LOCAL SERVICING DEFENSE REUTILIZATION AND MARKETING OFFICE (DRMO).



Technical Manual  
 No. 11-5820-923-12

HEADQUARTERS  
 DEPARTMENT OF THE ARMY  
 Washington, DC, 14 February 1986

**Operator's and Organizational  
 Maintenance Manual**

**AN/GRC-213  
 (NSN 5820-01-128-3935)**

**REPORTING ERRORS AND RECOMMENDING IMPROVEMENTS**

You can help improve this manual. If you find any mistakes or if you know of a way to improve the procedures, please let us know, Mail your letter, DA Form 2028 (Recommended Changes to Publications and Blank Forms), or DA Form 2028-2 located in back of this manual direct to: Commander, US Army Communications-Electronics Command and Fort Monmouth, ATTN: AMSEL-LC-ME-PS, Fort Monmouth, New Jersey 07703-5000.

In either case, a reply will be furnished direct to you.

		<b>Page</b>
List of Illustrations . . . . .		iv
List of Tables . . . . .		iv
CHAPTER 1. INTRODUCTION . . . . .		1-1
Section I. General Information . . . . .		1-1
1-1. Scope . . . . .		1-1
1-2. Maintenance Forms, Records, and Reports . . . . .		1-1
1-3. Consolidated Index of Army Publications and Blank Forms . . . . .		1-1
1-4. Hand Receipt (-HR) and Related Technical Manuals . . . . .		1-1
1-5. Destruction of Army Electronics Materiel to Prevent Enemy Use . . . . .		1-4
1-6. Administrative Storage . . . . .		1-4
1-7. Reporting Equipment Improvement Recommendations (EIR) . . . . .		1-4
Section II. Equipment Description . . . . .		1-5
1-8. Purpose and Function . . . . .		1-5
1-9. Capabilities and Features . . . . .		1-5
1-10. Difference Between Models . . . . .		1-6
1-11. Equipment Specifications . . . . .		1-6
Section III. Equipment and Tools Lists. . . . .		1-10
1-12. Equipment Supplied . . . . .		1-10
1-13. Equipment Required But Not Supplied . . . . .		1-10
1-14. Special Tools and Test Equipment . . . . .		1-10

	Page
CHAPTER 2. PREPARATION FOR USE AND INSTALLATION INSTRUCTIONS . . . . .	2-1
Section I. Preparation for Use. . . . .	2-1
2-1. Unpacking . . . . .	2-1
2-2. Mounting . . . . .	2-1
Section II. Connections . . . . .	2-13
2-3. Interconnections . . . . .	2-13
2-4. Grounding Requirements . . . . .	2-15
2-5. Minimum Performance Test . . . . .	2-15
CHAPTER 3. OPERATING INSTRUCTIONS . . . . .	3-1
Section I. Controls, Visual and Audible Indicators, and Connectors . . . . .	3-1
3-1. General . . . . .	3-1
3-2. Controls and Indicators . . . . .	3-1
3-3. Audible Indicators . . . . .	3-3
3-4. Connectors . . . . .	3-4
Section II. Operation . . . . .	3-7
3-5. Operating Considerations . . . . .	3-7
3-6. Initial Checks . . . . .	3-9
3-7. initial Control Settings . . . . .	3-11
3-8. Startup . . . . .	3-12
3-9. Operation Under Normal Conditions . . . . .	3-12
3-10. Operation under Radio Silence . . . . .	3-15
3-11. Operation Under Unusual Conditions . . . . .	3-16
3-12. Shutdown . . . . .	3-16
CHAPTER 4. THEORY OF OPERATION . . . . .	4-1
4-1. General . . . . .	4-1
Section I. AN/GRC-213 General Functional Description . . . . .	4-2
4-2. AN/GRC-213 General Functional Description . . . . .	4-2
4-3. AN/VIC-1(V) Interface General Functional Description . . . . .	4-4
Section II. AN/GRC-213 Detailed Functional Description . . . . .	4-8
4-4. AN/GRC-213 Detailed Functional Description . . . . .	4-8
CHAPTER 5. OPERATOR MAINTENANCE . . . . .	5-1
Section I. Operator Preventive Maintenance, Checks, and Services . . . . .	5-1
5-1. General . . . . .	5-1
5-2. Daily Visual Inspection . . . . .	5-1
5-3. Daily Minimum Performance Test . . . . .	5-2
5-4. Weekly Battery Pack Inspection . . . . .	5-2
Section II. Operator Maintenance . . . . .	5-4
5-5. General . . . . .	5-4
5-6. Cleaning and Corrosion Control Instructions . . . . .	5-4

	Page
CHAPTER 6. ORGANIZATIONAL MAINTENANCE . . . . .	6-1
Section I. Organizational Preventive Maintenance, Checks, and Services . . . . .	6-1
Section II. Organizational Maintenance . . . . .	6-2
6-1. General . . . . .	6-2
6-2. Common Tools and Test Equipment . . . . .	6-2
6-3. Special Tools, TMDE, and Support Equipment . . . . .	6-2
6-4. Materials . . . . .	6-2
6-5. Repair Parts . . . . .	6-2
6-6. Fault Isolation . . . . .	6-2
6-7. Removal and Replacement Instructions . . . . .	6-18
6-8. Minimum Performance Test . . . . .	6-33
CHAPTER 7. PREPARATION FOR STORAGE OR SHIPMENT . . . . .	7-1
7-1. Preparation for Shipment . . . . .	7-1
7-2. Storage . . . . .	7-3
APPENDIX A. REFERENCES . . . . .	A-1
B. MAINTENANCE ALLOCATION CHART . . . . .	B-1
C. COMPONENTS OF END ITEM AND BASIC ISSUE ITEMS LISTS . . . . .	C-1
D. ADDITIONAL AUTHORIZATION LIST . . . . .	D-1
E. EXPENDABLE/DURABLE SUPPLIES AND MATERIALS LIST .	E-1

LIST OF ILLUSTRATIONS

Figure	Title	Page
1-1.	Radio Set AN/GRC-213 (2 Sheets) . . . . .	1-2
2-1.	Latching of Receiver/Exciter and Amplifier/Coupler . . . . .	2-2
2-2.	Mounting Diagram . . . . .	2-3
2-3.	NVIS Antenna Installation . . . . .	2-5
2-4.	Connecting RF Cable and Antenna Wires to Insulator . . . . .	2-7
2-5.	Use of Tape Measure to Determine Antenna Wire Length . . . . .	2-9
2-6.	Unwinding Antenna Wire from Reel Assembly . . . . .	2-9
2-7.	Attaching Halyard to Reel Assembly . . . . .	2-10
2-8.	Two-Support Dipole Antenna . . . . .	2-11
2-9.	Sloping Dipole Antenna . . . . .	2-11
2-10.	Inverted V Dipole Antenna . . . . .	2-12
2-11.	Connector/Cable Location Diagram for Installation . . . . .	2-14
3-1.	Controls and Indicators . . . . .	3-1
3-2.	Connectors . . . . .	3-6
3-3.	Antenna Comparison . . . . .	3-8
3-4.	Controls, Indicators, and Connectors for Operation . . . . .	3-10
4-1.	AN/GRC-213 Block Diagram . . . . .	4-3
4-2.	Remote Handset Operation Block Diagram . . . . .	4-5
4-3.	Retransmit Operation Block Diagram . . . . .	4-7
4-4.	Receiver/Exciter Functional Schematic . . . . .	4-9
4-5.	Amplifier/Coupler Functional Schematic (2 Sheets) . . . . .	4-12
4-6.	Amplifier-Power Supply Functional Schematic . . . . .	4-15
4-7.	Handset, Loudspeaker, and CW Key Functional Schematics . . . . .	4-17
5-1.	Battery Pack Inspection . . . . .	5-3
5-2.	Controls and Connectors for Cleaning and Corrosion Control . . . . .	5-5
6-1.	Fault Isolation Test Setup . . . . .	6-3
6-2.	Fault Isolation Flowchart (14 Sheets) . . . . .	6-4
6-3.	Removal and Installation of AN/GRC-213 Units and Cables . . . . .	6-20
6-4.	Loudspeaker Replacement . . . . .	6-27
6-5.	NVIS Antenna Replacement . . . . .	6-31
6-6.	Controls and Indicators for Minimum Performance Test . . . . .	6-34
7-1.	Disassembly . . . . .	7-2

LIST OF TABLES

Table	Title	Page
1-1.	Equipment Specifications . . . . .	1-6
1-2.	Equipment Supplied . . . . .	1-10
1-3.	Equipment Required But Not Supplied . . . . .	1-14
1-4.	Organizational Maintenance Special Tools and Test Equipment . . . . .	1-14
2-1.	Dipole Antenna Wire Length . . . . .	2-8
3-1.	Controls and Indicators . . . . .	3-2
3-2.	Connectors . . . . .	3-4

## CHAPTER 1 INTRODUCTION

### Section 1. GENERAL INFORMATION

**1-1. Scope.** This manual provides operator and organizational level operating and maintenance information for Radio Set AN/GRC-213. The AN/GRC-213 becomes fully operational for use in wheeled or tracked vehicles when it is mounted, using an installation kit (TM 11-2300-476-14&P). Figure 1-1 illustrates the AN/GRC-213. This chapter provides general reference data that includes information on physical aspects and technical characteristics, equipment supplied, equipment required but not supplied, related technical manuals, and special tools and test equipment. Chapter 2 provides preparation for use and installation instructions, including details of unpacking, assembling, mounting, cable interconnections, and grounding requirements. Chapter 3 contains operating instructions with information about the controls, indicators, and connectors on the AN/GRC-213. The operating instructions include operating considerations, initial checks and settings, startup, operation under normal, radio silence and unusual conditions, and shutdown. Chapter 4 provides general theory of operation and a block diagram of the AN/GRC-213 and its interfaces. Also included are detailed theory and a functional schematic of each AN/GRC-213 unit. Chapter 5 contains operator maintenance instructions, including preventive maintenance and cleaning and corrosion control procedures. Chapter 6 provides organizational maintenance instructions which include troubleshooting and replacement of units and accessories. Chapter 7 provides preparation for storage and shipment instructions. Appendix A contains information on all referenced and related technical manuals. Appendix B contains the AN/GRC-213 maintenance allocation chart. Appendix C provides lists with illustrations of the components of the end item and basic issue items. Appendix D contains a list of all items that are additional authorizations. Appendix E provides information on all expendable/durable supplies and materials.

#### **1-2. Maintenance Forms, Records, and Reports.**

*a. Report of Maintenance and Unsatisfactory Equipment.* Department of the Army forms and procedures used for equipment maintenance will be those prescribed by DA Pam 738-750 as contained in Maintenance Management Update.

*b. Reporting of Item and Packaging Deficiencies.* Fill out and forward SF 364 (Report of Discrepancy (ROD)) as prescribed in AR 735-11-2/DLAR 4140.55/SECNAVINST 4355.18/AFR 400-54/MCO 4430.3J.

*c. Transportation Discrepancy Report (TDR) (SF 361).* Fill out and forward Transportation Discrepancy Report (TDR) (SF 361) as prescribed in AR 55-38/NAVSUPINST 4610.33C/AFR 75-18/MCO P4610.19D/DLAR 4500.15.

**1-3. Consolidated Index of Army Publications and Blank Forms.** Refer to the latest issue of DA Pam 25-30 to determine whether there are new editions, changes, or additional publications pertaining to the equipment.

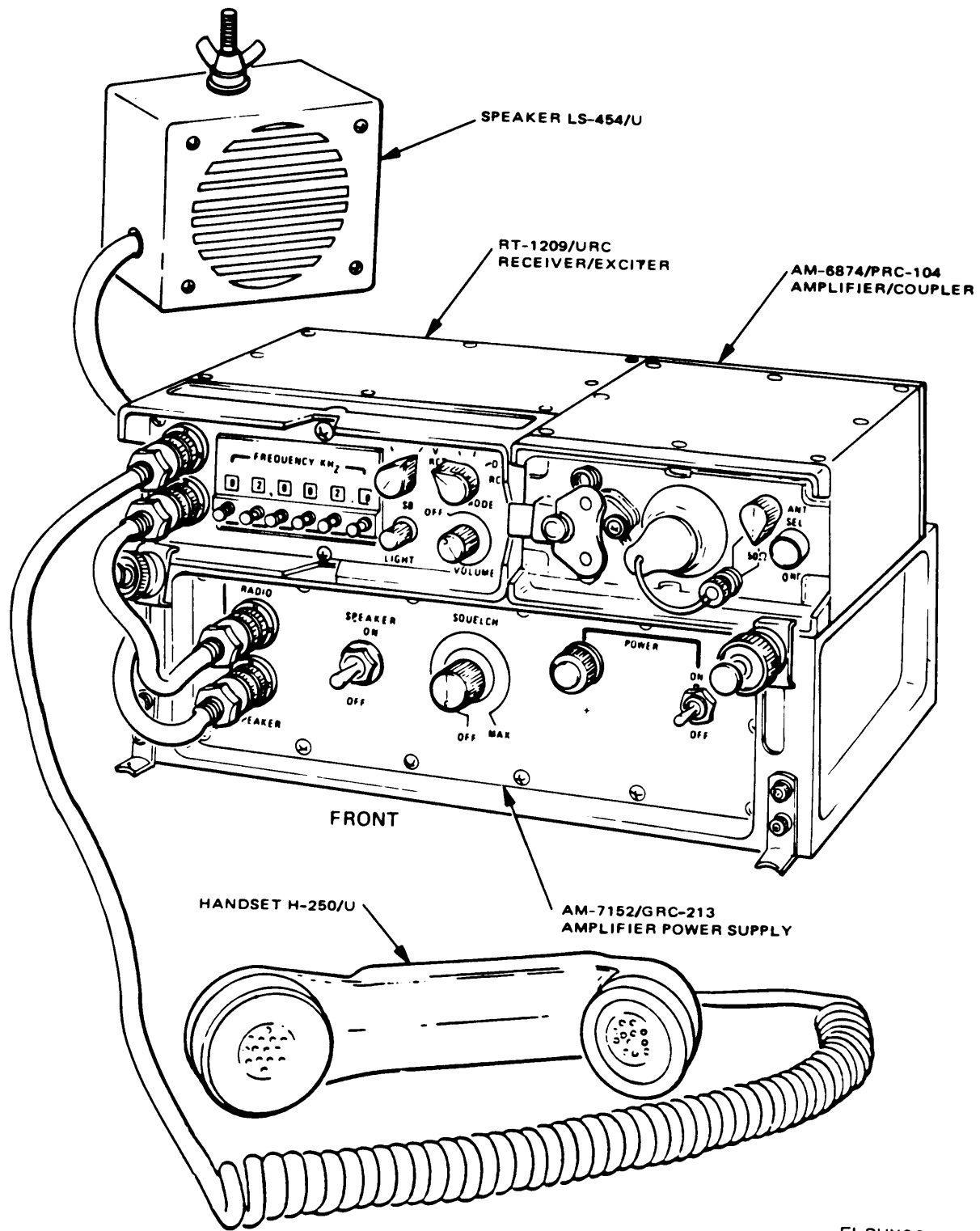

EL9WX001

Figure 1-1. Radio Set AN/GRC-213 (Sheet 1 of 2)



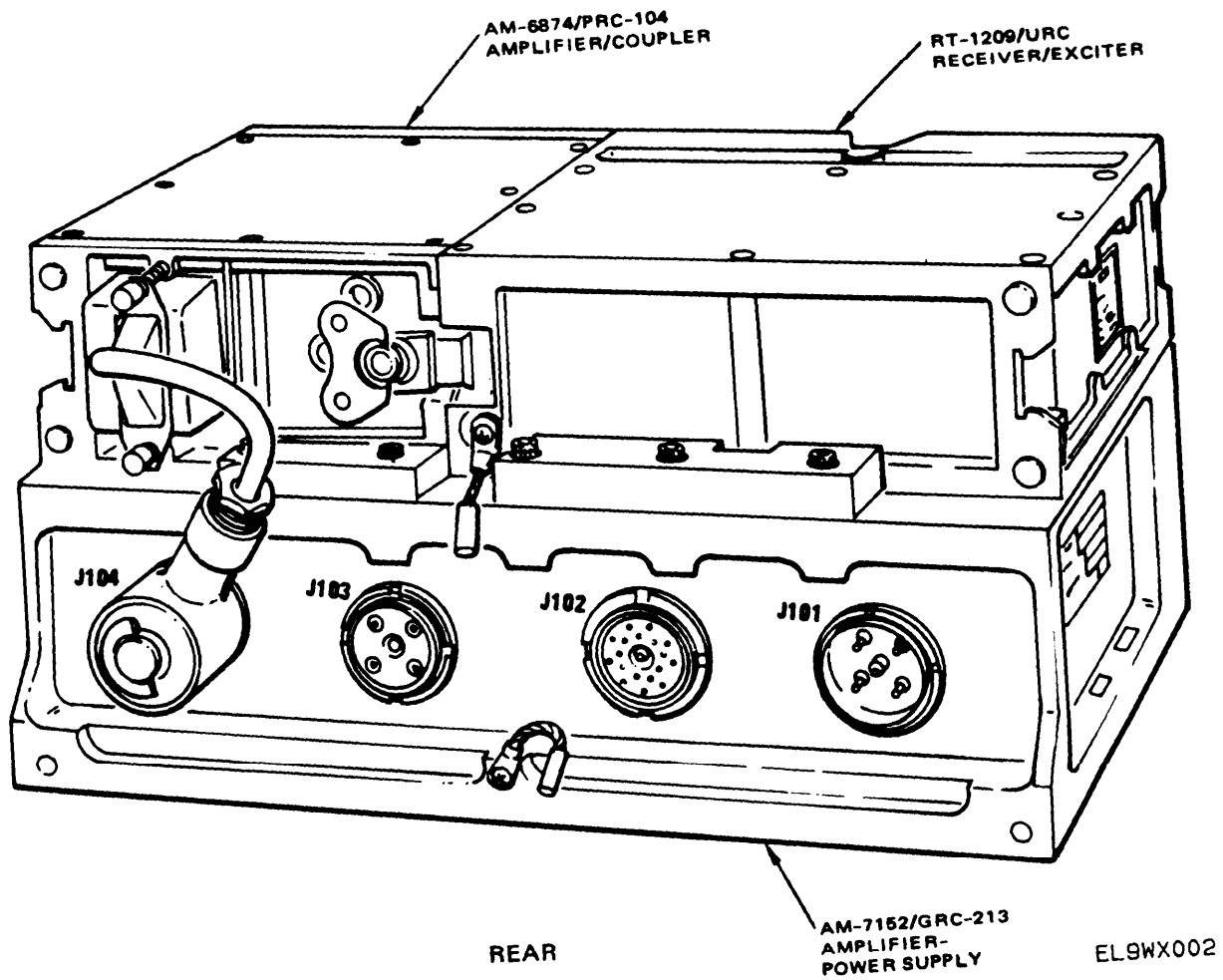

Figure 1-1. Radio Set AN/GRC-213 (Sheet 2 of 2).

**1-4. Hand Receipt (-HR) and Related Technical Manuals.** This paragraph describes the purpose and instructions for ordering hand receipt manuals. Information about technical manuals related to the AN/GRC-213 is also provided.

*a. Hand Receipt.* This manual has a companion document with a TM number followed by “-HR” (which stands for hand receipt). The TM 11-5820-923-10-HR consists of preprinted hand receipts (DA form 2062) that list end-related equipment (i.e., COEI, BII, and AAL) you must account for. As an aid to property accountability, additional -HR manuals may be requisitioned from the following source in accordance with procedures in Chapter 12, AR 25-30 and DA Pam 310-10.

Commander  
Baltimore AG Publications Center  
2800 Eastern Blvd.  
Baltimore, Md 21220

*b. Related Technical Manuals.* For a list of current publications applicable to the AN/GRC-213, refer to appendix A of this manual, References.

**1-5. Destruction of Army Electronics Materiel to Prevent Enemy Use.** Destruction of Army electronics materiel to prevent enemy use shall be in accordance with TM 750-244-2.

**1-6. Administrative Storage.** Administrative storage of equipment issued to and used by Army activities will have preventive maintenance performed in accordance with Operator Preventive Maintenance Checks and Services, Chapter 5, Section I, before storing. When removing the equipment from administrative storage, the preventive maintenance procedures should be performed to assure operational readiness. Disassembly and packaging of equipment for shipment or limited storage are covered in Chapter 7, Preparation for Storage or shipment.

**1-7. Reporting Equipment Improvement Recommendations (EIR).** If your AN/GRC-213 needs improvement, let us know. send us an EIR. You, the user, are the only one who can tell us what you don't like about your equipment. Let us know why you don't like the design or performance. Put it on an SF 368 (Product Quality Deficiency Report). Mail it to Commander, US Army Communications-Electronics Command and Fort Monmouth, ATTN: AMSEL-PA-MA-D, Fort Monmouth, New Jersey 07703-5000. We'll send you a reply.

## Section II. EQUIPMENT DESCRIPTION

**1-8. Purpose and Function.** The AN/GRC-213 is an hf low-power transceiver designed for use on wheeled or tracked vehicles. It has the capability of tuning 280,000 different frequencies within the 2– to 29.9999–MHz range. An internal antenna tuner automatically tunes the radio to match any of the three supplied antennas within the operating frequency range. The AN/GRC-213 is made up of Radio Set AN/PRC-104A, Amplifier-Power Supply AM-7152/GRC-213, interconnecting cables, and Speaker LS-454. The AN/PRC-104A can also be used separate from the vehicle as a manpack radio set if desired (TM 11-5820-919-12).

*a. Radio Set AN/PRC-104A.* Refer to TM 11-5820-919-12 for purpose and function of AN/PRC-104A.

*b. Amplifier-Power Supply AM-7752/GRC-273.* The amplifier-power supply, together with interconnecting cables, provides interface and isolation between the AN/PRC-104A, Speaker LS-454, and the Vehicle Intercommunicate ion System AN/VIC-1(V). The amplifier-power supply receives input power from the vehicle power source through an electrical power cable assembly. The amplifier-power supply fully conditions and filters the power to protect the AN/PRC-104A from overvoltage, noise spike transients, radio-frequency interference (rfi), and reverse polarity. The conditioned and filtered power is sent to the amplifier/coupler through another electrical power cable assembly. An audio amplifier with squelch circuitry is provided in the amplifier-power supply for driving an LS-454 external loudspeaker with one watt of audio power. The amplifier-power supply can interface with the AN/VIC-1(V) to provide a remote handset operation capability. It can also interface with the AN/VIC-1(V) and a VHF FM radio set in the vehicle to provide retransmission capabilities. (Refer to para 1-8, capabilities and Features.)

**1-9. Capabilities and Features.** The AN/GRC-213 is an hf radio set that provides reliable long-range communication for wheeled or tracked military vehicles. The AN/GRC-213 incorporates the AN/PRC-104A manpack radio (less battery pack) with an amplifier-power supply and loudspeaker to produce a vehicular system. The AN/PRC-104A can also be used with a battery pack for manpack operation. For the detailed capabilities and features of the AN/PRC-104A, refer to the equipment description paragraph in TM 11-5820-919-12. The amplifier-power supply conditions and filters the vehicular power source for the radio set, in addition to amplifying and squelching the audio output to drive the external loudspeaker.

The AN/GRC-213 is easy to install and remove because of quick-release fasteners and connectors. The AN/GRC-213 controls are easy to operate even if the operator wears gloves. Blackout operation is possible because audible indicators are used rather than lighted meters or indicators. These audible indicators provide warning of low vehicular power, transmitter failure, or antenna tuning fault. The watertight AN/GRC-213 maintains frequency stability over the operational temperature range of -46° to +71°C.

Pushbutton frequency selection provides 280,000 channels from 2 to 29.9999 MHz in 100-Hz increments with selectable voice/data/cw modes in both upper or lower sideband operation. At any operating frequency within this range, the radio set will automatically tune to match the antenna used.

In some vehicles, equipment is provided for the amplifier-power supply to interface with the AN/VIC-1(V) and a VHF FM radio set (in the vehicle) for automatic retransmission. The automatic retransmission capability allows any remote high frequency single sideband (HF SSB) radio set(s) to transmit signals to, and receive signals from, any remote VHF FM radio set(s) via the AN/GRC-213, AN/VIC-1(V), and VHF FM radio set. This is accomplished by receiving an HF SSB signal from a remote HF SS6 radio set and converting it to a VHF FM signal before retransmitting. Likewise, a VHF FM signal can be received from a remote VHF FM radio set, converted to an HF SSB signal, and then retransmitted. Because hf generally allows communications over greater distances, this feature allows communications between a local network of VHF FM radio sets and a distant HF SSB radio set at a command communications center.

The AN/VIC-1(V) can also be used to allow remote stations (handsets) within the vehicle to transmit and receive signals through the AN/GRC-213.

**1-10. Difference Between Models.** Only one model of the AN/GRC-213 is available. There is no difference between AN/GRC-213 radio sets.

**1-11. Equipment Specifications.** Equipment specifications for the AN/GRC-213 are listed in table 1-1.

Table 1-1. Equipment Specifications

Specification	Description
AN/GRC-213	
Frequency Range	2 to 29.9999 MHz in 0.0001 -MHZ (100-HZ) increments (280,000 possible frequency settings)
Frequency Accuracy	+1 ppm for -51°F (46°C) to +160°F (+71°C) (+2 to 30 Hz of setting) from 2 to 30 MHz, respectively
Operating Modes	<ul style="list-style-type: none"> <li>- Single sideband (selectable USB or LSB)</li> <li>- Voice/cw (Morse or burst cw at 300 wpm)</li> <li>- Data (FSK or DPSK up to 2400 bps) compatible with 75 baud military teletype</li> <li>- Receive only (inhibits transmit operation)</li> </ul>
Antenna Tuning	Automatic to 1.5:1 vswr (3 seconds tuning time, typical)

Table 1-1. Equipment Specifications (Continued)

Specification	Description
Antennas	Whip Slant wire Dipole NVIS
Input Voltage	24 to 32 V dc, 26,5 V dc nominal
Input Power	200 W maximum when operated with 26.5 V dc nominal input voltage. Meets applicable provisions of MIL-STD-1275
Operating Temperature Range	-51°F (-46°C) to +160°F (+71°C)
Environmental	Meets applicable provisions of MIL-STD-810B
Mean Time Between Failure (MTBF)	1600 hours (demonstrated per MIL-STD-785)
Mean Time to Repair (MTTR)	15 minutes (module replacement)
Dimensions	12.5 x 6.12 x 8.63 in. (31.75 x 15.55 x 21.91 cm) W x H x D
Weight	21 pounds (9.51 kg), excluding accessories and installation kit
AN/PRC-104A RECEIVER (PART OF RECEIVER/EXCITER)	
Sensitivity (SSB, CW, FSK)	0.7 $\mu$ V for 10 dB SINAD (-110 dBm voice, -70 dBm data)
Selectivity (SSB, CW, FSK)	2.5-kHz bandwidth at -3 dB 6-kHz bandwidth at -60 dB
Image Rejection	70 dB
IF Rejection	60 dB
Audio Output	25 mW into 500 ohms (nominal)
Audio Distortion	5% at 5 mW, 350 to 3000 Hz
Desensitization (signal to degrade SINAD 3 dB)	$\pm$ 2.5% to -29 dBm $\pm$ 10% to -15 dBm $\pm$ 50% to +17 dBm
Protection	20 W input to antenna

Table 1-1. Equipment Specifications (Continued)

Specification	Description
<b>AN/PRC-104A TRANSMITTER (PART OF RECEIVER/EXCITER)</b>	
RF Output Power	0.3 W (PEP) for receiver/exciter, 20 W (PEP or average) with amplifier/coupler
RF Output Impedance	50 ohms, unbalanced. Output protected to infinite vswr due to antenna short or open
Intermodulation Distortion (IMD)	-25 dB (two equal tones at rated output power)
Harmonic Radiation	-50 dB
Carrier Suppression	-42 dB
Unwanted Sideband Suppression	-45 dB
All Other Spurious	-45 to -60 dB
Duty Cycle	1 minute continuous keydown, 9:1 receive/transmit ratio
Sidetone	All modes
Audio Compression	+20 dB above nominal
Audio Input Impedance and Level	150 ohms, -56 dBm (voice) or 6 mV rms 600 ohms, 0 dBm (data) or 0.77 V rms
<b>AMPLIFIER-POWER SUPPLY</b>	
Power Protection	Reverse polarity and short circuit
Conditioned Current	5.5 amps maximum
Auxiliary Current	10 amps maximum
Conditioned Voltage	22 V dc minimum with 26.5 V dc nominal input
Audio Input Power	2 mW minimum from RT-1209/URC into 500 ohms
Audio Output Power	1 W (300 to 3000 Hz) into 600 ohms, harmonic distortion 12% maximum
Unmuted Audio Output Power	80 mW into 600 ohms
Monitor Amplifier Audio Output Power	0.16 V rms into 150 ohms

Table I-I. Equipment Specifications (Continued)

Specification	Description
<p>Audio Frequency Response</p> <p>Audio Output Muting (Squelched)</p> <p>Squelch</p> <p>Sensitivity (a measure of the ability of the squelch circuit to distinguish between a signal and a no-signal condition)</p> <p>Attack Time (the amount of time required for a signal to be present before the squelch circuit will respond to the signal)</p> <p>Release Time (the amount of time required for a signal to be absent before the squelch circuit will respond to the absence of the signal)</p> <p>Hysteresis (after a signal has removed squelch, the amount in reduction in signal strength that is allowed and-will not cause squelching to occur)</p>	<p>300 to 3000 Hz <math>\pm</math>3 dB (1 W)</p> <p>30 dB minimum</p> <p>Adjustable for 10 to 20 dB signal-to-noise ratio</p> <p>35 ms maximum</p> <p>300 ms minimum to 3 sec</p> <p>After unsquelching, the unsquelched condition is maintained for up to 2 dB reduction in signal</p>

**Section III. EQUIPMENT AND TOOLS LISTS**

**1-12. Equipment Supplied.** The AN/GRC-213 equipment that is supplied is listed in table 1-2 by official nomenclature and national stock number. This table also lists the common names, dimensions, and weights of the equipment supplied. Common names, rather than official nomenclature, are generally used for equipment throughout this manual. Refer to this table for official nomenclature.

**1-13. Equipment Required But Not Supplied.** Table 1-3 lists the equipment required for use with the AN/GRC-213 but not supplied, by official nomenclature. This table also lists the common names and purpose of the equipment required but not supplied. Common names, rather than official nomenclature, are generally used for equipment throughout this manual. Refer to this table for official nomenclature.

**1-14. Special Tools and Test Equipment.** The tools and test equipment required to perform organizational maintenance of the AN/GRC-213 are listed in table 1-4. Equivalent test equipment may be used.

NOTE

Use only test equipment that is properly calibrated. Failure to do so may result in erroneous and misleading performance or fault indications.

Table 1-2. Equipment Supplied

Official Nomenclature	National Stock Number	Common Name	Overall Dimensions	Weight
Radio Set AN/GRC-213	5820-01-128-3935	AN/GRC 213	...	...
Amplifier-Power Supply AM-7152/ GRC-213	5820-01-127-5855	Amplifier power supply	12.50 in. (31.75 cm) wide 3.50 in. (8.89 cm) high 8.63 in. (21.91 cm) deep	11.0 lb (4.99 kg)
Speaker LS-454/U	5965-00-876-2375	Loudspeaker	4.91 in. (12.47 cm) wide 7.03 in. (17.86 cm) high 3.19 in. (8.10 cm) deep	4.0 lb (1.81 kg)
Cable Assembly, Power Conditioner	5995-01-219-9516	AN/PRc-104A power cable	7.38 in. (18.75 cm) long	...



Table 1-2. Equipment Supplied (Continued)

Official Nomenclature	National Stock Number	Common Name	Overall Dimensions	Weight
Cable Assembly, Audio	<b>5995-01-219-9441</b>	Audio cable	11.0 in. (27.94 cm) long	...
Cable Assembly, Radio Frequency	<b>5995-01-213-5188</b>	RF cable	2.50 in. (6.35 cm) long	...
Radio Set AN/PRC-104A	5820-00-1141-7953	AN/PRC-104A	...	...
Case, Radio Set CY-8291/PRC-104		Transit case	22.0 in. (55.88 cm) wide 15.25 in. (38.74 cm) high 14.5 in. (36.83 cm) deep	28.0 lb (12.70 kg)
Receiver/Transmitter RT-1209/URC	5820-01-069-2368	Receiver/exciter	7.25 in. (18.42 cm) wide 2.62 in. (6.66 cm) high 7.25 in. (18.42 cm) deep	5.90 lb (2.68 kg)
Amplifier, Radio Frequency AM/6874/PRC-104	5820-01-065-5044	Amplifier/coupler	5.25 in. (13.34 cm) wide 2.62 in. (6.66 cm) high 7.25 in. (18.42 cm) deep	4.10 lb (1.86 kg)
<b>Antenna (NVIS) AS-2259/GR</b>	5985-00-106-6130	NVIS antenna	...	23.5 lb (10.66 kg)
Mast Assembly, Top	...	Top mast assembly	...	...
Sections, Mast	...	Mast sections	22 in. (55.88 cm) long	...
Cable Assemblies, Radio Frequency	...	NVIS rf cables	...	...
Case, Carrying	...	Antenna pack	...	...

Table 1-2. Equipment Supplied (Continued)

Official Nomenclature	National Stock Number	Common Name	Overall Dimensions	Weight
<b>Adapter (AN/GRA-50) UG-349/U</b>	5935-00-204-5118	Dipole antenna adapter	...	...
Antenna Group AN/GRA-50	5985-00-892-0758	Dipole antenna	...	11.75 lb (5.33 kg)
Cable Assembly, Radio Frequency CG-678/LJ	...	Dipole rf cable	75 ft, 3 in. (22.94 m) long	...
Insulator IL-4/GRA-4	...	Insulator	...	...
Reeling Machine, Cable, Hand RC-432-G	...	Reel assembly	...	...
Wire Assembly, Antenna CX-7303/G	...	Antenna wire	160 ft (48.77 m) long	...
Halyard MX-2706/G	...	Halyard	75 ft (22.86 m) long	...
Tape, Measuring	...	Tape measure	156 ft (47.55 m) long	...
Bag BG-175	...	Dipole carrying bag	...	...
Handset H-250/U	5965-00-043-3463	Handset	...	0.8 lb (0.36 kg)
Key Telegraph KY -872/ PRC-104	5805-01-067-5388	CW key	...	...
Card Instruction		Instruction card	...	...
*Case, Battery CY-7875/PRC-104	6135-01-080-2886	Battery case	12.5 in. (31.75 cm) wide 6.5 in. (16.51 cm) high 3.25 in. (8.26 cm) deep	...

Table 1-2. Equipment Supplied (Continued)

Official Nomenclature	National Stock Number	Common Name	Overall Dimensions	Weight
*Cable Assembly Power, Electrical CX-13030/PRC-104	5820-01-065-8131	Battery extender cable	48 in. (121.92 cm) long	...
*Cable Assembly, Power, Electrical	...	Battery charger cable	...	...
*Cable Assembly, Radio Frequency CG-3815/U	...	NVIS rf cable	24 in. (60.96 cm) long	...
*Antenna, Spring Section AB-129/PR	5820-00-234-4127	Shock mount	...	...
*Antenna AT-271(A)/PRC	5985-00-646-2365	Manpack whip antenna	10 ft (3.048 m) long	0.7 lb (0.32 kg)
*Base, Antenna (NVIS)	...	Antenna base	...	...
*Frame, Pack	8465-00-001-6475	Pack frame	...	...
*Field Pack	8465-01-019-9102	Field pack	...	...
*Shelf, Cargo Support	8465-00-001-6476	Cargo shelf	...	...
*Strap, Webbing	8465-00-001-6477	Webbing strap	...	...

\*Equipment used for manpack operation only, TM 11-5820-919-12.

Table 1-3. Equipment Required But Not Supplied

Nomenclature	Common Name	Purpose
AN/GRC-213 Electrical Equipment Installation Kit	Installation Kit	Mounting the AN/GRC-213 and providing antenna connection.
NOTE		
AN/VIC-1(V) only required for use with M577A1 and M113A1 vehicles.		
Intercommunication Set AN/VIC-1(V)	AN/VIC-1(V)	Provides communication link between HF and VHF FM radios.
Radio Set AN/GRC-213	AN/GRC-213	Provides external rf signals for fault isolation procedures.

Table 1-4. Organizational Maintenance Special Tools and Test Equipment

Name	Designation	Item Parameters	National Stock Number
Tool Kit, Electronic Equipment	TK-101/G	...	5180-00-064-5178
Charger, Battery	PP-6241/U	400 ma max at +31 V, 100 ma max at +32 V	6130-00-106-6445
Multi meter, Digital	AN/PSM-45	2 to 30 MHz, 1 to 3 V ac, 24 to 32 V dc	6625-01-139-2512
Test Set, Radio Frequency Power	AN/USM-298	2 to 30 MHz, 12.5 to 31 W	6625-00-880-5119
Dummy Load, Electrical	8085	2 to 30 MHz, 5.5 to 31 W	5985-00-477-8165
Detecting Element	50H	2 to 30 MHz, 5.5 to 31 W	6625-00-945-6092

## CHAPTER 2 PREPARATION FOR USE AND INSTALLATION INSTRUCTIONS

### Section I. PREPARATION FOR USE

**2-1. Unpacking.** Unpacking instructions for the AN/GRC-213 are contained in the following subparagraphs.

a. AN/PRC-704A. The AN/PRC-104A is contained, transported, and stored in a transit case. The transit case should normally be kept closed. To unpack the equipment, unfasten the four latches and remove the transit case cover. Each of the individual pieces of equipment fits in a molded space in the case. Check that the equipment is completely referring to the equipment supplied list in TM 11-5820-919-12. Inspect the equipment for any damage incurred during shipment. The receiver/exciter, amplifier/coupler, cw key, NVIS antenna base, dipole adapter, and handset are the components normally used for the AN/GRC-213. Other equipment supplied in the transit case is for manpack operation (TM 11-5820-919-12).

**WARNING**

Do not store lithium battery BA-5590/U in transit case longer than 30 days. After 30 days, the battery will discharge, overheat, and vent hazardous sulfur dioxide fumes.

The manpack equipment should be stored in the transit case. The lithium manpack batteries shouldn't be stored in the transit case longer than 30 days. If lithium batteries have been stored for 30 days, the local property disposal office must be recontacted for disposal instructions because the material being disposed of is classified as hazardous waste.

b. Amplifier-Power Supply and Auxiliary Equipment. The amplifier-power supply and auxiliary equipment for the AN/GRC-213 are shipped in standard packages sufficient to provide adequate protection from shock and freight damage. Verify that all items listed in packing lists are present. Inspect the equipment for any damage incurred during shipment.

**2-2. Mounting.** Instructions for mounting the AN/GRC-213 on the installation kit and installing the accessories are contained in the following subparagraphs. For manpack operation, refer to TM 11-5820-919-12.

a. AN/GRC-273. To mount the AN/GRC-213 main components on the installation kit, proceed as follows:

- (1) Verify that the installation kit has been properly mounted in the vehicle as outlined in Installation Instructions paragraph in TM 11-2300-476-14&P. Mount installation kit, if necessary.
- (2) Attach amplifier/coupler and receiver/exciter units together, using two latches (fig. 2-1).

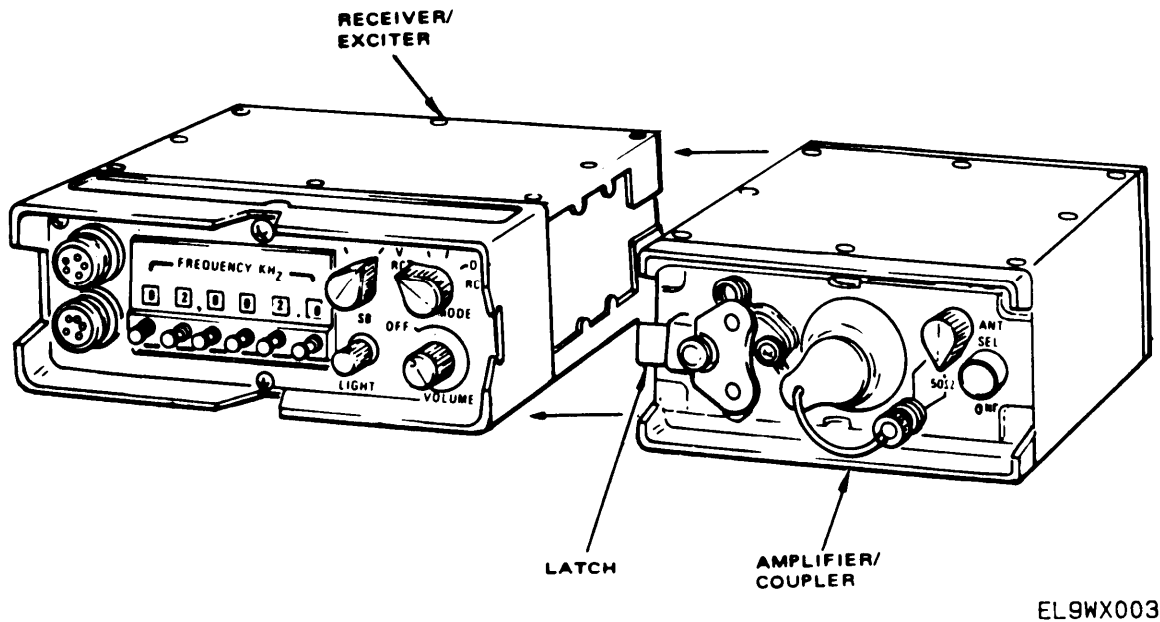
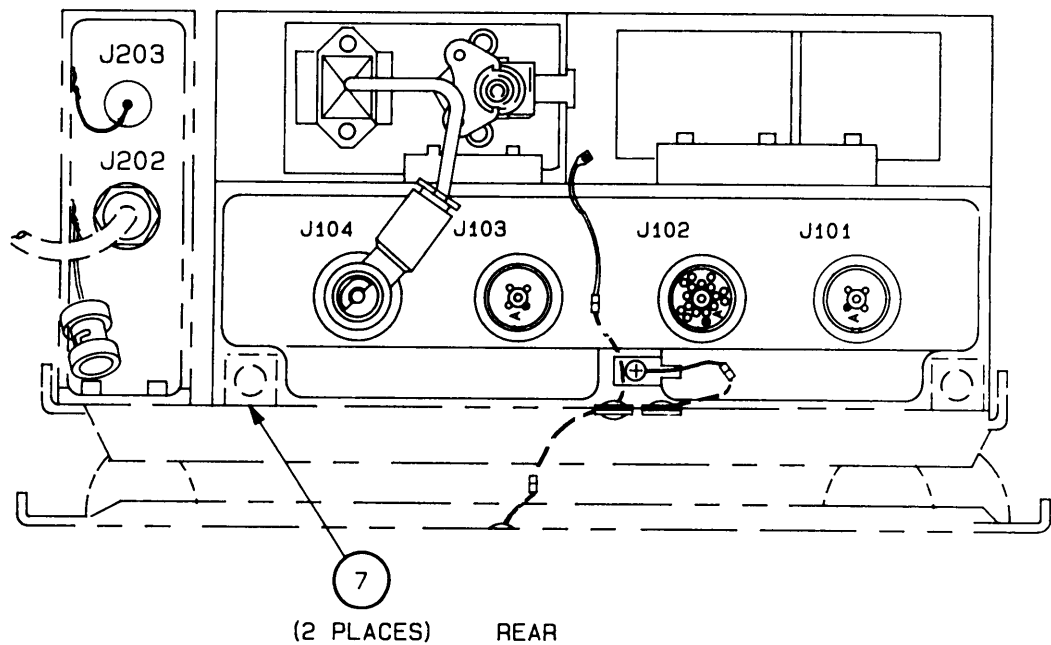
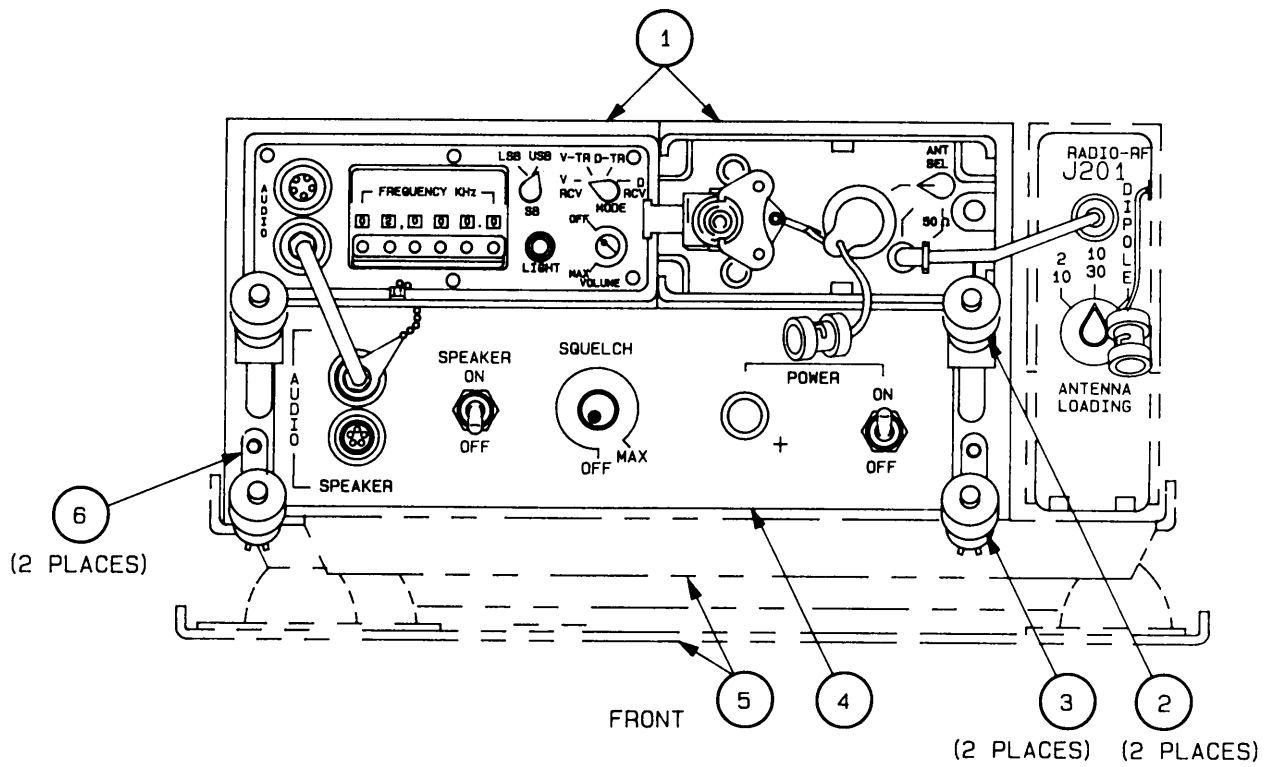

Figure 2-1. Latching of Receiver/Exciter and Amplifier/Coupler

- (3) Place latched receiver/exciter and amplifier/coupler (1, fig. 2-2) on top of amplifier-power supply (4, fig. 2-2).
- (4) Slide latched receiver/exciter and amplifier/coupler (1, fig. 2-2) toward rear of amplifier-power supply (4, fig. 2-2). Verify that receiver/exciter and amplifier/coupler fully engage retaining cleats on rear of amplifier-power supply. If necessary, push latched receiver/exciter and amplifier/coupler back until they fully engage retaining cleats.
- (5) Tighten two fasteners (2, fig. 2-2) overbooks, located on front of receiver/exciter and amplifier/coupler (1, fig. 2-2), until receiver/exciter and amplifier/coupler are securely attached to top of amplifier-power supply (4, fig. 2-2).
- (6) Slide amplifier-power supply (4, fig. 2-2), with latched receiver/exciter and amplifier/coupler on top, onto mounting base (5, fig. 2-2). Rear of amplifier-power supply will be toward rear of mounting base. Slide amplifier-power supply straight back until it is fully seated against guide pin assembly (7, fig. 2-2) located on rear of mounting base.
- (7) Tighten two fasteners (3, fig. 2-2) over two hooks (6, fig. 2-2) until amplifier-power supply, with latched receiver/exciter and amplifier/coupler, is securely attached to mounting base (5, fig. 2-2).
- (8) To mount the loudspeaker, refer to Installation Instructions paragraph in TM 11-2300-476-14&P.



EL9WX004

Figure 2-2. Mounting Diagram

b. *Antenna Installation.* Before installing antenna, select the type of antenna to be installed per paragraph 3–5, Operating Considerations. To install the whip antenna, refer to Installation Instructions paragraph in TM 11-2300-476-14&P. The installations of the Near Vertical incidence Skywave (NVIS) and dipole antennas are outlined in the following subparagraphs.

**WARNING**

Do not smoke or use flame near fuel or vehicle fuel system. Fire or explosion may occur, causing personal injury or DEATH.

(1) *NVIS antenna installation.* To erect the NVIS antenna, proceed as follows:

**WARNING**

Antenna installation area must be free of power lines. Antenna contact with power lines during installation may cause serious injury or even DEATH to operator.

NOTE

The NVIS antenna is fully tuned by the AN/GRC-213 only at frequencies between 2 and 12 MHz. It may be used at frequencies above 12 MHz, but may not work at all frequencies.

- (a) Determine installation area. An 84 by 84 ft area is required for NVIS installation.
- (b) Place antenna base on ground next to vehicle. Base must be located close enough to allow NVIS rf cable to connect between base and switching unit (part of installation kit).
- (c) Open antenna pack and remove top mast assembly (fig. 2-3A).
- (d) Install top mast assembly in antenna base on ground and uncoil antenna elements one at a time. Verify that the antenna elements are stretched along the direction in which they leave the top housing and are not shorted to each other or to the mast. If necessary, adjust direction of elements (fig. 2-3A).
- (e) Measure anchor positions, using metal sleeve cable markers as guides, and install anchors as shown in figure 2–3B. Leave slack in elements lying on ground.

NOTE

Dirty mast sections will reduce NVIS antenna performance.



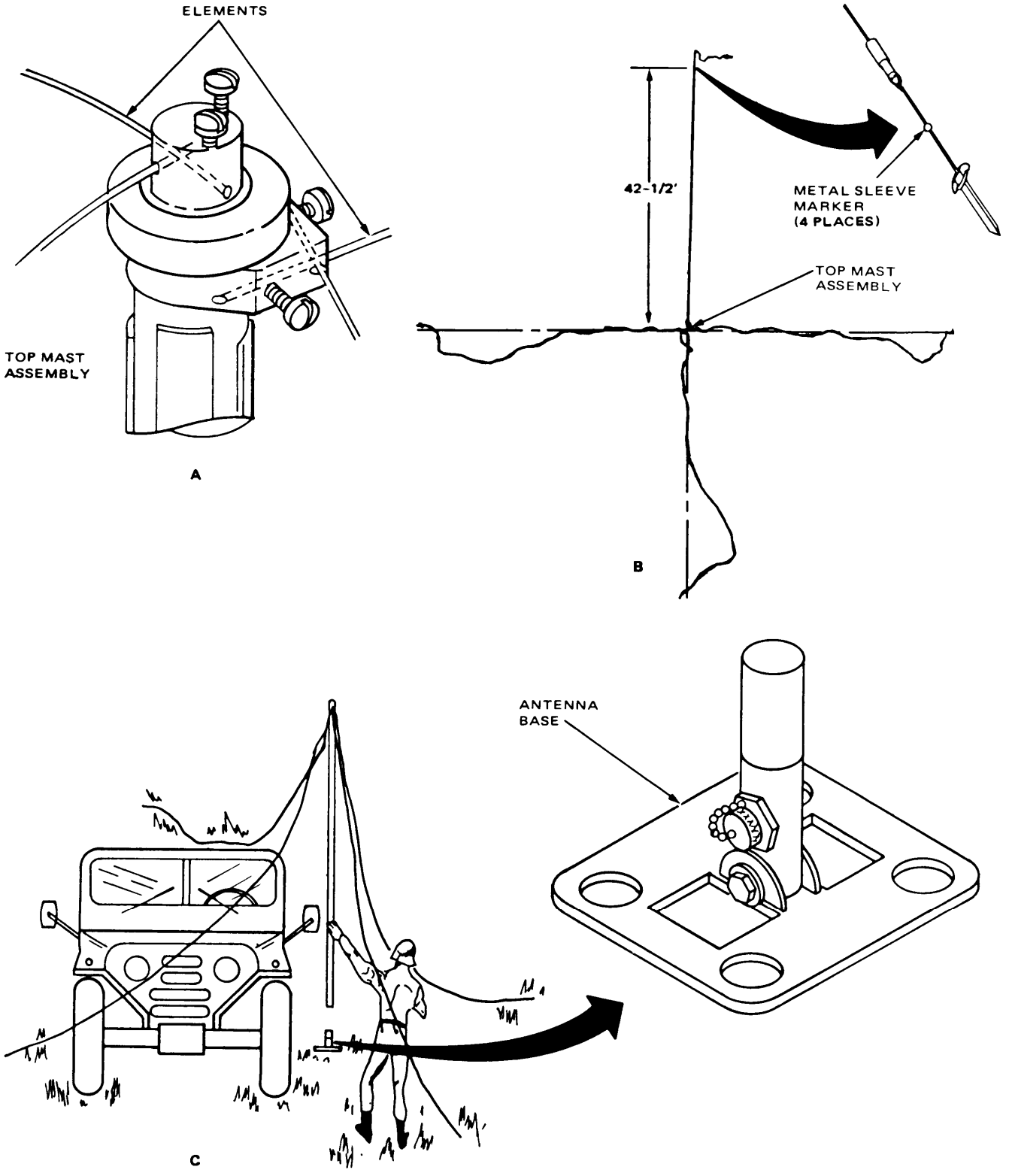

Figure 2-3. NVIS Antenna Installation

EL9WX005

- (f) Before connecting mast sections, wipe unpainted mating surfaces clean of mud or dirt to provide good electrical contact.
- (g) Assemble mast by raising top mast assembly and inserting each of the 7 22-inch mast sections one at a time. Insert bottom mast section in antenna base (fig. 2-3C).
- (h) Adjust tension on all elements until mast is vertical and straight. Elements need not be excessively taut.

(2) *Dipole Antenna Installation.* To erect a dipole antenna, proceed as follows (fig. 2-4 thru 2-10):

- (a) Connect antenna wire terminal hooks to thumb nuts on opposite ends of the insulator, (fig. 2-4).
- (b) Connect dipole cable to insulator as shown in figure 2-4.
- (c) Temporarily fasten insulator (fig. 2-4) to one of the desired supports (fig. 2-8 and 2-9) that will later be used to fasten each end of antenna.
- (d) Temporarily fasten free end of tape measure to center of insulator.
- (e) Unwind frequency tape measure to length corresponding to desired frequency using marks on back of tape. If the tape measure is not available, use table 2-1 to determine each antenna wire length; then pace off (one stride is approximately three feet) the indicated antenna length.
- (f) Unroll an equal amount of wire, of the length determined in the previous step, from each reel assembly as follows (fig. 2-5):
  - 1 Grasp reel assembly firmly in one hand and loosen thumb nut at center of reel and thumb nut on wire clamp on reel assembly.
  - 2 Move away from antenna insulator center slowly, keeping the wire taut at all times. Hold thumb on wire to prevent backlash (fig. 2-6).
  - 3 After unwinding required amount of wire, tighten thumb nut on wire clamp and then thumb nut at center of reel.
- (g) Unfasten tape measure (if used) from insulator.
- (h) Unfasten insulator from support and lay antenna wires out in a straight line.
- (i) Check overall length of two wires plus insulator and reel assemblies. This overall length should be twice the length indicated in step (e) by the tape measure or table 2-1. Adjust the antenna for exact overall length. Be certain to keep insulator centered.
- (j) Attach each reel assembly to halyard snaphook fastener (fig. 2-7).

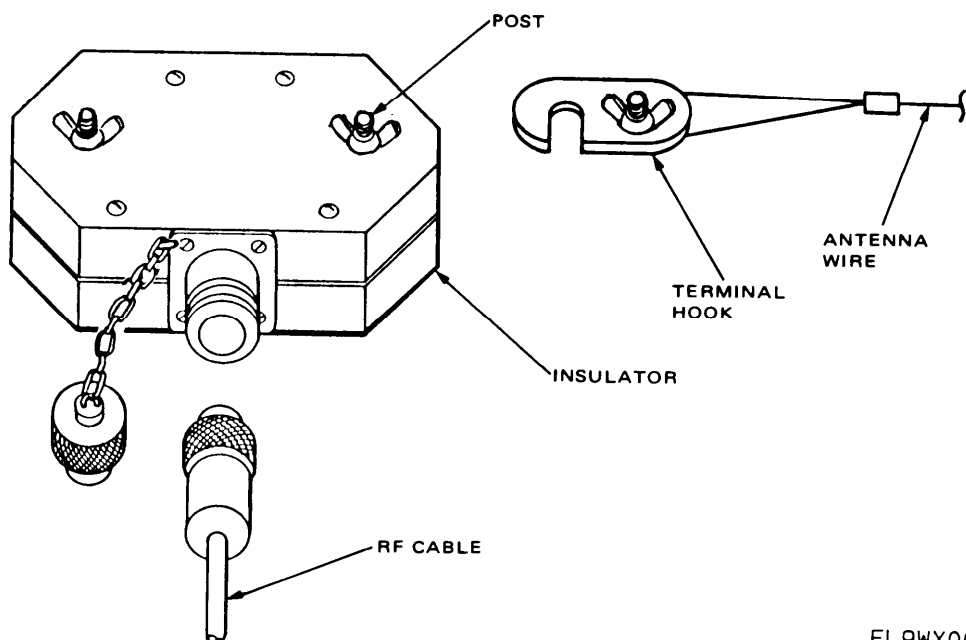

EL9WX006

Figure 2-4. Connecting RF Cable and Antenna Wire to Insulator

Table 2-1. Dipole Antenna Wire Length

Frequency (MHz)	Length of Each Antenna Wire (ft)	Frequency (MHz)	Length of Each Antenna Wire (ft)
2.00	117.00	5.40	43.33
2.05	114.14	5.60	41.78
2.10	111.42	5.80	40.35
2.15	108.83	6.00	39.00
2.20	106.36	6.20	37.74
2.25	104.00	6.40	36.56
2.30	101.73	6.60	35.45
2.35	99.57	6.80	34.41
2.40	97.50	7.00	33.42
2.45	95.51	7.50	31.20
2.50	93.60	8.00	29.25
2.55	91.76	8.50	27.52
2.60	90.00	9.00	26.00
2.65	88.30	9.50	24.63
2.70	86.66	10.00	23.40
2.75	85.09	10.50	22.29
2.80	83.57	11.00	21.27
2.85	82.10	12.00	19.51
2.90	80.68	13.00	18.00
2.95	79.32	14.00	16.71
3.00	78.00	15.00	15.60
3.10	75.48	16.00	14.62
3.20	73.12	17.00	13.76
3.30	70.90	18.00	13.00
3.40	68.82	19.00	12.31
3.50	66.85	20.00	11.70
3.60	65.00	21.00	11.14
3.70	63.24	22.00	10.64
3.80	61.57	23.00	10.17
3.90	60.00	24.00	9.75
4.00	58.50	25.00	9.36
4.20	55.71	26.00	9.00
4.40	53.18	27.00	8.67
4.60	50.86	28.00	8.36
4.80	48.75	29.00	8.07
5.00	46.80	29.99	7.80
5.20	45.00		

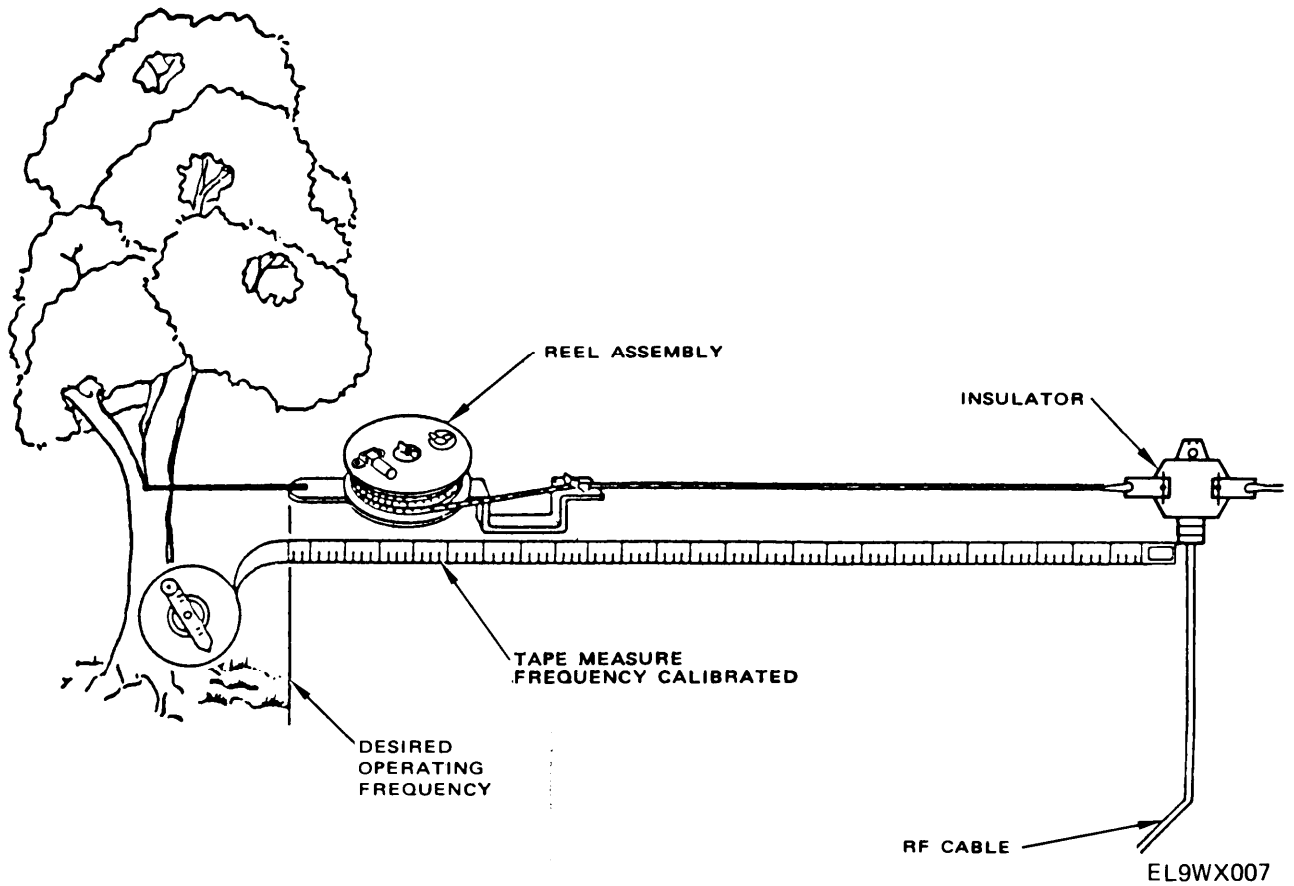

Figure 2-5. Use of Tape Measure to Determine Antenna Wire Length

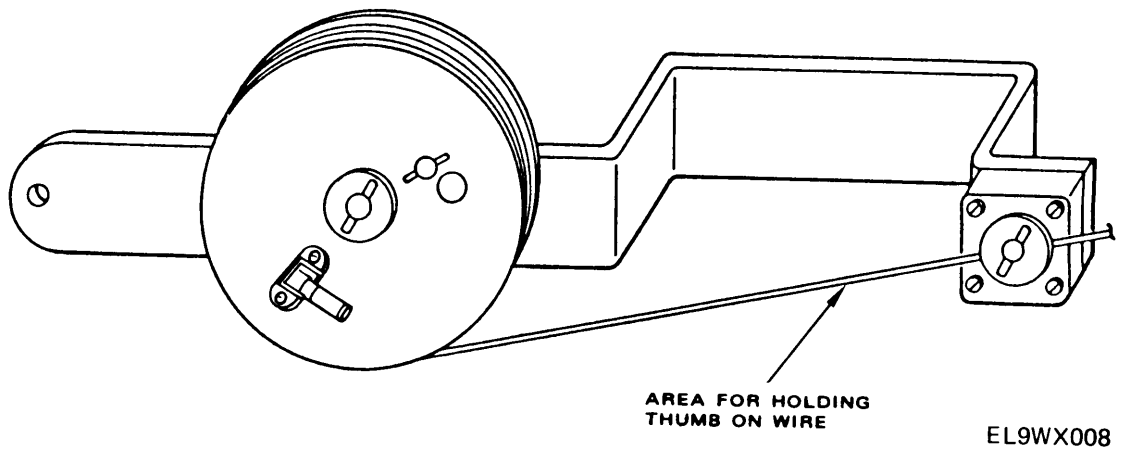

Figure 2-6. Unwinding Antenna Wire From Reel Assembly

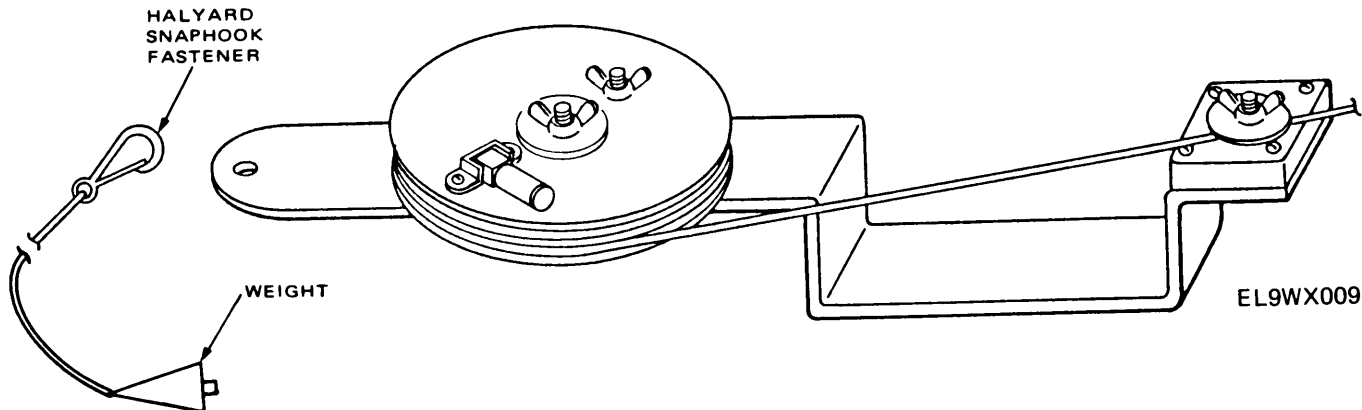

Figure 2-7. Attaching Halyard to Reel Assembly.

**CAUTION**

Allow antenna assembly to sag at least 6 inches when installing it in the following step to avoid damage to the antenna.

- (k) Tie the halyard to the best available supports (tree, fence post, vehicle, etc) at a height of 4 feet or higher. Try to select supports that will enable the height of the insulator at the center of the dipole to be  $\frac{1}{3}$  the antenna wire length. If two properly oriented supports are available, erect the two-support dipole antenna as illustrated in figure 2-8. If only one support is available, erect a sloping dipole or inverted V dipole as shown in figures 2-9 and 2-10.

**NOTE**

The dipole rf cable should be at right angles to the antenna wires for the first few feet from the connection at the insulator. Lay the dipole rf cable out as straight as possible; do not allow the cable to form loops.

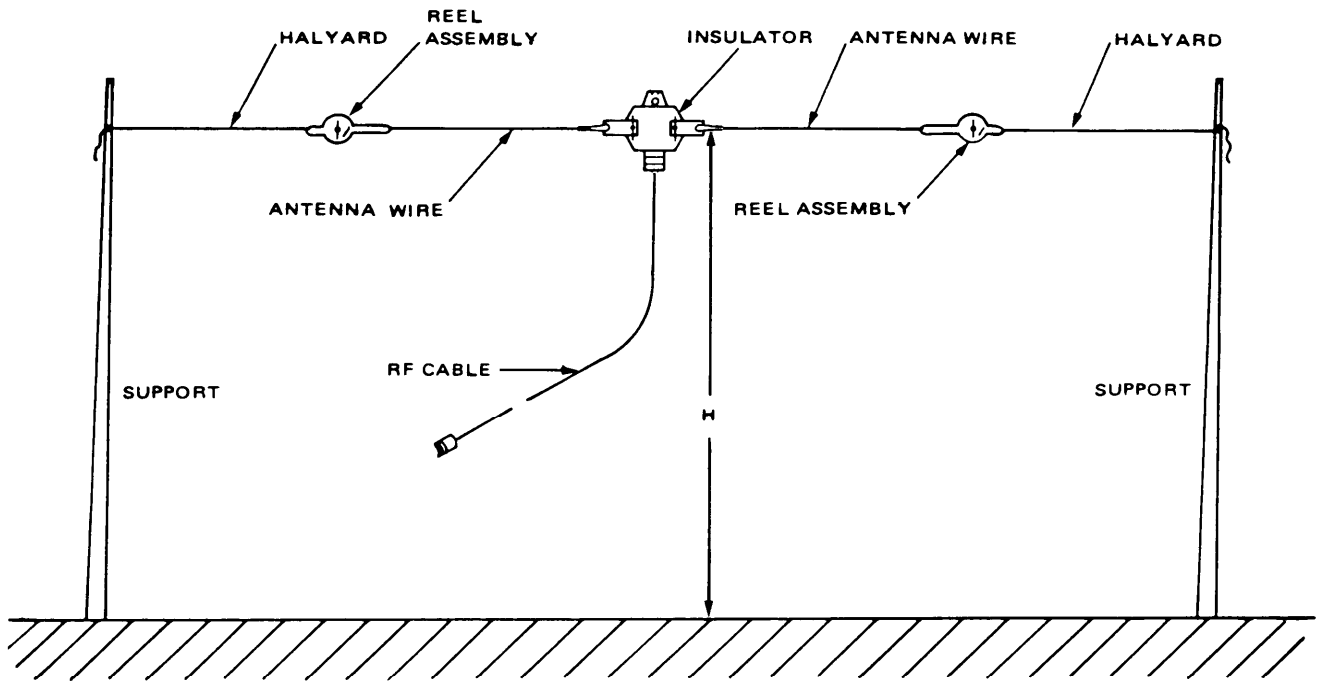

EL9WX010

Figure 2-8. Two-Support Dipole Antenna

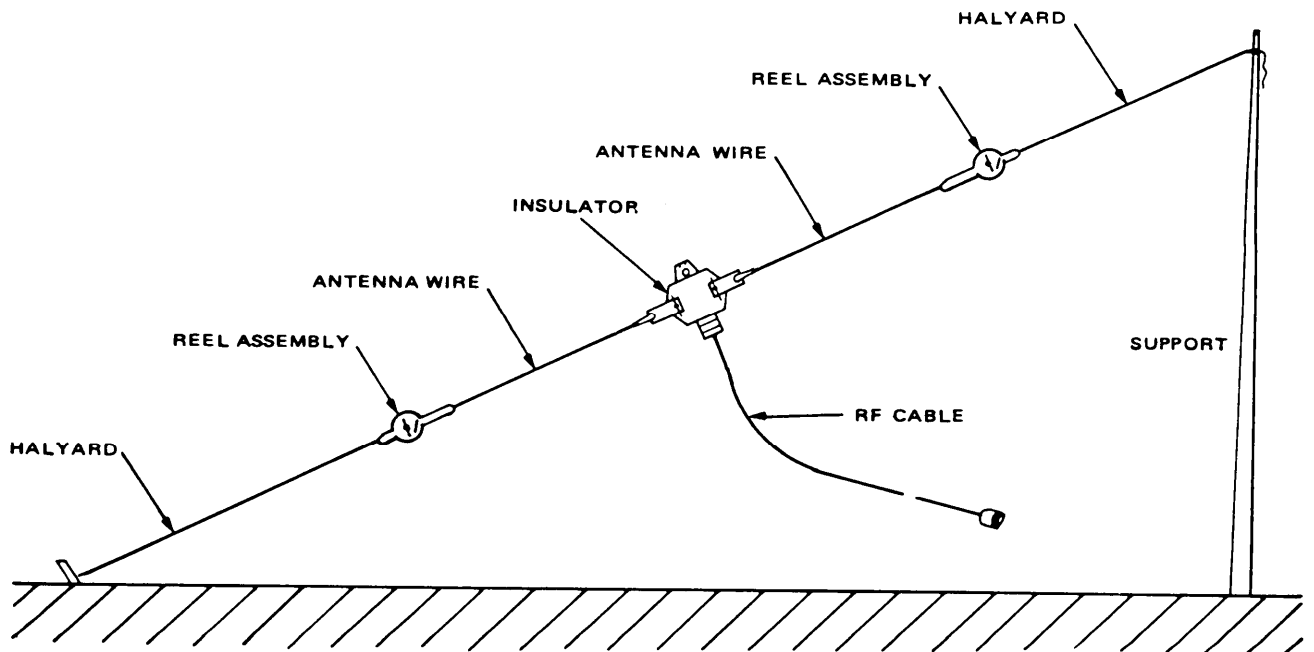

EL9WX011

Figure 2-9. Sloping Dipole Antenna

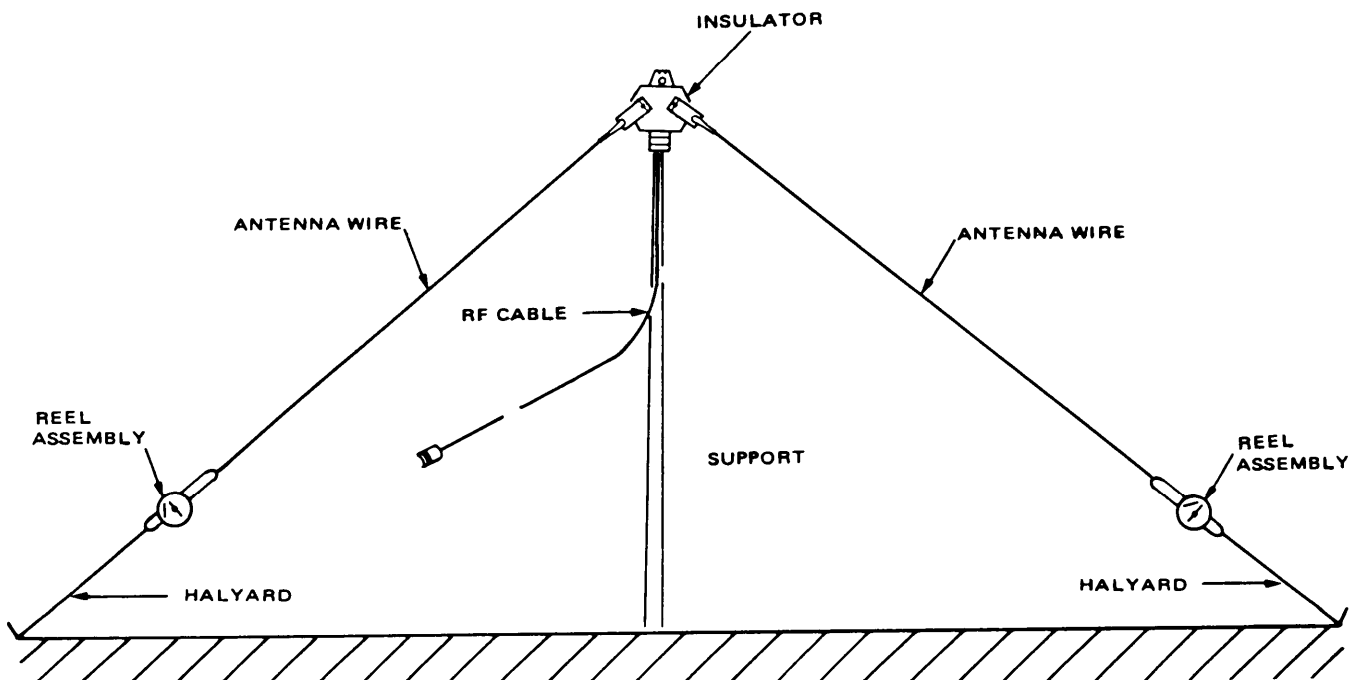

Figure 2-10. Inverted V Dipole Antenna



## Section II. CONNECTIONS

**2-3. Interconnections.** Cable interconnections between units and to the installation kit are described in the following procedures.

a. For vehicles M577A1, M882, and M113A1, set vehicle master power switch to off position.

**CAUTION**

Verify that POWER circuit breaker is set to OFF in following steps. otherwise, sparks may damage connector J104 (17, fig. 2-11) or power cable when connecting power cable to AN/GRC-213. Set POWER circuit breaker to OFF if necessary.

b. Verify that all connections to the installation kit have been completed as outlined in Installation Instructions paragraph of TM 11-2300-476-14&P. Make connections that have not been made, as necessary.

c. Remove bag from end of power cable (part of installation kit) and connect cable to connector J101 (16, fig. 2-11) on rear of amplifier-power supply.

d. Connect AN/PRC-104A power cable (12, fig. 2-11) from connector J104 (17, fig. 2-11), located on rear of amplifier-power supply, to AN/PRC-104A power input connector (11, fig. 2-11) on rear of amplifier/coupler (part of AN/PRC-104A).

**CAUTION**

Do not connect audio cable (9, fig. 2-11) to SPEAKER AUDIO connector (8, fig. 2-11) on amplifier-power supply. Otherwise, continuous transmission will result when the other end of the audio cable is connected to either AUDIO connector (1 or 2, fig. 2-11) of the receiver/exciter. This could damage the AN/PRC-104A.

NOTE

To prevent incorrect connection, verify that bead chain on audio cable is connected to the amplifier-power supply. Connect chain if necessary.

e. Connect audio cable (9, fig. 2-11), attached to front of amplifier-power supply by a short chain, to RADIO AUDIO connector (7, fig. 2-11) located on front of amplifier-power supply. Connect other end of audio cable to lower AUDIO connector (1, fig. 2-11) on front of receiver/exciter.

f. Connect rf cable (4, fig. 2-11) from BNC connector (3, fig. 2-11) on amplifier/coupler to BNC RADIO-RF connector J201 (5, fig. 2-11) on switching unit (part of installation kit).

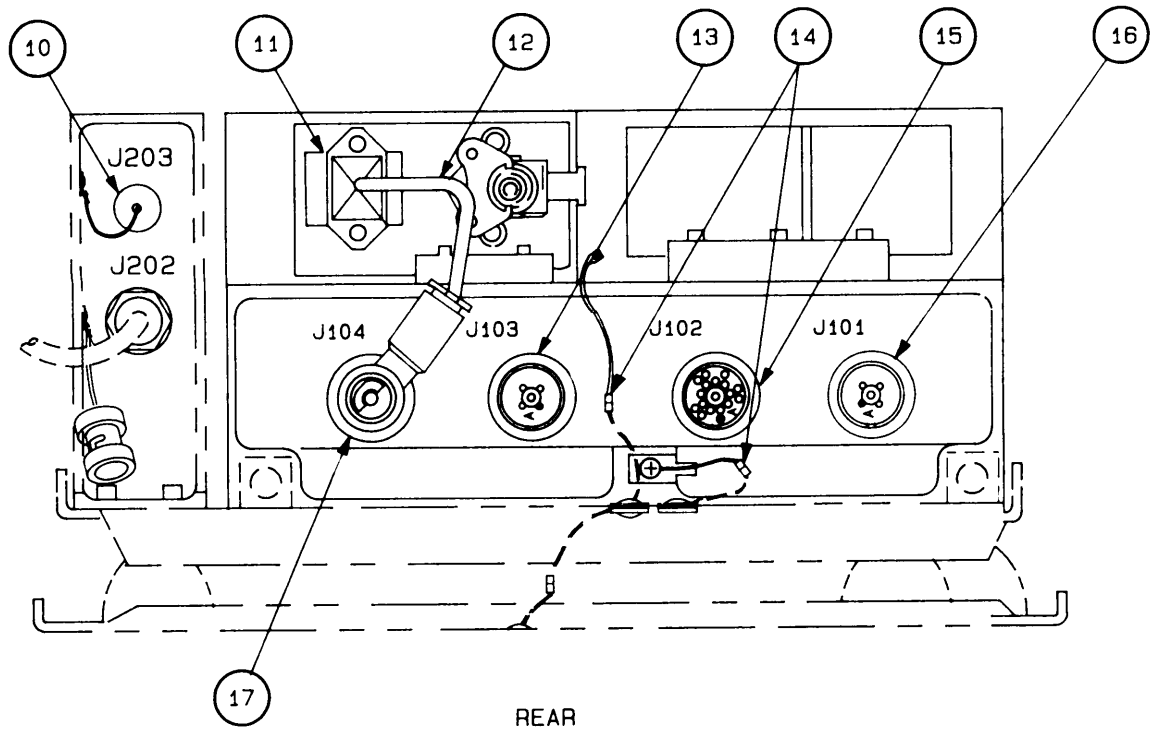
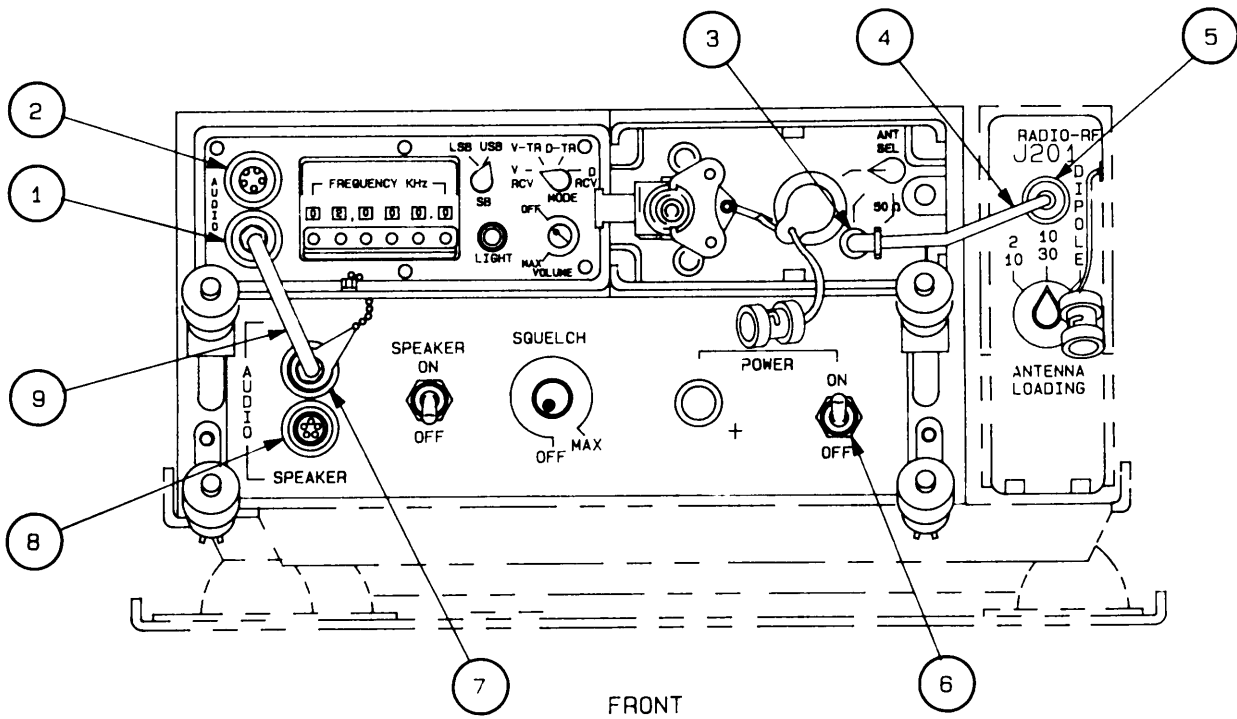

EL9WX013

Figure 2-11. Connector/Cable Location Diagram for Installation

g. If a loudspeaker is to be used in vehicle, connect loudspeaker to SPEAKER AUDIO connector (8, fig. 2-11) on amplifier-power supply.

h. Connect a handset to upper AUDIO connector (2, fig. 2-11) on front of receiver/exciter. (The handset, or a second handset, maybe connected to SPEAKER AUDIO connector (8, fig. 2-11) on front of amplifier-power supply if loudspeaker is not used.)

i. If AN/VIC-1(V) system is to be used, make the following connections:

(1) Connect intercommunication cable (part of installation kit) to connector J102 (15, fig. 2-11) on rear of amplifier-power supply. Verify that other end of intercommunication cable is connected to Audio Frequency Amplifier AM-1780/VRC (part of AN/VIC-1(V)) as described in Installation Instruction paragraph of TM 11-2300-476-14&P. If intercommunication cable is not properly connected to AN/VIC-1(V) unit, make connection per installation instructions.

(2) If AN/VIC-1(V) is to be used for the retransmit capability and the vehicular VHF FM radio power was not previously connected, connect vehicular VHF FM radio power cable to connector J103 (13, fig. 2-11) on rear of amplifier-power supply.

j. If a parallel radio set is to be used, connect its power cable to connector J103 (13, fig. 2-11) on rear of amplifier-power supply. Refer to paragraph 3-5, Operating Considerations, for antenna comparison. If whip antenna is used, connect antenna rf cable to J202 on rear of switching unit (part of installation kit).

k. Refer to paragraph 3-5, Operating Considerations, for antenna comparison. If dipole antenna is to be used in place of whip antenna, connect dipole rf cable to dipole antenna adapter. Connect dipole rf cable with adapter to connector J203 (10, fig. 2-11) on rear of switching unit (part of installation kit).

l. Refer to paragraph 3-5, Operating Considerations, for antenna comparison. Connect NVIS rf cable to connector J203 (10) on rear of switching unit (part of installation kit).

**2-4. Grounding Requirements.** For proper operation, the AN/GRC-213 must be properly grounded. Jumper cables with quick-release connectors (14, fig. 2-11) are provided with the installation kit and should be connected to the upper tray of the mounting base. Connect jumper cables to rear of receiver/exciter and amplifier-power supply as shown in figure 2-11.

**2-5. Minimum Performance Test.** To verify that all installation procedures and interconnections have been properly completed, perform the Minimum Performance Test outlined in paragraph 6-10.



## CHAPTER 3 OPERATING INSTRUCTIONS

### Section I. CONTROLS, VISUAL AND AUDIBLE INDICATORS, AND CONNECTORS

**3-1. General.** This section describes the controls, visual indicators, and connectors contained on the receiver/exciter, amplifier/coupler, and amplifier-power supply units. It also discusses the audible indicators, as heard in the handset and on the loudspeaker, which tell about the operational condition of the AN/GRC-213.

**3-2. Controls and Indicators.** The controls and indicators of the AN/GRC-213 are explained in subparagraphs a thru c.

a. *Receiver/Exciter.* The controls and indicators of the receiver/exciter (fig. 3-1) are listed in table 3-1.

b. *Amplifier/Coupler.* The controls and indicators of the amplifier/coupler (fig. 3-1) are listed in table 3-1.

c. *Amplifier-Power Supply.* The controls and indicators of the amplifier-power supply (fig. 3-1) are listed in table 3-1.

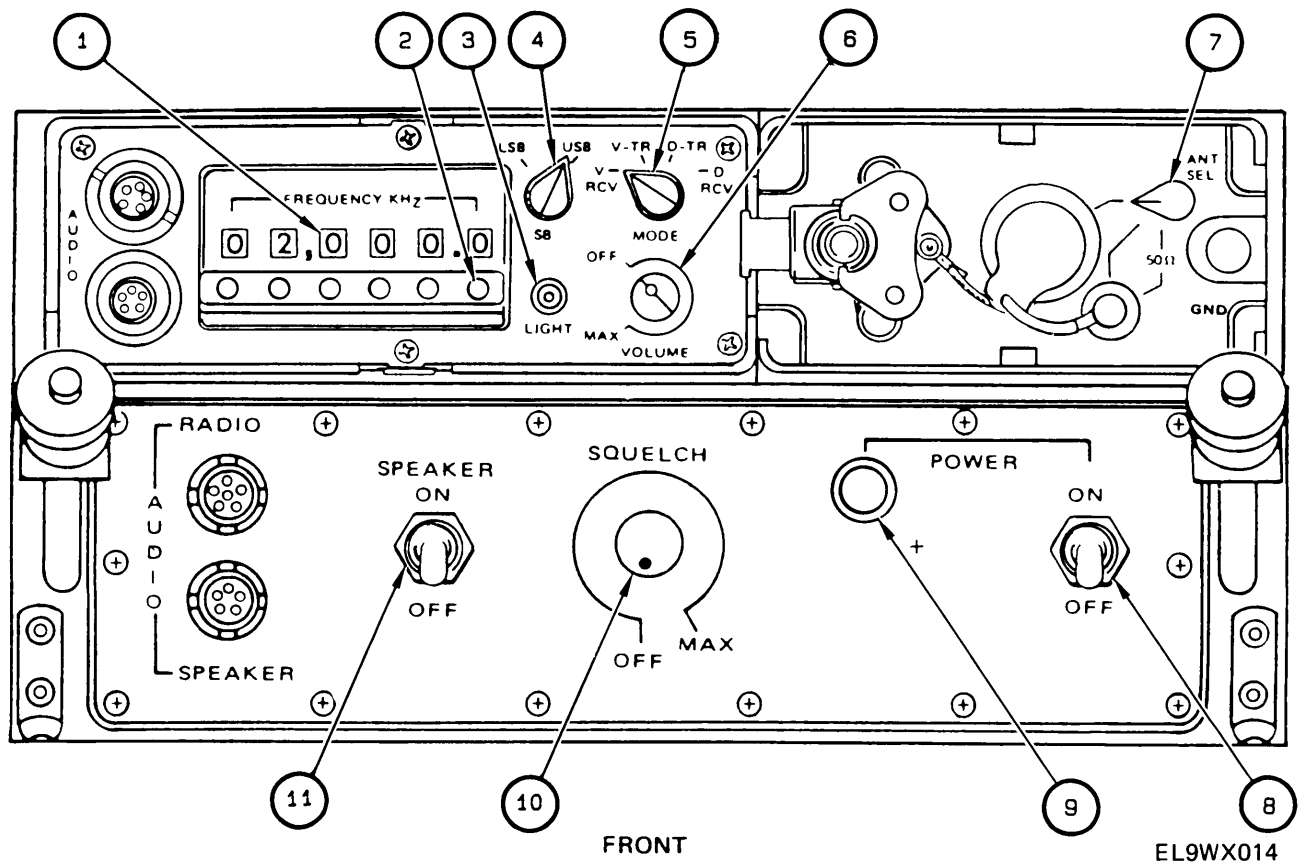

Figure 3-1. Controls and Indicators

Table 3-1. Controls and Indicators

Key	Control or Indicator	Function
RECEIVER/EXCITER		
1 & 2	FREQUENCY KHz switch	Selects 1 of 280,000 discrete frequencies between 2 and 29.9999 MHz in 100-Hz steps.
3	LIGHT switch	When pressed, lights FREQUENCY KHz read-out (with red light).
4	SB switch	Selects either USB (upper side band) or LSB (lower sideband) operation.
5	MODE switch	Selects one of four modes of operation: VRCV - Voice and cw receive only V-TR - Voice and cw transmit and receive D-TR - Data transmit and receive D RCV - Data receive only
6	VOLUME OFF/MAX switch control	Turns power on or off and adjusts the audio (volume) level of the AN/PRC-104A: at OFF, power is removed; at MAX, audio level is maximum.
AMPLIFIER/COUPLER		
7	ANT SEL switch	Selects whip antenna socket (not used), BNC connector through antenna tuner (part of amplifier/coupler), or BNC connector with antenna tuner bypassed (emergency use 50 Ω impedance antennas only).
AMPLIFIER-POWER SUPPLY		
8	POWER circuit breaker	Circuit breaker switch turns power on and off and protects amplifier-power supply from overcurrent conditions.
9	POWER switchlight	Indicates presence of conditioned power when light is lit (rotating lens counterclockwise brightens light).
10	SQUELCH control	Turns squelch on or off and sets level at which audio will be squelched or unsquelched: at OFF squelch is removed; at MAX, squelch level is maximum.
11	SPEAKER switch	Turns audio on or off to loudspeaker.

**3-3. Audible Indicators.** Five distinctive audio signals in the handset earpiece (and some in the Loudspeaker) are provided to tell the trained operator about the operational condition of the AN/GRC-213.

a. Low Voltage Indicator. On a properly operating AN/GRC-213, a repetitive clicking sound in the handset earpiece or over the loudspeaker indicates that the vehicle power source output voltage has fallen to less than 20 volts. The clicking sound will first be heard during a tune up or voice transmission. The sound will stop when the push-to-talk (PTT) switch is released and the AN/PRC-104A reverts to receive conditions where the power drain is at a minimum. At this point, the vehicle power system retains only enough charge for limited transmission and reception. When the output voltage level falls low enough that the clicking sound is heard continuously in the receive mode, the vehicle power system needs maintenance.

b. Power Output Indicator. If, while transmitting, the operator hears a voice in the handset earpiece, it is called sidetone. The presence of sidetone guarantees that the AN/PRC-104A is generating an rf signal and the power output to the antenna group is within 3 dB (50%) of the normal limits. The absence of sidetone during transmission means the handset or AN/PRC-104A is defective.

c. Tuning Indicator. The tuning indicator is a continuous 1-KHz tone that is heard in the handset earpiece or over the loudspeaker. This tone is typically heard for three seconds when the following occurs:

- the AN/GRC-213 is first turned on and the PTT switch is pressed,
- the FREQUENCY KHz settings (except for 0.1 KHz) are changed on the receiver/exciter control panel, or
- the MODE switch is set to V-TR or D-TR.

When the tone ceases, an increase in receiver noise level (static) indicates the antenna has been matched and the AN/PRC-104A is now receiving atmospheric noise. If the tone ceases but the receiver noise level does not increase, the antenna group (selected antenna, switching unit, and rf cables) is open, shorted, or otherwise faulty.

d. Tune Fault Indicator. If the tuning tone continues for a long time (8 thru 12 seconds) and a tune fault, consisting of a series of beeps, is heard after the tuning stops with no evident atmospheric noise (static), the tuner has failed to tune. The beeping tune fault tone may be caused by the following:

- Selecting a frequency below 2 MHz
- An open or short in the antenna group (selected antenna, switching unit, and rf cables)
- An antenna not suitable for the frequency in use
- Antenna obstructions

- Improper setting on the ANTENNA LOADING switch on the switching unit
- Malfunction of the amplifier/coupler in the antenna tuner circuitry

e. VSWR Indicator. The vswr indicator is a singular, short beep heard in the handset earpiece at the beginning of a transmission. The meaning of the beep depends on the setting of the ANT SEL switch on the amplifier/coupler as explained in the following subparagraphs.

(1) *Normal Vehicular Operation.* If the ANT SEL switch is in the center position, the beep indicates a previous momentarily high vswr condition. The high vswr condition can occur if the antenna or its immediate environment is disturbed. Such a disturbance causes the antenna's impedance to change, which produces the high vswr (unmatched) condition. The antenna tuner will measure the vswr at the beginning of the next transmission and will retune if the impedance change is permanent.

(2) *Antenna Tuner Bypassed.* If the ANT SEL switch is in the 50 Ω position, which bypasses the antenna tuner, the beep indicates the antenna vswr is higher than 4 to 1, but may still provide useful communications.

**3-4. Connectors.** The connectors of the AN/GRC-213 are explained in subparagraphs a thru c.

a. Receiver/Exciter. The connectors on the receiver/exciter (fig. 3-2) are listed in table 3-2.

b. Amplifier/Coupler. The connectors on the amplifier/coupler (fig. 3-2) are listed in table 3-2.

c. Amplifier-Power Supply. The connectors on the amplifier-power supply (fig. 3-2) are listed in table 3-2.

Table 3-2. Connectors

Key	Connector	Function
Receiver/Exciter		
1	AUDIO connector (lower)	Connects AN/PRC-104A to amplifier-power supply.
2	AUDIO connector (upper)	Connects receiver/exciter to handset in normal operation.
3	Receiver/Exciter interface connector P1	Connects receiver/exciter to amplifier/coupler (not shown).
4	Amplifier/Coupler interface connector J1	Connects amplifier/coupler to receiver/exciter (not shown).



TABLE 3-2. CONNECTORS - Continued

Key	Connector	Function
<b>Amplifier/Coupler</b>		
5	Whip antenna socket	Connects AN/PRC-104A to whip antenna in manpack operation (not used here).
6	BNC connector	Connects AN/GRC-213 to switching unit.
7	Ground terminal	Ground point for earth ground (not used here).
8	AN/PRC-104A power input connector	Connects AN/PRC-104A to AN/PRC-104A power connector J104 on amplifier-power supply.
<b>Amplifier/Power Supply</b>		
9	RADIO AUDIO connector	Connects amplifier-power supply to AN/PRC-104A.
10	SPEAKER AUDIO connector	Connects amplifier-power supply to loudspeaker (or handset).
11	J103 connector	Auxiliary power connector - Connects another radio set in parallel with the amplifier-power supply input power.
12	Grounding jumper cables	Connect AN/PRC-104A and amplifier-power supply to mounting base for grounding.
13	J102 connector	AN/VIC-1(V) interface connector - Connects amplifier-power supply to AN/VIC-1(V).
14	J101 connector	Input power connector - Connects amplifier-power supply to vehicle power source.
15	J104 connector	AN/PRC-104A power connector - Connects conditioned power from amplifier-power supply to AN/PRC-104A.

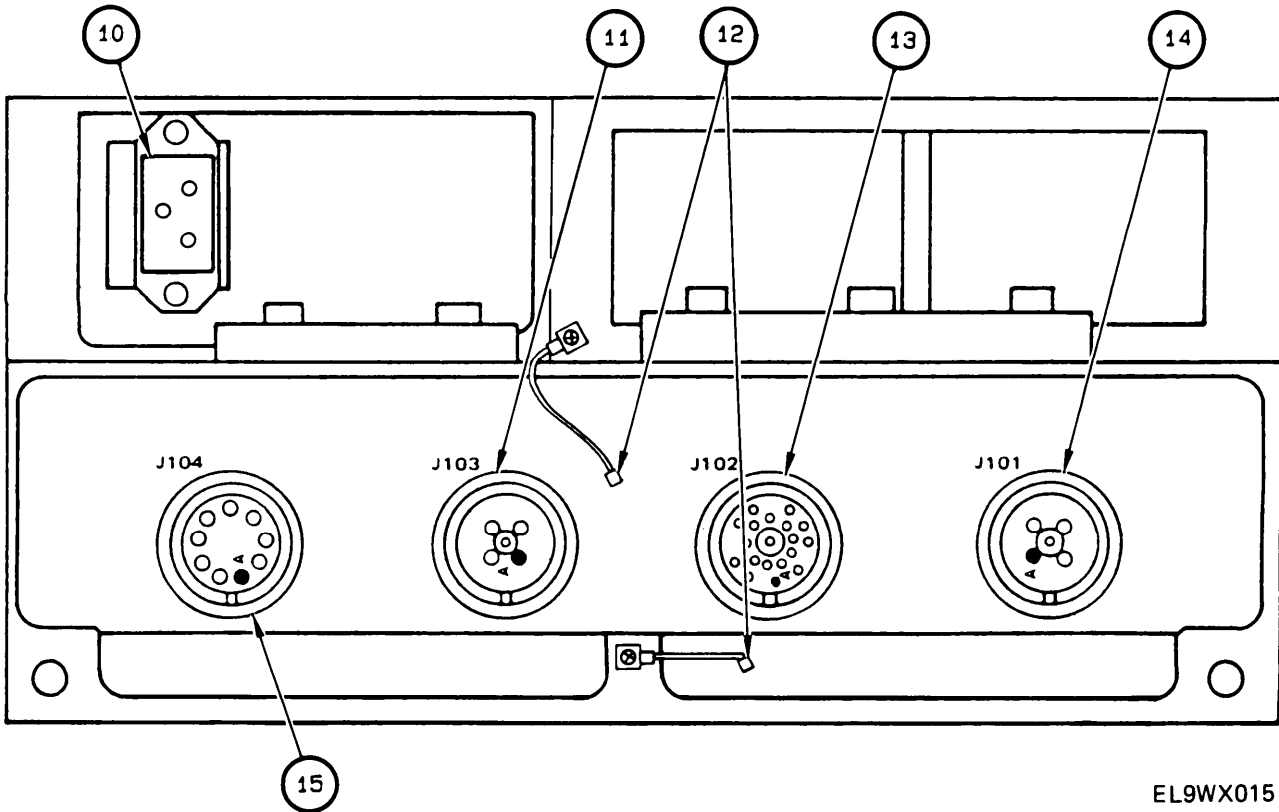
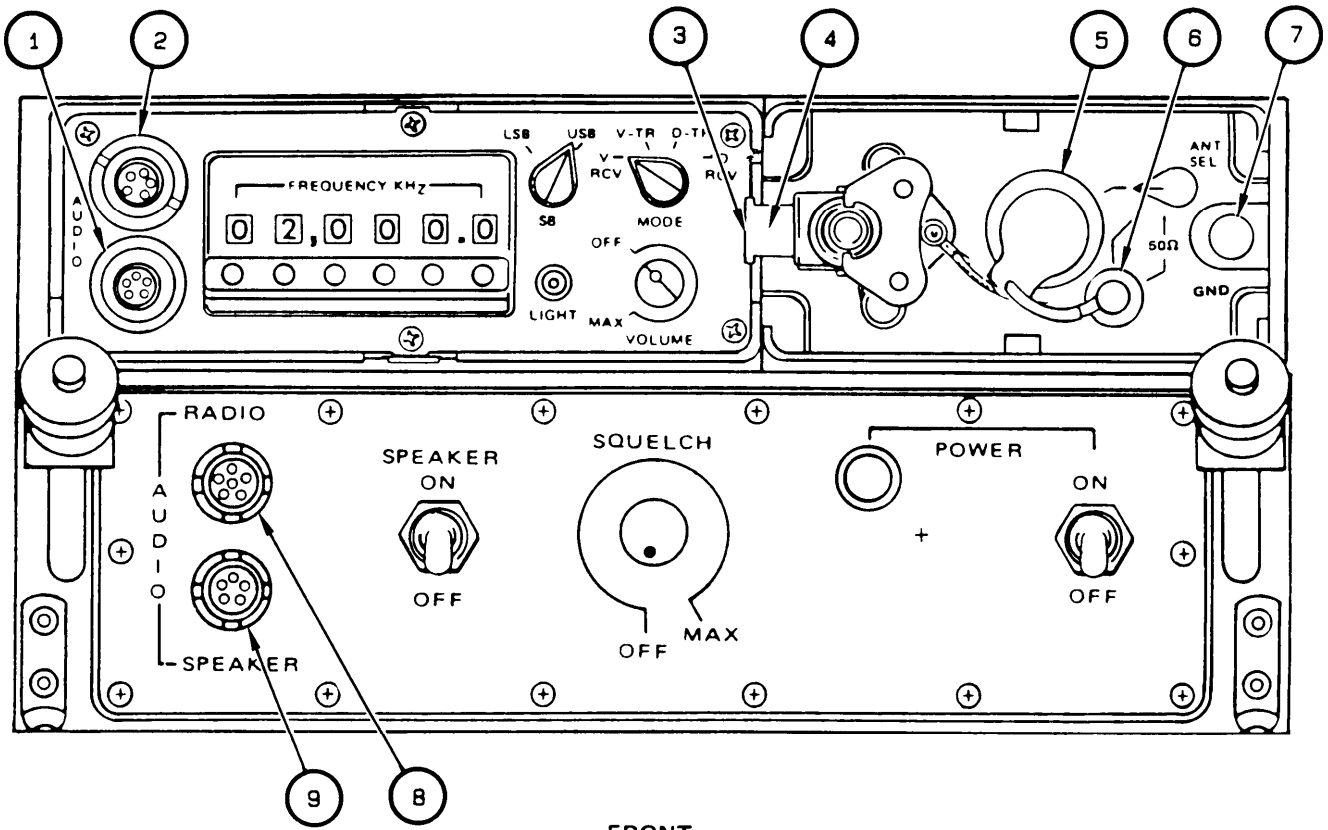

EL9WX015

Figure 3-2. Connectors

## Section II. OPERATION

**3-5. Operating Considerations.** Prior to performing initial checks for operating the AN/GRC-213, it is important to optimize the operating conditions to increase the reliability and effectiveness of radio communications. For instructions on selecting the best location and frequency for existing conditions, refer to the following paragraphs in TM 11-5820-919-12: Site Selection, Frequency Selection, and Optimizing Communication with the AN/PRC-104. Always select the best possible antenna based on the particular time, space, and terrain. Refer to the following subparagraphs for advantages and disadvantages of each antenna.

a. Dipole Antenna. The dipole antenna (fig. 3-3A) is the most effective of the three antennas. The advantages of the dipole antenna are as follows:

- Good gain; extended range (0 to 300 miles)
- Quickly assembled and erected

The disadvantages of the dipole antenna areas follows:

- Requires one or two vertical supports (depending upon configuration chosen)
- Basically bidirectional (perpendicular to the wire) requiring proper orientation for sensitivity indirection of other radio set(s)
- Not already installed with installation kit (TM 11-2300-476-14&P)
- Cannot be used when vehicle is moving

b. NVIS Antenna. The NVIS antenna (fig. 3-3B) is more efficient than the whip antenna. The advantages of the NVIS antenna are as follows:

- Good gain; extended range (0 to 300 miles)
- Omnidirectional (360 degree radiation pattern); does not need to be oriented for sensitivity indirection of other radio set(s).

The disadvantages of the NVIS antenna areas follows:

- Requires a large clear area (60 feet square) for proper operation
- Fully tuned only between frequencies of 2 and 12 MHz (may be used at frequencies above 12 MHz, but may not work at all frequencies)
- Not already installed with installation kit (TM 11-2300-476-14&P); requires two people to assemble and erect
- Cannot be used when vehicle is moving

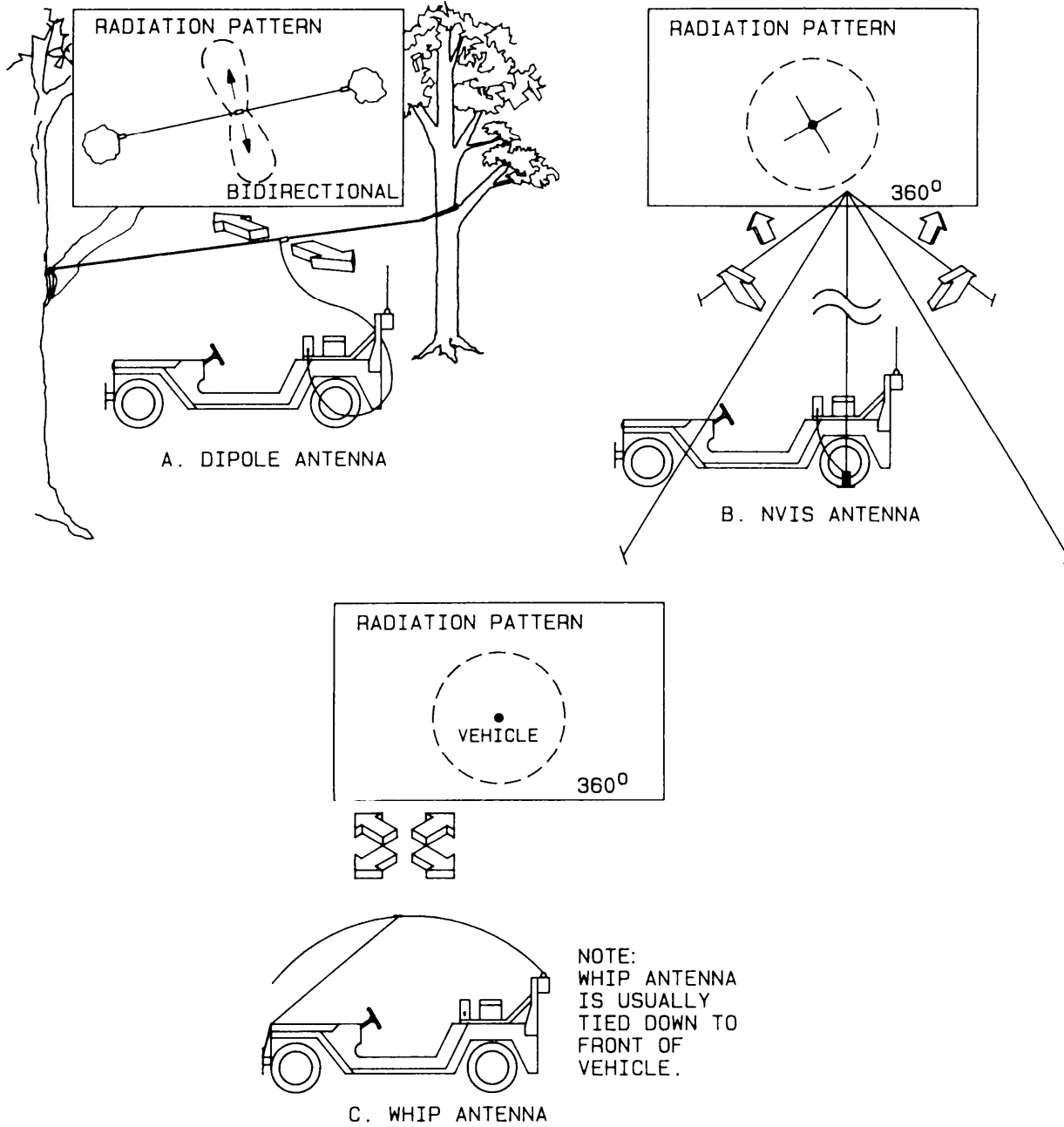

EL9WX016

Figure 3-3. Antenna Comparison

c. Whip Antenna. The whip antenna (fig. 3-3C) is the least effective of the three antennas from which the operator may choose. However, it is the most convenient antenna for the following reasons:

- Already installed with the installation kit (TM 11-2300-476-14&P)
- Allows communications while the vehicle is moving (other antennas do not)
- Omnidirectional (360-degree radiation pattern); does not need to be reoriented for sensitivity in direction of other radio set(s)
- Requires no support except for the vehicle mount.

The disadvantage of the whip antenna is that communications are restricted to short range (range maybe better under good propagation conditions).

**3-6. Initial Checks.** Verify that the following connections have been made. If necessary, make the connections as outlined.

- a. Verify that Visual Inspection has been completed as outlined in paragraph 5-2. If necessary, perform Visual Inspection.
- b. Verify that Minimum Performance Test has been completed as outlined in paragraph 6-8. If necessary, perform Minimum Performance Test.
- c. Audio cable is connected between lower AUDIO connector (1, fig. 3-4) on receiver/exciter and the RADIO AUDIO connector (17, fig. 3-4) on amplifier-power supply.
- d. RF cable is connected between BNC connector (8, fig. 3-4) on amplifier/coupler and RADIO-RF connector J201 (10, fig. 3-4) on switching unit (part of installation kit).
- e. If the power cable (part of installation kit) was not previously connected to connector J101 (23, fig. 3-4) on rear of amplifier-power supply, proceed as follows:
  - (1) For vehicles M577A1, M882, and M113A1, set vehicle master power switch to off position.



If the AN/GRC-213 is turned on in the following steps, current drawn may cause sparks that could damage the equipment.

- (2) Set POWER circuit breaker (12, fig. 3-4) on amplifier-power supply to OFF to turn off the AN/GRC-213.
- (3) Remove bag (if used) from power cable and connect cable to connector J101 (23, fig. 3-4) on rear of amplifier-power supply.

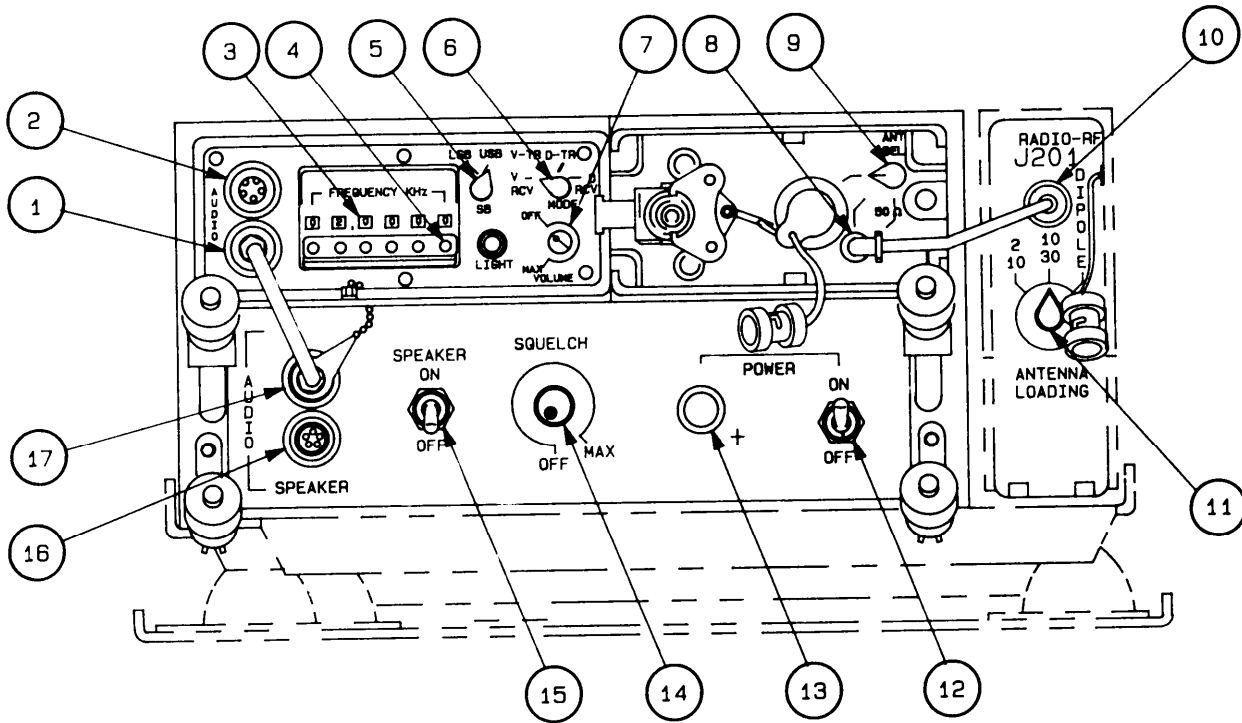

FRONT

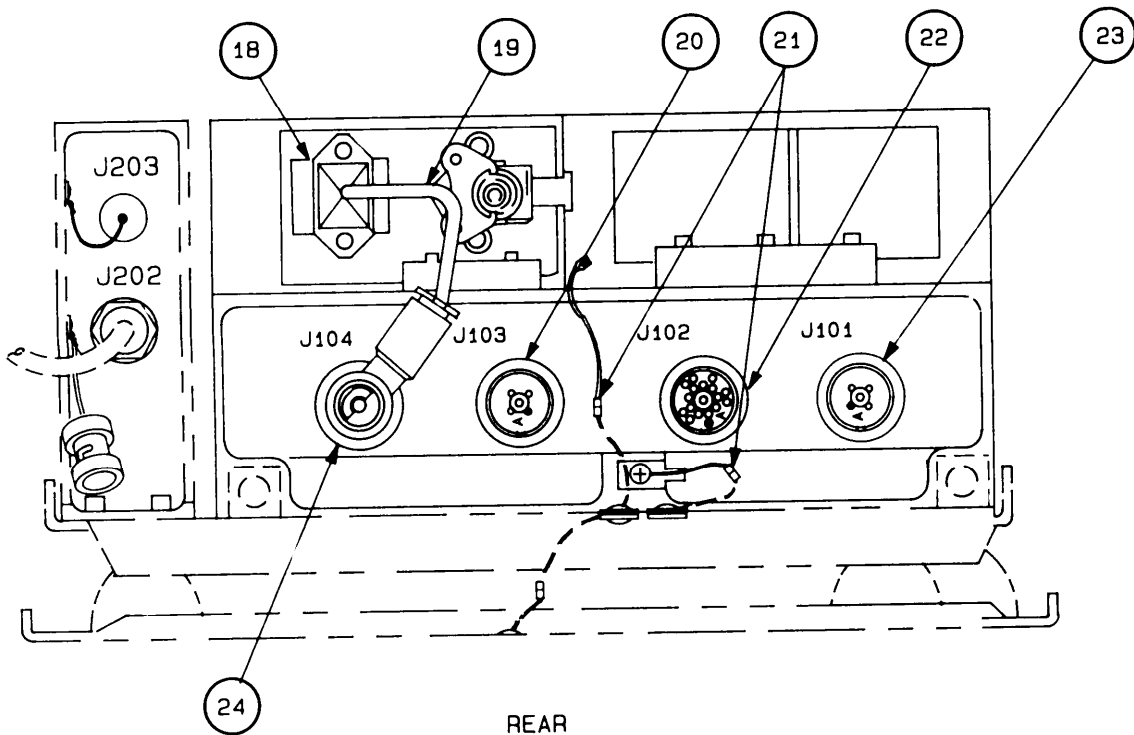

REAR

EL9WX017

Figure 3-4. Controls, Indicators, and Connectors for Operation

f. If AN/VIC-1(V) is used, intercommunication cable (part of installation kit) is connected to connector J102 (22, fig. 3-4) on rear of amplifier-power supply and to Audio Frequency Amplifier AM-1780/VRC as outlined in Installation Instructions paragraph of TM 11-230-476-14&P.

g. If parallel radio set is used, its power cable is connected to connector J103 (20, fig. 3-4) on rear of amplifier-power supply.

h. AN/PRC-104A power cable (19, fig. 3-4) is connected between connector J104 (24, fig. 3-4) on rear of amplifier-power supply and AN/PRC-104A power input connector (18, fig. 3-4) on rear of amplifier/coupler.

i. All quick-release ground connectors (21, fig. 3-4) are connected.

j. Handset is connected to upper AUDIO connector (2, fig. 3-4) on receiver/exciter. (Handset may be connected to SPEAKER AUDIO connector (16, fig. 3-4) if a loudspeaker is not connected here.)

k. Loudspeaker is connected to SPEAKER AUDIO connector (16, fig. 3-4) on amplifier-power supply. (A handset may be connected here, if desired.)

l. Antenna used is connected correctly. If the whip antenna is used, verify that it is connected and tied down properly. If necessary, connect or tie down the whip as outlined in Installation Instructions paragraph of TM 11-2300-476-14&P. If the dipole or NVIS antenna is used, verify that the antenna is connected properly as outlined by paragraph 2-3, Interconnections.

**3-7. Initial Control Settings.** Set the AN/GRC-213 controls to the position indicated in the following subparagraphs.

a. AN/PRC-704A. Set the AN/PRC-104A controls as follows:

(1) MODE switch (6, fig. 3-4) to V-TR

(2) ANT SEL switch (9, fig. 3-4) to BNC connector (8, fig. 3-4) middle position

(3) SB switch (5, fig. 3-4) to either USB or LSB

(4) FREQUENCY KHz switches (4, fig. 3-4) to a frequency between 2 and 29.9999 MHz. Frequency setting should be displayed in indicator windows (3, fig. 3-4).

b. Amplifier-Power Supply. Set the amplifier-power supply SPEAKER switch (15, fig. 3-4) to ON if loudspeaker is used, or to OFF if handset or nothing is connected to SPEAKER AUDIO connector (16, fig. 3-4).

c. Switching Unit. Set the switching unit (part of installation kit) ANTENNA LOADING switch (11, fig. 3-4) to appropriate position, determined by the frequency and antenna selected, as follows:

(1) Whip antenna:

For a frequency of 2 to 10 MHz, set switch to 2/10 (extreme left) position.

For a frequency of 10 to 29.9999 MHz, set switch to 10/30 (center) position.

(2) NVIS or Dipole Antenna:

For any frequency, set switch to DIPOLE (extreme right) position.

**3-8. Startup.** For normal operation, set the AN/GRC-213 controls as follows:

- a. POWER circuit breaker (12, fig. 3-4) to ON.
- b. Verify POWER switch light (13, fig. 3-4) is lit. (Rotating lens counterclockwise brightens light.)
- c. VOLUME OFF/MAX (14, fig. 3-4) switch control (7, fig. 3-4) to midrange or a comfortable listening position.
- d. SQUELCH control (14, fig. 3-4) on amplifier-power supply turned fully counterclockwise and then adjusted clockwise until background noise is quieted.

**3-9. Operation Under Normal Conditions.** Instructions for operation of the AN/GRC-213 under normal conditions are contained in the following subparagraphs. Instructions for operation with a handset, remote handset, data coding device, cw key, and retransmit mode are provided.

a. Operation With Handset. For normal two-way voice communication, the AN/GRC-213 should be operated in the V-TR mode with the handset connected to the upper AUDIO connector on the receiver/exciter. (Handset may be connected to SPEAKER AUDIO connector on the amplifier-power supply if a loudspeaker is not connected here.) To operate the AN/GRC-213, proceed as follows:

- (1) Verify initial cable connections (para 3-6) and initial control settings (para 3-7) are correct.
- (2) Press and release PTT switch on handset to begin tuning the AN/PRC-104A to the antenna.

#### NOTE

A series of beeps may be heard in the handset and loudspeaker following the tuning indicator in the following step. These beeps signify a tune fault has occurred. (Refer to paragraph 3-3d, Tune Fault Indicator.)

- (3) Verify that a continuous 1-kHz tone (tuning indicator) is heard in the handset receiver for a period of 3 seconds, typical, depending on frequency of operation selected. (A higher operating frequency will reduce the time that the 1-kHz tone is heard and a lower operating frequency will increase the time that the 1-kHz tone is heard.) If no tone is heard, press and release the PTT switch again.



(4) Press and hold PTT switch on handset and speak into the handset microphone to transmit. Microphone audio should be heard in the handset receiver as sidetone.

#### NOTE

A singular short beep (VSWR indicator) maybe heard at the beginning of transmission. (Refer to para 3-3e, VSWR Indicator).

(5) Release PTT switch to hear a reply from another radio set.

(6) Adjust SQUELCH control if necessary (14, fig 3-4), on loudspeaker to hear (receive) distant (weak) radio sets and to reduce background noise.

b. Operation With a Remote Handset. The AN/VIC-1(V) has provisions for connecting several handsets to the amplifier-power supply to enable remote stations within the vehicle to receive and transmit using the AN/GRC-213. Verify that all connections and initial control settings for remote handset operation are correct on the AN/VIC-1(V) per TM 11-5830-340-12. Except for the location of the handset(s), operation with remote handsets is the same as outlined in paragraph 3-9.

c. Operation With Data Coding Device or CW Key. To transmit and receive data or Morse code, proceed as outlined in the following subparagraphs.

(1) *Data Transceive.* When data communication is desired, proceed as follows:

- (a) Set MODE switch (6, fig. 3-4) on receiver/exciter to D-TR position.
- (b) Disconnect handset from upper AUDIO connector (2, fig. 3-4) on receiver/exciter. (Handset is not used in D-TR mode.)
- (c) Connect a data coding device, such as a modem or TTY converter, to upper AUDIO connector (2, fig. 3-4) on receiver/exciter. The AN/GRC-213 will now transmit and receive coded data.

(2) *Telegraph Communications.* When conditions require the use of International Morse code communication (cw), proceed as follows:

- (a) Set MODE switch (6, fig. 3-4) on receiver/exciter to V-TR position.
- (b) Disconnect handset from upper AUDIO connector (2, fig. 3-4) on receiver/exciter.
- (c) Connect cw key to upper AUDIO connector (2, fig. 3-4) on receiver/exciter.



Do not leave cw key down continuously for over one minute during operation to avoid heat buildup. Heat buildup could damage the amplifier/coupler and reduce rf output power.

- (d) Connect either a loudspeaker or handset to SPEAKER AUDIO connector (16, fig. 3-4) on amplifier-power supply to monitor received and transmitted code. The operator may now transmit and receive International Morse code with the AN/G RC-213.

d. Operation in the Retransmit Mode. The AN/GRC-213 may be interfaced with the AN/VIC-1(V) and a VHF FM radio set in the vehicle to provide an automatic retransmit mode. This mode allows signals from remote HF SS6 radio(s) to be received and retransmitted as VHF to remote VHF FM radio(s) or vice versa. To use the retransmit mode of operation, proceed as follows:

- (1) Verify initial cable connections (para 3-6) and control settings (para 3-7) are correct. If necessary, make the connections and control settings as needed.

- (2) Verify AN/VIC-1(V) and vehicular VHF FM radio set are connected properly for retransmit operation. (Refer to TM 11-5820-401-35-1.) If necessary, make connections as needed.

- (3) Set the controls to position indicated in the following subparagraphs.

- (a) *AN/GRC-213.* Set the AN/GRC-213 controls and tune as follows:

- (1) Set POWER circuit breaker (12, fig. 3-4) on amplifier-power supply to ON.

- (2) Set SQUELCH control (14, fig. 3-4) to level (turning clockwise) where signal received from HF radio set(s) just breaks. squelch.

- (3) Set FREQUENCY KH, switches (4, fig. 3-4) to operating frequency of remote HF radio set.

- (4) Press and release PTT switch on handset to begin tuning the AN/PRC-104A to the antenna.

#### NOTE

A series of beeps may be heard in the handset and loudspeaker following the tuning indicator in the following step. These beeps signify a tune fault has occurred. (Refer to para 3-3d, Tune Fault Indicator.)

(5) Verify that a Continuous 1-KHz tone (tuning indicator) is heard in the handset receiver and over the loudspeaker for a period of 3 seconds, typical, depending on frequency of operation selected. (A higher operating frequency will reduce the time that the 1-KHz tone is heard and a lower operating frequency will increase the time that the 1 -KHz tone is heard.) If no tone is heard, press and release the PTT switch again.

(b) *AN/VIC-1(V)*. Set the AN/VIC-1(V) controls as follows:

(1) Verify INSTALLATION SWITCH on the Audio Frequency Amplifier AM-1780/VRC is set to RETRANS. If necessary, set switch to RETRANS.

(2) Set POWER CKT BKR switch on Audio Frequency Amplifier AM-1780 (part of AN/VIC-1(V)) to ON.

(3) Set RETRANS switch on Radio Set Control C-2299/VRC (part of AN/VIC-1(V)) to ON.

(c) *Vehicular VHF FM Radio Set*. Set vehicular VHF FM radio set controls as outlined in operator manual. Verify that function switch is set to retransmit position (if available) and frequency is set to operating frequency of remote VHF FM radio set.

(d) *Remote HF Radio set*. Set remote HF radio set controls as outlined in operator manual. Verify that function switch is set to voice transmit and receiver (or retransmit) and frequency is set to operating frequency of the AN/GRC-213.

(e) *Remote VHF FM Radio Set*. Set remote VHF FM radio set controls as outlined in operator manual. Verify that function switch is set to retransmit (or voice transmit and receive) and frequency is set to operating frequency of vehicular VHF FM radio set. If necessary, set function or frequency settings.

(4) The vehicular system should now be set up to automatically retransmit HF and VHF FM radio signals. A handset may be used to monitor communications by connecting it to upper AUDIO connector (2, fig. 3-4) on receiver/exciter of AN/GRC-213.

**3-10. Operation Under Radio Silence.** When field conditions require that no radio transmissions be made, the MODE switch on the receiver/exciter should be set to V RCV or D RCV. These modes prevent the AN/GRC-213 from transmitting signals. When V RCV is selected, the AN/GRC-213 receives voice (or cw), but cannot transmit. When D RCV is selected, the AN/GRC-213 receives data information, but does not transmit data.

**3-11. Operation Under Unusual Conditions.** No special operating procedures are required for operation of the AN/GRC-213 in adverse weather conditions.

**3-12. Shutdown.** To shutdown operation of AN/GRC-213, set controls to the following positions:

a. POWER circuit breaker (12, fig. 3-4) on the amplifier-power supply to OFF. The power light (13, fig. 3-4) should go off.

b. VOLUME OFF/MAX switch control (7, fig. 3-4) on the receiver/exciter to OFF.

## CHAPTER 4

### THEORY OF OPERATION

**4-1. General.** This chapter discusses the theory of operation of the AN/GRC-213. Section I contains a block diagram and general functional description of the signal flow between the AN/GRC-213 units, accessories, and auxiliary equipment. Also provided is a description of antenna wave propagation for the three supplied antennas. Section I also contains block diagrams and general functional descriptions of the AN/GRC-213 interface with the AN/VIC-1(V) to provide remote handset and retransmit capabilities. Section II contains a functional schematic and detailed functional description for each of the AN/GRC-213 units.

## Section I. AN/GRC-213 GENERAL FUNCTIONAL DESCRIPTION

**4-2. AN/GRC-213 General Functional Description.** (See fig. 4-1.) The AN/GRC-213 units, accessories, and auxiliary equipment are illustrated in figure 4-1. The corresponding general theory of operation is contained in the subparagraphs below.

a. Transmit Signals. Signals to be transmitted by the AN/GRC-213 are input to the receiver/exciter as XMT AUDIO. The XMT AUDIO signal is either input from the cw key, the handset where it has been developed from the mouthpiece, or from the amplifier-power supply where it has been developed by attenuating and filtering the AMPLIFIED XMT AUDIO signal from the AN/VIC-1(V). XMT AUDIO is routed back to the handset and amplifier-power supply as SIDETONE AUDIO and from the amplifier-power supply to the AN/VIC-1(V) as MONITOR AMP for user transmission monitoring. XMT AUDIO is also modulated by the receiver/exciter to produce XMT RF. This signal is routed to the amplifier/coupler which amplifies and outputs the signal to the antenna via the switching unit (part of installation kit, TM 11-2300-476-14&P).

b. Received Signals. Received rf signals are input from the switching unit (part of installation kit) to the amplifier/coupler and then the receiver/exciter as RCV RF. The RCV RF signal is demodulated to produce the RCV AUDIO signal, which is routed to the handset and amplifier-power supply. RCV AUDIO is routed by the amplifier-power supply to the AN/VIC-1(V) as MONITOR AMP and UNMUTED AUDIO. RCV AUDIO is also amplified to one watt by the amplifier-power supply and output to the loudspeaker as AMPLIFIED RCV AUDIO.

c. PTT Signal. The PTT signal determines whether the AN/GRC-213 is in the receive or transmit mode of operation. The AN/GRC-213 is normally in the receive mode with the PTT line floating. When PTT drops low (ground potential), the AN/GRC-213 is put into the transmit mode. A low PTT signal can be input to the receiver/exciter directly from the handset when the PTT switch is pressed for tuning or transmitting; or it can be routed from the AN/VIC-1(V) through the amplifier-power supply when the AN/VIC-1(V) is transmitting. The PTT signal also drops low within the receiver/exciter when a CW (telegraph) signal is input from the cw key for transmission. The PTT signal is also present in the amplifier-power supply either directly from the AN/VIC-1(V) or from the handset via the receiver/exciter. In the amplifier-power supply a low PTT signal disables the RETRANSMIT signal. This insures that retransmission does not occur when either the AN/GRC-213 or VHF FM radio are transmitting. (The retransmit capability is for retransmission of received signals only - refer to para 4-3b.)

d. RETRANSMIT Signal. The RETRANSMIT signal is output to the AN/VIC-1(V) where it is used for retransmit operation (para 4-3b). The RETRANSMIT signal functions the same as a PTT signal. When it drops low (ground potential), it is routed through the AN/VIC-1(V) to the VHF FM radio to put the radio in the transmit mode for retransmission. The RETRANSMIT signal drops low when the PTT signal is floating (not low) and the RCV AUDIO signal removes squelch in the amplifier-power supply.

e. Antenna Radio Wave Propagation. The AN/GRC-213 and installation kit (TM 11-2300-476-14&P) are supplied with three antennas: vehicular whip, NVIS, and dipole. These antennas propagate radio waves in two ways: the ground wave and the skywave. While each antenna will propagate radio waves by both means to some extent, the NVIS antenna propagates primarily through skywaves and the other two, the whip and the dipole, propagate primarily through ground waves. Appendix II, Propagation of Radio Waves, in TM 11-5820-919-12, contains an explanation of both ground and skywave propagation. Also included in this appendix are discussions of Maximum Useable Frequency (MUF), Frequency of Optimum Transmission (FOT), Multi-skip Phenomenon, and HF Band Segments.

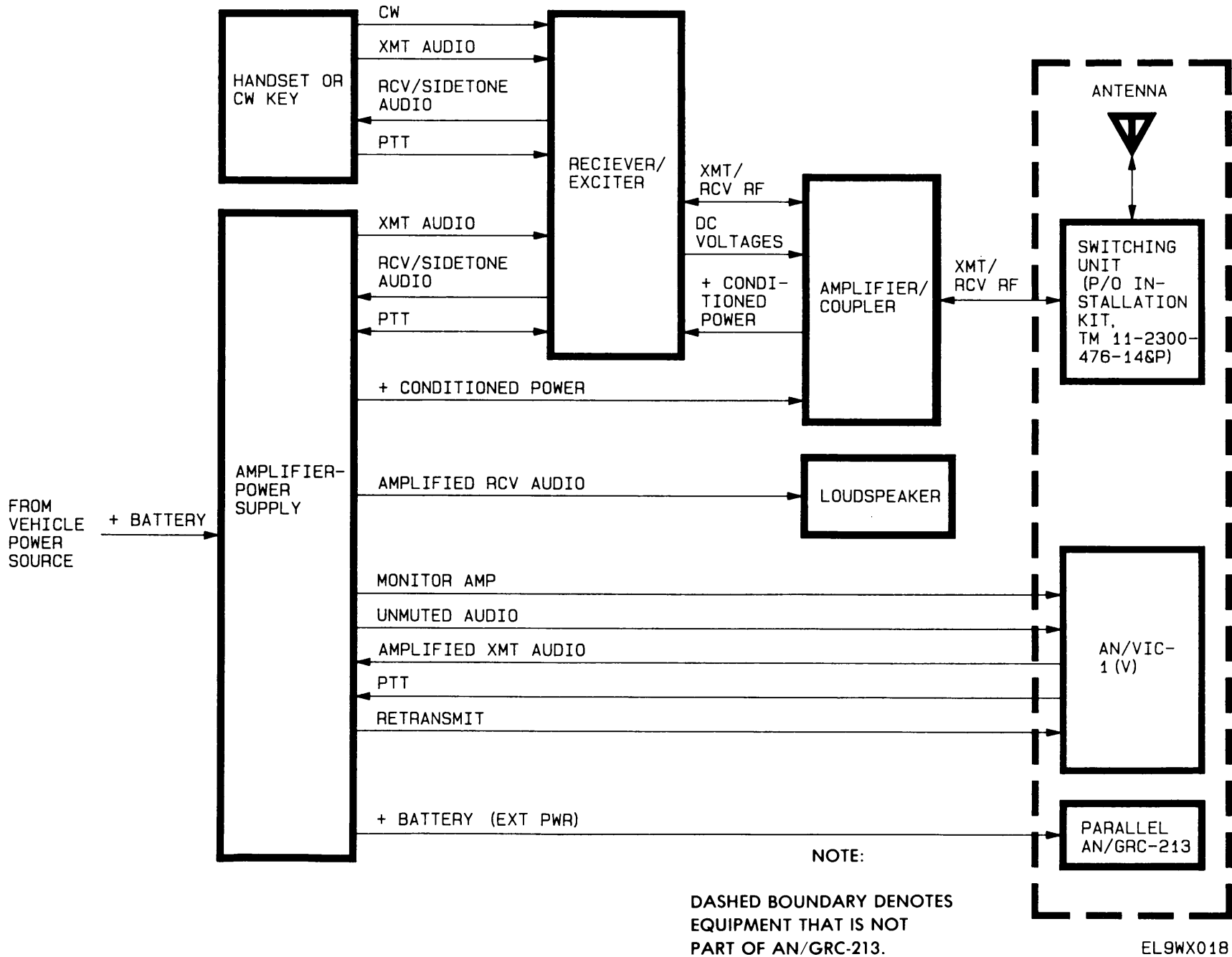

Figure 4-1. AN/GRC-213 Block Diagram

f. Power. Primary power for the AN/GRC-213 is provided by the power system of the vehicle in which the AN/GRC-213 is mounted. The + BATTERY power from the vehicle power source is input to the amplifier-power supply. This power is routed to a parallel AN/GRC-213 (if used) as + BATTERY (EXT PWR).

The input power is also conditioned by the amplifier-power supply to provide constant + CONDITIONED POWER which is routed to the amplifier/coupler and then the receiver/exciter. The receiver/exciter produces two switched DC VOLTAGES that are routed to the amplifier/coupler.

**4-3. AN/VIC-1(V) Interface General Functional Description.** (See fig. 4-2, 4-3). The AN/GRC-213 can be interfaced with the AN/VIC-1(V) to provide remote handset operation or retransmit operation. A general functional description with a block diagram is provided for each type of operation in the following two subparagraphs.

a. Remote Handset Operation. (See fig. 4-2). The AN/GRC-213 can be interfaced with the AN/VIC-1(V) as illustrated in figure 4-2 to provide the remote handset capability. This allows the AN/GRC-213 to be operated from remote stations within the vehicle. A functional description of remote handset operation is contained in the paragraphs below.

(1) Transmit Signals. The XMT AUDIO signal is developed from the handset mouthpiece and routed through Intercom Control Set C-2298/VRC to Audio Frequency Amplifier AM-1780/VRC. This signal is then amplified to produce the AMPLIFIED XMT AUDIO signal that is input to the amplifier-power supply. The amplifier-power supply attenuates the signal and routes it to the receiver/exciter for transmission. When the AN/GRC-213 output power is sufficient for transmission, the receiver/exciter routes a SIDETONE AUDIO signal back to the amplifier-power supply. The amplifier-power supply amplifies this signal to produce MONITOR AMP. MONITOR AMP is sent to Audio Frequency Amplifier AM-1780/VRC which attenuates it to retrieve the SIDETONE AUDIO signal. This signal is routed through Intercom Control Set C-2298/VRC to the handset earpiece. The earpiece converts the audio signals to audible tones for the user. The sidetone heard in the handset assures the operator the AN/GRC-213 is transmitting.

(2) Received Signals. During receive operation, the MONITOR AMP signal contains amplified RCV AUDIO. MONITOR AMP is routed from the amplifier-power supply to Audio Frequency Amplifier AM-1780/VRC. This unit attenuates the signal to produce RCV AUDIO. RCV AUDIO is then routed through Intercom Control Set C-2298/VRC to the handset earpiece, the same as SIDETONE AUDIO is routed in transmit operation.

(3) PTT Signal. The PTT signal is at ground potential when the PTT switch is pressed on the remote handset. This ground potential is routed through Intercom Control Set C-2298/VRC and Audio Frequency Amplifier AM-1780/VRC to the amplifier-power supply. The PTT input places the AN/GRC-213 in the transmit mode.

(4) Power. The emi (electromagnetic interference) filtered vehicle power, called + BATTERY (EXT PWR) is output by the amplifier-power supply to Audio Frequency Amplifier AM-1780/VRC. This unit distributes the power internally and also routes it to Intercom Control Set C-2298/VRC.



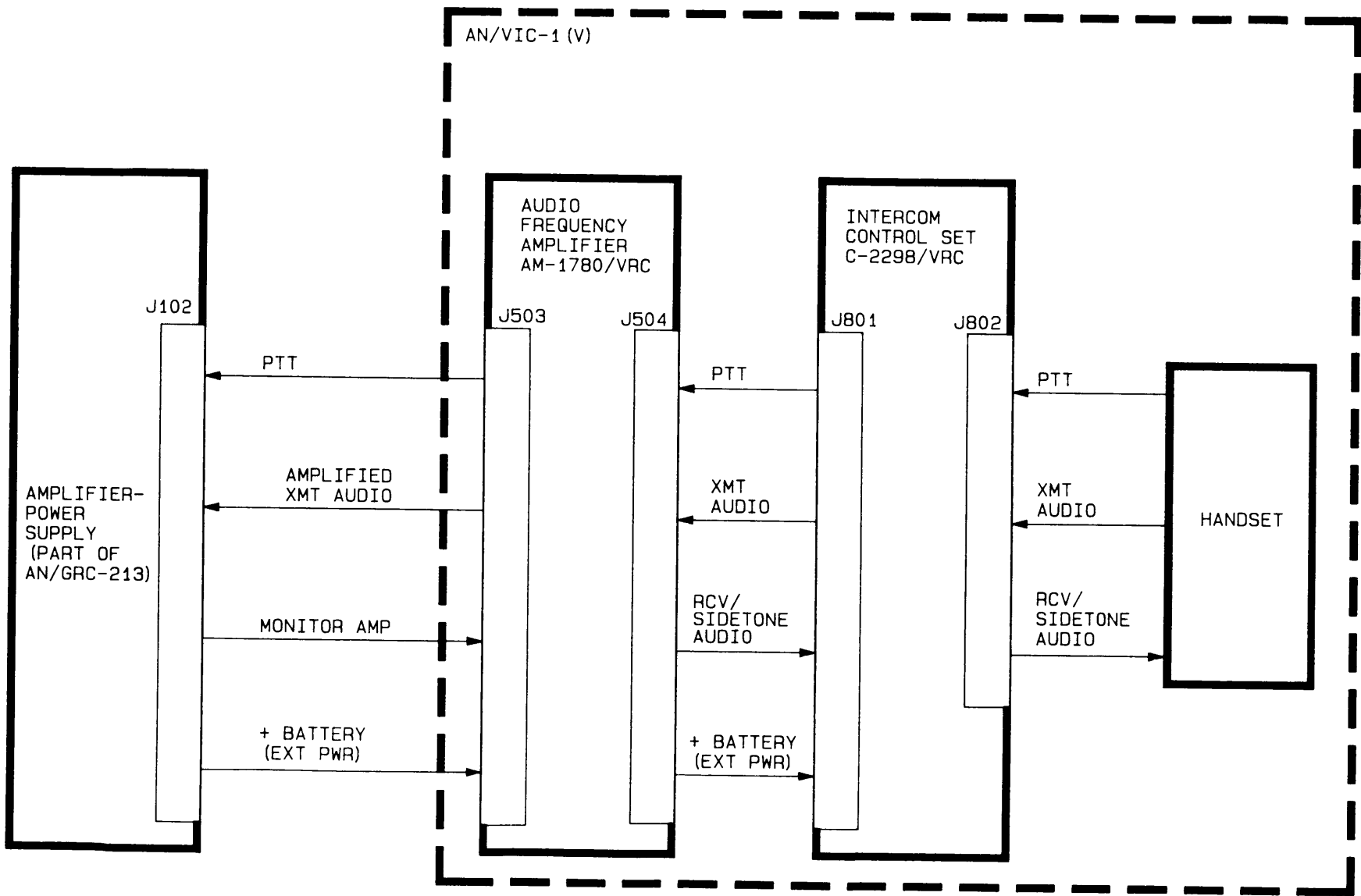

EL9WX019

Figure 4-2. Remote Handset Operation Block Diagram

b. Retransmit Operation. (See fig. 4-3). The AN/GRC-213 can be interfaced with the AN/VIC-1(V) and a VHF FM radio set, as illustrated in figure 4-3, to make retransmission possible. Retransmission allows automatic retransmission in the vhf band of received HF SSB signals and in HF SS6 of received VHF FM signals. The following paragraphs contain the functional description of retransmit operation.

(1) *Retransmission as VHF.* When retransmitting HF SSB signals as VHF FM signals, the AN/GRC-213 first receives the HF SSB signals transmitted by remote HF SSB radio set(s). If squelch is removed, the HF RETRANSMIT signal at ground potential is output by the amplifier-power supply. This HF RETRANSMIT signal is routed through Audio Frequency Amplifier AM-1780/VRC and Radio Set Control C-2299/VRC and is then called the VHF PTT Signal. The VHF PTT signal is sent back through Audio Frequency Amplifier AM-1780/VRC and input to the vehicular VHF FM radio set. The ground potential on VHF PTT puts the vehicular VHF FM radio set in the transmit mode. The HF SSB signals received by the AN/GRC-213 are sent to the AN/VIC-1(V) as HF UN MUTED AUDIO. These audio signals are routed through the two AN/VIC-1(V) units and provided to the VHF FM radio set as VHF AMPLIFIED XMT AUDIO. In the VHF FM radio set, these audio signals are attenuated, modulated, and transmitted at a vhf frequency. The transmitted VHF FM signals are received by remote VHF FM radio set(s).

(2) *Retransmission as HF SSB.* When retransmitting VHF FM signals as HF SSB signals, the vehicular VHF FM radio set receives the VHF FM signals transmitted by the remote VHF FM radio set(s). If squelch is removed, the VHF RETRANSMIT signal at ground potential is output by the vehicular VHF FM radio set. This VHF RETRANSMIT signal is routed through Audio Frequency Amplifier AM-1780/VRC and Radio Set Control C-2299/VRC and is then called the HF PTT signal. The HF PTT signal is sent back through Audio Frequency Amplifier AM-1780/VRC and input to the AN/GRC-213 amplifier-power supply. The ground potential input on HF PTT puts the AN/GRC-213 in the transmit mode. The VHF FM signals received by the vehicular VHF FM radio set are sent to the AN/VIC-1(V) as VHF AMPLIFIED UNMUTED AUDIO. These audio signals are routed through the AN/VIC-1(V) units and provided to the AN/GRC-213 as HF AMPLIFIED XMT AUDIO. The HF AMPLIFIED XMT AUDIO signals are input to the AN/GRC-213 to be attenuated, modulated, and transmitted at the selected HF frequency. The transmitted HF SSB signals are received by remote HF SSB radio set(s).

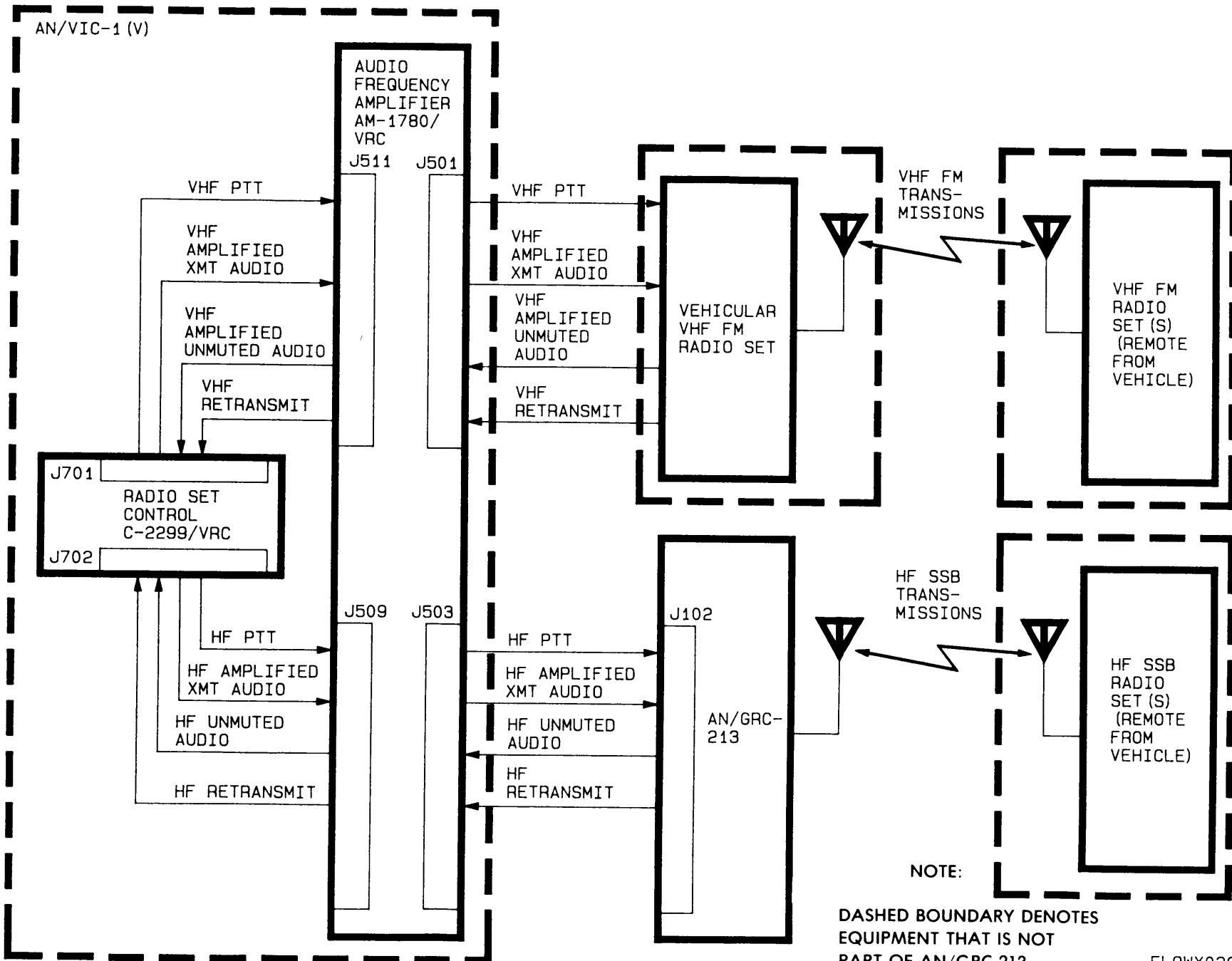

Figure 4-3. Retransmit Operation Block Diagram

EL9WX020

## Section II. AN/GRC-213 DETAILED FUNCTIONAL DESCRIPTION

**4.4. AN/GRC-213 Detailed Functional Description.** (See fig. 4-4 thru 4-7.) The following subparagraphs and figures provide a detailed functional description and a functional schematic for each unit within the AN/GRC-213.

a. *Receiver/Exciter.* (See fig. 4-4.) The receiver/exciter functional schematic, figure 4-4, illustrates the signal routing and conditioning in the receiver/exciter. The following paragraphs describe the signals.

(1) *Transmit Signals.* The signals to be transmitted are input as XMT AUDIO from the amplifier-power supply or handset and CW from the cw (telegraph) key. The XMT AUDIO and CW signals are filtered by the audio filter in the control panel and routed to the modulator/demodulator. This circuit attenuates the data signals (not voice or CW) by 32 dB. The modulator/demodulator also develops CW into a 1-ktiz torte. The signal to be transmitted (XMT AUDIO or a 1-kHz CW modulation tone) is converted (modulated) by the modulator/demodulator to an rf signal, XMT RF, by using the synthesizer's three LO (local oscillator) SIGNALS. The SB (sideband) switch controls one of the LO SIGNALS by sending an LSB signal (0 or +24 V) to the synthesizer. The synthesizer uses the LSB signal to switch between USB (upper sideband) (0 V) and LSB (lower sideband) (+24 V) operation.

The XMT RF signal is output to the amplifier/coupler to be amplified and returned to the receiver/exciter. The returned XMT RF signal (pin 16) is sent through the harmonic filter. This circuit removes transmitter harmonics prior to the signal being routed again to the amplifier/coupler for transmission.

The ALC (automatic level control) signal is input to the modulator/demodulator from the amplifier/coupler. The modulator/demodulator uses the ALC signal to maintain a constant level of XMT RF output. The ALC signal is derived from the V FWD (voltage forward) and V REFL (voltage reflected) voltages output by the harmonic filter. The V FWD voltage is proportional to the energy going to the antenna and the V REFL voltage to the energy reflecting back to the harmonic filter.

The XMT RF signal is also attenuated by the modulator/demodulator to produce the SIDETONE AUDIO signal. The SIDETONE AUDIO signal is applied to the RCV AUDIO signal path when a SIDETONE ENABLE signal is input. The SIDETONE ENABLE signal is input from the amplifier/coupler when power output is sufficient for transmission. The SIDETONE AUDIO signal is filtered in the control panel and output to the handset and amplifier-power supply. This output assures the operator the AN/GRC-213 is transmitting.

(2) *Receive Signals.* Received signals are input as RCV RF (pin 47) from the amplifier/coupler and routed through the harmonic filter to remove undesirable spurious signals. RCV RF is then output to the amplifier/coupler which returns the signal back to the receiver/exciter modulator/demodulator (pin 2). The modulator/demodulator uses three LO SIGNALS from the synthesizer to extract (demodulate) RCV AUDIO (data, voice, or CW) signals from the returned RCV RF. RCV AUDIO is then filtered by the audio filter in the control panel and sent to the handset and amplifier-power supply.

(3) *Keyline Signals.* The modulator/demodulator and MODE switch determine if the receiver/exciter operates in receive or transmit modes. The receiver/exciter can receive in either receive or transmit modes. In a receive mode, the modulator/demodulator leaves the KEY LINE and PA KEY LINE signal lines floating. If the MODE switch (fig. 4-4, sh 2) is set

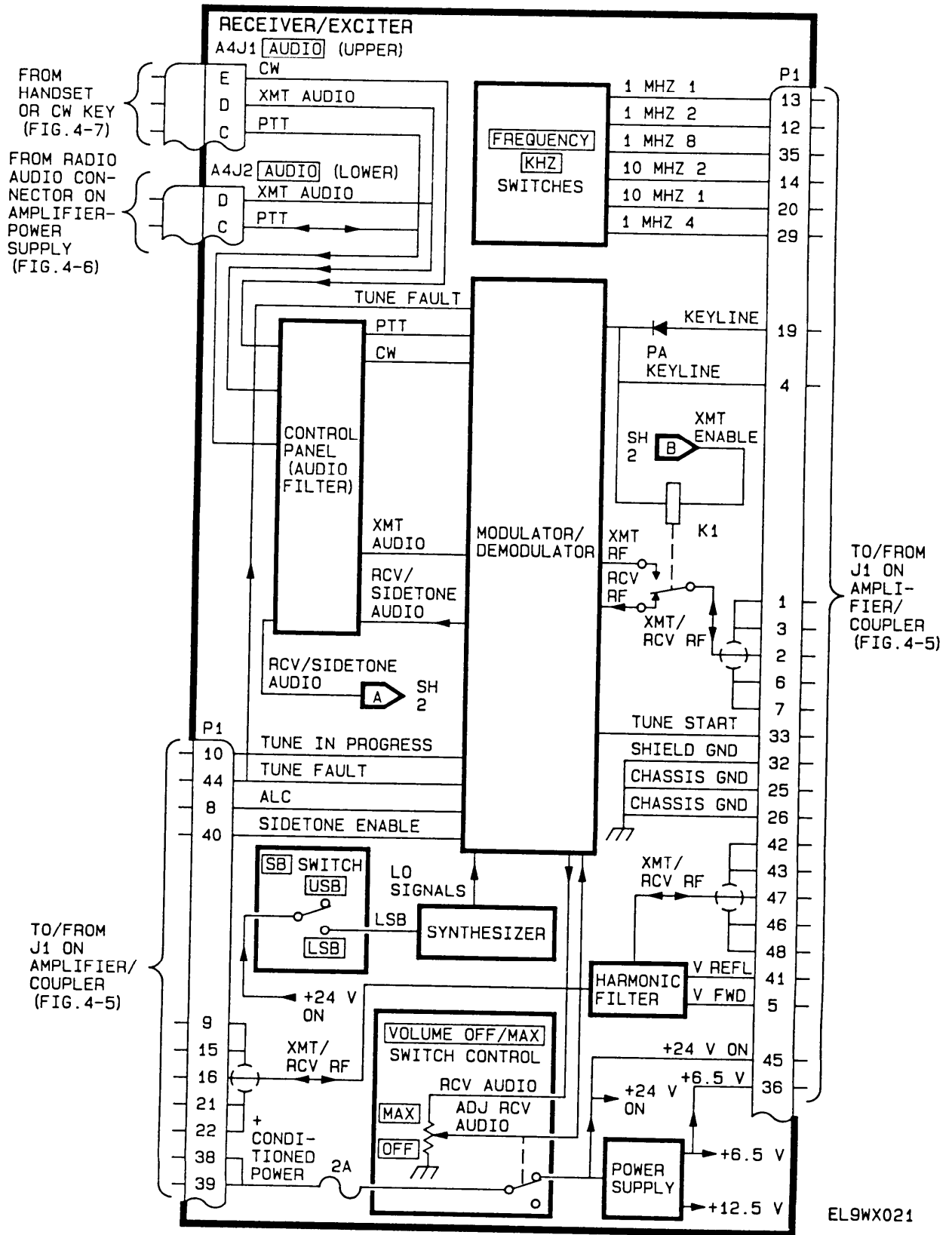

Figure 4-4. Receiver/Exciter Functional Schematic (Sheet 1 of 2)

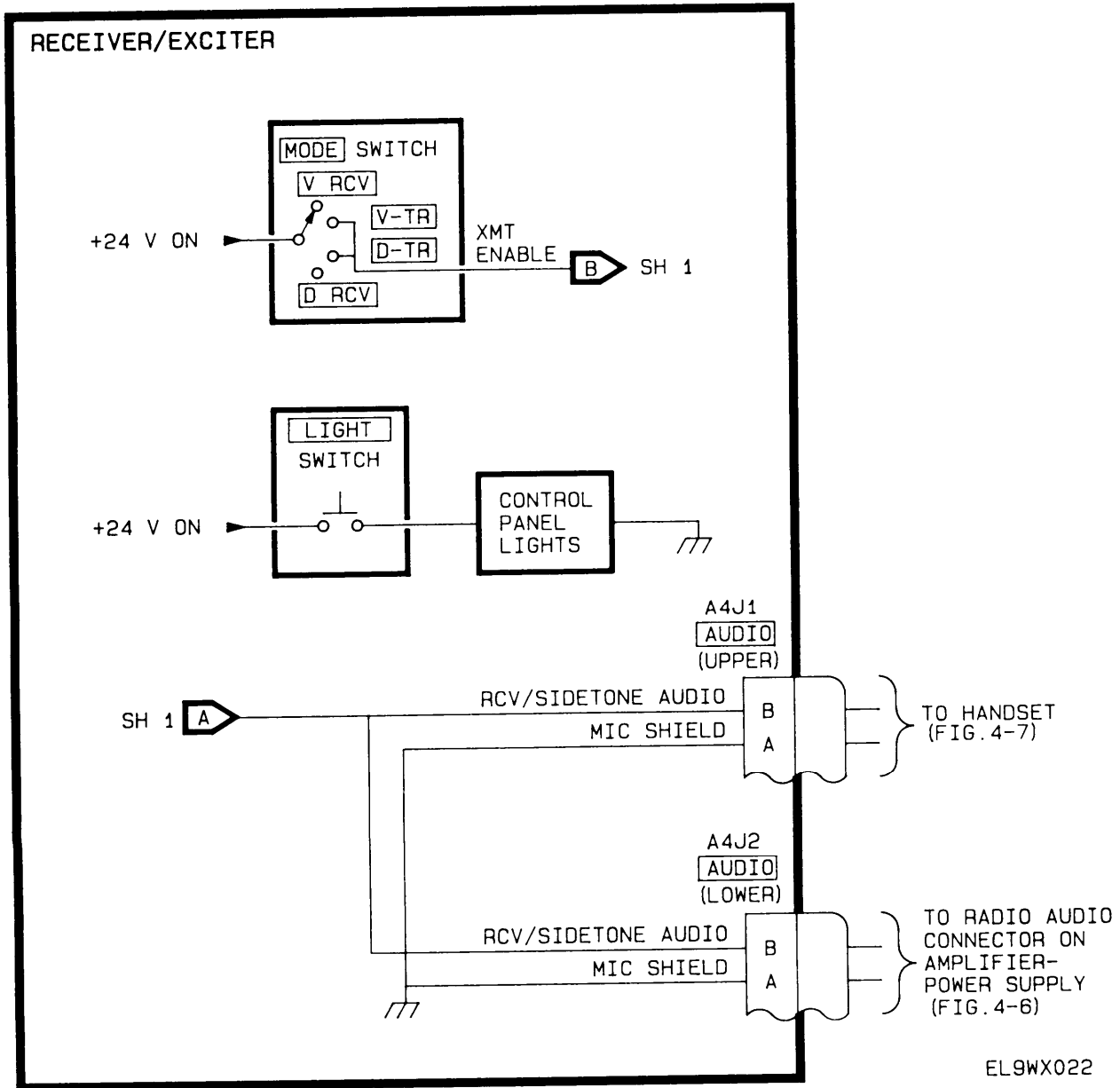

Figure 4-4. Receiver/Exciter Functional Schematic (Sheet 2 of 2)

to a transmit mode (either V-TR or D-T R), then +24 V is applied to the XMT ENABLE signal line. When the XMT ENABLE signal is at +24 V and the PA KEYLINE signal from the modulator/demodulator is low, relay K1 energizes and switches the receiver/exciter to the transmit mode. The modulator/demodulator forces the PA KEY LINE and KEY LINE signals low when the PTT signal from the handset or amplifier-power supply is at ground potential. The keyline signals are also forced low when a CW signal is input from the cw key. The keyline signals are inhibited when a TUNE FAULT signal is present. This prevents transmission when the antenna tuner (part of amplifier/coupler) has failed to tune.

(4) *Tuning Signals.* The TUNE START signal (ground potential) is output to the amplifier/coupler to start the tuning process when the following occurs:

- the AN/G RC-213 is first turned on,
- the settings of the FREQUENCY KHZ switches are changed by more than 0.1 KHZ on the receiver/exciter control panel, or
- the MODE switch (fig. 4-4, sh 2) is set to V-TR or D-TR.

The TUNE IN PROGRESS and TUNE FAULT signals are input to the modulator/demodulator from the amplifier/coupler. From these signals the modulator/demodulator produces audible indicators for the user. These indicators are output to the handset and amplifier-power supply on the RCV/SIDETONE AUDIO signal line. The TUNE FAULT signal also disables the keyline signals to prevent transmission when the antenna tuner (part of amplifier/coupler) has failed to tune.

(5) *Frequency Select Signals.* The FREQUENCY KHZ switches on the control panel set the levels of the six frequency select logic signals (1 MHZ 1, 2, 4, 8 and 10 MHZ 1, 2). These logic signals are sent to the antenna tuner (part of amplifier/coupler) to be used for impedance matching.

(6) *Power.* The power for the receiver/exciter, called + CONDITIONED POWER, is input from the amplifier/coupler and routed through the VOLUME OFF/MAX switch control. The output, +24 V ON, is distributed in the receiver/exciter and routed back to the amplifier/coupler. Also, +24 V ON power drives a power supply in the receiver/exciter. The power supply provides two dc voltages, +6.5 V and +12.5 V. Both voltages are routed within the receiver/exciter, and the 6.5 V power is also output to the amplifier/coupler.

b. *Amplifier/Coupler.* (See fig. 4-5.) Figure 4-5 illustrates the amplifier/coupler signal routing and conditioning. The amplifier/coupler signals are discussed in the following paragraphs.

(1) *Transmit Signals.* The XMT RF signal enters the amplifier/coupler (pin 2) from the receiver/exciter and is routed to the power amplifier. The power amplifier amplifies XMT RF to 20 watts. The amplified XMT RF is routed back to the receiver/exciter harmonic filter and then returned (pin 47) to the amplifier/coupler ANT SEL switch. In normal operation (ANT SEL switch in BNC position), XMT RF is routed through the ANT SEL switch to the antenna tuner for impedance matching. From the antenna tuner, XMT RF is output through the BNC connector to the switching unit (part of installation kit) and then the antenna (vehicular whip, NVIS, or dipole) for transmission. If the antenna tuner cannot match impedance with the antenna used, causing a TUNE FAULT signal, the tuner can be bypassed to provide communication. To do this, the ANT SEL switch is set to the 50  $\Omega$  position and a 50  $\Omega$  antenna is connected to the switching unit. When the ANT SEL switch is in the 50  $\Omega$  position, XMT RF is fed from

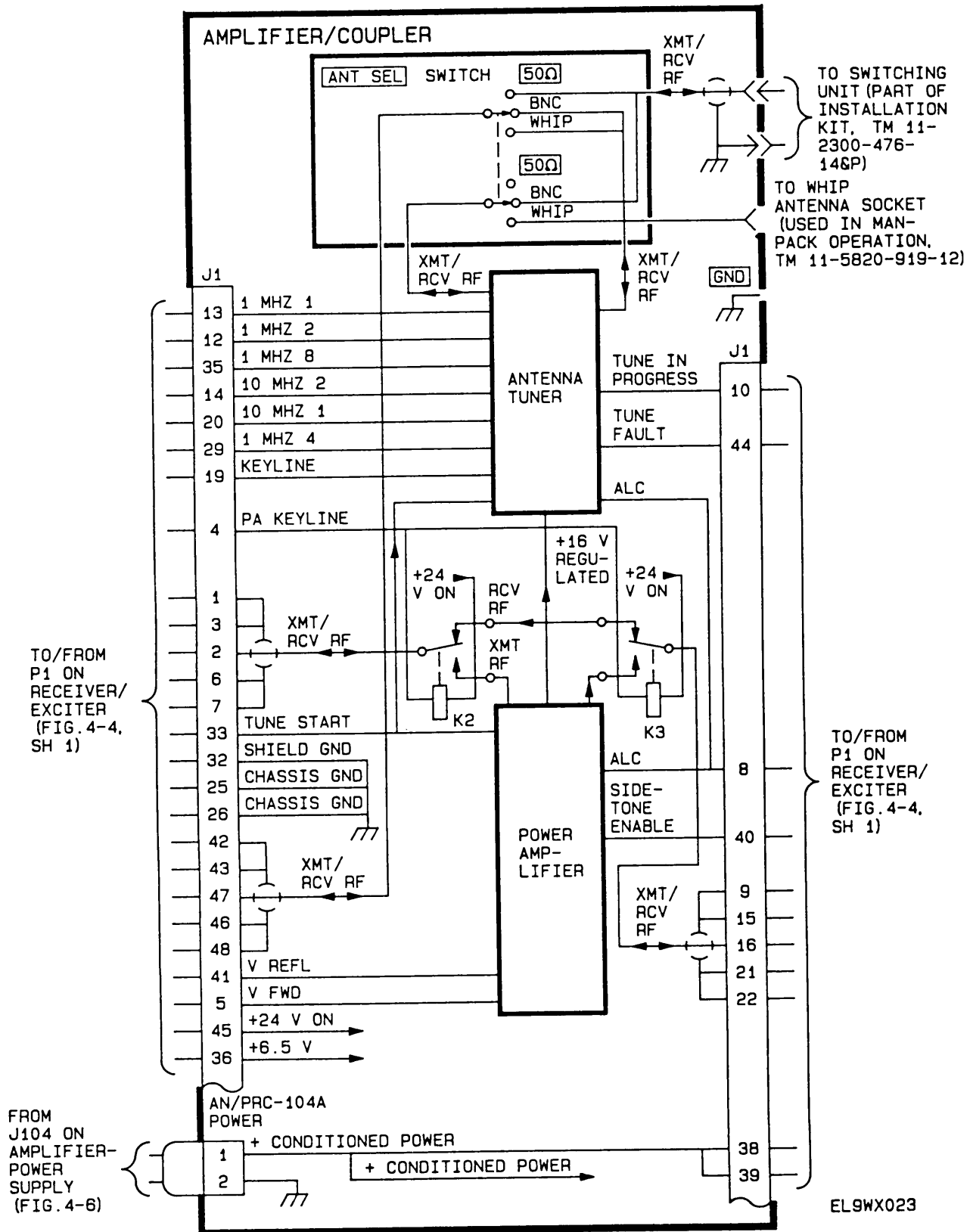

Figure 4-5. Amplifier/Coupler Functional Schematic



the receiver/exciter (pin 47) through the ANT SEL switch directly to the BNC connector for transmission. The ANT SEL switch is only set to the manpack whip antenna setting (far left) when using the AN/PRC-104A in the manpack mode **(TM 11-5820-919-12)**.

V REFL and V FWD voltages are input to the power amplifier. The power amplifier compares each voltage against a reference voltage to determine if output power is adequate (6 watts) to transmit communications. If so, a SIDETONE ENABLE signal is output to the receiver/exciter modulator/demodulator.

V FWD is also compared by the power amplifier to a reference voltage to produce ALC (automatic level control). When V FWD exceeds the reference voltage (radio output exceeds 20 watts), the ALC voltage rises to reduce XMT RF in the modulator/demodulator. During tuning, the antenna tuner samples the radio set output and compares it to a reference voltage. When the output exceeds the reference voltage (radio output exceeds 2 watts), the ALC voltage rises to reduce the level of XMT RF output.

(2) *Receive Signals.* Received signals are input through the BNC connector to the ANT SEL switch as RCV RF. In normal operation (ANT SEL switch in BNC position), RCV RF passes through the antenna tuner and back through the ANT SEL switch prior to being sent to the receiver/exciter harmonic filter. With the ANT SEL switch in the 50  $\Omega$  position (antenna tuner bypassed), RCV RF passes through the ANT SEL switch directly to the receiver/exciter harmonic filter. The harmonic filter removes unwanted noise from RCV RF before it is returned to the amplifier/coupler (pin 16). RCV RF is then routed through the amplifier coupler and output to the receiver/exciter modulator/demodulator.

(3) *Keyline Signals.* KEYLINE and PA KEYLINE (power amplifier keyline) signals are input from the receiver/exciter. These signals determine if the amplifier/coupler operates in the receive or transmit mode. The amplifier/coupler is in the receive mode when the keyline signals are floating. When a low (ground) is input on KEY LINE and PA KEY LINE, relays K2, K3, and circuitry in the antenna tuner are energized placing the amplifier/coupler in the transmit mode.

(4) *Tuning Signals.* When a TUNE START signal is input from the receiver/exciter, the power amplifier produces a +16 V REGULATED signal. The +16 V signal is sent to the antenna tuner to remove all inductors and capacitors from the rf pathway (L-C network reset to zero). The antenna tuner then can use the six frequency select signals input from the receiver/exciter (1 MHz 1, 2, 4, 8 and 10 MHz 1, 2) to match the impedance (adjust the L-C network) of the antenna at the operating frequency. A TUNE IN PROGRESS signal is output by the antenna tuner while impedance matching (L-C) adjustments are made. If the antenna tuner fails to match impedance with the antenna used, it will perform a retune. When the tuning cycle takes too long (over 12 seconds), the antenna tuner will output a TUNE FAULT signal. This means that either the selected antenna is not within the tuning range of the antenna tuner, or the antenna tuner module is faulty. A TUNE FAULT signal is output immediately if the frequency of operation chosen is below 2 MHz. The modulator/demodulator in the receiver/exciter produces audible indicators for the user for TUNE START, TUNE IN PROGRESS, and TUNE FAULT signals.

(5) *Antenna Ground.* The GND terminal on the face of the amplifier/coupler serves as a counterpoise or earth ground for some antennas used in the manpack configuration (TM 11-5820-919-12). This terminal is not normally used in vehicular operation of the AN/GRC-213.

(6) *Power.* The + CONDITIONED POWER signal is input to the amplifier/coupler from the amplifier-power supply. This power is routed throughout the amplifier/coupler and also to the receiver/exciter. The receiver/exciter switches the power and returns +24 V ON to the amplifier/coupler where it is routed internally. The receiver/exciter power supply steps down the power to produce +6.5 V, which is also input to the amplifier/coupler and routed internally.

c. *Amplifier/Power Supply.* (See fig. 4-6.) Amplifier-power supply signal routing and conditioning are illustrated in figure 4-6. A discussion of the signals is contained in the following paragraphs.

(1) *Transmit Signals.* Signals to be transmitted by the AN/GRC-213 are output to the receiver/exciter as XMT AUDIO. XMT AUDIO can be input to the amplifier-power supply from two sources. The first source is direct input from a handset connected to the SPEAKER AUDIO connector. The second source is AMPLIFIED XMT AUDIO from the AN/VIC-1(V). The AMPLIFIED XMT AUDIO signal is emi filtered by emi filter 4 and attenuated by 56 dB to produce the XMT AUDIO signal.

When the AN/GRC-213 transmit power output is adequate for transmission (6 watts), the receiver/exciter produces a SIDETONE AUDIO signal which is input to the amplifier-power supply. SIDETONE AUDIO is amplified by audio amplifier 1, emi filtered, and output to the AN/VIC-1(V) as the UNMUTED AUDIO (para 4-3b) and MONITOR AMP (para 4-3a) signals. With the SQUELCH control on, SIDETONE AUDIO is also squelched by the amplifier-power supply. To do this, the SIDETONE AUDIO signal is compared to a reference signal in the squelch control circuit. If the SIDETONE AUDIO signal is greater than the reference (which is set by the control panel SQUELCH control), then the squelch control circuit closes a switch to remove squelch. This allows SIDETONE AUDIO to pass as SQUELCH AUDIO. SQUELCH AUDIO is output to the handset if one is connected to the SPEAKER AUDIO connector.

(2) *Receive Signals.* When the AN/GRC-213 is in the receive mode, the RCV AUDIO signal is input from the receiver/exciter in the same way the SIDETONE AUDIO signal is input during transmit operation. The RCV AUDIO signal is amplified by audio amplifier 1, emi filtered, and output to the AN/VIC-1(V) as the UNMUTED AUDIO and MONITOR AMP signals. The RCV AUDIO signal is also squelched in the same manner as SIDETONE AUDIO to produce SQUELCH AUDIO. SQUELCH AUDIO is output to the handset if one is connected to the SPEAKER AUDIO connector. SQUELCH AUDIO is also routed through audio amplifier 2 which amplifies the signal to one watt. In the receive mode, the PTT signal line is floating and the amplified SQUELCH AUDIO signal is routed through the contacts of relay K1. (In transmit operation, the PTT signal line drops low, which energizes K1, causing its contacts to open. This disables the SIDETONE AUDIO signal from reaching the loudspeaker.) If the SPEAKER switch is set ON, the amplified signal is applied to the primary of transformer T1. The secondary of T1 supplies impedance matched AMPLIFIED RCV AUDIO to the loudspeaker. When no RCV AUDIO is present and the SQUELCH control is on, a -30 dB noise signal, which is passed by the hi pass filter, will be heard on the loudspeaker. This noise produces a slight hiss to assure the operator that the equipment is operating. If the SQUELCH control is set to OFF, then all RCV AUDIO (and SIDETONE AUDIO) signals are routed as SQUELCH AUDIO.

(3) *PTT Signal.* A PTT (press-to-talk) signal (ground potential) can be input from the AN/VIC-1(V) (4-3a(3) and 4-3b(2)), the receiver/exciter (para 4-4a (3)), or a handset connected to the SPEAKER AUDIO connector. The PTT signal being at ground potential energizes relays K1 and K2, which disables the RETRANSMIT signal to the AN/VIC-1(V) and the AMPLIFIED RCV AUDIO signal to the loudspeaker. The disabled RETRANSMIT signal prevents vhf retransmission and the disabled AMPLIFIED RCV AUDIO signal silences the loudspeaker during transmission. The PTT signal is also used in the receiver/exciter to put the AN/PRC-104A in the transmit mode.



(4) *Retransmit Signal.* The RETRANSMIT signal is controlled by the squelch control circuit and the PTT signal. When the RCV AUDIO signal is strong enough to surpass the reference signal set by the SQUELCH control circuit and the PTT signal is floating, the RETRANSMIT signal is at ground potential. This RETRANSMIT signal is output to the AN/VIC-1(V) for retransmit operation (para 4-3b).

(5) *AN/PRC-104A Ground.* SPEAKER RTN/MIC SHIELD (AN/PRC-104A ground) provides a direct return path for the loudspeaker. This line also is the return path, at the audio filter, for the PTT and XMT AUDIO signals. In addition, it is the shield for the RCV/SIDETONE AUDIO signals. The returns and shielding help reduce rfi (radio frequency interference) and transients in the signal lines.

(6) *Power.* The vehicle power generating system supplies the power for the amplifier-power supply. This positive dc voltage, called + BATTERY, is emi filtered by emi filters 1 and 2 in the amplifier-power supply and routed to a parallel radio set and the AN/VIC-1(V) as + BATTERY (EXT PWR). The input power is also routed through the POWER circuit breaker to the power conditioner circuit. The + BATTERY input is conditioned to produce + CONDITIONED POWER. The conditioning protects the power voltage from transients, overload, overvoltage, and reverse polarity. The + CONDITIONED POWER turns on the POWER switchlight, is routed internally, and is input to a power supply that produces +12 V and +6.9 V. These voltages are routed internally. The + CONDITIONED POWER is also emi filtered by emi filter 3 and sent to the amplifier/coupler.

d. *Handset.* (See fig. 4-7.) Figure 4-7 illustrates the input and output signals of the handset. The following paragraphs describe these signals.

(1) *Transmit Signals.* Signals to be transmitted are generated from the handset mouthpiece and are output as XMT AUDIO. The XMT AUDIO signal is sent to the receiver/exciter either directly or through the amplifier-power supply. This signal is modulated, amplified, and transmitted by the receiver/exciter and amplifier/coupler. A sidetone signal is routed to the handset as SIDETONE AUDIO (handset connected to receiver/exciter) or SQUELCH AUDIO (handset connected to the amplifier-power supply). This SIDETONE AUDIO signal is applied to the handset earpiece which produces audible sounds to indicate to the operator that power output is adequate for transmission.

(2) *Receive Signals.* Received signals are input to the handset as RCV AUDIO (handset connected to receiver/exciter) or SQUELCH AUDIO (handset connected to amplifier-power supply). The receive signal is applied to the handset earpiece which produces the audible sounds for the operator.

(3) *PTT Signal.* The PTT signal is output at ground potential to either the receiver/exciter (handset connected to receiver/exciter) or the amplifier-power supply (handset connected to amplifier-power supply) when the PTT switch on the handset is pressed. This ground potential (low) PTT signal is routed within the AN/GRC-213 to place it in the transmit mode.

(4) *Return.* The MIC SHIELD return (4) provides the return path for the RCV, SIDETONE, and SQUELCH AUDIO signals.

e. *Loudspeaker.* (See fig. 4-7.) As illustrated in figure 4-7, AMPLIFIED RCV AUDIO is input to the loudspeaker and applied to the 600  $\Omega$  primary of internal transformer T2. The 8  $\Omega$  secondary of T2 provides the correct impedance for the speaker. The AMPLIFIED RCV AUDIO signal is converted by the speaker to audible tones for the user. SPEAKER RTN provides the signal return path for AMPLIFIED RCV AUDIO on the primary of T2.

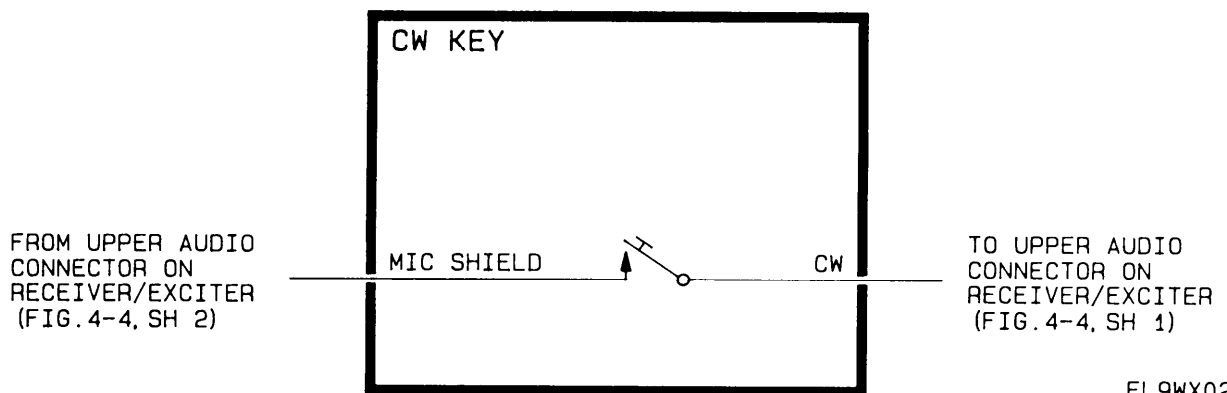
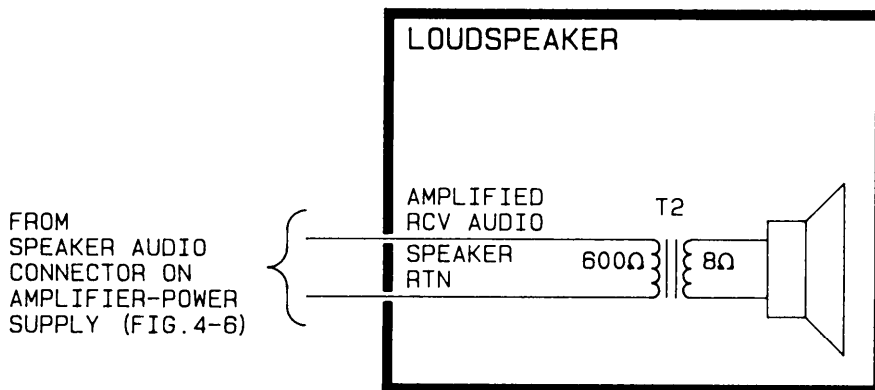
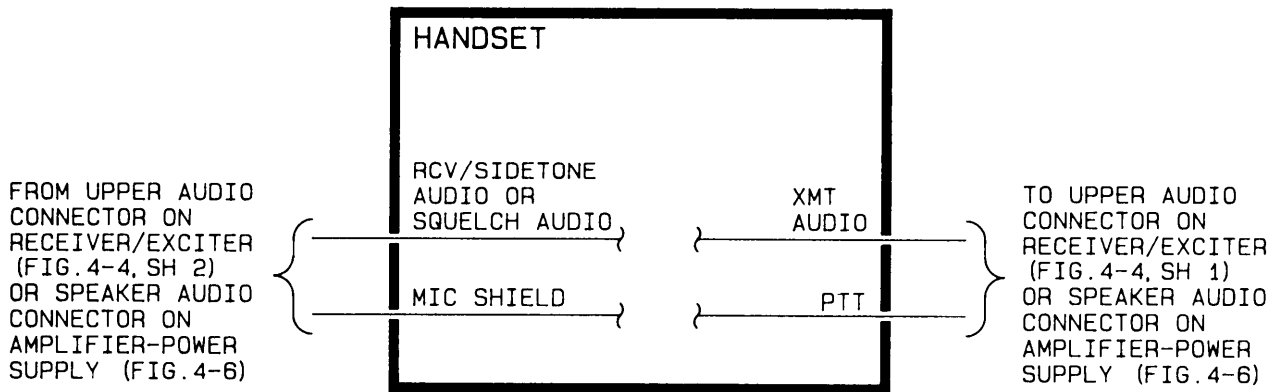

EL9WX025

Figure 4-7. Handset, Loudspeaker, and CW Key Functional Schematics

f. CW Key. (See fig. 4-7.) Figure 4-7 illustrates how the CW (telegraph) signal is produced by the cw key. When the cw key impressed, the CW signal line is connected to MIC SHIELD (AN/PRC-104A ground). This forces the CW signal line to ground potential which is output to the receiver/exciter. The receiver/exciter modulates it to a 1-kHz tone to develop the signal that is transmitted by the amplifier/coupler.

## CHAPTER 5 OPERATOR MAINTENANCE

### Section 1. OPERATOR PREVENTIVE MAINTENANCE, CHECKS, AND SERVICES

**5-1. General.** Operator level preventive maintenance, checks and services (PMCS) consists of inspection and testing of the AN/GRC-213 and its installation kit. This maintenance is done to prevent equipment failure, reduce down time, and assure that the equipment is serviceable. On a daily basis, the operator is to perform both a visual inspection and minimum performance test. On a weekly basis, the operator is to inspect the battery pack with internal connectors for corrosion. The procedures for visual inspection, battery pack inspection, and the minimum performance test are contained in the following paragraphs.

**5-2. Daily Visual Inspection.** Perform the daily visual inspection as follows:

a. Verify that POWER circuit breaker on amplifier-power supply is set to OFF. If not, set circuit breaker to OFF.

b. Visually inspect the following cables for cracks in the outer insulation: rf, AN/PRC/104A power, audio, dipole rf, NVIS rf, handset, loudspeaker, cw key, power, and antenna. (Power and antenna cables are part of the installation kit.) If the insulation on any cable is cracked, notify organizational maintenance.

c. Visually inspect the connectors on each cable to verify that they are not loose or damaged. If any connector is loose or damaged, notify organizational maintenance.

d. Visually inspect the switching unit, vehicular whip antenna, electrical equipment mount, and all equipment listed in table 1-2 for cracks, dents, or holes. If any equipment is cracked, dented, or punctured, notify organizational maintenance.

e. Inspect the receiver/exciter, amplifier/coupler, amplifier-power supply, and switching unit for broken knobs. If any knobs are broken, notify organizational maintenance.

f. Inspect the electrical equipment mount and mounting brackets for loose nuts and bolts. If any nuts and bolts are loose, notify organizational maintenance.

g. Inspect welds of brackets (part of installation kit), that secure electrical equipment mount in vehicle, for cracks. If any bracket welds are cracked, notify organizational maintenance.

h. Inspect each dipole reel assembly for improper operation. If either reel assembly is not operating properly, notify organizational maintenance.

i. Inspect dipole tape measure for improper operation or an unreadable scale. If tape measure is not readable or not operating properly, notify organizational maintenance.

j. Inspect canvas bags (dipole, NVIS, and field pack) for cuts or tears. If any of the canvas bags is cut or torn, notify organizational maintenance.

**5-3. Daily Minimum Performance Test.** Perform the daily Minimum Performance Test procedures in accordance with paragraph 6-8.

**5-4. Weekly Battery Pack Inspection.** Perform the weekly visual inspection and corrosion control instructions for the manpack battery pack as outlined below. Never charge lithium batteries. For instructions on charging batteries and applicable warnings, refer to the maintenance instructions in TM 11-5820-919-12.

a. Unfasten lower set of latches on either end of battery case and remove battery case top (fig. 5-1).

b. Visually inspect battery connectors (fig. 5-1) in battery case top for corrosion. If the connectors are corroded, proceed as follows:

(1) Remove Corrosion from Connectors with brush (item 1, Appx E) or cloth (item 3, Appx E).

(2) Clean connector with clean cloth (item 3, Appx E). If connector is damaged, notify organizational maintenance.

Replace battery case top onto bottom half and fasten lower set of latches on either end of battery case (fig. 5-1).



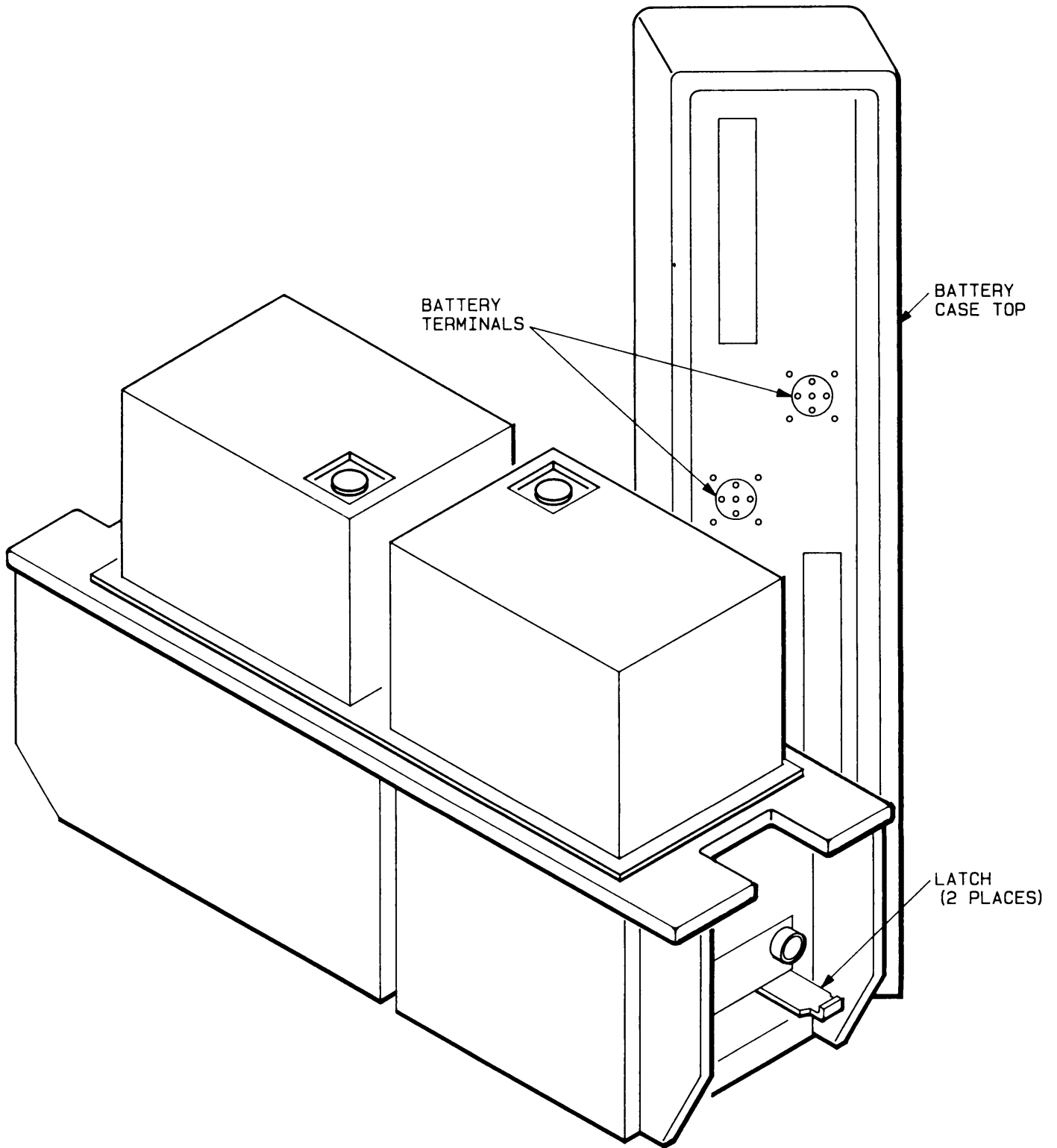

EL9WX026

Figure 5-1. Battery Pack Inspection

## Section II. OPERATOR MAINTENANCE

**5-5. General.** Operator maintenance consists of performing as necessary, cleaning and corrosion control procedures for the AN/GRC-213 and its installation kit. These procedures are contained in the following paragraph.

**5-6. Cleaning and Corrosion Control Instructions.** Clean and control corrosion on the AN/GRC-213 and its installation kit as follows:

- a. For vehicles MS77A1, M882, and M113A1, set vehicle master power switch to off position.

**CAUTION**

Sparks may damage power cable or connector J101 (25, fig. 5-2) if POWER circuit breaker on amplifier-power supply is not properly set to OFF in following steps.

- b. Verify POWER circuit breaker (11, fig. 5-2) on amplifier-power supply (12, fig. 5-2) is set to OFF. If necessary, set to OFF.
- c. Remove all dirt, dust, grease, or other debris from AN/GRC-213 and installation kit: with a cloth (item 3, Appx E) or brush (item 1, Appx E), and cleaning compound (item 4, Appx E) or soap (item 5, Appx E) and water.

**CAUTION**

Avoid water contact with the handset and any other items that may be damaged.

- d. Rinse all equipment with a clean cloth (item 3, Appx E) moistened in clear water.
- e. Remove all cables and accessories as outlined below:
  - (1) Disconnect handset or cw key from upper AUDIO connector (2, fig. 5-2) on receiver/exciter (3, fig. 5-2).
  - (2) Disconnect audio cable from lower AUDIO connector (1, fig. 5-2) on receiver/exciter (3, fig. 5-2) and RADIO AUDIO connector (14, fig. 5-2) on amplifier-power supply (12, fig. 5-2).
  - (3) Disconnect loudspeaker from SPEAKER AUDIO connector (15, fig. 5-2) on amplifier-power supply (12, fig. 5-2).
  - (4) Disconnect rf cable from BNC connector (5, fig. 5-2) on amplifier/coupler (4, fig. 5-2) and RADIO-RF connector J201 (7, fig. 5-2) on switching unit (6, fig. 5-2).

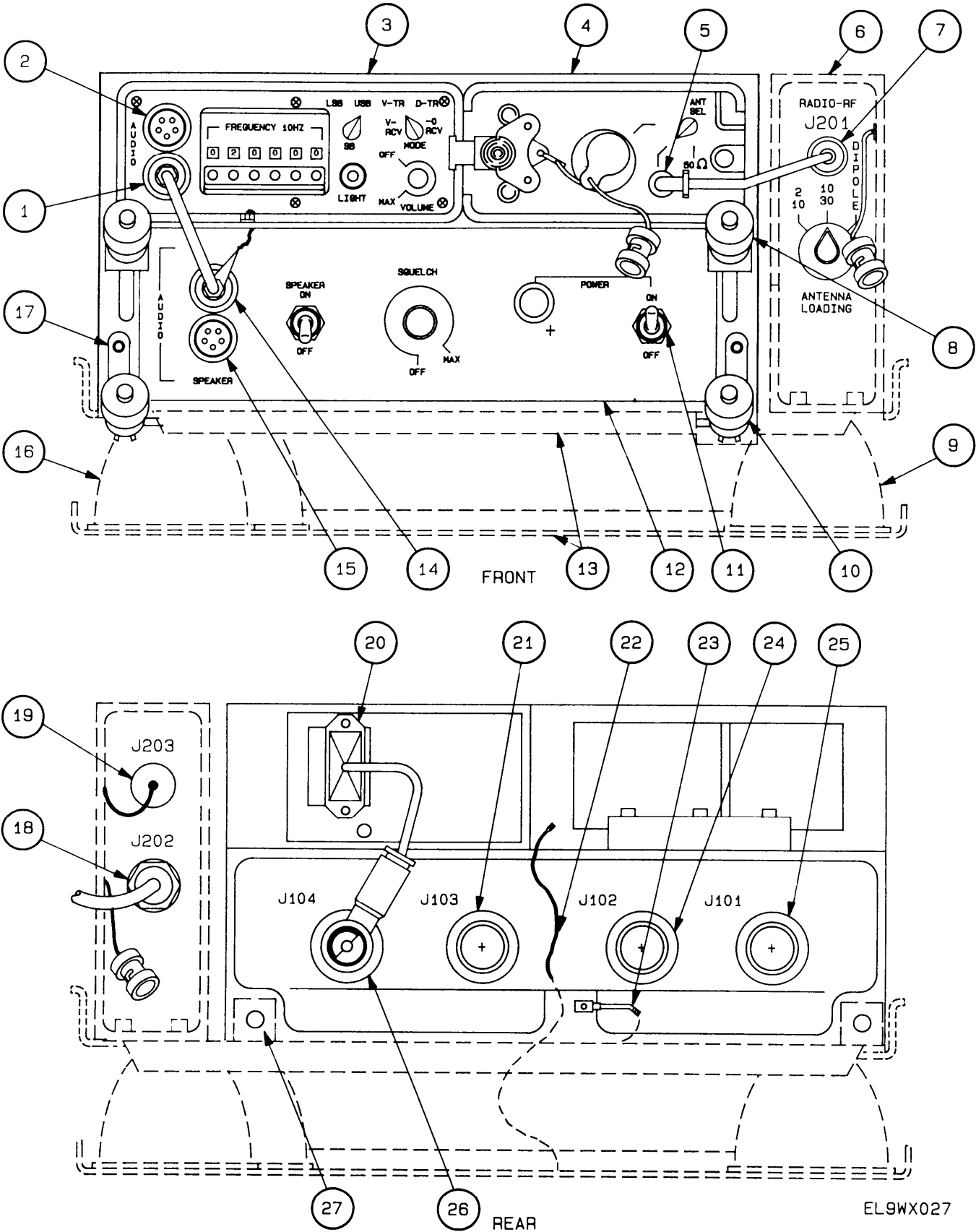

Figure 5-2. Controls and Connectors for Cleaning and Corrosion Control

- (5) Disconnect AN/PRC-104 power cable from connector J104 (26, fig. 5-2) on rear of amplifier-power supply (12, fig. 5-2) and AN/PRC-104 power input connector (20, fig. 5-2) on rear of amplifier/coupler (4, fig. 5-2).
  - (6) Disconnect power cable from connector J101 (25, fig. 5-2) located on rear of amplifier-power supply (12, fig. 5-2).
  - (7) If AN/VIC-1(V) is used, disconnect intercommunication cable from connector J102 (24, fig. 5-2) on rear of amplifier-power supply (12, fig. 5-2).
  - (8) If parallel radio set is used, disconnect its power cable from connector J103 (21, fig. 5-2) on rear of amplifier-power supply (12, fig. 5-2).
  - (9) Disconnect vehicular whip antenna cable (part of installation kit) from connector J202 (18, fig. 5-2) and dipole rf or NVIS rf cable (if used) from connector J203 (19, fig. 5-2) on rear of switching unit (6, fig. 5-2) (part of installation kit).
- f. Visually inspect each connector for bent, recessed, or missing pins. If any pins are bent, recessed, or missing, notify organizational maintenance.
- g. Visually inspect the rubber seal on each connector to verify that it is not out of place or damaged. If any rubber seals are out of place, adjust them to the correct position. If any rubber seals are damaged, notify organizational maintenance.
- h. Separate the AN/GRC-213 and installation kit units as outlined below.
- (1) Disconnect quick-release ground connectors (22 and 23, fig. 5-2), located on rear of amplifier-power supply (12, fig. 5-2), from mounting base (13, fig. 5-2).
  - (2) Pull out, loosen, and disengage fasteners (10, fig. 5-2) from hooks (17, fig. 5-2) located on front of amplifier-power supply (12, fig. 5-2).
  - (3) Slide amplifier-power supply (12, fig. 5-2) forward until it clears the guide pin assemblies (27, fig. 5-2) and lift amplifier-power supply with latched receiver/exciter (3, fig. 5-2) and amplifier/coupler (4, fig. 5-2) free of mounting base (13, fig. 5-2).
  - (4) Pull out and loosen fasteners (8, fig. 5-2) from hooks located on front of receiver/exciter (3, fig. 5-2) and amplifier/coupler (4, fig. 5-2) until fasteners can be disengaged from hooks.
  - (5) Slide latched receiver/exciter (3, fig. 5-2) and amplifier/coupler (4, fig. 5-2) units forward to disengage retaining cleats and lift from amplifier-power supply (12, fig. 5-2).
  - (6) Lay latched receiver/exciter (3, fig. 5-2) and amplifier/coupler (4, fig. 5-2) on a flat surface and unfasten front and rear latches, respectively, securing the receiver/exciter and amplifier/coupler together.
  - (7) Carefully separate receiver/exciter (3, fig. 5-2) and amplifier/coupler (4, fig. 5-2).

- i. Visually inspect AN/GRC-213 units, mounting base, and switching unit for dents, cracks, holes, or missing items. If any equipment is dented, cracked, missing, or punctured, notify organizational maintenance.
- j. Visually inspect the AN/GRC-213 units, mounting base, and switching unit for bare metal or corrosion. If any equipment is corroded or has exposed metal, complete the needed substeps below.
  - (1) Locate all areas of exposed bare metal on the exterior of AN/GRC-213 or installation kit equipment.
  - (2) Use masking tape (item 10, Appx E) to cover all areas or items (lens covers, connectors, knobs, and switches) that do not warrant painting.
  - (3) Prepare the surface(s) to be painted by sanding each with sandpaper (item 9, Appx E).
  - (4) Wipe each surface after sanding with a cloth (item 3, Appx E) to remove dust caused by sanding.
  - (5) Use paint brush (item 2, Appx E) to apply primer [item 8, Appx E) to cover exposed bare metal. Let primer dry completely.
  - (6) Use paint brush (item 2, Appx E) to apply epoxy paint (item 7, Appx E) to cover primer and let dry completely.
  - (7) Use paint brush (item 2, Appx E) to apply semigloss enamel paint (item 6, Appx E) where necessary to panel markings and let dry completely.
  - (8) Remove all masking tape.

**WARNING**

When using a compressed airjet, use eyeshields to prevent severe eye injury.

**CAUTION**

Compressed air must be clean, dry, and at a maximum pressure of 28 psi. Do not overlook the force of the airjet when cleaning delicate parts.

- k. Dry components and remove water from inside of each connector with an air jet (if available) or dry cloth (item 3, Appx E).
- l. Inspect the mounting base (13, fig. 5-2) shock mounts (9 and 16, fig. 5-2) for wear by moving mount and looking for excessive free play. If shock mounts are worn, notify organizational maintenance.
- m. Install AN/GRC-213 units back on mounting base as outlined below.
  - (1) Secure amplifier/coupler (4, fig. 5-2) to receiver/exciter (3, fig. 5-2) and fasten latches.

- (2) Place latched receiver/exciter (3, fig. 5-2) and amplifier/coupler (4, fig. 5-2) on top of amplifier/power supply (12, fig. 5-2).
- (3) Slide latched units toward rear of amplifier-power supply (12, fig. 5-2) until receiver/exciter (3, fig. 5-2) and amplifier/coupler (4, fig. 5-2) fully engage retaining cleats on amplifier-power supply (12, fig. 5-2).
- (4) Tighten fasteners (8, fig. 5-2) overbooks located on front of receiver/exciter (3, fig. 5-2) and amplifier/coupler (4, fig. 5-2) until both units are securely attached to top of amplifier-power supply (12, fig. 5-2).
- (5) Slide amplifier-power supply (12, fig. 5-2) with latched receiver/exciter (3, fig. 5-2) and amplifier/coupler (4, fig. 5-2) onto mounting base (13, fig. 5-2). Rear of amplifier-power supply will be toward rear of mounting base. Slide amplifier-power supply straight back until it is fully seated against guide pin assembly (27, fig. 5-2) located on mounting base.
- (6) Tighten fasteners (10, fig. 5-2) over hooks (17, fig. 5-2) until amplifier-power supply (12, fig. 5-2) is securely attached to mounting base (13, fig. 5-2).
- (7) Connect quick-release ground connectors (22 and 23, fig. 5-2), located on rear of amplifier-power supply (12, fig. 5-2) and receiver/exciter (3, fig. 5-2), to mounting base (13, fig. 5-2).
- (8) Connect vehicular whip antenna cable to connector J202 (18, fig. 5-2) and dipole rf or NVIS rf cable (if used) to connector J203 (19, fig. 5-2) on rear of switching unit (6, fig. 5-2).
- (9) If parallel radio set is to be used, connect its power cable to connector J103 (21, fig. 5-2) on rear of amplifier-power supply (12, fig. 5-2).
- (10) If AN/VIC-1(V) is to be used, connect intercommunication cable to connector J102 (24, fig. 5-2) on rear of amplifier-power supply (12, fig. 5-2).
- (11) Connect power cable to connector J101 (25, fig. 5-2) located on rear of amplifier-power supply (12, fig. 5-2).
- (12) Connect AN/PRC-104A power cable to connector J104 (26, fig. 5-2) on rear of amplifier-power supply (12, fig. 5-2) and AN/PRC-104A power input connector (20, fig. 5-2) on rear of amplifier/coupler (4, fig. 5-2).
- (13) Connect rf cable to BNC connector (5, fig. 5-2) on amplifier/coupler (4, fig. 5-2) and RADIO-RF connector J201 (7, fig. 5-2) switching unit (6, fig. 5-2).
- (14) Connect audio cable (chained to front of amplifier-power supply) to lower AUDIO connector (1, fig. 5-2) on receiver/exciter (3, fig. 5-2) and to RADIO AUDIO connector (14, fig. 5-2) on amplifier power supply (12, fig. 5-2).
- (15) Connect handset or cw key to upper AUDIO connector (2, fig. 5-2) on receiver/exciter (3, fig. 5-2).
- (16) Connect loudspeaker to SPEAKER AUDIO connector (15, fig. 5-2) on amplifier-power supply (12, fig. 5-2).

## CHAPTER 6

### ORGANIZATIONAL MAINTENANCE

#### Section 1. ORGANIZATIONAL PREVENTIVE MAINTENANCE, CHECKS, AND SERVICES

**6-1. General.** Preventive maintenance is systematic care, inspection, and servicing of equipment to maintain it in serviceable condition, prevent breakdown, and assure maximum operational capability. Organizational preventive maintenance checks and services (PMCS) is conducted on a quarterly basis.

a. Organizational PMCS will be scheduled using prescribed forms specified in DA Pam 738-750.

b. Cleaning, dusting, washing; stowing of components not in use; checking damaged cables; tightening all nuts and bolts holding the equipment and cables to the vehicle, and covering unused receptacles with dust covers not listed among the PMCS procedures. These things are taken care of as soon as the need is seen.

c. The PMCS procedures in paragraph 6-2 cover the radio sets and also the components required to make the radio sets operational. In tracked vehicles, these include the audio accessories and the vehicle electrical harness consisting of Mount, MT-6242, cables and mounting hardware. In wheeled vehicles, these include the audio accessories, MT-6242, cables and mounting hardware.

#### **6-2. Organizational Preventive Maintenance Checks and Services - Quarterly Schedule.**

#### NOTES

- The ITEM NO. column in the following chart shall be used as source of item numbers for the TM NUMBER column on DA Form 2404 (Equipment Inspection and Maintenance Worksheet) in recording results of PMCS.
- If the equipment fails to operate or the equipment does not meet the criteria specified in the PROCEDURES column in the chart, report the failure in accordance with the procedures specified in DA Pam 738-750.
- Select those items to be inspected that are authorized for the installation in which the radio is installed.

**PREVENTIVE MAINTENANCE CHECKS AND SERVICES (PMCS)**

**M - MONTHLY**

**Q - QUARTERLY**

ITEM NO.	INTERVAL		ITEM TO BE INSPECTED	PROCEDURE
	M	Q		
1		•	Completeness	All components required to make the radio are on hand (Appx A) or available.
2		•	Metal surfaces	Remove rust, corrosion, and fungus. Spot paint bare metal spots.
3		•	Audio accessory	Apply a thin coating of silicone grease to the cable connector O-ring (not to the connector contacts).
4		•	Antenna	a. The mounting bolts are to be snug tight. b. separate the antenna elements, clean the threads of the top section, and apply a thin coating of silicone grease to the threads.
5		•	Amplifier power	The power indicator socket and lens cap are not loose, and can be rotated clockwise and counter-clockwise.
6		•	MT-6234/GRC	a. Check the condition of the mounts (shock absorbers) by grasping the top tray of the MT-6234 and exerting sufficient force in different positions (up and down, side to side, back and forth) to disclose any excessive wear or damaged resilient mounts.  b. Check the condition of the shock absorbers by pulling the amplifier power supply out about 5 inches and quickly pushing it back into the mounting.  c. The bonding strap is secured to the top tray and the bottom plate.  d. Check for damaged or missing clamps and guide pins.  e. Clean out the drain holes next to the mounting screws.
7		•	RT-1209/URC	a. The clamps are not damaged and they hold the radio case.  b. Observe the case of the unit to see if there is evidence of bulging (due possibly to gas exploding in the case).  c. Check the front-panel connections.



PREVENTIVE MAINTENANCE CHECKS AND SERVICES (PMCS)-Continued

M - MONTHLY

Q - QUARTERLY

ITEM NO.	INTERVAL		ITEM TO BE INSPECTED	PROCEDURE
	M	Q		
				<p>d. Clean out the receptacle in the antenna mount. Also, clean out the drain hole near the base of this antenna mount leading to the threaded antenna receptacle. Loosen the front panel captive screws, separate the front panel and chassis from the case, and perform the following checks:</p> <p>Inspect the battery connector for the following:</p> <ul style="list-style-type: none"> <li>(1) A rubber gasket (shaped similar to the metal ring around the battery connector hole RT-1209/URC case) must be installed on the radio connector. it must be undamaged, be seated flush with the bottom of the connector (inside the four connector mounting screws), and flush with the body of the connector.</li> <li>(2) The O-rings on the radio connector must be installed and undamaged (that is, they must not be sheared) and must be seated, under tension, in their grooves.</li> <li>(3) The radio connector pins are not bent or loose, or otherwise damaged.</li> </ul>

## Section II. ORGANIZATIONAL MAINTENANCE

**6-3. General.** Organizational level maintenance starts with isolating a fault within the AN/GRC-213 to a replaceable unit. The faulty unit is then replaced and the minimum performance test is run to verify proper operation of the AN/GRC-213. Fault isolation, replacement procedures, and the minimum performance test are contained in the following paragraphs, along with the tools, equipment, materials, and parts needed for repair.

**6-4. Common Tools and Equipment.** For authorized common tools and equipment, refer to the Modified Table of Organization and Equipment (MTOE) applicable to your unit.

**6-5. Special Tools, TMDE, and Support Equipment.** Refer to the repair parts and special tools list, TM 11-5820-923-20P, covering organizational maintenance for the AN/GRC-213. Also, refer to the Maintenance Allocation Chart in appendix B.

**6-6. Materials.** Materials required for organizational maintenance are listed in appendix E, Expendable/Durable Supplies and Materials List.

**6-7. Repair Parts.** Repair parts are listed and illustrated in the repair parts and special tools list, TM 11-5820-923-20P, covering organizational maintenance for the AN/GRC-213.

**6-8. Fault Isolation.** Fault isolation is performed with the AN/GRC-213 mounted on an installation kit in the vehicle. The general fault isolation test setup in the vehicle is shown in figure 6-1. For detailed setup instructions, refer to paragraph 2-2, Mounting, and paragraph 2-3, Interconnections. Distinct audible tones produced by the AN/GRC-213, along with measurements taken with a voltmeter and rf wattmeter, will aid you in isolating to the faulty unit. The fault isolation test is followed by replacement instructions for each part of the AN/GRC-213. Upon replacing a unit, the Minimum Performance Test in paragraph 6-10 should be run to verify proper operation of the AN/GRC-213. The fault isolation flowchart is contained in figure 6-2.

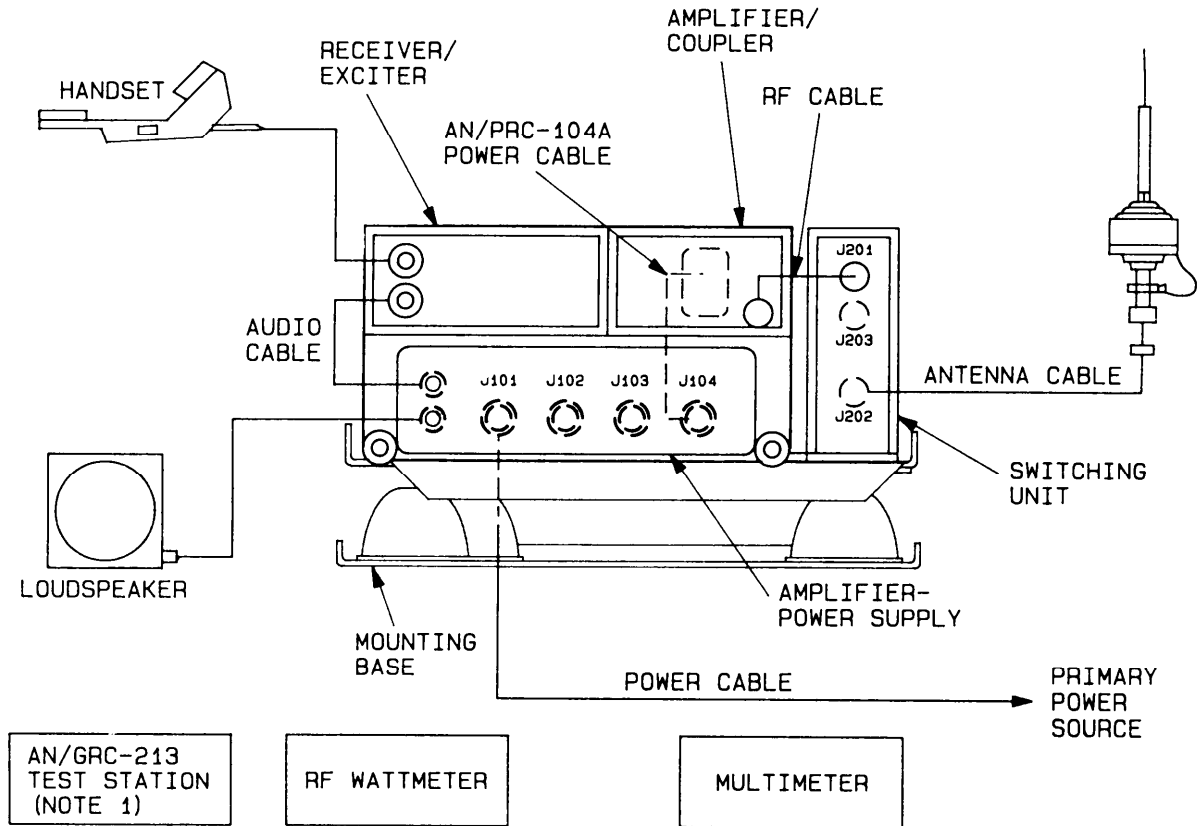

NOTE:

TEST STATION SHOULD BE WITHIN 50 METERS OF UNIT UNDERVEST AND SET TO THE SAME FREQUENCY (03000.0 KHZ OR OTHER AUTHORIZED FREQUENCY).

EL9WX028

Figure 6-1. Fault Isolation Test Setup

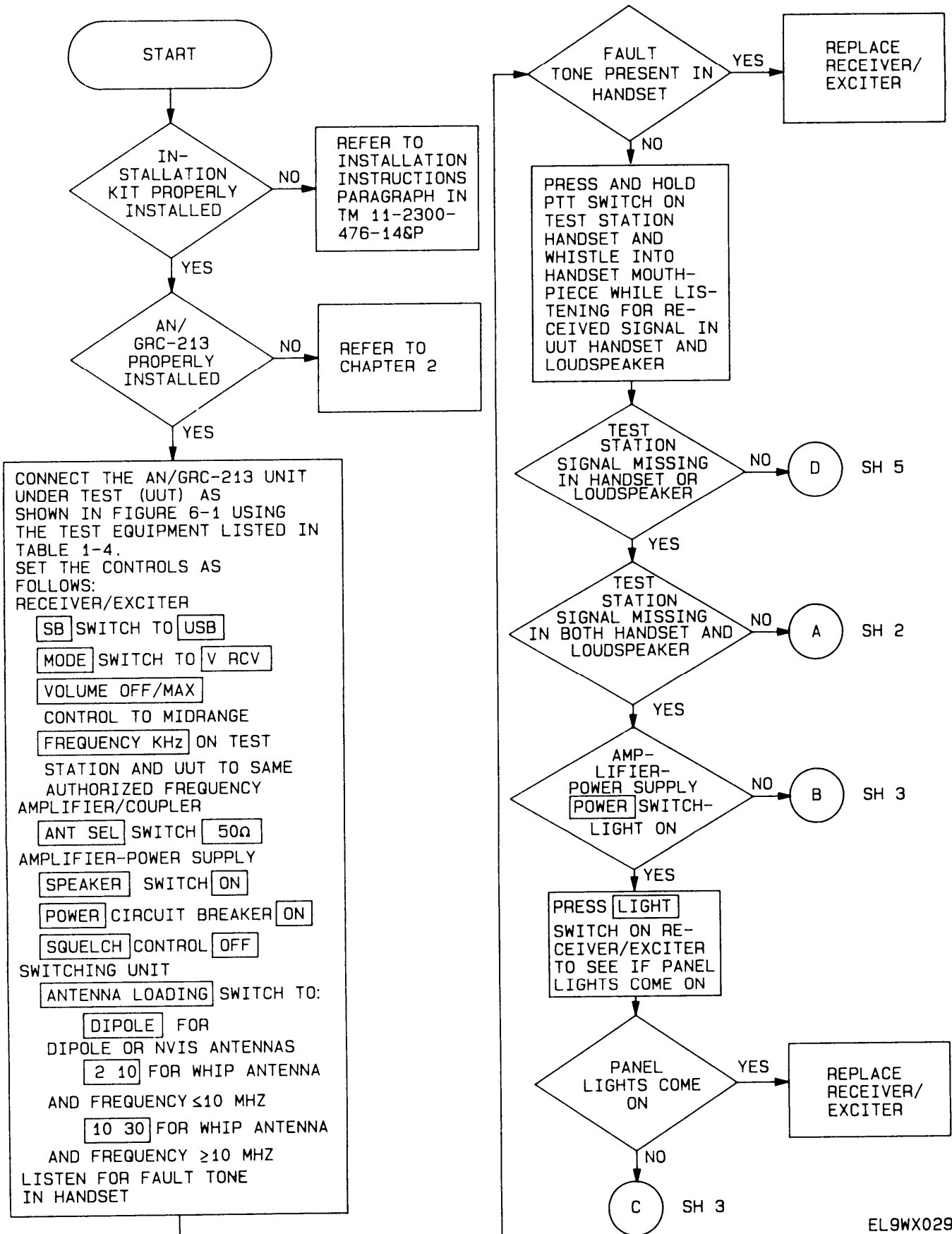

EL9WX029

Figure 6-2. Fault Isolation Flowchart (Sheet 1 of 14)

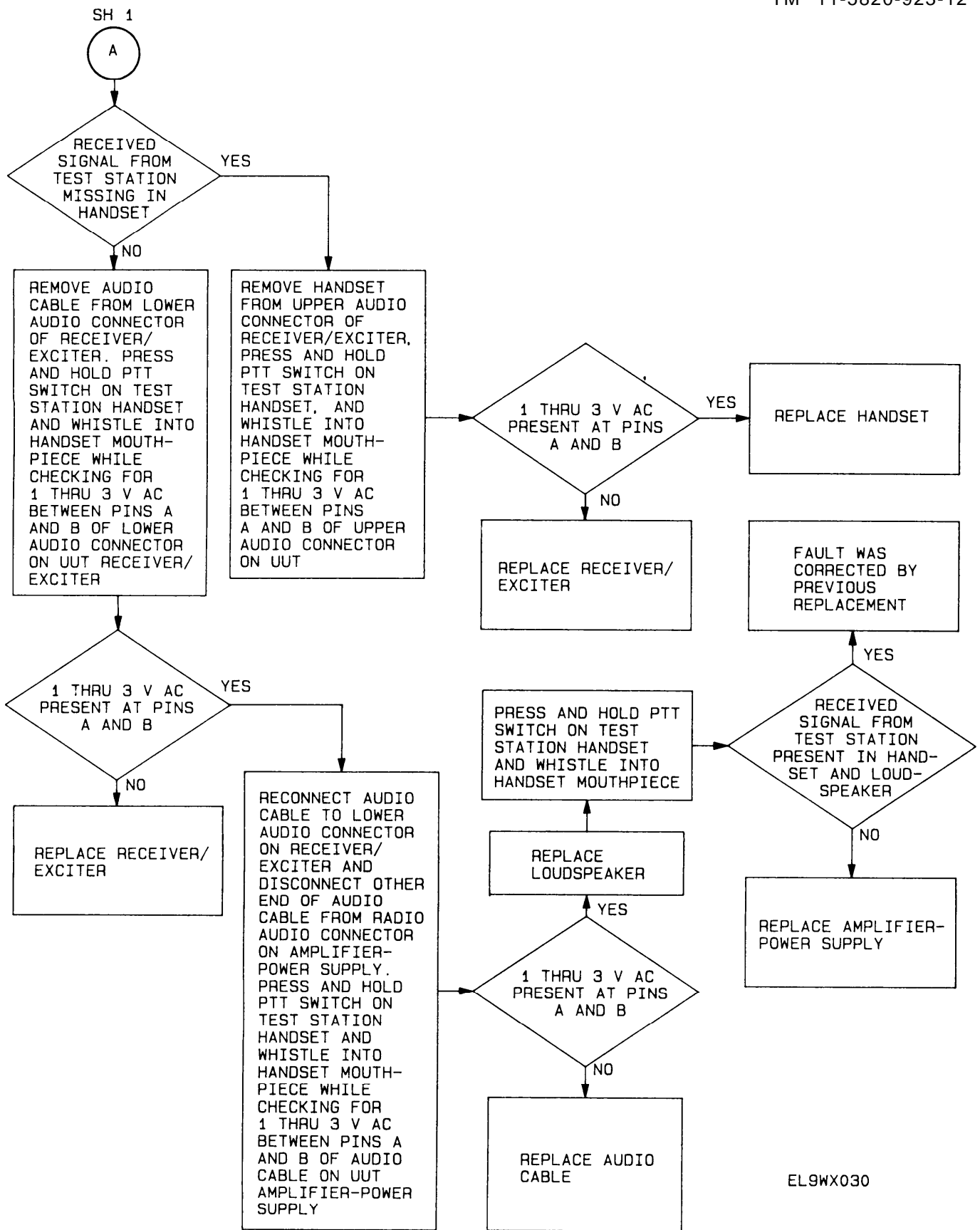

EL9WX030

Figure 6-2. Fault Isolation Flowchart (Sheet 2 of 14)

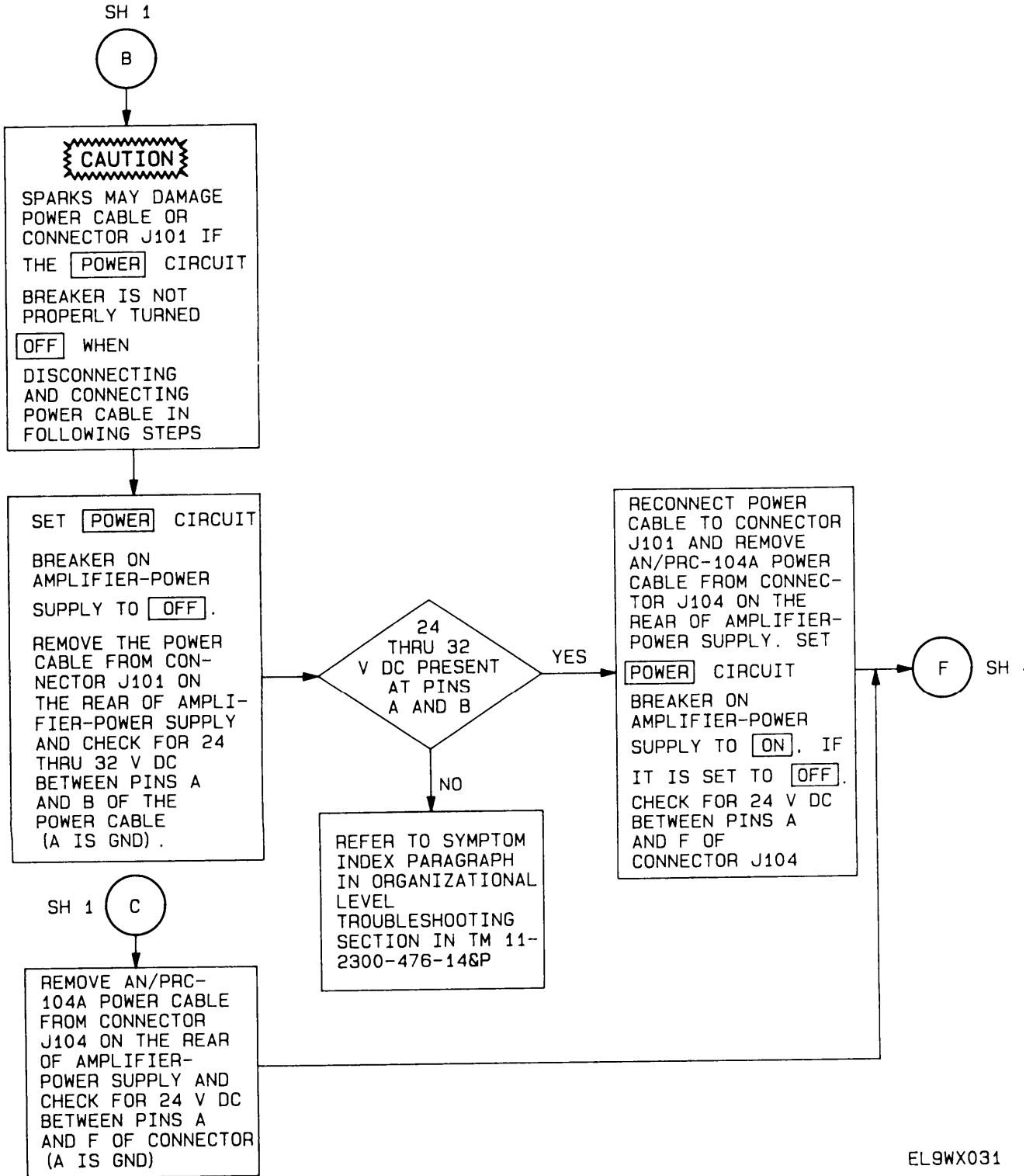

EL9WX031

Figure 6-2. Fault Isolation Flowchart (Sheet 3 of 14)

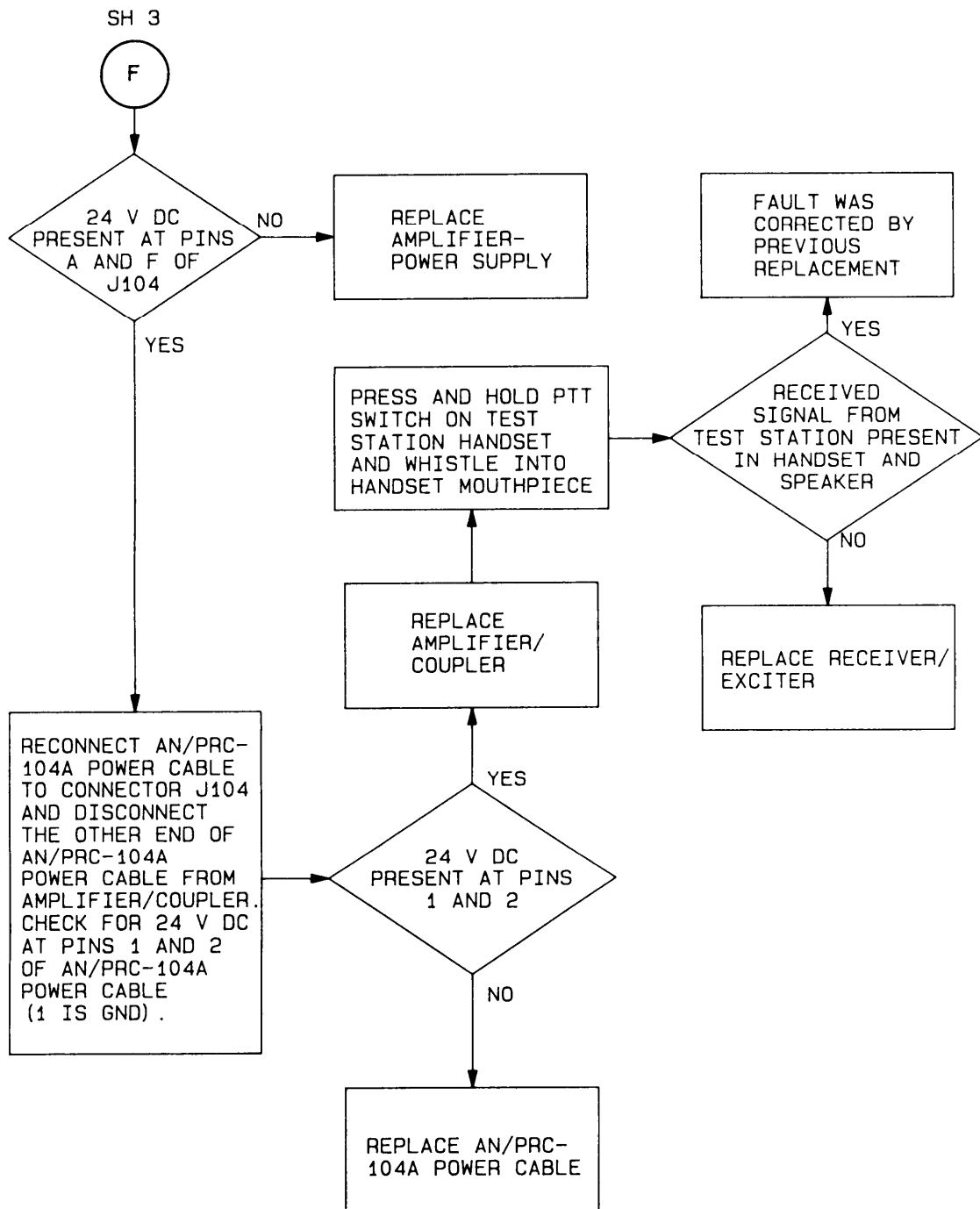

EL9WX032

Figure 6-2. Fault Isolation Flowchart (Sheet 4 of 14)

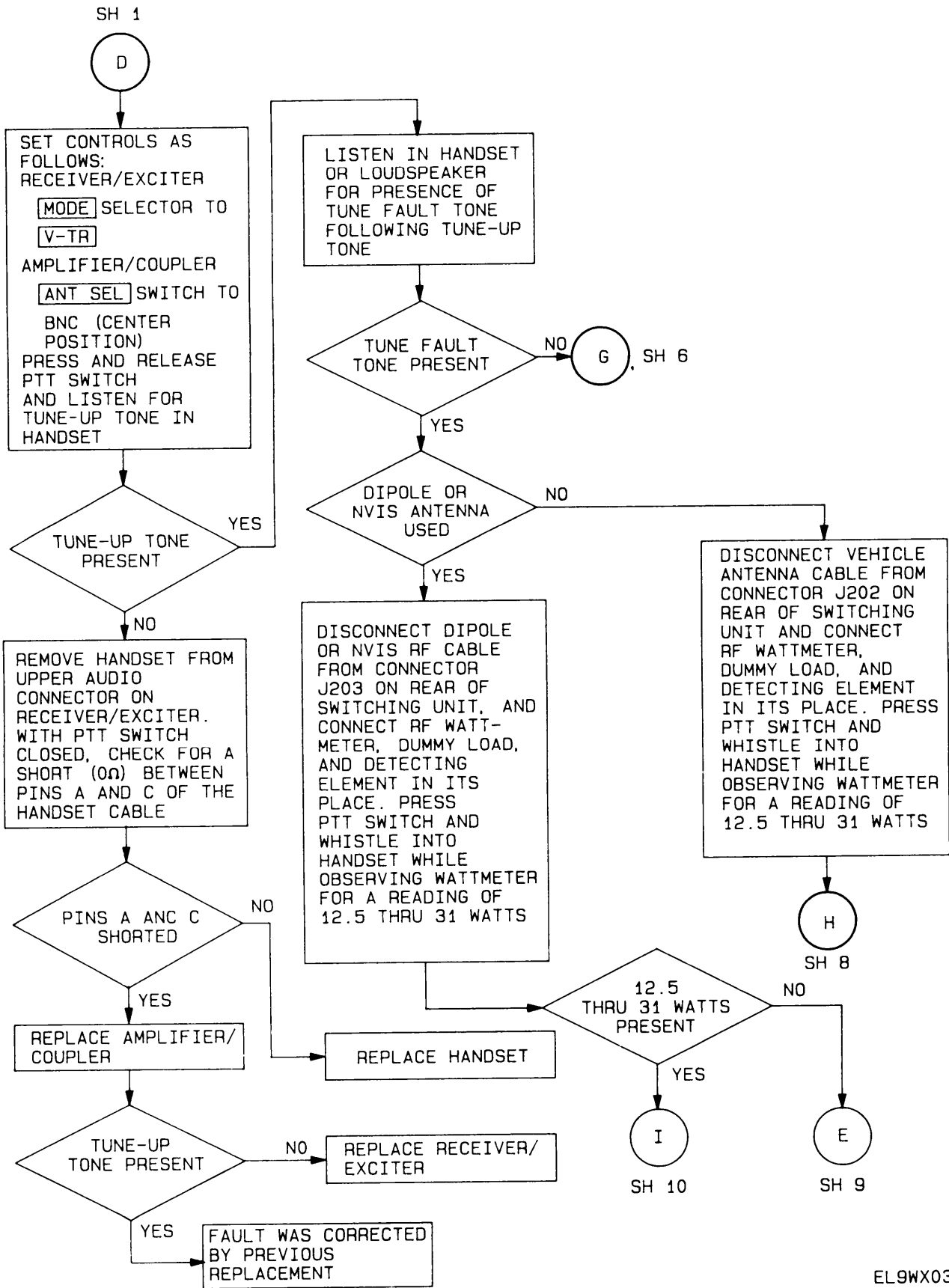

Figure 6-2. Fault isolation Flowchart (Sheet 5 of 14)

EL9WX033



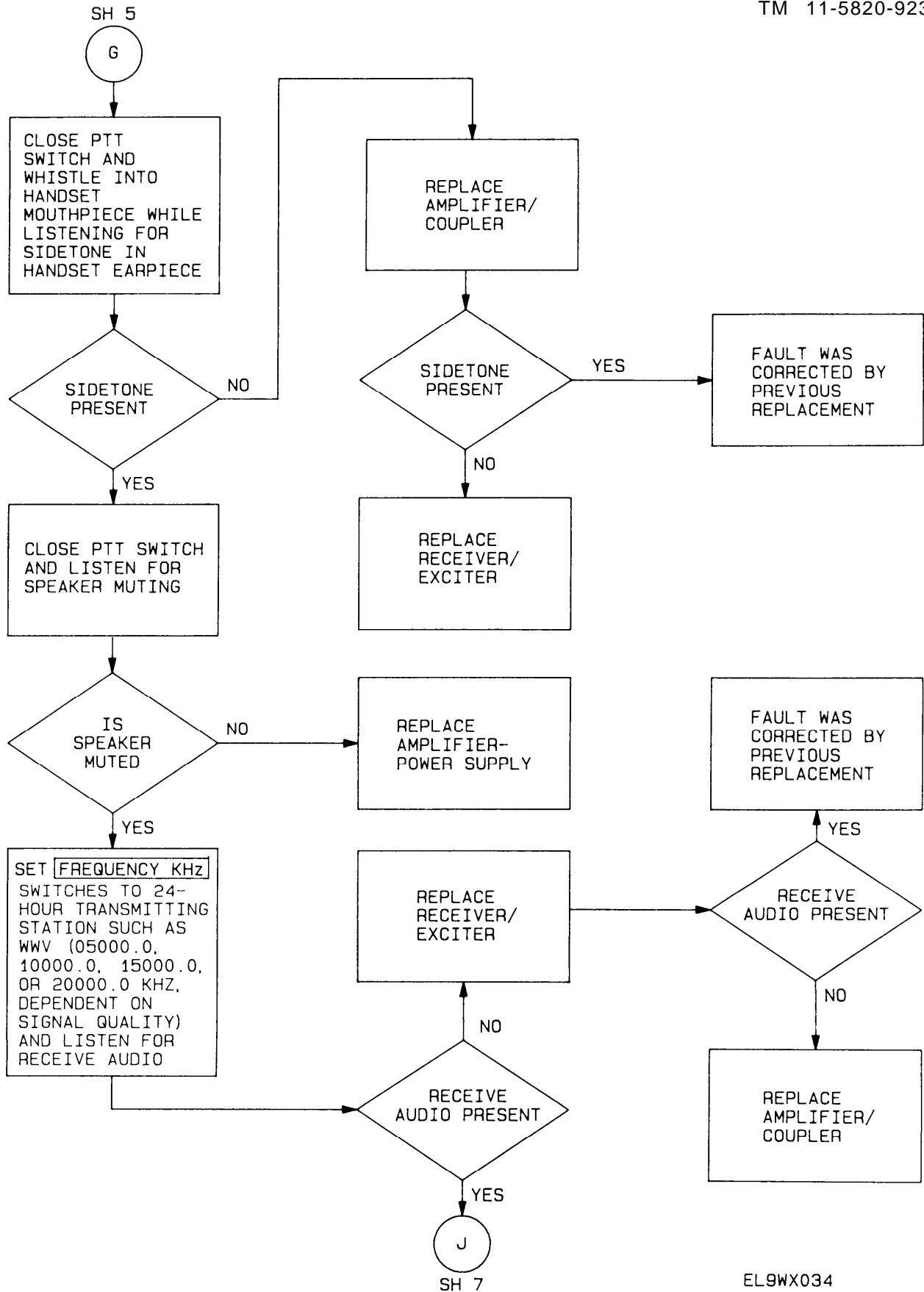
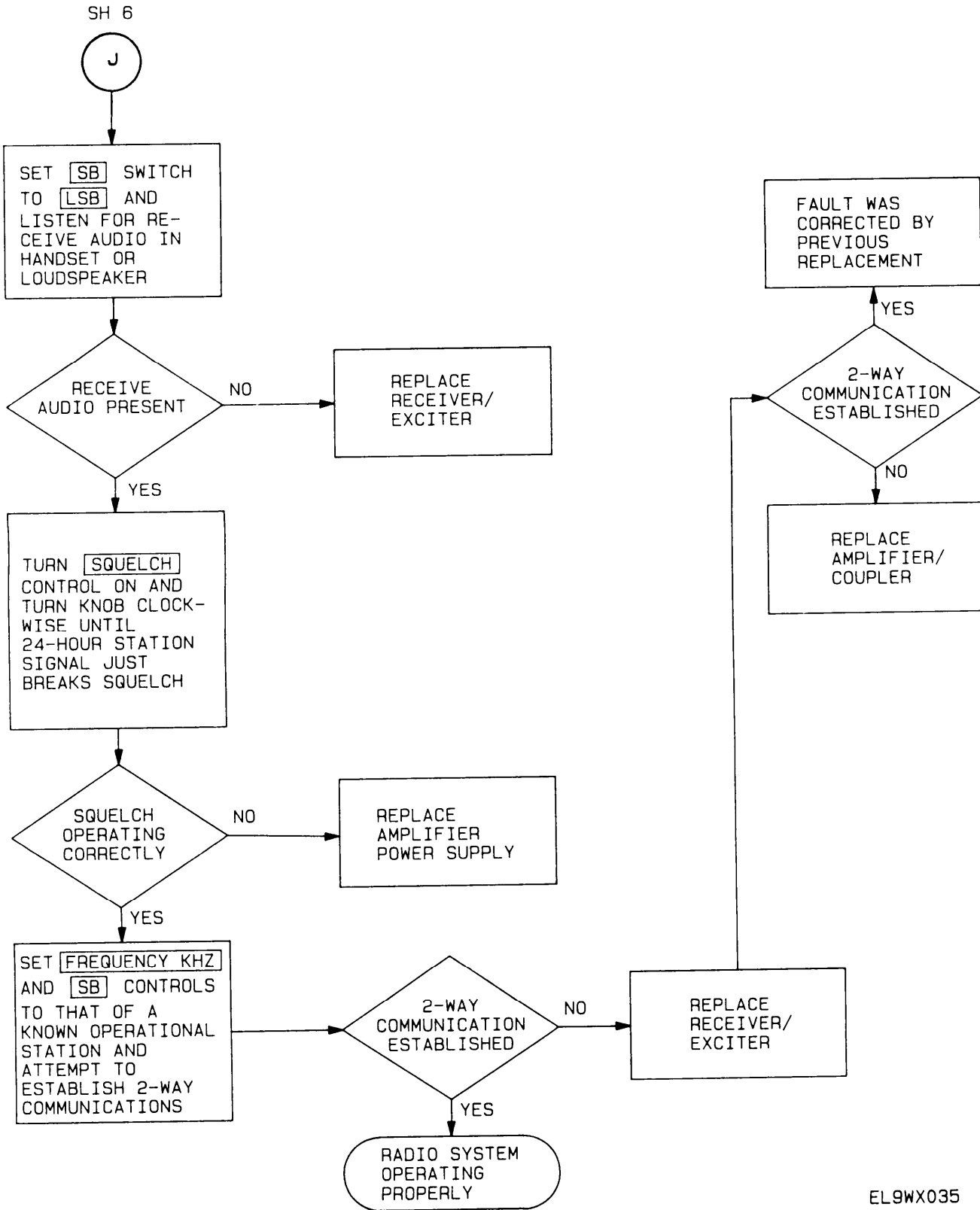
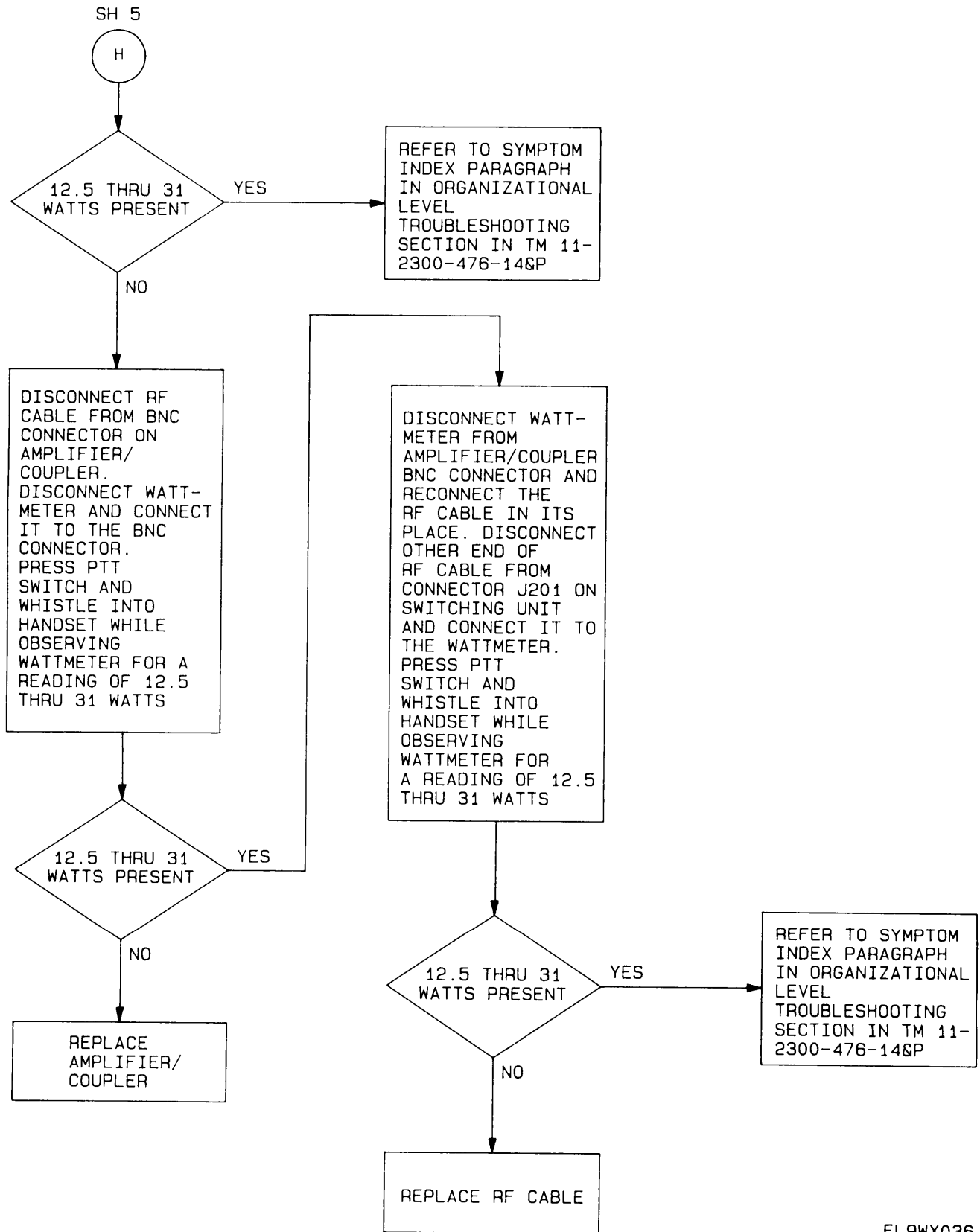

Figure 6-2. Fault Isolation Flowchart (Sheet 6 of 14)



EL9WX035

Figure 6-2. Fault Isolation Flowchart (Sheet 7 of 14)



EL9WX036

Figure 6-2. Fault Isolation Flowchart (Sheet 8 of 14)

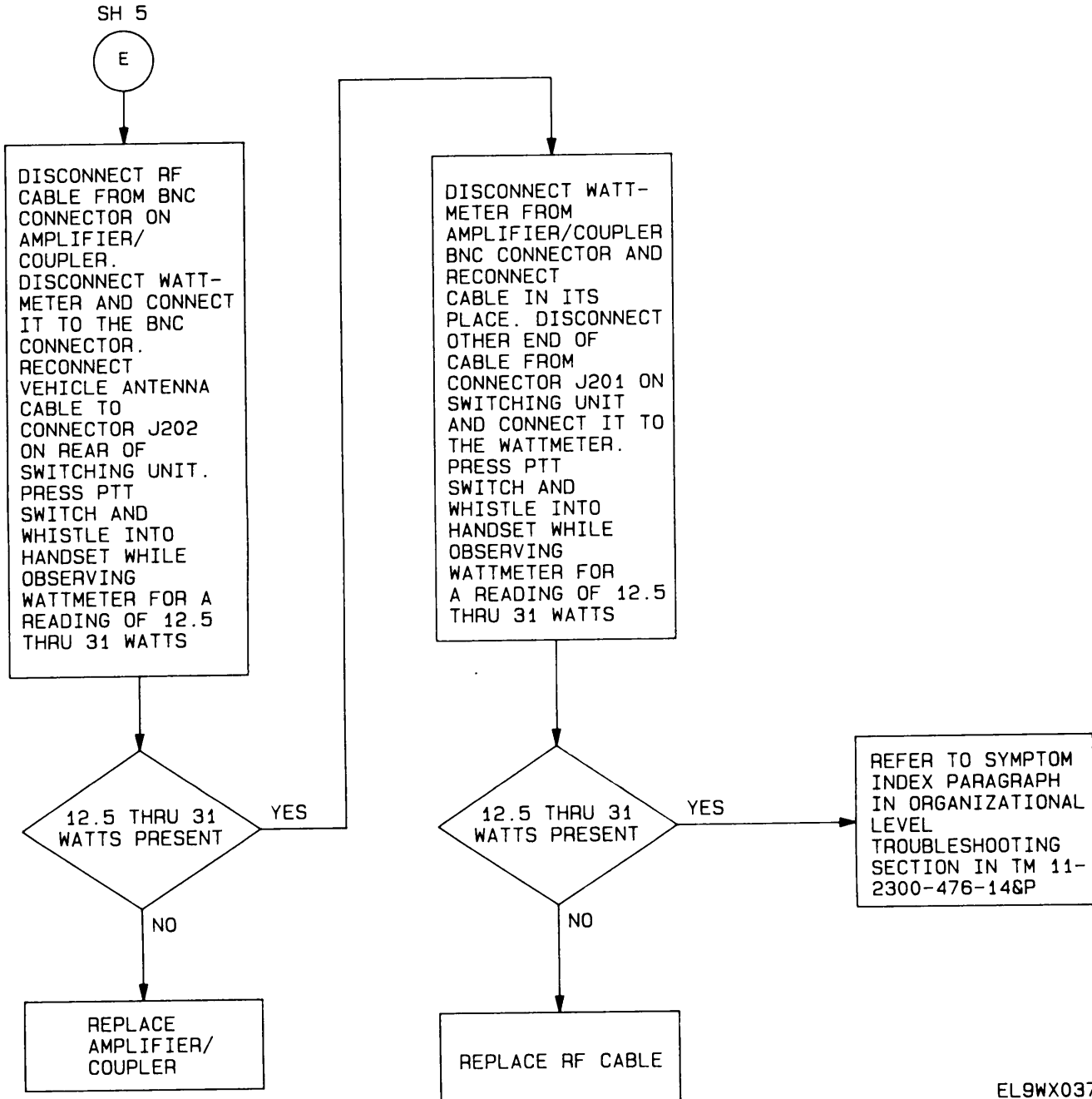

EL9WX037

Figure 6-2. Fault Isolation Flowchart (Sheet 9 of 14)

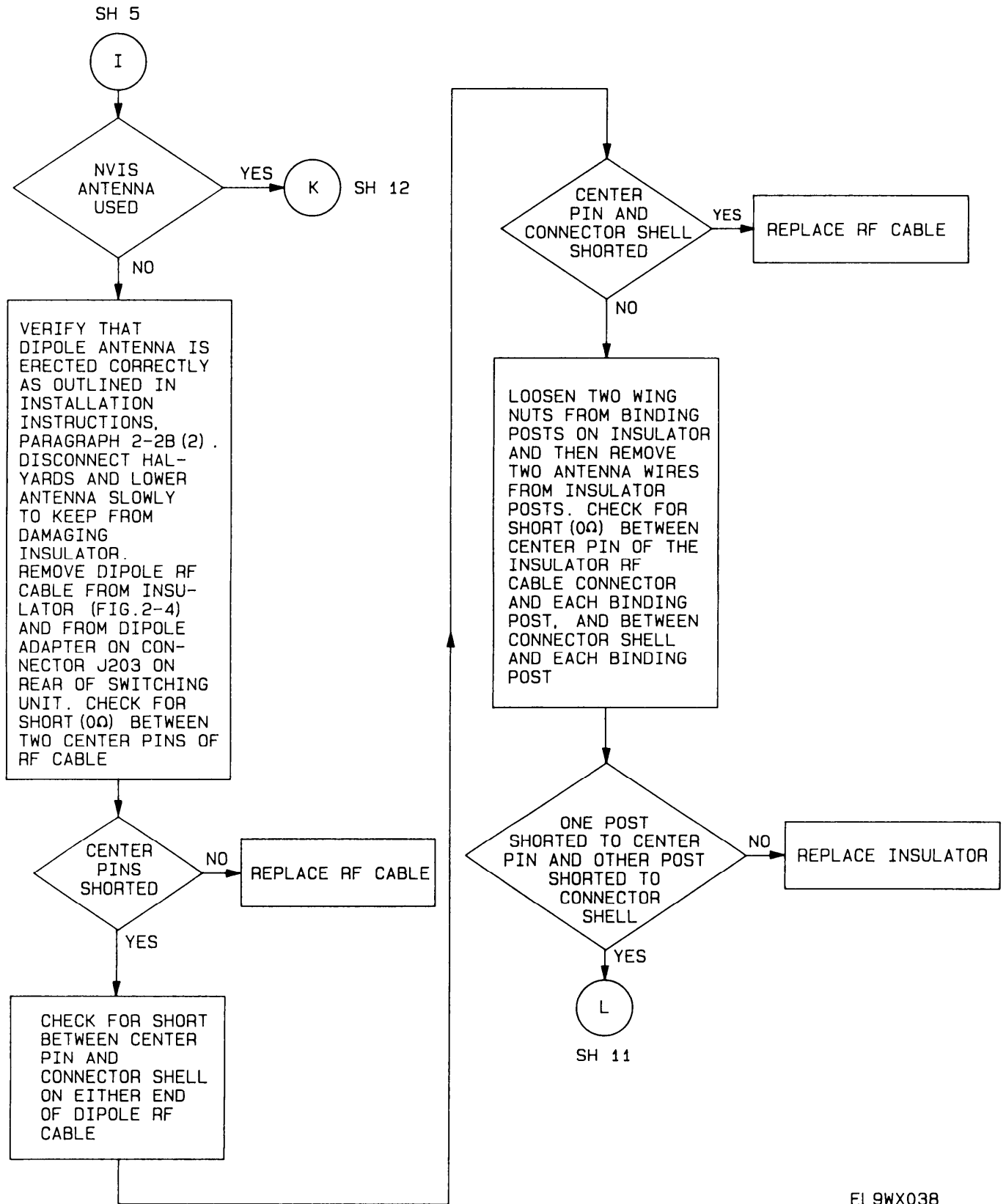

Figure 6-2. Fault isolation Flowchart (Sheet 10 of 14)

EL9WX038

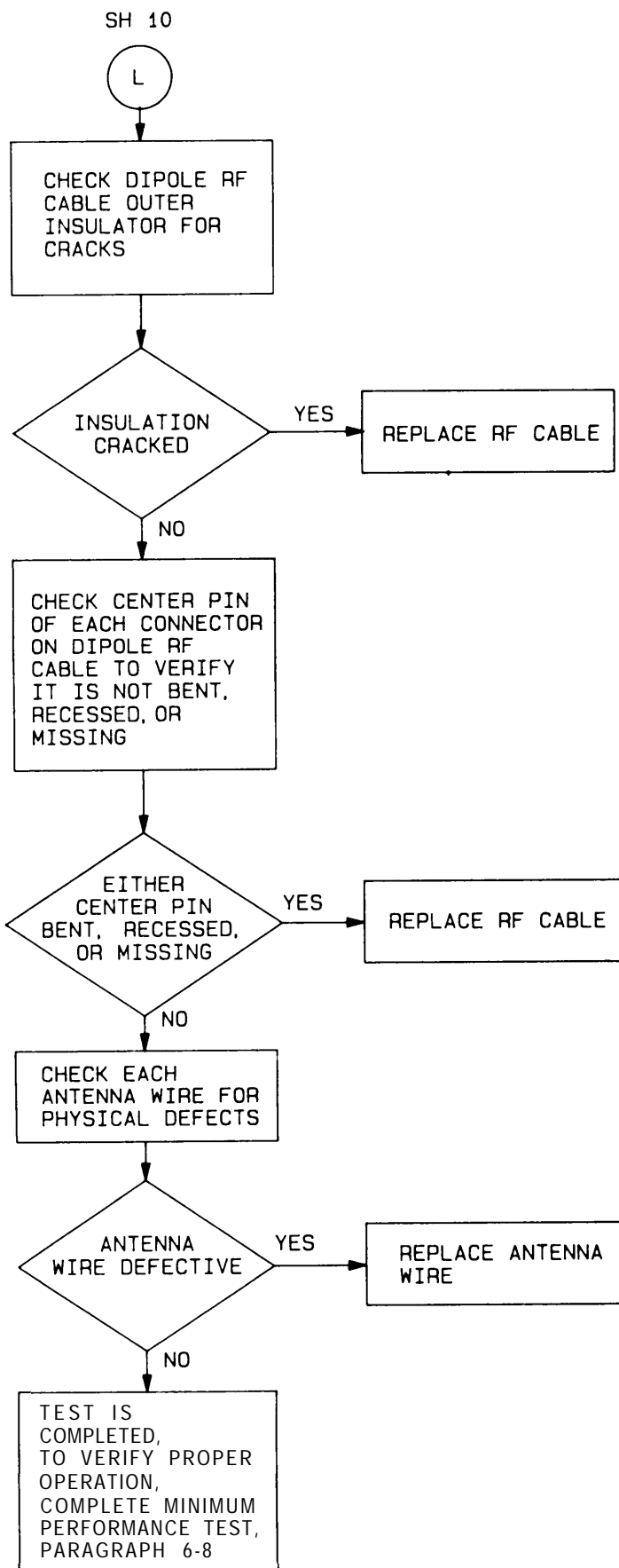

Figure 6-2. Fault Isolation Flowchart (Sheet 11 of 14)

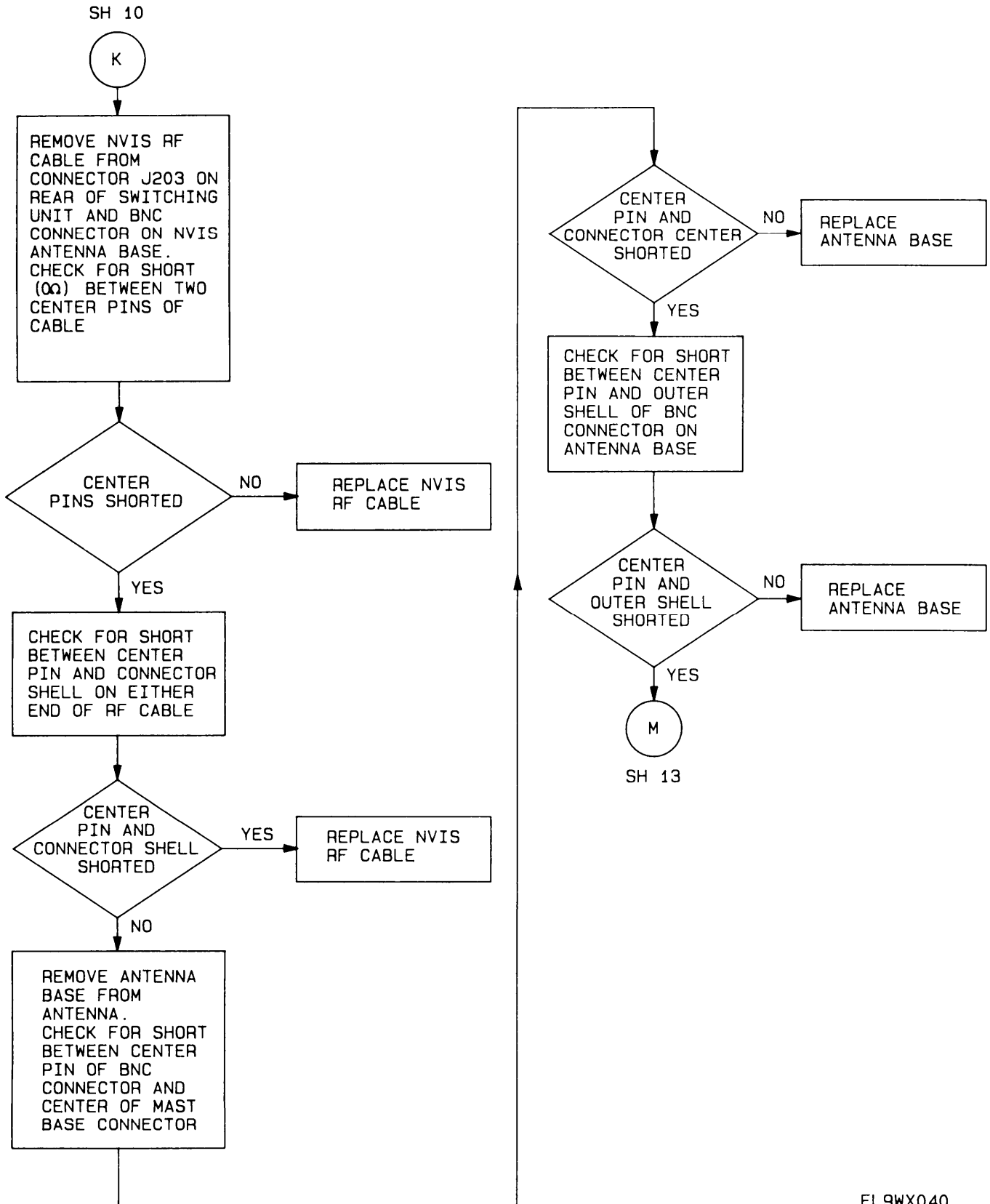
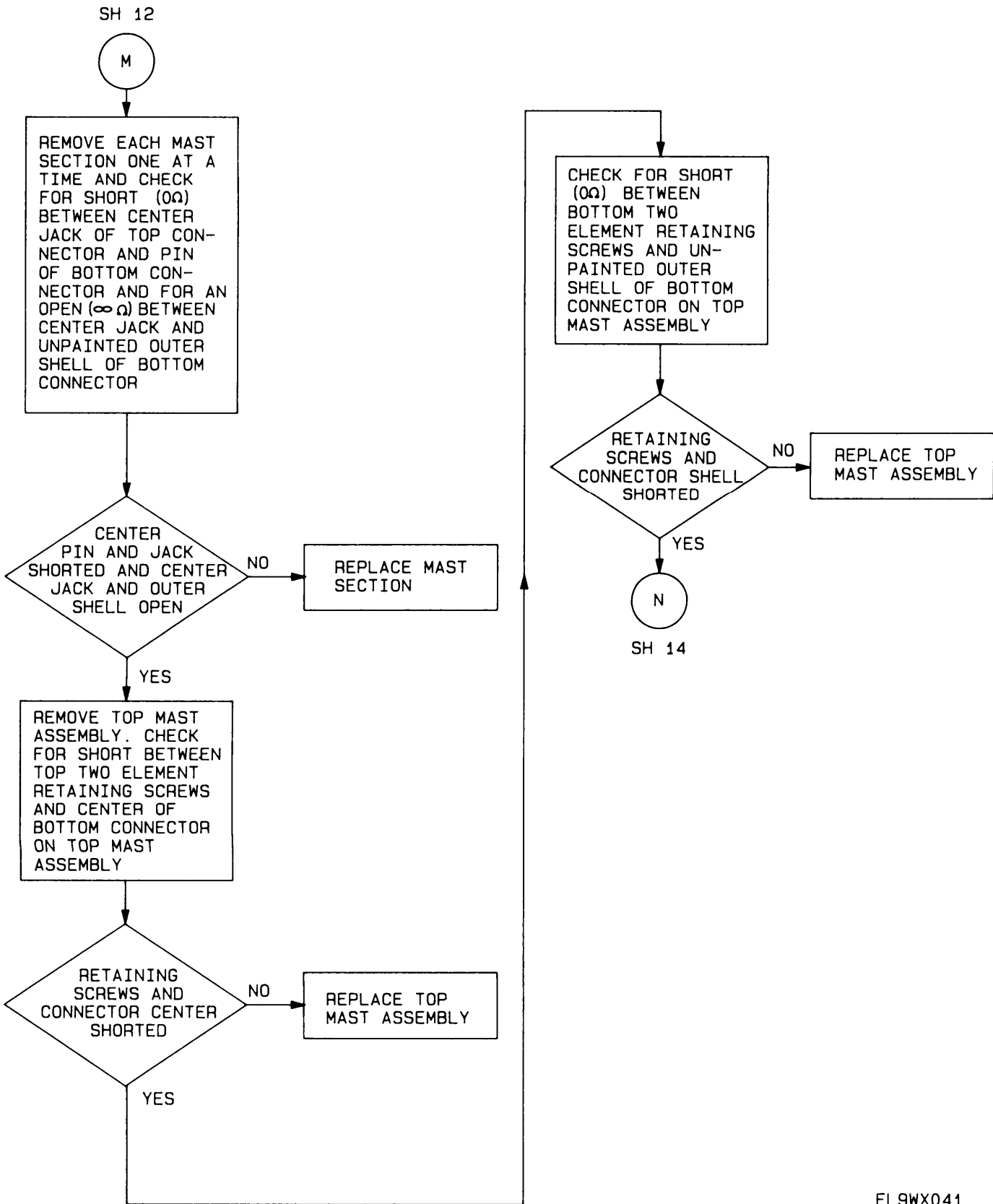

Figure 6-2. Fault Isolation Flowchart (Sheet 12 of 14)

EL9WX040



EL9WX041

Figure 6-2. Fault Isolation Flowchart (Sheet 13 of 14)



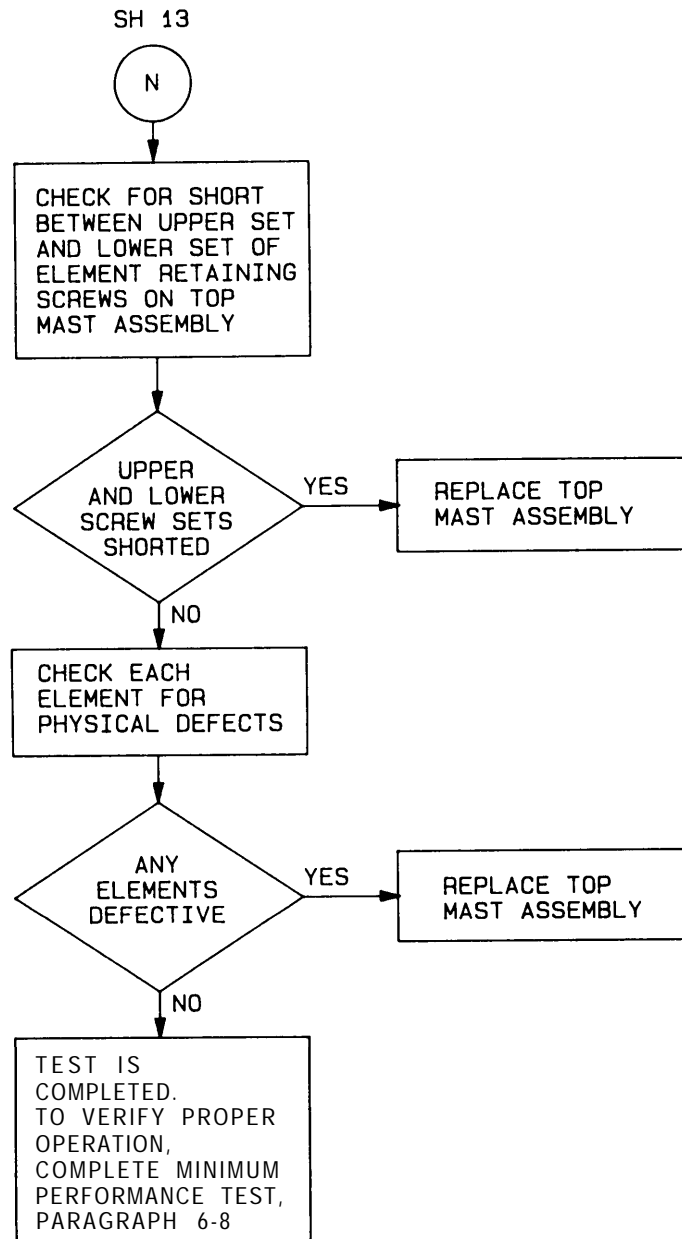

Figure 6-2. Fault isolation Flowchart (Sheet 14 of 14)

**6-9. Removal and Replacement Instructions.** This paragraph contains instructions for removing and installing the receiver/exciter, amplifier/coupler, and amplifier-power supply. Also included are instructions for replacing the AN/GRC-213 cables, handset, cw key, loudspeaker, NVIS antenna, and dipole antenna.

a. Receiver/Exciter Removal Instructions. To remove the receiver/exciter from the AN/GRC-213, proceed as follows:

- (1) Verify POWER circuit breaker on amplifier-power supply is set to OFF. If necessary, set circuit breaker to OFF.
- (2) Disconnect AN/PRC-104A power cable from AN/PRC-104A power input connector (16, fig. 6-3) on rear of amplifier/coupler (4, fig. 6-3).
- (3) Disconnect quick-release ground connector (18, fig. 6-3) between mounting base (11, fig. 6-3) and rear of receiver/exciter (3, fig. 6-3).
- (4) Disconnect rf cable from BNC connector (5, fig. 6-3) on front of amplifier/coupler (4, fig. 6-3).
- (5) Disconnect audio cable from lower AUDIO connector (1, fig. 6-3) on front of receiver/exciter (3, fig. 6-3).
- (6) Disconnect handset or cw key from upper AUDIO connector (2, fig. 6-3) on receiver/exciter (3, fig. 6-3).
- (7) Pull out and loosen fasteners (8, fig. 6-3) from hooks located on front of receiver/exciter (3, fig. 6-3) and amplifier/coupler (4, fig. 6-3) until fasteners can be disengaged from hooks.
- (8) Slide latched receiver/exciter (3, fig. 6-3) and amplifier/coupler (4, fig. 6-3) units forward to disengage retaining cleats and lift from amplifier-power supply (10, fig. 6-3).
- (9) Lay latched receiver/exciter (3, fig. 6-3) and amplifier/coupler (4, fig. 6-3) on a flat surface and unfasten front and rear latches, respectively, securing the receiver/exciter and amplifier/coupler together.
- (10) Carefully separate receiver/exciter (3, fig. 6-3) from amplifier/coupler (4, fig. 6-3).

b. Receiver/Exciter Installation Instructions. To install a replacement receiver/exciter onto the AN/GRC-213, proceed as follows:

- (1) Secure receiver/exciter (3, fig. 6-3) to amplifier/coupler (4, fig. 6-3) and fasten latches.
- (2) Place latched receiver/exciter (3, fig. 6-3) and amplifier/coupler (4, fig. 6-3) on top of amplifier-power supply (10, fig. 6-3).
- (3) Slide latched units toward rear of amplifier-power supply (10, fig. 6-3) until receiver/exciter (3, fig. 6-3) and amplifier/coupler (4, fig. 6-3) fully engage retaining cleats on amplifier-power supply.

- (4) Tighten fasteners (8, fig. 6-3) over hooks located on front of receiver/exciter (3, fig. 6-3) and amplifier/coupler (4, fig. 6-3) until both units are securely attached to top of amplifier-power supply (10, fig. 6-3).
- (5) Connect audio cable to lower AUDIO connector (1, fig. 6-3) on receiver/exciter (3, fig. 6-3).
- (6) Connect handset or cw key to upper audio connector (2, fig. 6-3) on receiver/exciter (3, fig. 6-3).
- (7) Connect rf cable to BNC connector (5, fig. 6-3) on amplifier/coupler (4, fig. 6-3).
- (8) Connect quick-release ground connector (18, fig. 6-3) between mounting base (n, fig. 6-3) and rear of receiver/exciter (3, fig. 6-3).
- (9) Connect AN/PRC-104A power cable to AN/PRC-104A power input connector (16, fig. 6-3) on rear of amplifier/coupler (4, fig. 6-3).
- (10) Complete Minimum Performance Test, paragraph 6-8, to verify proper operation of the AN/GRC-213.

c. Amplifier/Coupler Removal Instructions. To remove the amplifier/coupler from the AN/GRC-213, proceed as follows:

- (1) Verify POWER circuit breaker on amplifier-power supply is set to OFF. If necessary, set circuit breaker to OFF.
- (2) Disconnect AN/PRC-104A power cable from AN/PRC-104A power input connector (16, fig. 6-3) on rear of amplifier/coupler (4, fig. 6-3).
- (3) Disconnect quick-release ground connector (18, fig. 6-3) between mounting base (11, fig. 6-3) and rear of receiver/exciter (3, fig. 6-3).
- (4) Disconnect rf cable from BNC connector (5, fig. 6-3) on front of amplifier/coupler (4, fig. 6-3).
- (5) Disconnect audio cable from lower AUDIO connector (1, fig. 6-3) on front of receiver/exciter (3, fig. 6-3).
- (6) Disconnect handset or cw key from upper AUDIO connector (2, fig. 6-3) on receiver/exciter (3, fig. 6-3).
- (7) Pull out and loosen fasteners (8, fig. 6-3) from hooks located on front of receiver/exciter (3, fig. 6-3) and amplifier/coupler (4, fig. 6-3) until fasteners can be disengaged from hooks.
- (8) Slide latched receiver/exciter (3, fig. 6-3) and amplifier/coupler (4, fig. 6-3) units forward to disengage retaining cleats and lift from amplifier-power supply (10, fig. 6-3).

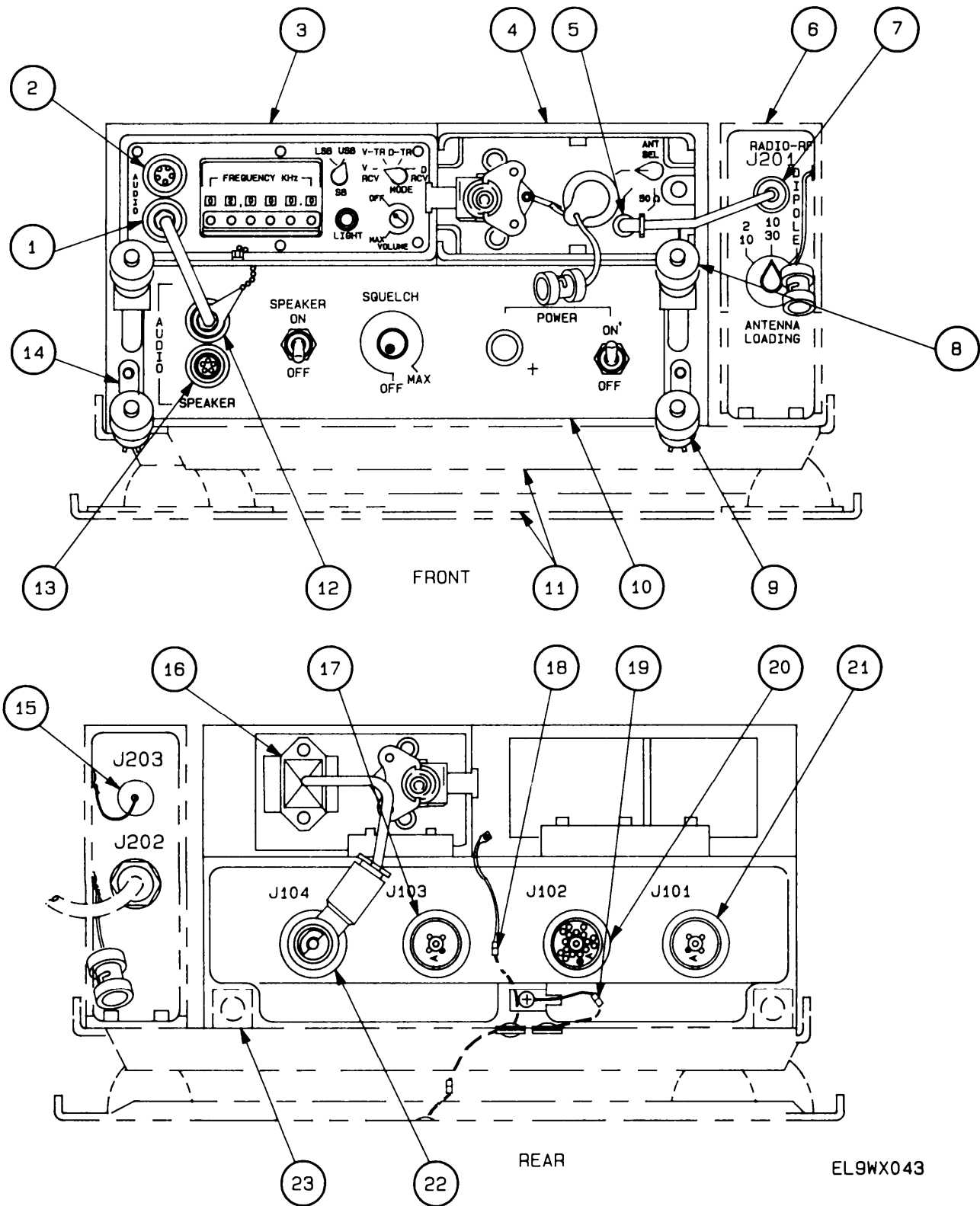

EL9WX043

Figure 6-3. Removal and Installation of AN/GRC-213 Units and Cables

- (9) Lay latched receiver/exciter (3, fig. 6-3) and amplifier/coupler (4, fig. 6-3) on a flat surface and unfasten front and rear latches, respectively, securing the receiver/exciter and amplifier/coupler together.
- (10) Carefully separate receiver/exciter (3, fig. 6-3) from amplifier/coupler (4, fig. 6-3).

d. Amplifier/Coupler Installation Instructions. To install a replacement amplifier/coupler on to the AN/GRC-213, proceed as follows:

- (1) Secure amplifier/coupler (4, fig. 6-3) to receiver/exciter (3, fig. 6-3) and fasten latches.
- (2) Place latched receiver/exciter (3, fig. 6-3) and amplifier/coupler (4, fig. 6-3) on top of amplifier-power supply (10, fig. 6-3).
- (3) Slide latched units toward rear of amplifier-power supply (10, fig. 6-3) until receiver/exciter (3, fig. 6-3) and amplifier/coupler (4, fig. 6-3) fully engage retaining cleats on amplifier-power supply.
- (4) Tighten fasteners (8, fig. 6-3) over hooks located on front of receiver/exciter (3, fig. 6-3) and amplifier/coupler (4, fig. 6-3) until both units are securely attached to top of amplifier-power supply (10, fig. 6-3).
- (5) Connect audio cable to lower AUDIO connector (1, fig. 6-3) on receiver/exciter (3, fig. 6-3).
- (6) Connect handset or cw key to upper audio connector (2, fig. 6-3) on receiver/exciter (3, fig. 6-3).
- (7) Connect rf cable to BNC connector (5, fig. 6-3) on amplifier/coupler (4, fig. 6-3).
- (8) Connect quick-release ground connector (18, fig. 6-3) between mounting base (11, fig. 6-3) and rear of receiver/exciter (3, fig. 6-3).
- (9) Connect AN/PRC-104A power cable to AN/PRC-104A power input connector (16, fig. 6-3) on rear of amplifier/coupler (4, fig. 6-3).
- (10) Complete Minimum Performance Test, paragraph 6-8, to verify proper operation of the AN/GRC-213.

e. Amplifier-Power Supply Removal Instructions. To remove the amplifier-power supply from the AN/GRC-213, proceed as follows:

- (1) For vehicles M577A1, M882, and M113A1, turn off vehicle master power switch.



Sparks may damage power cable or connector J101 (21, fig. 6-3) if POWER circuit breaker is not properly set to OFF in the following steps.

- (2) Set POWER circuit breaker on amplifier-power supply (10, fig. 6-3) to OFF.
- (3) Disconnect power cable from connector J101 (21, fig. 6-3) located on rear of amplifier-power supply (10, fig. 6-3).
- (4) If AN/VIC-1(V) is used, disconnect intercommunication cable from connector J102 (20, fig. 6-3) on rear of amplifier-power supply (10, fig. 6-3).
- (5) If parallel radio set is used, disconnect its power cable from connector J103 (17, fig. 6-3) on rear of amplifier-power supply (10, fig. 6-3).
- (6) Disconnect quick-release ground connectors (18 and 19, fig. 6-3), located on rear of receiver/exciter (3, fig. 6-3) and rear of amplifier-power supply (10, fig. 6-3), from mounting base (11, fig. 6-3).
- (7) Disconnect loudspeaker from SPEAKER AUDIO connector (13, fig. 6-3) on amplifier-power supply (10, fig. 6-3).
- (8) Disconnect handset or cw key from upper AUDIO connector (2, fig. 6-3) on receiver/exciter (3, fig. 6-3).
- (9) Disconnect rf cable from BNC connector (5, fig. 6-3) on amplifier/coupler (4, fig. 6-3).
- (10) Loosen and disengage fasteners (9, fig. 6-3) from hooks (14, fig. 6-3) located on front of amplifier-power supply (10, fig. 6-3).
- (11) Slide amplifier-power supply (10, fig. 6-3) forward until it clears the guide pin assemblies (23, fig. 6-3) and lift amplifier-power supply with latched receiver/exciter (3, fig. 6-3) and amplifier/coupler (4, fig. 6-3) free of mounting base (11, fig. 6-3).
- (12) Disconnect AN/PRC-104A power cable from connector J104 (22, fig. 6-3) located on rear of amplifier-power supply (10, fig. 6-3).

- (13) Disconnect audio cable from lower AUDIO connector (1, fig. 6-3) on receiver/exciter (3, fig. 6-3).
- (14) Loosen fasteners (8, fig. 6-3) from hooks located on front of receiver/exciter (3, fig. 6-3) and amplifier/coupler (4, fig. 6-3).
- (15) Slide latched receiver/exciter (3, fig. 6-3) and amplifier/coupler (4, fig. 6-3) forward to disengage retaining cleats and lift from amplifier-power supply (10, fig. 6-3).

f. Amplifier-Power Supply Installation Instructions. To install a replacement amplifier-power supply onto the AN/GRC-213 proceed as follows:

- (1) Place latched receiver/exciter (3, fig. 6-3) and amplifier/coupler (4, fig. 6-3) on top of amplifier-power supply (10, fig. 6-3).
- (2) Slide latched units toward rear of amplifier-power supply (10, fig. 6-3) until receiver/exciter (3, fig. 6-3) and amplifier/coupler (4, fig. 6-3) fully engage retaining cleats on rear of amplifier-power supply.
- (3) Tighten fasteners (8, fig. 6-3) over hooks located on front of receiver/exciter (3, fig. 6-3) and amplifier/coupler (4, fig. 6-3) until both units are securely attached to top of amplifier-power supply (10, fig. 6-3).
- (4) Connect audio cable (chained to front of amplifier-power supply) to lower AUDIO connector (1, fig. 6-3) on receiver/exciter (3, fig. 6-3) and to upper RADIO AUDIO connector (12, fig. 6-3) on amplifier power supply (10, fig. 6-3).
- (5) Connect AN/PRC-104A power cable to connector J104 (22, fig. 6-3) on rear of amplifier-power supply (10, fig. 6-3).
- (6) Slide amplifier-power supply (10, fig. 6-3) with latched receiver/exciter (3, fig. 6-3) and amplifier/coupler (4, fig. 6-3) onto mounting base (11, fig. 6-3) Rear of amplifier-power supply will be toward rear of mounting base. Slide amplifier-power supply straight back until it is fully seated against guide pin assembly (23, fig. 6-3) located on mounting base.
- (7) Tighten fasteners (9, fig. 6-3) over hooks (14, fig. 6-3) until amplifier-power supply (10, fig. 6-3) is securely attached to mounting base (11, fig. 6-3).
- (8) Connect handset or cw key to upper AUDIO connector (2, fig. 6-3) on receiver/exciter (3, fig. 6-3).
- (9) Connect loudspeaker to SPEAKER AUDIO connector (13, fig. 6-3) on amplifier-power supply (10, fig. 6-3).
- (10) Connect rf cable to BNC connector (5, fig. 6-3) on amplifier/coupler (4, fig. 6-3).

- (11) Connect quick-release ground connectors (18 and 19, fig. 6-3), located on rear of amplifier-power supply (10, fig. 6-3) and receiver/exciter (4, fig. 6-3), to mounting base (11, fig. 6-3).
- (12) Connect power cable to connector J101 (21, fig. 6-3) located on rear of amplifier-power supply (10, fig. 6-3).
- (13) If AN/VIC-1(V) is to be used, connect intercommunication cable to connector J102 (20, fig. 6-3) on rear of amplifier-power supply (10, fig. 6-3).
- (14) If parallel radio set is to be used, connect its power cable to connector J103 (17, fig. 6-3) on rear of amplifier-power supply (10, fig. 6-3).
- (15) Complete Minimum Performance Test, paragraph 6-8, to verify proper operation of the AN/GRC-213.

*g. AN/PRC-104A Power Cable Replacement Instructions.* To replace the AN/PRC-104A power cable, proceed as follows:

- (1) Verify POWER circuit breaker on amplifier-power supply (10, fig. 6-3) is set to OFF. If necessary, set circuit breaker to OFF.
- (2) Disconnect AN/PRC-104A power cable from connector J104 (22, fig. 6-3) on rear of amplifier-power supply (10, fig. 6-3) and AN/PRC-104A power input connector (16, fig. 6-3) on rear of amplifier/coupler (4, fig. 6-3).
- (3) Connect replacement AN/PRC-104A power cable to connector J104 (22, fig. 6-3) and AN/PRC-104A power input connector (16, fig. 6-3).
- (4) Complete Minimum Performance Test, paragraph 6-8, to verify proper operation of the AN/GRC-213.

*h. RF Cable Replacement Instructions.* To replace rf cable, proceed as follows:

- (1) Verify POWER circuit breaker on amplifier-power supply (10, fig. 6-3) is set to OFF. If necessary, set circuit breaker to OFF.
- (2) Disconnect rf cable from BNC connector (5, fig. 6-3) on amplifier-coupler (4, fig. 6-3) and RADIO-RF connector J201 (7, fig. 6-3) on switching unit (6, fig. 6-3).
- (3) Connect replacement rf cable to BNC connector (5, fig. 6-3) and RADIO-RF connector J201 (7, fig. 6-3).
- (4) Complete Minimum Performance Test, paragraph 6-8, to verify proper operation of the AN/GRC-213.



i. Audio Cable Replacement Instructions. To replace the audio cable, proceed as follows:

- (1) Verify POWER circuit breaker on amplifier-power supply (10, fig. 6-3) is set to OFF. If necessary, set circuit breaker to OFF.
- (2) Disconnect audio cable from lower AUDIO connector (1, fig. 6-3) on receiver/exciter (3, fig. 6-3) and RADIO AUDIO connector (12, fig. 6-3) on amplifier-power supply (10, fig. 6-3).
- (3) Disconnect chain (secures cable to amplifier-power supply) from amplifier-power supply (10, fig. 6-3) by removing machine screw and nut.



Do not connect audio cable to SPEAKER AUDIO connector (13, fig. 6-3) on amplifier-power supply. Otherwise, continuous transmission will result when the other end is connected to either AUDIO connector (1 or 2, fig. 6-3) of the receiver/exciter. This could damage the AN/PRC-104A.

- (4) Connect replacement audio cable to RADIO AUDIO connector (12, fig. 6-3) and lower AUDIO connector (1, fig. 6-3).
- (5) Connect bead chain (connected to audio cable) to amplifier-power supply with machine screw and nut.
- (6) Complete Minimum Performance Test, paragraph 6-8, to verify proper operation of the AN/GRC-213.

j. Handset Replacement Instructions. To replace the handset, proceed as follows:

- (1) Disconnect handset from upper AUDIO connector (2, fig. 6-3) on receiver/exciter (3, fig. 6-3).
- (2) Connect replacement handset to upper AUDIO connector (2, fig. 6-3).
- (3) Complete Minimum Performance Test, paragraph 6-8, to verify proper operation of the AN/GRC-213.

k. CW Key Replacement Instructions. To replace the cw key, proceed as follows:

- (1) Disconnect cw key from upper AUDIO connector (2, fig. 6-3) on receiver/exciter (3, fig. 6-3).
- (2) Connect replacement cw key to upper AUDIO connector (2, fig. 6-3).
- (3) Complete Minimum Performance Test, paragraph 6-8, to verify proper operation of the AN/GRC-213.

1. Loudspeaker Replacement Instructions. To replace the loudspeaker, proceed as follows:

- (1) Disconnect the loudspeaker cable from SPEAKER AUDIO connector (13, fig. 6-3) on amplifier-power supply (10, fig. 6-3).
- (2) Remove two bolts (1, fig. 6-4) securing loudspeaker to vehicle to free loudspeaker.
- (3) Install replacement loudspeaker with two bolts (1, fig. 6-4), star washers, and nuts.
- (4) Connect cable of replacement loudspeaker to SPEAKER AUDIO connector (13, fig. 6-3).
- (5) Complete Minimum Performance Test, paragraph 6-8, to verify proper operation of the AN/GRC-213.

m. Dipole Antenna Replacement Instructions. To replace any part of the dipole antenna, refer to the appropriate following subparagraph.

- (1) *RF cable.* To replace the dipole rf cable, proceed as follows:
  - (a) Disconnect halyards from support(s) (fig. 2-8, 2-9, or 2-10) and lower antenna slowly to keep from damaging insulator, if not previously done.
  - (b) Disconnect rf cable from insulator (fig. 2-4) and dipole adapter connected to connector J203 (15, fig. 6-3) on rear of switching unit (6, fig. 6-3).
  - (c) Connect replacement rf cable to insulator (fig. 2-4) and dipole adapter on connector J203 (15, fig. 6-3).



Allow antenna assembly to sag at least 6 inches when installing it in the following step to avoid damaging the antenna.

- (d) Tie halyards to support(s) (fig. 2-8, 2-9, or 2-10). Refer to paragraph 2-2b (2), step (j), for support selection.

#### NOTE

The dipole rf cable should be at right angles to the antenna wires for the first few feet from the connection at the insulator. Lay dipole rf cable out as straight as possible; do not allow the cable to form loops.

- (e) Complete Minimum Performance Test, paragraph 6-8, to verify proper operation of the AN/GRC-213.

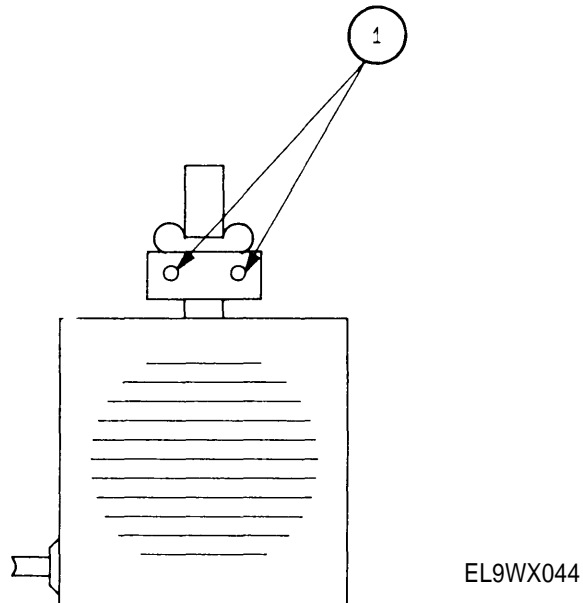

Figure 6-4. Loudspeaker Replacement

- (2) *Insulator.* To replace the dipole insulator, proceed as follows:
- (a) Disconnect halyards from support(s) (fig. 2-8, 2-9, or 2-10 and lower antenna slowly-to keep from damaging the insulator, if not previously done.
  - (b) Loosen two wing nuts from posts (fig. 2-4) and remove antenna wires from insulator.
  - (c) Disconnect rf cable from insulator (fig. 2-4).
  - (d) Connect rf cable to replacement insulator (fig. 2-4).
  - (e) Connect antenna wires over posts on insulator (fig. 2-4) and tighten wing nuts to secure antenna wires to insulator.

**CAUTION**

Allow antenna assembly to sag at least 6 inches when installing it in the following step to avoid damaging the antenna.

- (f) Tie halyards to support(s) (fig. 2-8, 2-9, or 2-10). Refer to paragraph 2-2b (2), step (j), for support selection.

NOTE

The dipole rf cable should beat right angles to the antenna wires for the first few feet from the connection at the insulator. Lay dipole rf cable out as straight as possible; do not allow the cable to form loops.

- (g) Complete Minimum Performance Test, paragraph 6-8, to verify proper operation of the AN/GRC-213.
- (3) *Halyard*. To replace one of the dipole halyards, proceed as follows:
  - (a) Disconnect halyard from support (fig. 2-8, 2-9, or 2-10) and lower antenna slowly to keep from damaging the insulator, if not previously done.
  - (b) Remove halyard from reel assembly (fig. 2-7).
  - (c) Connect replacement halyard to reel assembly (fig. 2-7) and raise antenna back up.



Allow antenna assembly to sag at least 6 inches when installing it in the following step to avoid damaging the antenna.

- (d) Tie halyards to support(s) (fig. 2-8, 2-9, or 2-10). Refer to paragraph 2-2b (2), step (j), for support selection.

NOTE

The dipole rf cable should beat right angles to the antenna wires for the first few feet from the connectional the insulator. Lay dipole rf cable out as straight as possible; do not allow the cable to form loops.

- (e) Complete Minimum Performance Test, paragraph 6-8, to verify proper operation of the AN/GRC-213.
- (4) *Reel Assembly*. To replace one of the dipole reel assemblies, proceed as follows:
  - (a) Disconnect halyards from support(s) (fig. 2-8, 2-9, or 2-10) and lower antenna slowly to keep from damaging the insulator, if not previously done.
  - (b) Loosen wing nut and then remove antenna wire from insulator post on side of defective reel assembly (fig. 2-4).

- (c) Disconnect halyard from reel assembly (fig. 2-7).
- (d) Remove antenna wire from reel assembly (fig. 2-7, 2-8).
- (e) Connect antenna wire to replacement reel assembly (fig. 2-7, 2-8).
- (f) Connect halyard to replacement reel assembly (fig. 2-7).
- (g) Connect antenna wire over post on insulator and tighten wing nut to secure antenna wire to insulator (fig. 2-4).

**CAUTION**

Allow antenna assembly to sag at least 6 inches when installing it in the following step to avoid damaging the antenna.

- (h) Tie halyards to support(s) (fig. 2-8, 2-9, or 2-10). Refer to paragraph 2-2b (2), step (j), for support selection.

**NOTE**

The dipole rf cable should beat right angles to the antenna wires for the first few feet from the connectional the insulator. Lay dipole rf cable out as straight as possible; do not allow the cable to form loops.

- (i) Complete Minimum Performance Test, paragraph 6-10, to verify proper operation of the AN/GRC-213.
- (5) *Antenna Wires.* To replace one of the dipole antenna wires, proceed as follows:
- (a) Disconnect halyards from support(s) (fig. 2-8, 2-9, or 2-10) and lower antenna slowly to keep from damaging the insulator, if not previously done.
  - (b) Loosen wing nut and then remove antenna wire to be replaced from post on insulator (fig. 2-4).
  - (c) Remove antenna wire from reel assembly (fig. 2-7, 2-8).
  - (d) Connect replacement antenna wire to reel assembly (fig. 2-7, 2-8).
  - (e) Connect other end of replacement antenna wire to post on insulator and tighten wing nut to secure antenna wire to insulator (fig. 2-4).

**CAUTION**

Allow antenna assembly to sag at least 6 inches when installing it in the following step to avoid damaging the antenna.

- (f) Tie halyards to support(s) (fig. 2-8, 2-9, or 2-10). Refer to paragraph 2-2b (2), step (j) for support selection.

**NOTE**

The dipole rf cable should beat right angles to the antenna wires for the first few feet from the connectional the insulator. Lay dipole rf cable out as straight as possible; do not allow the cable to form loops.

- (g) Complete Minimum Performance Test, paragraph 6-10, to verify proper operation of the AN/GRC-213.

*n.* NVIS Antenna Replacement Instructions. To replace any part of the NVIS antenna, refer to the appropriate subparagraph below.

- (1) *Antenna Base.* To replace the antenna base, proceed as follows:
  - (a) Disconnect NVIS rf cable from antenna base BNC connector (6, fig. 6-5).
  - (b) Place replacement antenna base (7, fig. 6-5) near base of antenna in use.
  - (c) Slide bottom mast section (5, fig. 6-5) and erected antenna up from antenna base (7, fig. 6-5) (while holding base to ground), if not previously done, until antenna base is free of mast sections. Be sure not to twist or pull excessively on the elements (1, fig. 6-5).
  - (d) Place replacement antenna base (7, fig. 6-5) under bottom mast section(s) and lower antenna down until firmly seated on replacement base.
  - (e) Verify that antenna elements (1, fig. 6-5) are not shorted to each other or to the mast and that the mast is vertical and straight. Adjust the top mast assembly direction or element tension if necessary.
  - (f) Connect NVIS rf cable to BNC connector (6, fig. 6-5) on replacement antenna base.
  - (g) Complete Minimum Performance Test, paragraph 6-10, to verify proper operation of the AN/GRC-213.

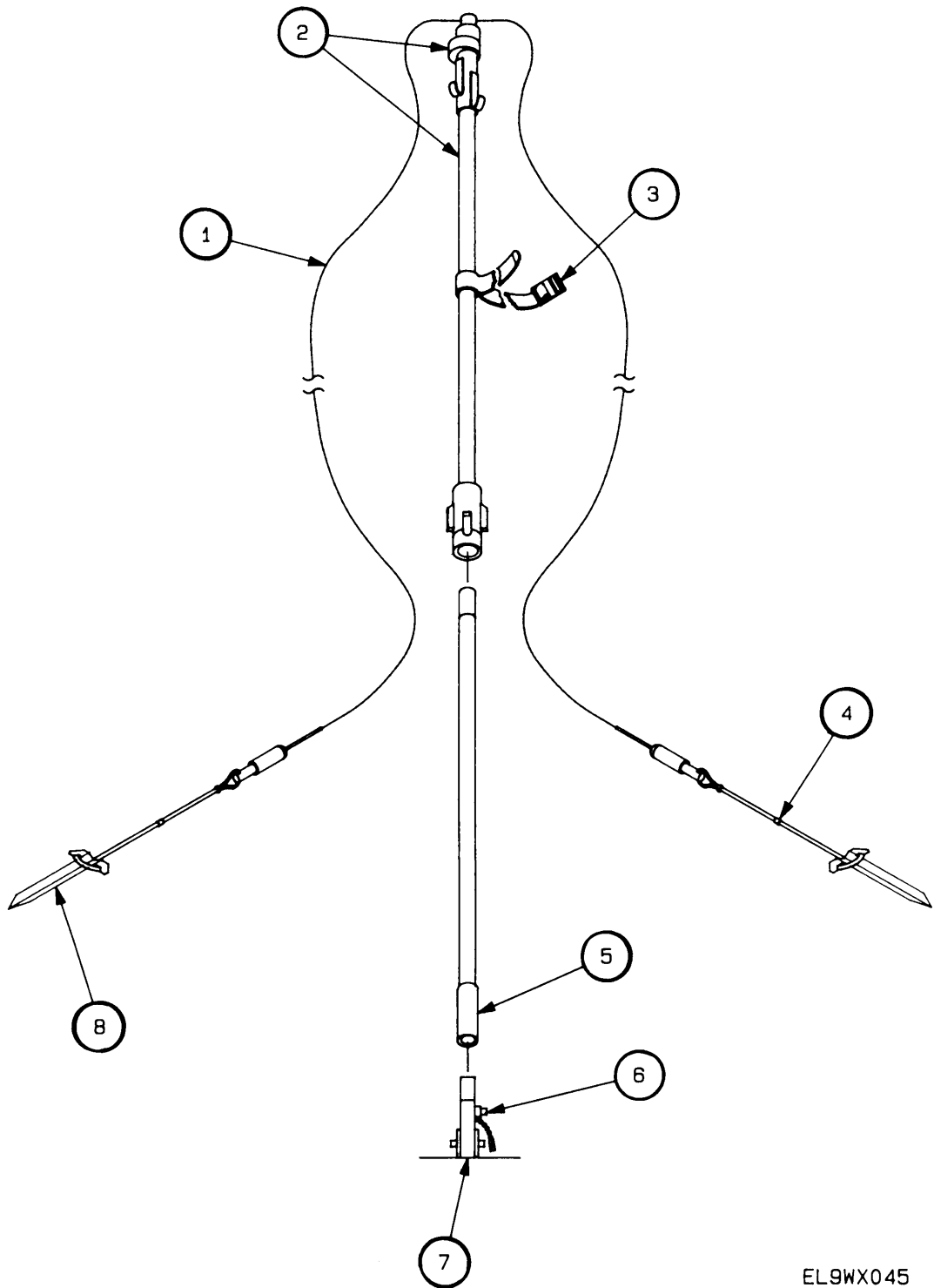

EL9WX045

Figure 6-5. NVIS Antenna Replacement

- (2) *Mast Section.* To replace one of the mast sections, proceed as follows:
- (a) Separate faulty mast section (5, fig. 6-5) from other mast section(s) if not previously done.
  - (b) Slide replacement mast section(s) up into antenna mast until firmly connected.
  - (c) Lower antenna mast with replacement section down onto lower mast section or antenna base.
  - (d) Complete Minimum Performance Test, paragraph 6-8, to verify proper operation of the AN/GRC-213.

- (3) *Top Mast Assembly.* To replace the topmast assembly (with elements), proceed as follows:
- (a) Lower top mast assembly (2, fig. 6-5) by removing each of the mast sections, if not previously done. Slide topmast assembly down onto antenna base (7, fig. 6-5).
  - (b) Coil each of the four elements (1, fig. 6-5) (one at a time) by removing anchor (8, fig. 6-5) from ground and wrapping element wire around top mast section (2, fig. 6-5) hooks.
  - (c) Fasten webbing strap (3, fig. 6-5) around coiled elements (1, fig. 6-5) and remove topmast assembly (2, fig. 6-5) from antenna base (7, fig. 6-5).
  - (d) Slide replacement topmast assembly (2, fig. 6-5) down onto antenna base (7, fig. 6-5).
  - (e) Unfasten webbing strap (3, fig. 6-5) and uncoil elements (1, fig. 6-5) from top mast assembly (2, fig. 6-5) one at a time. Verify antenna elements are stretched along in direction they leave top mast assembly and are not shorted to each other or mast. If necessary, adjust direction of elements.
  - (f) Install anchors (8, fig. 6-5) in ground at position indicated by sleeve cable markers (4, fig. 6-5) (crimped spacer clamp). Leave slack in elements lying on the ground.

#### NOTE

Dirty mast sections will reduce NVIS antenna performance.

- (g) Before connecting mast sections, wipe unpainted surfaces clean of mud or dirt to provide good electrical contact.



- (h) Assemble mast by raising topmast assembly (2, fig. 6-5) and inserting each of the seven 22-inch mast sections (5, fig. 6-5) one at a time. Insert bottom mast section in antenna base (7, fig. 6-5).
- (i) Adjust tension on all elements (1, fig. 6-5) until mast is vertical and straight. Elements need not be excessively taut.
- (j) Complete Minimum Performance Test, paragraph 6-10, to verify proper operation of the AN/GRC-213.

**6-10. Minimum Performance Test.** The minimum performance test is to be performed on the AN/GRC-213 when it is installed on an installation kit in a vehicle, prior to each use, and upon replacement of any unit or accessory. This test is comprised of three sections, which check the receiver function, transmitter function, and the overall AN/GRC-213. Another similar radio set, which is set to a known operating frequency, is needed to perform this test. The entire test should be completed to verify the system is operating properly.

- a. Receiver Function. To check the receiver function of the AN/GRC-213, proceed as follows:

#### NOTE

If any of the minimum test requirements outlined in this test are not attained or if fault tones are evident, notify organizational maintenance.

- (1) Verify that the installation kit has been properly installed as outlined in the Installation Instructions paragraph of TM 11-2300-476-14&P. Also verify that there is no evident damage that would affect operation. If the installation kit is improperly installed or damage is evident, notify organizational maintenance.
- (2) Verify that AN/GRC-213 has been properly mounted on the installation kit per paragraph 2-2 of this manual. Also verify that appropriate connections have been made per paragraph 2-3 of this manual. Complete any necessary mounting or connections as outlined.
- (3) Set the AN/GRC-213 controls as outlined in the following subparagraphs.
  - (a) Receiver/Exciter. Set the receiver/exciter controls as follows:
    - 1 Set FREQUENCY KHz switches (2, fig. 6-6) to the operating frequency of another similar unit. Frequency should be displayed in indicator windows (1, fig. 6-6).
    - 2 Set MODE selector switch (5, fig. 6-6) to V RCV.

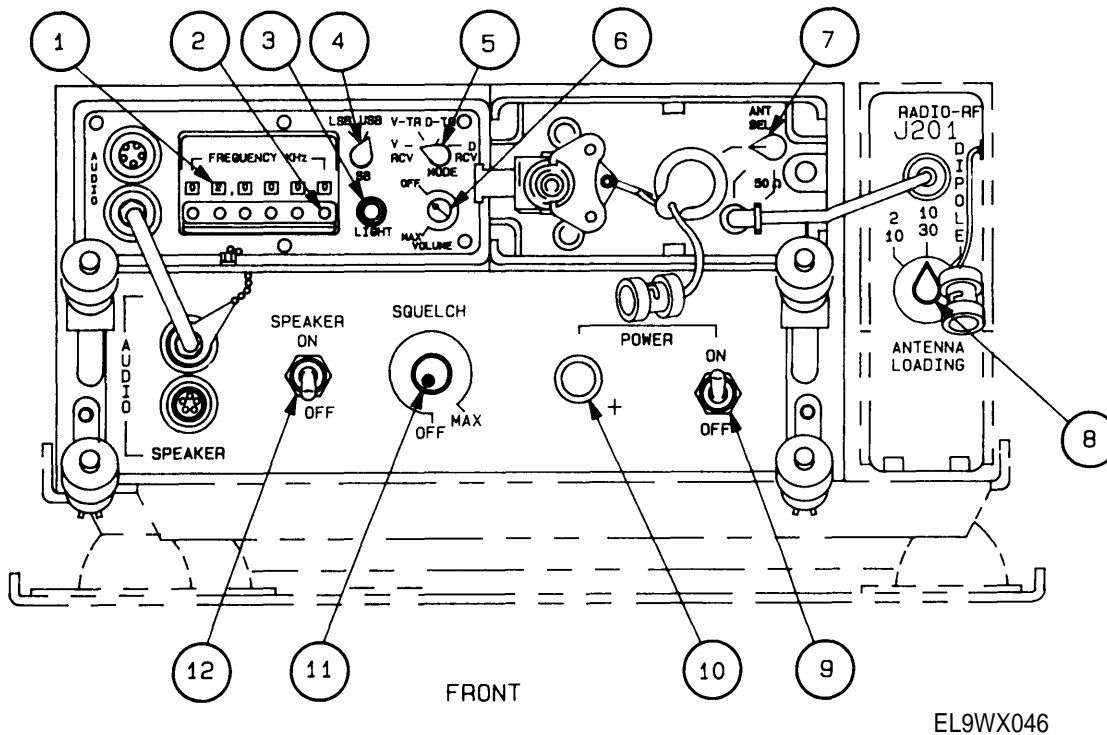

Figure 6-6. Controls and Indicators for Minimum Performance Test

- 3 Set SB selector switch (4, fig. 6-6) to USB. Verify other similar unit is also set to USB; set switch if necessary.
- 4 Set VOLUME OFF/MAX switch control (6, fig. 6-6) to OFF.
- (b) Amplifier/Coupler. Set the amplifier/coupler ANT SEL switch (7, fig. 6-6) to the center position (BNC connector).
- (c) Amplifier-Power Supply. Set the amplifier-power supply controls as follows:
  - 1 Set SPEAKER switch (12, fig. 6-6) to OFF.
  - 2 Set SQUELCH control (11, fig. 6-6) to OFF (fully counterclockwise).
  - 3 Set POWER circuit breaker (9, fig. 6-6) to ON.

- (d) Switching Unit. Set the ANTENNA LOADING switch (8, fig. 6-6) on the switching unit (part of installation kit) as follows:
- 1 If the whip antenna is being used, set ANTENNA LOADING switch (8, fig. 6-6) to appropriate position, 2/10 or 10/30 (2 to 10 MHz or 10 to 30 MHz), for the operating frequency chosen.
  - 2 If dipole or NVIS antenna is being used, set ANTENNA LOADING switch (8, fig. 6-6) to DIPOLE, regardless of operating frequency.
- (4) Turn VOLUME OFF/MAX switch control (6, fig. 6-6) on the receiver/exciter to midrange.
- (5) Verify the following conditions are present:

#### NOTE

Failure to achieve the conditions described in the following steps (b) and (c) does not warrant a high maintenance priority. (The AN/GRC-213 will still perform its mission.) Failure to achieve the condition in step (a) may demand immediate repair.

- (a) Transmission from similar unit is heard in handset earpiece.
  - (b) Light is visible in frequency indicator windows (1, fig. 6-6) when LIGHT switch (3, fig. 6-6) on receiver/exciter is pressed.
  - (c) The POWER switch light (10, fig. 6-6) on amplifier-power supply is on.
- (6) Adjust the VOLUME OFF/MAX switch control (6, fig. 6-6) on receiver/exciter to a comfortable listening level.
  - (7) Set SPEAKER switch (12, fig. 6-6) on amplifier-power supply to ON and verify the transmission signal from the similar unit can be heard on the loudspeaker.
  - (8) Adjust SQUELCH control (11, fig. 6-6) on amplifier-power supply until transmission signal from similar unit just breaks squelch or is just heard in the loudspeaker.
  - (9) Set SB selector switch (4, fig. 6-6) on receiver/exciter to LSB and monitor the signal for clarity. Then, set SB selector switch back to USB position.

b. Transmit Function. To check the transmit function of the AN/GRC-213, proceed as follows:

- (1) Adjust AN/GRC-213 controls as outlined in the following subparagraphs.
  - (a) Receiver/Exciter. Set the receiver/exciter controls as follows:
    - 1 Set MODE selector switch (5, fig. 6-6) to V-TR position.
    - 2 Change the frequency (1 and 2, fig. 6-6) to unauthorized operational frequency to establish contact with the Net Control Station or other operators.
  - (b) Switching Unit. Set the ANTENNA LOADING switch (8, fig. 6-6) on the switching unit (part of installation kit) control as follows:
    - 1 If the whip antenna is being used, set ANTENNA LOADING switch to appropriate position, 210 or 1030 (2 to 10 MHz or 10 to 30 MHz), for the operating frequency chosen.
    - 2 If dipole or NVIS antenna is being used, set ANTENNA LOADING switch to DIPOLE, regardless of operating frequency.
- (2) Press and release the push-to-talk (PTT) switch on the handset and verify the following:
  - (a) A tuning tone (less than 12 seconds in duration).
  - (b) No audible fault tones (beeping sound).
  - (c) Sidetone in handset when transmitting.
  - (d) Loudspeaker muted during transmission.

c. System Check. To check the overall system, proceed as follows:

- (1) Establish two-way communication with another radio set and check the quality of received and transmitted signals.
- (2) If the AN/GRC-213 is not to be used further, perform the following:
  - (a) Set FREQUENCY KHz switches (2, fig. 6-6) to 05000.00 KHz.
  - (b) Set SPEAKER switch (12, fig. 6-6), POWER circuit breaker (9, fig. 6-6), and VOLUME OFF/MAX switch control (6, fig. 6-6) to OFF.

## CHAPTER 7

### PREPARATION FOR STORAGE OR SHIPMENT

**7-1. Preparation for Shipment.** Instructions for disassembling and packing the AN/GRC-213 for shipment are contained in the subparagraphs below.

- a. Disassembly Instructions. To disassemble the AN/GRC-213, perform the following steps:
- (1) Remove amplifier-power supply, with latched receiver/exciter and amplifier/coupler on top, per paragraph 6-7e, steps 1 thru 11.
  - (2) Remove AN/PRC-104A power cable from connector J104 (6, fig. 7-1), on rear of amplifier-power supply, and AN/PRC-104A power input connector (5, fig. 7-1), on rear of amplifier/coupler.
  - (3) Remove audio cable (cable will still be attached by short chain) from lower AUDIO connector (1, fig. 7-1) on receiver/exciter and RADIO AUDIO connector (4, fig. 7-1) on amplifier-power supply.
  - (4) Remove rf cable from BNC connector (2, fig. 7-1) on amplifier/coupler.
  - (5) Loosen fasteners (3, fig. 7-1) from hooks located on front of receiver/exciter and amplifier/coupler.
  - (6) Slide latched receiver/exciter and amplifier/coupler forward to disengage retaining cleats and lift from amplifier-power supply.
  - (7) Tape end connector of power cable (part of installation kit) to protect the female terminals from water and dirt.
  - (8) Remove loudspeaker from vehicle by removing two bolts (1, fig. 6-4) securing loudspeaker to vehicle.
- b. Packaging. To package the AN/GRC-213 for reshipment, proceed as follows:
- (1) Place latched receiver/exciter and amplifier/coupler in space provided in the transit case.
  - (2) Place the handset and telegraph key (if used) in the transit case.
  - (3) Replace transit case cover and fasten the four latches.
  - (4) Place remaining equipment in a standard package sufficient to provide adequate protection from shock and freight damage.

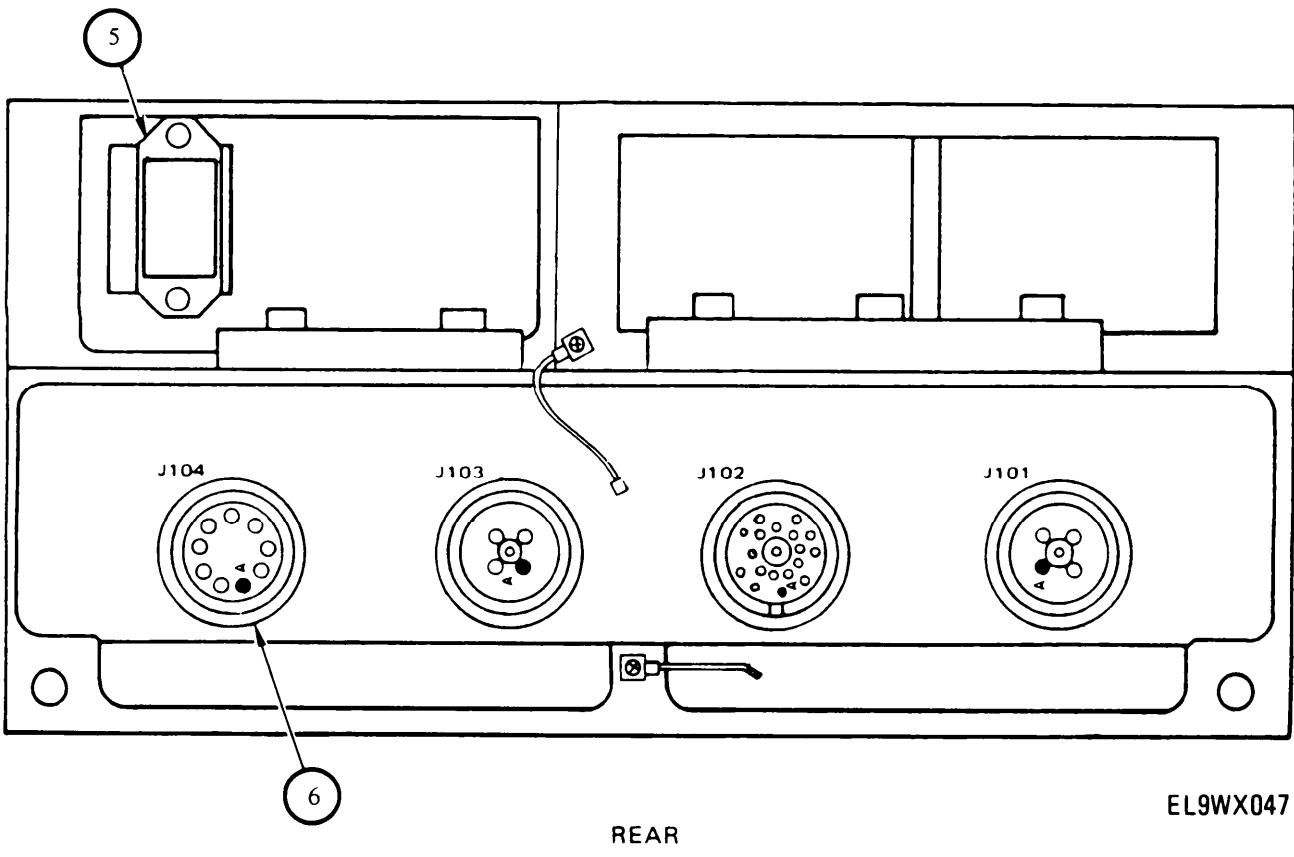
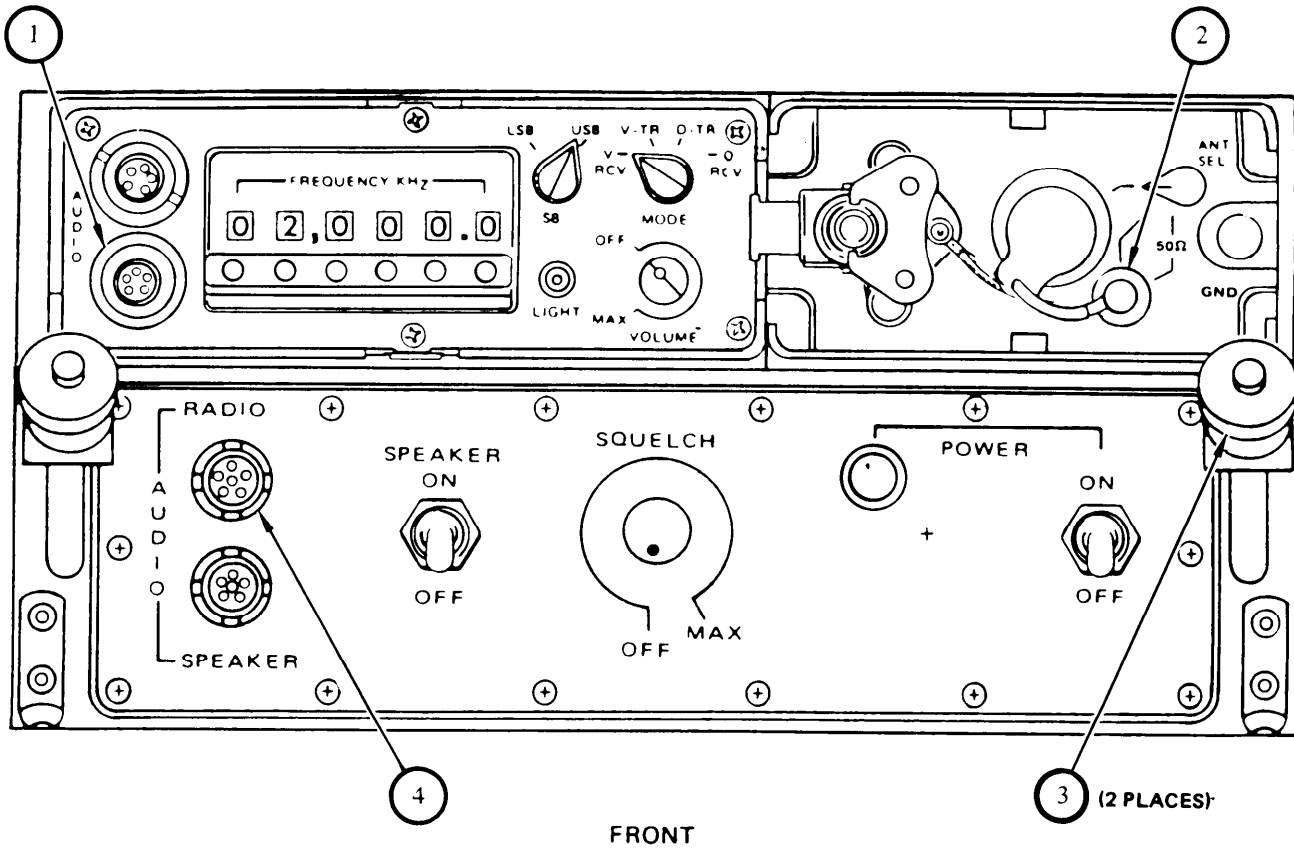

EL9WX047

Figure 7-1. Disassembly

**7-2. Storage.** The AN/GRC-213 should be stored in the best available site that will provide protection from the elements and unauthorized personnel. Covered sites are the best. If there is not enough covered space for all items, keep items covered that are most likely to be damaged by the weather. Items that cannot be covered should be stored on hard surfaces that drain well. Trucks, vans, and containers maybe used if they give the best available protection. Be sure to comply with the fire plan for fire fighting equipment and personnel.

**WARNING**

Do not store lithium battery, BA-5590/U, in transit care longer than 30 days. After 30 days, the battery may discharge, overheat, and vent hazardous sulfur dioxide fumes.

**CAUTION**

Bulk storage of lithium batteries BA-5590/U should be in a cool, well ventilated facility. Refrigeration is not required. Battery life decreases with storage time and with increasing temperature. For this reason, temperatures above 130°F should be avoided if possible.





## APPENDIX A REFERENCES

---

### A-1. Scope

This appendix lists all forms, field manuals, technical manuals, and miscellaneous publications referenced in this manual.

### A-2. Forms

DA Form 2028	Recommended Changes to Publications and Blank Forms.
DA Form 2028-2	Recommended Changes to Equipment Technical publications.
SF 361	Transportation Discrepancy Report (TDR).
SF 368	Product Quality Deficiency Report.

### A-3. Field Manuals

FM 21-11	Artificial Respiration.
FM 21-26	Map Reading.

### A-4. Technical Manuals

TM 11-2300-476-14&P	Operator's, Organizational, Direct Support and General Support Maintenance Manual (Including Repair Parts and Special Tools List) for Installation Kits, Electronic Equipment MK-2442/GRC-213, for Armored Personnel Carrier M113A1 (NSN 5820-01-189-9791); MK-2443/GRC-213, for utility Truck M151/41 (NSN 5820-01-189-9792); MK-2444/GRC-213, for Cargo Truck M561 (NSN 5820-01-189-9788); MK-2445/GRC-213, for Carrier Command Post M577A (NSN 5820-01-189-9793); MK-2446/GRC-213, for Truck M882 or M1008A1 CUCV (NSN 5820-01-189-9789); MK-2447/GRC-213, for General Purpose wheeled or Tracked Vehicles (NSN 5820-01-189-9790).
TM 11-4820-401-35-1	Direct Support, General Support, and Depot Maintenance Manual (Including Repair Parts and Special Tools Lists) for Control Frequency Selector C-2742/VRC and Control, Radio Set C-2299/VRC.

TM 11-5820-923-12

TM 11-5820-467-15 Operator, Organizational, Direct Support, General Support, and Depot Maintenance Manual, Antenna Group AN/GRA-50 (NSN 5985-00-892-0758).

TM 11-5820-919-12 Operator's and Organizational Maintenance Manual for Radio Set AN/PRC-104A (NSN 5820-01-141-7953).

TM 11-5820-919-40-1 General Support Maintenance Manual for Radio Set AN/PRC-104A (NSN 5820-01-141-7953).

TM 11-5820-919-40-2 General Support Maintenance Manual for Radio Set AN/PRC-104A (NSN 5820-01-141-7953).

TM 11-5820-923-10-HR Hand Receipt Manual Covering Content of Components of End Item (COEI), Basic Issue Items (BII), and Additional Authorization List (AAL) for Radio Set AN/GRC-213 (NSN 5820-01-128-3935).

TM 11-5820-923-20P Organizational Maintenance Repair Parts and Special Tools List for Radio Set AN/GRC-213 (NSN 5820-01-128-3935).

TM 11-5820-923-34P Direct Support and General Support Maintenance Repair Parts and Special Tools List (Including Depot Maintenance Repair Parts and Special Tools) for Radio Set AN/GRC-213 (NSN 5820-01-128-3935).

TM 11-5820-923-40 General Support Maintenance Manual for Amplifier-Power Supply AM-7152/GRC-213 (NSN 5820-01-127-5855).

TM 11-5830-340-12 Operator and organizational Maintenance Manual, intercommunication Set AN/VIC-1(V) (NSN 5830-00-856-3273); Control Intercommunication Set C-10456/VRC (NSN 5830-01-082-0804), C-10680/VRC and Amplifier, Audio Frequency, AM-7046/VRC.

TM 11-5985-379-14&P Operator's, Organizational, Direct Support, and General Support Maintenance Manual (Including Repair Parts and Special Tools List) for Antenna AS-2259/GR (NSN 5985-00-106-6130).

TM 750-244-2 Procedures for Destruction of Army Electronics Materiel to Prevent Enemy Use (Electronics Command).

#### **A-5. Miscellaneous Publications**

AMDF (AR 708-1) IAW Packaging Segment of AMDF by NSN.

AR 735-11-2 Report of Item and Packaging Discrepancies.

CTA 8-100	Army Medical Department Expendable/Durable Items.
CTA 50-970	Expendable/Durable Items (Except Medical, Class V, Repair Parts and Heraldic Items).
DA Pam 25-30	Consolidated Index of Army Publications and Blank Forms.
DA Pam 738-750	The Army Maintenance Management System (TAMMS).
SB 11-573	Painting and Preservation of Supplies Available for Field Use for Electronics Command Equipment.
SB 11-614	Caution Notice for Antenna Bases, Towers, and Other Mast Structures.
TB 43-0118	Field Instructions for Painting and Preserving Communications-Electronics Equipment.
TB 43-0129	Safety Measures to be Observed when Installing and Using Whip Antennas, Field-Type Masts, Towers, Antennas, and Metal Poles that are used with Communication, Radar and Direction Finder Equipment.



## APPENDIX B MAINTENANCE ALLOCATION CHART

### Section I. INTRODUCTION

#### B-1. General.

This appendix provides a summary of the maintenance operations for AN/GRC-213. It authorizes categories of maintenance for specific maintenance functions on repairable items and components-and the tools and equipment required to perform each function. This appendix may be used as an aid in planning maintenance operations.

#### B-2. Maintenance Functions.

Maintenance functions will delimited to and defined as follows:

a. Inspect. To determine the serviceability of an item by comparing its physical, mechanical and/or electrical characteristics with established standards through examination.

b. Test. To verify serviceability and to detect incipient failure by measuring the mechanical or electrical characteristics of an item and comparing those characteristics with prescribed standards.

c. Service. Operations required periodically to keep an item in proper operating condition, ie, to clean (decontaminate), to preserve, to drain, to paint, or to replenish fuel, lubricants, hydraulic fluids, or compressed air supplies.

d. Adjust. To maintain, within prescribed limits, by bringing into proper or exact position, or besetting the operating characteristics to the specified parameters.

e. Align. To adjust specified variable elements of an item to bring about optimum or desired performance.

f. Calibrate. To determine and cause corrections to be made or to be adjusted on instruments or test measuring and diagnostic equipments used in precision measurement. Consists of comparisons of two instruments, one of which is a certified standard of known accuracy, to detect and adjust any discrepancy in the accuracy of the instrument being compared.

g. Install. The act of emplacing, seating, or fixing into position an item, part, module (component or assembly) in a manner to allow the proper functioning of the equipment or system.

h. Replace. The act of substituting a serviceable like type part, subassembly, or module (component or assembly) for an unserviceable counterpart.

*i. Repair.* The application of maintenance services (inspect, test, service, adjust, align, calibrate, replace) or other maintenance actions (welding, grinding, riveting, straightening, facing, remachining, or resurfacing) to restore serviceability to an item by correcting specific damage, fault, malfunction, or failure in part, subassembly, module (component or assembly), end item, or system.

*j. Overhaul.* That maintenance effort (service/action) necessary to restore an item to a completely serviceable/operational condition as prescribed by maintenance standards (ie, DMWR) in appropriate technical publications. Overhaul is normally the highest degree of maintenance performed by the Army. Overhaul does not normally return an item to like new condition.

*k. Rebuild.* Consists of those services/actions necessary for the restoration of unserviceable equipment to a like new condition in accordance with original manufacturing standards. Rebuild is the highest degree of materiel maintenance applied to Army equipment. The rebuild operation includes the act of returning to zero those age measurements (hours/miles, etc) considered in classifying Army equipment/components.

**B-3. Explanation of Columns in the MAC, Sectional. II**

*a. Column (1)-Group Number.* Column 1 lists group numbers, the purpose of which is to identify components, assemblies, subassemblies, and modules with the next higher assembly,

*b. Column (2)-Component/Assembly.* Column 2 contains the noun names of components, assemblies, subassemblies, and modules for which maintenance is authorized.

*c. Column (3)-Maintenance Function.* Column 3 lists the functions to be performed on the item listed in column 2. When items are listed without maintenance functions, it is solely for the purpose of having the group numbers in the MAC and RPSTL coincide.

*d. Column (4)-Maintenance Category.* Column 4 specifies, by the listing of a "work time" figure in the appropriate subcolumn(s), the lowest level of maintenance authorized to perform-the function listed in column 3. This figure represents the active time required to perform that maintenance functional the indicated category of maintenance. If the number or complexity of the tasks within the listed maintenance function varies at different maintenance categories, appropriate "work time" figures will be shown for each category. The number of task-hours specified by the "work time" figure represents the average time required to restore an item (assembly, subassembly, component, module, end item, or system) to a serviceable condition under typical field operating conditions. This time includes preparation time, troubleshooting time, and quality assurance/quality control time in addition to the time required to perform the specific tasks identified for the maintenance functions authorized in the maintenance allocation chart. Subcolumns of column 4 areas follows:

C . . . . .	Operator/Crew
O . . . . .	Organizational
F . . . . .	Direct Support
H . . . . .	General Support
D . . . . .	Depot

e. Column (5)-Tools and Equipment. Column 5 specifies by code those common tool sets (not individual tools) and special tools, test, and support equipment required to perform the designated function.

f. Column (6)-Remarks. Column 6 contains an alphabetic code which leads to the remark in section IV, Remarks, which is pertinent to the item opposite the particular code.

#### **B-4. Explanation of Columns in Tool and Test Equipment Requirements, Section III.**

a. Tool or Test Equipment Reference Code. The numbers in this column coincide with the numbers used in the tools and equipment column of the MAC. The numbers indicate the applicable tool or test equipment for the maintenance functions.

b. Maintenance Category. The codes in this column indicate the maintenance category allocated the tool or test equipment.

c. Nomenclature. This column lists the noun name and nomenclature of the tools and test equipment required to perform the maintenance functions.

d. National/NA TO Stock Number. This column lists the National/NATO stock number of the specific tool or test equipment.

e. Tool Number. This column lists the manufacturer's part number of the tool followed by the Federal Supply Code for manufacturers (5-digit) in parentheses.

#### **B-5. Explanation of Columns in Remarks, Section IV.**

a. Reference Code. This code refers to the appropriate item in section II, column 6.

b. Remarks. This column provides the required explanatory information necessary to clarify items appearing in section II.

**SECTION II MAINTENANCE ALLOCATION CHART  
FOR  
AN/GRC-213**

(1) GROUP NUMBER	(2) COMPONENT/ASSEMBLY	(3) MAINTENANCE FUNCTION	(4) MAINTENANCE CATEGORY					(5) TOOLS AND EQPT	(6) REMARKS
			C	O	F	H	D		
00	Radio Set, AN/GRC-213 (Basic Unit)	Install		0.3				13	A
		Service	1.1						
		Inspect	0.1						
		Test	0.2						B
		Test		0.3				1,9,10,11	c
01	Radio Set, AN/PRC-104A	Repair		0.2				1,9,10,11, 13	E,G
		Service	0.2						
		Inspect	0.2						
		Test	0.2						B
		Test		0.2				1,9,10,11	c
0101	Receiver-Transmitter, RT-1209/URC	Repair		0.2				1,9,10,11	E,H
		Service	0.1		0.1				
		Inspect	0.1						
		Test				0.4		1,2,7-12, 14	M
		Repair				0.4		1,2,7-12, 14	F,J,Q
010101	Housing, RT Assembly	Overhaul					2.5	1-11,14,20	K
		Replace				0.3		12	
		Test					0.5	1	M, K
		Repair					0.8	1,2,7-12, 14	F,J,K
		01010101	PTD Ca Assembly Flex	Replace					0.6
Test							0.4	1	D, K
Repair							0.4	1,12,19	F, J, K
010102	Harmonic Filter Assembly	Replace				0.1		12	
		Test					0.3	1,3-11,12, 14, 20	D, K
		Repair					0.4	1,2,7-12, 14,19	J, K
		Aline					0.1	1,7-11,14, 20	K
		010103	Modulator/Demodulator Assembly	Replace				0.1	
Test							1.0	1-11,14-16, 20	D, K
Repair							0.4	1,2,7-12, 14,19	F, J, K
Aline							0.1	1-11,12,14, 15,16,20	K
01010301	First Frequency Converter Submodule	Replace					0.1	12	
		Test					0.2	1,3-8,14,20	D, K
		Repair					0.4	1,2,7-12,14 19	J, K
01010302	Second Frequency Converter Submodule	Replace					0.1	12	
		Test					0.3	1,3-8,14,20	D, K
		Repair					0.4	1,2,7-12,14 19	J, K



SECTION II MAINTENANCE ALLOCATION CHART  
FOR  
AN/GRC-213

(1) GROUP NUMBER	(2) COMPONENT/ASSEMBLY	(3) MAINTENANCE FUNCTION	(4) MAINTENANCE CATEGORY					(5) TOOLS AND EQPT.	(6) REMARKS
			C	O	F	H	D		
01010303	Third Frequency Converter Submodule	Replace					0.1	12	
		Test					0.3	1,3-8,14, 20	D, K
		Repair					0.4	1,2,7-12, 14,19	J, K
010104	Synthesizer Assembly	Replace				0.1		12	
		Test					0.8	1,3-6,8-11, 14,15,17, 20	D, K
		Repair					0.4	1,2,7-12, 14,19	J, K
		Aline					0.1	1,3-6,8-11, 14,15,17, 20	K
010105	Control Panel Assembly	Replace				0.1		12	
		Test					0.2	1,8,14	D, K
		Repair					0.4	1,2,7-11, 12,14,19	F, J, K
010106	Power Supply Assembly	Replace				0.1		12	
		Test					0.7	1,8,9-11, 14,20	D, K
		Repair					0.4	1,2,7-11, 12,14,19	J, K
		Aline					0.1	1,8,12,14, 20	K
0102	Amplifier, Radio Frequency, AM-6874/PRC-104	Replace		0.1					
		Service	0.2						
		Inspect	0.2						
		Test				0.1		1,8-12,14	M
		Repair				0.2		1,8-12,14	F, J
010201	RF Amplifier Assembly	Overhaul					2.5	1,8-12,14, 20	K
		Replace				0.1		12	
		Test					0.5	1	D, K
010202	Power Amplifier Module Assembly	Repair					0.2	1,8-12,14, 20	J, K
		Replace				0.4		12	
		Test					0.9	1,3-11,14, 15,20	D, K
01020201	Amplifier, Power Top CCA	Repair					0.2	1,8-12,14, 19	F, J, K
		Aline					0.1	1,3-12,14, 15,20	K
		Replace					0.4	13	
01020201	Amplifier, Power Top CCA	Test					0.9	1,3-11,14, 15,20	D, K
		Repair					0.2	1,8-12,14, 19	J, K
01020202	Amplifier, Power Bottom CCA	Replace					0.4	12	
		Test					0.9	1,3-11,14, 15,20	D, K

**SECTION II MAINTENANCE ALLOCATION CHART  
FOR  
AN/GRC-213**

(1) GROUP NUMBER	(2) COMPONENT/ASSEMBLY	(3) MAINTENANCE FUNCTION	(4) MAINTENANCE CATEGORY					(5) TOOLS AND EQPT	6 REMARKS	
			C	O	F	H	D			
01020202	Amplifier, Power Bottom CCA (Continued)	Repair					0.2	1,8-12,14, 19	J,K	
010203	Antenna Tuner Module Assembly	Replace				0.1		12		
		Test					0.7	1,7-11,14, 15,20	D,K	
		Repair					0.2	1,8-12,14, 19	F,J,K	
		Aline					0.1	1,7,8,12,14 20	K	
01020301	Tuner, Antenna Top CCA	Replace					0.4	12		
		Test					0.7	1,7-11,14, 15,20	D,K	
		Repair					0.2	1,8-12,14, 19	J,K	
01020302	Tuner, Antenna Bottom CCA	Replace					0.4	12		
		Test					0,7	1,7-11,14, 15,20	D,K	
		Repair					0.2	1,8-12,14, 19	J,K	
0103	Case, Radio Set, CY-8291/PRC-104(V)	Replace		0.1						
		Repair				0.3		12,21		
0104	Antenna, AS-2259/GR	Repair		0.1					N	
0105	Antenna Group, AN/GRA-50	Repair		0.1					O	
0106	Battery, Storage, BB-590/U	Replace	0.1							
		Service		0.3				18	L	
02	Amplifier - Power Supply, AM-7152/GRC-213	Replace		0.1						
		Service								
		Inspect	0.1							
		Test	0.1				0.9	1,7,8,9,10, 11,14,	M	
		Repair					0.8	1,7,8,9,10, 11,12,14	F,J	
		Repair						3.0	12,19,1,7, 8,9,10,11, 14	P
		Overhaul						3.0	1,7,8,9,10, 11,12,14	K
0201	Control Panel	Replace					0.1	12		
		Test					0.7	1	M	
		Repair					0.8	1,12	F,J	
0202	Amplifier/Squelch CCA	Replace				0.1		12		
		Test						1.0	1,7,8,9, 10,11,12, 14,15	D,K
		Repair						0.8	1,7,8,9,10, 11,12,14, 19	J,K

SECTION II MAINTENANCE ALLOCATION CHART  
FOR  
AN/GRC-213

(1) GROUP NUMBER	(2) COMPONENT/ASSEMBLY	(3) MAINTENANCE FUNCTION	(4) MAINTENANCE CATEGORY					(5) TOOLS AND EQPT.	(6) REMARKS
			C	O	F	H	D		
0203	Card Cage Assembly	Replace				0.2		12	
		Test				0.3		1,7,8,9,10 11,14	M
		Repair				0.8		1,7,8,9,10 11,12,14, 19	F,J
020301	Veh Intercom-1 CCA	Replace				0.2		12	
		Test					1.0	1,7,8,9,10 11,12,14, 15	D, K
		Repair					0.8	1,7,8,9,10 11,12,14, 19	J, K
020302	Power Conditioner CCA	Replace				0.2		12	
		Test					1.0	1,7,8,9,10 11,12,14, 15	D, K
		Repair					0.8	1,7,8,9,10 11,12,14, 19	J, K

SECTION III TOOL AND TEST EQUIPMENT REQUIREMENTS

AN/GRC-213

TOOL OR TEST EQUIPMENT REF CODE	MAINTENANCE CATEGORY	NOMENCLATURE	NATIONAL/NATO STOCK NUMBER	TOOL NUMBER
1	O,H,D	Multimeter, AN/PSM-45	6625-01-139-2512	
2	H,D	Generator, Signal, SG-1171 U/U	6625-01-133-6160	
3	D	Spectrum Analyzer, Mainframe, IP-1216 (T)/GR	6625-00-424-4370	
4	D	--Spectrum Analyzer, IF Section, PL-1388/U	6625-00-431-9339	
5	D	--Spectrum Analyzer, RF Section, PL-1399/U	6625-00-432-5055	
6	D	--Spectrum Analyzer, Tracking Generator, SG-1122/U	6625-00-155-5990	
7	H,D	RF Signal Generator, SG-1144/U	6625-01-075-8478	
8	H,D	DC Power Supply, PP-2309 C/U	6130-01-139-2514	
9	O,H,D	Test Set, Radio Frequency Power, AN/USM-298	6625-00-880-5119	
10	O,H,D	Detecting Element, 50H	6625-00-945-6092	
11	O,H,D	Dummy Load, 8085	5985-00-477-8165	
12	H,D	Tool Kit, Electronic Equipment, TK-105/G	5180-00-610-8177	
13	O	Tool Kit, Electronic Equipment, TK-101/G	5180-00-064-5178	
14	H,D	Kit, Group, Electrical, OA-9161/GRC-213:  --Receiver/Transmitter, RT-1209/URC, 755002A0150  --Amplifier, RF, AM-6874/PRC-104, 755002A0550  --Handset, H-250A/U  --Cable Assembly, Electrical Power, CX-13030/PRC-104, 755002A1255 --Audio Input/Keying, Adapter, 755002B9400 --Amplifier Power Supply, AM-7152/GRC-213, 755002B9100 --Adapter, Whip, 755002B9410 --Mount, Electrical Equipment, MT-6234/GRC-213 --Cable Assembly, RF, 55002B9017  --Cable Assembly, Audio, 755002B9018	5820-01-159-1646  5820-01-069-2368  5820-01-065-5044  5965-00-043-3463  5995-00-G98-4845  5995-00-G98-4846	

SECTION II TOOL AND TEST EQUIPMENT REQUIREMENTS  
FOR

TOOL OR TEST EQUIPMENT REF CODE	MAINTENANCE CATEGORY	NOMENCLATURE	NATIONAL/NATO STOCK NUMBER	TOOL NUMBER
		--Cable Assembly, Conditioned Power, 755002B9019	5995-00-G98-4847	
		--Attenuator, Step, CN-1128/U	5985-00-957-1860	
		--Attenuator, Coaxial, NARDA 765-20		
		--Technical Manual		
		--Loudspeaker LS-454/U		
		--DC Power Cable, CX-4720-10FT		
		--Extender Cable, AM-7152 Power Conditioner CCA, 755002B9431		
		--Extender Cable, AM-7152 VIC-1 CCA, 75500269432		
		--Extender Cable, AM-7152 Amplifier/Squelch CCA, 755002B9432		
15	D	Oscilloscope, OS-261C(V)1/U	6625-01-119-7314	
16	D	Distortion Analyzer, AN/URM-184A	6625-00-802-8718	
17	D	Frequency Counter, AN/USM-459	6625-01-061-8928	
18	0	Battery Charger, PP-6241/U	6130-00-106-6445	
19	D	Bench Repair Center, PRC-350C	4940-00-403-8176	
20	D	Depot Accessories Kit, 755002B9139:		
		--Modulator/Demodulator Test Extender Cable, 755002B9420		
		--RF Coaxial Cable, 75500269425		
		--RF Extender Cable, 755002B9430		
		--Frequency Converter Test Bed A1A1A1, 755002B9440		
		--Frequency Converter Test Bed A1A1A2, 755002B9450		
		--Frequency Converter Test Bed A1A1A3, 755002B9460		
		--Harmonic Filter/Power Amplifier Test Extender Cables, 755002B9435		
		--Synthesizer Test Extender Cable, 755002B9470		
		--Antenna Tuner Extender Cable, 755002B9480		
		--Adapter, Whip, 755002B9411		
		--Probe, High Impedance, HP Model No. 1121A, 755002B9495		
		--100 Ohm Load, 755002B9475		
		--130 Ohm Load, 755002B9490		
		Dent Filler	8010-00-926-2135	
		--Synthetic Resin	8040-00-266-0815	

SECTION III TOOL AND TEST EQUIPMENT REQUIREMENTS  
FOR  
AN/GRC-213

TOOL OR TEST EQUIPMENT REF CODE	MAINTENANCE CATEGORY	NOMENCLATURE	NATIONAL NATO STOCK NUMBER	TOOL NUMBER
		<p><b>NOTE</b></p> <p>All equipment defined in this section (III) may be substituted with equivalent items. Each maintenance shop should evaluate its current equipment available against its requirements.</p>		

SECTION IV. REMARKS

REFERENCE CODE	REMARKS
A	See paragraph 2-2 in "Preparation for Use and Installation Instructions", chapter in TM 11-5820-923-12.
B	Operational Test
C	Test required to fault isolate defective RT-1209, AM-6874, AM-7152, SA-2365 assemblies/components or wiring problems
D	Test required to fault isolate defective modules, circuit cards, or wiring problems
E	Repair is accomplished by replacement of assemblies/components or cable assemblies
F	Repair is accomplished by replacement of modules, circuit cards, or cable assemblies
G	This task can include the replacement of non-repairable assemblies (RF Cable assembly 755002B9017, Audio Cable Assembly 755002B9018, Power Cable Assembly 755002B9019, Loudspeaker LS-454).
H	This task can include the replacement of non repairable assemblies (Cable Assembly CG-3815/U; Adapter UG-349/U; Battery Extender Cable Assembly CX-13031, Antenna Spring AB-129/PR, Frame Pack Field, Pack Shelf, Cargo Shelf, Handset H250/U, Battery Case CY-7875, Antenna Base AB-1241, Telegraph Key KY-872/PRC-104, Whip Antenna AT-271, Primary Battery BA-590/U, Cargo Strap Tie-Down, Charger Cable Assembly).
I	This task involves removing either the RT-1209 or AM-6874 from either the AN/GRC-213 or AN/PRC-104A
J	This task can include the replacement of a nonrepairable assembly/piece part
K	This task will be performed by USMC Depot, Albany, Georgia
L	This task includes the replacement or bringing current chemical levels within specified standards. See TM11-5820-919-12
M	Test required to fault isolate to defective modules, circuit cards, or wiring problems.
N	See TM 11-5985-379-148P for maintenance allocation
O	See TM 11-5820-467-15 for maintenance allocation
P	This task involves the replacement of the AM-7152 housing by the USMC Depot, Albany Georgia
Q	Although the replacement of fuse (F-1) is performed at GSM, the configuration drawings identify this item as Dart of FGC 01010101.





## APPENDIX C OF END ITEM AND BASIC ISSUE ITEMS LISTS

### Section I. INTRODUCTION

#### C-1. Scope.

This appendix lists integral components of and basic issue items for the Radio Set AN/GRC-213 to help you inventory items required for safe and efficient operation.

#### C-2. General.

This Components of End Item List is divided into the following sections:

a. Section II. Integral Components of the End Item. These items, when assembled, comprise the Radio Set AN/GRC-213 and must accompany it whenever it is transferred or turned in. The illustrations will help you identify these items.

b. Section III. Basic Issue Items. These are the minimum essential items required to place the Radio Set AN/GRC-213 in operation, to operate it, and to perform emergency repairs. Although shipped separately packed they must accompany the Radio Set AN/GRC-213 during operation and whenever it is transferred between accountable officers. The illustrations will assist you with hard-to-identify items. This manual is your authority to requisition replacement BII, based on TOE/MTOE authorization of the end item.

#### C-3. Explanation of Columns.

a. Illustration Number. Indicates the number of the illustration in which the item is shown.

b. National Stock Number. Indicates the National stock number assigned to the item and which will be used for requisitioning.

c. Description. Indicates the Federal item name and, if required, a minimum description to identify the item. The physical location of each item follows the description in this column. The lists are designed to inventory all items in one area of the major item before moving onto an adjacent area.

d. FSCM and Part Number. Indicates the primary number used by the manufacturer, which controls the design and characteristics of the item by means of its engineering drawings, specifications, standards, and inspection requirements to identify an item or range of items. Preceding the part number, the Federal Supply Code for Manufacturers (FSCM) is shown in parentheses. If the item you require differs between serial numbers of the same model, effective serial numbers are shown in the last line of the description. If item required differs for different models of this equipment, the model is shown under the "Usable On" heading in the description column. These codes are identified in paragraph e.

e. Usable on Code. "USABLE ON" codes, when included, help you identify which component items are used on the different models. Identification of the codes used in these lists are:

<u>Code</u>	<u>Used On</u>
PAA	Armored Personnel Carrier M113A1
PAB	Utility Truck M151A1
PAC	Cargo Truck M561
PAD	Carrier Command Post M577A1
PAE	Truck M882 or M1008A1 CUCV
PAF	General Purpose Wheeled or Tracked Vehicles

f. Unit of Measure (U/M). Indicates the measure used in performing the actual operational/maintenance function. This measure is expressed by a two-character alphabetical abbreviation (for example, ea, in., pr).

g. Quantity Required (Qty Reqd). This column lists the quantity of each item required for a complete major item.

**Section II. COMPONENTS OF END ITEM**

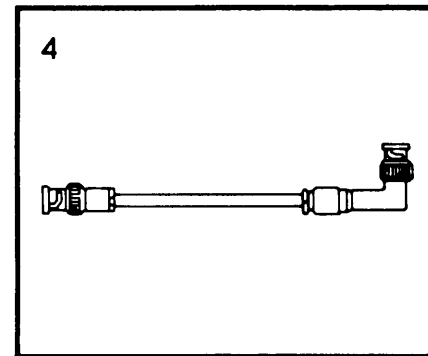
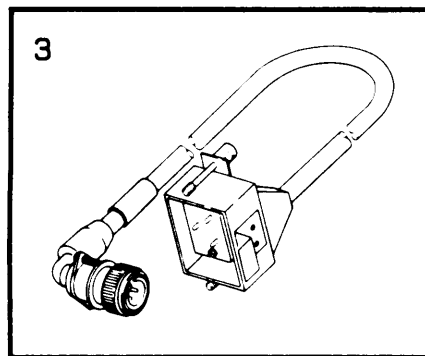
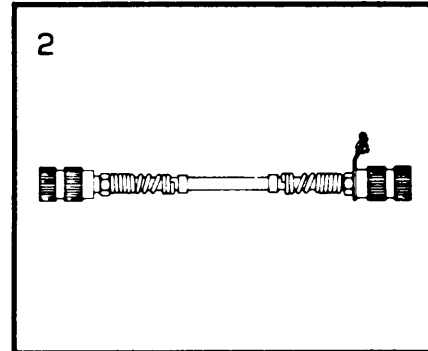
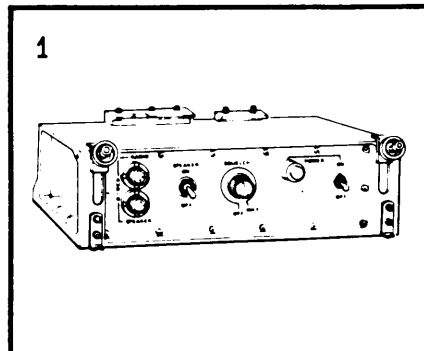

(1) Illus Number	(2) National Stock Number	(3) Description FSCM and Part Number	USABLE ON CODE	(4) U/M	(5) Qty Reqd
1	5820-01-127-5855	AMPLIFIER-POWER SUPPLY (on mounting base) (80058) AM-7152/GRC-213		EA	1
2	5995-01-219-9441	CABLE ASSEMBLY, AUDIO (between amplifier-power supply and receiver/exciter) (87990) 75500269018		EA	1
3	5995-01-219-9516	CABLE ASSEMBLY, CONDITIONED POWER (between amplifier-power supply and amplifier/coupler) (87990) 75500269019		EA	1
4	5995-01-213-5188	CABLE ASSEMBLY, RF (between switching unit and amplifier/coupler) (87990) 75500269017		EA	1

Section II. COMPONENTS OF END ITEM (Cent)

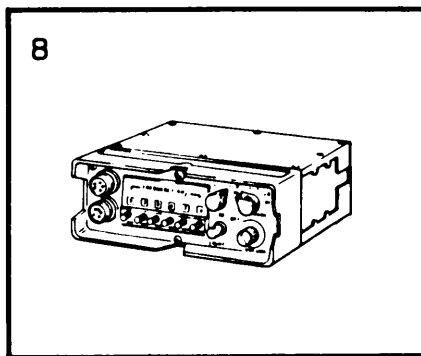
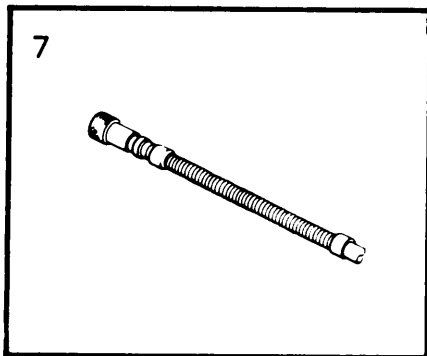
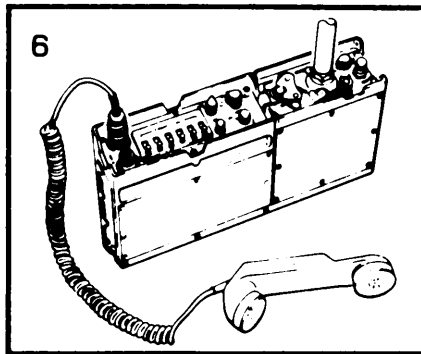
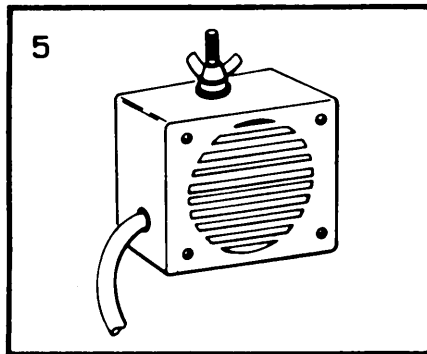

(1) Illus Number	(2) National Stock Number	(3) Description FSCM and Part Number	USABLE ON CODE	(4) U/M	(5) Qty Reqd
5	5965-00-876-2375	LOUDSPEAKER (connected to amplifier- power supply) (81349) LS454/U		EA	1
6	5820-01-141-7953	RADIO SET (on top of amplifier-power supply) (80058) AN/PRC-104A		EA	1
7	5935-00-739-2242	ADAPTER (in transit case) (80058) UG-349A/U		EA	1
8	5820-01-065-5044	AMPLIFIER, RF (connected to receiver/ exciter) (80058) AM-6874/PRC-104		EA	1

Section II. COMPONENTS OF END ITEM (Cont)

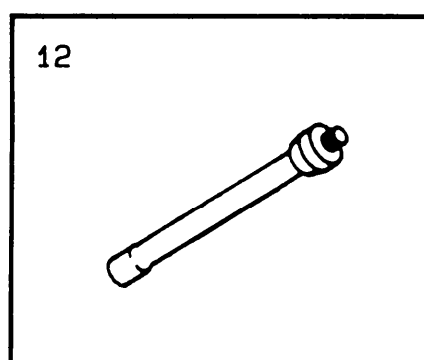
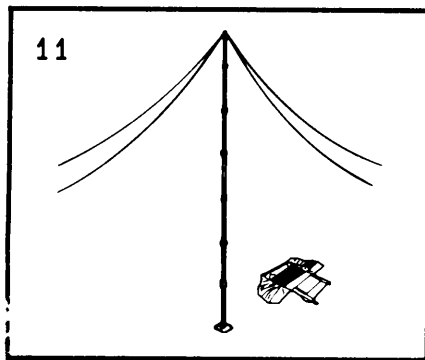
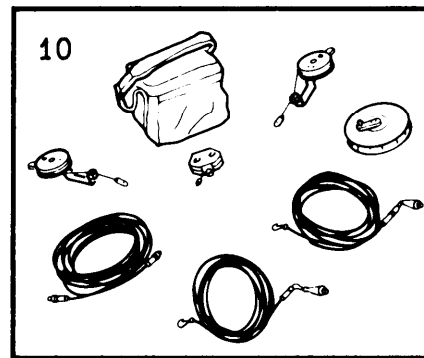
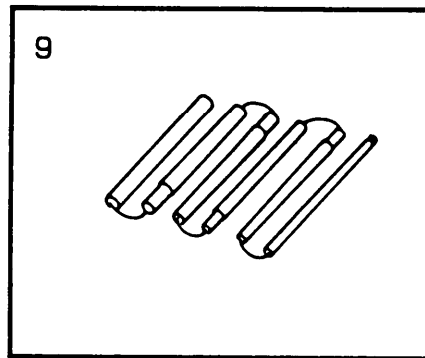

(1) Illus Number	(2) National Stock Number	(3) Description FSCM and Part Number	USABLE ON CODE	(4) U/M	(5) Qty Reqd
9	5985-00-646-2365	ANTENNA, WHIP (in transit case) (80058) AT-271A/PR C		EA	1
10	5985-00-892-0758	ANTENNA GROUP (in bag) (80058) AN/GRA-50		EA	1
11	5985-00-106-6130	ANTENNA (NVIS) (in roll pack) (80058) AS-2259/GR		EA	1
12	5820-00-234-4127	ANTENNA, SPRING SECTION (in transit case) (80058) AB-129/PR		EA	1

**Section II. COMPONENTS OF END ITEM (Cont)**

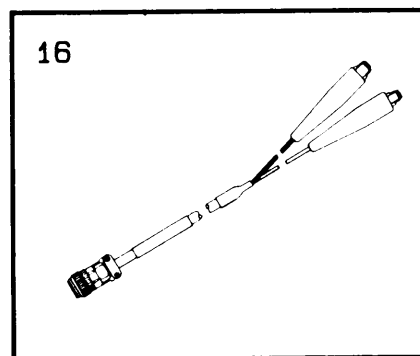
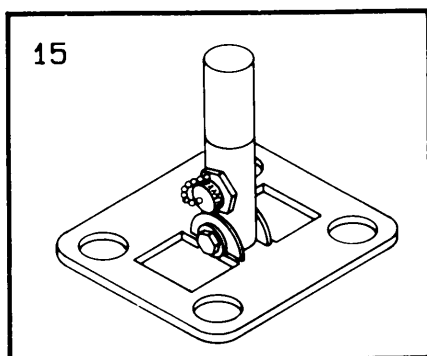
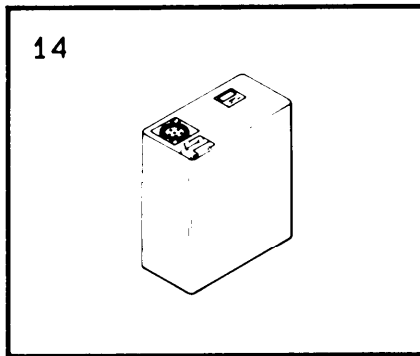
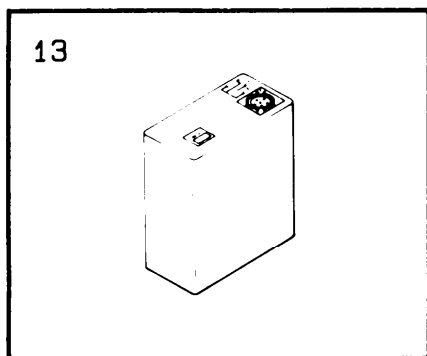

(1) Illus Number	(2) National Stock Number	(3) Description FSCM and Part Number	(4) USABLE ON CODE	(5) Qty Reqd
13	6135-01-036-3495	BATTERY, PRIMARY (in battery pack in transit case) (80058) BA-5590/U	EA	1
14	6140-01-063-3918	BATTERY, STORAGE (in battery pack in transit case) (80058) BB-590/U	EA	1
15	5820-01-065-4495	BASE, ANTENNA GROUND (in transit case) (87990) A3023292	EA	1
16	5935-00-231-3180	CABLE ASSY, CHARGER (in transit case) (01365) 79A5029A0050	EA	1

**Section II. COMPONENTS OF END ITEM (Cont)**

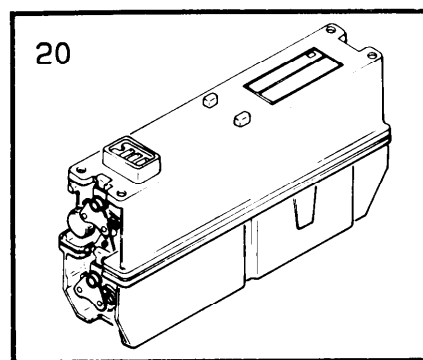
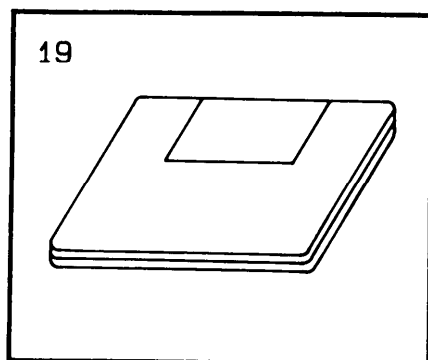
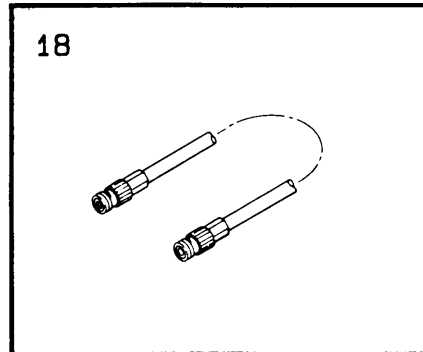
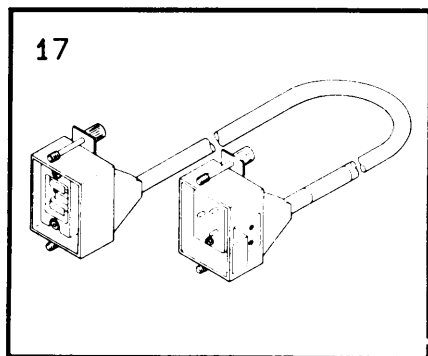

(1) Illus Number	(2) National Stock Number	(3) Description FSCM and Part Number	(4) USABLE ON CODE U/M	(5) Qty Reqd
17	5820-01-065-4442	CABLE ASSY, POWER (in transit case) (87990) 755002A1260	EA	1
18	5995-00-405-9097	CABLE ASSY, RF (in transit case) (05276) 2249-C-22	EA	1
19		CARD, INSTRUCTION (in transit case) (87990) 755002B9020	EA	1
20	6135-01-080-2886	CASE, BATTERY (in transit case) (01365) 79A5029A0000	EA	1

**Section II. COMPONENTS OF END ITEMS (Cont)**

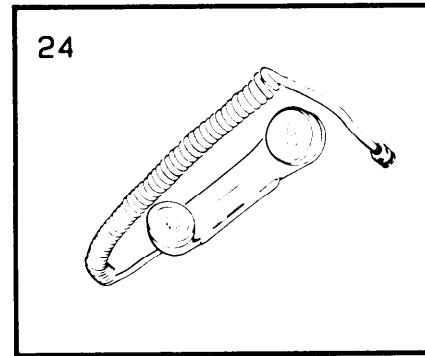
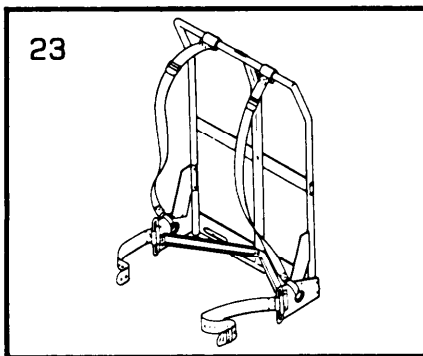
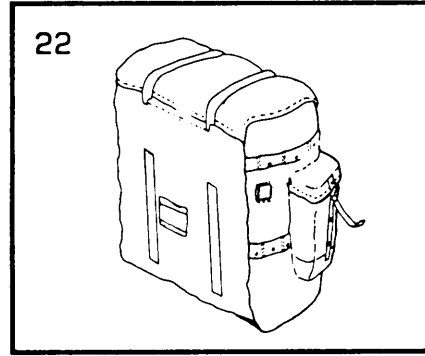
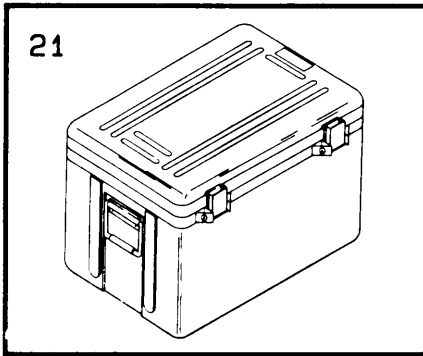

(1) Illus Number	(2) National Stock Number	(3) Description FSCM and Part Number	(4) USABLE ON CODE U/M	(5) Qty Reqd
21	5820-01-214-8802	CASE, TRANSIT (in vehicle) (24995) 431-6379	EA	1
22	8465-01-019-9102	FIELD PACK, COMBAT (in vehicle) (81337) 2-2-344	EA	1
23	8465-00-001-6475	FRAME, PACK (in vehicle, to be worn on back of soldier) (81337) 2-3-290	EA	1
24	<b>5965-00-043-3463</b>	HANDSET (connected to receiver/exciter) <b>(80058) H-250A/U</b>	EA	1



Section II. COMPONENTS OF END ITEMS (Cont)

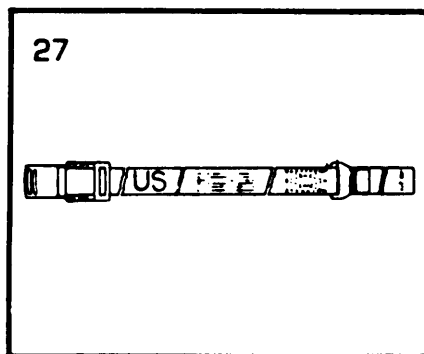
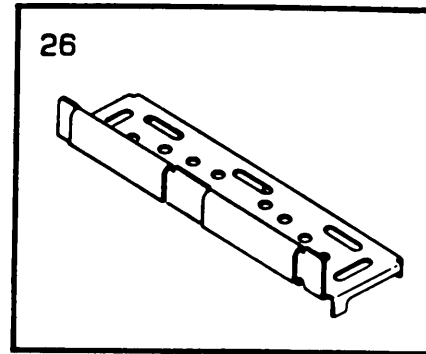
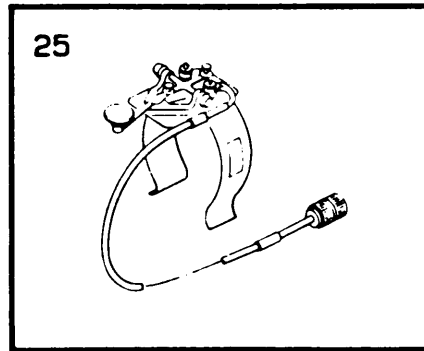

(1) Illus Number	(2) National Stock Number	(3) Description FSCM and Part Number	(4) USABLE ON CODE U/M	(5) Qty Reqd
25	5805-01-067-5368	KEY, TELEGRAPH (in transit case) (87990) 755002A1000	EA	1
26	8465-00-001-6476	SHELF, CARGO (within frame) (81337) 2-3-291	EA	1
27	8465-00-001-6477	STRAP, WEBBING (in vehicle) (81337) 2-2-313	EA	1

### Section III. BASIC ISSUE ITEMS

#### NOTE

Illustration 1 shows a typical electrical equipment installation kit. Only one installation kit is required for use of the AN/GRC-213 in your vehicle. The USABLE ON CODE column indicates the type of vehicle(s) each kit is used in. For a list of items and an illustration of each item comprising a particular installation kit, refer to appendix B section II in TM 11-2300-476-14&P.

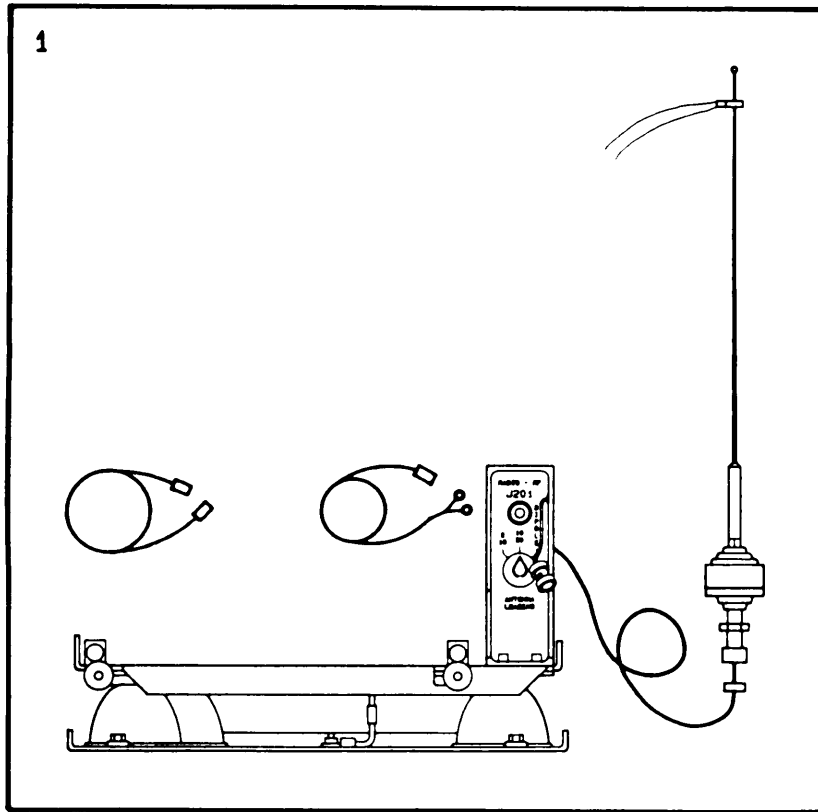

(1) Illus Number	(2) National Stock Number	(3) Description FSCM and Part Number	USABLE ON CODE	(4) U/M	(5) Qty Reqd
1	5820-01-189-9791	ELECTRONIC EQUIPMENT INSTALLATION KIT (armored personnel carrier M113A1) (80058) MK-2442/ GRC-213	PAA	EA	1
1	5820-01-189-9792	ELECTRONIC EQUIPMENT INSTALLATION KIT (utility truck M151A1) (80058) MK-2443/GRC-213	PAB	EA	1
1	5820-01-189-9788	ELECTRONIC EQUIPMENT INSTALLATION KIT (cargo truck M561) (80058) MK-2444/GRC-213	PAC	EA	1
1	5820-01-189-9793	ELECTRONIC EQUIPMENT INSTALLATION KIT (carrier command post M577A1) (800580 MK-2445/GRC-213	PAD	EA	1
1	5820-01-189-9789	ELECTRONIC EQUIPMENT INSTALLATION KIT (truck M882 or M1008A1 CUCV) (80058) MK-2446/GRC-213	PAE	EA	1
1	5820-01-189-9790	ELECTRONIC EQUIPMENT INSTALLATION KIT (general purpose wheeled or tracked vehicle) (80058) MK-2447/GRC-213	PAF	EA	1
1		TM 11-5820-923-12		EA	1



**APPENDIX D**  
**ADDITIONAL AUTHORIZATION LIST**  
**Section I. INTRODUCTION**

**D-1. Scope.**

This appendix lists additional items you are authorized for the support of the Radio Set AN/GRC-213.

**D-2. General.**

This list identifies items that do not have to accompany the Radio Set AN/GRC-213 and that do not have to be turned in with it. These items are all authorized to you by CTA, MTOE, TDA, or JTA.

**D-3. Explanation of Listing.**

National stock numbers, descriptions, and quantities are provided to help you identify and request the additional items you require to support this equipment. The items are listed in alphabetical sequence by item name under the type document (ie, CTA, MTOE, TDA, or JTA) which authorizes the item(s) to you.

**Section II. ADDITIONAL AUTHORIZATION LIST**

(1) National Stock Number	(2) Description  Usable on Code FSCM & Part Number	(3) U/M	(4) Qty Auth
6130-00-106-6445	Battery Charger (80058) PP-6241/U	EA	1
5820-01-159-1646	General Support Maintenance Kit, Group Electrical, OA-9161/GRC-213:	EA	1
5820-01-069-2368	Receiver/Transmitter, RT-1209/URC, 755002A0150	EA	1
5820-01-065-5044	Amplifier, RF, AM-6874/PRC-104, 75500A0550	EA	1
5965-00-043-3463	Handset, H-250A/U	EA	1
5820-01-065-8131	Cable Assembly, Electrical Power, CX-13030/PRC-104, 755002A1255	EA	1
	AudioInput/Keying, Adapter, 755002B9400	EA	1
	Amplifier Power Supply, AM-7152/ GRC-213, 755002B9100	EA	1
	Adapter, Whip, 755002B9410	EA	1
5995-01-213-5188	Mount, Electrical Equipment, MT-6234/GRC-213	EA	1
5995-01-219-9441	Cable Assembly, RF, 755002B9017	EA	1
5995-01-219-9516	Cable Assembly, Audio, 755002B9018	EA	1
	Cable Assembly, Conditioned Power 755002B9019	EA	1
	Loudspeaker LS-454/U	EA	1
	DC Power Cable, CX-472010F	EA	1
	Extender Cable, AM-7152 Power Conditioner CCA, 755002B9431	EA	1
	Extender Cable, AM-7152 VIC-1 CCA, 75500209432	EA	1
	Extender Cable, AM-7152 Amplifier/ Squelch CCA, 755002B9432	EA	1

## APPENDIX E EXPENDABLE/DURABLE SUPPLIES AND MATERIALS LIST

### Section I. INTRODUCTION

#### E-1. Scope.

This appendix lists expendable/durable supplies and materials you will need cooperate and maintain the Radio Set AN/GRC-213. This listing is for informational purposes only and is not authority to requisition the listed items. These items are authorized to you by CTA 50-970, Expendable/Durable Items (Except Medical, Class V, Repair Parts, and Heraldic Items), or CTA 8-100, Army Medical Department Expendable/Durable Items.

#### E-2. Explanation of Columns.

a. **Column (1) - Item Number.** This number is assigned to the entry in the listing and is referenced in the narrative instructions to identify the material (e. g., "Use cleaning compound (item 5, Appx E)").

b. **Column (2) - Level.** This column identifies the lowest level of maintenance that requires the listed item.

- C - Operator/Crew
- O - Organizational Maintenance
- F - Direct Support Maintenance
- H - General Support Maintenance

c. **Column (3) - National Stock Number.** This is the National stock number assigned to the item; use it to request or requisition the item.

d. **Column (4) - Description.** Indicates the Federal item name and, if required, a description to identify the item. The last line for each item indicates the part number followed by the Federal Supply Code for Manufacturer (FSCM) in parentheses, if applicable.

e. **Column (5) - Unit of Measure (U/M).** Indicates the measure used in performing the actual maintenance function. This measure is expressed by a two-character alphabetical abbreviation (eg, ea, in., pr). If the unit of measure differs from the unit of issue, requisition the lowest unit of issue that will satisfy your requirements.

**Section II. EXPENDABLE/DURABLE SUPPLIES AND MATERIALS LIST**

<b>(1) Item Number</b>	<b>(2) Level</b>	<b>(3) National Stock Number</b>	<b>(4) Description</b>	<b>(5) U/M</b>
1	C	7920-00-178-8315	Brush, Bristle, 2 3/4" long	ea
2	C		Brush, Paint	ea
3	C	8305-00-267-3015	Cheesecloth (81348)	yd
4	C	6850-00-105-3084	Cleaning Compound (solvent), Trichlorotrifluorethane	oz
5	C	7930-01-055-6121	Detergent, GP, Liq	gl
6	C		Paint, Enamel, (color 27875C1, CMPSN, TT-E-529)	gl
7	C		Paint, Epoxy (type 1, green 24052, MIL-C-22750)	gl
8	C		Paint, Primer, (type 1, kit, MIL-P-23377)	gl
9	C	5350-00-264-3485	Sandpaper, PP-105	sh
10	C		Tape, Masking (8135)	ea



RECOMMENDED CHANGES TO EQUIPMENT TECHNICAL PUBLICATIONS



THEN... JOT DOWN THE DOPE ABOUT IT ON THIS FORM. CAREFULLY TEAR IT OUT. FOLD IT AND DROP IT IN THE MAIL!

SOMETHING WRONG WITH THIS PUBLICATION?

FROM (PRINT YOUR UNIT'S COMPLETE ADDRESS)

Commander  
Stateside Army Depot  
ATTN: AMSTA-US  
Stateside, N.J. 07703-5007

DATE SENT

10 July 1975

PUBLICATION NUMBER

TM 11-5840-340-12

PUBLICATION DATE

23 Jan 74

PUBLICATION TITLE

Radar Set AN/PRC-76

BE EXACT PIN-POINT WHERE IT IS

PAGE NO	PARA-GRAPH	FIGURE NO	TABLE NO
---------	------------	-----------	----------

2-25	2-28		
------	------	--	--

3-10	3-3		3-1
------	-----	--	-----

5-6	5-8		
-----	-----	--	--

		F03	
--	--	-----	--

IN THIS SPACE TELL WHAT IS WRONG AND WHAT SHOULD BE DONE ABOUT IT:

Recommend that the installation antenna alignment procedure be changed throughout to specify a 2° IFF antenna lag rather than 1°.

REASON: Experience has shown that with only a 1° lag, the antenna servo system is too sensitive to wind gusting in excess of 25 knots, and has a tendency to rapidly accelerate and decelerate as it hunts, causing strain to the drive train. Hunting is minimized by adjusting the lag to 2° without degradation of operation.

Item 5, Function column. Change "2 db" to "3db."

REASON: The adjustment procedure for the TRANS POWER FAULT indicator calls for a 3 db (500 watts) adjustment to light the TRANS POWER FAULT indicator.

Add new step f.1 to read, "Replace cover plate removed in step e.1, above."

REASON: To replace the cover plate.

Zone C 3. On J1-2, change "+24 VDC to "+5 VDC."

REASON: This is the output line of the 5 VDC power supply. +24 VDC is the input voltage.

PRINTED NAME GRADE OR TITLE AND TELEPHONE NUMBER

SSG I. M. DeSpiritof 999-1776

SIGN HERE

DA FORM 2028-2  
1 JUL 79

PREVIOUS EDITIONS ARE OBSOLETE.

P S --IF YOUR OUTFIT WANTS TO KNOW ABOUT YOUR RECOMMENDATION MAKE A CARBON COPY OF THIS AND GIVE IT TO YOUR HEADQUARTERS

TEAR ALONG PERFORATED LINE

FILL IN YOUR  
UNIT'S ADDRESS

FOLD BACK

DEPARTMENT OF THE ARMY

OFFICIAL BUSINESS

**SAMPLE**

Commander  
US Army Communications-Electronics Command  
and Fort Monmouth  
ATTN: AMSEL-ME-MP  
Fort Monmouth, New Jersey 07703-5007

TEAR ALONG PERFORATED LINE



FILL IN YOUR  
UNIT'S ADDRESS

FOLD BACK

DEPARTMENT OF THE ARMY

OFFICIAL BUSINESS

Commander  
US Army Communications-Electronics Command  
and Fort Monmouth  
ATTN: AMSEL-ME-MP  
Fort Monmouth, New Jersey 07703-5007

TEAR ALONG PERFORATED LINE



FILL IN YOUR  
UNIT'S ADDRESS

FOLD BACK

DEPARTMENT OF THE ARMY

OFFICIAL BUSINESS

Commander  
US Army Communications-Electronics Command  
and Fort Monmouth  
ATTN: AMSEL-ME-MP  
Fort Monmouth, New Jersey 07703-5007

TEAR ALONG PERFORATED LINE



FILL IN YOUR  
UNIT'S ADDRESS

FOLD BACK

DEPARTMENT OF THE ARMY

OFFICIAL BUSINESS

Commander  
US Army Communications-Electronics Command  
and Fort Monmouth  
ATTN: AMSEL-ME-MP  
Fort Monmouth, New Jersey 07703-5007

TEAR ALONG PERFORATED LINE





FILL IN YOUR  
UNIT'S ADDRESS



FOLD BACK

DEPARTMENT OF THE ARMY

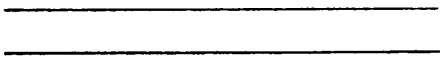

OFFICIAL BUSINESS

TEAR ALONG PERFORATED LINE

Commander  
US Army Communications-Electronics Command  
and Fort Monmouth  
ATTN: AMSEL-ME-MP  
Fort Monmouth, New Jersey 07703-5007

RECOMMENDED CHANGES TO EQUIPMENT TECHNICAL PUBLICATIONS



THEN...JOT DOWN THE DOPE ABOUT IT ON THIS FORM. CAREFULLY TEAR IT OUT, FOLD IT AND DROP IT IN THE MAIL.

SOMETHING WRONG WITH THIS PUBLICATION?

FROM: (PRINT YOUR UNIT'S COMPLETE ADDRESS)

DATE SENT

PUBLICATION NUMBER

TM 11-5820-923-12

PUBLICATION DATE

14 Feb 1986

PUBLICATION TITLE

Radio Set AN/GRC-213

BE EXACT PIN-POINT WHERE IT IS

PAGE NO.

PARA-GRAPH

FIGURE NO.

TABLE NO.

IN THIS SPACE TELL WHAT IS WRONG AND WHAT SHOULD BE DONE ABOUT IT:

11-5820-923-12 (1)

PRINTED NAME GRADE OR TITLE AND TELEPHONE NUMBER

SIGN HERE

DA FORM 2028-2 JUL 79

PREVIOUS EDITIONS ARE OBSOLETE

P.S. IF YOUR OUTFIT WANTS TO KNOW ABOUT YOUR RECOMMENDATION MAKE A CARBON COPE OF THIS AND GIVE IT TO YOUR HEADQUARTERS.

FILL IN YOUR  
UNIT'S ADDRESS

FOLD BACK

DEPARTMENT OF THE ARMY

OFFICIAL BUSINESS

Commander  
US Army Communications-Electronics Command  
and Fort Monmouth  
ATTN: AMSEL-ME-MP  
Fort Monmouth, New Jersey 07703-5007

TEAR ALONG PERFORATED LINE

By Order of the Secretary of the Army:

Official:

JOHN A. WICKHAM JR.  
*General, United States Army*  
*Chief of Staff*

MILDRED E. HEDBERG  
*Brigadier General, United States Army*  
*The Adjutant General*

Distribution:

To be distributed in accordance with special list.





