

NAVSHIPS 0967-187-5010
Formerly
NAVSHIPS 92134(A)

INSTRUCTION BOOK
for
R.F. SIGNAL
GENERATOR SET
AN/URM-25D,
AN/URM-25G
AND AN/URM-25H

DEPARTMENT OF THE NAVY
BUREAU OF SHIPS

★
Publication: 31 December 1953
Change 7: 7 December 1966
NAVSHIPS 0967-187-5016



INSTRUCTIONS

Change 4 to NAVSHIPS 92134(A)

Approved 11 December 1958

The purpose of this permanent change is to reflect changes made in the equipment manufactured under Contract NObsr 75083 as covered by INSTRUCTION BOOK FOR R. F. SIGNAL GENERATOR AN/URM-25D, NAVSHIPS 92134(A), dated 31 December 1953.

This permanent change is in effect upon receipt and supersedes Change 1, dated 17 March 1955, and Change 2, dated 31 August 1956.

1. Change book pages as follows:

Page	Remove	Insert
T. P. /A	Ch. 2/Ch. 2	Ch. 4/Ch. 4
B/C	Orig. /Ch. 2	Orig. /Ch. 4
1-0A/1-0B*	-----	Ch. 4/Ch. 4
1-3/1-4	Ch. 1/Orig.	Ch. 4/Orig.
4-1/4-2	Ch. 2/Orig.	Ch. 4/Ch. 4
4-7/4-8	Orig. /Ch. 1	Ch. 4/Ch. 1

*Insert supplementary page 1-0A immediately in front of page 1-1.

2. Make the following pen and ink corrections:

PAGE NO.	CHANGE IN EFFECT	PARA. & LINE OR FIG. & LOCATION	ACTION
1-0	Ch. 1	1-1	Add the following note to the figure: "FOR THE EQUIPMENT PROCURED ON CONTRACT NOBSR 75083 ONLY, P1001 IS DELETED AND FIXED ATTENUATOR CN-350/URM-25D (FIG. 1-1A) IS ADDED.
1-1	Ch. 1	1. <u>d</u> 15	Add after subparagraph (12): "(13) Fixed Attenuator CN-350/URM-25D (NObsr 75083 only)."

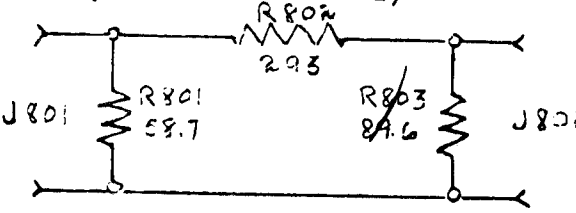
PAGE NO.	CHANGE IN EFFECT	PARA. & LINE OR FIG. & LOCATION	ACTION
1-5	Ch. 2	Table 1-5 <u>b</u> and <u>c</u>	Add to entries in second column: "NObsr 75083 Kings Electronics Co., Inc., Tuckahoe, N. Y."
2-6	Ch. 2	5. <u>a</u> 9	Change "0.05" to: "0.25"
4-6	Orig.	13. <u>a</u> (3) 2	Change "1K" to: "10K"
6-2	Orig.	8. <u>a</u> (1)	Change "Remove" to: "Disconnect" and change "(W101)" to: "(W101-1)"
6-3	Orig.	8. <u>b</u> (2) (<u>b</u>)	Change to read: "Insert the power cable (W101-1) into the AC source."
		11. <u>a</u> 1	Change "supply receptacle (J104)" to: "cable mounting plate"
		11. <u>c</u> 4	Change "receptacle (J104) in its proper position" to: "power cable mounting plate."
6-19	Orig.	9. <u>e</u>	Add after subparagraph e: "f. FIXED ATTENUATOR CN-350/URM-25D (NObsr 75083 only)."
6-25	Ch. 2	6-24	Add the following in the lower right-hand corner: "10:1 FIXED ATTENUATOR CN-350/URM-25D (NOBSR 75083 ONLY) 
6-27	Ch. 1	6-26 bottom	Add the following note to P1001: "(NOT PROCURED ON CONTRACT NOBSR 75083)"
7-0B	Ch. 2	CR101 4th col.	Add after "1N69": "1N69A (NObsr 75083 only)"
		M101 6th col.	Change "(24)" to: "(24 or 27)" Delete "Trad Dwg No. 107-A-9"
		M101 7th col.	Add after "107-B-670": "(Trad) or 107-A-9 (Kings)"

PAGE NO.	CHANGE IN EFFECT	PARA. & LINE OR FIG. & LOCATION	ACTION
7-OF	Ch. 2	P1101 1st col.	Add after "P1001": "(Except for NObsr 75083)"
7-3	Orig.	AT101 6th col.	Add after "(25) AT120": "or (27) Attenuator"
		AT101 7th col.	Add after "107-B-672": "(Trad) or 107-B-1000 (Kings)"
		AT101	Add the following after "AT101": 1st col.: "AT501" 2nd col.: "ATTENUATOR: impedance matching network; voltage ratio of 10:1 when matched." 3rd col.: "Permits operating 50-ohm output of generator into 70-ohm receiver." 6th col.: "(27) AT501" 7th col.: "107-B-740" 8th col.: "AT501" 9th col.: "1"
7-4	Orig.	C120 2nd col. 3	Change ". 520" to: ". 500 (NObsr 75083)" Change ". 250" to: ". 1875 (NObsr 75083)"
		C120 6th col.	Add after "(H1-K-12)": "or (27) 318 (H1-K-12)"
7-5	Orig.	C120 2nd col. 1	Change "3-48" to: "3-48NC-2 (NObsr 75083)"
7-5	Orig.	C120 2nd col. 2	Change ". -67" to: ". 032 (NObsr 75083)" Change ". 386" to: ". 375 (NObsr 75083)"
7-20	Orig.	R130 6th col.	Delete entry.
		R130 4th col.	Make the following entry: "RN20X5000F"
		Column 7	Delete all entries.
7-21	Orig.	Column 4	Make the following entries: For R152: "RN20X3933F" For R154: "RN20X1543F" For R157: "RV4LAYS253A"
		Columns 6 & 7	Delete all entries.

PAGE NO.	CHANGE IN EFFECT	PARA. & LINE OR FIG. & LOCATION	ACTION
7-22	Orig.	Column 4	Make the following entries: For R169: "RV4LAYS252A" For R301: "RN20X75ROF" For R302: "RN20X1200F" For R401: "RN20X61R1F" For R402: "RN20X2470F" For R501: "RN20X50ROF" For R701: "RN20X4000F"
7-24	Orig.	S103 col. 4	Change "ST22K" to: "ST52K"
		S103 col. 6	Change "(6)ST22K" to:"(28)ST52K"
7-29	Ch. 2	Table 7-6	Add the following to the table: "27 CANS Kings Electronics Co. , Inc. , Tuckahoe, New York. " "28 KKE Kulka Electric Mfg. Co. , Mount Vernon, New York"

3. Destroy superseded pages after the complete book has been checked against the "List of Effective Pages" and the "List of Pen and Ink Corrections. "

4. Remove and destroy Change 2, and then insert this "Instructions" sheet just behind the front cover.

INSTRUCTIONS

Change 2 to NAVSHIPS 92134(A)

Approved 31 August 1956

The purpose of this permanent change is to reflect changes made in the equipment manufactured under Contracts NObsr 71121 and NObsr 71304 and to incorporate changes included in TEMPORARY CORRECTION T-1 TO INSTRUCTION BOOK FOR RF SIGNAL GENERATOR AN/URM-25D, NAVSHIPS 92134(A), dated 1 February 1955.

This permanent change is in effect upon receipt and supersedes Temporary Correction T-1. It also supersedes Change 1, dated 18 March 1955, with respect to equipment starting with Serial Number 4700.

<u>Page</u>	<u>Remove</u>	<u>Insert</u>	<u>Page</u>	<u>Remove</u>	<u>Insert</u>
T.P./A	Orig./Orig.	Ch.2/Ch.2	6-27/6-28	Orig./Orig.	Ch.1/Ch.2
B/C	Orig./Orig.	Orig./Ch.2	6-29/6-30	Orig./Orig.	Ch.2/Orig.
1-5/1-6	Orig./Orig.	Ch.2/Orig	6-35/6-36	Orig./Orig.	Ch.2/Ch.2
2-1/2-2	Orig./Orig.	Ch.2/Ch.1	*7-0A thru 7-0F	- - - -	Ch.2
2-5/2-6	Orig./Orig.	Ch 2/Ch.2	7-27/7-28	Orig./Orig.	Orig./Ch.2
4-1/4-2	Orig./Orig.	Ch.2/Orig.	7-29/7-30	Orig./Orig.	Ch.2/Orig.
6-25,6-26	Orig.	Ch.2			

*Insert supplementary Pages 7-0A through 7-0F immediately in front of Page 7-1. Do not remove Pages 7-3 through 7-26.

2. Destroy superseded pages after the complete book has been checked against the "List of Effective Pages".
3. Remove and destroy the superseded Temporary Correction and then insert this "Instructions" sheet just behind the front cover.



NAVSHIPS 0967-187-5010
Formerly
NAVSHIPS 92134(A)

INSTRUCTION BOOK
for
R.F. SIGNAL
GENERATOR SET
AN/URM-25D,
AN/URM-25G
AND AN/URM-25H

DEPARTMENT OF THE NAVY
BUREAU OF SHIPS

★
Publication: 31 December 1953
Change 7: 7 December 1966
NAVSHIPS 0967-187-5016

LIST OF EFFECTIVE PAGES

PAGE NUMBERS	CHANGE IN EFFECT	PAGE NUMBERS	CHANGE IN EFFECT
Title Page	Change 7	5-0 & 5-1	Original
A	Change 7	6-0 & 6-1	Original
B	Original	6-2 to 6-4	Change 3
C	Change 7	6-5	Original
i & ii	Original	6-6	Change 3
iii	Change 3	6-7	Original
1-0	Change 1	6-8	Change 3
1-0A & 1-0B	Change 4	6-9 to 6-15	Original
1-1 & 1-2	Change 3	6-16	Change 1
1-3	Change 4	6-17 to 6-19	Original
1-4	Change 6	6-20 & 6-21	Change 3
1-5	Change 3	6-22 to 6-24	Original
1-6	Original	6-24A	Change 6
2-1	Change 3	6-25 & 6-26	Change 3
2-2	Change 1	6-25A & 6-26A	Change 6
2-3	Change 3	6-27	Change 1
2-4	Original	6-28	Change 3
2-5 to 2-7	Change 3	6-28A & 6-28B	Change 7
2-8 & 2-9	Original	6-29	Change 6
2-10	Change 3	6-30 to 6-34	Original
2-10A & 2-10B	Change 6	6-35 & 6-36	Change 3
2-11	Change 7	7-0AA to 7-0DD	Change 6
3-0 & 3-1	Change 1	7-0A to 7-0F	Change 2
4-0	Change 1	7-0G	Change 7
4-1 & 4-2	Change 4	7-1	Original
4-3 & 4-4	Change 3	7-2	Change 1
4-5	Original	7-3 to 7-29	Change 3
4-6	Change 3	i-1	Change 3
4-7	Change 5	i-2	Original
4-8 & 4-9	Change 1	i-3	Change 3
4-10 & 4-11	Original	i-4 & i-5	Original



DEPARTMENT OF THE NAVY
BUREAU OF SHIPS
WASHINGTON 25, D. C.

IN EARLY ORDER TO
Code 993-100
29 January 1954

From: Chief, Bureau of Ships
To: All Activities Concerned with the
Installation, Operation and Main-
tenance of the Subject Equipment
Subj: Instruction Book for RF Signal
Generator Set, AN/URM-25D,
NAVSHIPS 92134(A)

1. This is the instruction book for the subject equipment and is in effect upon receipt. This publication supersedes NAVSHIPS 92134.
2. When superseded by a later edition, this publication shall be destroyed.
3. Extracts from this publication may be made to facilitate the preparation of other Department of Defense Publications.
4. All Navy requests for NAVSHIPS Electronics publications should be directed to the nearest District Publications and Printing Office. When changes or revised books are distributed, notice will be included in the Bureau of Ships Journal and in the Index of Bureau of Ships General and Electronics Publications, NAVSHIPS 250-020.

W. D. LEGGETT, JR.
Chief of Bureau

TABLE OF CONTENTS

SECTION 1 – GENERAL DESCRIPTION		<i>Paragraph</i>	<i>Page</i>
<i>Paragraph</i>	<i>Page</i>		
1. Purposes and Basic Principles (of Operation)	1-1	16. General Instructions for Use	4-7
2. Detailed Description	1-1	a. Details	4-7
3. Equipment Similarities	1-3	b. Receiver Tests	4-7
4. Electron Tube Complement	1-3	c. Modulated Operation	4-10
		d. Receiver Output	4-10
		e. Receiver Overall Sensitivity	4-10
		f. Standard Antenna Electrical Constants	4-11
		g. Standard Levels	4-11
		h. Voltmeter used as an Output Meter	4-11
SECTION 2 – THEORY OF OPERATION			
1. General Description of Circuits	2-1	SECTION 5 – PREVENTIVE MAINTENANCE	
2. Signal Channel	2-2	1. Routine Maintenance Check Chart	5-0
3. Internal Modulation	2-4	2. Fuse Failure	5-0
4. External Modulation	2-5	3. Lubrication	5-0
5. Crystal Calibration	2-6	SECTION 6 – CORRECTIVE MAINTENANCE	
6. Variable RF Attenuator	2-7	1. Theory of Localization	6-1
7. Terminating the Signal Generator	2-9	2. Test Equipment for Making Repairs and Trouble Shooting	6-1
8. (5:1) Fixed Attenuator CN-223/URM-25D	2-9	3. System Trouble Shooting	6-1
9. Test Lead CX-1363/U	2-10	4. Tube Operating Voltages and Currents	6-1
10. Power Supply PP-977/URM-25D	2-10	5. Tube Socket Electrical Measurements	6-1
		6. Winding Data	6-1
		7. Exterior and Interior Views of Units	6-1
		8. Removing the Signal Generator and Power Supply from the Cabinet	6-1
		9. Removal and Replacement of Parts	6-3
		10. Removal of Oscillator Bracket Assembly	6-3
		11. Removal of Crystal Calibrator Bracket Assembly	6-3
		12. Removal of Audio Compartment Assembly	6-3
		13. Removal of Step Attenuator	6-3
		14. Replacing RF Oscillator Circuit Components	6-3
		15. Replacing Buffer and Amplifier Circuit Components	6-4
		16. Readjustment of Frequency Calibration	6-4
		17. Frequency Calibration Procedure	6-5
		18. Calibrating the Voltmeter	6-6
		19. Calibrating the Step Attenuator (AT101)	6-8
		SECTION 7 – PARTS LISTS	
SECTION 3 – INSTALLATION			
1. Unpacking	3-0		
2. Installation	3-1		
3. Adjustments	3-1		
SECTION 4 – OPERATION			
1. General	4-0		
2. Power Circuit	4-1		
3. Setting the Meter Zero	4-1		
4. Setting Carrier Frequency	4-1		
5. Crystal Calibrator	4-1		
6. Adjusting Output Voltage	4-2		
7. Internal Modulation and Audio Output	4-2		
8. External Modulation	4-2		
9. Terminating the Signal Generator	4-2		
10. Coupling to the Receiver under Test	4-5		
11. Use of Antenna Simulator SM-35/URM-25	4-5		
12. Use of Variable RF Attenuator	4-6		
13. Use of (5:1) Fixed Attenuator CN-223/URM-25D	4-6		
14. Use of (10:1) Fixed Attenuator CN-224/URM-25D	4-7		
15. Summary of Operation	4-7		

LIST OF ILLUSTRATIONS

SECTION 1 – GENERAL DESCRIPTION			SECTION 2 – THEORY OF OPERATION		
<i>Figure</i>	<i>Title</i>	<i>Page</i>	<i>Figure</i>	<i>Title</i>	<i>Page</i>
1-1	RF Signal Generator Set AN/URM-25D, Complete Equipment	1-0	2-1	RF Signal Generator SG-85/URM-25D, Functional Block Diagram	2-1

ORIGINAL

LIST OF ILLUSTRATIONS (Cont)

Figure	Title	Page	Figure	Title	Page
2-2	Simplified Schematic Diagram of the RF Oscillator	2-2	SECTION 6 - CORRECTIVE MAINTENANCE		
2-3	Simplified Schematic Diagram of the Buffer Stage	2-3	6-1	Failure Report	6-0
2-4	Simplified Schematic Diagram of the Output Amplifier Stage	2-3	6-2	Front Panel View for Removal of RF Signal Generator SG-85 URM-25D from Cabinet	6-2
2-5	Simplified Schematic Diagram of the Modulation Oscillator	2-5	6-3	Rear Bottom View for Removal of Power Supply PP-977 URM-25D from Cabinet	6-2
2-6	Simplified Schematic Diagram of the Modulation Cathode Follower and Crystal Rectifier	2-6	6-4	RF Signal Generator SG-85/URM-25D and Power Supply PP-977 URM-25D Connected Outside Cabinet for Testing	6-4
2-7	Simplified Schematic Diagram of the Vacuum Tube Voltmeter	2-7	6-5	Side View of Buffer - Amplifier Unit with Tubes in Position	6-5
2-8	Simplified Schematic Diagram of the Step Attenuator	2-8	6-6	Rear View of Buffer - Amplifier Unit with Tubes Removed	6-5
2-9	Simplified Schematic Diagram of the Crystal Calibrator	2-9	6-7	Bottom View of Buffer - Amplifier Unit	6-6
2-10	Schematic Diagram of the (5:1) Fixed Attenuator CN-223/URM-25D	2-10	6-8	Top and Bottom Views of Carrier Oscillator Bracket	6-7
2-11	Test Lead CX-13C3 U	2-11	6-9	Top and Bottom Views of Crystal Calibrator Bracket	6-9
2-12	Simplified Schematic Diagram of the Power Supply PP-977/URM-25D	2-11	6-10	Rear View of Oscillator Compartment	6-10
2-13	Schematic Diagram of Voltage Regulator	2-11	6-11	Rear View of Turret Selector Switch	6-10
2-14	Schematic Diagram of 115V-AG Power Source	2-11	6-12	Method for Calibrating the RF Signal Generator Set AN/URM-25D at Frequencies Below 100 Kilocycles	6-10
SECTION 3 - INSTALLATION			6-13	Bottom View of Signal Generator SG-85/URM-25D	6-11
3-1	RF Signal Generator Set AN/URM-25D, Packaging Diagram	3-0	6-14	Percentage Modulation Chart	6-20
3-2	RF Signal Generator Set AN/URM-25D, Outline Dimension Drawing	3-0	6-15	Signal Generator Voltage and Resistance Chart	6-21
SECTION 4 - OPERATION			6-16	Rear View of Audio and Metering Unit	6-22
4-1	RF Signal Generator SG-85/URM-25D	4-0	6-17	Interior View of Audio and Metering Unit Showing Terminal Board and Position of Resistors	6-22
4-2	Diagram Showing Vernier Reading of Frequency Scale	4-2	6-18	Top View of Signal Generator SG-85/URM-25D	6-22
4-3	Impedance Adapter MX-1487/URM-25D	4-3	6-19	Rear View of Signal Generator SG-85/URM-25D	6-23
4-4	Equivalent Circuit of RF OUTPUT X-MULT (J102) with Impedance Adapter MX-1487/URM-25D Added	4-3	6-20	Top and Bottom Interior Views of Step Attenuator AT101	6-23
4-5	Method of Inserting Impedance Adapter MX-1487/URM-25D at J102	4-3	6-21	Top and Bottom Views of the Power Supply PP-977/URM-25D	6-24
4-6	Equivalent Circuit of RF OUTPUT X-MULT (J102) with Series Matching Resistor Added	4-3	6-22	Interior View of (5:1) Fixed Attenuator CN-223/URM-25D	6-24
4-7	Equivalent Circuit of RF OUTPUT X-MULT (J102) with Shunt Resistor Added	4-4	6-23	Interior View of Antenna Simulator SM-35/URM-25	6-24
4-8	Schematic Diagram of the Antenna Simulator SM-35 URM-25 with Input Impedance Frequency Curve	4-5	6-24	RF Signal Generator Set AN/URM-25D, Overall Schematic Diagram	6-25, 6-26
4-9	Simplified Procedure for Operating the RF Signal Generator Set AN/URM-25D	4-8	6-25	Interior View of Impedance Adapter MX-1487/URM-25D	6-27
			6-26	RF Connectors and Cable Assemblies	6-27

LIST OF TABLES

SECTION 1 – GENERAL DESCRIPTION

<i>Table</i>	<i>Title</i>	<i>Page</i>
1-1	Equipment Supplied	1-3
1-2	Shipping Data	1-3
1-3	Basic Differences in AN/URM-25 Series Equipments	1-4
1-4	Electron Tube Complement	1-5
1-5	Reference Data	1-5

SECTION 4 – OPERATION

4-1	References for Correctly Terminating the Generator at J102	4-4
4-2	Methods for Correctly Terminating the Signal Generator at J102	4-4
4-3	Operational Summary of Front Panel Controls	4-9

SECTION 5 – PREVENTIVE MAINTENANCE

5-1	Routine Check Chart	5-0
5-2	Symptoms of Fuse Failure	5-1
5-3	Fuse Locations	5-1

SECTION 6 – CORRECTIVE MAINTENANCE

<i>Table</i>	<i>Title</i>	<i>Page</i>
6-1	Frequency Calibration Data	6-11
6-2	Trouble Symptom Chart	6-12
6-3	Chart of General Test Procedure for Localizing Trouble	6-13
6-4	Chart of Suggested Test for Locating the Specific Trouble	6-14
6-5	Tube Operating Voltages and Currents	6-28
6-6	Rated Tube Characteristics	6-29
6-7	Winding Data	6-30
6-8	Cross Reference Between Symbol Num- ber and Figure Location	6-35

SECTION 7 – PARTS LIST

7-1	Weights and Dimensions of Spare Parts Boxes	7-1
7-2	Shipping Weights and Dimensions of Spare Parts Boxes	7-1
7-3	List of Major Units	7-2
7-4	Combined Parts and Spare Parts List	7-3
7-5	List of Manufacturers	7-28
7-6	Applicable Color Codes and Miscellane- ous Data	7-29

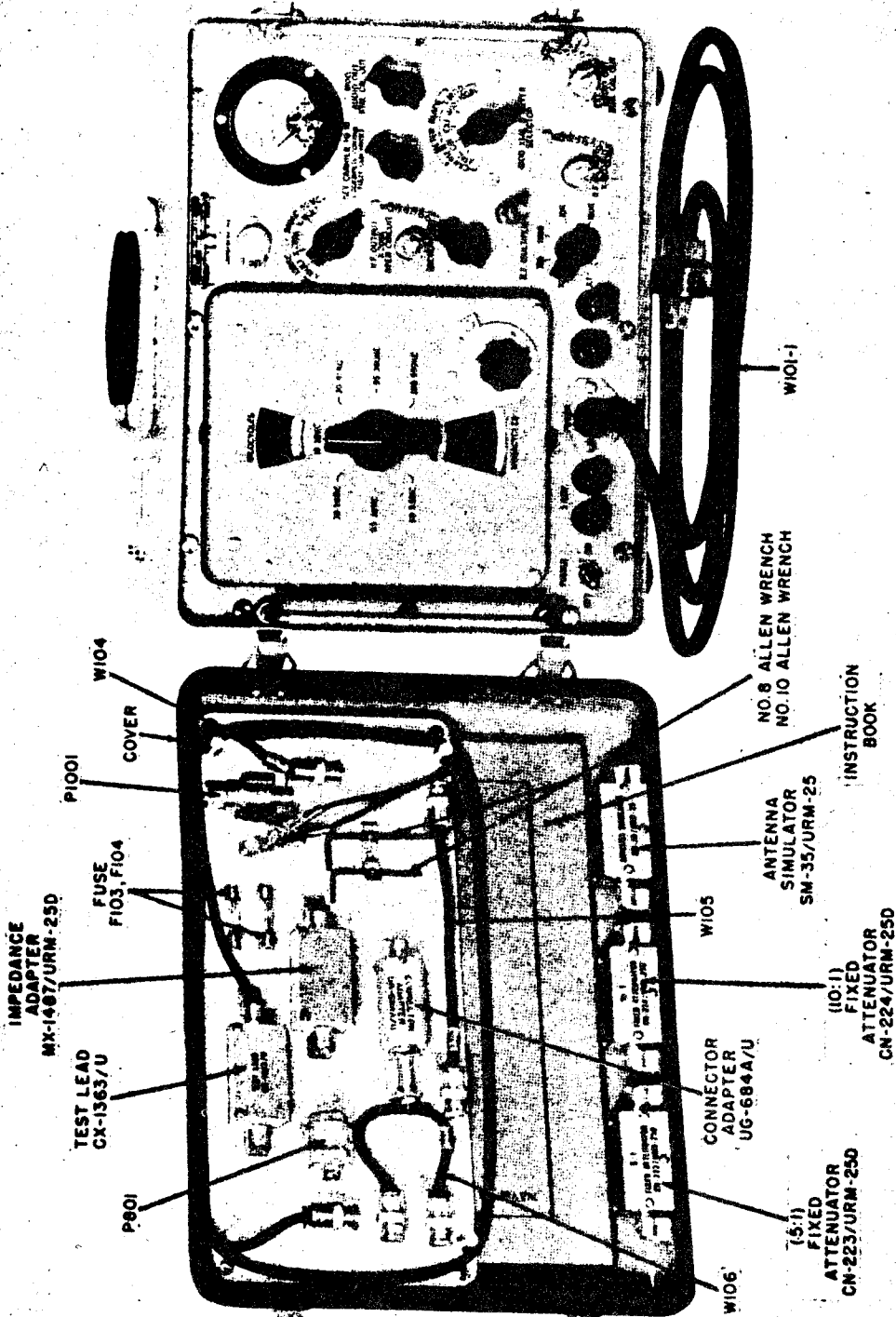

Figure 1-1. RF Signal Generator Set AN/URM-25D, Complete Equipment

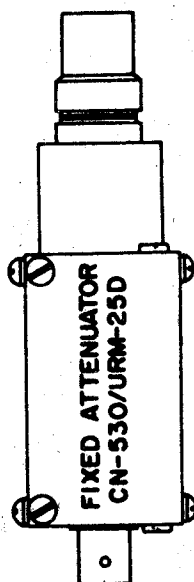

Figure 1-1. Fixed Attenuator CN-350/URM-25D (NOber 75083 Only)



SECTION 1

GENERAL DESCRIPTION

1. PURPOSE AND BASIC PRINCIPLES (OF OPERATION).

a. The RF Signal Generator Set AN/URM-25D is a test equipment intended primarily for bench testing of electronic equipment. Radio frequency signals, either modulated or unmodulated, can be generated by this Signal Generator Set over a continuous range of frequencies from 10 to 50,000 kilocycles.

b. All units, including the power supply, are incorporated in a single, portable cabinet (figure 1-1). The units supplied, with their corresponding weights, are shown in Table 1-1.

c. The AN/URM-25D operates from a source potential of 103 to 126 volts, 50 to 1000 cycles, single-phase ac. The equipment is so constructed and shielded that a known radio frequency voltage is obtainable at its output terminals in varying strength as indicated by a meter and associated multiplier. The unit includes a self-contained 1-mc crystal calibrator that is capable of establishing an accuracy within $\pm 0.25\%$ at frequencies above 10 mc.

d. The complete equipment consists of the following units:

- (1) RF Signal Generator SG-85/URM-25D
- (2) Power Supply PP-977/URM-25D
- (3) (5:1) Fixed Attenuator CN-223/URM-25D
- (4) (10:1) Fixed Attenuator CN-224/URM-25D
- (5) Impedance Adapter MX-1487/URM-25D
- (6) Test Lead CX-1363/U
- (7) Antenna Simulator SM-35/URM-25
- (8) Output RF Cable Assembly CG-409/U (3' 11")
- (9) Output RF Cable Assembly CG-409/U (0' 5")
- qty 2
- (10) Connector, Adapter
- (11) Coaxial Adapter UG-201A/U
- (12) Connector, Adapter UG-684A/U

2. DETAILED DESCRIPTION.

a. The 10 kc to 50,000 kc frequency range of the RF Signal Generator Set AN/URM-25D is covered in eight bands. Band selection is accomplished by rotating a turret containing RF oscillator coils. The control of the band selector is located on the front panel. Within each band the frequency is varied by means of a straight line frequency capacitor. The frequency generated can be read from a main frequency scale within an accuracy of $\pm 0.5\%$.

b. A 1-mc crystal calibrator incorporated in the signal generator will, when properly used, increase the RF carrier frequency accuracy from $\pm 0.5\%$ to $\pm 0.25\%$ at frequencies from 10-mc to 50-mc.

c. The RF output for the entire frequency range is continuously variable from 0.1 to 100,000 microvolts at

the RF OUTPUT X-MULT jack (J102) when properly terminated. Approximately 2 volts open circuit is available at the RF OUTPUT X-200K jack (J101). This voltage is measured by a meter located on the front panel. The voltage at the RF OUTPUT X-MULT jack (J102) is varied by the RF MULTIPLIER switch and the MICROVOLT control, whereas the voltage at the RF OUTPUT X-200K jack (J101) is varied only by the MICROVOLT control. The RF MULTIPLIER is a six-position step attenuator. The RF voltage at J102 is determined by multiplying the meter reading by the MULTIPLIER factor on the front panel.

d. An audio voltage of 400 or 1000 cycles, adjustable from 0 to approximately 3 volts by means of the $\%MOD$. AUDIOOUT - XTALCALOUT control, is available at the AUDIOOUT - XTALCALOUT - EXTMODIN jack (J105). This audio voltage is used mainly to modulate the RF carrier. Modulation is adjusted by the $\%MOD$ - AUDIOOUT - XTALCALOUT control from 0 to 50 percent. Percentage modulation is read directly on the lower scale of the same meter used to measure the RF voltage. Provision is also made for external modulation from 100 to 15,000 cycles per second when an external audio oscillator is used.

e. The RF oscillator (V101) with the crystal calibrator (V105) is completely enclosed in a shielded compartment located on the left side of the signal generator unit. The oscillator, of conventional Hartley type, makes use of a 6AH6 pentode tube connected as a triode. A rotary turret selector switch, containing eight coils and eight trimmer capacitors, and a main tuning capacitor are provided to generate oscillations over a frequency range from 10 kc to 50 mc. The rotary turret selector switch serves the following two functions:

(1) Selects the correct oscillator coil and trimmer capacitor.

(2) Selects proper grid leak resistance and blocking capacitance combination, and the proper cathode resistor.

f. The buffer stage (V102) is an untuned RF amplifier inserted electrically between the RF oscillator and the output amplifier stage. It is enclosed in a shielded compartment together with the output amplifier. It uses a 6AH6 pentode tube and serves the dual function of amplifying the RF signal and isolating the RF oscillator from changing load conditions. Its effect is to make the oscillator independent of the setting of either the MICROVOLTS control (R119) or the RF MULTIPLIER (AT101 Step Attenuator), and of any load that may be presented to the output of the signal generator. (See figure 6-25).

g. The output amplifier (V103), utilizing a type 6AG7 tube, amplifies the carrier output signal of the buffer stage. The signal is then applied to a VTVM (V104) circuit and the signal strength is indicated on a meter (M101).

b. Modulation is accomplished by introducing the audio voltage from the modulation oscillator (V106) or from an external source to the cathode follower (V107) and then to the grid of the output tube (V103). Due to the nature of the circuit, the amplitude of this audio voltage is directly correlated to the degree of modulation and adjustable by means of the %MOD - AUDIOOUT - XTAL CAL OUT control (R165). A portion of the audio voltage from the cathode follower (V107) is rectified and fed to the metering circuit for indication of %Modulation on M101.

i. The modulation oscillator is contained in the audio compartment and is a standard Wien-bridge oscillator, utilizing a type 5814 dual triode (V106). It is capable of generating an audio signal of either 400 or 1000 cycles, depending upon the position of the MOD-XTAL & METER SELECTOR switch (S102). When this switch is in the 400 or 1000-cycle position, the corresponding audio signal is applied to the cathode follower (V107) via %MOD - AUDIOOUT - XTALCALOUT (R165) and then to the grid of V103. In either position of S102 the audio voltage will also be available at EXT MOD IN jack (J105) for external applications. The audio voltage at J105 can be varied by %MOD - AUDIOOUT - XTAL CAL OUT control (R165). The impedance at J105 is high, and the audio voltage available will be proportional to the %Modulation reading on M101 when fed to a high impedance load. When a low impedance load is connected at J105, the audio output at J105 will decrease, but the meter reading will still be proportional to the audio output voltage. The maximum available open circuit audio voltage at J105 will be approximately 3 volts without overloading the meter (M101). The operational procedure for obtaining audio output is discussed in Section 4, OPERATION. The complete circuit will be found in figure 6-24. Besides functioning as an internal audio source, the modulation oscillator also serves as an amplifier for the audio beat of the crystal calibrator (V105).

j. The vacuum tube voltmeter (V104) in the buffer-amplifier compartment utilizes a double diode 5726 which is used to determine the output voltage of the RF signal. This voltage is measured by the meter (M101) when switch S102 is in the carrier position. The voltage indicated will be approximately equal to the peak value of the applied voltage. This voltage is read on the upper scale of M101, which is calibrated from 0 to 10 microvolts, to indicate the RMS effective value.

k. The RF attenuator controls consist of step attenuator AT101 and potentiometer MICROVOLTS control (R119). Both controls vary the carrier voltage applied to the X MULT RF OUTPUT jack (J102), but only the MICROVOLTS control (R119) affects the voltage at the X200,000 RF OUTPUT jack (J101). The value of the voltage at the X MULT RF OUTPUT jack (J102) is determined by multiplying the meter (M101) reading by the indicated position of the RF MULTIPLIER (E118). The entire circuit is effectively resistive so that the attenuation introduced is substantially independent of frequency within the limits of the instrument. The

output impedance of the attenuator system as taken from the X MULT RF jack (J102) is constant at 50 ohms for any position of the attenuator RF MULTIPLIER (E118). The attenuator (AT101) and associated circuit are shown schematically in figure 2-8.

l. The crystal calibrator (V105), incorporated in the RF oscillator compartment, provides crystal check points from 10 mc to 50 mc for purposes of interpolative calibration of the signal generator in this frequency range. The frequency accuracy of the crystal check points, at room temperature and at the moment of checking, is within 0.005%. The overall frequency accuracy of the equipment (10 mc to 50 mc), when checked against the crystal calibrator and including all variations of operating conditions, is within $\pm 0.25\%$. No provision is made for integral calibration below 10 mc where the accuracy is that of the direct reading frequency scale ($\pm 0.5\%$).

m. A CG-409/U (3' 11") coaxial output cable assembly (W104), consisting of a three-foot eleven-inch length of RG-58A/U cable and terminated at each end with a type UG-88/U connector, is supplied with the signal generator. This cable is intended for use with the X MULT RF OUTPUT jack (J102). It has a characteristic impedance of 50 ohms.

n. The (5:1) Fixed Attenuator CN-223/URM-25D consists of a two-section rectangular aluminum case approximately 2" long x 1" high x 1 1/4" wide. It contains two 75 ohm resistors and one 121 ohm resistor, in a pi-network providing a voltage attenuation of 5 to 1 when terminated in 50 ohms. A BNC type connector is provided at each end to fit W104 output cable CG-409/U (3' 11"), W105 and W106 output cables CG-409/U (0' 5"). These cables are used as required to make the necessary connections.

o. The (10:1) Fixed Attenuator CN-224/URM-25D is physically identical to the (5:1) Fixed Attenuator CN-223, URM-25D. It consists of two 61.9-ohm resistors (R401, R403) and one 249-ohm resistor (R402) connected in a pi-network to give an equivalent resistance of 50 ohms when properly terminated. This unit is the same in principle as the 5:1 attenuator but introduces a voltage attenuation of 10:1 instead of 5:1 when terminated in 50 ohms.

p. Antenna Simulator SM-35/URM-25 is contained in an aluminum case of the same type and physical dimensions as the impedance adapter and fixed attenuator units. One BNC type connector is provided at each end for connecting to any one of output cables W104, W105, or W106. The circuit consists of a 200 micromicrofarad capacitor (C701) in series with a series-parallel arrangement consisting of a 390-micromicrofarad capacitor (C702), a 402-ohm resistor (R701), and a 20-microhenry inductor (L701). At frequencies above 2.5 megacycles, the antenna simulator unit acts as a pure resistance of from 220 ohms to 400 ohms. Below 2.5 megacycles, the circuit acts as a capacitance of 200 micromicrofarads in series with an inductance of 200 microhenries and a resistance of 15 ohms. This simulator is identical to the RMA standard dummy load.

q. The Test Lead CX-1363/U should be used for making interstage receiver measurements. It consists of a 0.1 microfarad capacitor (C601) in parallel with a 510-micromicrofarad capacitor (C602) enclosed in an aluminum case similar to the antenna simulator and fixed attenuator units. One end of this case is terminated in a BNC connector. Two 16"-long clip leads extend from the other end. The capacitor network is in series with the red lead, whereas the black lead is grounded to the case.

qA. Fixed Attenuator CN-350/URM-25D (furnished only on Contract NObsr 75083) is contained in an aluminum case of the same type and dimensions as that used with the impedance adapter. The attenuator permits operating this 50-ohm signal generator into the 70-ohm impedance of a Navy receiver. The attenuator network consists of a pi attenuator designed to reflect proper impedance to both the signal generator and the receiver under test. The characteristics of the attenuator matching device require that a loss of 20 db in signal intensity be allowed for in measurement.

r. The Power Supply is an integral part of the RF Signal Generator Set AN/URM-25D. It is contained in a separate sub-chassis located to the rear of the RF signal generator unit SG-85/URM-25D. It employs a full wave rectifier type 6X4WA tube (V201). The interconnecting power cable (W102) is a two-conductor cable with a two-prong connector (P101) on one end. (See figure 6-4.) The other end of its cable is soldered to the a-c input fuses (F101, F102) located on the front panel of the signal generator. When the connector (P101) is plugged into the power supply input power receptacle (J201), this cable assembly (W102) transfers ac power from the front panel to the rectifier sub-chassis. This

interconnecting cable is connected in place and need not be installed prior to using the signal generator. A type 0A2 (V108) regulator tube located in the audio compartment is used for maintaining a regulated 150-volt dc output to V101 and V103. (See figure 2-13). The principal electrical features of the rectifier power unit are shown in figure 2-12.

s. The power transformer (T201) has a 450-volt center-tapped high-voltage secondary and a 6.5-volt filament secondary. It is designed to permit satisfactory operation from a 115V ($\pm 10\%$) single-phase ac source of from 50 to 1000 cycles per second. Each side of the input ac line is fused (F101, F102). An RF filter network, consisting of two 1000-micromicrofarad capacitors (C168, C169) and two RF chokes (L122, L123) enclosed in a metal shield, is mounted on the rear of the front panel of the RF Signal Generator SG-85/URM-25D (see figure 6-13). This network by-passes stray RF currents from the power line.

3. EQUIPMENT SIMILARITIES.

a. The AN/URM-25D, though similar in operation to previous models, incorporates basically different mechanical and electrical designs.

b. The frequency range 10 to 50,000 kc is divided differently (see table 1-5).

c. The output impedance of the Signal Generator Set AN/URM-25D is 50 ohms instead of 53.5 ohms used previously.

4. ELECTRON TUBE COMPLEMENT.

The quantities and types of electron tubes used with the AN/URM-25D are listed in table 1-4.

TABLE 1-1. EQUIPMENT SUPPLIED

QUANTITY PER EQUIPMENT	NAME OF UNIT	NAVY TYPE OR A-N DESIGNATION	OVERALL DIMENSIONS (INCHES)			VOLUME (CU. IN.)	WEIGHT (LBS.)
			HEIGHT	WIDTH	DEPTH		
1	RF Signal Generator Set	AN/URM-25D	11-1/4	14	10-3/4	1627	37
1	a. RF Signal Generator	SG-85/URM-25D					
1	b. Power Supply	PP-977/URM-25D					
1	c. (5:1) Fixed Attenuator	CN-223/URM-25D					
1	d. (10:1) Fixed Attenuator	CN-224/URM-25D					
1	e. Impedance Adapter	MX-1487/URM-25D					
1	f. Test Lead	CX-1363/U					
1	g. Antenna Simulator	SM-35/URM-25					
1	h. Output RF Cable Assembly	CG-409/U (3'11")					
2	i. Output RF Cable Assembly	CG-409/U (0'5")					
1	j. Connector, Adapter						
1	k. Coaxial Adapter (sym P801)	UG-201A/U					
1	l. Connector Adapter	UG-684A/U					
1	m. (10:1) Fixed Attenuator	CN-350/URM-25D					

TABLE 1-2. SHIPPING DATA

NUMBER OF BOXES	NAME	DESIGNATION	OVERALL DIMENSIONS (INCHES)			VOLUME (CU. IN.)	WEIGHT (LBS.)
			HEIGHT	WIDTH	DEPTH		
1	RF Signal Generator and Equipment Spares	AN/URM-25D	13	21	12.5	3412.5	44

TABLE 1-3. BASIC DIFFERENCES IN AN/URM-25 SERIES EQUIPMENTS

MODEL	LINE CORD	"EXT MOD IN" FILTER	FREQUENCY SCALE LAMP FILTER	CRYSTAL CALIBRATOR	RF PEAKING COIL	POWER SUPPLY	OTHER ITEM DIFFERENCES
AN/URM-25	Cord Filter. CX-1595/URM-25	Single section unshielded	none	none	One peaking coil for Band H (L-114)	L-201, T-201 Non types	
AN/URM-25A	Line cord Sym No. W-101	Triple section shielded	Triple section, shielded	none	One peaking coil for Band H (L-114)	RF bypasses C-205, C-206 added; L-201, T-201 JAN types	RF bypasses C-147, C-148 added to line filter
AN/URM-25B	Line cord Sym No. W-101	Triple section shielded in addition to an unshielded choke	Triple section, shielded	V-108 (6BE6) crystal calibrator	Two peaking coils (L-121, L-122), effective from 16 mc to 50 mc	RF bypasses C-205, C-206 added; L-201, T-201 JAN types	C-108 (.5 mf) removed, Adapter Connector UG-684/U added, C-149, C-156, E-131 and C-118 added, C-113 changed from 10,000 mmf to 6200 mmf, other wiring changes
AN/URM-25C	Line cord Sym No. W-101	Triple section shielded in addition to an unshielded choke	Triple section, shielded	V-108 (6BE6) crystal calibrator	Two peaking coils (L-121, L-122), effective from 16 mc to 50 mc	RF bypasses C-205, C-206 added; L-201, T-201 JAN types	6J4 (Buffer Amplifier) replaced by two 6AH6; 9004 (RF Diode) replaced by IN34 crystal; other circuit and component changes as required for above
AN/URM-25D	Line cord Sym No. W-101-1 LC filter	Single "L" section LC filter	none	V-105 (5750/6BE6W) crystal calibrator	Pass band accomplished with M-derived filter	Voltage Stabilizer changed to V-108 (OA2WA); R-201 is 3100 ohms, 22 watts	Entire tube complement (See table 1-4), and associated circuitry differs from preceding models
AN/URM-25G	Line Cord Sym No. W-101-1 LC filter	Single "L" section LC filter	none	V-105 (5750/6BE6W) crystal calibrator	Pass band accomplished with M-derived filter	Voltage Stabilizer is V-108 (OA2WA); R-201 is 3100 ohms, 22 watts. Filament voltage regulated. Added CR-201, CR-202 (1N2970B) and R-202, 7.5 ohms, 22 watts.	CR-101 and CR-102 changed to 1N277. R-104 changed to 3.3K. C-102, C-108, C-110, C-112, C-114 and C-116 changed to 4-30 uuf. C-120 changed to 1000 uuf. Other part changes made to satisfy MIL spec req.

TABLE 1-4. ELECTRON TUBE COMPLEMENT

REQUIRED NUMBER	TYPE TUBE	SYMBOL DESIG.	FUNCTION	LOCATION
1	6AH6	V101	Carrier Oscillator	Carrier Oscillator Compartment
1	6AH6	V102	Buffer Stage	Buffer-Amplifier Compartment
1	6AG7	V103	Output Amplifier	Buffer-Amplifier Compartment
1	5726/6AL5W 6097	V104	Carrier Voltmeter	Buffer-Amplifier Compartment
1	5750/6BE6W	V105	Crystal Calibrator	Carrier Oscillator Compartment
1	5814A	V106	Modulation Oscillator	Audio Compartment
1	6AH6	V107	Modulation Cathode Follower	Audio Compartment
1	0A2WA	V108	Voltage Stabilizer	Audio Compartment
1	6X4WA	V201	B + Rectifier	Power Supply PP-977/URM-25D

TABLE 1-5. REFERENCE DATA

a. Nomenclature	RF Signal Generator Set AN/URM-25D
b. Contract	NObsr 75306(FBM)
c. Contractor	Trad Electronics Corporation, Asbury Park, New Jersey
d. Cognizant Naval Inspector	Inspector of Naval Materials, Newark, New Jersey
e. Number of Packages Involved Per Complete Shipment	1
f. Total Cubical Contents	See Table 1-1
g. Total Weight	See Table 1-1
h. Frequency Range	10 to 50,000 kc \pm 0.5% 10 to 50 mc \pm 0.25% when calibrated against integral crystal.
i. Tuning Bands and Range of Each Band	
(1) Band A	10 to 30 kc
(2) Band B	30 to 95 kc
(3) Band C	95 to 300 kc
(4) Band D	300 to 950 kc
(5) Band E	.95 to 3.0 mc
(6) Band F	3 to 9.5 mc
(7) Band G	9.5 to 30 mc
(8) Band H	30 to 50 mc
j. Types of Amplitude Modulation	0 to 50% with indicated accuracy within 10%
(1) Internal Modulation Frequencies	a. 400 cycles per second \pm 5% b. 1000 cycles per second \pm 5%
(2) External Modulation Frequency	1000 to 15,000 cycles per second
k. Output Voltage (RF)	a. 0.1 to 100,000 microvolts \pm 10% when terminated by 50-ohm external load b. 2 volts adjustable across a high load impedance

TABLE 1-5. REFERENCE DATA (Continued)

l. Output Voltage (Audio)	
(1) Frequency	400 or 1000 cycles
(2) Voltage	0 to approximately 3 volts adjustable, across an output impedance of approximately 15,000 ohms.
(3) Adjustment	Voltage varied by front panel control
(4) Calibration	Proportional to reading of % Modulation
m. Output Impedance	
	a. 50 ohms at RF OUTPUT X-MULT jack (J102)
	b. 500 ohms at RF OUTPUT X-200K jack (J101)
	c. 15,000 ohms at EXT MOD IN-AUDIO OUT-XTAL CAL OUT jack (J105) for crystal calibration monitoring - 33,000 ohms for external modulation input
n. Power Supply PP-977/URM-25D	
(1) Power Source Requirements	115 volts \pm 10%, 50 to 1000 cycles per second, single-phase
(2) Power Consumption of Equipment	Approximately 48 watts

SECTION 2
THEORY OF OPERATION

1. GENERAL DESCRIPTION OF CIRCUITS

(See figure 2-1.)

a. The purpose of this section is to give the Electronic Technician a better understanding of the RF Signal Generator Set AN/URM-25D so that he can better apply himself to the operation and maintenance problems that may arise.

b. The functional principle of the AN/URM-25D is similar to that of a radio frequency transmitter. This association will become more apparent as the technician reads and studies this section. An RF oscillator (par. 2b) generates a variable RF signal which is applied via the buffer stage (par. 2c), to the control grid of the output amplifier stage (par. 2d). A modulation oscillator (par. 3b) generates an audio voltage (400 or 1,000 cycles) which is also applied to the control grid of the output stage to grid modulate the RF signal. The modulated signal is then taken from the output stage and fed to a step attenuator circuit (par. 9) where the desired output amplitude is selected. A vacuum tube voltmeter is provided for measuring the carrier output. Provision is also made for external modulation. The output of the modulation oscillator is available at the EXTMODIN-AUDIOOUT - XTALCALOUT jack (J105). A crystal calibrating circuit is also provided to calibrate the RF frequency from 10 mc to 50 mc. When this calibrator is

used, the frequency error can be made less than 0.25% at these frequencies.

c. A detailed analysis of the principal circuit assemblies is covered in this section under the following headings and paragraphs.

- | | |
|---------------------------------------|---------|
| (1) Signal Channel | Par. 2 |
| (2) Carrier Oscillator | Par. 2b |
| (3) Buffer Stage | Par. 2c |
| (4) Output Amplifier | Par. 2d |
| (5) Vacuum Tube Voltmeter | Par. 2e |
| (6) Signal Output Circuit | Par. 2f |
| (7) Internal Modulation | Par. 3 |
| (8) Modulation Oscillator | Par. 3b |
| (9) Cathode Follower Stage | Par. 3c |
| (10) Modulation Metering | Par. 3d |
| (11) External Modulation | Par. 4 |
| (12) Switching | Par. 4b |
| (13) Crystal Calibration | Par. 5a |
| (14) Crystal Calibrator | Par. 5b |
| (15) Beat Amplifier | Par. 5c |
| (16) Variable RF Attenuator | Par. 6 |
| (17) Terminating the Signal Generator | Par. 7 |
| (18) (5:1) Fixed Attenuator | Par. 8 |
| CN-223/URM-25D | Par. 9 |
| (19) Test Lead CX-1363/U | Par. 9 |
| (20) Power Supply PP-977/URM-25D | Par. 10 |

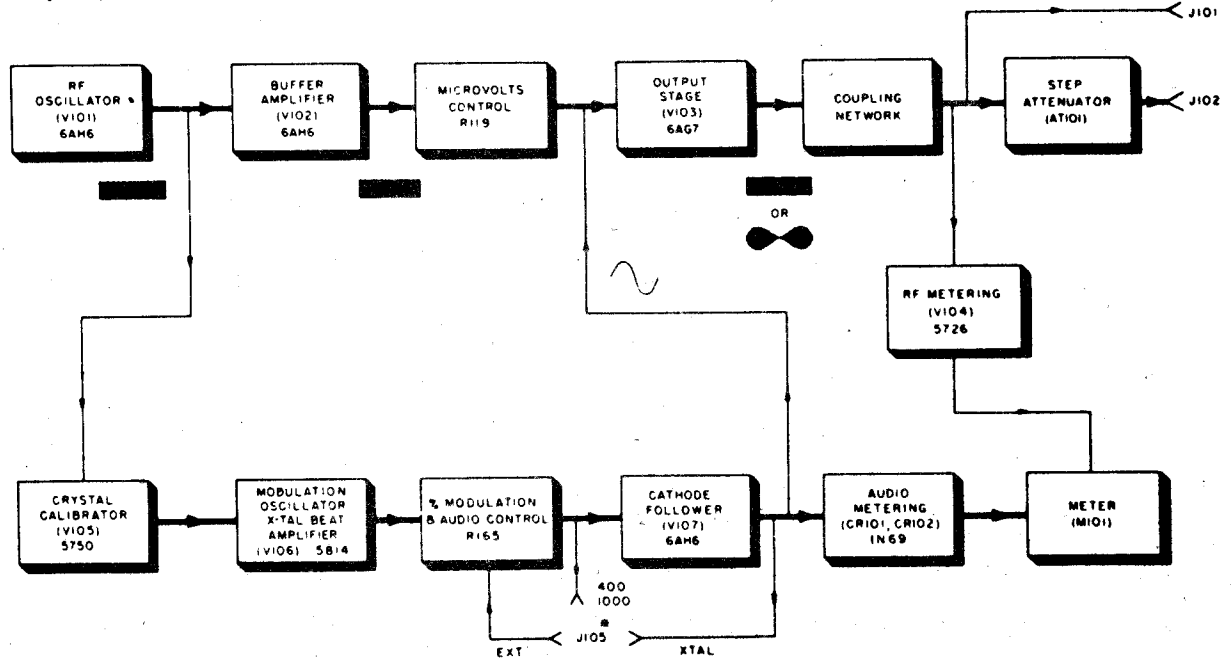

* J105 CONNECTION DEPENDS ON SWITCH S102 POSITION

Figure 2-1. RF Signal Generator SG-85/URM-25D, Functional Block Diagram

2. SIGNAL CHANNEL.

a. GENERAL.

The primary purpose of the signal channel is to generate a stable test carrier, calibrated in frequency and output amplitude and capable of sustaining audio amplitude modulation while remaining practically free from incidental frequency modulation.

b. CARRIER OSCILLATOR (See figure 2-2).

The carrier oscillator uses a triode connected pentode, type 6AH6, (V101). Variable capacitor (C123), 479 uuf, is the main tuning device and is used on all bands. Because of the relatively wide frequency range over which the oscillator must perform, the combination of coil, grid leak resistor, grid blocking capacitor, and isolating resistor selected for optimum conditions of frequency stability and coverage for each band, is switched by means of a specially designed rotary turret (Fig. 6-11). High frequencies generated in Band H present special problems. For instance, the band coverage has been shortened by use of a series padder capacitor (C118) in order to maintain a relatively high circuit impedance over the whole band. For the purposes of explanation, the turret will be considered to be positioned at band

"C". R105-1, C105-1 furnish automatic grid bias. Trimmer capacitor (C106) in conjunction with tuning slug adjustment of coil inductance are used in setting range of band covered by the main tuning capacitor (C123). R106 functions to stabilize the oscillator by isolating the tuning circuit from the tube, the parameters of which vary with changes in temperature, heater voltages, etc. The oscillator plate is maintained at rf ground potential at all frequencies generated with bypass capacitors (C120) and (C121) effective at high and low frequencies respectively. The plate voltage is supplied from a regulated +150V source, voltage regulator tube type OA2, (V108), and is varied by the SET CARRIER TO 10 control (R173) located on the front panel. The plate lead enters the oscillator compartment via the feed-through capacitor (C127) which is a part of a low-pass filter composed also of L109 and C125. This r-f filter is used to prevent rf from appearing outside of the oscillator compartment. A similar arrangement composed of C128, L110, and C126 is used to filter the filament supply. Output coupling capacitor (C119) has a very small capacity to isolate and minimize the effect of external shunt capacitance and its variations of the succeeding buffer stage and associated wiring.

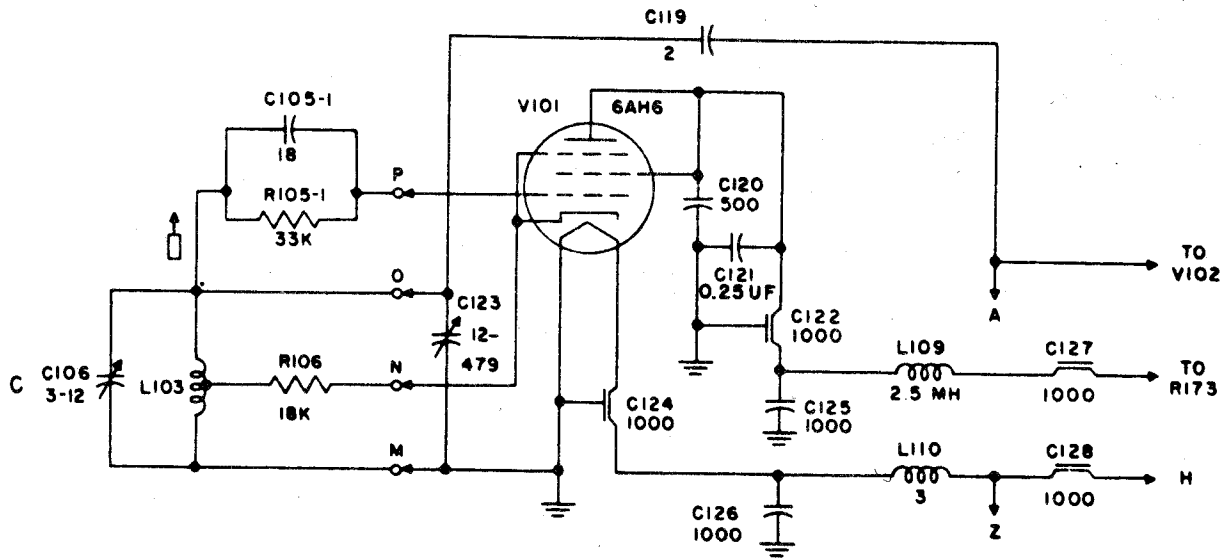

Figure 2-2. Simplified Schematic Diagram of the RF Oscillator

c. BUFFER STAGE (See figure 2-3).

The carrier signal is coupled by C119 and resistor R114 to the grid of a pentode, type 6AH6, (V102). The main purpose of the buffer stage is to isolate the oscillator stage from the effect of output loading and from modulating voltages. The operating point of the tube is established by the un-bypassed cathode bias resistor (R115). The screen is bypassed to ground with capacitor C129, .25 uf, and its voltage is supplied via resistor R117. The signal output of this stage is coupled to the OUTPUT amplifier (V103) by means of a frequency compensating network, (L111, R116) and (L112, R118), that is

basically an M-derived filter, and also by the series compensating circuit (L113 and R120) following the variable resistor (R119). This type of compensating is necessary because of the extreme frequency range (10kc to 50mc) of the pass band required. C130 is primarily a d-c blocking capacitor. The coupling capacitor (C131) is of a minimum value compatible with the coupling of carrier voltages, in order to prevent bypassing of higher audio frequencies when the grid of the succeeding stage (V103) is modulated. The variable resistor (R119) marked MICROVOLTS is the gain control and is located on the front panel. The series combination of R121 and

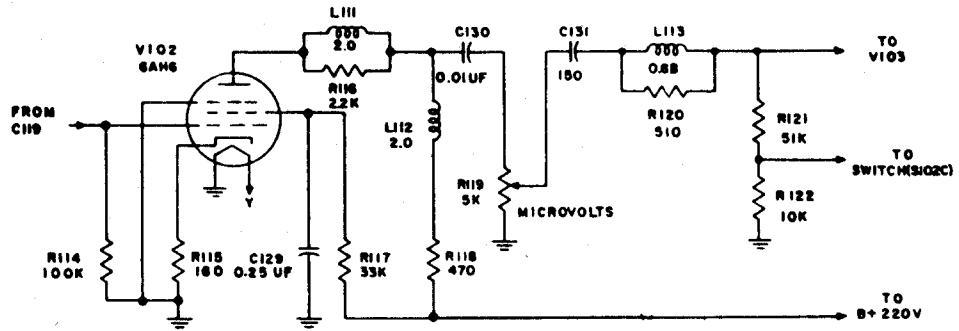

Figure 2-3. Simplified Schematic Diagram of the Buffer Stage

R122 provides grid return for the OUTPUT stage (V103), R122 being used to introduce modulating voltage into the grid circuit of that stage.

d. OUTPUT AMPLIFIER (See figure 2-4).

The output amplifier uses a power pentode type 6AG7, (V103). Bias for this stage, operating Class A, is obtained by the voltage drop across cathode resistor (R123). In order to bypass this resistor properly at all signal frequencies generated, capacitors C132, 25 uf, and C133, .022 uf, are used in parallel combination. The signal to be amplified, which may be modulated by an internally or externally generated audio frequency, appears at the grid (pin 4) of the tube (V103). The plate output circuit contains three major branches; first, the plate voltage is shunt-fed through the r-f chokes L116, L117, and L118 (Fig. 2-4). Next there is a series compensating network consisting of L114, L115, and its damping resistor (R124). C135 is simply a coupling capacitor. The 499 ohm resistor (R130) and the 55.56 ohm input impedance of step attenuator (AT101) in

series form the actual load for the output stage. Due to the fact that low frequencies generated by the signal channel are definitely in the audio region, the plate load impedance, when operating at these frequencies, must be kept high in order to develop sufficient output signal voltage. However, when the generated frequencies are above 300 kc (output/range switch [S101] in the 300 kc - 50 mc position), and when the generator is modulated by frequencies as high as 15 kc, it is desirable to prevent the audio voltage from appearing in the output. This is accomplished by shorting out the inductances (L117) and (L118), representing plate load impedance needed for low frequency operation. Additional isolation of the output from audio frequency variations is achieved by switching in the series capacitor (C136). This capacitor has very low reactance to high frequencies but high reactance in the audio frequency range. It is shorted when the output/range switch (S101) is in the 10 kc - 300 kc position. The switching described above is accomplished automatically, since the contacts are part of the output/range switch (S101).

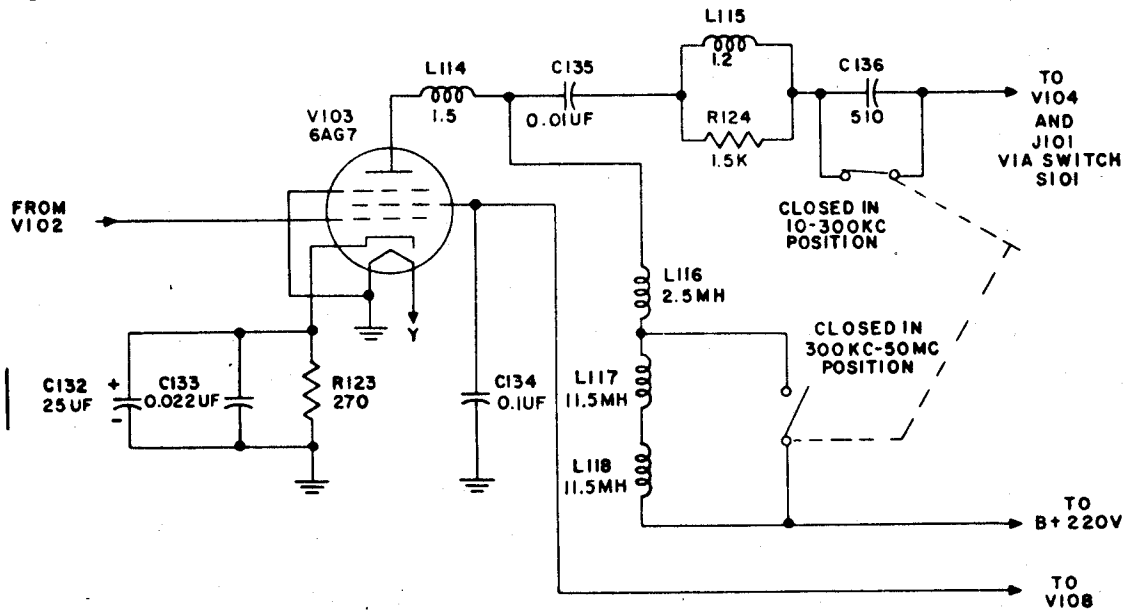

Figure 2-4. Simplified Schematic Diagram of the Output Amplifier Stage

e. VACUUM TUBE VOLTMETER (See figure 2-7).

The VTVM circuit uses a double diode type 5726 (V104), which, together with carrier meter (M101) and associated circuitry, enables the operator to maintain the correct input to the step attenuator (AT101) at all frequencies generated. The first diode (pins 1 and 7) is arranged to rectify the negative signal peaks. The second diode (pins 2 and 5) is connected inversely and serves to cancel the residual potential of the peak reading diode, as well as providing a convenient way to zero adjust carrier meter (M101). The rectified voltage appearing across capacitors C138 and C139 will approach the peak amplitude of the output signal voltage. This voltage also appears across the resistors R128, R144, and R172 in series, and the proportional d-c current resulting is read on carrier meter (M101). Optimum values of capacity are maintained over the frequency range by switching capacitor C139 in parallel with C138 when the output/range switch (S101) is in the 10 kc - 300 kc position. The no-signal current through the first diode is cancelled out by inserting the cathode of the second diode at the junction of R128 and R144. The plate of this diode is returned to ground through R126 and potentiometer R127 (CARRIER METER ZERO). The arm of R127 is connected to R125 and then to B plus. This forms a voltage divider allowing the positive voltage to bias the second diode and thus zero position the carrier meter (M101). This method offers better zero stability than a direct biasing of the rectifying diode.

f. SIGNAL OUTPUT CIRCUIT
(See figures 2-4 and 2-8).

There are two r-f output jacks located on the front panel. The jack (J101) marked X-200K OPEN CIRCUIT provides connections to a high level signal voltage source having internal impedance of 500 ohms (approx.) and output voltage up to 2 volts (open circuit). Jack (J102) marked X-MULT is the low level signal source with a constant 50 ohms internal impedance for all positions of R.F. OUTPUT X-MULT control (AT101). The output signal level available from this jack is adjustable from 100,000 microvolts to 0.1 microvolt when terminated by 50 ohms impedance. The metered signal voltage from the output amplifier (V103) appears across the 500 ohm precision resistor (R130) and the step attenuator (AT101). The output voltage source desired may be selected by positioning the output/range switch to the X-MULT or X-200K setting on either the 10kc - 300kc or the 300 kc - 50 mc position of this switch. When the output/range switch (S101) is in an X-200K position, the r-f output jack (J101) and series resistor (R129) are connected to the output circuit. The series resistor (R129) increases the internal resistance of the source but serves to isolate it from capacitive loading by the output jack (J101). When taking the signal from R-F OUTPUT X-MULT jack (J102) through the step attenuator (AT101) it is better to place the output/range switch (S101) in the X-MULT position of the required frequency range, thus removing resistor R129 from the output circuit and switching it to ground. This procedure maintains mini-

mum output distortion by removing any additional loading of the output circuit. The R.F. MULTIPLIER control is a step attenuator (AT101) providing 100 db. attenuation and is arranged to present a constant input (P103) and output (J102) impedance regardless of the position of the arm. Its output impedance is 50 ohms, available at the R.F. OUTPUT X-MULT jack (J102).

3. INTERNAL MODULATION.

a. GENERAL.

There are two internal modulation frequencies available. The desired frequency may be selected by turning MOD-XTAL & METER SELECTOR (S102) switch to 400 or 1000 cycles position. Meter M101 is scaled to read percentage of modulation in either of these positions.

b. MODULATION OSCILLATOR (See figure 2-5).

The basic circuit used during operation with internal modulation of the carrier signal is a resistance-capacitance tuned oscillator using a twin-triode, type 5814 (V106). The first half (pins 6, 7, and 8) of this tube is the input amplifier, and the second half (pins 1, 2, and 3) is the output amplifier. In this type of oscillator the frequency is determined by a network composed of resistors and capacitors which is placed in the positive feedback path. The combination of C160, R152 and C161, R153 is the 400 cycle frequency determining network. For 1000 cycle operation, R154 and R155 are switched into the circuit, replacing resistors R152 and R153. Negative feedback necessary to obtain good waveform in the oscillator output is supplied via resistors R156, R158, and R159, and the variable feedback control (R157). Capacitor C162 is a d-c blocking capacitor in the feedback path. The signal from the first amplifier appears across its plate load resistor (R160) and is capacity coupled (C164) to the grid of the second amplifier. This grid is returned to ground through resistor R163. The audio voltage output of the MODULATION OSCILLATOR is developed across the plate load resistor (R161) of the second amplifier and is coupled through capacitor C163 to the series network of isolating resistor (R164) and the gain control, marked % MODULATION. This control varies the degree of modulation of the r-f signal as indicated by the lower scale on meter M101. The audio voltage appearing at the arm of the gain control is connected through switch S102D to the AUDIO OUT jack (J105), where it is available for test purposes. The same audio voltage is coupled via capacitor C165 to the control grid of the CATHODE FOLLOWER tube (V107).

c. CATHODE FOLLOWER STAGE (See figure 2-6).

The audio voltage generated by the MODULATION OSCILLATOR appears at the grid of the CATHODE FOLLOWER which utilizes a triode connected pentode, type 6AH6 (V107). The purpose of this stage is to isolate the MODULATION OSCILLATOR from varying load and to act as a low impedance source of the modulation voltage coupled to the grid circuit of the OUTPUT AMPLIFIER (V103) in the SIGNAL CHANNEL. The grid of the cathode follower stage is returned through resistor R166 to the junction of cathode load

resistors (R167 and R168). The plate is connected directly to the plus supply. Capacitor C166 couples the audio modulating voltage appearing across cathode resistors R167 and R168, via an r-f filter C147, R142, C142, to the grid circuit of the OUTPUT AMPLIFIER (V103), where the audio modulation voltage is developed across R122. The same audio voltage is coupled by capacitor C167 to the MODULATION METERING circuit, where it is measured.

d. MODULATION METERING (See figure 2-6).

The proportion of the known r-f voltage and modulating audio actually appearing at the grid (pin 4) of the OUTPUT AMPLIFIER (V103) determines the degree of modulation. The function of the modulation metering circuit is to indicate the degree of modulation as a percentage through measuring the amplitude of the audio voltage. The circuit consists of a bridge-type rectifier producing a current through M101 proportional to the audio voltage output of the CATHODE FOLLOWER STAGE. The voltage is capacity coupled to two crystal diodes, type 1N69 (CR101, CR102), which are used in conjunction with bridge resistors (R170 and R171) to rectify the modulation voltage. % MODULATION METER (M101) is calibrated by a series variable resistor (R169).

4. EXTERNAL MODULATION.

a. GENERAL.

In the event that carrier modulating frequencies other than 400 or 1000 cycles are required, provision is made to connect the signal generator to an external source of audio voltage. This is accomplished by a switching

arrangement whereby the function of jack J105 is changed to accept the external modulation signal and the EXT MOD IN marking on the front panel applies.

b. SWITCHING (See figure 2-6).

There are no additional tubes involved when the signal generator is functioning with EXTERNAL MODULATION. The major circuit changes are made by the sections of the MOD-XTAL & METER SELECTOR switch (S102), when it is turned to the EXT position as follows:

(1) Section S102D EXT connects the EXT MOD IN jack (J105) and the external audio signal through the r-f decoupling filter (L124, C170) across the parallel combination of fixed resistor R164 and gain control (% MOD) R165. The signal is then coupled from the arm of R165 through coupling capacitor (C165) to the grid of the CATHODE FOLLOWER stage (V107), which then functions as explained in paragraph 3c of this section.

(2) Section S102B EXT grounds the output of the second amplifier of the MODULATION OSCILLATOR (V106) at the junction of coupling capacitor (C163) and isolating resistor (R164). This also places R164 in parallel with variable resistor (% MOD.) R165, making the input resistance for external modulating voltages at J105 equal to 33K ohms (approx.).

(3) Section S102A EXT completely disables the MODULATION OSCILLATOR (V106) by directly grounding the grid of the first amplifier.

(4) Section S102C EXT completes the switching of the EXTERNAL MODULATION function by connect-

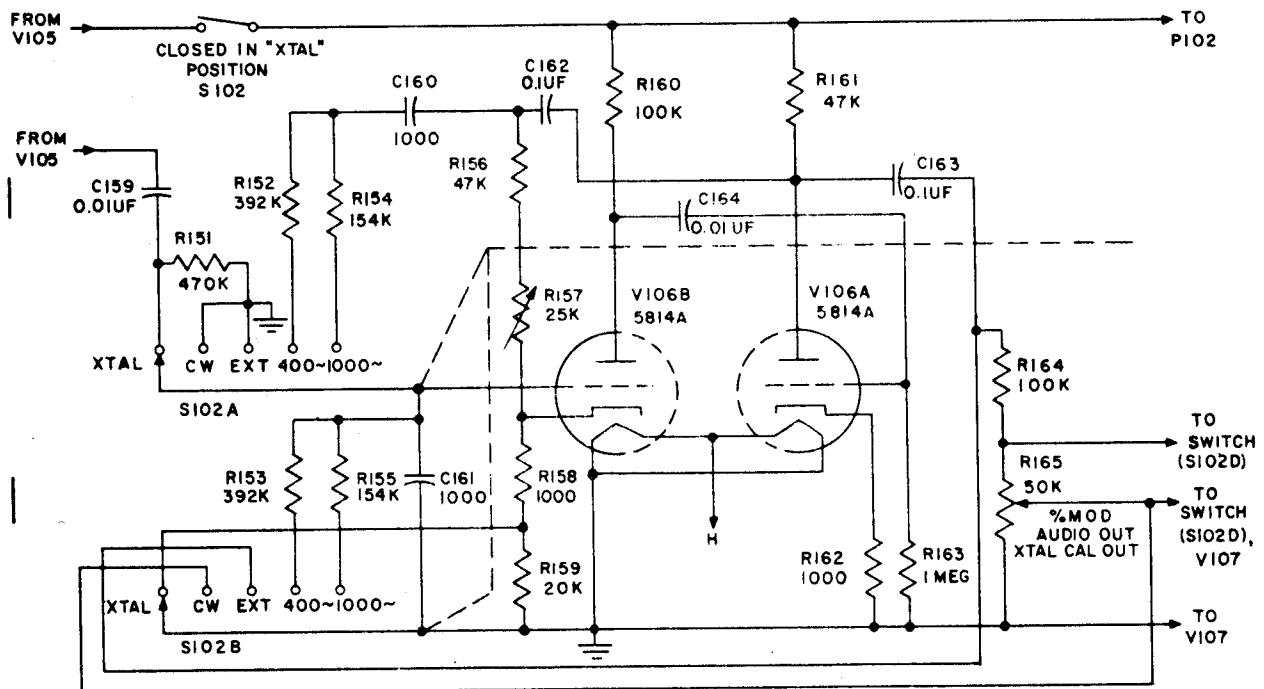

Figure 2-5. Simplified Schematic Diagram of the Modulation Oscillator

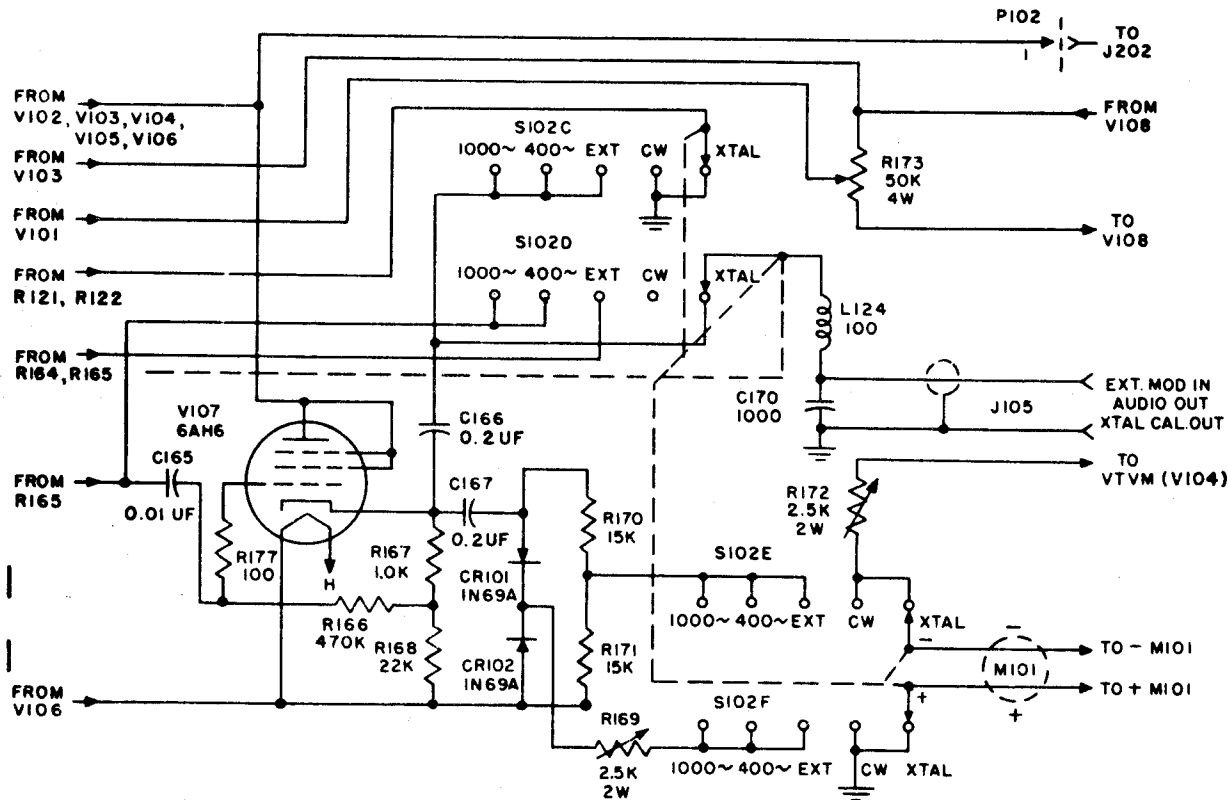

Figure 2-6. Simplified Schematic Diagram of the Modulation Cathode Follower and Crystal Rectifier

ing the audio modulation output of the CATHODE FOLLOWER stage (V107) to the grid circuit (R121, R122) of the modulated OUTPUT AMPLIFIER (V103) in the SIGNAL CHANNEL.

(5) The OUTPUT METERING (M101) circuit performs the same function during the external modulation that it does when internal modulation is being used. See paragraph 3d of this section.

5. CRYSTAL CALIBRATION.

a. GENERAL.

The purpose of the CRYSTAL CALIBRATION function of the signal generator is to provide a means by which the operator can by the use of a vernier dial control, interpolate the frequency of signals between dial divisions (Section 4, par. 4). It is of greatest use in the higher frequency range. The frequency of the crystal oscillator has been adjusted by comparison with a frequency standard. The accuracy of the signal oscillator frequency, when determined in this manner, is 0.25 percent.

b. CRYSTAL CALIBRATOR (See figure 2-9).

The CRYSTAL CALIBRATOR is located in the oscillator compartment of the signal generator. It uses a type 5750 (V105) performing the dual functions of a triode

crystal oscillator and a mixer stage. The stage is supplied operating d-c voltage only when the MOD-XTAL & METER SELECTOR (S102) is in the XTAL position. In the crystal oscillator portion of V105 the No. 2 grid (pin 6) acts as the plate of a triode, with the No. 1 grid (pin 1) and the cathode (pin 2) forming the remainder of the triode. The crystal oscillator circuit is a grounded plate type. The positive operating voltage is supplied to the No. 2 grid via R145, which is kept at r-f ground potential by capacitor C155. The common cathode reactance, resulting from the combination of capacitor C156 and coil L121, provides the grid-plate circuit feedback necessary to sustain oscillation. The frequency of oscillation is controlled by the quartz crystal Y101, with slight correction enabled, when necessary, by the variable capacitor (C158). The control grid is returned to ground by resistor R147. A small fraction of the r-f signal from the CARRIER OSCILLATOR is taken from the output coupling capacitor (C119) by a high resistance voltage divider (R176 and R148) and injected into the mixer grid (pin 7) of the tube V105. The plate (pin 5) current is modulated by both the frequency from the 1-mc crystal oscillator, and the frequency injected from the CARRIER OSCILLATOR (V101). This mixing of the two signals and their harmonics results in sum and difference beat notes. The audio frequency difference is selected in the plate circuit through bypassing the

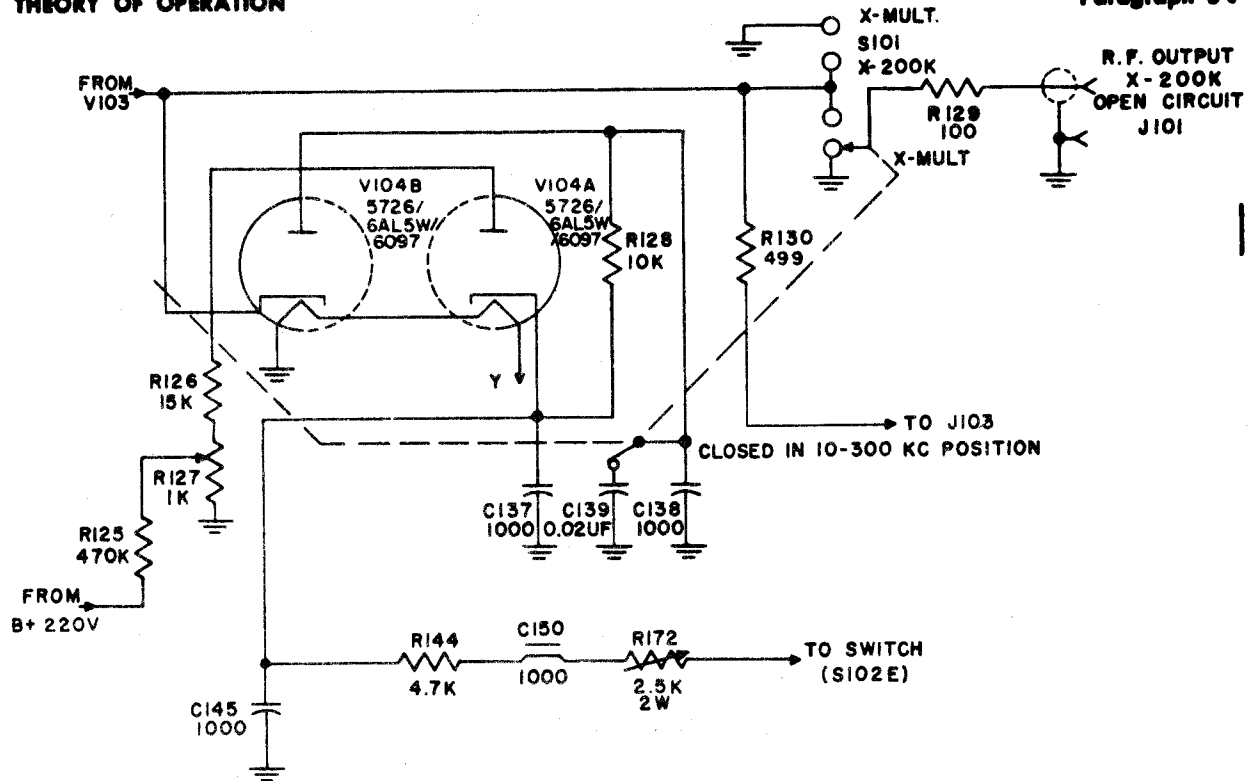

Figure 2-7. Simplified Schematic Diagram of the Vacuum Tube Voltmeter

radio frequency components to ground. Capacitor C152 performs this function. Resistor R146 is the plate load impedance. The audio beat note is coupled via the low-pass filter (R150, C154) through coupling capacitor (C159) to the grid circuit of the BEAT AMPLIFIER (V106).

c. BEAT AMPLIFIER.

When the MOD-XTAL & METER SELECTOR (S102) is placed in XTAL position, the function of the twin-triode tube (V106) is switched from its alternate function as a MODULATION OSCILLATOR to that of a two-stage beat amplifier. The audio beat output voltage from the CRYSTAL CALIBRATOR (V105) stage is applied through XTAL contact of switch (S102A) to the grid (pin 7) of the first amplifier section (pins 6, 7, and 8) of the stage. The grid is returned to ground by R151. Cathode bias is developed across resistor R158. Resistor R159, formerly used in the negative feedback path of the oscillator circuit, is shorted by the XTAL contact of S102B. The output of the first amplifier is coupled by C164 to the grid (pin 2) of the second amplifier. The grid is returned to ground through R163. Bias is furnished by the voltage drop across the cathode resistor (R162). The output signal of the BEAT AMPLIFIER stage is developed across the plate load resistor (R161) and after the coupling capacitor (C163), it appears across the series combination of resistor R164 and the gain control (R165) in its XTAL CAL OUT

function. The arm of the gain control (R165) is connected to a coupling capacitor (C165) which introduces the signal at the grid of the CATHODE FOLLOWER stage.

d. CATHODE FOLLOWER.

The cathode follower stage (V107) performs basically as described in paragraph 3c of this section. However, the signal output is routed differently. The audio beat signal is coupled from the cathode via capacitor C166 through the XTAL contact of switch (S102D) to jack (J105) acting in its XTAL CAL. OUT function. This connection facilitates monitoring of the audio beat frequencies with headphones or other indicating device.

6. VARIABLE RF ATTENUATOR

(See figure 2-8).

a. The RF attenuator circuit consists of step attenuator AT101 and potentiometer MICROVOLTS control (R119). Both controls vary the carrier voltage applied to the X MULT RF OUTPUT jack (J102) but only the MICROVOLTS control (R119) affects the voltage at the X-200,000 RF OUTPUT jack (J101). The value of the voltage at the X MULT RF OUTPUT jack (J102) is determined by multiplying the meter (M101) reading by the indicated position of the RF MULTIPLIER (E118). The entire circuit is effectively resistive so that the attenuation introduced is substantially independent of frequency within the limits of the instrument. The

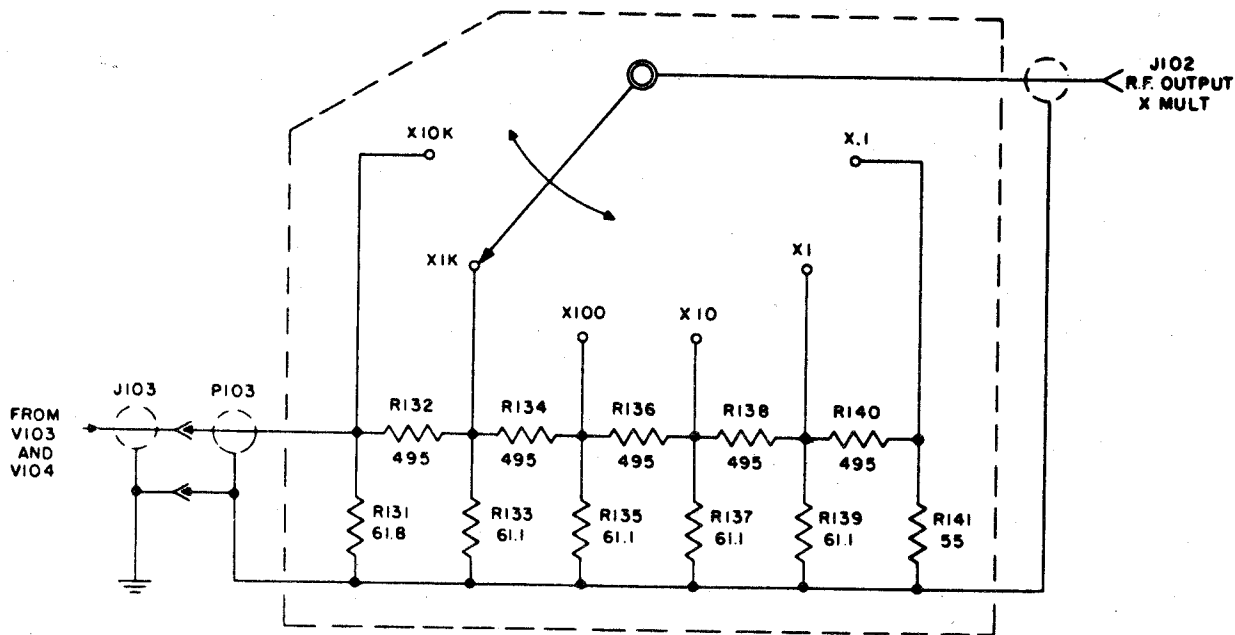

Figure 2-8. Simplified Schematic Diagram of the Step Attenuator

output impedance of the attenuator system as taken from the X MULT RF OUTPUT jack (J102) is constant at 50 ohms for any position of the attenuator RF MULTIPLIER (E118). The attenuator (AT101) and associated circuit are shown schematically in figure 2-8.

b. The X-200,000 RF OUTPUT jack (J101) voltage is taken from the output amplifier stage (V103) and is not attenuated by the step attenuator (AT101). The voltage developed across this jack depends upon the setting of the carrier control (R173) and MICROVOLTS control (R119) and its output impedance is constant at 500 ohms.

c. Whenever the frequency of the signal generator is changed, reset the X-200,000 RF OUTPUT jack (J101) voltage for a meter reading of "10", by rotating the MICROVOLTS control (R119) fully clockwise and then rotating the carrier control (R173) in a clockwise direction until the meter reads "10", this represents two volts open circuit output from J101.

d. The step attenuator (AT101) attenuates the output from the X MULT RF OUTPUT jack (J102) in steps of ten as indicated on the front panel by RF MULTIPLIER knob (E118). The voltage at J101 will not be affected by the position of this knob.

e. The useful output voltage from the X MULT RF OUTPUT jack (J102) is always based on terminating this jack in its characteristic impedance (50 ohms); thus, when the output from J102 is fed to a receiver under test, with the impedance properly matched, the reading on the signal generator meter will indicate the input voltage to the receiver under test. This is discussed more fully

in section 2 paragraph 7, TERMINATING THE SIGNAL GENERATOR.

f. When the voltage from V103 is set at "10" on the meter, the maximum output from the X MULT RF OUTPUT jack (J102), when correctly terminated (50 ohms) will be 0.1 volts while open circuit voltage at J101 will be 2 volts. Adjustments in steps of 10 are obtained for each step of the attenuator (AT101), at the output from the X MULT RF OUTPUT jack (J102) by rotating R119. The output voltage from this jack is determined in microvolts by multiplying the meter (M101) reading by the corresponding position of the RF MULTIPLIER knob (E118). Since the accuracy of all meters is expressed in terms of percentage error for full scale deflection, the technician should avoid using the meter calibrations below "2". Use the (5:1) Fixed Attenuator CN-223/URM-25D whenever a meter voltage indication in this range is required. This attenuator is discussed more fully in paragraph 8 of this section.

g. For any particular carrier frequency, once the carrier control (R173) has been rotated to give the required "10" meter indication, its setting should never be changed. The output from each attenuated step and from the X-200,000 RF OUTPUT jack (J101) is varied by adjusting the MICROVOLTS control (R119). Whenever the generator frequency is changed, however, the carrier control must be reset to give the required "10" meter indication. This adjustment is made only after R119 has again been rotated to the fully clockwise position.

h. When R173 and R119 have been adjusted to introduce a two volt signal (M101 reads "10" and J101

unterminated) to the step attenuator (AT101), the series voltage dropping resistor (R130) reduces this voltage to 0.2 volts. The maximum output voltage available from the X MULT RF OUTPUT jack (J102) when this jack is terminated in 50 ohms, will, therefore, be 0.1 volts. This will also be the maximum input voltage from this jack to a properly matched receiver under test. (See Section 2, par. 7). It is this voltage, under terminated conditions, that is actually indicated on M101. The MICROVOLTS control (R119) provides smooth control of the voltage applied to the step attenuator.

i. The step attenuator (AT101) is a six section ladder resistance network and its output is attenuated in six steps. With the MICROVOLTS control (R119) and the attenuator (AT101) in combination, any desired voltage between zero and 100,000 microvolts can be obtained at the X MULT RF OUTPUT jack (J102) when the jack is terminated in its characteristic impedance (50 ohms). The input voltage to the receiver under test is thus determined by multiplying the meter (M101) reading (upper scale) by the decimal multiplier indicated by the position of the RF MULTIPLIER knob (E118). The lowest calibrated output voltage is 0.1 microvolts.

7. TERMINATING THE SIGNAL GENERATOR.

a. The termination principles herein discussed are based on the assumption that the load is essentially resistive in nature. This is true for most applications for which this equipment is used in the field. In cases where

the load is not resistive, it will be necessary for the technician to interpret these principles with respect to the nature of the load.

b. Cable W104 has a capacitance of 29 mmf. ft or a total capacitance of 113.5 micromicrofarads for the entire length. The resultant reactance would have no appreciable effect on the output of J102 at frequencies below 1 mc and, therefore, standing waves do not introduce a termination problem at these frequencies.

c. At frequencies greater than one megacycle, the decrease in cable reactance begins to introduce a pronounced shunting effect on the 50 ohm generator terminal (J102) impedance and it becomes necessary to correctly terminate the receiving end of W104 in order to eliminate standing waves. There is no need to terminate the signal generator end of the cable since its characteristic impedance of 50 ohms is the same as the characteristic impedance across J102.

8. (5:1) FIXED ATTENUATOR CN-223/URM-25D
(See figure 2-10)

a. The schematic diagram of the 5:1 fixed attenuator is shown in figure 2-10. This attenuator is designed to be used when the input impedance of the receiver under test, is 50 ohms, and consists of three resistors (R301, R302, R303) connected in a pi-network to give an equivalent resistance of 50 ohms when properly terminated in 50 ohms. It can readily be calculated that the output terminal voltage of this attenuator unit will be

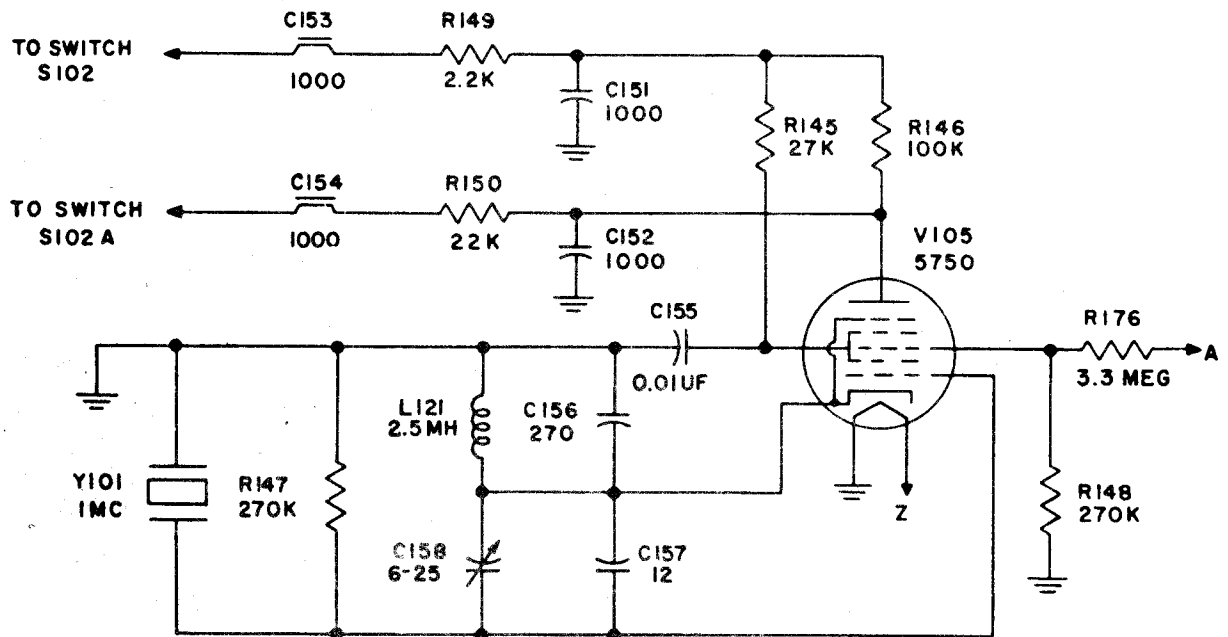

Figure 2-9. Simplified Schematic Diagram of the Crystal Calibrator

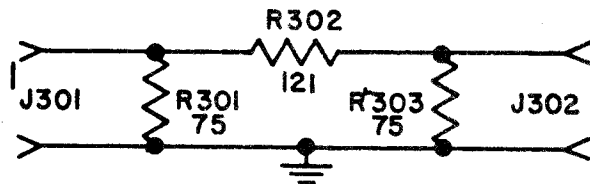

Figure 2-10. Schematic Diagram of the (5:1) Fixed Attenuator CN-223/URM-25D

one-fifth its input voltage when the CN-223/URM-25D is properly terminated in 50 ohms. It therefore follows that the voltage output from the fixed attenuator will be one fifth the voltage indicated by M101.

b. The 5:1 fixed attenuator is designed for a 50 ohm terminating impedance and should be used in conjunction with the X-N. LT RF OUTPUT jack (J102), never with the X-200,000 RF OUTPUT jack (J101).

c. A (10:1) fixed attenuator CN-224/URM-25D, similar in construction to the 5:1 fixed attenuator, is provided to check the step attenuator positions.

9. TEST LEAD CX-1363/U

(See figure 2-11).

a. The capacitor network is inserted to protect the step attenuator (AT101) of the signal generator from accidental test probing at points of B+ potential and should always be used when making interstage receiver tests.

b. The reactance of the test lead capacitors should not normally affect the accuracy of the meter (M101) voltage indication since, in most cases, the impedance at receiver interstage measurement points will be high. It must be

realized, however, that when the CX-1363/U is used at test points of low impedance (below 400 ohms) the meter indication can no longer be depended upon to reflect the actual signal voltage applied.

10. POWER SUPPLY PP-977/URM-25D

(See figure 2-12).

a. The plate supply voltage derived from the high voltage secondary and rectifier tubes (points "PQ" on figure 2-12) is approximately 220 volts DC and must be reduced to the required 150 volts DC regulated supply for tubes V101 and V103. This voltage drop is achieved by the DC series dropping resistor (R201). A pi filter network consisting of a choke (L201) and three 4 microfarad capacitors (C201, C202, C203) is provided as a ripple filter. The two capacitors (C202, C203) are connected in parallel to increase the effective capacitance. A single 8 microfarad capacitor would introduce a problem of physical location. An additional 0.15 microfarad capacitor (C204) is inserted in parallel with L201 to form a 120 cycle resonant filter. This resonant filter lowers the 120 cycle power supply hum level.

b. In a regulator tube such as the OA2 (V108), the voltage across the tube (150vDC) remains constant over a fairly wide range of current (5 to 30ma) through the tube. This property exists because the degree of ionization of the gas in the tube varies with the amount of current that the tube conducts. When a large current is passed, the gas is highly ionized and the internal impedance of the tube is low. When a small current is passed, the gas is ionized to a lesser degree and the internal impedance is high. Over the operating range of the tube, the product (IxR) of the current through the tube and the internal impedance of the tube is prac-

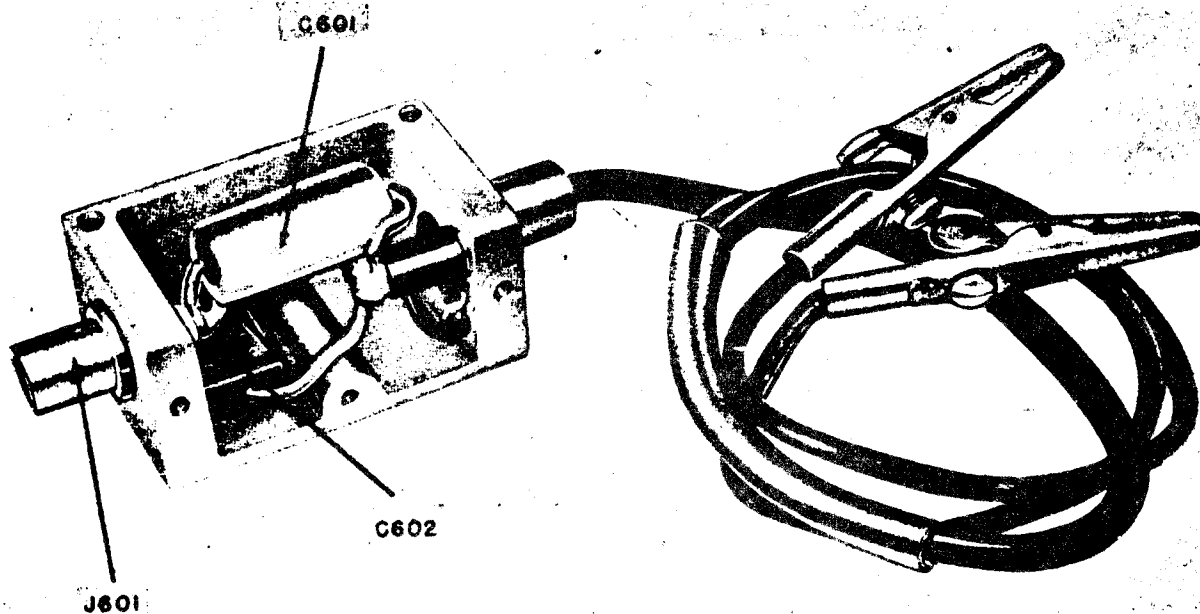

Figure 2-11. Test Lead CX-1363/U

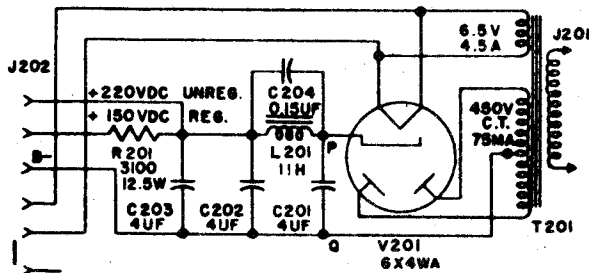

Figure 2-12. Simplified Schematic Diagram of the Power Supply PP-977/URM-25D

tically constant. If the supply voltage (points "PQ" on figure 2-12) drops, the voltage across the glow tube (V108) would tend to drop. However, the gas in the glow tube deionizes slightly and less current passes through the tube. The current passing through the series DC dropping resistor (R201) is also decreased by the amount of this current decrease in the glow tube. This would develop sufficiently smaller voltage drops across the series DC resistor to maintain the required stable 150 volts drop across the glow tube. A rise in supply voltage is similarly compensated for.

c. The regulator tube (V108) also provides for a stable output voltage when the load impedance varies. If the load increased, more current would flow through the dropping resistor (R201). This would tend to drop the 150vDC output voltage across the tube. Instead this voltage drop tendency slightly deionizes the glow tube resulting in an increase in its internal impedance. This increase in glow tube impedance, relative to the

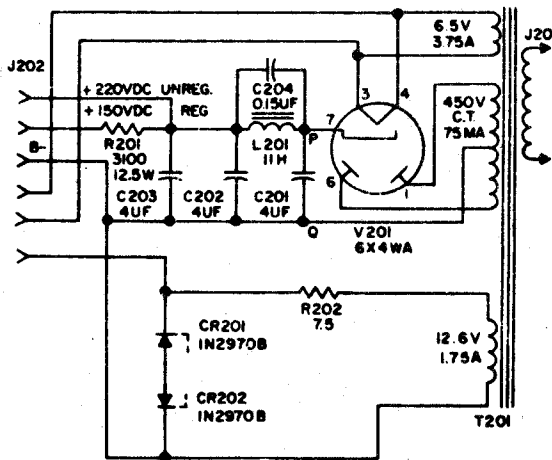

Figure 2-12A. Simplified Schematic Diagram of the Power Supply PP-977A/URM-25D

CHANGE 6

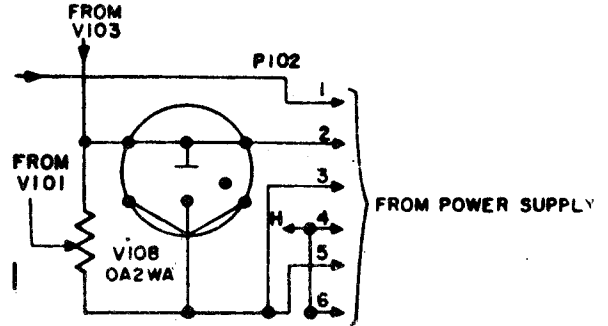

Figure 2-13. Schematic Diagram of Voltage Regulator

DC impedance of the series dropping resistor, again raises the power unit output voltage to the required 150vDC.

d. For power supply PP-977A/URM-25D (part of AN/URM-25G), the filament supply to V101 and V105 is regulated by means of Zener diodes CR201 and CR202, resistor R202, and the 12.6-volt winding on transformer T201 (figure 2-12A). The Zener diode performs a function similar to that of the regulator tube except at lower voltages. A Zener diode is operated in the reverse breakdown (or avalanche) region in which the diode maintains a constant voltage over a wide range of current. Approximately half of the voltage from the 12.6-volt winding of T201 is dropped across resistor R202. If the voltage increases, the current through CR201 or CR202 increases, increasing the voltage drop across R202, thus maintaining the voltage constant. The converse applies for decreasing supply voltages. Two diodes are used in a "back-to-back" connection so that on either half cycle of alternating current, one diode conducts in the forward direc-

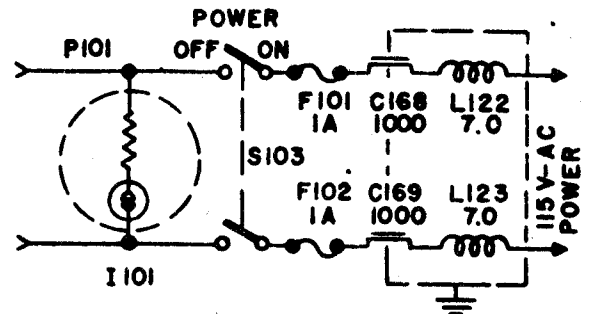

Figure 2-14. Schematic Diagram of 115V-AC Power Source

2-10A/2-10B



tion with a relatively low voltage drop while the other conducts in the reverse breakdown region. The sum of the voltage drops is equal during either half cycle.

e. The 6.5-volt filament supply (one side B-), the regulated filament supply (one side B-), the 150-volt DC output, and the 220-volt DC output are connected to the power unit output receptacle (J202). These voltages are transferred to the signal generator subchassis through power cable W103. The B- lead from J202 is not grounded to the power supply chassis but is carried to a single ground point in the audio compartment. The power supply chassis, however, is grounded to the other units of the signal generator. The reason for this separate B- ground is to eliminate RF leakage due to ground voltage gradients.

Whenever a voltage measurement is made from the signal generator, it should, therefore, be made between the test voltage point and B-, not to the chassis.

**11. OSCILLATOR FILAMENT REGULATOR
CIRCUIT (AN/URM-25H ONLY)**

a. The filament voltage (6.5V) coming from the power transformer T201 to the oscillator tube V101 (6AH6) is full wave rectified by diodes CR1 and CR2 (see Figure 6-28). This voltage is then doubled in value by the use of capacitors C1 and C2. The doubled voltage (approximately 12V) is reduced and regulated by resistors R1, R2 and CR3 to yield a constant D.C. voltage output to the oscillator filament of 6.2 volts over an input voltage range of 5.4 to 6.3 volts. This results in a relatively constant frequency output whenever the input AC line voltage varies.

SECTION 3
INSTALLATION

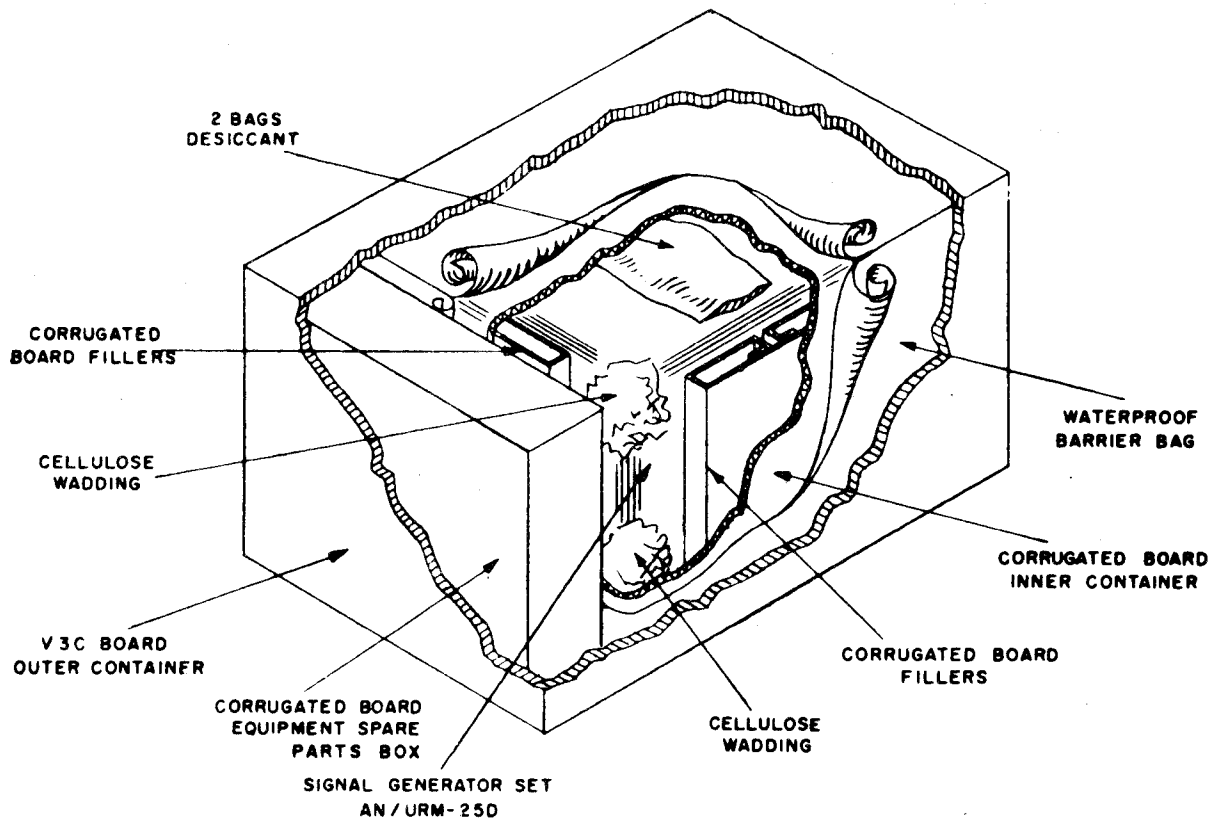

Figure 3-1. RF Signal Generator Set AN/URM-25D, Packaging Diagram

1. UNPACKING.

a. The AN URM-25D is packed in a V3C board box together with a set of equipment spares. Electron tubes are shipped in place. The Signal Generator with accessories and the set of spares are individually enclosed in separate, specially cushioned cardboard cartons. Great care should be exercised in removing these items (figure 3-1).

b. The location of the accessories in the signal generator carton is as follows (See Section 1, figure 1-1):

(1) Antenna Simulator SM-35/URM-25, (5:1) Fixed Attenuator CN-223/URM-25D, (10:1) Fixed Attenuator CN-224/URM-25D, Impedance Adapter MX-1487/URM-25D, Test Lead CX-1363/U, Coaxial Adapter UG-201A/U (P801), and instruction book will be found on the inside of the panel cover. An aluminum plate with ferrule clips is provided for mounting these units.

(2) Output cables W104, W105, W106 are also mounted on this aluminum plate.

c. Dimensions of the signal generator are shown in Figure 3-2.

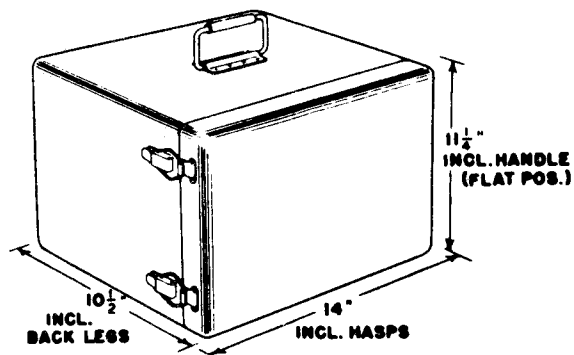

Figure 3-2. RF Signal Generator Set AN/URM-25D Outline Dimension Drawing

2. INSTALLATION.

a. The AN-URM-25D is a portable signal generator and does not require permanent installation.

b. The equipment is intended to be operated with the panel in the vertical position. Rubber supporting feet are provided for the cabinet. These feet protect the finished surface and serve to insulate the cabinet from a grounded desk. This insulation precaution, however, is not normally required.

c. The following preliminary settings and checks are required prior to placing the equipment in operation (Figure 4-1).

(1) Turn POWER switch (S103) to OFF position.

(2) Turn Carrier control (E114) and AUDIO OUTPUT control (E115) to the fully counterclockwise positions.

(3) Insert end of power cable W101-1 into the power source of 115 volt AC.

3. ADJUSTMENTS.

a. All operating adjustments are described in Section 4-OPERATION.

SECTION 4
OPERATION

1. GENERAL.

a. It is the purpose of the OPERATION section to instruct personnel in the proper use of the AN/URM-25D as a test instrument. To be thoroughly familiar with the method of operation, it is suggested that both Section 2 THEORY OF OPERATION and this section be read and studied.

b. In the development of this section, an attempt has been made to present each step in the logical sequence necessary to place the equipment in operation. If these steps are carefully adhered to, the operator will not only avoid damaging the signal generator but will be assured of a correct interpretation of the data as prescribed by the instrument. Table 4-3 is an operational summary of all front panel controls.

c. The essential details of operation and the necessary precautions to be taken are covered in this section under the following headings and paragraphs:

(1) Power Circuit Par. 2

(2) Setting the Meter Zero Par. 3
 (3) Setting Carrier Frequency Par. 4
 (4) Crystal Calibrator Par. 5
 (5) Adjusting Output Voltage Par. 6
 (6) Internal Modulation Par. 7
 (7) External Modulation Par. 8
 (8) Terminating the Signal Generator Par. 9
 (9) Coupling to the Receiver Under Test Par. 10
 (10) Use of Antenna Simulator
 SM-35/URM-25 Par. 11
 (11) Use of Variable RF Attenuator Par. 12
 (12) Use of (5:1) Fixed Attenuator
 CN-233/URM-25D Par. 13
 (13) Use of (10:1) Fixed Attenuator
 CN-224/URM-25D Par. 14
 (14) Summary of Operation Par. 15
 (15) General Instructions for Use Par. 16

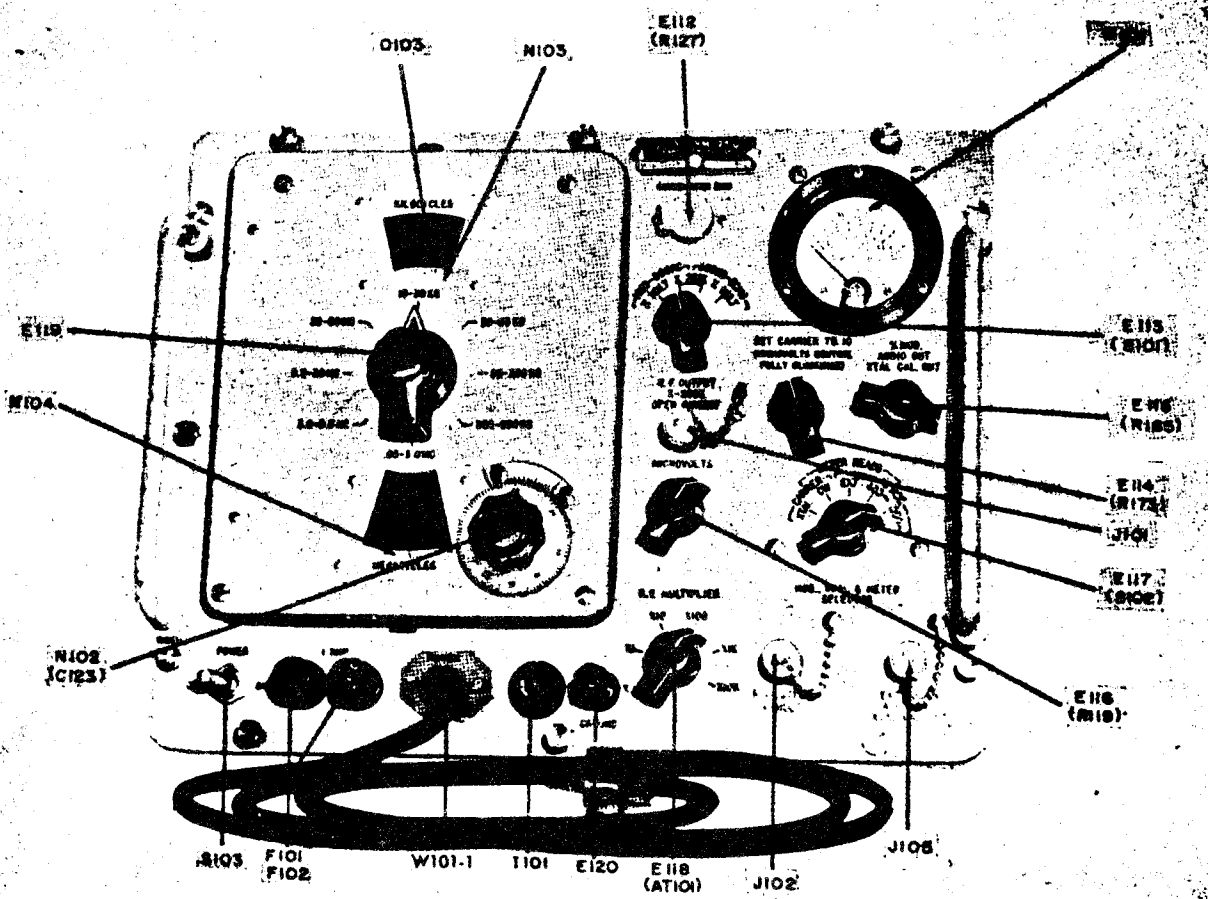

Figure 4-1. RF Signal Generator SG/URM-25D

2. POWER CIRCUIT.

a. The carrier control knob (E114) and audio output control knob (E115) should be turned fully counterclockwise before turning the POWER switch (S103) to the ON position.

b. Plug the power cable (W101-1) into the 115 AC source.

c. Turn the POWER switch (S103) to the ON position. Line voltage is now applied through the interconnecting power cable (W102) to the primary of the power transformer (T201). This is shown schematically in figure 6-24.

d. No other power switches are provided and the signal generator is now in operating condition. A minimum 15-minute warm-up period should then be allowed prior to setting the generator for use. This period permits the instrument to reach a stable operating state.

3. SETTING THE METER ZERO.

a. (1) Set the carrier control (E114) and the audio output control (E115) fully counterclockwise.

(2) Plug power cable (W101-1) into 115 volt AC power source.

(3) Turn the POWER switch (S103) to ON. Allow a 15-minute warm-up period.

(4) The meter (M101) should read zero in CW position of MOD-XTAL & METER SELECTOR.

b. If the meter does not read zero, adjust it by turning CARRIER METER ZERO control (under the cover E112), using a screwdriver.

4. SETTING CARRIER FREQUENCY.

a. Whenever setting the frequency of the signal generator, be sure that the MOD-XTAL & METER SELECTOR knob (E117) is set to the CW position and the carrier control (E114) is turned fully counterclockwise. The carrier range knob (E113) should be set to the X-MULT position of the corresponding frequency range.

b. The desired frequency is selected by setting the frequency band switch (E119) and turning the main frequency tuning dial (N102). The frequency is then read from the frequency scale (N103). If greater accuracy is required, this reading may be interpolated by utilizing the index scale of N103, and the reading indicated on the tuning dial (N102) (see par. 5c).

c. Eight frequency bands are available and can be selected by E119. A scale mask (0103) is linked to this switch so that only the band scale selected will be made visible.

d. The index scale calibrated from 0 to 1000 is located at the bottom of the frequency scale dial and is visible in all positions of the frequency band switch (E119).

e. The main tuning dial (N102) is calibrated from 0 to 100. One complete revolution of this dial will move the frequency scale (N103) 100 divisions on the index scale. The index scale (N104) and tuning dial interpolation are discussed in paragraph 5c of this section.

f. The following procedure should be used for selecting the operating frequency of the signal generator.

(1) Turn the carrier control (E114) to the fully counterclockwise position.

(2) Set the frequency band switch (E119) to the desired frequency band.

(3) Turn main tuning dial (N102) until the desired value on the frequency scale (N103) coincides with the hair-line indicator.

b. A double hairline is provided for eliminating parallax errors. The operator should read the frequency on a straight line of vision so that both hairlines appear to merge as a single line.

5. CRYSTAL CALIBRATOR.

a. GENERAL. An integral crystal calibrator (V105) is provided for checking frequency between 10 and 50 mc with an accuracy of $\pm 0.25\%$.

b. PROCEDURE.

(1) Set MOD-XTAL & METER SELECTOR to XTAL position, MICROVOLTS control fully clockwise. Adjust carrier control until meter reads "10".

(2) Connect a pair of headphones to XTAL CAL OUT jack, using cable W105 and Connector Adapter UG-684A/U. Use XTAL CAL OUT control as a volume control, if necessary.

(3) For frequencies higher than 12 mc of the 9.5-30 mc band and 32 mc of the 30-50 mc band, select the nearest megacycle (zero or null) beats on either side of the desired frequency and record the vernier dial readings at these points. The difference between these readings represents the vernier difference for a one mc spread. The vernier setting for the desired frequency may be determined by interpolation. See paragraph 5c(1) for an example of frequency interpolation.

(4) For frequencies between 10 and 12 mc of the 9.5-30 mc band and between 30 and 32 of the 30-50 mc band, set to the desired frequency on the frequency scale (see par. 4f) and record the vernier reading. Set to the nearest even megacycle frequencies on either side of the desired frequency and record the vernier readings. Calculate the proportional difference of the desired frequency reading to the difference representing a one megacycle spread. Select the megacycle (zero or null) beat nearest to each of the two even megacycle graduations and record the vernier readings. The vernier setting of the desired frequency is calculated by applying the proportional difference of the direct reading to the vernier difference of the megacycle beat readings. See paragraph 5c(3) for an example.

c. EXAMPLES OF FREQUENCY INTERPOLATION
(See figure 4-2).

(1) Assume a desired frequency of 24.2 mc.

(2) Select the zero beat closest to 24 mc. This might indicate slightly less than 670 on the index scale and 68.5 on the vernier scale (N101 and N102). The vernier reading for 24 mc is thus 668.5.

(3) Rotate the tuning dial until the zero beat nearest 25 mc is obtained. This might indicate a vernier reading of 704.1.

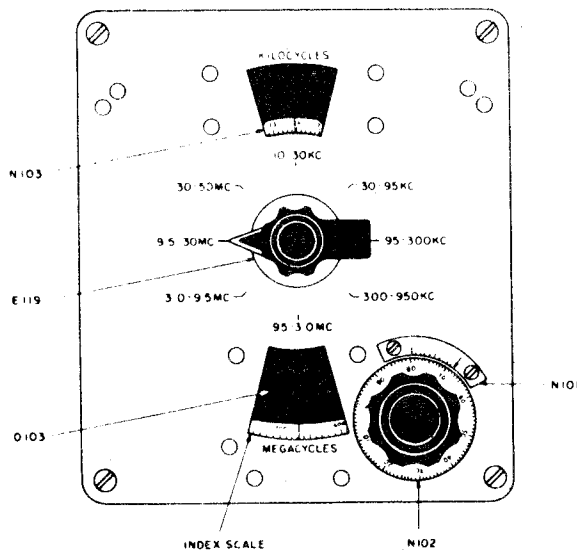

Figure 4-2. Diagram Showing Vernier Reading of Frequency Scale

(4) The vernier difference for one mc is therefore $704.1 - 668.5 = 35.6$. Since 24.2 represents 0.2 mc from the lower check point, the vernier setting for 24.2 is $0.2 \times 35.6 + 668.5 = 675.6$.

(5) Assume a desired frequency of 10.3 mc.

(6) Record the vernier readings of frequency scale settings of 10 mc, 10.3 mc and 11 mc, which might be 86.3, 110.1 and 156.2 respectively. The proportional difference of the 10.3 mc reading to the difference representing one mc is $(110.1 - 86.3) + (156.2 - 86.3) = 0.3405$. That is, the setting for 10.3 mc is 0.3405 of the scale difference between 10 mc and 11 mc.

(7) Select and record the vernier readings of the zero beats representing 10 mc and 11 mc. These might be 85.7 and 155.6. The corrected vernier setting for 10.3 mc is then $85.7 + 0.3405(155.6 - 85.7) = 109.5$.

6. ADJUSTING OUTPUT VOLTAGE.

a. PRELIMINARY SETTINGS. Before the output voltage is adjusted the signal generator controls should be set in the following positions:

(1) Carrier control and audio output control fully counterclockwise.

(2) Plug power cable into the power receptacle.

(3) Turn POWER switch to the ON position. Allow 15 minute warm-up periods.

(4) Set MOD-XTAL & METER SELECTOR knob to CW position.

(5) Carrier range knob to the appropriate position.

(6) MICROVOLTS control fully clockwise.

(7) Use frequency band switch to select desired frequency range, and set exact frequency desired on

main tuning dial. If extreme accuracy is required, follow procedures described in par. 5.

(8) Make sure meter reads zero. If not, use CARRIER METER ZERO control to zero meter. (See par. 3—SETTING THE METER ZERO).

b. ADJUSTMENTS.

(1) Advance the carrier control in a clockwise direction until meter reads "10" on the upper MICROVOLTS scale. When using the X-MULT RF OUTPUT, select the attenuation range with the RF MULTIPLIER knob and adjust the MICROVOLTS control for the desired output voltage. This voltage is determined in microvolts by multiplying the meter reading by the indicated position of E118 when the generator output cable is terminated in its characteristic impedance of 50 ohms.

(2) When changing the frequency, readjust the carrier control (E114) for a meter reading "10" with the MICROVOLTS control (E116) returned to the fully clockwise position. Select the desired output voltage by rotating the MICROVOLTS control. Do not use the carrier control for this purpose.

(3) To avoid leakage, all jacks not in use should be covered by caps.

7. INTERNAL MODULATION AND AUDIO OUTPUT.

a. INTERNAL MODULATION.

(1) Follow the procedure described in paragraph 6.

(2) Set audio output control (E115) fully counterclockwise.

(3) Set MOD-XTAL & METER SELECTOR knob (E117) to the 400 or 1000 cycle position as required.

(4) Adjust audio output control (E115) until the meter reads the desired percentage of modulation.

b. AUDIO OUTPUT (400 or 1000 cycles).

(1) Follow steps for internal modulation; except step (1).

(2) Audio voltage proportional to reading on M101 is available at EXT MOD IN jack (J105). When the meter reads "50", approximately 2.5 volts open circuit are available.

8. EXTERNAL MODULATION.

a. Follow the procedure described in paragraph 6.

b. Set MOD-XTAL & METER SELECTOR knob (117) to EXT position.

c. Connect an external audio frequency source, using an accessory cable, to the EXT MOD IN jack (J105).

d. Adjust audio output control (E115) for desired percentage of modulation on generator meter (M101). Do not modulate with frequencies above 1000 cycles for frequencies below 300 kc.

9. TERMINATING THE SIGNAL GENERATOR.

a. When the 50 ohm cable assembly (W104) is plugged into the X-MULT RF OUTPUT jack (J102) and terminated properly (50 ohms), no standing waves will be present. An impedance adapter MX-1487 URM-25D consisting of a 50 ohm composition resistor (R501), contained in a rectangular aluminum case (figure 4-3)

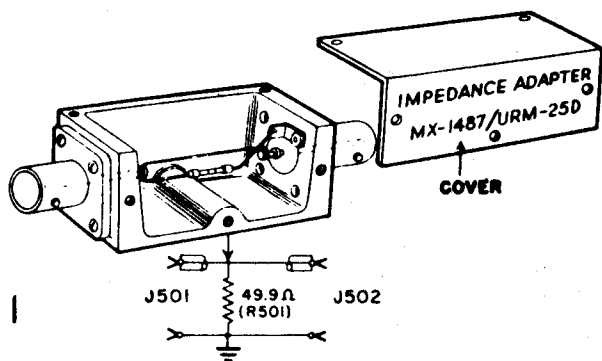

Figure 4-3. Impedance Adapter MX-1487/URM-25D

is supplied with the equipment. This unit has one UG-1094/U connector at each end and is inserted between the receiver under test and the receiver end of cable W104 when the receiver load impedance is at least ten times the generator output impedance (e.g. approximately 500 ohms).

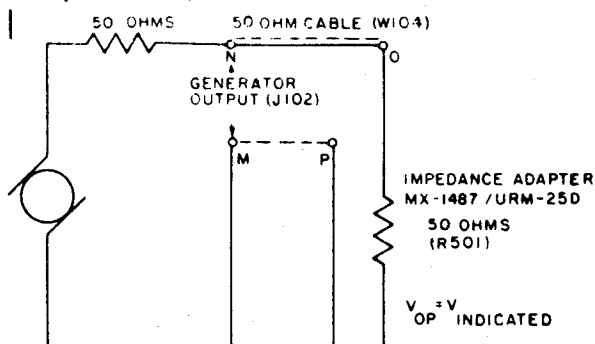

Figure 4-4. Equivalent Circuit of RF OUTPUT X-MULT (J102) with Impedance Adapter MX-1487/URM-25D added

b. It is apparent from figure 4-4 that the voltage appearing across this terminating resistor at points "OP" will be one half the open circuit voltage across the generator output at J102, represented by points

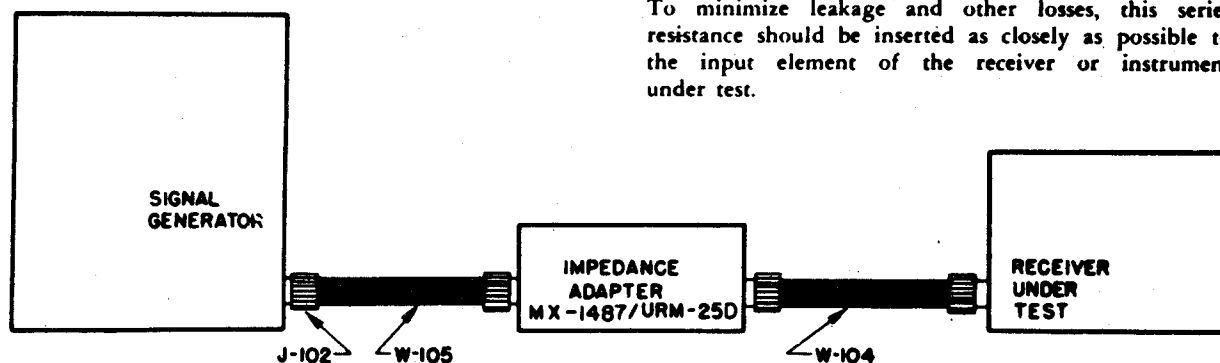

Figure 4-5. Method of Inserting Impedance Adapter MX-1487/URM-25D at J102

CHANGE 3

"MN". However, since the meter (M101) was calibrated with respect to a correctly terminated load, the reading on the meter will actually reflect the input voltage to the receiver under test. Figure 4-5 illustrates the method for inserting the impedance adapter.

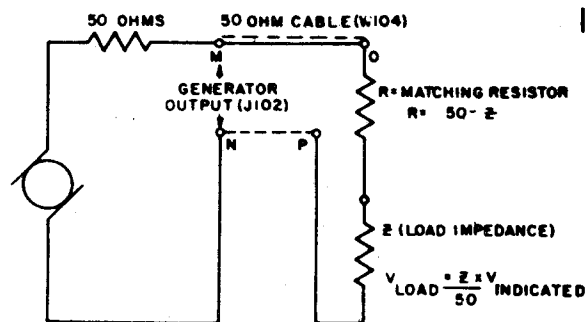

Figure 4-6. Equivalent Circuit of RF OUTPUT X-MULT (J102) with Series Matching Resistor Added

c. When the load impedance is less than 50 ohms, the impedance adapter cannot be used. In this case, a non-inductive composition resistor should be added in series with the input element at the receiver under test, so that the sum of the receiver input impedance and this resistor will be 50 ohms (figure 4-6). The total load impedance will then match the signal generator impedance at J102 and standing waves will be minimized. The actual receiver input voltage can then be calculated from the formula indicated in figure 4-6. When applying this procedure, it will probably be necessary to file down a larger standard resistor to get the precise value required. Use the Resistance Bridge ZM-4/U or equivalent to measure the resistance. For example, if the load impedance of the receiver (Z) is equal to 30 ohms, a series resistor (R) of 20 ohms must be added in series with the receiver. A meter (M101) indication of 10,000 microvolts will then represent an actual receiver input as follows:

$$E_{\text{load}} = \frac{Z}{50} \times M = \frac{30}{50} \times 10,000 = 6000 \text{ microvolts}$$

To minimize leakage and other losses, this series resistance should be inserted as closely as possible to the input element of the receiver or instrument under test.

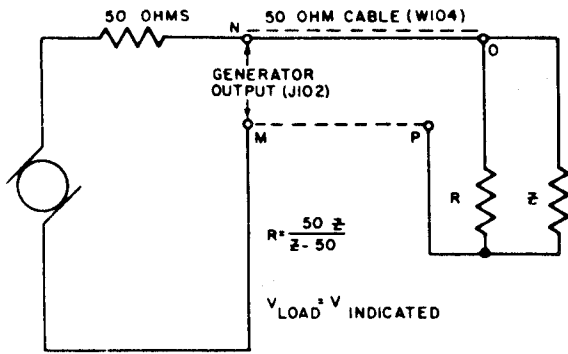

Figure 4-7. Equivalent Circuit of RF OUTPUT X-MULT (J102) with Shunt Resistor Added

shunts the load (figure 4-7). The equivalent impedance of the shunt and load should equal the generator impedance (50 ohms). The receiver input voltage will then be equal to the meter indication. For example, if the receiver input impedance (Z) is 120 ohms, select the correct shunt resistor (R) as follows:

$$R = \frac{50 \times Z}{Z - 50} = \frac{50 \times 120}{120 - 50} = \frac{6000}{70}; R = 85.07 \text{ ohms}$$

It is apparent that the meter (M101) indication will be the same as the actual input voltage to the receiver. If an accurate voltage indication is required, it will be necessary to file down a standard resistor until the desired value is obtained. Use the Resistance Bridge ZM-4 U or equivalent to determine when this value has been reached.

d. If the load impedance is considerably less than 500 ohms, but more than 50 ohms, the impedance adapter is replaced by a non-inductive composition resistor which

e. Tables 4-1 and 4-2 show the most desirable type of termination for any particular load impedance.

TABLE 4-1. REFERENCES FOR CORRECTLY TERMINATING THE GENERATOR AT J102

LOAD IMPEDANCE	METHOD	FIGURES	PARAGRAPH
Less than 50 ohms	Series Resistor	4-6	9c
50 ohms to approximately 500 ohms	Parallel Resistor	4-7	9d
500 ohms or greater	Impedance Adapter MX-1487/URM-25D	4-3; 4-4; 4-5	9a

TABLE 4-2. METHODS FOR CORRECTLY TERMINATING THE SIGNAL GENERATOR AT J102

TYPE OF INPUT	LOAD IMPEDANCE	CIRCUIT	ACCESSORY RESISTOR	VOLTAGE APPLIED TO LOAD IS:
I	LESS THAN 50 OHMS Z_1		$R_1 = 50 - Z_1$	$V_{INDICATED} \times \frac{Z_1}{50}$
II	FROM 50 OHMS TO APPROXIMATELY 500 OHMS Z_2		$R_2 = \frac{50 Z_2}{Z_2 - 50}$	$V_{INDICATED}$
III	500 OHMS OR MORE Z_3		IMPEDANCE ADAPTER	$V_{INDICATED}$

10. COUPLING THE RECEIVER UNDER TEST.

a. X-MULT RF OUTPUT JACK (J102).—For best results, the terminations principles outlined in Tables 4-1 and 4-2 should be followed when using the 50 ohm output from J102. Cables W104, W105 and W106 are provided for making the necessary connections between units and should be used as required. Coaxial adapter UG-201A U is also supplied for use in adapting the BNC connectors on the signal generator cables to a type N connector found on many receivers.

(1) At Low RF levels it may be necessary to orient the ground connections to obtain best results. For this purpose ground terminal E120 should be used.

(2) Table 4-2 lists the correct methods for terminating the signal generator at J102. These methods apply to loads which are fundamentally resistive in nature. The application principles are discussed in Section 2, par. 7

b. X-200,000 RF OUTPUT JACK (J101).—The impedance at this jack is a resistance of approximately 500 ohms shunted by the capacitance of the jack (approximately 4 mmf). Below 8 mc this jack shunt reactance has no appreciable effect on the voltage obtainable from J101. At 40 mc, however, the reactance due to the shunt capacitance is only 1000 ohms, and a 30% attenuation of signal voltage will be present at this frequency. In any event, a maximum 2 volts across a high impedance load should be available at J101 for all frequencies. It is reemphasized at this point that the termination methods outlined in Table 4-2 do not apply to this jack since the impedance at J101 is 500 ohms. When using the X-200,000 RF OUTPUT, the output voltage in microvolts is determined by multiplying the meter (M101) reading by 200,000. This will be the actual voltage across a high impedance load.

CAUTION

Care must be taken to prevent the introduction of voltages back into the attenuators or impedance adapter from the circuit under test. Currents greater than 20 milliamperes may burn out the resistances incorporated within these units. Always insert the Test Lead CX-1363/U whenever making point-to-point measurements in a receiver. This precaution is not necessary when using the antenna simulator, which contains a series capacitor.

11. USE OF ANTENNA SIMULATOR SM-35/URM-25
(See figure 4-8).

a. The Antenna Simulator SM-35/URM-25 is used when making overall measurements or tests on a receiver designed for use with a standard antenna (par. 16f of this section). The antenna simulator merely approximates the conditions that would exist had the signal been applied to the antenna circuit of the receiver and, therefore, the significant voltage is the input voltage to the simulator and not the input voltage to the receiver.

ORIGINAL

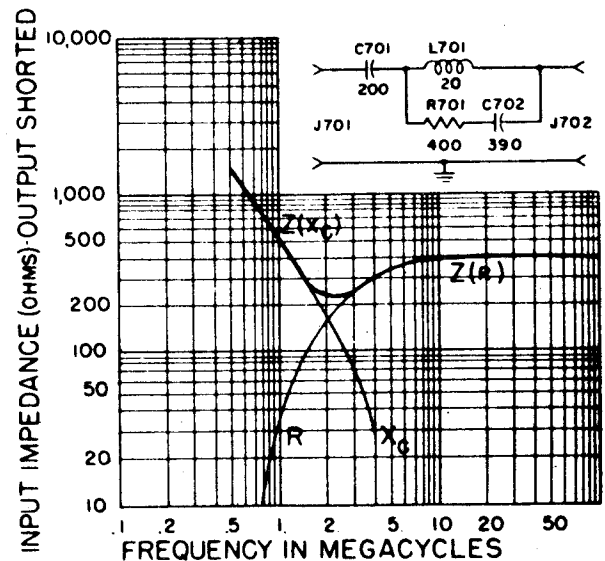

Figure 4-8. Schematic Diagram of the Antenna Simulator SM-35/URM-25 with Input Impedance Frequency Curve

b. Connect the output cable (W104) to the X-MULT RF OUTPUT jack (J102) and terminate this cable with the Impedance Adapter MX-1487 URM-25D. Connect the antenna simulator to the impedance adapter with cable W105 and to the receiver under test with cable W106.

c. It can be seen from figure 4-8 that the minimum impedance of the antenna simulator will be approximately 220 ohms at 2 mc. This impedance becomes much higher at lower frequencies and approaches 400 ohms at higher frequencies. In using the meter (M101) of the signal generator it should be realized that a 20 percent maximum error may be introduced at 2 megacycles. If greater meter accuracy is required when using the antenna simulator, the actual impedance of this unit should be calculated from figure 4-8 at the frequency, selected.

d. From the impedance curve (figure 4-8), it can be seen that the minimum impedance of the antenna simulator will be approximately 220 ohms. When using this unit, first connect one end of the Impedance Adapter MX-1487/URM-25D to the output cable (W104) and plug the other end of W104 into J102 on the signal generator. Using the auxiliary cable (W105), connect the antenna simulator to the impedance adapter. If necessary, the second auxiliary cable (W106) may then be used to connect the antenna simulator to the receiver under test.

e. In using the antenna simulator, it should be realized that the significant voltage is the input and not output voltage of the antenna simulator. The reason for this is that the antenna simulator approximates a standard antenna which forms a part of the overall sensitivity measurement of a receiver designed for use with it. For example, if the output frequency of the signal generator

is 20 mc, it can be seen from figure 4-8 that the series impedance of the antenna simulator will be approximately 400 ohms resistive. Make the necessary connections as indicated in paragraph 9 of this section. A meter indication of 10,000 microvolts represents an input voltage of 10,000 microvolts to the antenna simulator.

f. For accurate receiver output voltage indication it should be remembered that the total load impedance represented by the antenna simulator in series with the load of the instrument under test should be at least 500 ohms. From figure 4-8 it is apparent that the accuracy will be sufficiently good at frequencies above 5 mc. Below 5 mc, the impedance falls off to approximately 220 ohms and the receiver input load should be sufficiently high (approximately 280 ohms or greater) to maintain the accuracy.

12. USE OF VARIABLE RF ATTENUATOR.

a. Whenever the frequency of the signal generator is changed, reset the X-200,000 RF OUTPUT jack (J101) voltage by rotating the MICROVOLTS control (R119) fully clockwise and then rotating the carrier control (R173) in a clockwise direction until the meter reads "10". This represents two volts open circuit output from J101.

b. The step attenuator (AT101) attenuates the output from the X-MULT RF OUTPUT jack (J102) in steps of ten as indicated on the front panel by RF MULTIPLIER knob (E118). The voltage at J101 will not be affected by the position of this knob.

c. The useful output voltage from the X-MULT RF OUTPUT jack (J102) is always based on terminating this jack in its characteristic impedance (50 ohms); thus, when the output from J102 is fed to a receiver under test, with the impedance properly matched, the reading on the signal generator meter will indicate the input voltage to the receiver under test. This is discussed more fully in paragraph 9.

d. When the voltage from V103 is set at "10" on the meter, the maximum output from the X-MULT RF OUTPUT jack (J102), when correctly terminated (50 ohms), will be 0.1 volts, while open circuit voltage at J101 will be 2 volts. Adjustments in steps of 10 are obtained for each step of the attenuator (AT101) at the output from the X-MULT RF OUTPUT jack (J102) by rotating R119. The output voltage from this jack is determined in microvolts by multiplying the meter (M101) reading by the corresponding position of the RF MULTIPLIER knob (E118). Since the accuracy of all meters is expressed in terms of percentage error for full scale deflection, the technician should avoid using the meter calibrations below "2". Use the (5:1) Fixed Attenuator CN-223 URM-25D whenever a meter voltage indication in this range is required. This attenuator is discussed more fully in paragraph 13 of this section.

e. For any particular carrier frequency, once the carrier control (R173) has been rotated to give the required "10" meter indication, its setting should never be changed. The output from each attenuated step and from the X-200,000 RF OUTPUT jack (J101) is varied

by adjusting the MICROVOLTS control (R119). Whenever the generator frequency is changed, however, the carrier control must be reset to give the required "10" meter indication. This adjustment is made only after R119 has again been rotated to the fully clockwise position.

f. When R173 and R119 have been adjusted to introduce a two volt signal (M101 reads "10" and J101 unterminated) to the step attenuator (AT101), the series voltage dropping resistor (R130) reduces this voltage to 0.2 volts. The maximum output voltage available from the X-MULT RF OUTPUT jack (J102) when this jack is terminated in 50 ohms, will, therefore, be 0.1 volts. This will also be the maximum input voltage from this jack to a properly matched receiver under test. It is this voltage, under terminated conditions, that is actually indicated on M101. The MICROVOLTS control (R119) provides smooth control of the voltage applied to the step attenuator.

g. The step attenuator (AT101) is a six section ladder resistance network and its output is attenuated in six steps. With the MICROVOLTS control (R119) and the attenuator (AT101) in combination, any desired voltage between zero and 100,000 microvolts can be obtained at the X-MULT RF OUTPUT jack (J102) when the jack is terminated in its characteristic impedance (50 ohms). The input voltage to the receiver under test is thus determined by multiplying the meter (M101) reading (upper scale) by the decimal multiplier indicated by the position of the RF MULTIPLIER knob (E118). The lowest calibrated output voltage is 0.1 microvolts.

13. USE OF (5:1) FIXED ATTENUATOR CN-223/URM-25D.

a. The (5:1) Fixed Attenuator CN-223/URM-25D attenuates the output at J102 in a ratio of 5:1 when terminated in 50 ohms. It is very useful when using the meter (M101) at output levels below "2" where the instrument accuracy falls off. This applies to microvolt ranges below 20,000 mv, 2000 mv, 20 mv, 2 mv, or 0.2 mv as selected by the RF MULTIPLIER knob (E118) and MICROVOLTS control (E116). In these cases, insert the (5:1) fixed attenuator at the X-MULT RF OUTPUT jack (J102) and terminate it as outlined in Table 4-2 for the required 50 ohms. The terminated output voltage is 1/5 the voltage indicated by M101. The actual load voltage, however, will be 1/5 the meter indication only when the load impedance is exactly 50 ohms or greater than 500 ohms. For example, if a signal generator output of 20,000 microvolts into a 600 ohm load is desired, insert the fixed attenuator as follows:

(1) Connect the fixed attenuator to J102 using cable W104.

(2) Terminate the (5:1) fixed attenuator with the impedance adapter.

(3) Set the RF MULTIPLIER knob (E118) to X10K.

(4) Set MICROVOLTS control (E116) and carrier control (E114) for "10" meter reading.

(5) The input to the load will be 20,000 microvolts.

b. If the load impedance is less than 50 ohms, it can be seen from Table 4-2 that the impedance adapter cannot be used, but the output from the (5:1) fixed attenuator must be fed to the load in series with the necessary resistor. The actual load voltage will then be something less than 1/5 the meter indication. For example, if a voltage of approximately 1200 microvolts with a load of 40 ohms is desired, insert a 10 ohm noninductive resistor in series with the load and (5:1) fixed attenuator. The meter setting should be:

$$M = \frac{50}{Z} \times E_{\text{load}} \times 5 = \frac{50}{40} \times 1200 \times 5 = 150 \times 50 = \text{approximately } 7500 \text{ microvolts.}$$

c. Although this unit was designed primarily for use with a load impedance of 50 ohms, it may also be used when the receiver under test presents an impedance other than 50 ohms. In such case, it will be necessary to apply the terminating principles as outlined in paragraph 9 and in Tables 4-1 and 4-2 of this section. For example:

(1) If the load impedance is 1000 ohms, connect one end of W104 to J102 on the signal generator. Connect the other end of W104 to the fixed attenuator and terminate the fixed attenuator with the impedance adapter. The assembly is then connected to the load. A meter indication of 10,000 microvolts now reflects an actual load input voltage of 2000 microvolts.

(2) If the load impedance is 30 ohms do not use the impedance adapter. Insert a 20 ohm non-inductive resistor in series with the output of the fixed attenuator and then connect the 30 ohm load. A meter indication of 10,000 microvolts now represents an actual load voltage as follows:

$$E_{\text{load}} = \frac{Z}{50} \times \frac{M}{5} = \frac{30}{50} \times \frac{10,000}{5};$$

$$E_{\text{load}} = \frac{60,000}{50} = 1200 \text{ microvolts}$$

d. A coaxial adapter UG-201A/U is also provided with the equipment to allow for adapting the output cables type BNC connectors (i.e. UG-88 U) to a type N connector found on many receivers.

14. USE OF (10:1) FIXED ATTENUATOR CN-224/URM-25D.

a. The (10:1) Fixed Attenuator CN-224/URM-25D attenuates the output at J102 in a ratio 10:1 when terminated in 50 ohms. This unit can be used when a high degree of voltage accuracy is desired for low level outputs on 30-50 mc band. There is no need for using the 10:1 attenuator on other bands or steps higher than X1 on the RF MULTIPLIER.

Example (1) - Selecting an accurate output of 0.8 microvolts at 30 mc into a load of 500 ohms or greater.

(a) Set signal generator at 30 mc and RF MULTIPLIER at X1 range.

CHANGE 5

(b) Adjust MICROVOLTS control (E116) for reading of "8" on M101.

(c) Insert the 10:1 fixed attenuator at J102.

(d) Terminate 10:1 fixed attenuator with Impedance Adapter MX-1487/URM-25D.

(e) Feed the output from the impedance adapter to the receiver under test.

(f) Input voltage to receiver is now 0.8 microvolts.

14A. USE OF (10:1) FIXED ATTENUATOR CN-350/URM-25D (Furnished on Contract NObsr-75083 only).

Fixed Attenuator CN-350/URM-25D is an impedance matching network that permits operating R.F. Signal Generator AN/URM-25D (50-ohm output) into the 70-ohm impedance of a Navy receiver.

15. SUMMARY OF OPERATION.

In using the AN/URM-25D as a test oscillator, it will not always be necessary to apply all the procedures outlined in this section. The technician will determine by use, the precision requirements of the equipment under test. Figure 4-9 is a simplified procedure summary for the operation of the signal generator. An operational summary of the front panel controls is given in Table 4-3.

16. GENERAL INSTRUCTIONS FOR USE.

a. DETAILS.—For additional details of proper signal testing techniques, the technician is referred to the basic equipment instruction book and also standard commercial texts. However, since most commercial test procedures refer to original broadcast type receivers which differ in principle and test values from standard Naval equipments, certain details of Naval values and methods are included herein.

CAUTION

Always use the Test Lead CX-1363/U when making point-to-point tests on a receiver. Failure to do so may result in burning out a resistor in the step attenuator (AT101) or in one of the accessory units.

b. RECEIVER TESTS.

(1) GENERAL.—The presence of incidental frequency modulation in an A M signal generator may intro-

duce asymmetry in the apparent selectivity curve of the receiver being tested. This is particularly true for a very sharply-tuned circuit. The effects of frequency modulation have been kept at a minimum in the RF Signal Generator Set AN/URM-25D and should introduce no problem in receiver testing. For best results, however, the technician should perform all of the following receiver tests (except audio response) by using the unmodulated carrier signal. In order to eliminate the need for modulation, insert a high impedance DC voltmeter such as Multimeter ME-25/U or equal across the load of the second detector of the receiver. Adjustments can then be made with the meter response giving the necessary indication.

(2) SENSITIVITY.—At high radio frequencies, antenna characteristic cannot easily be reproduced, and considerable care must be taken in making receiver sensitivity tests. The voltage available at the signal generator unit output jack (J102) is always known, but it is not known at the receiver input terminals a few feet away. This latter voltage is proportional to the signal generator output voltage, but it may be larger or smaller due

to the characteristics and the termination of the "transmission line" between the instruments.

(3) SELECTIVITY.—The selectivity of a radio receiver is that characteristic which determines the extent to which the receiver is capable of distinguishing between the desired signal and disturbances of other frequencies. Selectivity is expressed in the form of a curve that gives the signal strength to produce a given receiver output at various frequencies, with the response at resonance taken as the reference. This selectivity curve is normally obtained by disabling the automatic volume control system of the receiver, setting the signal generator to the desired frequency, tuning the receiver to this frequency, and modulating the carrier signal 30 percent at 400 cycles. The carrier frequency output of the signal is then varied in steps from the frequency to which the receiver is tuned, adjusting the signal generator voltage as necessary to maintain a controlled receiver output. The unmodulated carrier method as described in paragraph 16b (1) of this section can also be used. Unless otherwise specified, the normal output is usually taken as 6 milliwatts into 600 ohms.

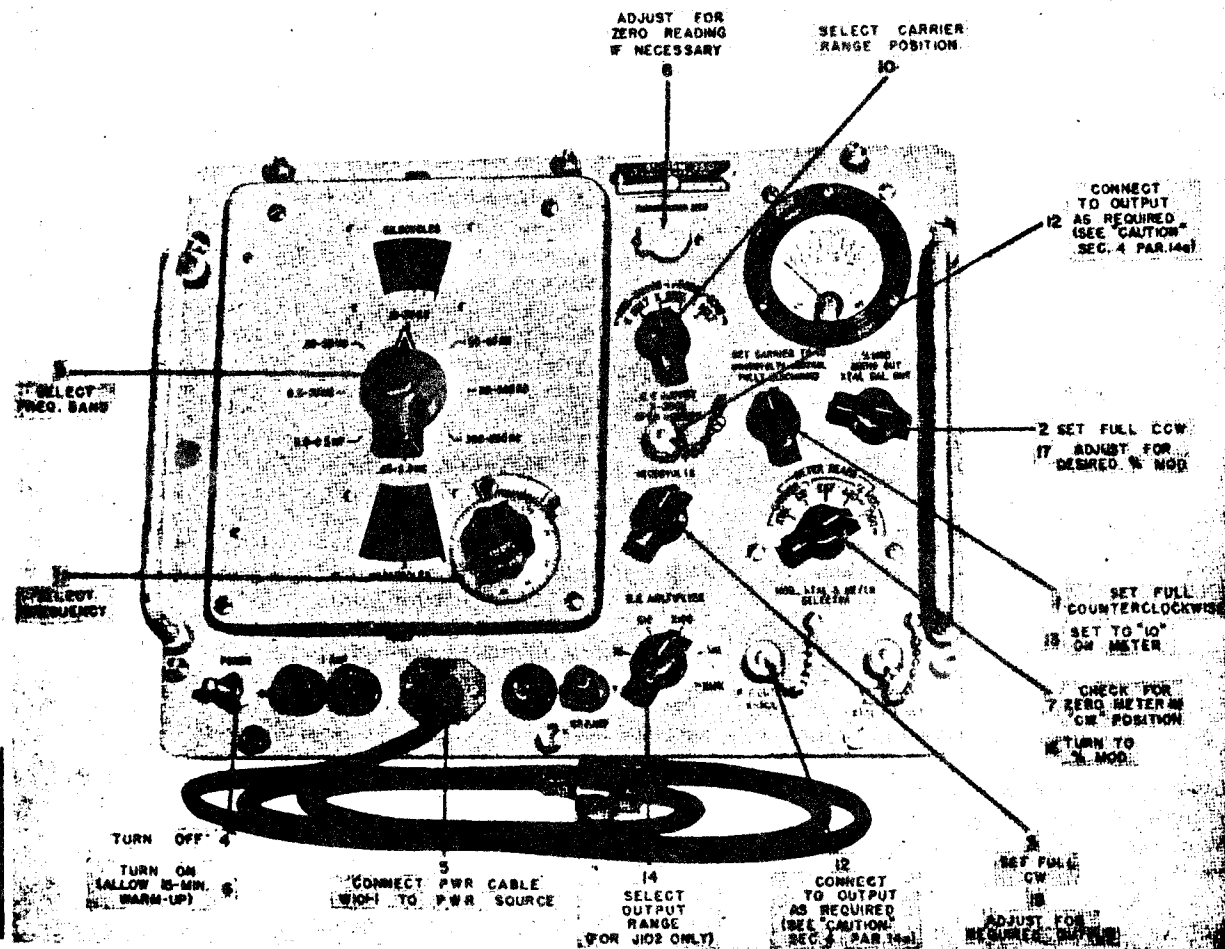

Figure 4-9. Simplified Procedure for Operating the RF Signal Generator Set AN/URM-25D

TABLE 4-3. OPERATIONAL SUMMARY OF FRONT PANEL CONTROLS
(See figure 4-1)

SYMBOL	PANEL CONTROL	FUNCTION
E113	Carrier range switch.	a. Selects carrier range: 10 to 300 kc (modulating frequencies 100 to 1000 cps) or 300 kc to 50 mc (modulating frequencies 100 to 15,000 cps).
E114	Carrier control.	Regulates level of carrier.
E115	% MOD, AUDIO OUT, XTAL CAL OUT.	a. Adjusts modulation percentage for internal and external modulation. b. Adjusts output level of internally generated 400 or 1000 cps signal. c. Adjusts level of crystal beat note at XTAL CAL OUT jack.
E116	MICROVOLTS control.	Adjusts output of signal generator.
E117	MOD-XTAL & METER SELECTOR.	a. Select one of the following modes of operation: CW, External modulation, Internal modulation 400 cps, Internal modulation 1000 cps. A fifth position, XTAL, is used for accurate frequency calibration with integral crystal. b. Switches meter for reading carrier output in XTAL and CW positions; for reading % modulation in EXT., 400 cps and 1000 cps.
E118	RF MULTIPLIER switch.	Selects desired RF output level, which is the product of meter reading and RF MULTIPLIER Factor.
E119	Frequency Band Switch.	Selects desired frequency band.
E120	Ground terminal.	Used when necessary as orienting ground with equipment under test.
F101	Fuses (one-amp).	Protect power circuit.
F102	Fuses (one-amp).	Protect power circuit.
I101	Pilot Lamp.	Lights when generator set is operating.
J101	RF OUTPUT X-200K jack.	Approximately 500-ohm, two volt open circuit RF output.
J102	RF OUTPUT X-MULT jack.	50-ohm step attenuator output.
J105	EXTMODIN - AUDIOOUT - XTAL CAL OUT jack.	a. Input for external modulation generator. b. Output for internally generated audio signals. c. Output for crystal beat note (headset).
M101	Meter.	Indicates microvolts output (upper scale), and percentage of modulation (lower scale).
N102	Main tuning dial.	Selects desired frequency.
N103	Frequency scale.	Indicates output frequency.
O103	Dial mask.	Makes visible only frequency band selected.
R127	CARRIER METER ZERO control.	Screwdriver adjustment for zeroing carrier meter.
S103	POWER switch.	ON-OFF switch for application of power.

Note

All reference to symbol designations in this section apply to the front panel diagram Figure 4-1 unless otherwise noted. Primary reference is made to the symbol designation of the front panel knob (e.g. E114) applicable to the specific circuit element (e.g. R172). The association between the knob and circuit part is shown on Figure 4-1 by indicating the corresponding circuit element designation following the knob symbol (e.g. E114 (R172)).

(4) **AUDIO RESPONSE.**—The audio response of a receiver shows the manner in which the electrical output at a dummy load depends upon the modulation frequency. In making this test connect an audio oscillator, such as the Navy Model LAJ Series, to the EXT MOD IN jack (J105). Set the MOD XTAL & METER SELECTOR knob (E117) to EXT position. Set the signal generator to the desired carrier frequency and tune the receiver under test to the signal. Adjust the signal generator until a convenient output is obtained. Observe the variation in receiver output as the modulation frequency of the signal generator is varied from 400 cycles, while keeping the degree of modulation constant at 30 percent. The results of an audio response test are expressed in the form of a curve with the ratio of actual output to 400 cycles output plotted vertically, and each corresponding audio frequency plotted horizontally. In making this test, care must be taken to avoid applying so great a signal to the receiver as to overload the output. In the event that the noise and hum level in the receiver output is appreciable it will be necessary to supply a strong enough signal from the generator to override this interfering effect.

(5) **MEASURING RECEIVER GAIN PER STAGE.**—The RF Signal Generator Set AN/URM-25D is also a useful device for measuring the gain of any particular receiver stage. This is accomplished by applying a signal to the input and output points of the stage in question and recording the signal voltage required, in either case, to give the same receiver output. The gain in db is then calculated by applying the formula:

$$\text{GAIN (db)} = 20 \log \frac{V_{\text{out}}}{V_{\text{in}}}$$

(6) **RECEIVER ALIGNMENT.**—The alignment of the intermediate frequency amplifier system of a simple receiver is usually carried out by setting up the signal generator at the proper frequency and working step by step backward through the IF circuits from the second detector to the first detector.

CAUTION

Consult the particular receiver's instruction book for details of the method applicable to that receiver. This is particularly important for wide band RF amplifiers where over coupled, regenerative or stagger tuning is used. Be sure the aligning frequency is correct. Check with a heterodyne frequency meter such as Navy Model LM or LR series to obtain greater frequency accuracy than obtainable with the signal generator below 1 mc. Above 1 mc, the crystal calibrator in the AN/URM-25D can be used to obtain an accuracy within 0.05%.

Always apply the signal generator to the grid immediately preceding the circuit under adjustment and adjust the trimmers (or variable inductances) for maximum output. In carrying out this procedure, it will of course be necessary to reduce the output of the signal generator

each time the signal is applied to the grid of a tube at lower power level. The next step is to align the radio frequency and oscillator circuits of the receiver. This is accomplished by setting the receiver dial near the high end of the band in question and applying a signal of the proper frequency from the generator to the antenna input terminals of the receiver. First adjust the RF stage shunt trimmer capacitors (or iron core inductances) for maximum receiver output, and then adjust the oscillator shunt trimmer until the receiver output is maximum. The receiver dial and signal generator are then set at the low frequency end of the receiver dial, and the oscillator series padder capacitor is adjusted for maximum output. Recheck the high frequency end of the band and repeat the above procedure as necessary.

(7) **RECEIVER ALIGNMENT ABOVE 50 MEGA-CYCLES.**—The RF Signal Generator Set AN/URM-25D can also be used for aligning receivers above 50 mc by using the second harmonic of the frequency selected. Although harmonic distortion has been kept below 10%, this still allows some second harmonics to be introduced at the X-MULT RF OUTPUT jack (J102). It must be realized that when the second harmonic is used, the signal generator meter can no longer be used as an indication of output.

c. **MODULATED OPERATION.**—In using the equipment with modulated output, it should be realized that three waves are emitted, one at the carrier frequency and at two "side bands". While either pure or modulated CW signals can be obtained from the signal generator, considerable discretion must be used in employing the modulated method of receiver testing, based on the selectivity of the receiver and the frequency of test, since the carrier and both side bands must be received in true proportion in order to obtain accurate measurements.

d. **RECEIVER OUTPUT.**—In aligning or testing a receiver, a voltmeter or output meter should be connected across the output terminals, in parallel with the proper resistance output load.

e. **RECEIVER OVERALL SENSITIVITY.**—Some radio receivers have an excess of sensitivity, such that at certain frequencies if the sensitivity, volume or gain control are advanced too far the inherent noise level is sufficient to saturate the detector or audio tubes. Accordingly, all receivers are measured and rated for both CW and MCW sensitivity on the basis of the sensitivity, volume, or gain control being adjusted so that not more than 60 microwatts of noise is present in the output with no input signal impressed. When measuring receiver overall sensitivities obtainable on the first step of the attenuator, it should be remembered that the output of the signal generator may not be attenuated equally at all frequencies to an absolute value of zero when the RF MULTIPLIER knob (E118) is set at X.1 and the MICROVOLTS control (E116) is set fully counterclockwise. The effects of stray or leakage disturbances caused by circulating currents in the case, or between panel and case, may be minimized by properly orientating the signal generator and

using the (10:1) Fixed Attenuator CN-224/URM-25D. (See Section 4, par. 14). Proper orientation of the generator with respect to the receiver will also limit the presence of undesired stray voltages. These stray effects can be ascertained by comparing the output of the receiver with the signal generator turned ON and OFF.

f. STANDARD ANTENNA ELECTRICAL CONSTANTS.—A standard antenna at low frequencies (below 1600 kilocycles) has essentially the same impedances as a series circuit of 20 microhenries, 200 microfarads, and 25 ohms. The resonant frequency is about 2500 kilocycles. The high frequency impedance is approximately 400 ohms resistive. The Antenna Simulator SM-35/URM-25 closely approximates the standard antenna (See section 4, par. 11).

g. STANDARD LEVELS.—Standard levels are as follows:

- (1) Standard output level of reference—6 milliwatts.
- (2) Standard noise level—60 microwatts.
- (3) Standard output load—600 ohms for low impedance output, or 20,000 ohms for high impedance

output, unless special impedances are provided in the receivers and noted in their instruction book.

b. VOLTMETER USED AS AN OUTPUT METER.—In making measurements when a voltmeter is used as an output meter, the following approximate wattages correspond to the voltages at the load impedances noted:

- (1) 1.9 volts at 600 ohms
11.0 volts at 20,000 ohms 6 milliwatts
- (2) 0.19 volts at 600 ohms
1.1 volts at 20,000 ohms 60 microwatts
- (3) .77 volts at 600 ohms
4.5 volts at 20,000 ohms 1 milliwatt
- (4) For receivers provided with output meters having a zero level of 6 milliwatts — minus 20 decibels equal 60 microwatts.
- (5) For receivers provided with output meters having a zero level of 60 microwatts — plus 20 decibels equal to 6 milliwatts.

SECTION 5

PREVENTIVE MAINTENANCE

1. ROUTINE MAINTENANCE CHECK CHART.

The construction of the RF Signal Generator Set AN/URM-25D is such that preventive maintenance measures will be limited. Periodic testing of the equipment to determine if it is in proper working order should be performed in accordance with the step-by-step procedure given in Table 5-1 ROUTINE CHECK CHART. If the signal generator is used frequently (several times a week), these charts should be made prior to use. Otherwise they should be made weekly. All symbol designations given in Table 5-1 refer to Front Panel Diagram, Figure 4-1 in Section 4 OPERATION unless otherwise specified.

Note

THE ATTENTION OF MAINTENANCE PERSONNEL IS INVITED TO THE REQUIREMENTS OF CHAPTER 67 OF THE BUREAU OF SHIPS MANUAL OF THE LATEST ISSUE.

2. FUSE FAILURE.

Symptoms of fuse failure and fuse location are given in Tables 5-2 and 5-3.

CAUTION

Never replace a fuse with one of higher rating unless continued operation of the equipment is more important than probable damage. If a fuse burns out immediately after replacement, do not replace it a second time until the cause has been corrected.

3. LUBRICATION.

All gears and moving shafts should be lubricated periodically with Aero Lubriplate manufactured by Fish Bros., Newark, N.J.

TABLE 5-1. ROUTINE CHECK CHART

WHAT TO CHECK	HOW TO CHECK	PRECAUTIONS AND REMARKS
1. Installation.	<p>Before connecting the power cable (W101) to the signal generator, make sure the equipment is properly set up in accordance with instructions given in Section 3-INSTALLATION.</p> <p>a. POWER switch (S103) in OFF position.</p> <p>b. Carrier control (114) fully counterclockwise.</p> <p>c. Audio output control (E115) fully counterclockwise.</p> <p>d. MICROVOLTS control (E116) fully clockwise.</p>	See that all the cables and wires are in good condition and that electrical connections are properly made.
2. Power Supply.	<p>Set controls as follows:</p> <p>a. Carrier control (E114) fully counterclockwise.</p> <p>b. Audio output control (E115) fully counterclockwise.</p> <p>c. POWER switch (S103) to ON position.</p>	The indicator lamp (I101) and frequency scale lamps (E121 and E122) should light. If they do not, check front panel fuses (see Table 5-3) and lamps.
3. Meter Check.	<p>a. Set carrier control (E114) fully counterclockwise.</p> <p>b. Throw POWER switch (S103) to ON position.</p>	If the meter does not read zero in the CARRIER position, R127 requires adjustment. (See Section 4, figure 4-1.

TABLE 5-1. ROUTINE CHECK CHART (Continued)

WHAT TO CHECK	HOW TO CHECK	PRECAUTIONS AND REMARKS
	<p>c. Allow 15 minutes warm up period.</p> <p>d. Set MOD XTAL & METER SELECTOR knob E117 to CARRIER position.</p> <p>e. Meter should read zero.</p>	
4. Carrier Frequency.	<p>Set controls and switches as follows:</p> <p>a. Carrier control (E114) to full counterclockwise position.</p> <p>b. MICROVOLTS control (E116) to full clockwise position.</p> <p>c. MOD XTAL & METER SELECTOR knob (E117) to CARRIER.</p> <p>d. Carrier range knob (E113) to corresponding band position.</p> <p>e. POWER switch (S103) to ON.</p>	<p>a. Meter (M101) should move up-scale as carrier control (E114) is rotated in a clockwise direction.</p> <p>b. Meter pointer should read "10" in all positions of the frequency band switch (E119), when the carrier control is advanced in a clockwise direction.</p>
5. Modulation Frequency.	<p>Set controls and switches as follows:</p> <p>a. Carrier control (E114) fully counterclockwise.</p> <p>b. Audio output control (E115) fully counterclockwise.</p> <p>c. MOD XTAL & METER SELECTOR knob (E117) to 400 cycles.</p> <p>d. Carrier range knob (E113) to corresponding band position.</p> <p>e. POWER switch (S103) to ON.</p>	<p>a. When audio output control (E115) is rotated clockwise, the meter should reach at least 50% modulation.</p>

TABLE 5-2. SYMPTOMS OF FUSE FAILURE

INDICATOR (I101) AND SCALE (E121 AND E122) LAMPS OF SIGNAL GENERATOR	ALL ELECTRON TUBES	METER M101	OPEN FUSE	VALUE (AMPS)	COMMENTS
None light	Filaments off	No reading	F101	1	Check also power supply, cables, connectors, etc. and the POWER switch (S103).
None light	Filaments off	No reading	F102	1	

TABLE 5-3. FUSE LOCATIONS

SYMBOLS	LOCATIONS	PROTECTS	AMPS	VOLTS
F101 F102	<p>1. Physically located in signal generator front panel fuseholders (XF101) and (XF102). See figure 4-1.</p> <p>2. Electrically located in primary of power transformer T201. See figure 6-24.</p>	Primary of power transformer (T201).	1.0	250
			1.0	250

FAILURE REPORTS

A FAILURE REPORT must be filled out for the failure of any part of the equipment whether caused by defective or worn parts, improper operation, or external influences. It should be made on Failure Report, form NAVSHIPS 383, which has been designed to simplify this requirement. The card must be filled out and forwarded to BUSHIPS. Full instructions are to be found on each card.

Use great care in filling the card out to make certain it carries adequate information. For example under "Circuit Symbol" use the proper circuit identification taken from the schematic drawings, such as T-803, in the case of a transformer, or R-207, for a resistor. Do not substitute brevity for clarity. Use the back of the card to completely describe the cause of failure and attach an extra piece of paper if necessary.

The purpose of this report is to inform BUSHIPS of the cause and rate of failures. The information is used by the Bureau in the design of future equipment and in the maintenance of adequate supplies to keep the present equipment going. The cards you send in, together with those from hundreds of other ships, furnish a store of information permitting the Bureau to keep in touch with the performance of the equipment of your ship and all other ships of the Navy.

This report is not a requisition. You must request the replacement of parts through your Officer-in-Charge in the usual manner.

Make certain you have a supply of Failure Report cards and envelopes on board. They may be obtained from the nearest District Printing and Publication Office.

Figure 6-1. Failure Report

The figure shows two overlapping forms. The top form is titled "FAILURE REPORT - ELECTRONIC EQUIPMENT" and includes fields for "CHECK ONE" (with checkboxes for "CIRCUIT SYMBOL", "CIRCUIT IDENTIFICATION", "TYPE SYMBOL AND NAME OF FAILURE UNIT", and "TYPE SYMBOL AND NAME OF FAILURE UNIT") and "FAILURE OCCURRED IN" (with checkboxes for "OVERHEAT", "VIBRATION", "HANDLING", "INSTALLING", and "REPAIR OF FAILURE AND REPAIR").

The bottom form is titled "ELECTRONIC EQUIPMENT FAILURE REPORT (346)" and includes a "TYPE WHICH FAILED" section with checkboxes for "CIRCUIT SYMBOL", "CIRCUIT IDENTIFICATION", "TYPE SYMBOL AND NAME OF FAILURE UNIT", and "TYPE SYMBOL AND NAME OF FAILURE UNIT". It also includes a "FAILURE OCCURRED IN" section with checkboxes for "OVERHEAT", "VIBRATION", "HANDLING", "INSTALLING", and "REPAIR OF FAILURE AND REPAIR".

SECTION 6

CORRECTIVE MAINTENANCE

1. THEORY OF LOCALIZATION.

a. The first step in maintenance or repair is to determine definitely that a defective condition exists. If the equipment is not operated correctly, certain indications of trouble might be presented when there is actually nothing wrong with the equipment. The technician should be thoroughly familiar with Section 4, OPERATION, of this book before attempting to analyze the indicated defect.

b. After a positive determination is made that the generator is defective, the first step in trouble shooting is to localize the trouble, that is, decide which circuit of the complete system is not functioning as it should. Once the analysis has been narrowed down to the defective circuit, it becomes a relatively simple process of making voltage and resistance checks to locate the faulty circuit part (eg. resistor, capacitor, etc).

c. The chief parts of the signal generator which are subject to wear or deterioration are electronic tubes and switches. In addition the carrier oscillator inductances may vary slightly and require recalibration as a result of aging or excessive temperature variations. (See Table 6-1 - FREQUENCY CALIBRATION DATA).

2. TEST EQUIPMENT FOR MAKING REPAIRS AND TROUBLE SHOOTING.

The technician may find a wide variation of applicable test equipment to use in making repairs or for trouble shooting on the RF Signal Generator Set AN/URM-25D. However, to achieve the best results in accordance with the characteristic of the signal generator, the following test equipments or their equivalents are recommended for use:

- a. Navy Model LM Series Crystal Calibrated Frequency Indicating Equipment.
- b. Navy Model LR Series Combined Heterodyne Frequency Meter and Crystal Controlled Calibration Equipment.
- c. Signal Generator TS-535/U.
- d. Resistance Bridge ZM-4/U.
- e. Multimeter ME-25/U Series.
- f. Oscilloscope OS-8/U, Navy Model OBL or OBT Series Cathode Ray Oscilloscope.
- g. Multimeter AN/PSM-4, TS-352/U, Navy Model OE Series Receiver Analyzing Equipment.

3. SYSTEM TROUBLE SHOOTING.

a. In employing any systematic method for trouble shooting, the methods and procedures followed by the technician will vary greatly. Any method employed is satisfactory as long as it will produce accurate results with the greatest expediency.

b. To assist the electronics technician in applying him-

self to the maintenance problems of the RF Signal Generator Set AN/URM-25D, a trouble symptoms chart and two trouble shooting tables are listed in this section. The first, Table 6-2 - TROUBLE SYMPTOM CHART is a listing of some common trouble symptoms with suggested checks for locating the defect; the second, Table 6-3 - GENERAL TEST PROCEDURES FOR LOCALIZING TROUBLE, is a systematic procedure for determining the unit or component which is the source of trouble; the third, Table 6-4 - SUGGESTED TESTS FOR LOCATING THE SPECIFIC TROUBLE gives some hints that may be applied in finding the specific part that may be defective.

4. TUBE OPERATING VOLTAGES AND CURRENTS.

Electron tube operating voltages and currents under normal operating conditions are given in Table 6-5 TUBE OPERATING VOLTAGES AND CURRENTS, located near the end of this section.

5. TUBE SOCKET ELECTRICAL MEASUREMENTS.

a. As a further aid in maintenance work, figure 6-15 SIGNAL GENERATOR VOLTAGE AND RESISTANCE CHART will be found near the end of this section. This chart lists diagrammatically the voltage and resistances measured from all tube socket connections to ground.

b. As is indicated by the footnotes to this chart, all measurements were made with a 20,000 ohms per volt DC meter, Navy Model OE Series, and a 1000 ohm per volt AC meter such as Multimeter AN/PSM-4, TS-352, J Series or equivalent.

6. WINDING DATA.

Complete winding data for all wire-wound units (except resistors) in the AN/URM-25D is given in Table 6-7 WINDING DATA.

7. EXTERIOR AND INTERIOR VIEWS OF UNITS.

To assist the technician doing maintenance work in locating the positions of the various coils, capacitors, resistors, switches, etc., comprising the signal generator, there will be found in this section additional photographic illustrations. They show every part of the RF Signal Generator Set AN/URM-25D with the corresponding symbol designation indicated. These will facilitate the easy and quick identification of all parts. Table 6-8 - CROSS REFERENCE BETWEEN SYMBOL NUMBER AND FIGURE LOCATION gives the figure in which these parts are identified.

8. REMOVING THE SIGNAL GENERATOR AND POWER SUPPLY FROM THE CABINET.

a. REMOVING THE RF SIGNAL GENERATOR SG-85/URM-25D - Since this is a precision instrument,

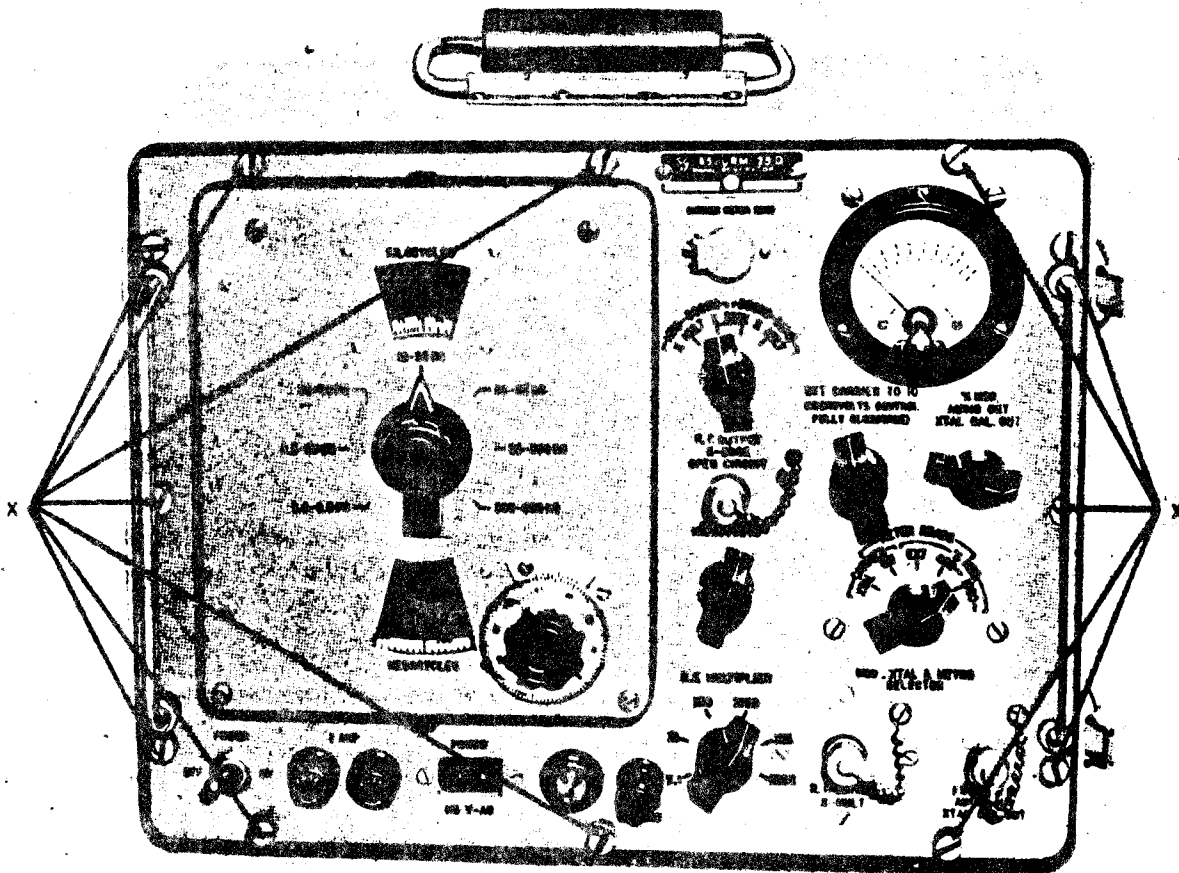

Figure 6-2. Front Panel View for Removal of RF Signal Generator SG-85/URM-25D from Cabinet

great care should be taken in removing the RF Signal Generator from the cabinet to make repairs. Before attempting to disassemble the unit, be sure that the equipment is disconnected from the power source. Adhere carefully to the following procedure:

- (1) Disconnect the power cable (W101-1).
- (2) Loosen the twelve captive screws (x) located around the outer edge of the panel (figure 6-2).
- (3) Gently pull the generator chassis about eight inches from the cabinet, using the lifting handles provided on the front panel. The generator unit cannot be completely removed since the interconnecting power cable (W102) and output power cable (W103) are still connected to the power supply sub-chassis.
- (4) Remove the output power supply connector (P102) and the AC input connector (P101) from the power supply sub-chassis. The generator sub-assembly can now be removed. The power supply sub-chassis will remain in the cabinet.

b. REMOVING THE POWER SUPPLY PP-977/URM-25D.

- (1) To remove the power supply, take out the four binding head screws (Y) located on the bottom of the

cabinet. There are also four screws on the rear of the cabinet which must be removed (figure 6-3).

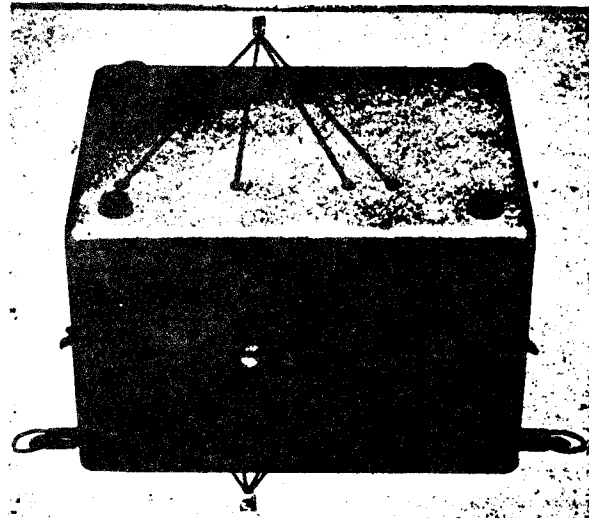

Figure 6-3. Rear Bottom View for Removal of Power Supply PP-977/URM-25D from Cabinet

(2) With the signal generator and power supply sub-assemblies removed from the cabinet, the equipment can again be connected for use and testing by applying the following procedure (figure 6-4):

(a) Insert interconnecting power cable plug (P101) into the power supply input receptacle (J201) and P102 into J202.

(b) Insert the power cable (W101-1) into the AC source.

WARNING

Voltages up to 450v will be exposed when the signal generator is being tested outside the cabinet. Exercise great care in handling the instrument under these conditions.

9. REMOVAL AND REPLACEMENT OF PARTS.

a. Whenever repairs are made involving the removal or replacement of any component part, the part removed should be marked or tagged for identification and its exact position in the equipment carefully noted and recorded so that when the same or new part is replaced the equipment will be precisely as before. This precaution is particularly necessary when RF components, such as coils and capacitors, are replaced. The location of these parts with respect to associated components will play an important role in the performance of the equipment.

b. Whenever any parts are replaced by new ones always use the identical type listed and described in Section 7, PARTS LIST, Table 7-4. If such parts cannot be obtained, substitute only similar parts with equivalent electrical and mechanical characteristics. If precision parts are not available and it is absolutely necessary to use the equipment, a temporary substitute of approximate value may be inserted. This is not recommended as a normal procedure and the exact replacement should be ordered. The unsatisfactory substitute should be removed as soon as the exact replacement is received.

10. REMOVAL OF OSCILLATOR BRACKET ASSEMBLY.

a. Remove two screws on the right side of the signal generator when viewed from the rear of the unit. Remove the small nut holding the bus bar on the edge of the bracket.

b. Slowly pull out the oscillator bracket assembly so as not to break any leads or connections which are soldered to other parts of the oscillator compartment.

c. Make a note of all connections before unsoldering. Replace defective parts, resolder all connections, and mount the bracket assembly in place with the two screws and nut.

11. REMOVAL OF CRYSTAL CALIBRATOR BRACKET ASSEMBLY.

a. Partially remove the power cable mounting plate, then remove two screws from the bottom of the signal

generator which hold the crystal calibrator bracket assembly in place.

b. Remove the bracket assembly slowly to prevent damaging any parts or lead connections.

c. Make a note of all connections before unsoldering. Replace defective parts, resolder all connections and mount the bracket assembly in place with the two screws. Replace the power cable mounting plate.

12. REMOVAL OF AUDIO COMPARTMENT ASSEMBLY.

a. Remove the three knobs titled as follows:

- (1) SET CARRIER TO 10
- (2) %MOD - AUDIOOUT - XTALCALOUT
- (3) MOD-XTAL & METER SELECTOR

b. Remove the cover from the EXT MOD IN-AUDIO OUT-XTAL CAL OUT jack.

c. Disconnect the two leads from the rear of the meter (M101).

d. Remove four screws on the front panel which will permit removal of the audio compartment assembly.

e. Note all connections before unsoldering. Replace defective parts and resolder all connections properly.

f. If the meter is to be replaced, remove three screws on the front panel, then remove the meter. Mount a new meter in place with the three screws.

g. Re-mount the audio compartment assembly with the four screws. Connect the two leads to the rear of the meter.

h. Replace the cap and all knobs in their proper position.

13. REMOVAL OF STEP ATTENUATOR.

a. Remove the RF MULTIPLIER knob and the cap from the RF OUTPUT X-MULT jack. Remove the four screws positioned around the jack on the front panel.

b. Disconnect the lead which is connected to the buffer-amplifier compartment and remove the step attenuator.

Note

Note the position of the gear teeth before removing the step attenuator.

c. Replace any defective resistors or gears if damaged.

d. Mount the step attenuator in place, and position the gear teeth properly. Replace the four screws, the knob, and cap.

14. REPLACING RF OSCILLATOR CIRCUIT COMPONENTS.

a. The RF oscillator frequency determining components L101 through L108 and C101-1 through C118 should not normally be replaced in the field unless the necessary calibrating instruments are available. These instruments include RF heterodyne frequency meters that cover from 10 kc to 50 mc with an accuracy of at least 0.05% (e.g. Navy Model LR and Signal Generator TS-535/U).

b. Changing the oscillator tube should not normally

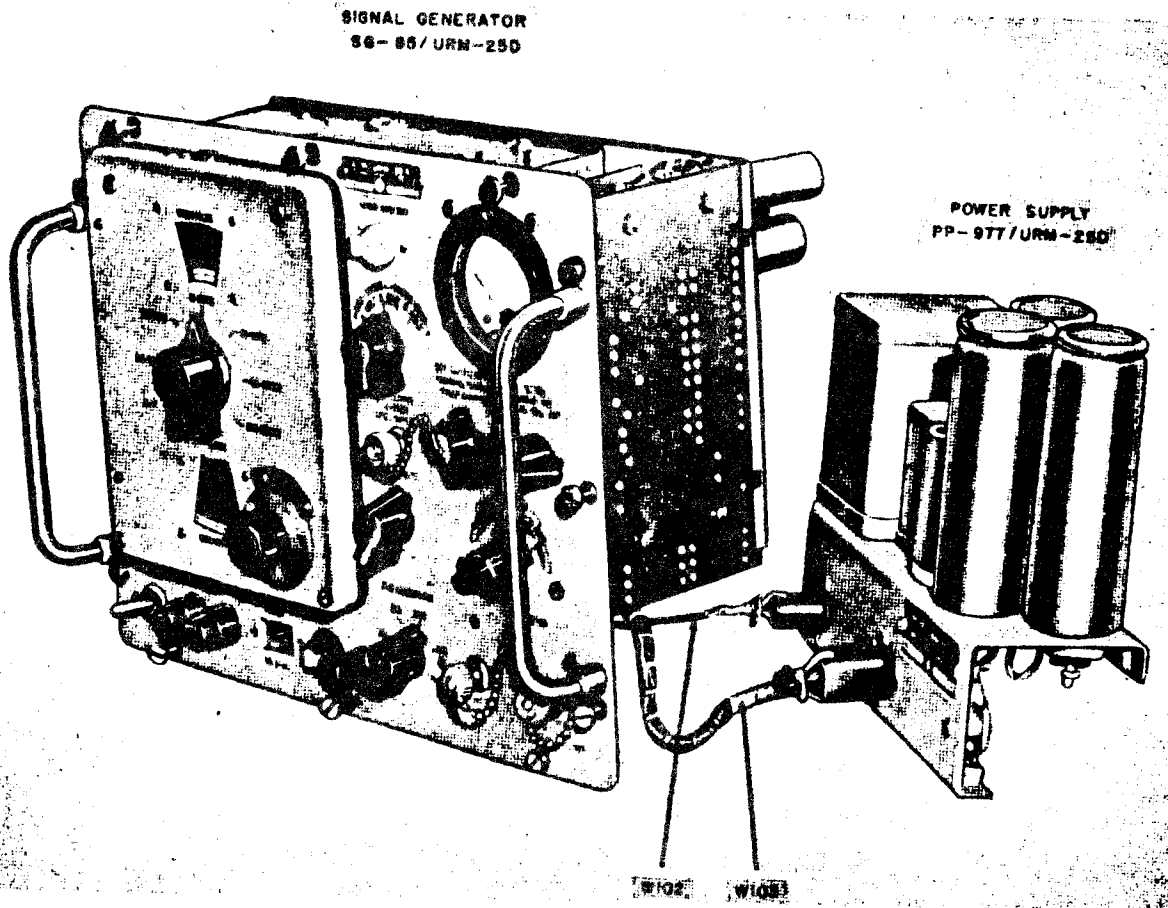

Figure 6-4. RF Signal Generator SG-85/URM-25D and Power Supply PP-977/URM-25D Connected Outside Cabinet for Testing

cause error in calibration. However, when replacing the oscillator tube, the signal generator should be recalibrated as soon as the necessary test equipment is available (e.g. Navy Model LR and Signal Generator TS-535/U).

15. REPLACING BUFFER AND AMPLIFIER CIRCUIT COMPONENTS

(See figures 6-5, 6-6, and 6-7).

The buffer amplifier compartment is located between the carrier oscillator and audio compartments. It contains the buffer stage (V102), output amplifier stage (V103), and VTVM (V104) circuits, in addition to the MICROVOLTS control ((R119), carrier range switch (S101), and the meter zero control (R127). It is sometimes necessary to remove this unit when making repairs. This removal should be accomplished in the following manner.

a. Remove the buffer-amplifier and oscillator compartment cover plate.

b. Remove carrier range switch knob (E113) and MICROVOLTS control knob (E116) located on the front panel of the signal generator.

- c. When necessary, label all leads before unsoldering.
- d. Remove the mounting nuts which attach the buffer-amplifier unit inside the compartment.
- e. The buffer-amplifier can now be removed.

16. READJUSTMENT OF FREQUENCY CALIBRATION

(See figure 6-12).

a. WHEN TO CALIBRATE. The signal generator should be recalibrated whenever oscillator coils or capacitors are replaced and whenever it is suspected that the frequency error is in excess of $\pm 1\%$. This recalibration is accomplished by adjusting the applicable coils and trimmers as discussed in paragraph 17 of this section.

b. LIMITATIONS OF CRYSTAL CALIBRATOR (V105) FOR FREQUENCY RECALIBRATION. The use of the integral crystal calibrator for interpolative calibration was discussed in Section 4, par. 5. When used in this manner, the accuracy of the signal generator is increased from the rated $\pm 0.5\%$ to $\pm 0.25\%$ at frequencies above 10 mc. Since the crystal calibrator operates on the harmonic generation principle, it is limited as a recalibrating device when some circuit defect or replace-

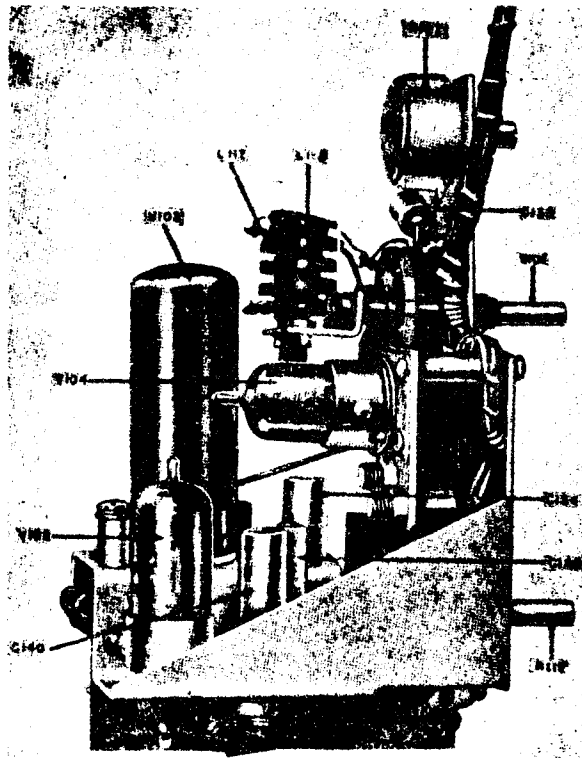

Figure 6-5. Side View of Buffer - Amplifier Unit with Tubes in Position

ment introduces a frequency error greater than 1%. For example; if for some reason, the frequency error at 50 mc is -2%, the frequency scale will read 50 mc when the actual frequency is 51 mc. Since zero beats occur at both 50 mc and 51 mc (1 mc apart), it will be difficult to determine which point corresponds to 50 mc. Similarly, at lower frequencies, (down to 1 mc), the combination of signal generator and crystal calibrator harmonics may introduce beats at intervals closer than 1 mc. Since the accuracy of the signal generator is better than $\pm 0.5\%$, there will be no problem in determining the applicable beat for interpolative calibration. When recalibrating the instrument because of errors greater than 1%, however, the instruments recommended in the following paragraph should be used to avoid any possible confusion.

c. RECOMMENDED TEST EQUIPMENT FOR RECALIBRATING.

- (1) Navy Model LR Frequency Meter.
- (2) Set of earphones for monitoring zero beat.

Note

Figure 6-11 shows the locations of the trimmers and inductances that may require readjustment. Make sure that only the parts relevant to the frequency band being calibrated are adjusted. Follow the calibration procedure and do not turn screws indiscriminately.

ORIGINAL

17. FREQUENCY CALIBRATION PROCEDURE

(See figure 6-12 and Table 6-1).

a. GENERAL.

(1) When the frequency error of the signal generator is in excess of 1%, it will be necessary to recalibrate the instrument. In making the necessary adjustments, the RF Signal Generator SG-85/URM-25D must first be removed from the cabinet. Interconnecting cables are of sufficient length so as not to require the removal of the Power Supply PP-977/URM-25D sub-chassis. Follow the procedure outlined in Section 6, par. 6, for removing the signal generator unit.

(2) Over the frequency range covered by Bands A through H (10 kc through 50 mc), each oscillator coil has connected across it a trimmer capacitor for adjusting the total capacitance associated with it. Each corresponding coil also has a movable dust iron slug by means of which the inductance of that coil can be adjusted to the required value.

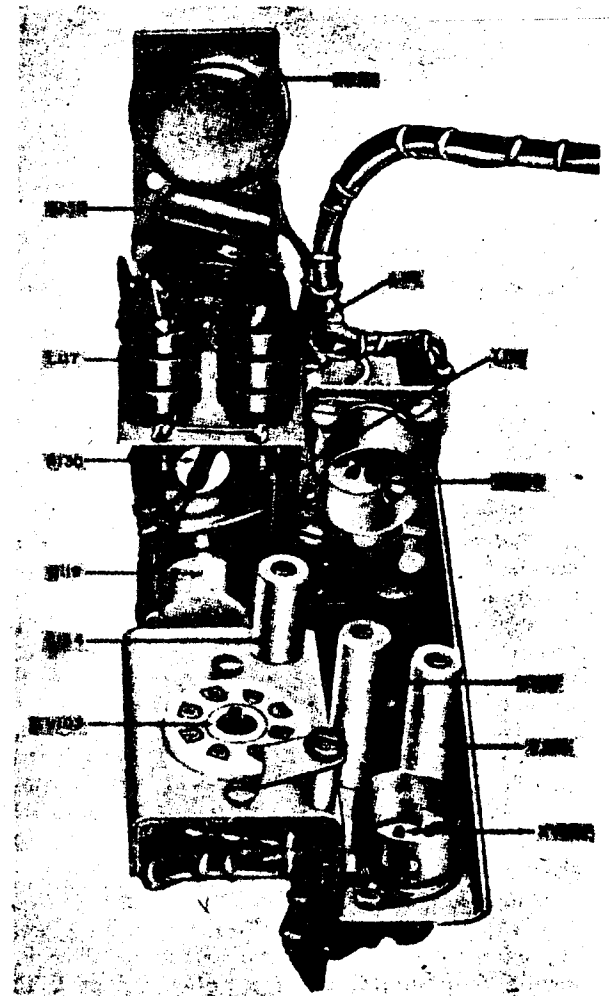

Figure 6-6. Rear View of Buffer - Amplifier Unit with Tubes Removed

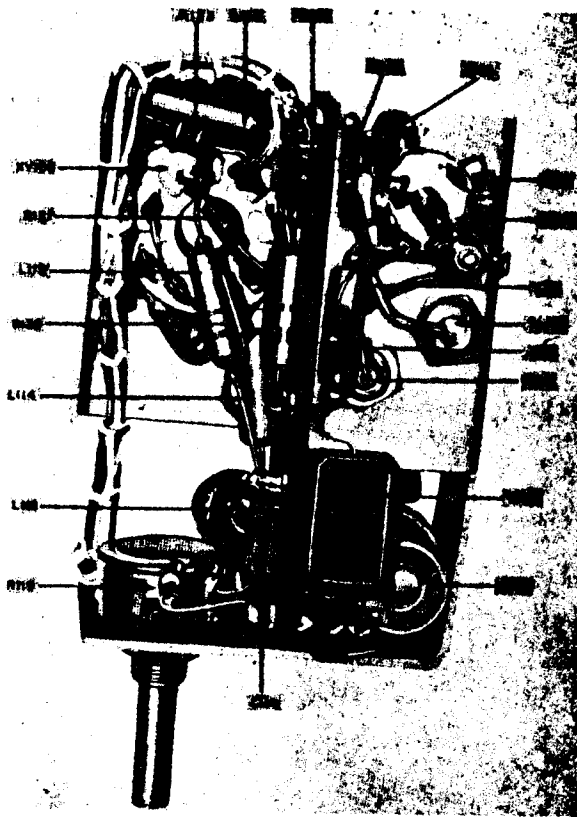

Figure 6-7. Bottom View of Buffer - Amplifier Unit

(3) In using the heterodyne frequency meters referred to in paragraph 16 of this section, connect the output test cable (W104) to the heterodyne frequency meter. Plug a pair of earphones into the audio output of the frequency meter. Make the necessary capacitance and inductance adjustments while listening for a zero beat on the earphones.

(4) For calibrating frequency ranges below 100 kc, use the Signal Generator TS-535/U. Feed the output from the RF Signal Generator Set AN/URM-25D and Signal Generator TS-535/U to the horizontal and vertical inputs, respectively, of the oscilloscope, such as Oscilloscope OS-8/U, Navy Models OBL or OBT series (See figure 6-12). Adjust the frequency of the RF Signal Generator Set AN/URM-25D to the same frequency as the Signal Generator TS-535/U as indicated by a zero-shaped Lissajou pattern. Be sure to calibrate the Signal Generator TS-535/U according to its instruction book before using it as a standard in this procedure.

b. FREQUENCY CALIBRATION CHART. Table 6-1 is a chart for calibrating frequency and the necessary adjustment to be made on all bands. When calibrating frequency, follow the points and procedures therein contained.

c. CALIBRATION PROCEDURE (See figure 6-12 and Table 6-1)

(1) To make the necessary RF trimmer and coil adjustments, it will be necessary to remove the top shield plate from the carrier oscillator compartment side of the casting which provides access to the trimmer condenser. It is also necessary to remove the screw plug from the casting to provide access to the oscillator coil. Identification of the appropriate coil and condenser is not necessary, since the correct components are automatically aligned with the access holes for each frequency band.

(2) The recalibration process consists of (a) adjusting the inductance for frequency calibration at the low-frequency end of the range, (b) adjusting the corresponding trimmer capacitor for a calibration point at the high end of the range, (c) rechecking the low end plus coil adjustment if necessary, (d) rechecking the high end if adjustment in step c is required, and (e) checking the center portion of range selected.

(3) After the adjustment has been made, replace the plate and plug and recheck calibrations. If the calibrations have been changed when this plate is replaced, readjust the applicable trimmer or core to compensate for this effect.

CAUTION

After the necessary adjustments have been made, on the upper and lower ends of the band being calibrated, the corresponding calibrations should be correct throughout the frequency range. If not, the main tuning capacitor (C123) may be defective. One common way that this variable capacitor becomes defective is through "plate bending." Never bend the plates of the main tuning capacitor (C123) in attempting to make an adjustment.

18. CALIBRATING THE VOLTMETER

(See figure 6-16 and 6-17)

a. General. In the course of operating the equipment it may be discovered that the meter (M101) does not indicate what it should. This can readily be determined by applying the procedures outlined in Section 5, Table 5-1-ROUTINE CHECK CHART, and by making the necessary adjustments outlined in this paragraph. The RF output should be checked and recalibrated, if necessary, whenever any component parts are replaced in the VTVM (V104) circuitry, following the procedure outlined in subparagraph c. of this paragraph.

Note

All voltmeter adjustments (T.69 and R172) are of the screwdriver type and are located in the audio compartment. Figure 6-16 identifies these controls.

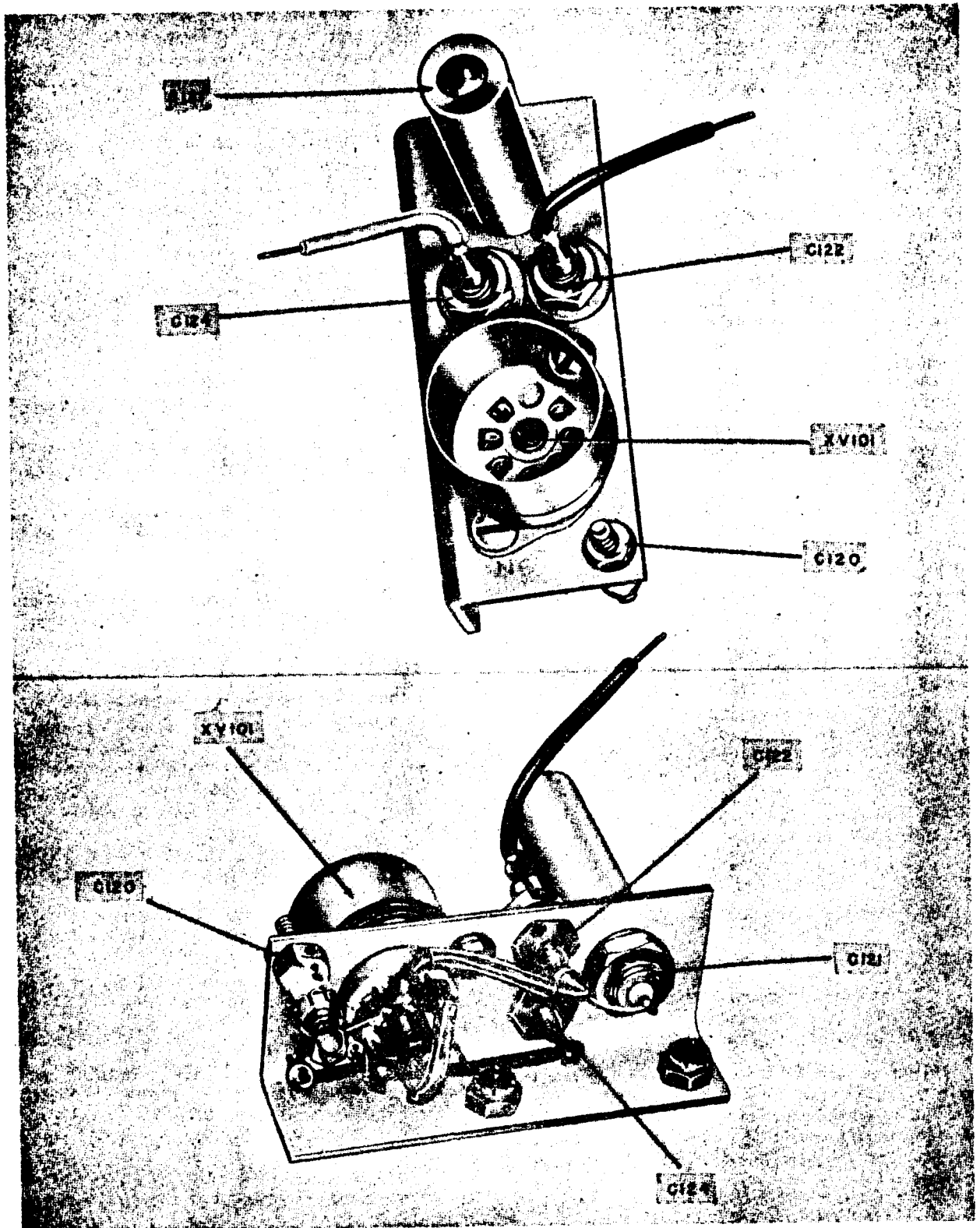

Figure 6-8. Top and Bottom Views of Carrier Oscillator Bracket

ORIGINAL

b. ZERO ADJUSTMENT.—If the meter (M101) does not read zero in the carrier position of the MOD-XTAL & METER SELECTOR switch (S102), when the carrier control (R173) and audio output control (R165) are set fully counterclockwise, make this adjustment:

(1) Set carrier control (R173) and audio output control (R165) to the fully counterclockwise positions (zero carrier and zero modulation).

(2) Set the MOD-XTAL & METER SELECTOR switch (S102) to the carrier position. The output from (V103) is now applied to the cathode of the VTVM tube (V104A). Since the carrier control (R173) was set for zero signal output (fully counterclockwise), there should be no voltage applied to the cathode of the tube (V104A), and the meter (M101) should still indicate zero. However, if a reading other than zero is reflected by the meter, adjust the CARRIER METER ZERO control (R127) until a zero meter reading is obtained. This adjustment compensates for the contact potential that may be present across the VTVM (V104).

(3) Set the MOD-XTAL & METER SELECTOR switch (S102) to the % MOD position. The output from (V107) is now applied to the crystal unit (CR101, CR102). Since the % MODULATION control (R165) was set to the fully counterclockwise position, there should be no voltage applied to the crystal unit.

c. RF OUTPUT VOLTAGE CALIBRATION (upper meter scale). RF output voltage calibration should be done only with the help of an RF power measuring set (bolometer). In case such an instrument is not available, an approximate method is given below.

(1) Turn the MICROVOLTS control (R119) to the fully clockwise position.

(2) Set the carrier control (R173) to the fully counterclockwise position.

(3) Set MOD-XTAL & METER SELECTOR switch (S102) to the carrier position.

(4) Set frequency at 100 kc.

(5) Place an electronic voltmeter, such as Multimeter ME-25/U or equal, between one center contact of the X-200,000 RF OUTPUT jack (J101) and ground.

(6) Rotate the carrier control (R173) in a clockwise direction until 2.0 volts are indicated on the test meter. The signal generator meter (M101) should read "10" on the upper scale. This represents 2.0 volts output when the X-200,000 RF OUTPUT jack (J101) is open circuited.

(7) Adjust the RF sensitivity control (R172) until the signal generator meter (M101) reads "10" on the upper scale when the test meter reads 2.0 volts.

d. PERCENTAGE MODULATION CALIBRATION (lower meter scale) — (See figure 6-14).

(1) Set carrier frequency at 100 kc.

(2) Set MOD-XTAL & METER SELECTOR switch (S102) to the % MOD. position (400 cycles per second).

(3) Set carrier range switch (S101) to the "10" kc-300 kc position.

(4) Feed the output from the X-MULT RF OUTPUT jack (J102) to the vertical input of a test oscilloscope.

(5) Place a graduated celluloid screen over the face of the oscilloscope.

(6) With the RF MULTIPLIER knob (E118) and MICROVOLTS control (R119), adjust the modulated signal amplitude to cover approximately 75 percent of the oscilloscope face.

(7) Adjust the audio output control (R165) on the front panel until 50 percent modulation is indicated on the oscilloscope, figure 6-14.

(8) Adjust the sensitivity control (R169) until the meter (M101) also indicates 50 percent on the modulation scale (lower scale).

(9) Adjust the audio output control (R165) on the front panel until 30 percent modulation is indicated on the oscilloscope.

(10) Check the reading of the meter.

(11) If necessary readjust R169 until 30 percent and 50 percent readings are both as accurate as possible, favoring the 30 percent adjustment since this value is used most often.

19. CALIBRATING THE STEP ATTENUATOR (AT101).

a. The voltage attenuation of the step attenuator (AT101) should be checked whenever a resistor in this unit is replaced. Use the (10:1) Fixed Attenuator CN-224/URM-25D and a radio receiver such as Navy Model RBA Series or equivalent for making this check as follows:

(1) Set the RF Signal Generator Set AN/URM-25D for 100 kc carrier frequency with 30% modulation at 400 cycles.

(2) Connect the (10:1) Fixed Attenuator CN-224/URM-25D to J102 and terminate it with the Impedance Adapter MX-1487/URM-25D.

(3) Connect the impedance adapter output to the RBA (or equivalent) receiver.

(4) Adjust the output of the signal generator for a reading of "10" on M101.

(5) Set the RF MULTIPLIER knob (E118) one range above the range in which the resistor was replaced.

(6) Connect a voltmeter such as Multimeter ME-25/U series or equivalent across the output of the RBA receiver.

(7) Tune the receiver to the frequency (100 kc) of the signal generator and record a reference receiver output as indicated by the multimeter.

(8) Reset the RF MULTIPLIER knob (E118) to the attenuation range in question (next lower range).

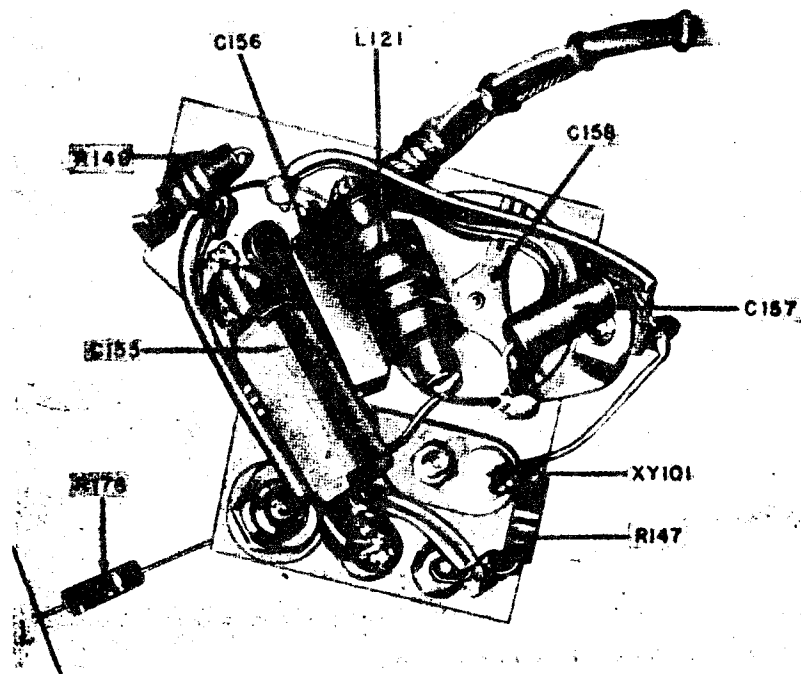
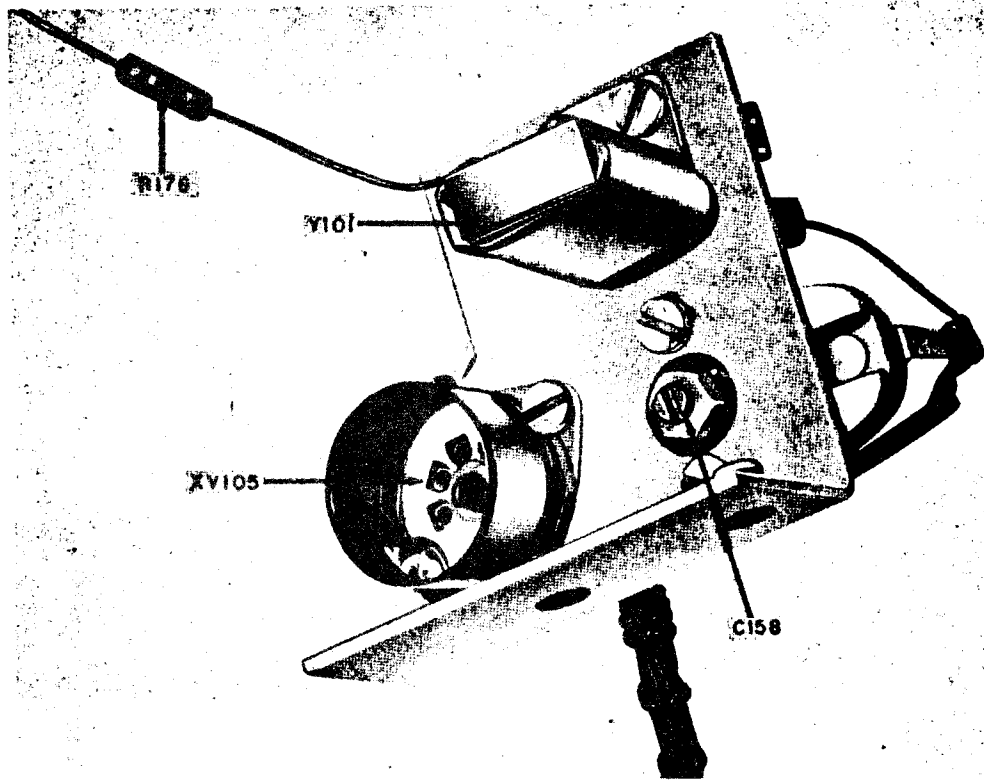

Figure 6-9. Top and Bottom Views of Crystal Calibrator Bracket

(9) Remove the (10:1) Fixed Attenuator CN-224/URM-25D and connect the signal generator output at J102 to the Impedance Adapter MX-1487/URM-25D.

(10) Advance the MICROVOLTS control (E116) in a clockwise direction for a meter reading of "10."

(11) The receiver output should be within $\pm 2\%$ as was indicated in step 7 above. If it is not, the resistor on this range should be replaced.

Note

Use a very hot soldering iron when replacing

resistors in the step attenuator (AT101). Apply the iron to the solder surface for a very short period of time. Too long a period of heating may cause the precision resistors to change in value.

b. Whenever it is suspected that the step attenuator ratios are not correct, the procedures outlined in paragraph 19a above may be used as a check. A more complete analysis of step attenuator troubles is given in Table 6-4 - CHART OF SUGGESTED TESTS FOR LOCATING THE SPECIFIC TROUBLE, paragraph 6.

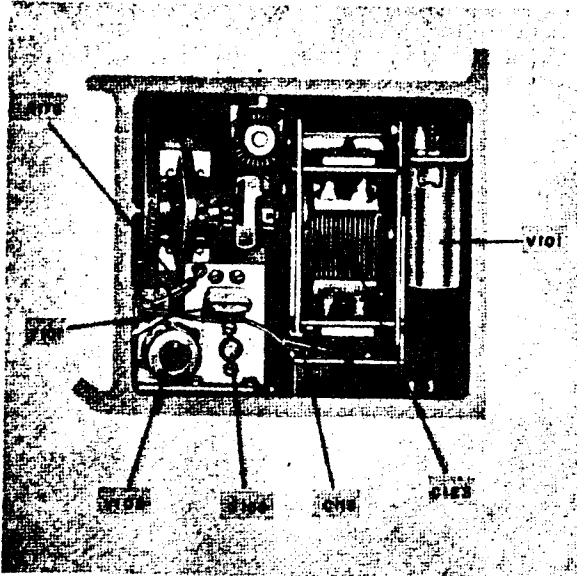

Figure 6-10. Rear View of Oscillator Compartment

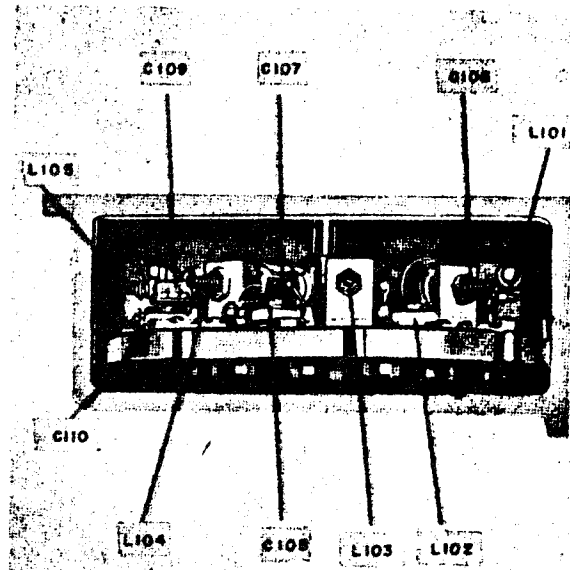

Figure 6-11. Rear View of Turret Selector Switch

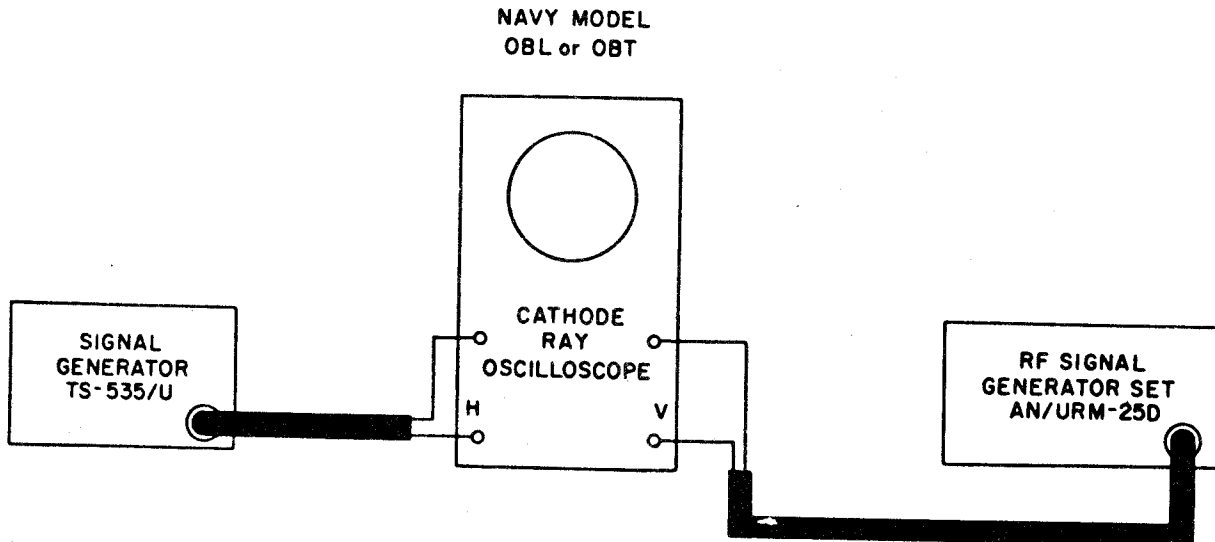

Figure 6-12. Method for Calibrating the RF Signal Generator Set AN/URM-25D at Frequencies Below 100 Kilocycles

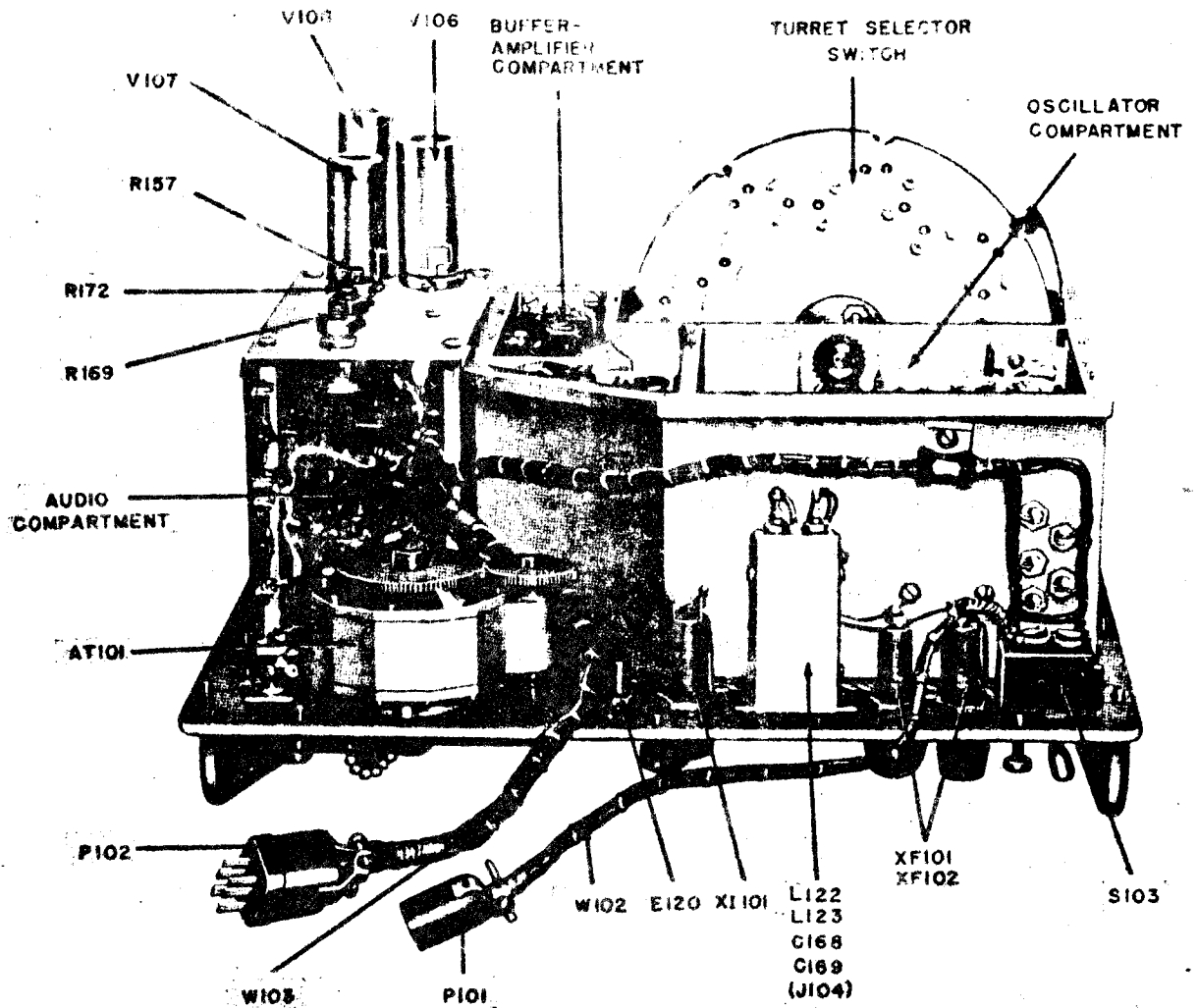

Figure 6-13. Bottom View of Signal Generator SG-85/URM-25D

TABLE 6-1. FREQUENCY CALIBRATION DATA

FREQUENCY RANGE	LOW END — ADJUST INDUCT.		HIGH END — ADJUST CAP.	
	FREQ.	COIL	FREQ.	CAP.
A	10 Kc	L101	30 Kc	C102
B	30 Kc	L102	90 Kc	C104
C	100 Kc	L103	300 Kc	C106
D	300 Kc	L104	900 Kc	C108
E	1.0 Mc	L105	3.0 Mc	C110
F	3.0 Mc	L106	9.0 Mc	C112
G	10 Mc	L107	30 Mc	C114
H	30 Mc	L108	50 Mc	C116

ORIGINAL

TABLE 6-2. TROUBLE SYMPTOM CHART

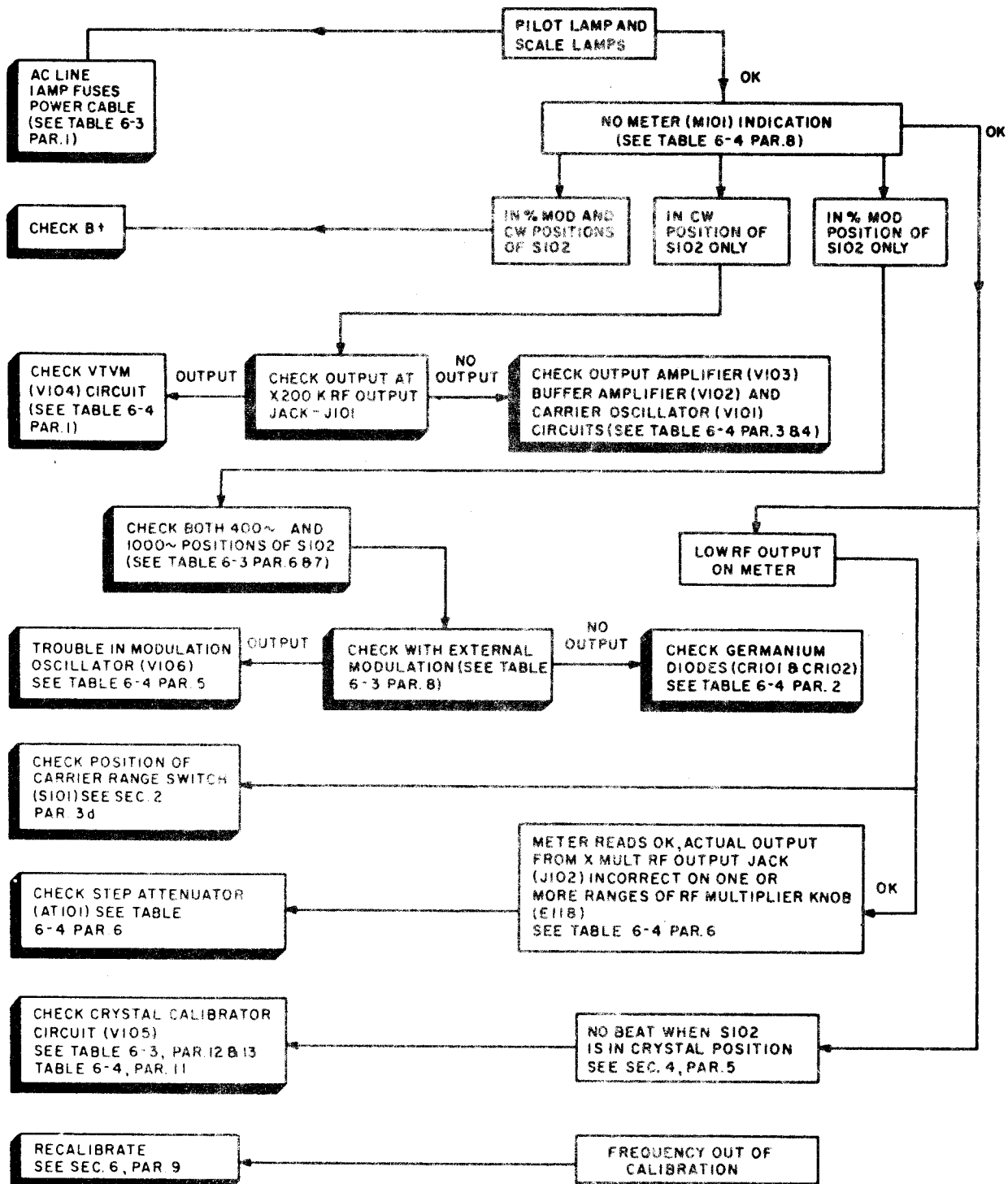

TABLE 6-3. CHART OF GENERAL TEST PROCEDURE FOR LOCALIZING TROUBLE

Note: The CARRIER (R173) and % MOD, AUDIO OUT, XTAL CAL OUT (R165) controls should always be turned fully counterclockwise before turning power on.

LOCALIZATION AND TYPE OF TROUBLE	SUGGESTED METHOD FOR LOCALIZING TROUBLE
<p>POWER SUPPLY. (See par. 11 of this table for additional check.)</p>	<p>1. Make sure the indicating lamp (I101) or scale lamps (E121 and E122) have been made to light, as evidence that the 115-volt supply mains, fuses, and at least a part of the power supply system is in working order. If none of these lamps light, see Table 6-4, par. 7 on POWER SUPPLY.</p>
<p>VTVM</p>	<p>2. Set the signal generator controls in the following position:</p> <ul style="list-style-type: none"> a. POWER switch (S103) OFF. b. MOD-XTAL & METER SELECTOR switch (S102) at CW. c. Carrier range switch (S101) at applicable range. d. Carrier control (R173) in extreme counterclockwise position. e. % MOD - AUDIOOUT - XTALCALOUT control (R165) in extreme counterclockwise position. f. Frequency band switch (E119) set for any one of eight ranges.
<p>VTVM</p>	<p>3. Turn the POWER switch (S103) ON. The meter needle should be at the first line on the left. If it can not be zero set see Table 6-4, par. 1 on VTVM circuit trouble.</p>
<p>CARRIER OSCILLATOR, VTVM, BUFFER and OUTPUT AMPLIFIER</p>	<p>4. Advance the carrier control (R173) slowly in a clockwise direction. The meter needle should move up scale correspondingly. If it does, the VTVM, carrier oscillator (at least one range), power supply, buffer and output amplifier are functioning.</p> <p>5. Set the frequency band switch (E119) successively for each range to see if operation (as in par. 3 above) is obtained for all ranges. If it is, the carrier oscillator and buffer and output amplifier are probably functioning. Operation on some bands and not on others probably indicates a defect in the carrier oscillator (see Table 6-4, par. 4 on CARRIER OSCILLATOR); since the buffer and output amplifiers are untuned and should respond at all frequencies if they respond at one.</p> <p>6. If, in par. 4 and 5 above, the meter does not move up scale, turn the MOD-XTAL & METER SELECTOR switch (S102) to the 400 cycle position. Slowly advance the % MOD-AUDIO OUT-XTAL CAL OUT control (R165) in a clockwise direction. If the meter now moves up scale, it indicates that there is trouble in the carrier oscillator, VTVM, or buffer and output amplifier circuits (see Table 6-4 Sections on CARRIER OSCILLATOR, VTVM, BUFFER and OUTPUT AMPLIFIER.) This also indicates that the modulation oscillator and modulation crystal voltmeter circuits are functioning.</p>
<p>MODULATION OSCILLATOR</p>	<p>7. If the meter responds to the tests in par. 4, but not in par. 5 above, the trouble is in the modulation oscillator or modulation crystal voltmeter.</p> <p>8. With the MOD-XTAL & METER SELECTOR switch (S102) at EXT position, carrier range switch (S101) at applicable range, apply an external-audio signal (1000 cycles) to the EXT MOD IN-AUDIO OUT-XTAL CAL OUT jack (J105). Slowly advance the % MOD-AUDIO OUT-XTAL CAL OUT control (R165) in a clockwise direction. If the meter now moves up scale, it indicates that the trouble is in the modulation oscillator.</p>

TABLE 6-3. CHART OF GENERAL TEST PROCEDURE FOR LOCALIZING TROUBLE (Continued)

LOCALIZATION AND TYPE OF TROUBLE	SUGGESTED METHOD FOR LOCALIZING TROUBLE
MODULATION CRYSTAL VOLTMETER	9. If the meter still does not respond to the % MOD-AUDIO OUT-XTAL CAL OUT control (R165), feed the output signal from the X-200K RF OUTPUT jack (J101) to a test oscilloscope. Set the carrier frequency at 100 kc. Place the MOD-XTAL & METER SELECTOR switch (S102) in the CW position. Advance the carrier control (R173) in a clockwise direction until a reading of "10" is obtained on the upper meter scale. With the external modulation applied as in par. 8 above, the modulated pattern should appear on the oscilloscope (figure 6-12). If it does, the trouble was in the modulation crystal voltmeter.
STEP ATTENUATOR (AT101) OR OUTPUT CABLES	10. If the meter responds to the above tests in a satisfactory manner, but there is still no output voltage at the end of output cable (W104), the trouble is in the attenuator (AT101) or output test cable (see Table 6-4, par. 6 and par. 10)
POWER SUPPLY	11. If no meter response or output voltage is obtained from the foregoing tests, the trouble is probably in the power supply (see Table 6-4, par. 7).
CRYSTAL CALIBRATOR	12. Turn MOD-XTAL & METER SELECTOR switch (S102) to XTAL position. Connect a set of earphones to EXT MOD IN-AUDIO OUT-XTAL CAL OUT jack (J105) using 5" cable (W105) and Connector Adapter UG-201/U. Tune signal generator to some even multiple of 1 mc and listen for zero beat. 13. If it is determined, from previous steps, that RF output is present at J101 and if no zero beat is heard at J105, then the crystal calibrator circuit (V105) is defective. (See Table 6-4, par. 11).

TABLE 6-4. CHART OF SUGGESTED TESTS FOR LOCATING THE SPECIFIC TROUBLE

Note: The carrier control (R173) and % MOD - AUDIOOUT - XTALCALOUT control (R165) should always be turned fully counterclockwise before turning power on.

LOCATION AND TYPE OF TROUBLE	SUGGESTED METHOD FOR LOCALIZING TROUBLE
1. VTVM CIRCUIT (V104). a. INOPERATIVE.	Measure the circuit associated with V104, according to figure 6-15, "SIGNAL GENERATOR VOLTAGE AND RESISTANCE CHART", until defect is located.
b. METER (M101) ZERO ADJUSTMENT.	(1) The inability to zero set the meter can only be observed when S102 is in the CW or XTAL position. (2) If the meter cannot be zero adjusted (carrier control set to maximum counterclockwise position, power on) by means of the CARRIER METER ZERO (R127). (a) Replace 5726 (V104) tube. (b) Check DC voltage on R127 and R125. (c) Make checks suggested in 1 (a) above.

TABLE 6-4. CHART OF SUGGESTED TESTS FOR LOCATING THE SPECIFIC TROUBLE (Continued)

LOCATION AND TYPE OF TROUBLE	SUGGESTED METHOD FOR LOCALIZING TROUBLE
<p>2. MODULATION CRYSTAL VOLTMETER INOPERATIVE.</p>	<p>a. The modulation crystal voltmeter (CR101 and CR102) rectifies the modulation signal which is obtained from the output of V107 and read on the lower scale of the meter (M101) when S102 is in the MOD position. If it is determined that this circuit is defective, replace CR101 and CR102.</p> <p style="text-align: center;">Note</p> <p>No zero set is necessary since germanium diodes do not have contact potential.</p> <p>b. If replacing CR101 and CR102 does not remedy the trouble, make continuity checks throughout the circuit.</p>
<p>3. BUFFER AND OUTPUT AMPLIFIER STAGES INOPERATIVE (V102, V103).</p>	<p>a. If preliminary tests have indicated that the buffer and output amplifier stages are inoperative, and proceed with the following tests.</p> <p>b. Test DC voltages with the tubes (V102 and V103) in their respective sockets; M101 set for "10" and carrier frequency set to 100 kc.</p> <p style="margin-left: 20px;">V102</p> <p style="margin-left: 40px;">Heater - 6.3v AC Plate Voltage - +215v DC Cathode Voltage - +2v DC Control Grid Voltage - 0 Screen Grid Voltage - +150v DC Suppressor Grid Voltage - 0</p> <p style="margin-left: 20px;">V103</p> <p style="margin-left: 40px;">Heater - 6.3v AC Plate Voltage - +220v DC Cathode Voltage - +5.2v DC Control Grid Voltage - 0 Screen Grid Voltage - +150v DC Suppressor Grid Voltage - 0</p> <p>DC measurements made from socket terminals to chassis with a 20,000 ohms per volt voltmeter.</p> <p>c. If the voltages are correct, but the buffer-output amplifiers are still inoperative, make a circuit continuity test with an ohmmeter until the defect is located.</p> <p style="text-align: center;">Note</p> <p>Check the tubes with a tube checker even though voltage checks are correct. Change in tube characteristic (e.g. transconductance etc.) may not be shown in voltage checks but may actually be the source of trouble.</p>
<p>4. CARRIER OSCILLATOR (V101).</p> <p>a. INOPERATIVE.</p>	<p>(1) If preliminary tests have indicated that the carrier oscillator is inoperative in all ranges, remove the signal generator from its cabinet and proceed with the following tests:</p> <p style="margin-left: 20px;">(a) Set the POWER switch (S103) in ON position and the frequency to 100 kc with the carrier oscillator tube (V101) in its socket, and test the tube voltages.</p> <p>Heater Voltage: 6.3v AC Plate Voltage: Varies between 0 and 150v DC depending on setting of carrier control (R173). (Checking this may or may not cause circuit to stop oscillating.) Grid Voltage: 0 to -0.5v DC (Varies with rotation of carrier control (R173).</p>

TABLE 6-4. CHART OF SUGGESTED TESTS FOR LOCATING THE SPECIFIC TROUBLE (Continued)

LOCATION AND TYPE OF TROUBLE	SUGGESTED METHOD FOR LOCALIZING TROUBLE																											
	Cathode Voltage: Varies between 0 and 10v DC. (b) Turn the POWER switch (S103) to OFF position and make the following resistance checks from grid to ground and grid to cathode, setting the frequency band switch knob (E119) to each corresponding position:																											
	<table border="1"> <thead> <tr> <th data-bbox="487 478 803 542">BAND</th> <th data-bbox="803 478 1096 542">RESISTANCE (grid to ground)</th> <th data-bbox="1096 478 1347 542">RESISTANCE (grid to cathode)</th> </tr> </thead> <tbody> <tr> <td data-bbox="487 542 803 574">A</td> <td data-bbox="803 542 1096 574">220K</td> <td data-bbox="1096 542 1347 574">267K</td> </tr> <tr> <td data-bbox="487 574 803 606">B</td> <td data-bbox="803 574 1096 606">150K</td> <td data-bbox="1096 574 1347 606">172K</td> </tr> <tr> <td data-bbox="487 606 803 638">C</td> <td data-bbox="803 606 1096 638">33K</td> <td data-bbox="1096 606 1347 638">51K</td> </tr> <tr> <td data-bbox="487 638 803 670">D</td> <td data-bbox="803 638 1096 670">10K</td> <td data-bbox="1096 638 1347 670">16.8K</td> </tr> <tr> <td data-bbox="487 670 803 702">E</td> <td data-bbox="803 670 1096 702">2.2K</td> <td data-bbox="1096 670 1347 702">4.4K</td> </tr> <tr> <td data-bbox="487 702 803 734">F</td> <td data-bbox="803 702 1096 734">22,000 ohms</td> <td data-bbox="1096 702 1347 734">22,000 ohms</td> </tr> <tr> <td data-bbox="487 734 803 766">G</td> <td data-bbox="803 734 1096 766">10,000 ohms</td> <td data-bbox="1096 734 1347 766">10,000 ohms</td> </tr> <tr> <td data-bbox="487 766 803 798">H</td> <td data-bbox="803 766 1096 798">4,700 ohms</td> <td data-bbox="1096 766 1347 798">4,700 ohms</td> </tr> </tbody> </table>	BAND	RESISTANCE (grid to ground)	RESISTANCE (grid to cathode)	A	220K	267K	B	150K	172K	C	33K	51K	D	10K	16.8K	E	2.2K	4.4K	F	22,000 ohms	22,000 ohms	G	10,000 ohms	10,000 ohms	H	4,700 ohms	4,700 ohms
	BAND	RESISTANCE (grid to ground)	RESISTANCE (grid to cathode)																									
	A	220K	267K																									
B	150K	172K																										
C	33K	51K																										
D	10K	16.8K																										
E	2.2K	4.4K																										
F	22,000 ohms	22,000 ohms																										
G	10,000 ohms	10,000 ohms																										
H	4,700 ohms	4,700 ohms																										
(c) If the ohmmeter reads "open" in any position of the frequency band switch knob (E119), either the corresponding coil, grid resistor, or cathode resistor is open. (d) If all voltage and continuity checks are correct, replace the tube and check results.																												
b. ERRATIC PERFORMANCE.	(1) Erratic performance of the carrier oscillator in a given band position is often difficult to trace. As a remedy, the following may be tried: (a) Substitute a new tube. <p style="text-align: center;">Note</p> DO NOT DISTURB ADJUSTMENTS UNTIL POSITIVE TUBE IS AT FAULT. (b) Check the frequency band turret contacts. (c) Check for a dirty or a faulty carrier control (R173). (d) Make visual inspection of main tuning capacitor (C123) for dirt, bent plates, etc. (2) Make visual inspection of the oscillator coil for the range in question.																											
c. EXCESSIVE VOLTAGE NEEDED ON CARRIER CONTROL (R173).	(1) Often defects in the resonant system (oscillator coils, capacitors, and grid resistors) can be suspected if a greater than normal amount of plate voltage is necessary in order to develop the required voltage output. (2) Check normal voltages between the slider (center lug) of the carrier (R173) and ground, in the following manner. (The carrier control should be set in the fully counterclockwise position): (a) POWER switch (S103) ON. (b) Carrier range switch (S101) to applicable range. (c) MOD, XTAL & METER SELECTOR switch (S102) at CW. (d) Main tuning dial (N102) set at beginning of all bands. (e) Oscillator plate voltages required for "10" meter reading. (1) Bands A through F — less than 100v DC. (2) Bands G and H — less than 150v DC.																											

TABLE 6-4. CHART OF SUGGESTED TESTS FOR LOCATING THE SPECIFIC TROUBLE (Continued)

LOCATION AND TYPE OF TROUBLE	SUGGESTED METHOD FOR LOCALIZING TROUBLE
<p>5. MODULATION OSCILLATOR.</p> <p>a. INOPERATIVE ON BOTH 400 AND 1000 CYCLES.</p> <p>b. INOPERATIVE ON ONLY ONE FREQUENCY (400 OR 1000 CYCLES).</p> <p>c. ERRATIC OPERATION OR PRESENCE OF AMPLITUDE DISTORTION.</p>	<p>(1) If it is indicated that the modulation oscillator is inoperative on both frequencies (400 and 1000 cycles), the probable defective part is some element common to both frequency position of the MGD-XTAL & METER SELECTOR switch (S102).</p> <p>(2) One possible trouble is too high a degree of degeneration. This degeneration is dependent upon the resistance ratio of R157 (degeneration control) and R159. Although the degeneration control (R157) is a locking type potentiometer, vibration may have changed its value. If its resistance is too small, the degeneration will be too great and oscillations will be inhibited. Sometimes increasing the resistance (R157) will assist the oscillator in breaking into oscillation. If this is the case, set this resistor at the point where oscillations just begin.</p> <p>(3) If a spare tube is available, it is sometimes most expedient to replace the old tube.</p> <p>(4) If replacing the tube does not solve the problem, continuity and voltage checks should be made. In making these voltage checks, refer to Table 6-5 TUBE OPERATING VOLTAGES AND CURRENTS.</p> <p>(1) If the modulation oscillator is inoperative on only one frequency, the solution is relatively simple.</p> <p>(2) The defective element is probably one of the bridge resistors (R152, R153, R154 and R155).</p> <p>(3) Make the necessary resistance checks.</p> <p>(1) If the locking device on the degeneration resistor (R157) is loosened, mechanical vibration may cause a variation of resistance and hence degeneration. This may result in erratic operation or amplitude distortion. Check this control and tighten the locknut.</p>
<p>6. STEP ATTENUATOR (AT101).</p> <p>Note: Use multimeter ME-25/U Series or equivalent for tests in Items a, b and c. below.</p> <p>a. NO OUTPUT ON ALL STEPS.</p>	<p>(1) If there is output from J101 but no output from J102 in all steps of AT101, the 500 ohms resistor (R130) may be burned out, or the coaxial cable of the attenuator may be open.</p> <p>(2) The following indirect check of R130 and the coaxial cable may be made from RF OUTPUT-X-200K- OPEN CIRCUIT jack J101 to ground; without removing the signal generator from its case.</p> <p>(a) Turn power switch S103 off.</p> <p>(b) Place the output/range switch S101 to X200K position.</p> <p>(c) Set the RF MULTIPLIER (AT101) to the X10K step.</p> <p>(d) Under the above conditions the normal resistance from J101 to ground is 655 ohms.</p> <p>(3) The resistance of the 500 ohm resistor R130 (see fig. 6-6) may be measured, without unsoldering, by placing the ohmmeter test leads directly across it.</p> <p>(4) Continuity of the coaxial cable leading to AT101 may be determined by disconnecting it at jack J103 and measuring the resistance from the center pin of the BNC plug (UG-88/U) to ground. The resistance should be 55.5 ohms.</p>

TABLE 6-4. CHART OF SUGGESTED TESTS FOR LOCATING THE SPECIFIC TROUBLE (Continued)

LOCATION AND TYPE OF TROUBLE	SUGGESTED METHOD FOR LOCALIZING TROUBLE
b. NO OUTPUT ON ONE OR MORE, BUT NOT ALL STEPS.	<p>(1) One of the step attenuator series resistors (R132, R134, R136, R138, R140) is burned out. This may be determined without removing the signal generator from its case as follows:</p> <p>(a) Place the output/range switch (S101) to X-MULT position.</p> <p>(b) Make sure POWER switch (S103) is turned off.</p> <p>(c) Make connection to RF OUTPUT X-MULT jack J102. Use a short length of coaxial cable and a BNC plug type UG-88/U for this connection.</p> <p>(d) If one of the series resistors R134, R136, R138 and R140 is open the reading obtained to ground on two successive positions will be 55 ohms instead of the normal 50 ohms. For example, if series resistor R138 is open; the readings obtained on steps X10 and X1 will be 55 ohms. If the series resistor R132 is open, the readings on X10K and X1K will be 61.8 and 55 ohms respectively.</p>
c. APPROXIMATELY 2:1 INSTEAD OF 10:1 ATTENUATION BETWEEN TWO SUCCESSIVE STEPS.	<p>(1) One of the step attenuator shunt resistors (R133, R135, R137 and R139) is probably burned out.</p> <p>(2) Check the resistance at J102 to ground, if one of the above shunt resistors is open a reading of 275 ohms to ground at any of the respective positions: X1K, X100, X10, X1 will indicate that defective resistor (See fig. 2-8).</p> <p>(3) If one of the shunt resistors R131 or R141 is open the readings obtained at the X10K or 0.1 positions, respectively, will be 550 ohms.</p>
d. REPLACING STEP ATTENUATOR RESISTORS.	<p>(1) Recalibrate step attenuator ratios for range in which resistor was replaced, using (10:1) Fixed Attenuator CN-224/URM-25D and a radio receiver such as Navy Model RBA series or equivalent. Follow the procedure outlined in Section 6, par. 17.</p> <div style="text-align: center; border: 1px dashed black; padding: 5px; width: fit-content; margin: 10px auto;"> CAUTION </div> <p>Resistance measurements at J102 should be made with a resistance bridge such as Resistance Bridge ZM-4/U, or equivalent, to avoid burning out one of the step attenuator resistors. If the electronics technician uses an ordinary ohmmeter, great care must be exercised to see that this ohmmeter does not place a current in excess of 20 milliamperes through the attenuator circuit while testing. Any repairs to the attenuator should be made by qualified technicians.</p>
7. POWER SUPPLY PP-977/URM-25D a. INOPERATIVE.	<p>(1) Check line fuses F101 and F102.</p> <p>(2) With an ohmmeter check interconnecting cables W102 and W103 for continuity.</p> <p>(3) Check power transformer (T201).</p> <p>(4) If no B+, check rectifier tube V201, filter choke L201 and series resistor R201.</p>
b. OVERHEATING.	<p>(1) Check for short circuited turns on T201.</p> <p>(2) Check for partial breakdown of C201, C202, and C203. It is sometimes best to replace one or all of these capacitors, if it is suspected that one of them is defective. A voltage or ohmmeter check will not always identify this trouble.</p>

TABLE 6-4. CHART OF SUGGESTED TESTS FOR LOCATING THE SPECIFIC TROUBLE (Continued)

LOCATION AND TYPE OF TROUBLE	SUGGESTED METHOD FOR LOCALIZING TROUBLE
c. LOSS OF REGULATION.	<p>(1) Check with a variac or variable voltage source. Change the line voltage from 103v to 126v AC. The + 150v DC output should not change. This does not apply to the unregulated + 220v DC supply.</p> <p>(2) Replace regulator tube (V108) if the B+ does not remain steady at 150v DC.</p>
8. HUM MODULATION.	<p>a. Listen for power line hum (impressed on carrier frequency) or check output on scope.</p> <p>b. Check for unshielded leads between signal generator and receiver. All leads between these units should be shielded.</p> <p>c. Check for mechanical vibrations of T201. Tightly secure the transformer mounting.</p> <p>d. Change the oscillator tube (V101).</p>
<p>9. ACCESSORY UNITS.</p> <p>a. IMPEDANCE ADAPTER MX-1487/URM-25D.</p> <p>b. ANTENNA SIMULATOR SM-35/URM-25.</p> <p>c. (5:1) FIXED ATTENUATOR CN-223/URM-25D.</p> <p>d. (10:1) FIXED ATTENUATOR CN-224/URM-25D.</p> <p>e. TEST LEAD CX-1363/U.</p>	<p>If it is suspected that any one of these accessory units is defective, a simple continuity check will readily indicate the source of trouble.</p> <div style="text-align: center; border: 1px dashed black; padding: 5px; width: fit-content; margin: 10px auto;"> <p>CAUTION</p> </div> <p>When making a resistance check on the Impedance Adapter MX-1487/URM-25D be sure the lowest ohmmeter resistance range is used. Ohmmeters with internal batteries larger than 1.5v may burn out the resistor in the impedance adapter. Where greater accuracy is desired, resistance measurements should be made with the Resistance Bridge ZM-4/U or equivalent.</p>
10. OUTPUT CABLES.	Check leakage resistance with a megger (high resistance ohmmeter).
11. CRYSTAL CALIBRATOR (V105).	<p>If the check in Table 6-3 under CRYSTAL CALIBRATOR indicates that this unit is defective, the following tests should be made to localize the trouble.</p> <div style="text-align: center; margin: 10px 0;"> <p>Note</p> </div> <p>The output beat of the crystal calibrator is amplified by both sections of the beat note amplifier (V106) and the cathode follower (V107). Make sure that this stage is functioning (Table 6-3, under MODULATION OSCILLATOR) before deciding that the V105 circuit is defective.</p> <p>(1) Replace crystal (Y101), then tube V105 if available. These parts are the most common source of trouble in the crystal calibrator.</p> <p>(2) If a substitute tube and crystal are not available, check V105 in a tube checker.</p> <p>(3) Make circuit continuity and voltage tests. Figure 6-15 indicates the normal socket to ground voltages and resistances for V105. The following readings from socket pins to ground indicate that either the tube V105 or crystal Y101 is defective. Measurements should be made with a 20,000 ohm/DC and 1000 ohm/VAC meter.</p>

TABLE 6-4. CHART OF SUGGESTED TESTS FOR LOCATING THE SPECIFIC TROUBLE (Continued)

LOCATION AND TYPE OF TROUBLE	SUGGESTED METHOD FOR LOCALIZING TROUBLE			
	PIN	CORRECT	CRYSTAL (Y101) DEFECTIVE	TUBE (V105) DEFECTIVE (NOT CONDUCTING)
b. FREQUENCY CALIBRATION.	1	-8v DC	-0.2v Dc	0
	2	approx. 0.1	approx. 0.1	0
	3	0		0
	4	6.3v AC	6.3v AC	0 if filaments are open 6.3v AC if filaments are not open.
	5	125v DC	8v DC	220v DC
	6	95v DC	45v DC	220v DC
	7	0.1v DC	0.25v DC	0
<p>(1) Provision is made for calibrating the 1 mc frequency of the crystal calibrator, if it is suspected that its accuracy has fallen off in excess of $\pm 0.05\%$. The calibration should be accomplished in the following manner:</p> <p>(a) Remove RF Signal Generator SG-85/URM-25D. (See par. 8a).</p> <p>(b) Connect the signal generator unit to Power Supply PP-977/URM-25D.</p> <p>(c) Tune a receiver, such as Navy Model RBC series to the 5 mc signal of Navy station WWV.</p> <p>(d) Turn the signal generator on and CARRIER CONTROL fully counter-clockwise.</p> <p>(e) Turn MOD-XTAL & METER SELECTOR switch (S102) to XTAL position. Connect a lead from the X-200K RF OUTPUT jack J101 to the antenna input on the RBC. Sufficient crystal output will be available at J101 to drive the receiver.</p> <p>(f) With the receiver tuned to WWV, adjust crystal frequency adjusting capacitor (C158) (figure 6-9) for zero beat (fifth harmonic of 1 mc crystal) against WWV. A set of earphones or speaker can be used for monitoring this beat.</p>				

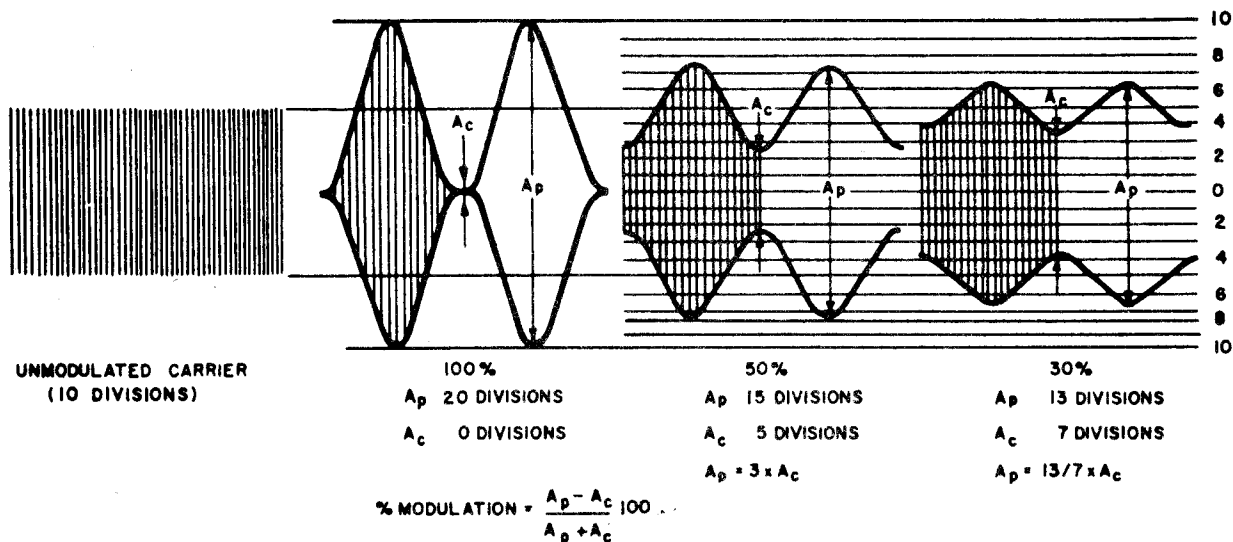
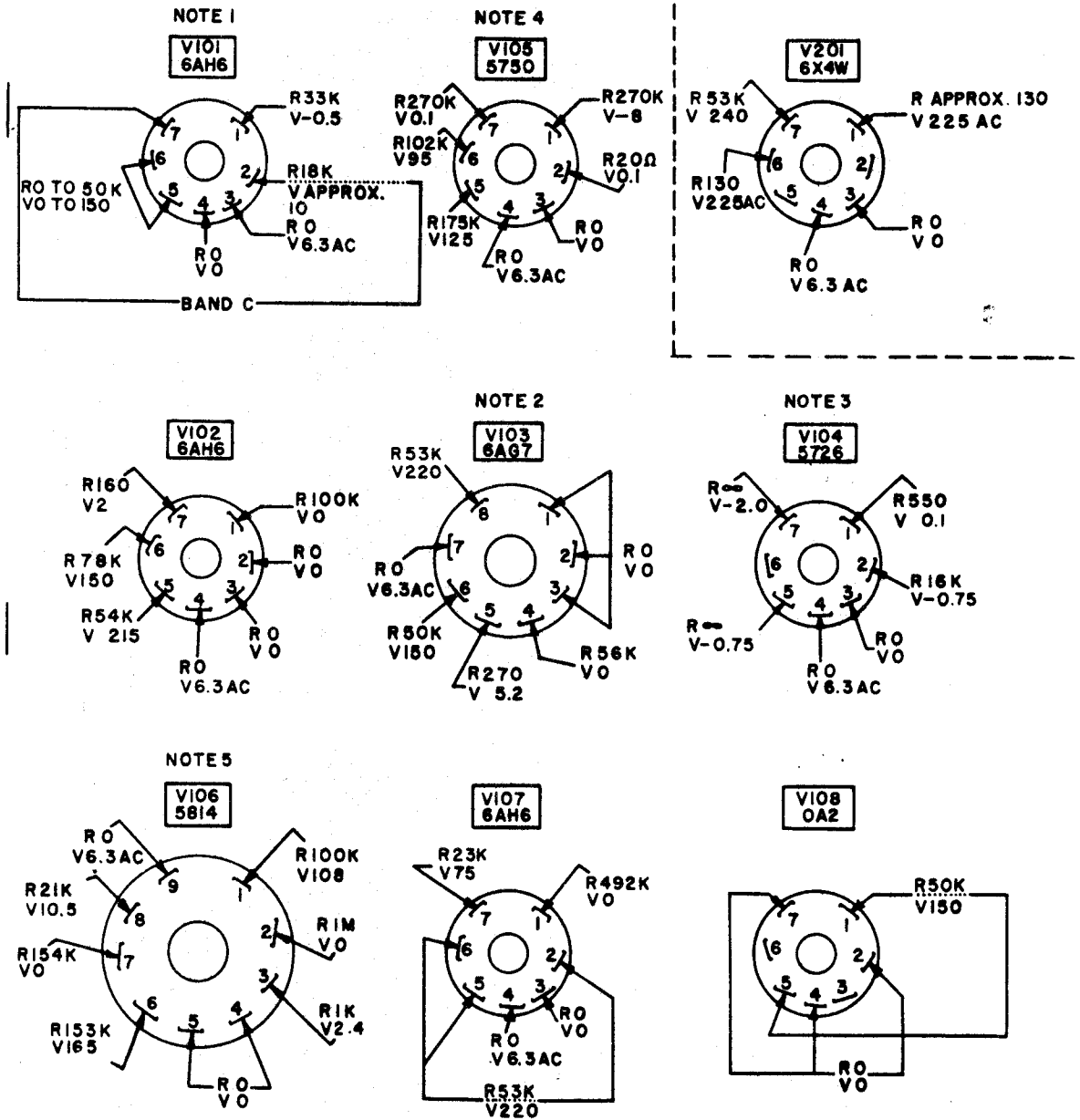

Figure 6-14. Percentage Modulation Chart



NOTES:

1. BAND "C" OPERATION (.95 - 300 KC)
2. S102 SWITCH IN CRYSTAL OR CW POSITION
3. CAUTION: DO NOT MEASURE RESISTANCE FROM PINS 5 OR 7 TO GROUND WITH S102 IN CRYSTAL OR CW POSITION, HOWEVER, VOLTAGE READINGS WERE TAKEN WITH S102 IN CW POSITION, M101 SET TO 10 MV, AND FREQUENCY SET TO 10 KC
4. S102 IN CRYSTAL POSITION
5. S102 IN 1000 CYCLE POSITION

RESISTANCE AND VOLTAGE MEASUREMENTS MADE BETWEEN TEST POINT AND GROUND.
ALL DC READINGS TAKEN WITH A 20,000 OHMS/VOLT METER.
ALL AC READINGS TAKEN WITH A 1,000 OHMS/VOLT METER.

Figure 6-15. Signal Generator Voltage and Resistance Chart

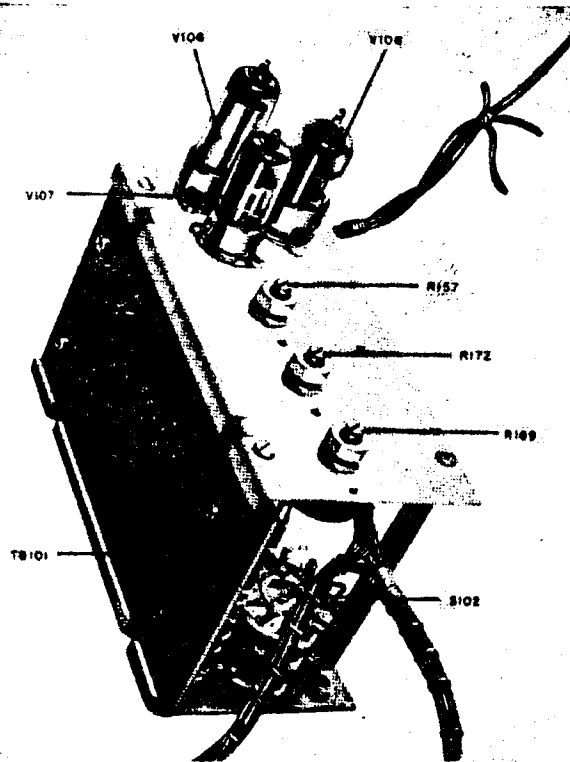

Figure 6-16. Rear View of Audio and Metering Unit

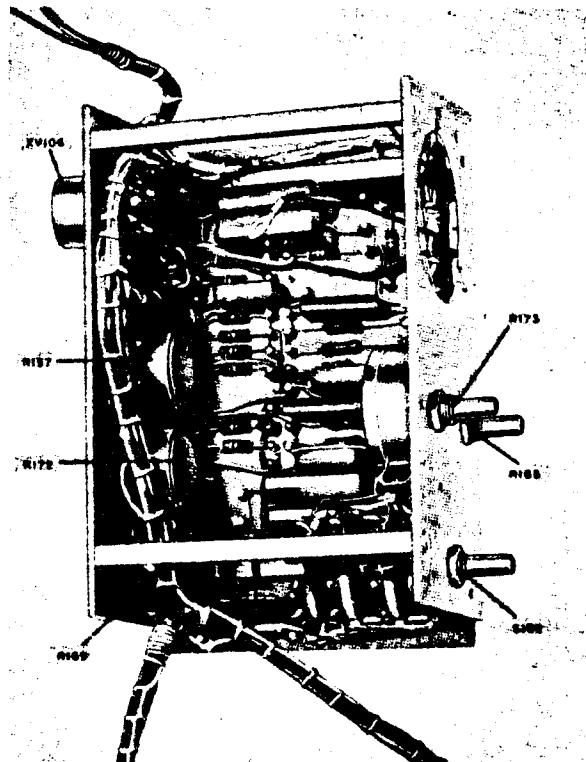

Figure 6-17. Interior View of Audio and Metering Unit Showing Terminal Board and Position of Resistors

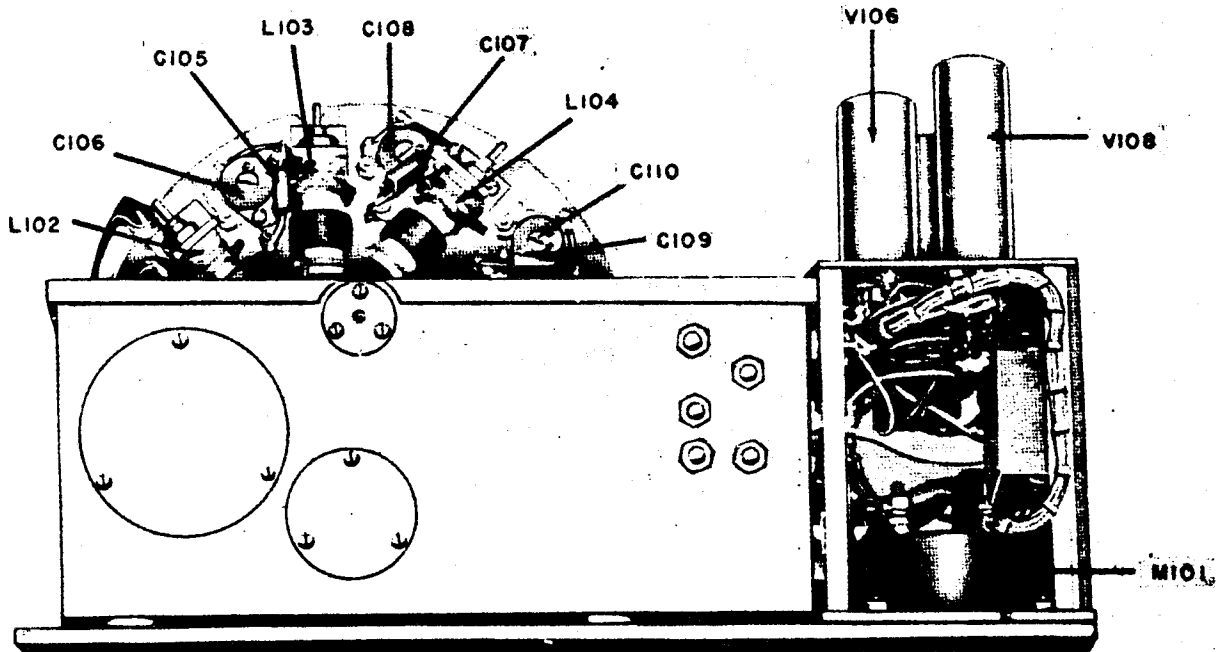

Figure 6-18. Top View of Signal Generator SG-85/URM-25D

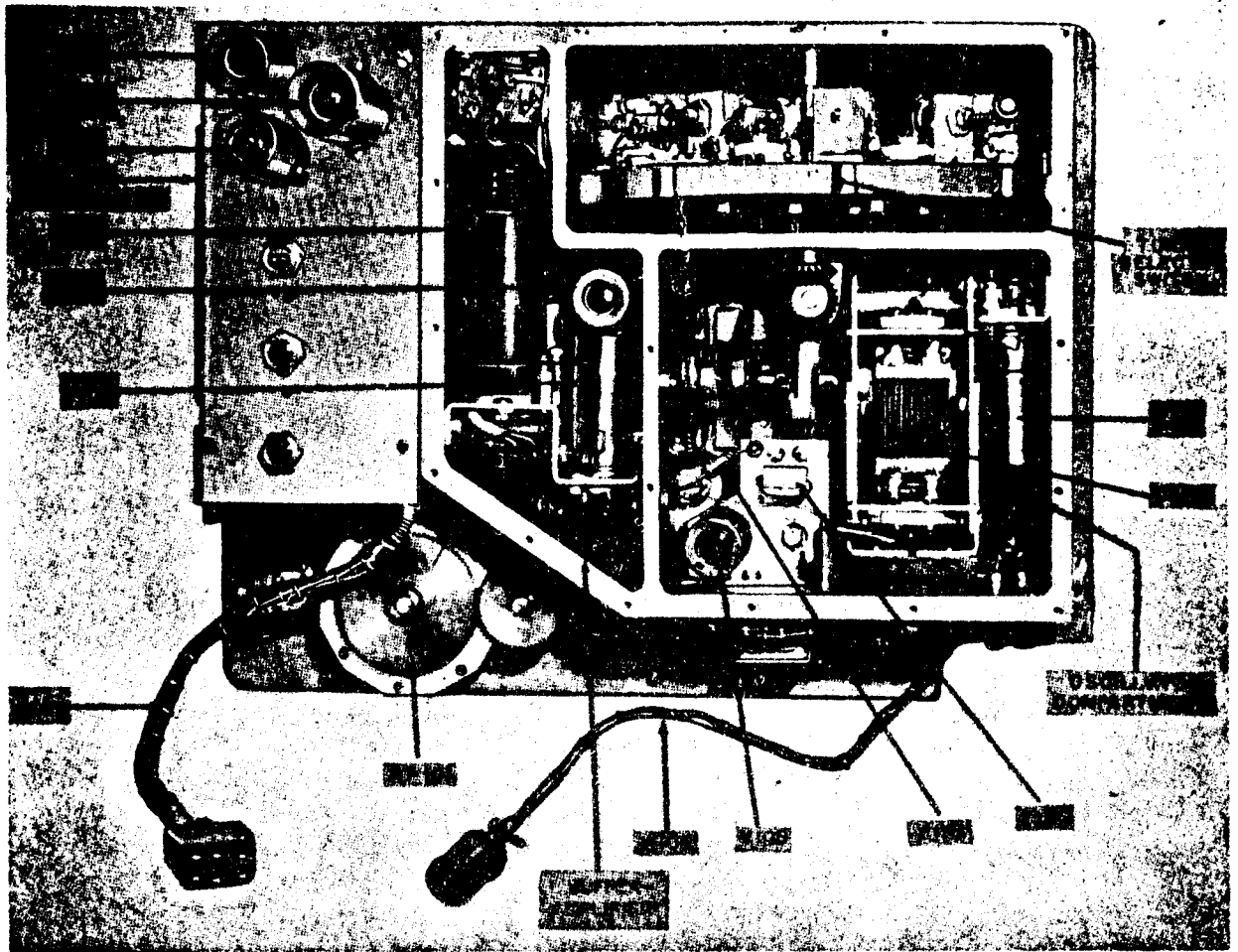

Figure 6-19. Rear View of Signal Generator SG-85/URM-25D

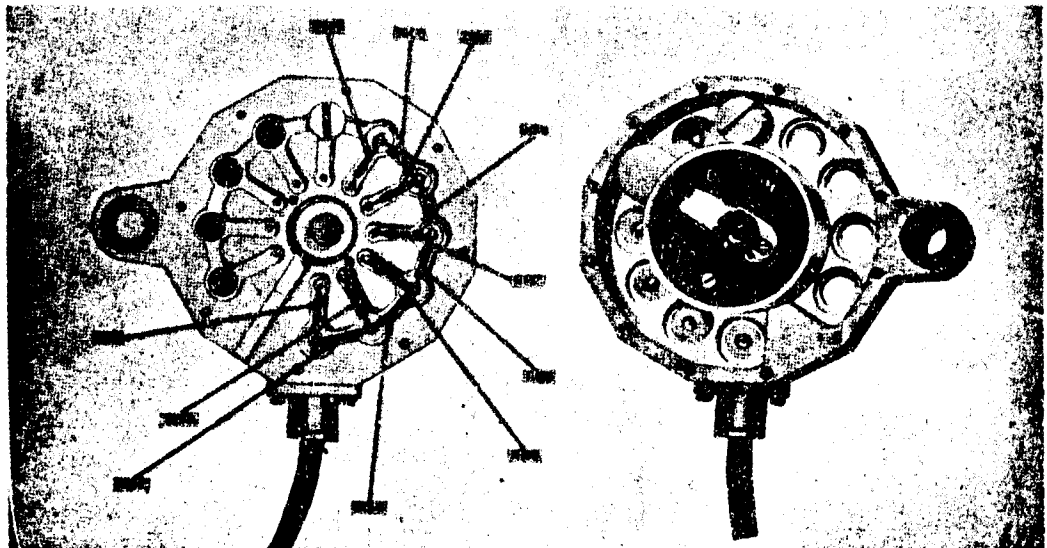

Figure 6-20. Top and Bottom Interior Views of Step Attenuator AT101

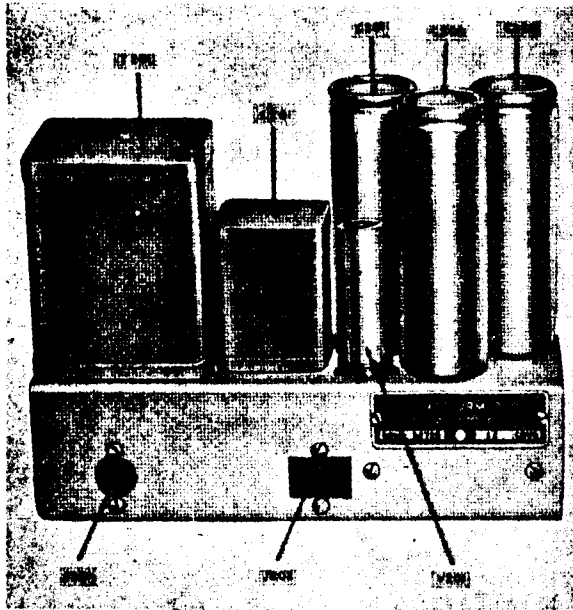

Figure 6-21. Top and Bottom Views of the Power Supply PP-977/URM-25D

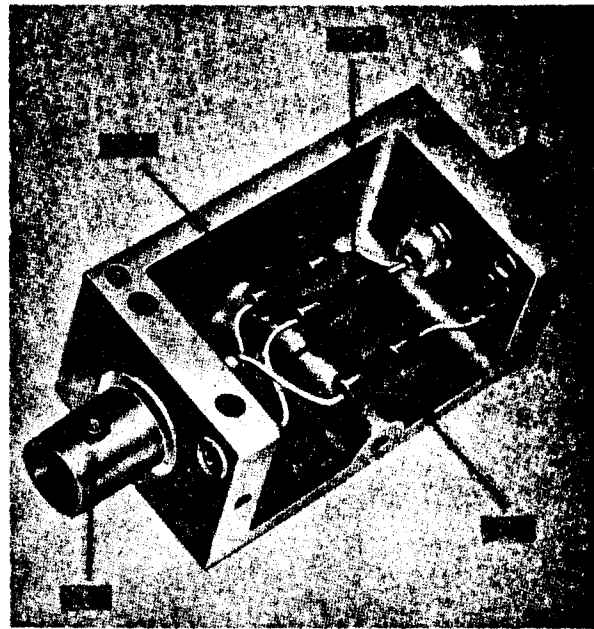

Figure 6-22. Interior View of (5:1) Fixed Attenuator CN-223/URM-25D

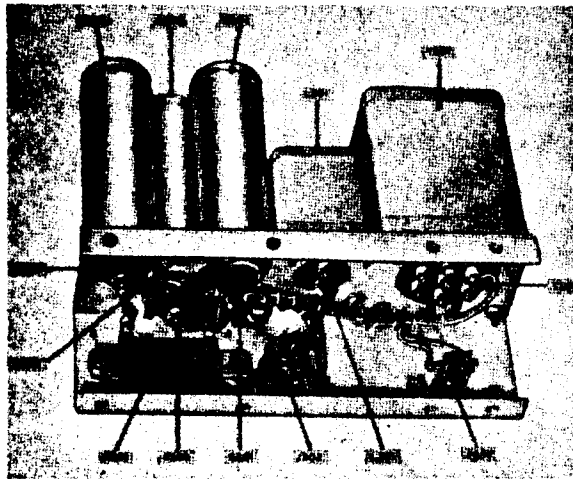
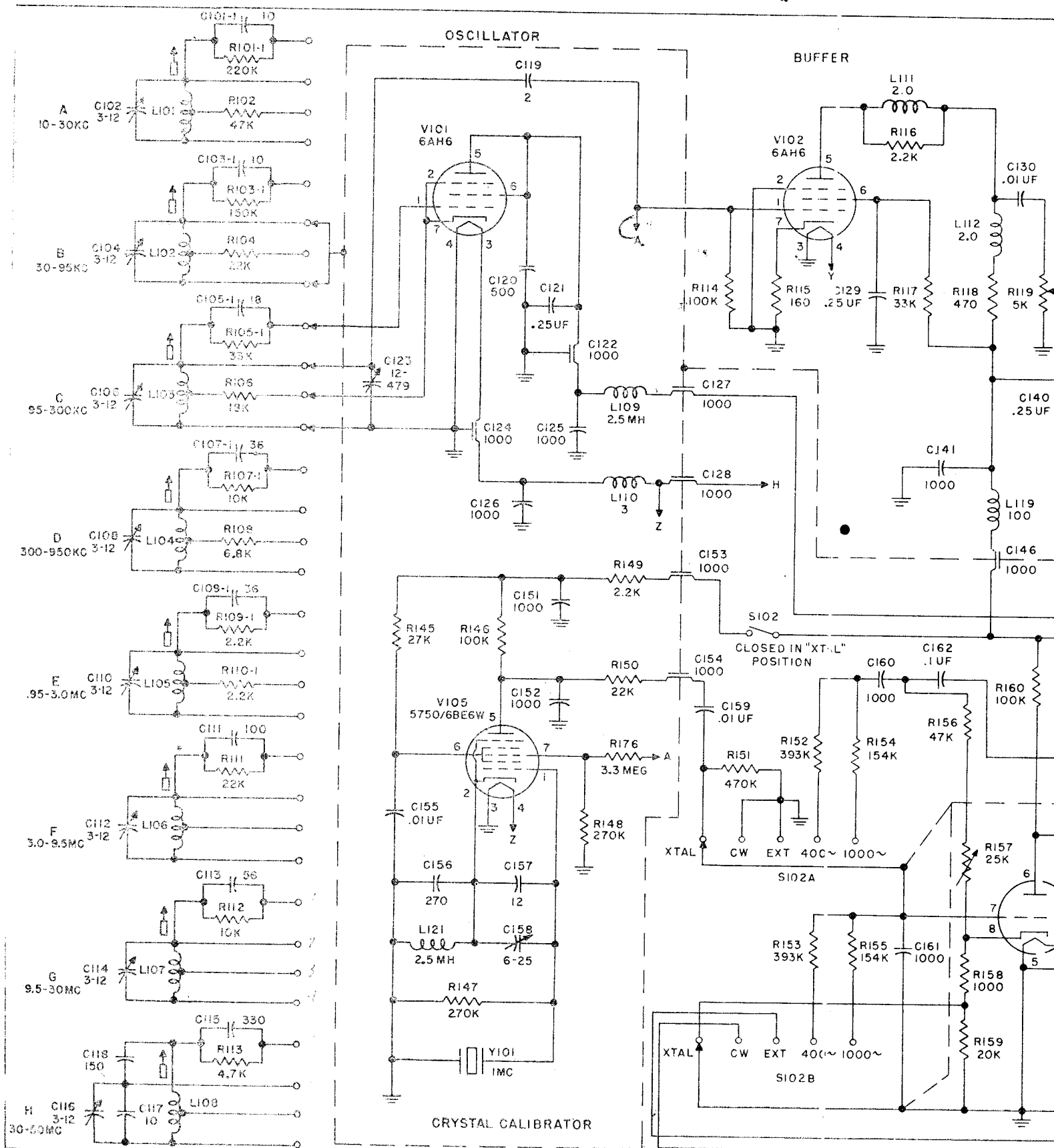
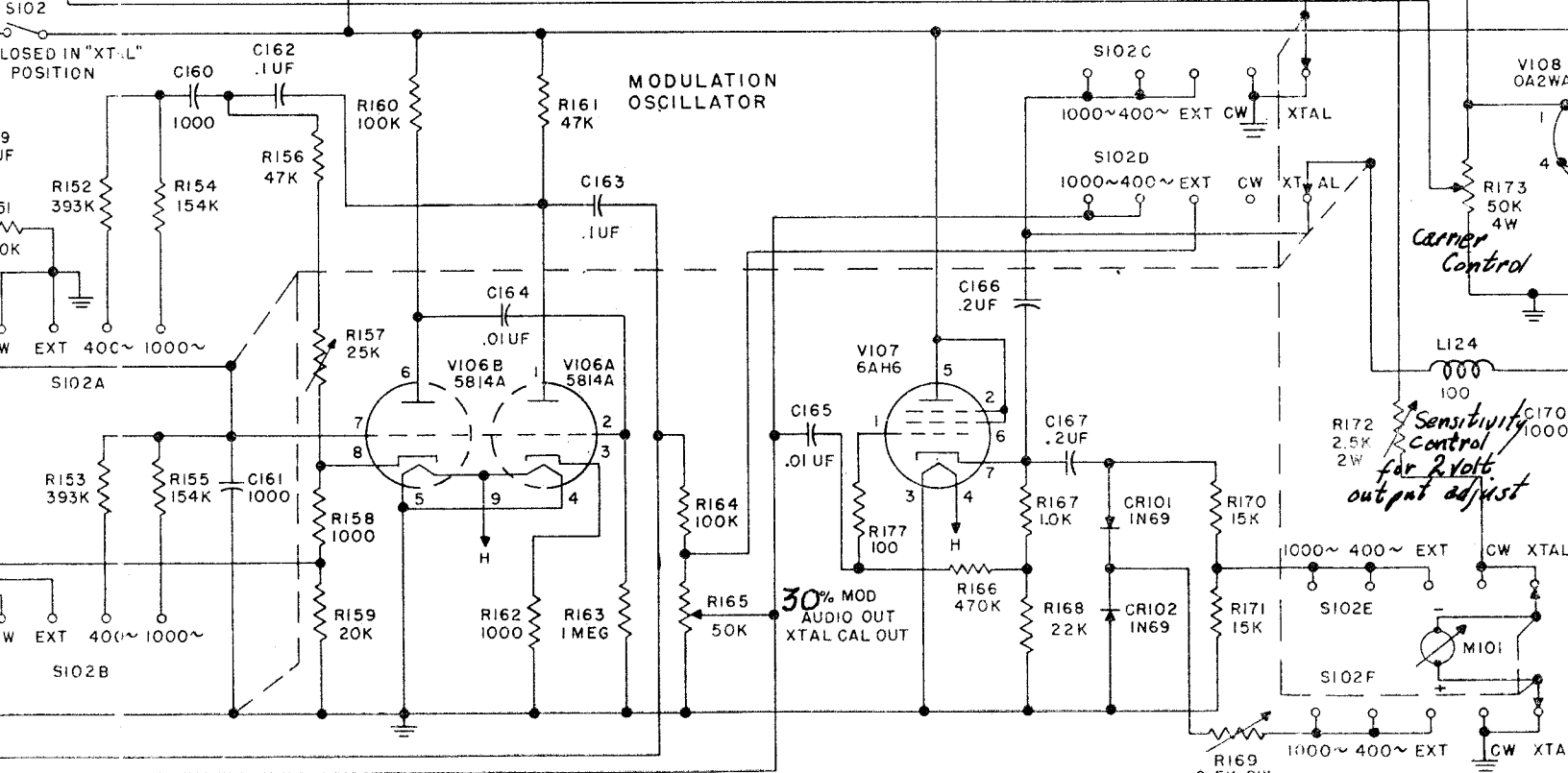
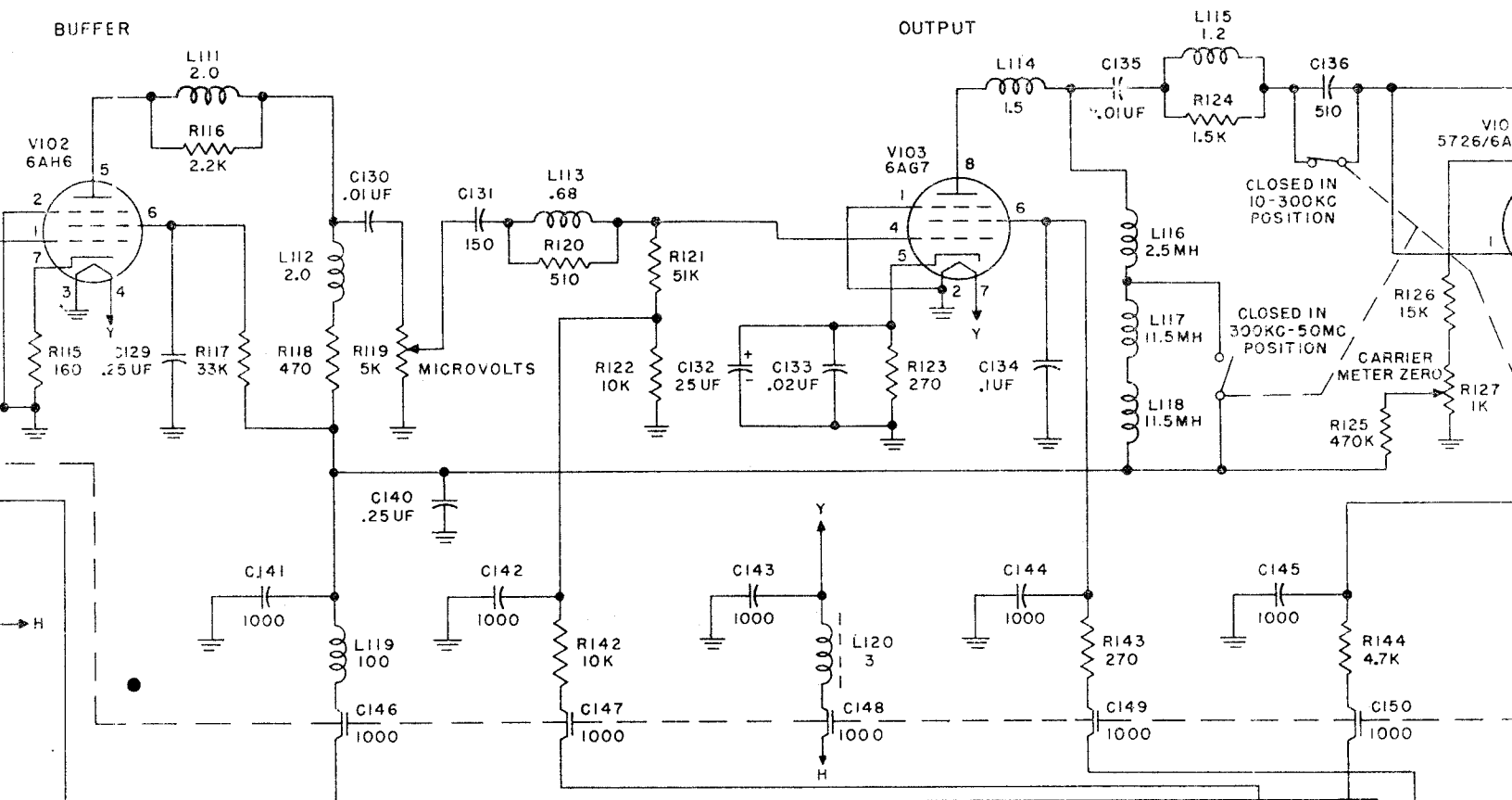

Figure 6-23. Interior View of Antenna Simulator SM-35/URM-25



BUFFER

OUTPUT



Sensitivity Control for 2 volt output adjust

30%

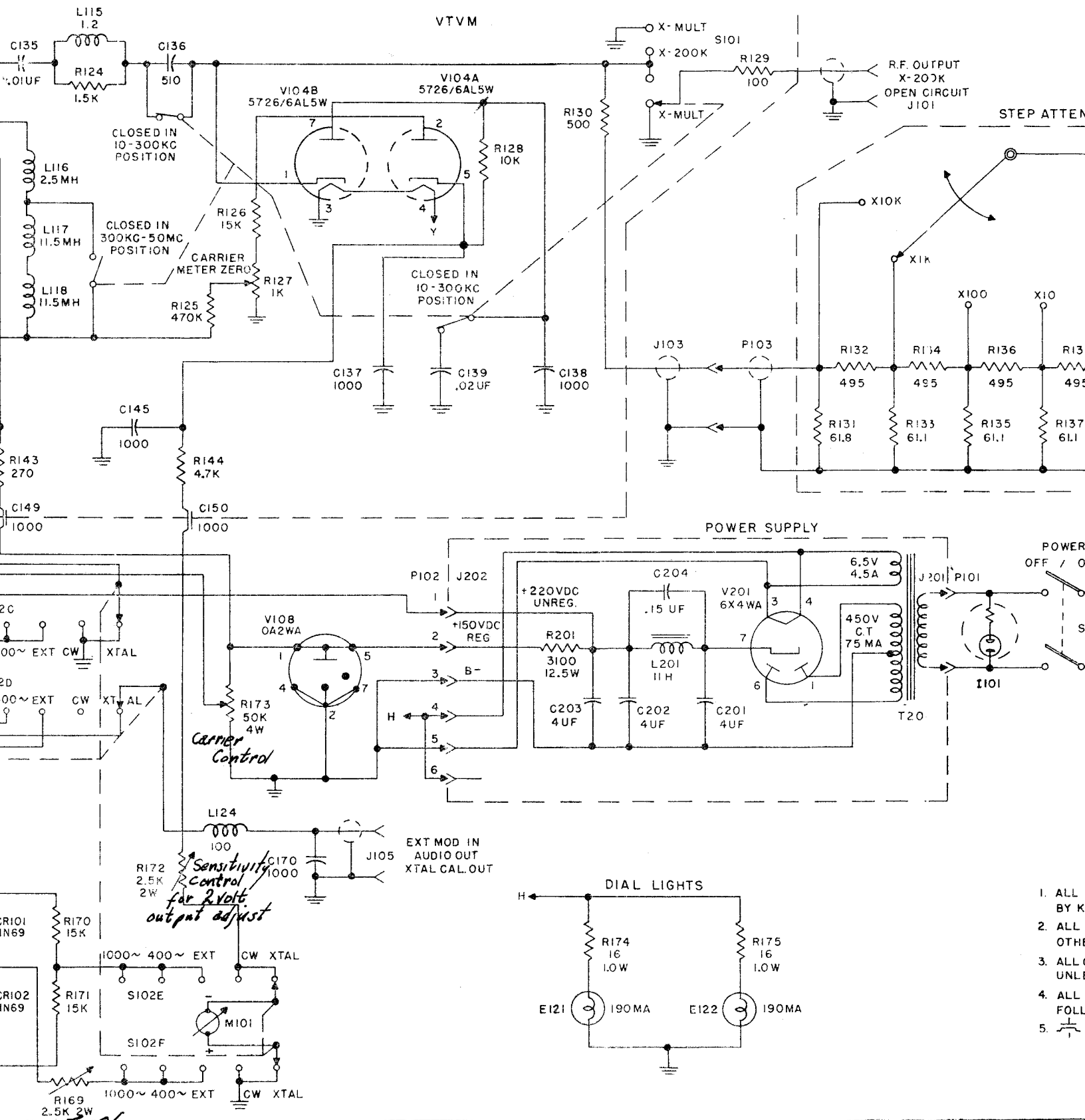

1. ALL BY K
2. ALL OTHER
3. ALL UNL
4. ALL FOLL
- 5.

50%

Figure 6
CHANGE 2

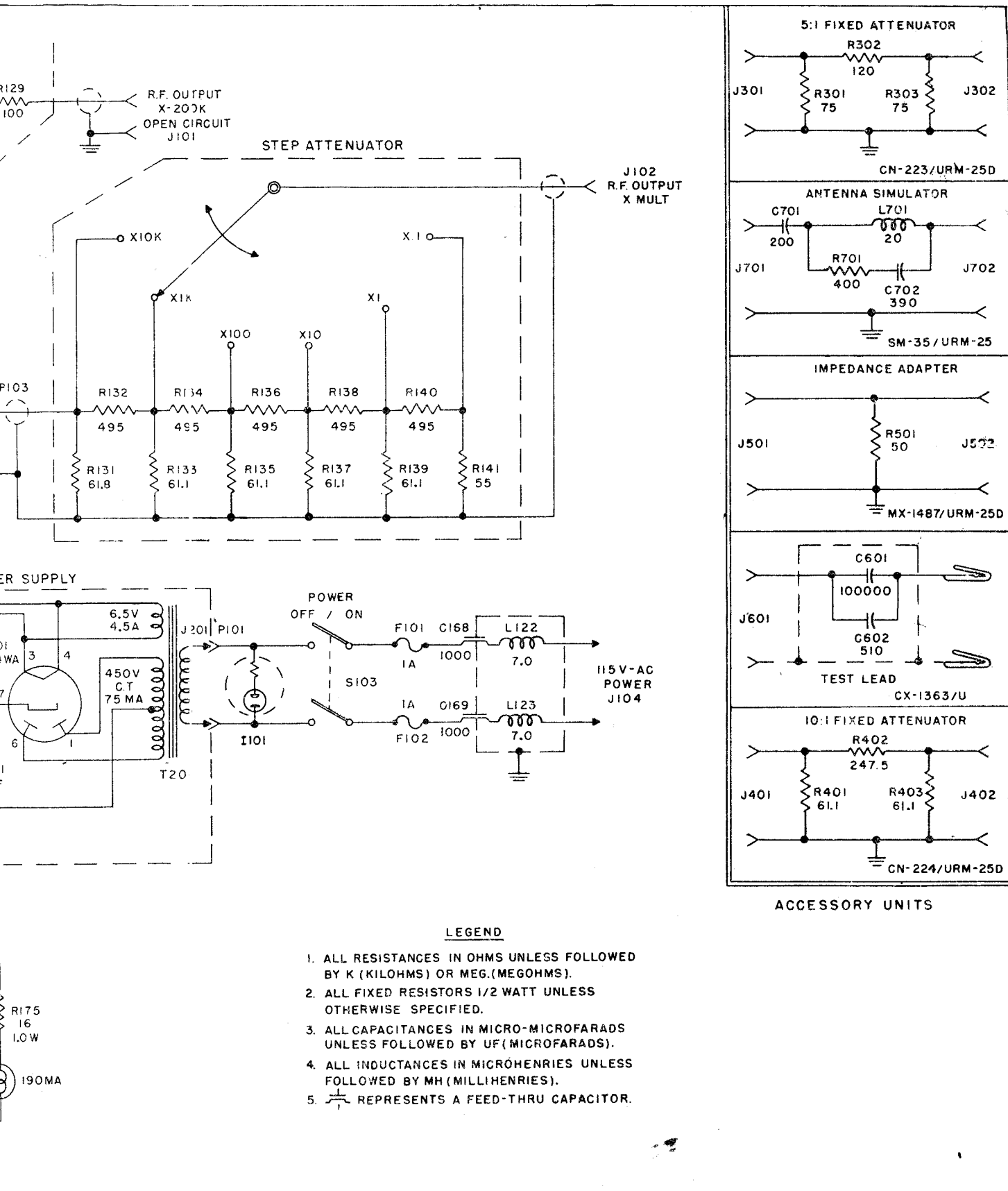

LEGEND

1. ALL RESISTANCES IN OHMS UNLESS FOLLOWED BY K (KILOHMS) OR MEG. (MEGOHMS).
2. ALL FIXED RESISTORS 1/2 WATT UNLESS OTHERWISE SPECIFIED.
3. ALL CAPACITANCES IN MICRO-MICROFARADS UNLESS FOLLOWED BY UF (MICROFARADS).
4. ALL INDUCTANCES IN MICROHENRIES UNLESS FOLLOWED BY MH (MILLIHENRIES).
5.  REPRESENTS A FEED-THRU CAPACITOR.

Figure 6-24. RF Signal Generator Set AN/URM-25D, Overall Schematic Diagram

CHANGE 2

6-25, 6-26

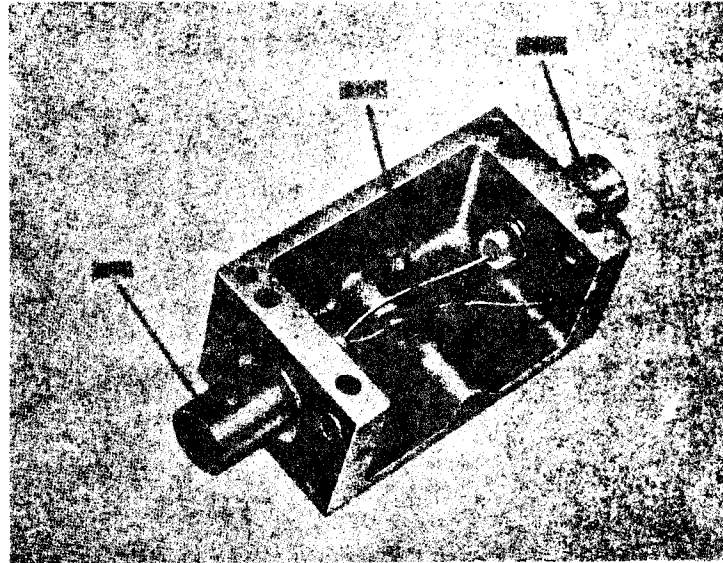

Figure 6-25. Interior View of
Impedance Adapter MX-1487/URM-25D

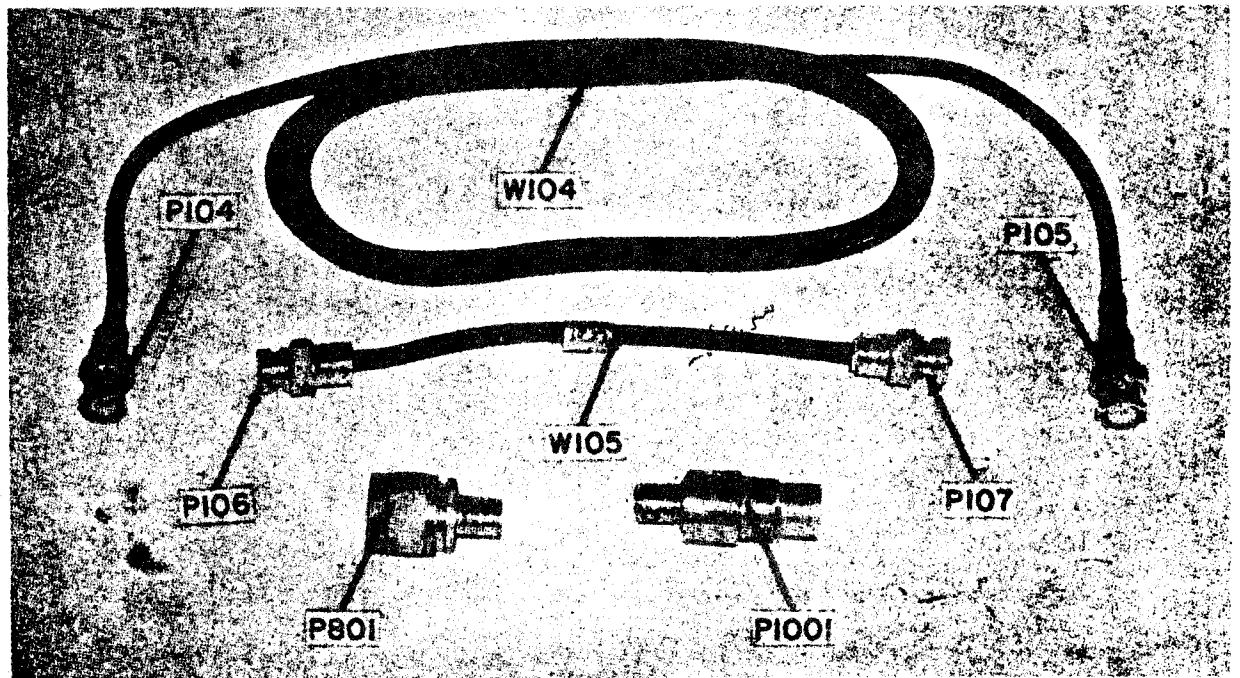

Figure 6-26. RF Connectors and Cable Assemblies

TABLE 6-5. TUBE OPERATING VOLTAGES AND CURRENTS

SYMBOL NUMBER	TUBE TYPE	FUNCTION	PLATE P (E)	PLATE (MA)	SCREEN (E)	SCREEN (MA)	SUPPRESSOR (E)	CATHODE (E)	GRID (E)	HEATER VAC
V101	6AH6	Carrier Oscillator	0 to 150	0 to 10	Connected to Plate	0	Approx. ¹ 10	Approx. -0.5 ¹	6.3
V102	6AH6	Buffer Amplifier	215	10	150	2.1	0	2.0	-0.	6.3
V103	6AG7	Output Amplifier	220	17	150	2	0	5.2	0	6.3
V104A	5726/6AL5W/ 6097	VTVM Compensator	Pin 2 ² 0 to -1.0	0 to 0.01 ²	Pin 1 ² 0 to 0.2	6.3
V104B	5726/6AL5W/ 6097	VTVM Rectifier	Pin 7 ² 0 to -2.0	0 to 0.2	Pin 5 ² 0 to -1.0	6.3
V105	5750/6BE6W	Crystal Calibrator	1253	0.5 ³	953	3.0 ³	0.1 ³	.1 ³	-8 ³	6.3
V106A	5814A	Modulation Oscillator	Pin 1 ⁴ 108	2.4 ⁴	Pin 3 ⁴ 2.4	Pin 2 0	6.3
V106B	5814A	Modulation Oscillator	Pin 6 ⁴ 163	0.55 ⁴	Pin 8 ⁴ 10.5	Pin 7 0	6.3
V107	6AH6	Modulation Amplifier	220	3.0	220	0.3	220	75	0	6.3
V108	0A2WA	B+ Regulator	150	20 to 10	0
V201	6X4WA	Rectifier	225V AC	240	6.3

NOTES: All measurements made with a 20,000 ohm/volt DC and 1000 ohm/volt AC meter with the Signal Generator set in the following operating condition:

- (1) Band "C" operation.
- (2) S102 switch in "CW" position.
- (3) S102 switch in "Crystal" position.
- (4) S102 switch in 400 or 1000 cycle position.

TABLE 6-6. RATED TUBE CHARACTERISTICS

TUBE TYPE	FILAMENT VOLTAGE (V)	FILAMENT CURRENT (A)	PLATE VOLTAGE (V)	GRID BIAS (V)	SCREEN VOLTAGE (V)	PLATE CURRENT (MA)	SCREEN CURRENT (MA)	A-C PLATE RESISTANCE (OHMS)	VOLTAGE AMPLIFICATION (MU)	TRANSCONDUCTANCE (MICROMHOS)		EMISSION	
										NORMAL	MINIMUM	IS(MA)	TEST VOLT
OA2WA	150	5-30
6AG7	6.3	0.65	375	-75	250	30	9.0
6AH6	6.3	0.45	300	160	150	10	2.50	500,000	9000
6X4WA	6.3	0.60	325	210
5726/6AL5W/6097	6.3	0.30	117
5750/6BE6W	6.3	0.30	250	-1.5	100	2.6	7.5	1 Meg.	Conversion 475
5814A	12.6	.175	250	-8.5	26	1800	43	24000

RATED ZENER DIODE CHARACTERISTICS

	ZENER VOLTAGE V_z @ I_{ZT} (OHMS)	TEST CURRENT I_{ZT} (MA)	MAX ZENER IMPEDANCE Z_{ZT} @ I_{ZT} (OHMS)	MAX DC ZENER CURRENT I_{ZM} (MA)	MAX FORWARD VOLTAGE V_F @ $I_F = 2A$
1N2970B	6.8 ± 5%	370	1.2	1.320	1.3

RATED GERMANIUM CRYSTAL DIODE CHARACTERISTICS

TYPE	MAX. INVERSE VOLTS	PEAK RECTIFIED MA.	MAX. SURGE MA.	MAX REVERSE μ -Amp.	MAX AVERAGE MA.
1N69A	60	150	500	800 @ 50V	40
1N277	125	270	400	250 @ 50V	50

TABLE 6-7. WINDING DATA

DESIGNATION SYMBOL	TRAD. MFG. & ENG. PART NO.	DIAGRAM	WINDING	WIRE SIZE	TURNS	DC RESISTANCE IN OHMS	REMARKS
L101	107-B-632		Universal wound 2 pie	#40 Single Strand Enameled	4800 Tap at 1700 turns	1000 ± 10%	Inductance: 511.5 mh; Impregnated
L102	107-B-633		Universal wound 1 pie	#38 Single Strand Enameled	1800 Tap at 780 turns	170 ± 10%	Inductance: 56.2 mh; Impregnated
L103	107-B-634		Universal wound 1 pie	#36 Double Strand Enameled	560 Tap at 240 turns	52 ± 10%	Inductance: 5.7 mh; Impregnated
L104	107-B-635		Universal wound 1 pie	#36 Double Strand Enameled	180 Tap at 85 turns	12.2 ± 10%	Inductance: 0.574 mh; Impregnated

TABLE 6-7. WINDING DATA (Continued)

DESIGNATION SYMBOL	TRAD MFG. & ENG. PART NO.	DIAGRAM	WINDING	WIRE SIZE	TURNS	DC RESISTANCE IN OHMS	REMARKS
L105	107-B-636		Universal wound 1 pic	#36 Double Strand Enameled	52 Tap at 24 turns	$3.4 \pm 10\%$	Inductance: 57.1 uh; Impregnated
L106	107-B-637		Single Layer	#30 Enameled	20 Tap at 10 turns	$0.03 \pm 10\%$	Inductance: 5.79 uh; Impregnated
L107	107-B-638		Single Layer	1/16 wide 0.005 THK Copper Silver Plated	6 Tap at 3 turns	$0.04 \pm 20\%$	Inductance: 0.579 uh; Impregnated
L108	107-B-639		Single Layer	3/32 wide 0.005 THK Copper Silver Plated	4 Tap at 2 turns	$0.014 \pm 20\%$	Inductance: 0.237 uh; Impregnated

ORIGINAL

TABLE 6-7. WINDING DATA (Continued)

DESIGNATION SYMBOL	TRAD MFG. & ENG. PART NO.	DIAGRAM	WINDING	WIRE SIZE	TURNS	DC RESISTANCE IN OHMS	REMARKS
L114	International Resistance Co. Type CLA		Single Layer	—	—	1.2 ± 20%	Inductance: 1.5 uh ± 10%
L115	International Resistance Co. Type CLA		Single Layer	—	—	0.85 ± 20%	Inductance: 1.2 uh ± 10%
L117 L118	107-B-642		Universal wound 3 pie	#36 Single Strand Enameled	900	46 ± 10%	Inductance: 11.5 mh ± 5% Impregnated
L119 L124	107-B-644		Universal wound 2 pie	#38 Single Strand Enameled	180	8.7 ± 10%	Inductance: 100 uh ± 10% Impregnated

TABLE 6-7. WINDING DATA (Continued)

DESIGN-NATION SYMBOL	TRADE MFG. & ENG. PART NO.	DIAGRAM	WINDING	WIRE SIZE	TURNS	DC RESISTANCE IN OHMS	REMARKS
L122 L123	Ohmite Z-50		Single			0.95 \pm 10%	Inductance: 7 μ h \pm 10%
L201	107-B-310					400	Inductance: 11 h \pm 10% Current: 75 ma Spec MIL-T-27
L701	107-B-645		Single				Inductance: 20 μ h \pm 10%

TABLE 6-8. CROSS REFERENCE BETWEEN SYMBOL NUMBER AND FIGURE LOCATION

SYMBOL NO.	FIGURE NO.	SYMBOL NO.	FIGURE NO.	SYMBOL NO.	FIGURE NO.
AT101	6-13	C156	6-9	L102	6-11
C101-1	6-24	C157	6-9	L103	6-11
C102	6-24	C158	6-9	L104	6-11
C103-1	6-24	C159	2-5	L105	6-11
C104	6-24	C160	2-5	L106	6-24
C105-1	6-18	C161	2-5	L107	6-24
C106	6-11	C162	2-5	L108	6-24
C107-1	6-11	C163	2-5	L109	2-2
C108	6-11	C164	2-5	L110	2-2
C109-1	6-11	C165	2-6	L111	6-7
C110	6-11	C166	2-6	L112	2-3
C111	6-24	C167	6-24	L113	6-7
C112	6-24	C168	6-24	L114	6-7
C113	6-24	C169	6-24	L115	6-6
C114	6-24	C170	2-6	L116	6-7
C115	6-24	C201	6-21	L117	6-5
C116	6-24	C202	6-21	L118	6-5
C117	6-24	C203	6-21	L119	6-24
C118	6-24	C204	6-21	L120	6-24
C119	6-10	C601	2-11	L121	6-9
C120	6-8	C602	2-11	L122	6-24
C121	6-8	C701	6-23	L123	6-24
C122	6-8	C702	6-23	L124	2-6
C123	6-10	CR101	2-6	L201	6-21
C124	6-8	CR102	2-6	L701	6-23
C125	6-24	E112	4-1	M101	4-1
C126	2-2	E113	4-1	N102	4-1
C127	2-2	E114	4-1	N103	4-1
C128	2-2	E115	4-1	N104	4-1
C129	6-5	E116	4-1	O103	4-1
C130	6-7	E117	4-1	P101	6-13
C131	6-7	E118	4-1	P102	6-13
C132	6-7	E119	4-1	P103	2-8
C133	6-7	E120	4-1	P104	6-26
C134	6-5	F101	4-1	P105	6-26
C135	2-4	F102	4-1	P106	6-26
C136	2-4	F104	1-1	P107	6-26
C137	6-24	F103	1-1	P108	1-1
C128	6-24	H101	6-2	P109	1-1
C139	6-5	I101	4-1	P110	1-1
C140	6-5	J101	4-1	P801	1-1
C141	6-24	J102	4-1	P1001	6-26
C142	6-24	J103	2-8	R101-1	6-24
C143	6-24	J105	4-1	R102	6-24
C144	6-24	J201	6-21	R103-1	6-24
C145	6-24	J202	6-21	R104	6-24
C146	6-24	J301	6-22	R105-1	2-2
C147	6-24	J302	6-22	R106	2-2
C148	6-24	J401	6-24	R107-1	6-24
C149	6-24	J402	6-24	R108	6-24
C150	6-24	J501	6-25	R109-1	6-24
C151	2-9	J502	6-25	R110-1	6-24
C152	2-9	J601	6-24	R111	6-24
C153	2-9	J701	6-23	R112	6-24
C154	2-9	J702	6-23	R113	6-24
C155	6-9	L101	6-11	R114	6-7
				R115	6-7

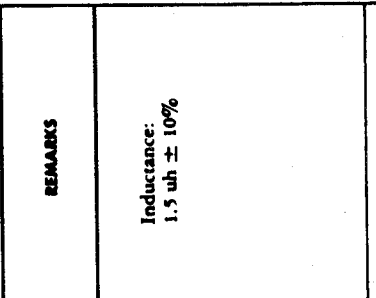
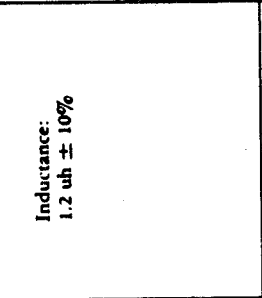
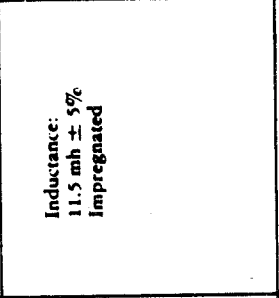
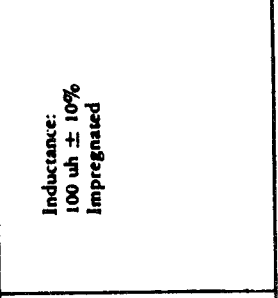
TABLE 6-8. CROSS REFERENCE BETWEEN SYMBOL NUMBER AND FIGURE LOCATION (Continued)

SYMBOL NO.	FIGURE NO.	SYMBOL NO.	FIGURE NO.	SYMBOL NO.	FIGURE NO.
R116	6-7	R151	2-5	S101	4-1
R117	6-7	R152	2-5	S102	6-16
R118	6-7	R153	2-5	S103	6-13
R119	6-7	R154	2-5	T201	6-21
R120	6-7	R155	2-5	TB101	6-16
R121	6-7	R156	2-5	V101	6-19
R122	2-3	R157	6-13	V102	6-19
R123	6-7	R158	2-5	V103	6-19
R124	2-4	R159	2-5	V104	6-19
R125	2-7	R160	2-5	V105	6-19
R126	6-24	R161	2-5	V106	6-19
R127	4-1	R162	2-5	V107	6-19
R128	2-7	R163	2-5	V108	6-19
R129	2-7	R164	2-5	V201	6-21
R130	6-6	R165	6-17	W101-1	1-1
R131	6-20	R166	2-6	W102	6-19
R132	6-20	R167	2-6	W103	6-19
R133	6-20	R168	2-6	W104	1-1
R134	6-20	R169	6-13	W105	1-1
R135	6-20	R170	2-6	W106	1-1
R136	6-20	R171	2-6	W108	1-1
R137	6-20	R172	6-13	XF101	6-13
R138	6-20	R173	6-17	XF102	6-13
R139	6-20	R174	6-24	XI101	6-13
R140	6-20	R175	6-24	XV101	6-8
R141	6-10	R176	6-9	XV102	6-6
R142	6-24	R201	6-21	XV103	6-6
R143	6-24	R301	6-22	XV104	6-6
R144	2-7	R302	6-22	XV105	6-9
R145	6-9	R303	6-22	XV106	6-17
R146	6-9	R401	6-24	XY101	6-9
R147	6-9	R402	6-24	Y101	6-19
R148	6-9	R403	6-24		
R149	2-9	R501	6-25		
R150	2-9	R701	6-23		

Note: Tables 7-4A and 7-4 of the parts list section have been corrected by means of the following supplementary table to cover the AN/URM-25G. Always refer to the supplementary tables for a given item first as it completely supersedes any corresponding listing in the basic table. If no information is shown for a given item, then refer to the basic table for the required information.

TABLE 7-4AA. SUPPLEMENTARY COMBINED PARTS AND SPARE PARTS LIST

SYMBOL DESIG.	NAME OF PART AND DESCRIPTION	FUNCTION	JAN AND (NAVY TYPE) NO.	STAND. NAVY AND (SIGNAL CORPS) STOCK NC.	MFR. & MFR'S DESIG.	CON- TRACTOR DRAWING PART NO.	ALL SYMBOL DESIG. INVOLVED	QUAN. PER EQUIP.
C101-1	CAPACITOR, fixed: mica dielectric; single section; 10 uuf $\pm 10\%$; 300 vdcw; Spec MIL-C-5/1	V101 grid blocking capacitor, band A	CM15B100K	N16-C026025-754			C101-1, 103-1	2
C102	CAPACITOR, variable: temperature compensated N650ppm/ $^{\circ}$ C, ceramic dielectric; rotary type; single section; 4.0 uuf to 30uuf; 500 vdcw; Spec MIL-C-81	Carrier oscillator band A trimmer	CV11D300				C102, 108, 110, 112, 114, 116	6
C104	CAPACITOR, variable: ceramic dielectric; rotary type; single section; 3.0uuf to 12.0uuf; 500 vdcw; Spec MIL-C-81	Carrier oscillator band B trimmer	CV11A120				C104, 106	2
C106	Same as C104	Carrier oscillator band C trimmer						
C117	CAPACITOR, fixed: ceramic dielectric; temperature compensated N750 ppm/ $^{\circ}$ C; 10uuf ± 0.5 uuf; 500 vdcw; Spec MIL-C-20	Carrier oscillator band H fixed trimmer	CC20UJ101D				C117	1
C120	CAPACITOR, fixed: ceramic dielectric; stand-off type; 1000uuf $\pm 20\%$; 500 vdcw; power factor 2.5% @ 1 KC; special temp. coeff, 1-1/64" lg x 5/16" diam; one 1/4" - 28 thd axial screw term. 3/8" lg; one axial post term; internally grounded; insulated; Spec MIL-C-11015	V101 plate circuit RF bypass capacitor	CK80AW102M				C120, 125, 126, 137, 138, 141, 142, 143, 144, 145, 151, 152	12
C122	CAPACITOR, fixed: ceramic dielectric; feed-through type; 1000 uuf $\pm 20\%$; 500 vdcw; power factor 2.5% @ 1 KC; special temp coeff, 3/4" lg x 3/16" diam; 2 axial wire leads each terminated in 1/8" lg loop; one 1/4" - 28 x 7/32" lg axial screw for mtg; insulated; Spec MIL-C-11015	V101 plate circuit bypass capacitor (feed thru)	CK70AW102M				C122, 124, 127, 128, 146, 147, 148, 149, 150, 153, 154, 168, 169	13

TABLE 7-4AA. SUPPLEMENTARY COMBINED PARTS AND SPARE PARTS LIST (Cont'd.)

PARTS								
SYMBOL DESIG.	NAME OF PART AND DESCRIPTION	FUNCTION	JAN AND (NAVY TYPE) NO.	STAND. NAVY AND (SIGNAL CORPS) STOCK NO.	MFR. & MFR'S DESIG.	CON- TRACTOR DRAWING PART NO.	ALL SYMBOL DESIG. INVOLVED	QUAN- PER EQUIP.
CAPACITORS (Cont'd.)								
C125	Same as C120	V101 B+ filter capacitor						
C126	Same as C120	V101 heater filter capacitor						
C127	Same as C122	V101 B+ RF filter capacitor (feed-thru)						
C128	Same as C122	V101 heater RF filter capacitor (feed-thru)						
C132	CAPACITOR, fixed; electrolytic; 35 uf; 25 vdcw; tolerance -10, +100 percent; polarized; aluminum case; Spec MIL-C-62	V103 cathode bypass	CE10C350F				C132	1
C137	Same as C120	VTVM (V104) output decoupling capacitor						
C138	Same as C120	VTVM (V104)						
C141	Same as C120	V102 and V103 B+ RF filter capacitor						
C142	Same as C120	Modulation input RF filter capacitor						
C143	Same as C120	V102 and V103 and V104 heater RF filter capacitor						
C144	Same as C120	V103 screen voltage RF filter capacitor						
C145	Same as C120	VTVM (V104) output RF filter capacitor						
C146	Same as C122	V102 and V103 B+ RF filter capacitor (feed-thru)						
C147	Same as C122	Modulation input RF filter capacitor (feed-thru)						
C148	Same as C122	V102, V103 and V104 heater RF filter capacitor (feed-thru)						
C149	Same as C122	V103 screen voltage RF filter capacitor (feed-thru)						
C150	Same as C122	VTVM (V104) output RF filter capacitor (feed-thru)						
C151	Same as C120	V105 B+ RF filter capacitor						
C152	Same as C120	V105 output RF filter capacitor						

TABLE 7-4AA SUPPLEMENTARY COMBINED PARTS AND SPARE PARTS LIST (Cont'd.)

PARTS									
SYMBOL DESIG.	NAME OF PART AND DESCRIPTION	FUNCTION	JAN AND (NAVY TYPE) NO.	STAND. NAVY AND (SIGNAL CORPS) STOCK NO.	MFR. & TRACTOR MFR'S DESIG. PART NO.	CON- DRAWING PART NO.	ALL SYMBOL NO.	QUAN. PER EQUIP.	
CAPACITORS (Cont'd.)									
C153	Same as C122	V105 B± RF filter capacitor (feed-thru)							
C154	Same as C122	V105 output RF filter capacitor (feed-thru)							
C204	CAPACITOR, fixed: paper dielectric, 0.15 uf ±10%; 400 vdcw; mounting clamp soldered to case; Spec MIL-C-25	L201 resonating capacitor	CP10A1KE 154K3				C204	1	
CRYSTAL UNITS									
CR101	CRYSTAL UNIT, RECTIFYING: germanium crystal; 50 ma. max. avg. fwd current, 125 piv. 400 ma. surge. Spec MIL-E-1/993A	Audio voltage rectifier	IN277				CR101, 102	2	
ZENER DIODES									
CR201	DIODE, ZENER; silicon; 6.8v ±5% at 370 ma; dissipation 10w; Spec MIL-S-19500/124C	Filament voltage regulator	1N2970B				CR201, 202	2	
CR202	Same as CR201	Filament voltage regulator							
RESISTORS									
R104	RESISTOR, fixed: composition; 3.3K ±10%; 1/2W, MIL-R-11/2	Band B, V101 cathode resistor	RC20GF332K				R104	1	
R111	RESISTOR, fixed: composition; 22K ±10%; 1/2W MIL-R-11/2	Band F, V101 grid leak resistor	RC20GF223K				R111,150, 168	3	
R131	RESISTOR, fixed: film, high stability; 61.8 ohms ±1%; 1/10W; 200 max rv; insulated; Spec MIL-R-10509	p/o step attenuator	RN55D61R8F				R131	1	
R132	RESISTOR, fixed: film, high stability; 495 ohms ±1%; 1/10W; 200 max rv; insulated; Spec MIL-R-10509	p/o step attenuator	RN55D495OF				R132,134, 136, 138, 140	5	
R133	RESISTOR, fixed: film, high stability; 61.1 ohms ±1%; 1/10W; 200 max rv; insulated; Spec MIL-R-10509	p/o step attenuator	RN55D61R1F				R133,135, 137, 139	4	

CHANGE 6

7-0CC

TABLE 7-4AA. SUPPLEMENTARY COMBINED PARTS AND SPARE PARTS LIST (Cont'd.)

PARTS								
SYMBOL DESIG.	NAME OF PART AND DESCRIPTION	FUNCTION	JAN AND (NAVY TYPE) NO.	STAND. NAVY AND (SIGNAL CORPS) STOCK NO.	MFR. & MFR'S DESIG.	CON- TRACTOR DRAWING PART NO.	ALL SYMBOL DESIG. INVOLVED	QUAN- PER EQUIP.
R141	RESISTOR, fixed: film high stability; 55.0 ohms $\pm 1\%$; 1/10W; 200 max rv; insulated; Spec MIL-R-10509	p/o step attenuator	RN55D55R0F				R141	1
R150	Same as R111	V105 output RF filter resistor						
R168	Same as R111	V107 cathode resistor						
R202	RESISTOR, fixed: wire wound; 7.5 ohms $\pm 5\%$; 22W; Spec MIL-R-26	Regulated filament supply series drooping resistor	RW21V7R5				R202	1
SWITCHES								
S101	SWITCH, rotary: 2 section; 4 position; 1-1/2" wd x 1-5/16" high x 2-7/16" lg; single hole mtg; bushing 3/8" -32 x 1/4" lg; 1/4" diam rd shaft 1-1/4" lg; non-turn device; Spec MIL-S-3786A/3	Carrier range switch			(27) 107-B-646	107-B-646	S101	1
S102	SWITCH, rotary: 4 section; 5 position; 2 poles per section on 3 sections; 2 stator contacts on 1 section; 2-7/8" lg x 1-1/2" wd x 1-3/8" high; shorting type; solder lug term; single hole mtg; bushing 3/8" -32 x 1/4" lg; 1/4" diam rd shaft 7/8" lg; non-turn device; Spec MIL-S-3786A/3	Mod, Xtal, & Meter Selector			(27) 107-C-647	107-C-647	S102	1
TRANSFORMERS								
T201	TRANSFORMER, power filament and plate type, 115v, 50-1000 cycle; single ph; three output windings; sec #1-6.5v at 3.75 amp; sec #2-450V CT at 70 ma sec #3-12.6v at 1.75 amp; working voltage to ground, pri-165V-RMS test 500V, sec 1-10V -RMS test 500V; sec #2-320V-RMS test 900V; sec #3-20V-RMS test 500V; hermetically sealed rect case; 3" lg x 2-7/8" wd x 3-3/4" high exci term; nine 1/2" high standoff term; four No. 8-32 x 1/2" lg mtg bolts on 2" x 2-3/8" mtg c; Spec MIL-T-27, Grade 1, Class A, Family 03	Power transformer			(28) 107-B-309	107-B-309	T201	1
TERMINAL BOARDS								
TB103	BOARD, terminal: resistor, capacitor, choke mounting board; 6 feed-through lug term., 4 stand-off lug term.; XXX phenolic board 0.093" thk; irregular shape; 3-13/32" lg x 2-1/8" wd o/a; two 0.128" dia holes on 1-9/16" mtg c	RF bracket terminal board assy			(29) 107-B-720	107-B-720	TB103	1

Note:
Table 7-4. of the parts list section has been corrected by means of the following supplementary table. Always refer to the supplementary table for a given item first as it completely supersedes any corresponding listing in the basic table. If no information is shown for a given item, then refer to the basic table for the required information.

TABLE 7-4A. SUPPLEMENTARY COMBINED PARTS AND SPARE PARTS LIST

PARTS		PARTS						
SYMBOL DESIG.	NAME OF PART AND DESCRIPTION	FUNCTION	JAN. AND (NAVY TYPE) NO.	STANDARD NAVY AND (SIGNAL CORP.) STOCK NO.	MFR. & MFR'S DESIGNATION	CONTRACTOR DRAWING PART NO.	ALL SYMBOL DESIG. INVOLVED	QUAN. PER EQUIP.
Capacitors								
C101-1	CAPACITOR, fixed; mica dielectric; single section; 10 uuf ±10%; 300vdcw; Spec MIL-C-5/1	V101 grid blocking capacitor, band A	CM15B100K	N16-C026025-7541			C101-1, 103-1, 117	3
C103-1	Same as C101-1	V101 grid blocking capacitor, band B						
C105-1	CAPACITOR, fixed; mica dielectric; single section; 18 uuf ±10%; 300vdcw; Spec MIL-C-5/1	V101 grid blocking capacitor, band C	CM15B180K	N16-C026005-9557			C105-1	1
C107-1	CAPACITOR, fixed; mica dielectric; single section; 36 uuf ±10%; 300vdcw; Spec MIL-C-5/1	V101 grid blocking capacitor, band D	CM15B360K	For replacement use N5910-636-2085			C107-1, 109-1	2
C109-1	Same as C107-1	V101 grid blocking capacitor, band E						
C115	CAPACITOR, fixed; mica dielectric; single section; 330 uuf ±10%; 300vdcw; Spec MIL-C-5/1	V101 grid blocking capacitor, band H	CM15B331K	For replacement use N5910-187-2793			C115	1
C117	Same as C101-1	Carrier oscillator band H fixed trimmer						
C130	CAPACITOR, fixed; paper dielectric; 0.01uf ±20%; 300 vdcw; JAN-C-91	V102 output coupling capacitor	CN22AX103M	For replacement use N5910-666-9119			C130, 155, 159, 164, 165	5
C131	CAPACITOR, fixed; mica dielectric; single section; 150 uuf ±10%; 300vdcw; Spec MIL-C-5/1	V103 input coupling capacitor	CM15B151K	For replacement use N5910-253-9132			C131	1
C135	CAPACITOR, fixed; mica dielectric; 10,000uuf ±5%; 300vdcw; JAN-C-5	V103 output coupling capacitor	CM35D103J	For replacement use N5910-184-5995			C135	1
C136	CAPACITOR, fixed; mica dielectric; single section; 510uuf ±5%; 300 vdcw; Spec MIL-C-5/1	V103 RF output coupling capacitor	CM15B511J	For replacement use N5910-280-7185			C136	1
C160	CAPACITOR, fixed; mica dielectric; 1000uuf ±2%; 500 vdcw; MIL-C-5/1	V106 bridge capacitor	CM25D102G	N16-C031080-2522			C160, 161	2
C161	Same as C160	V106 bridge capacitor						
C162	CAPACITOR, fixed; paper dielectric; 0.1uf ±20%; 400 vdcw; JAN-C-91	V106 output coupling capacitor	CN43EE104M	N16-C045805-6260			C162, 163	2
C166	CAPACITOR, fixed; paper dielectric; 0.2uf ±20%; 120 vdcw; JAN-C-91	V107 output coupling capacitor	CN43EY204M	For replacement use N5910-197-3756			C166, 167	2

TABLE 7-4A. SUPPLEMENTARY COMBINED PARTS AND SPARE PARTS LIST (Cont.)

PARTS									
SYMBOL DESIG.	NAME OF PART AND DESCRIPTION	FUNCTION	JAN. AND (NAVY TYPE) NO.	STANDARD NAVY AND (SIGNAL CORP.) STOCK NO.	MFR. & MFR'S DESIG. NATION	CON- TRACTOR DRAWING PART NO.	ALL SYMBOL DESIG. INVOLVED	QUAN. PER EQUIP.	
Crystal Units									
CR101	CRYSTAL UNIT, RECTIFYING: germanium crystal; 7/8 in lg; 1/4 in diam; 2 axial wire leads, MIL-E-1142C	Audio voltage rectifier	1N69	N16-T051769			CR101,102	2	
Fuses									
F101	FUSE, cartridge: 1 amp; open in one hour at 135% load; rated continuous at 110% load; 250V; one time; glass body; ferrule term: 1 1/4" lg x 1/4" diam o/a; term. 5/16" lg x 1/4" diam; slow blowing	Line fuse	FO2G1R00B MIL-F-15160C	N17-F-14310-380			F101,102, 103,104	4	
Connectors (Jack and Receptacles)									
J103	CONNECTOR, receptacle: 1 round coaxial female contact; straight	Connector for step attenuator AT101	UG-1094/U	N17-C073108-5259			J103,301 302,401, 402,501, 502,601, 701,702	10	
J104	Deleted								
Meters									
M101	METER, multiscale: DC; range 0 to 100 micro-amps; hermetically sealed round metal flush mtg case; 2-3/16" barrel diam x 1 3/8" deep behind panel; 2-1/16" diam flange	RF Output and percent modulation meter		N17-M034601-1276	(24) TI 331 Trad Dwg No. 107-A-9	107-B-670	M101	1	
Connectors, Plugs									
P801	CONNECTOR, adapter: male one end, female other end; coax male type N at one end, coax female type BNC other end; straight type; adapts female type N to male type BNC connector; 3/4" diam x 1-9/16" lg o/a; 52 ohms impedance; cylindrical brass silver pl; molded polystyrene insert	Coaxial adapter	AN type UG-201A/U	For replacement use N5935-258-1763			P801	1	
Resistors									
R101-1	RESISTOR, fixed: composition; 220K ±10%; 1/2W; MIL-R-11/2	Band A, V101 grid leak resistor	RC20GF224K	For replacement use N5905-192-0667			R101-1	1	

Resistors (cont)

R102	RESISTOR, fixed: composition; 47K ± 10%; 1/2 W; MIL-R-11/2	Band A, V101 cathode resistor.	RC20GF473K	N16-R050479-0435	R102, 156,161	3
R103-1	RESISTOR, fixed: composition; 150K ± 10%; 1/2 W; MIL-R-11/2	Band B, V101 grid leak resistor	RC20GF154K	For replacement use N5905-195-9483	R103-1	1
R104	RESISTOR, fixed: composition; 22K ± 10%; 1/2 W; MIL-R-11/2	Band B, V101 cathode resistor	RC20GF223K	For replacement use N5905-171-2004	R104,111, 150,168	4
R105-1	RESISTOR, fixed: composition; 33K ± 10%; 1/2 W; MIL-R-11/2	Band C, V101 grid leak resistor	RC20GF333K	For replacement use N5905-171-1998	R105-1, 117	2
R106	RESISTOR, fixed: composition; 18K ± 10%; 1/2 W; MIL-R-11/2	Band C, V101 cathode resistor	RC20GF183K	For replacement use N5905-279-3500	R106	1
R107-1	RESISTOR, fixed: composition; 10K ± 10%; 1/2 W; MIL-R-11/2	Band D, V101 grid leak resistor	RC20GF103K	For replacement use N5905-185-8510	R107-1, 112	2
R108	RESISTOR, fixed: composition; 6800 ohms ± 10%; 1/2 W; MIL-R-11/2	Band D, V101 cathode resistor	RC20GF682K	For replacement use N5905-195-9493	R108	1
R109-1	RESISTOR, fixed: composition; 2200 ohms ± 10%; 1/2 W; MIL-R-11/2	Band E, V101 grid leak resistor	RC20GF222K	For replacement use N5905-279-1876	R109-1 110-1, 116,149	4
R110-1	Same as R109-1	Band E, V101 cathode resistor				
R111	Same as R104	Band F, V101 grid leak resistor				
R112	Same as R107-1	Band G, V101 grid leak resistor				
R113	RESISTOR, fixed: composition; 4700 ohms ± 10%; 1/2 W; MIL-R-11/2	Band H, V101 grid leak resistor	RC20GF472K	For replacement use N5905-279-3504	R113,144	2
R114	RESISTOR, fixed: composition; 100K ± 10%; 1/2 W; MIL-R-11/2	V102 grid resistor	RC20GF104K	For replacement use N5905-195-6761	R114,146, 160,164	4
R115	RESISTOR, fixed: composition; 160 ohms ± 5%; 1/2 W; MIL-R-11/2	V102 cathode resistor	RC20GF161J	N16-R049633-0438	R115	1
R116	Same as R109-1	L111 damping resistor				
R117	Same as R105-1	V102 screen grid resistor				
R118	RESISTOR, fixed: composition; 470 ohms ± 5%; 1/2 W; MIL-R-11/2	V102 plate resistor	RC20GF471J	N16-R049768-0438	R118	1

TABLE 7-4A. SUPPLEMENTARY COMBINED PARTS AND SPARE PARTS LIST (Cont.)

PARTS									
SYMBOL DESIG.	NAME OF PART AND DESCRIPTION	FUNCTION	JAN. AND (NAVY TYPE) NO.	STANDARD NAVY AND (SIGNAL CORP.) STOCK NO.	MFR. & MFR.'S DESIG- NATION	CON- TRACTOR DRAWING PART NO.	ALL SYMBOL DESIG. INVOLVED	QUAN PER EQUIP.	
Resistors (cont)									
R120	RESISTOR, fixed: composition; 510 ohms $\pm 5\%$; $1/2$ W; MIL-R-11/2	L113 damping resistor	RC20GF511J	N16-R049786-0438			R120	1	
R121	RESISTOR, fixed: composition; 51K $\pm 5\%$; $1/2$ W; MIL-R-11/2	p/o V103 grid resistor	RC20GF513J	N16-R050497-0419			R121	1	
R122	RESISTOR, fixed: composition; 10K $\pm 5\%$; $1/2$ W; MIL-R-11/2	p/o V103 grid resistor	RC20GF103J	N16-R050281-0725			R122,128, 142	3	
R123	RESISTOR, fixed: composition; 270 ohms $\pm 5\%$; $1/2$ W; MIL-R-11/2	V105 cathode resistor	RC20GF271J	N16-R049687-0321			R123	1	
R124	RESISTOR, fixed: composition; 1500 ohms $\pm 10\%$; $1/2$ W; MIL-R-11/2	L115 damping resistor	RC20GF152K	For replacement use N5905-279-1757			R124	1	
R125	RESISTOR, fixed: composition; 470K $\pm 10\%$; $1/2$ W; MIL-R-11/2	p/o V104 biasing system	RC20GF474K	For replacement use N5905-279-2515			R125,151, 166	3	
R126	RESISTOR, fixed: composition; 15K $\pm 5\%$; $1/2$ W; MIL-R-11/2	p/o V104 biasing system	RC20GF153J	N16-R050335-0438			R126,170, 171	3	
R128	Same as R122	p/o V104 load resistor							
R129	RESISTOR, fixed: composition; 100 ohms $\pm 10\%$; $1/2$ W; MIL-R-11/2	J101 separating resistor	RC20GF101K	For replacement use N5905-190-8889			R129	1	
R142	Same as R122	Modulation input RF filter resistor							
R143	RESISTOR, fixed: composition; 270 ohms $\pm 10\%$; $1/4$ W; MIL-R-11/2	V103 screen voltage RF filter resistor	RC20GF271K	For replacement use N5905-171-2006			R143	1	
R144	Same as R113	V104 output RF filter resistor							
R145	RESISTOR, fixed: composition; 27K $\pm 10\%$; $1/2$ W; MIL-R-11/2	V105 screen grid resistor	RC20GF273K	For replacement use N5905-195-9482			R145	1	
R146	Same as R114	V105 plate resistor							
R147	RESISTOR, fixed: composition; 270K $\pm 10\%$; $1/2$ W; MIL-R-11/2	V105 first grid resistor	RC20GF274K	For replacement use N5905-190-8865			R147,148	2	

Resistors (cont)						
R148	Same as R147	V105 third grid resistor				
R149	Same as R109-1	V105 B+ RF filter resistor				
R150	Same as R104	V105 output RF filter resistor				
R151	Same as R125	V106 grid resistor				
R156	Same as R102	V106 degeneration resistor				
R158	RESISTOR, fixed: composition; 1000 ohms $\pm 10\%$; $1/2$ W; MIL-R-11/2	p/o V106 cathode resistor	RC20GF102K	For replacement use N5905-195-6806	R158, 162 167	3
R159	RESISTOR, fixed: composition; 20K $\pm 5\%$; $1/2$ W; MIL-R-11/2	p/o V106 cathode resistor	RC20GF20J	N16-R050362-0433	R159	1
R160	Same as R114	V106 plate resistor				
R161	Same as R102	V106 plate resistor				
R162	Same as R158	V106 cathode resistor				
R163	RESISTOR, fixed: composition; 1 meg-ohm $\pm 10\%$; $1/2$ W; MIL-R-11/2	V106 grid resistor	RC20GF105K	For replacement use N5905-192-0390	R163	1
R164	Same as R114	p/o V106 output divider				
R166	Same as R125	V107 grid resistor				
R167	Same as R158	V107 biasing resistor				
R168	Same as R104	V107 cathode resistor				
R170	Same as R126	p/o modulation metering system				
R171	Same as R126	p/o modulation metering system				
R176	RESISTOR, fixed: composition; 3.3 megohms $\pm 10\%$; $1/2$ W; MIL-R-11/2	Xtal, cal coupling resistor	RC20GF335K	For replacement use N5905-279-1883	R176	1
R177	Same as R129	V107 series grid resistor				

TABLE 7-4A. SUPPLEMENTARY COMBINED PARTS AND SPARE PARTS LIST (Cont.)

PARTS								
SYMBOL DESIG.	NAME OF PART AND DESCRIPTION	FUNCTION	JAN. AND (NAVY TYPE) NO.	STANDARD NAVY AND (SIGNAL CORP.) STOCK NO.	MFR. & MFR'S DESIG. NATION	CON- TRACTOR DRAWING PART NO.	ALL SYMBOL DESIG. INVOLVED	QUAN PER EQUIP.
Electron Tubes								
V104	ELECTRON TUBE: double diode; MIL-E-1B	Carrier volt meter	5726/6AL5W	N16-T075726			V104	1
V105	ELECTRON TUBE: pentagrid, MIL-E-1B	Xtal calibrator	5750/6BE6W	N16-T075750			V105	1
V106	ELECTRON TUBE: double triode; MIL-E-1B	Modulation oscillator	5814A	N16-T075814-0005			V106	1
V108	ELECTRON TUBE: voltage regulator; MIL-E-1B	Voltage stabilizer	0A2W/A	N16-T052001-0003			V108	1
V201	ELECTRON TUBE: full-wave high-vacuum rectifier; MIL-E-1B	Power supply rectifier	6X4W/A	N16-T056840-0060			V201	1
Sockets								
XF101	FUSE HOLDER: extractor post type; for single 3AG cartridge fuse; black bakelite; 250W at 15 amp; 2-9/64" lg x 11/16" diam o/a; 1/2" x 1/2" hole thru bakelite body; for panel hole mtg; 3/32" hole drilled through cap	Holder for fuse F101			(3) HKP. HRWEJ		XF101,102	2
XF102	Same as XF101	Holder for fuse F102						
Accessories								
W101-1	CABLE ASSEMBLY, POWER, ELECTRICAL: SJ cable, 3 conductor, stranded No. 18 AWG, rubber insulation, cotton warp, rubber jacket, 6 ft lg o/a; type UP-121/M connector plug at one end	AC line cable		Assemble from Component parts		142-B-25	W101-1	1
W108	CABLE, POWER, ELECTRICAL: type SJ; 3 conductor, stranded No. 18 AWG; rubber insulation; cotton warp; rubber jacket	p/o W101-1		G6145-299-6256			W108	6 ft
P110	CONNECTOR, PLUG: 3 contacts, male; 2 flat contacts; 1 U-shape contact; polarized; grounded; straight type; 1/2" lg. x 23/32" wide x 1-17/32" high overall, excluding protruding contacts; 10 amps, 250V; rectangular body, steel, cadmium plated; glass-filled alkylid resin insert; 0.45" dia. max. cable opening; 3rd blade removable	p/o W101-1	UP-121/M	N17-C071464-8682			P110	1
P1001	CONNECTOR, ADAPTER: straight type; BNC type to mate with plug UG-88/U one end; other end to mate with type 49120 receptacle in accordance with U.S. Naval Research Laboratories Dwg RA49F215; 17/8" lg x 3/4" diam o/a; cylindrical shaped body; brass, silver pl; molded Teflon insert	Adapter from type type UG-88/U BNC plug to type 49120		Low failure item. If required, requisition from ESO referencing NAVSHIPS 900.180A			P1001	1

TABLE 7-4AA. SUPPLEMENTARY COMBINED PARTS AND SPARE PARTS LIST (AN/URM-25H ONLY)

PARTS									
SYMBOL DESIG.	NAME OF PART AND DESCRIPTION	FUNCTION	JAN AND (NAVY TYPE) NO.	STAND. NAVY AND (SIGNAL CORPS) STOCK NO.	MFR. & MFR'S DESIG.	CON- TRACTOR DRAWING PART NO.	ALL SYMBOL DESIG. INVOLVED	QUAN PER EQUIP.	
C1	Capacitor, Fixed: Electrolytic, 2200 uf, -10 +50 uf, 10 VDCW	V101 Voltage Doubler			(21) 34D228F- 010JJ4	V306200- 03	C1, C2	2	
C2	Same as C1	V101 Voltage Doubler							
C171	Same as C127	V101 Heater RF Filter Capacitor (Feed-Thru)						11	
C172	Same as C127	V101 Heater RF Filter Capacitor (Feed-Thru)							
CR1	Diode, Silicon: Power Rectifier Spec MIL-S-19500/ 202	V101 Filament Full Wave Rectifier	1N540				CR1, CR2	2	
CR2	Same as CR1	V101 Filament Full Wave Rectifier							
CR3	Diode, Zener: 6.2 V Spec MIL-S-19500/272	V101 Voltage Regulator	1N3998A				CR3	1	
R1	Resistor Fixed: Wirewound, 15 ohms, ±5%, 5W Spec MIL-R-26	V101 Voltage Regulator	RW55G150				R1, R2	2	
R2	Same as R1	V101 Voltage Regulator							
TB1	Board, Terminal: Resistor, Capacitor, Diode Mtg Board; 8 standoff lug terminals; XXX phenolic Board .125" thk, Irregular shape 4" lg x 2 1/2" wd O/A. .149" Dia. Holes on 1.812 x 3.437" Mtg/C	Oscillator Filament Regulator Board			A84000- 250		TB1	1	



SECTION 7

PARTS LIST

- Table 7-1 Weights and Dimensions of Spare Parts Boxes
- Table 7-2 Shipping Weights and Dimensions of Spare Parts Boxes
- Table 7-3 List of Major Units
- Table 7-4 Combined Parts and Spare Parts List
- Table 7-5 Cross Reference Parts List
- Table 7-6 List of Manufacturers
- Table 7-7 Applicable Color Codes and Miscellaneous Data

TABLE 7-1. WEIGHTS AND DIMENSIONS OF SPARE PARTS BOXES

EQUIPMENT SPARES						STOCK SPARES				
ACTIVITY	OVERALL DIMENSIONS (INCHES)			VOLUME (CU IN)	WEIGHT (LBS)	OVERALL DIMENSIONS (INCHES)			VOLUME (CU IN)	WEIGHT (LBS)
	HEIGHT	WIDTH	DEPTH			HEIGHT	WIDTH	DEPTH		
BUSHIPS	9	8	3	216	2	*	*	*	*	*
MARINE CORPS						*	*	*	*	*

* Shipped in bulk quantities

TABLE 7-2. SHIPPING WEIGHTS AND DIMENSIONS OF SPARE PARTS BOXES

EQUIPMENT SPARES						STOCK SPARES				
ACTIVITY	OVERALL DIMENSIONS (INCHES)			VOLUME (CU IN)	WEIGHT (LBS)	OVERALL DIMENSIONS (INCHES)			VOLUME (CU IN)	WEIGHT (LBS)
	HEIGHT	WIDTH	DEPTH			HEIGHT	WIDTH	DEPTH		
BUSHIPS	9	8	3	216	2	*	*	*	*	*
MARINE CORPS						*	*	*	*	*

* Weight and dimensions determined as shipped

ORIGINAL

TABLE 7-3. LIST OF MAJOR UNITS

SYMBOL GROUP	QUANTITY	NAME OF MAJOR UNIT	NAVY TYPE OR A-N DESIGNATION
101 to 199	1	RF Signal Generator	SG-85/URM-25D
201 to 299	1	Power Supply	PP-977/URM-25D
301 to 399	1	(5:1) Fixed Attenuator	CN-223/URM-25D
401 to 499	1	(10:1) Fixed Attenuator	CN-224/URM-25D
501 to 599	1	Impedance Adapter	MX-1487/URM-25D
601 to 699	1	Test Lead	CX-1363/U
701 to 799	1	Antenna Simulator	SM-35/URM-25
P801	1	Coaxial Adapter	UG-201A/U
W104	1	Output RF Cable	CG-409/U (3'11")
W105, W106	2	Output RF Cable	CG-409/U (0'5")
P901	1	Connector, Adapter	UG-684A/U
P1001	1	Connector, Adapter	

TABLE 7-4. COMBINED PARTS AND SPARE PARTS LIST

PARTS									
SYMBOL DESIG.	NAME OF PART AND DESCRIPTION	FUNCTION	JAN. AND (NAVY TYPE) NO.	STANDARD NAVY AND (SIGNAL CORP.) STOCK NO.	MFR. & MFR'S DESIG. NATION	CON-TRACTOR DRAWING PART NO.	ALL SYMBOL DESIG. INVOLVED	QUAN PER EQUIP.	
Attenuator									
AT101	ATTENUATOR, step: unbalanced ladder network; output 50 ohms; aluminum case; 12 sides; 2 1/2" across flats x 2 1/4" thick o/a excl connector and shaft; gear driven shaft; 6 steps, 20 db per step; RF coaxial cable (RG-55/U) input, BNC connector output; four No. 4-40 mig holes 90° apart on 1 1/4" diam.	Output Voltage Attenuator			(25) AT120	107-B-672	AT101	1	
Capacitors									
C101-1	CAPACITOR, fixed: mica dielectric; single section; 10 uuf ±10%; 300 vdcw; Spec. MIL-C-5/1.	V101 grid blocking capacitor, band A	CM15B100K				C101-1, 103-1, 117	3	
C102	CAPACITOR, variable: ceramic dielectric; rotary type; single section; 3.0 uuf to 12.0 uuf; 500 vdcw; Spec. MIL-C-81.	Carrier oscillator band A trimmer	CV111A120				C102, 104, 106, 108, 110, 112, 114, 116	8	
C103-1	Same as C101-1.	V101 grid blocking capacitor band B							
C104	Same as C102.	Carrier oscillator band B trimmer							
C105-1	CAPACITOR, fixed: mica dielectric; single section; 18 uuf ±10%; 300 vdcw; Spec. MIL-C-5/1.	V101 grid blocking capacitor band C	CM15B180K				C105-1	1	
C106	Same as C102.	Carrier oscillator band C trimmer							
C107-1	CAPACITOR, fixed: mica dielectric; single section; 36 uuf ±10%; 300 vdcw; Spec. MIL-C-5/1.	V101 grid blocking capacitor band D	CM15B360K				C107-1, 109-1	2	
C108	Same as C102.	Carrier oscillator band D trimmer							

TABLE 7-4. COMBINED PARTS AND SPARE PARTS LIST (Continued)

PARTS								
SYMBOL DESIG.	NAME OF PART AND DESCRIPTION	FUNCTION	JAN. AND (NAVY TYPE) NO.	STANDARD NAVY AND (SIGNAL CORP.) STOCK NO.	MFR. & MFR'S DESIG- NATION	CON- TRACTOR DRAWING PART NO.	ALL SYMBOL DESIG. INVOLVED	QUAN. PER EQUIP.
Capacitors (cont)								
C109-1	Same as C107-1.	V101 grid blocking capacitor band E						
C110	Same as C102.	Carrier oscillator band E trimmer						
C111	CAPACITOR, fixed: mica dielectric; single section: 100 uuf ±10%; 300 vdcw; Spec. MIL-C-5/1.	V101 grid blocking capacitor band F	CM15B101K				C111	1
C112	Same as C102.	Carrier oscillator band F trimmer						
C113	CAPACITOR, fixed: mica dielectric; single section: 56 uuf ±10%; 300 vdcw; Spec. MIL-C-5/1.	V101 grid blocking capacitor band G	CM15B560K				C113	1
C114	Same as C102.	Carrier oscillator band G trimmer						
C115	CAPACITOR, fixed: mica dielectric; single section: 350 uuf ±10%; 300 vdcw; Spec. MIL-C-5/1.	V101 grid blocking capacitor band H	CM15B331K				C115	1
C116	Same as C102.	Carrier oscillator band H trimmer						
C117	Same as C101-1.	Carrier oscillator band H fixed trimmer						
C118	CAPACITOR, fixed: mica dielectric; single section: 150 uuf ±2%; 500 vdcw; Spec. MIL-C-5/2.	Carrier oscillator band H padding capacitor	CM20C151G				C118	1
C119	CAPACITOR, fixed: ceramic dielectric; single section: 2 uuf ±0.25 uuf; 500 vdcw; Spec. JAN-C-20A.	V101 output coupling capacitor	CC21CK020C				C119	1
C120	CAPACITOR, fixed: ceramic dielectric; stand-off type; 500 uuf ±20%; 500 vdcw; power factor 2.5% @ 1 mc; special temp coeff; body .520" lg x .250" dia; one No.	V101 plate circuit RF bypass capacitor			(10) 319 (H1- K-12)	107-A-418	C120	1

C121	3-48 thd axial screw term. $\frac{1}{2}$ " lg; one axial wire term. .067" dia x .386" lg; uninsulated; baked enamel coating. CAPACITOR, fixed; paper dielectric; 0.25 uf +20% -10%; 400 vdcw; characteristic fr F; hermetically sealed (glass to metal) tubular; wax impregnated; internally grounded; uninsulated; .400 in. diam x $1\frac{1}{2}$ " lg excl mtg bshg and term.; $\frac{3}{8}$ "-24 thd x $\frac{1}{2}$ " lg mtg bshg w/hex nut and lock washer; one axial wire lead.	V101 plate circuit bypass capacitor	(14) XG-1836- N	107-A- 659-2	C121, 129, 140	3
C122	CAPACITOR, fixed; ceramic dielectric; feed-through type; 1000 uuf $\pm 20\%$; 500 vdcw; power factor 2.5%; special temp coeff; $\frac{3}{8}$ " lg x $\frac{3}{8}$ " diam; 2 axial wire leads each terminated in a $\frac{1}{4}$ " lg loop; one No. 12-28 x $\frac{1}{2}$ " lg axial screw for mtg; uninsulated.	V101 plate circuit bypass capacitor (feed thru)	(10) 357 (H1- K-12)	107-A-411	C122, 124, 168, 169	4
C123	CAPACITOR, variable; air dielectric; plate meshing type; single section; 12 uuf to 479 uuf; $3\frac{1}{2}$ " lg x $2\frac{3}{4}$ " wd x $1\frac{1}{2}$ " thk; round metal shaft $\frac{1}{4}$ " diam x $\frac{3}{4}$ " lg; 27 silver plated plates; 180° counterclockwise rotation.	Main Tuning Capacitor	(20) #887594 (Special)	107-C-522	C123	1
C124	Same as C122.	V101 heater bypass capacitor				
C125	CAPACITOR, fixed; ceramic dielectric; stand-off type; 1000 uuf $\pm 20\%$; 500 vdcw; power factor 2.5% @ 1 KC; special temp. coeff; $1\frac{1}{4}$ " lg x $\frac{3}{8}$ " diam; one $\frac{1}{4}$ "-28 thd axial screw term. $\frac{3}{8}$ " lg; one axial post term; internally grounded; insulated.	V101 B + RF filter capacitor	(10) 326	100-A- 132-8	C125, 126, 137, 138, 141, 142, 143, 144, 145, 151, 152	11
C126	Same as C125.	V101 heater filter capacitor				
C127	CAPACITOR, fixed; ceramic dielectric; feed-through type; 1000 uuf $\pm 20\%$; 500 vdcw; power factor 2.5% @ 1 KC; special temp coeff; $\frac{3}{4}$ " lg x $\frac{3}{8}$ " diam; 2 axial wire leads each terminated in $\frac{1}{8}$ " lg loop; one $\frac{1}{8}$ "-28 x $\frac{3}{4}$ " lg axial screw for mtg; insulated.	V101 B + RF filter capacitor (feed-thru)	(10) 327	100-A- 129-9	C127, 128, 146, 147, 148, 149, 150, 153, 154	9
C128	Same as C127.	V101 heater RF filter capacitor (feed-thru)				
C129	Same as C121.	V102 screen bypass capacitor				
C130	CAPACITOR, fixed; paper dielectric; 0.01 uf $\pm 20\%$; 300 vdcw; Spec. MIL-C-91/2.	V102 output coupling capacitor			C130, 155, 159, 164, 165	5
C131	CAPACITOR, fixed; mica dielectric; 150 uuf $\pm 10\%$; 300 vdcw; Spec. MIL-C-5/1.	V103 input coupling capacitor			C131	1
C132	CAPACITOR, fixed; electrolytic; 25 uf; 25 vdcw; hermetically sealed in tubular aluminum case; $\frac{3}{4}$ " diam x $1\frac{1}{2}$ " lg; 2 axial solder lug term.	V103 cathode bypass capacitor	(21) Type DPS	107-A- 678	C132	1
C133	CAPACITOR, fixed; paper dielectric; 0.022 uf $\pm 10\%$; 200 vdcw; Spec. MIL-C-25A.	V103 cathode RF bypass			C133, 139	2

TABLE 7-4. COMBINED PARTS AND SPARE PARTS LIST (Continued)

PARTS								
SYMBOL DESIG.	NAME OF PART AND DESCRIPTION	FUNCTION	JAN. AND (NAVY TYPE) NO.	STANDARD NAVY AND (SIGNAL CORP.) STOCK NO.	MFGR. & MFGR'S DESIG- NATION	CON- TRACTOR DRAWING PART NO.	ALL SYMBOL DESIG. INVOLVED	QUAN- TITY PER EQUIP.
Capacitors (cont)								
C134	CAPACITOR, fixed: paper dielectric; 0.1 uf $\pm 20\%$; 400 vdcw; characteristic 1r F; hermetically sealed (glass to metal) tubular; wax impregnated; internally grounded; uninsulated; .400" diam x $\frac{3}{8}$ " lg excl mtg bshg and term.; $\frac{3}{8}$ "-24 thd x $\frac{1}{2}$ " lg mtg bshg w/hex nut and lockwasher; one axial wire lead.	V103 screen bypass			(14) XG-1816- N	107-A- 659-1	C134	1
C135	CAPACITOR, fixed: mica dielectric; 10,000 uuf $\pm 5\%$; 300 vdcw; Spec. MIL-C-5/5.	V103 output coupling capacitor	CM35D103J				C135	1
C136	CAPACITOR, fixed: mica dielectric; 510 uuf $\pm 5\%$; 300 vdcw; Spec. MIL-C-5/1.	V103 RF output coupling capacitor	CM15B511J				C136	1
C137	Same as C125.	VTVM (V104) output decoupling capacitor						
C138	Same as C125.	VTVM (V104)						
C139	Same as C133.	VTVM (V104)						
C140	Same as C121.	V102 and V103 B+ bypass						
C141	Same as C125.	V102 and V103 B+ RF filter capacitor						
C142	Same as C125.	Modulation input RF filter capacitor						
C143	Same as C125.	V102 and V103 and V104 heater RF filter capacitor						
C144	Same as C125.	V103 screen voltage RF filter capacitor						
C145	Same as C125.	VTVM (V104) output RF filter capacitor						
C146	Same as C127.	V102 and V103 B+ RF filter capacitor (feed-thru)						

C147	Same as C127.	Modulation input RF filter capacitor (feed-thru)			1	C156	
C148	Same as C127.	V102, V103 and V104 heater RF filter capacitor (feed-thru)				C157	
C149	Same as C127.	V103 screen voltage RF filter capacitor (feed-thru)				C158	
C150	Same as C127.	VTVM (V104) output RF filter capacitor (feed-thru)					
C151	Same as C125.	V105 B+ RF filter capacitor					
C152	Same as C125.	V105 output RF filter capacitor					
C153	Same as C127.	V105 B+ RF filter capacitor (feed-thru)					
C154	Same as C127.	V105 output RF filter capacitor (feed-thru)					
C155	Same as C130.	V105 screen bypass capacitor					
C156	CAPACITOR, fixed; mica dielectric; 270 uuf, $\pm 10\%$; 500 vdcw; Spec. MIL-C-5/1.	V105 feed-back capacitor	CM20B271K				
C157	CAPACITOR, fixed; ceramic dielectric; 12 uuf $\pm 2\%$; 500 vdcw; Spec. JAN-C-20A.	V105 grid capacitor	CC21CH120G				
C158	CAPACITOR, variable; ceramic dielectric; rotary type; single section; 6 uuf to 25 uuf; 500 vdcw; Spec. JAN-C-81.	V105 frequency adjusting capacitor	CV12A250				
C159	Same as C150.	V105 output coupling capacitor					
C160	CAPACITOR, fixed; mica dielectric; 1000 uuf $\pm 2\%$; 500 vdcw; Spec. MIL-C-5/1.	V106 bridge capacitor	CM25D102G			C160, 161	2
C161	Same as C160.	V106 bridge capacitor					
C162	CAPACITOR, fixed; paper dielectric; 0.1 uf $\pm 20\%$; 400 vdcw; Spec. MIL-C-91/7.	V106 output coupling capacitor	CN43EE104M			C162, 163	2
C163	Same as C162.	V106 output coupling capacitor					

CHANGE 3

TABLE 7-4. COMBINED PARTS AND SPARE PARTS LIST (Continued)

PARTS		PARTS						
SYMBOL DESIG.	NAME OF PART AND DESCRIPTION	FUNCTION	JAN. AND (NAVY TYPE) NO.	STANDARD NAVY AND (SIGNAL CORP.) STOCK NO.	MFR. & MFR'S DESIG- NATION	CON- TRACTOR DRAWING PART NO.	ALL SYMBOL DESIG. INVOLVED	QUAN. PER EQUIP.
Capacitors (cont)								
C164	Same as C130.	V106 coupling capacitor	CN43EY204M					2
C165	Same as C130.	V107 input capacitor						
C166	CAPACITOR, fixed: paper dielectric; 0.2 uf $\pm 20\%$; 120 vdcw; Spec. MIL-C-91/7.	V107 output coupling capacitor					C166, 167	
C167	Same as C166.	V107 output coupling capacitor						
C168	Same as C122.	Line filter capacitor						
C169	Same as C122.	Line filter capacitor						
C170	CAPACITOR, fixed: mica dielectric; 1000 uuf $\pm 10\%$; 500 vdcw; Spec. MIL-C-5/4.	J105 RF filter capacitor	CM30B102K				C170	1
C201	CAPACITOR, fixed: paper dielectric; 4 uf $\pm 10\%$; 600 vdcw; Spec. MIL-C-25A.	Power supply filter capacitor	CP40C2FF-405K				C201, 202, 203	3
C202	Same as C201.	Power supply filter capacitor						
C203	Same as C201.	Power supply filter capacitor						
C204	CAPACITOR, fixed: paper dielectric; 0.15 uf $\pm 10\%$; 400 vdcw; characteristic 1tr F; hermetically sealed (glass to metal) tubular; wax impregnated; insulating sleeve; .400" diam x 1 1/8" lg; 2 axial wire leads.	L201 resonating capacitor			(14) XFS-1856	107-A-311	C204	1
C601	CAPACITOR, fixed: paper dielectric; 0.1 uf $\pm 20\%$ -10%; 400 vdcw; characteristic 1tr F; hermetically sealed (glass to metal) tubular; wax impregnated; insulating sleeve; .400" diam x 1 3/8" lg; 2 axial wire leads.	p/o Test lead CX-1363/U			(14) XFS-1816	107-A-295	C601	1
C602	CAPACITOR, fixed: mica dielectric; 510 uuf $\pm 5\%$; 500 vdcw; Spec. MIL-C-5/2.	p/o Test lead CX-1363/U	CM20B511J				C602	1

C701	CAPACITOR, fixed: mica dielectric; 200 uf ±5%; 500 vdcw; Spec. MIL-C-5/2.	p/o antenna simulator SM35/URM-25	CM20C201J				C701	1
C702	CAPACITOR, fixed: mica dielectric; 390 uuf ±5%; 500 vdcw; Spec. MIL-C-5/2.	p/o antenna simulator SM35/URM-25	CM20C391J				C702	1
Crystal Units								
CR101	CRYSTAL UNIT, rectifying: germanium; Spec. MIL-E-1/142D.	Audio voltage rectifier	IN69A				CR101, 102	2
CR102	Same as CR101.	Audio voltage rectifier						
Panel Knobs and Miscellaneous Electrical Accessories								
E101	SHIELD, electron tube: copper, nickel pl; cylindrical; open top; twist lock mid to socket saddle; 1 3/4" lg x .810" diam x .930" diam of flange piece; w/compression spring; JAN-S-28A.	Tube shield for V101	TS102U02				E101, 102, 105, 107	4
E102	Same as E101.	Tube shield for V102						
E103	Not used.							
E104	SHIELD, electron tube: copper, nickel pl; cylindrical; open top; twist lock mid to socket saddle; 1 3/4" lg x .810" diam x .930" diam of flange piece; w/compression spring; JAN-S-28A.	Tube shield for V104	TS102U01				E104	1
E105	Same as E101.	Tube shield for V105						
E106	SHIELD, electron tube: copper, nickel pl; cylindrical; open top; twist lock mid to socket saddle; 1 3/4" lg x .950" diam x 1.065" diam of flange piece; w/compression spring; JAN-S-28A.	Tube shield for V106	TS103U02				E106	1
E107	Same as E101.	Tube shield for V107						
E108	SHIELD, electron tube: copper, nickel pl; cylindrical; open top; twist lock mid to socket saddle; 2 1/4" lg x .810" diam x .930" diam of flange piece; w/compression spring; JAN-S-28A.	Tube shield for V108	TS102U03				E108, 201	2
E109	CAP: for BNC connectors; brass silver pl; round; approx 3/8" lg x 3/8" diam; twist lock mtg; approx 2" lg chain for securing to panel; Navy Dwg REA49050.	Protective cap for J101	Army-Navy Type CW123 A/U				E109, 110 111	3
E110	Same as E109.	Protective cap for J102						

TABLE 7-4. COMBINED PARTS AND SPARE PARTS LIST (Continued)

PARTS								
SYMBOL DESIG.	NAME OF PART AND DESCRIPTION	FUNCTION	JAN. AND (NAVY TYPE) NO.	STANDARD NAVY AND (SIGNAL CORP.) STOCK NO.	MFR. & MFR'S NATION	CON- TRACTOR DRAWING PART NO.	ALL SYMBOL DESIG. INVOLVED	QUAN. PER FOUR
Panel Knobs and Miscellaneous Electrical Accessories (cont)								
E111	Same as E109.	Protective cap for J105						
E112	COVER, self-closing; brass; gray enamel finish; high-torque coil spring; neoprene inside cap; 2 mig holes in base on 1 1/2" mig/c; 1 1/2" lg x 3/8" wd x 3/4" high o/a; 3/16" diam hole in base.	Protects Carrier-Meter-Zero control			(5) A-23405	100-A-139	E112	1
E113	KNOB, slant arrow; black molded phenolic, white arrow; 1 1/4" lg; 3/4" wd, 1/8" high o/a; 1/4" shaft hole w/brass bush; two No. 8-32 set screw holes w/hex socket screws; per Air Force Dwg. 47A40527.	Carrier range switch (S101) knob	Air Force Dwg. 47A40527				E113, 114, 115, 116, 117, 118	6
E114	Same as E113.	Carrier control (R172) knob						
E115	Same as E113.	Audio output control (R165) knob						
E116	Same as E113.	Microvolts control (R199) knob						
E117	Same as E113.	Mod, Xtal & Meter Selector (S102) knob						
E118	Same as E113.	RF Multiplier (step attenuator) knob						
E119	KNOB: black molded phenolic; round w/pointer, bar and skirt.	Frequency band switch knob			(25) 107-B-727	107-B-727	E119	1
E120	POST, binding: screw type; 3/8" diam x 1 1/8" lg FMS; one No. 10-32 x 1" lg mig stud threaded 3/8"; black bakelite cap; hole for No. 12 wire thru center shaft; captive nut type cap w/3/8" diam x 3/8" deep hole for banana plug.	Front panel ground post			(22) Type DF30BC	107-A-409	E120	1
E121	LAMP, incandescent; 3v; 190 ma; bulb T-1-1/2 clear; 3/4" lg o/a; special screw base; C-2R tungsten filament; burn any position.	Illuminates frequency scale	AN3136-523				E121, 122	2
E122	Same as E121.	Illuminates frequency scale						
E201	Same as E108.	Tube shield for V201						

Fuses				Hardware				Lamp				Connectors (Jacks and Receptacles)					
F101	FUSE, cartridge: 1 amp; open in one hr at 135% load; rated continuous at 100% load; 250V; one time; glass body; ferrule term.; 1 1/2" lg x 1/2" diam o/a; term. 3/8" lg x 1/4" diam; slow blowing; MIL-F-15166C; MS90078.	Line fuse	F02G1R00B				F101, 102, 103, 104										4
F102	Same as F101.	Line fuse															
F103	Same as F101.	Spare fuse															
F104	Same as F101.	Spare fuse															
H101	SCREW, captive; stainless steel; 3/8" lg o/a; slotted head 3/8" diam x 1/4" thk; No. 10-24 NC-2 thread 1/4" lg; 1/4" diam unthreaded part.	Secures signal generator SG85/URM-25D to case		(25) 107-A-214	107-A-214		H101										12
I 101	LAMP, neon; 105-125V; 1/25W; bulb T-3, 1/2, clear; min bay s.c.; burn any position.	Power On-Off indicator	(VO-16)				I 101	GENE-51	107-A-686								1
J101	CONNECTOR, receptacle: BNC; Navy Dwg REB49073.	RF Output X200K, Open Circuit receptacle	UG-290A/U				J101, 105										2
J102	CONNECTOR, receptacle: 1 round coaxial female contact; straight.	P/o Step attenuator AT101					J102										1
J103	CONNECTOR, receptacle: 1 round coaxial female contact; straight; MSS5179 (SIG C).	Connector for step attenuator AT101	UG-1094/U				J103, 301, 302, 401, 402, 501, 502, 601, 701, 702										10
J104	Ref Desig Cancelled.																
J105	Same as J101.	Ext Mod In-Audio Out-Xtal Cal Out receptacle															
J201	CONNECTOR, receptacle: two flat polarized blades; 3/8" diam x 1/2" high incl contacts and term.; 750V RMS; 10 amp; cylindrical black bakelite body; flange type metal mtg bracket w/two .152" diam mtg holes, on 3/8" mtg/C; 2 solder lug term.	AC input receptacle on power supply sub-chassis		(17) P-502-AB	107-A-312		J201										1

TABLE 7-4. COMBINED PARTS AND SPARE PARTS LIST (Continued)

PARTS								
SYMBOL DESIG.	NAME OF PART AND DESCRIPTION	FUNCTION	JAN. AND (NAVY TYPE) NO.	STANDARD NAVY AND (SIGNAL CORP.) STOCK NO.	MFR. & MFR.'S DESIG- NATION	CON- TRACTOR DRAWING PART NO.	ALL SYMBOL DESIG. INVOLVED	QUAN- TITY PER EQUIP.
Connectors (Jacks and Receptacles) (cont)								
J202	CONNECTOR, receptacle: 6 rectangular polarized female contacts, straight; 1" lg x 1/16" wd x 1/2" high excl term., rectangular black bakelite body; flange type metal mtg bracket w/two 0.152" diam holes on 1" mtg/C; solder lug term.	Power supply output			(17) S-306-AB	107-A-313	J202	1
J301	Same as J103.	Connector for (5:1) fixed attenuator CN-223/URM-25D						
J302	Same as J103.	Connector for (5:1) fixed attenuator CN-223/URM-25D						
J401	Same as J103.	Connector for (10:1) fixed attenuator CN-224/URM-25D						
J402	Same as J103.	Connector for (10:1) fixed attenuator CN-224/URM-25D						
J501	Same as J103.	Connector for impedance adaptor MX-1487/URM-25D						
J502	Same as J103.	Connector for impedance adaptor MX-1487/URM-25D						
J601	Same as J103.	Connector for test lead CX-1363/U						
J701	Same as J103.	antenna simulator SM-35/URM-25						
J702	Same as J103.	antenna simulator SM-35/URM-25						
Inductors								
L101	COIL, RF: oscillator; single winding; 2 pie universal wound; tapped; 1/4" max diam x 1 1/2" lg excl mtg bshg; 511.5 mh; ceramic form; adjustable powdered iron core; screw driver adjustment at bottom of coil; 1/2"-.28 x 3/8" lg mtg bshg; silicone-fibreglass collars w/one term. on top and two term. on bottom; impregnated.	Band A oscillator coil			(25) 107-B-632	107-B-632	L101	1
					N16-C-76858-2975			

L102	COIL, RF: oscillator; single winding; 1 pie universal wound; tapped; 1/4" max diam x 1 1/2" lg excl mtg bshg; 56.2 mh; ceramic form; adjustable powdered iron core; screw driver adjustment at bottom of coil; 1/4"-28 x 3/8" lg mtg bshg; silicone-fibreglass collars w/one term. on top and two term. on bottom; impregnated.	Band B oscillator coil	(25) 107-B-633	107-B-633	L102	1
L103	COIL, RF: oscillator; single winding; 1 pie universal wound; tapped; 3/16" max diam x 1 1/2" lg excl mtg bshg; 5.7 mh; ceramic form; adjustable powdered iron core; screwdriver adjustment at bottom of coil; 1/4"-28 x 3/8" lg bshg; silicone-fibreglass collars w/one term. on top and two term. on bottom; impregnated.	Band C oscillator coil	(25) 107-B-634	107-B-634	L103	1
L104	COIL, RF: oscillator; single winding, 1 pie universal wound; tapped; 3/16" max diam x 1 1/2" lg excl mtg bshg; 57.4 mh; ceramic form adjustable powdered iron core; screwdriver adjustment at bottom of coil; 1/4"-28 x 3/8" lg mtg bushing; silicone-fibreglass collars w/one term. on top and two term. on bottom; impregnated.	Band D oscillator coil	(25) 107-B-635	107-B-635	L104	1
L105	COIL, RF: oscillator; single winding; 1 pie universal wound; tapped; 3/16" max diam x 1 1/2" lg excl mtg bshg; 57.1 uh; ceramic form; adjustable powdered iron core; screwdriver adjustment at bottom of coil; 1/4"-28 x 3/8" lg mtg bushing; silicone-fibreglass collars w/one term. on top and one term. on bottom; impregnated.	Band E oscillator coil	(25) 107-B-636	107-B-636	L105	1
L106	COIL, RF: oscillator; single winding; single layer wound; tapped; 3/16" max diam x 1 1/2" lg excl mtg bshg; 5.79 uh; ceramic form; adjustable powdered iron core; screwdriver adjustment at bottom of coil; 1/4"-28 x 3/8" lg mtg bshg; silicone-fibreglass collars w/one term. on top and two term. on bottom; impregnated.	Band F oscillator coil	(25) 107-B-637	107-B-637	L106	1
L107	COIL, RF: oscillator; single winding; single layer wound; tapped; 3/16" max diam x 1 1/2" lg excl mtg bshg; .576 uh; ceramic form; adjustable powdered iron core; screwdriver adjustment at bottom of coil; 1/4"-28 x 3/8" lg mtg bshg; silicone-fibreglass collars w/one term. on top and one term. on bottom; impregnated.	Band G oscillator coil	(25) 107-B-638	107-B-638	L107	1
L108	COIL, RF: oscillator; single winding; single layer wound; tapped; 3/16" max. diam x 1 1/2" lg excl mtg bshg; .21 uh; ceramic form; adjustable powdered iron core; screwdriver adjustment on bottom of coil; 1/4"-28 x 3/8" lg mtg bshg; silicone-fibreglass collars w/one term. on top and one term. on bottom; impregnated.	Band H oscillator coil	(25) 107-B-639	107-B-639	L108	1
L109	COIL, RF: choke; single winding; 4 pie; universal wound; 2.5 mh; ±5%; 1" lg x 3/8" max diam; solid phenolic form; two 1/2" lg axial wire leads.	V101, B+ RF filter choke	(25) 107-B-643	107-B-643	L109, 116, 121	3
L110	COIL, RF: choke, single winding; single layer wound; 3 uh; molded coil form with powdered iron core section; 3/8" lg x .280" diam; two 1/2" lg axial wire leads.	V101 heater RF filter coil	(25) 107-B-645-2	107-B-645-2	L110, 120	2

TABLE 7-A. COMBINED PARTS AND SPARE PARTS LIST (Continued)

PARTS									
SYMBOL DESIG.	NAME OF PART AND DESCRIPTION	FUNCTION	JAN. AND (NAVY TYPE) NO.	STANDARD NAVY AND (SIGNAL CORP.) STOCK NO.	MFG. & MFG.'S DESIG. NATION	CON-TRACTOR DRAWING PART NO.	ALL SYMBOL DESIG. INVOLVED	QUAN. PER EQUIP.	
Inductors (cont)									
L111	COIL, RF: choke; single winding; single layer wound; 2.0 uh $\pm 10\%$; 1.7 ohms $\pm 20\%$ dc resistance; 300 ma; insulated; molded mica-filled phenolic compound; $\frac{1}{4}$ " diam x $\frac{3}{8}$ " lg; two $1\frac{1}{2}$ " axial wire leads.	V102 coupling network coil			(16) Type CLA	100-B-130-9	L111, 112	2	
L112	Same as L111.	V102 coupling network coil							
L113	COIL, RF: choke; single winding; single layer wound; .68 uh $\pm 15\%$; .44 ohms $\pm 30\%$ dc resistance; 600 ma; insulated; molded mica-filled phenolic compound; $\frac{1}{4}$ " diam x $\frac{3}{8}$ " lg; two $1\frac{1}{2}$ " lg axial wire leads.	V102 coupling network coil			(16) Type CLA	100-B-130-3	L113	1	
L114	COIL, RF: choke; single winding; single layer wound; 1.5 uh $\pm 10\%$; 1.2 ohms $\pm 20\%$ dc resistance; 350 ma; insulated; molded mica-filled phenolic compound; $\frac{1}{4}$ " diam x $\frac{3}{8}$ " lg; two $1\frac{1}{2}$ " lg axial wire leads.	V103 coupling network coil			(16) Type CLA	100-B-130-7	L114	1	
L115	COIL, RF: choke; single winding; single layer wound; 1.2 uh $\pm 10\%$; .85 ohms $\pm 20\%$ dc resistance; 400 ma; insulated; molded mica-filled phenolic compound; $\frac{1}{4}$ " diam x $\frac{3}{8}$ " lg; two axial wire leads.	V103 coupling network coil			(16) Type CLA	100-B-130-6	L115	1	
L116	Same as L109.	V103 plate choke							
L117	COIL, RF: choke; single winding; 3 pie universal wound; 11.5mh, $\pm 5\%$; $\frac{1}{4}$ " diam x 1" lg; powdered iron core; with brass insert for mounting; two collars with term.	V103 plate choke			(25) 107-B-642	107-B-642	L117, 118	2	
L118	Same as L117.	V103 plate choke							
L119	COIL, RF: choke; single winding; 2 pie universal wound; 100 uh; $\pm 5\%$; $\frac{3}{8}$ " diam x $\frac{3}{8}$ " lg; solid phenolic form; two axial wire leads.	V102 and V103 B+ RF filter coil			(25) 107-B-644	107-B-644	L119, 124	2	
L120	Same as L110.	V102, V103 and V104 heater RF filter coil							
L121	Same as L109.	V105 cathode RF choke							
L122	COIL, RF: choke; single winding; single layer wound; 7.0 uh; $\pm 10\%$; .95 ohms $\pm 10\%$ dc resistance; 1 amp; $\frac{3}{8}$ " diam x 1" lg; phenolic core; two axial wire leads.	Line filter choke			(19) Z-50	107-A-422	L122, 123	2	
L123	Same as L122.	Line filter choke							
L124	Same as L119.	J105 RF filter choke							

L201	CHOKE, filter: 11 h $\pm 10\%$; 75 ma; 400 ohms max dc resistance; 750V RMS test; hermetically sealed metal case; 1 1/2" lg x 1 1/4" wd x 2 1/2" high excl term; four No. 6-32 x 3/8" lg mtg studs on 1 1/2" x 1 1/2" mtg/c; two solder lug term. on bottom of case; Spec. MIL-T-27.	Power supply filter	(25) 107-B-310	107-B-310	L201	1
L701	COIL, RF: single winding; single layer wound; 20 uh; $\pm 10\%$; .280" diam x 1/4" lg; powdered iron core form; two axial wire leads.	p/o antenna simulator SM-35/URM-25	(25) 107-B-645-1	107-B-645-1	L701	1
Meters						
M101	METER, multiskale: DC; range 0 to 100 micro-amps; hermetically sealed round metal flush mtg case; type MR26W per Spec. MIL-M-6B.	RF Output and percent modulation meter		107-B-670 and 107-A-9	M101	1
Scales						
N101	SCALE, vernier: for interpolating frequency tuning dial; arc shape; aluminum; 90° lg on 1 1/4" outside radius and .885" inside radius; .101" thick; ten scale divisions; two .128" diam mtg holes spaced 66° apart on 1.031" radius.	Vernier for tuning dial (N102)	(25) 107-B-124B	107-B-124B	N101	1
N102	DIAL, frequency tuning; etched aluminum dial plate and bakelite knob; round 1 1/2" diam dial plate .0319" thk; 1 1/2" diam knob; brass insert for 1/4" diam shaft; two No. 8-32 set screws; dial plate marked in 100 equally spaced divisions.	Main tuning	(25) 107-B-671	107-B-671	N102	1
N103	DIAL, frequency scale: round; .064" thk brass; 280 teeth, 48 DP, on 5.832" PD; 1.125" diam hole in center; backlash spring pin .125" diam projecting .093" from back of dial 2 3/4" from center; eight scales covering 180° each in two groups of four, top group in kilocycles, bottom group in megacycles; additional scale marked 0 to 1000 covering 180° on bottom section.	Frequency scale	(25) 107-B-652	107-B-652	N103	1
N104	INDEX, frequency scale: .093" thk transparent plastic per JAN-P-15; 2 3/4" wd x 6 1/4" lg; 1 1/4" diam hole in center; four .166" diam holes on 2.375" x 5.875" mtg/c; .005" wide black hairline on long axis on both sides.	Frequency scale index	(25) 107-B-566	107-B-566	N104	1
N105	WINDOW, frequency scale: .051" thk transparent plastic per JAN-P-15; 1 1/2" wd x 2 3/4" lg; four .099" diam holes on 1.312" x 1.750" and 2.00" mtg/c.	Window for frequency scale	(25) 107-A-174	107-A-174	N105, 106	2
N106	Same as N105.	Window for frequency scale				

TABLE 7-4. COMBINED PARTS AND SPARE PARTS LIST (Continued)

PARTS								
SYMBOL DESIG.	NAME OF PART AND DESCRIPTION	FUNCTION	JAN. AND (NAVY TYPE) NO.	STANDARD NAVY AND (SIGNAL CORP.) STOCK NO.	MFR. & MFR.'S DESIG- NATION	CON- TRACTOR DRAWING PART NO.	ALL SYMBOL DESIG. INVOLVED	QUAN- TITY PER EQUIP.
Mechanical Parts								
O 101	GEAR, frequency scale; round; .064" thk brass; 280 teeth; 48 DP on 5.832" PD 60° sector cut to 2" radius; 6 holes 1" diam spaced equally on 1 1/4" rad and 5 holes 1" diam on 2 3/4" rad; one .687" diam mtg hole in center; three .062" diam mtg holes equally spaced on .468" radius.	Anti-backlash gear for frequency scale dial			(25) 107-B-564	107-B-564	O 101	1
O 102	HUB, frequency scale dial and gear; stainless steel; 1 3/4" diam x .215" thk o/a; machine to fit gear O 101 and dial N103; .375" diam hole in center; three .078" diam csk holes equally spaced on .937" diam.	Frequency scale dial and gear hub			(25) 107-B-565	107-B-565	O 102	1
O 103	MASK, dial; assembly for masking and uncovering ranges on frequency scale; No. .18 gauge aluminum with black enamel finish; 5 3/8" diam; brass hub in center 1 1/4" diam x .312" thick o/a; w/.250" diam hole in center and two No. 6-32 NC-2 holes tapped 90° apart for setscrew; four 1/4" wide slots covering 24°, spaced 45° apart on 1 3/8", 1 3/8", 2 3/8" and 2 3/8" rad.	Frequency scale mask			(25) 107-C-666	107-C-666	O 103	1
O 104	SPRING, detent; steel, heat treated to spring temper; .041" thk; 2 3/8" lg x 3/8" wide o/a; 1 3/8" of length .390" wide and curved to 2.562" rad; retainer for roller at one end; two slots on 3/8" mtg/c.	p/o turret detent			(25) 107-A-509	107-A-509	O 104	1
O 105	ROLLER, detent; stainless steel; .375" diam x .375" lg; .093" diam x 1/8" lg axle at each end.	p/o turret detent			(25) 107-A-508	107-A-508	O 105	1
O 106	CLAMP, crystal; .010" thk beryllium copper, heat treated; 3/8" wide x 7/8" high x 1/8" deep o/a; two bends; two .128" diam holes on 3/8" mtg/c.	Retains crystal Y101 in socket XY101			(25) 107-B-274	107-B-274	O 106	1
Connectors, Plugs								
P101	CONNECTOR, plug; 2 rectangular female polarized contacts; straight type; 7/8" diam x 1/8" lg excl cable clamp; 730V rms; 10 amp; cylindrical crystal finish metal body; molded black bakelite insert; cable opening 3/8" diam max; includes adjustable grip cable clamp.	p/o interconnecting AC power cable (W102)			(17) S-302-CCT	107-A-684	P101	1
P102	CONNECTOR, plug; 6 flat polarized blades; straight type; 1" lg x 1/8" wd x 1 1/8" deep excl contacts and cable clamp; 730V; 10 amps; rectangular crystal finish metal body.	p/o power supply output power cable (W103)			(17) P-306-CCT	107-A-685	P102	1

P103	molded black bakelite insert; cable opening $\frac{3}{16}$ " diam max; incl adjustable grip cable clamp. CONNECTOR, plug: BNC; Navy Dwg REB49064.	UG-88C/U			P103, 104, 105, 106, 107, 108, 109	1
P104	Same as P103.					
P105	Same as P103.					
P106	Same as P103.					
P107	Same as P103.					
P108	Same as P103.					
P109	Same as P103.					
P110	CONNECTOR, plug: 3 male contacts; MIL-C-3767; MS91185.	UP121M			P110	1
P801	CONNECTOR, adaptor: coax male type N at one end, coax female type BNC other end; straight type; adapts female type N to male type BNC connector; Navy Dwg REB49324.	UG-201A/U			P801	1
Resistors						
R101-1	RESISTOR, fixed: composition; 220K $\pm 10\%$; $\frac{1}{2}W$; Spec. MIL-R-11/2.	RC20GF224K		Band A, V101 grid leak resistor	R101-1	1
R102	RESISTOR, fixed: composition; 47K $\pm 10\%$; $\frac{1}{2}W$; Spec. MIL-R-11/2.	RC20GF473K		Band A, V101 cathode resistor	R102, 156, 161	3
R103-1	RESISTOR, fixed: composition; 150K $\pm 10\%$; $\frac{1}{2}W$; Spec. MIL-R-11/2.	RC20GF154K		Band B, V101 grid leak resistor	R103-1	1
R104	RESISTOR, fixed: composition; 22K $\pm 10\%$; $\frac{1}{2}W$; Spec. MIL-R-11/2.	RC20GF223K		Band B, V101 cathode resistor	R104, 111, 150, 168	4
R105-1	RESISTOR, fixed: composition; 33K $\pm 10\%$; $\frac{1}{2}W$; Spec. MIL-R-11/2.	RC20GF333K		Band C, V101 grid leak resistor	R105-1, 117	2

TABLE 7-4. COMBINED PARTS AND SPARE PARTS LIST (Continued)

PARTS								
SYMBOL DESIG.	NAME OF PART AND DESCRIPTION	FUNCTION	JAN. AND (NAVY TYPE) NO.	STANDARD NAVY AND (SIGNAL CORP.) STOCK NO.	MFR. & MFR'S DESIG. NATION	CON- TRACTOR DRAWING PART NO.	ALL SYMBOL DESIG. INVOLVED	QUAN. PER EQUIP.
Resistors (cont)								
R106	RESISTOR, fixed: composition; 18K \pm 10%; 1/2W; Spec. MIL-R-11/2.	Band C, V101 cathode resistor	RC20GF183K				R106	1
R107-1	RESISTOR, fixed: composition; 10K \pm 10%; 1/2W; Spec. MIL-R-11/2.	Band D, V101 grid leak resistor	RC20GF103K				R107-1, 112	2
R108	RESISTOR, fixed: composition; 6800 ohms \pm 10%; 1/2W; Spec. MIL-R-11/2.	Band D, V101 cathode resistor	RC20GF682K				R108	1
R109-1	RESISTOR, fixed: composition; 2200 ohms \pm 10%; 1/2W; Spec. MIL-R-11/2.	Band E, V101 grid leak resistor	RC20GF222K				R109-1, 110-1, 116, 149	4
R110-1	Same as R109-1.	Band E, V101 cathode resistor						1
R111	Same as R104.	Band F, V101 grid leak resistor						
R112	Same as R107-1.	Band G, V101 grid leak resistor						
R113	RESISTOR, fixed: composition; 4700 ohms \pm 10%; 1/2W; Spec. MIL-R-11/2.	Band H, V101 grid leak resistor	RC20GF472K				R113, 144	2
R114	RESISTOR, fixed: composition; 100K \pm 10%; 1/2W; Spec. MIL-R-11/2.	V102 grid resistor	RC20GF104K				R114, 146, 160, 164	4
R115	RESISTOR, fixed: composition; 160 ohm \pm 5%; 1/2W; Spec. MIL-R-11/2.	V102 cathode resistor	RC20GF161J				R115	1
R116	Same as R109-1.	L111 damping resistor						

R117	Same as R105-1.	V102 screen grid resistor	RC20GF471J	R118	1
R118	RESISTOR, fixed: composition; 470 ohms $\pm 5\%$; $\frac{1}{2}W$; Spec. MIL-R-11/2.	V102 plate resistor	RV2NAXSG-502A	R119	1
R119	RESISTOR, variable: composition; 5000 ohms $\pm 10\%$; taper A; $1W$; Spec. MIL-R-94B.	Microvolts control	RC20GF511J	R120	1
R120	RESISTOR, fixed: composition; 510 ohms $\pm 5\%$; $\frac{1}{2}W$; Spec. MIL-R-11/2.	L113 damping resistor	RC20GF513J	R121	1
R121	RESISTOR, fixed: composition; 51K $\pm 5\%$; $\frac{1}{2}W$; Spec. MIL-R-11/2.	p/o V103 grid resistor	RC20GF103J	R122, 128, 142	3
R122	RESISTOR, fixed: composition; 10K $\pm 5\%$; $\frac{1}{2}W$; Spec. MIL-R-11/2.	p/o V103 grid resistor	RC20GF271J	R123	1
R123	RESISTOR, fixed: composition; 270 ohms $\pm 5\%$; $\frac{1}{2}W$; Spec. MIL-R-11/2.	V103 cathode resistor	RC20GF152K	R124	1
R124	RESISTOR, fixed: composition; 1500 ohms $\pm 10\%$; $\frac{1}{2}W$; Spec. MIL-R-11/2.	L115 damping resistor	RC20GF474K	R125, 151, 166	3
R125	RESISTOR, fixed: composition; 470K $\pm 10\%$; Spec. MIL-R-11/2.	p/o V104 biasing system	RC20GF153J	R126, 170, 171	3
R126	RESISTOR, fixed: composition; 15K $\pm 5\%$; $\frac{1}{2}W$; Spec. MIL-R-11/2.	p/o V104 biasing system	RV2NAXSB-102A	R127	1
R127	RESISTOR, variable: composition; 1K $\pm 10\%$; $2W$; taper A; Spec. MIL-R-94B.	Carrier meter zero control			

TABLE 7-4. COMBINED PARTS AND SPARE PARTS LIST (Continued)

PARTS		PARTS						
SYMBOL DESIG.	NAME OF PART AND DESCRIPTION	FUNCTION	JAN. AND (NAVY TYPE) NO.	STANDARD NAVY AND (SIGNAL CORP.) STOCK NO.	MFGR. & MFGR'S DESIG- NATION	CON- TRACTOR DRAWING PART NO.	ALL SYMBOL DESIG. INVOLVED	QUAN PER EQUIP.
Resistors (cont)								
R128	Same as R122.	p/o V104 load resistor	RC20GF101K				R129, 177	2
R129	RESISTOR, fixed: composition; 100 ohms $\pm 10\%$; $\frac{1}{2}W$; Spec. MIL-R-11/2.	J101 separating resistor						
R130	RESISTOR, fixed: film; 499 ohms $\pm 1\%$; $\frac{1}{2}W$; Spec. MIL-R-10509B.	p/o attenuating system	RN70B4990F				R130	1
R131	RESISTOR, fixed: deposited carbon; 61.8 ohms $\pm 1\%$; $\frac{1}{4}W$; 250 max rv; insulated; neg temp. coeff; $\frac{3}{16}$ " diam x $\frac{1}{8}$ " lg; 2 axial wire leads.	p/o step attenuator			(9) DC 1/8	107-A- 708-14	R131	1
R132	RESISTOR, fixed: deposited carbon; 495 ohms $\pm 1\%$; $\frac{1}{4}W$; 250 max rv; insulated; neg temp. coeff; $\frac{3}{16}$ " diam x $\frac{1}{8}$ " lg; 2 axial wire leads.	p/o step attenuator			(9) DC 1/8	107-A- 708-12	R132, 134, 136, 138, 140	5
R133	RESISTOR, fixed: deposited carbon; 61.1 ohms $\pm 1\%$; $\frac{1}{4}W$; 250 max rv; insulated; neg temp. coeff; $\frac{3}{16}$ " diam x $\frac{1}{8}$ " lg; 2 axial wire leads.	p/o step attenuator			(9) DC 1/8	107-A- 708-13	R133, 135, 137, 139	4
R134	Same as R132.	p/o step attenuator						
R135	Same as R133.	p/o step attenuator						
R136	Same as R132.	p/o step attenuator						
R137	Same as R133.	p/o step attenuator						
R138	Same as R132.	p/o step attenuator						
R139	Same as R133.	p/o step attenuator						
R140	Same as R132.	p/o step attenuator						
R141	RESISTOR, fixed: deposited carbon; 55.0 ohms $\pm 1\%$; $\frac{1}{4}W$; 250 max rv; insulated; neg temp coeff; $\frac{3}{16}$ " diam x $\frac{1}{8}$ " lg; 2 axial wire leads.	p/o step attenuator			(9) DC 1/8	107-A- 708-11	R141	1
R142	Same as R122.	Modulation input RF filter resistor						
R143	RESISTOR, fixed: composition; 270 ohms $\pm 10\%$; $\frac{1}{2}W$; Spec. MIL-R-11/2.	V103 screen voltage RF filter resistor	RC20GF271K				R143	1

R144	Same as R113.									
R145	RESISTOR, fixed: composition; 27K $\pm 10\%$; $1/2W$; Spec. MIL-R-11/2.	V104 output RF filter resistor	RC20GF273K	R145	1					
R146	Same as R114.	V105 screen grid resistor								
R147	RESISTOR, fixed: composition; 270K $\pm 10\%$; $1/2W$; Spec. MIL-R-11/2.	V105 plate resistor	RC20GF274K	R147, 148	2					
R148	Same as R147.	V105 first grid resistor								
R149	Same as R109-1.	V105 third grid resistor								
R150	Same as R104.	V105 B+ RF filter resistor								
R151	Same as R125.	V105 output RF filter resistor								
R152	RESISTOR, fixed: film; 392K $\pm 1\%$; $1/2W$; Spec. MIL-R-10509B.	V106 grid resistor	RN70B3923F	R152, 123	2					
R153	Same as R152.	V106 400 cps bridge resistor								
R154	RESISTOR, fixed: film; 154K $\pm 1\%$; $1/2W$; Spec. MIL-R-10509B.	V106 400 cps bridge resistor	RN70B1543F	R154, 155	2					
R155	Same as R154.	V106 1000 cps bridge resistor								
R156	Same as R102.	V106 1000 cps bridge resistor								
R157	RESISTOR, variable: composition; 25000 ohms $\pm 10\%$; 2W; continuously adjustable; no switch; Spec. MIL-R-94B.	V106 degeneration resistor	RV4LAXSA-253A	R157	1					
R158	RESISTOR, fixed: composition; 1000 ohms $\pm 10\%$; $1/2W$; Spec. MIL-R-11/2.	V106 degeneration control								
R159	RESISTOR, fixed: composition; 20K $\pm 5\%$; $1/2W$; Spec. MIL-R-11/2.	p/o V106 cathode resistor	RC20GF102K	R158, 162, 167	3					
R160	Same as R114.	p/o V106 cathode resistor	RC20GF203J	R159	1					
		V106 plate resistor								

TABLE 7-4. COMBINED PARTS AND SPARE PARTS LIST (Continued)

PARTS								
SYMBOL DESIG.	NAME OF PART AND DESCRIPTION	FUNCTION	JAN. AND (NAVY TYPE) NO.	STANDARD NAVY AND (SIGNAL CORP.) STOCK NO.	MFR. & MFR'S DESIG- NATION	CON- TRACTOR DRAWING PART NO.	ALL SYMBOL DESIG INVOLVED	QUAN- TITY PER EQUIP
Resistors (cont)								
R161	Same as R102.	V106 plate resistor						
R162	Same as R158.	V106 cathode resistor						
R163	RESISTOR, fixed: composition: 1 megohm $\pm 10\%$; $\frac{1}{2}$ W; Spec. MIL-R-11/2.	V106 grid resistor	RC20GF105K				R163	1
R164	Same as R114.	p/o V106 output divider						
R165	RESISTOR, variable: composition: 50K $\pm 10\%$; 2W; no switch; Spec. MIL-R-94B.	p/o Mod, Audio Out, Xtal Cal Out control	RV4NAXSD-503A				R165	1
R166	Same as R125.	V107 grid resistor						
R167	Same as R158.	V107 biasing resistor						
R168	Same as R104.	V107 cathode resistor						
R169	RESISTOR, variable: composition: 2500 ohms $\pm 10\%$; 2W; continuously adjustable; no switch; Spec. MIL-R-94B.	Modulation metering sensitivity control	RV4LAXSA-252A		(1) JLU 2521	107-A-341	R169, 172	2
R170	Same as R126.	p/o modulation metering system						
R171	Same as R126.	p/o modulation metering system						
R172	Same as R169.	Carrier metering sensitivity control						
R173	RESISTOR, variable: wire wound, 50000 ohms $\pm 10\%$; 4W; 40°C max continuous operating temp.; 3 solder lug term; encl bakelite case w/metal cover; $1\frac{1}{32}$ " diam x $\frac{3}{16}$ " lg; $\frac{1}{4}$ " diam rd shaft $\frac{1}{8}$ " lg; JAN A taper; no switch; normal torque, mig bshg $\frac{3}{8}$ "-32 thd x $\frac{1}{4}$ " lg.; JAN-R-19.	Set carrier control	RA30A1RD-503AK				R173	1
R174	RESISTOR, fixed: wire wound; 16 ohms $\pm 5\%$; 1W; Spec. JAN-R-184.	Dial light dropping resistor	RU4B160J					
R175	Same as R174.	Dial light dropping resistor					R174, 175	2

R176	RESISTOR, fixed: comp. 3.3 meg $\pm 10\%$; $\frac{1}{2}W$; Spec. MIL-R-11/2.	Xtal, Cal coupling resistor	RC20CF335K	R176	1
R177	Same as R129.	V107 series grid resistor			
R201	RESISTOR, fixed: wire wound; 3100 ohms $\pm 5\%$; 22W; Spec. MIL-R-26.	Power supply series dropping resistor	RW21G312	R201	1
R301	RESISTOR, fixed: film; 75 ohms $\pm 1\%$; $\frac{1}{2}W$; Spec. MIL-R-10509B.	p/o 5:1 fixed attenuator CN-223/URM-25D	RN70B75R0F	R301, 303	2
R302	RESISTOR, fixed: film; 121 ohms $\pm 1\%$; $\frac{1}{2}W$; Spec. MIL-R-10509B.	p/o 5:1 fixed attenuator CN-223/URM-25D	RN70B1210F	R302	1
R303	Same as R301.	p/o 5:1 fixed attenuator CN-223/URM-25D			
R401	RESISTOR, fixed: film; 61.9 ohms $\pm 1\%$; $\frac{1}{2}W$; Spec. MIL-R-10509B.	p/o 10:1 fixed attenuator CN-224/URM-25D	RN70B61R9F	R401, 403	2
R402	RESISTOR, fixed: film; 249 ohms $\pm 1\%$; $\frac{1}{2}W$; Spec. MIL-R-10509B.	p/o 10:1 fixed attenuator CN-224/URM-25D	RN70B2490F	R402	1
R-403	Same as R401.	p/o 10:1 fixed attenuator CN-224/URM-35D			
R501	RESISTOR, fixed: film; 49.9 ohms $\pm 1\%$; $\frac{1}{2}W$; Spec. MIL-R-10509B.	p/o impedance adapter MX-1487/URM-25D	RN70B49R9F	R501	1
R701	RESISTOR, fixed: film; 402 ohms $\pm 1\%$; $\frac{1}{2}W$; Spec. MIL-R-10509B.	p/o antenna simulator SM-35/URM-25	RN70B4020F	R701	1
Switches					
S101	SWITCH, rotary: 2 section; 4 positions; 1 pole, 6 stator contacts on 1 section; 4 stator contacts on 1 section; silver alloy contacts; ceramic body; $\frac{1}{4}$ " lg x $1\frac{1}{4}$ " wd x $1\frac{1}{4}$ " high; single hole mig bshg $\frac{3}{8}$ "-32 x $\frac{1}{4}$ " lg; $\frac{1}{4}$ " diam rd shaft $1\frac{1}{4}$ " lg; non-turn device; Spec. MIL-S-3786.	Carrier Range Switch	(18) 107-B-646	107-B-646	S101
S102	SWITCH, rotary: 4 section; 5 position; 2 poles per section on 3 sections; 2 stator contacts on 1 section; silver alloy contacts; ceramic body; $1\frac{1}{4}$ " lg x $1\frac{1}{4}$ " wd x $1\frac{1}{4}$ " high; shorting type; solder lug term; signal hole mig; bushing $\frac{3}{8}$ "-32 x $\frac{1}{4}$ " lg; $\frac{1}{4}$ " diam rd metal shaft $\frac{1}{4}$ " lg; non-turn device; Spec. MIL-S-3786.	Mod, Xtal & Meter Selector	(13) 107-B-647	107-B-647	S102

TABLE 7-4. COMBINED PARTS AND SPARE PARTS LIST (Continued)

PARTS						
SYMBOL DESIG.	NAME OF PART AND DESCRIPTION	FUNCTION	JAN. AND (NAVY TYPE) NO.	STANDARD NAVY MFG. & DESIG- NATION	CON- TRACTOR DRAWING PART NO.	ALL SYMBOL DESIG. INVOLVED
Switches (Cont)						
S103	SWITCH, toggle: DPST; 5 amps; 125v dc; phenolic body; 1 1/2" lg x 3/8" wd x 3/8" d; 1/16" lg bat type handle; normally open; solder lug term; single hole mtg bshg 1/8"-32, 1/8" lg; Spec. MIL-S-21195.	Power Off/On Switch	ST22K			S103
Transformer						
T201	TRANSFORMER, power: filament and plate type; 115V, 50/1000 cyc; single ph; two output windings, sec #1 - 6.5V at 4.5 amp; sec #2 - 450V CT at 75 ma; working voltage to ground, pri 165V - RMS test 500V, sec #1 - 10V - RMS test 500V, sec #2 - 320 V - RMS test 900V; hermetically sealed rectangular case; 3" lg x 2 1/2" wd x 3 1/2" high excd term; seven 1/2" high standoff term; four No. 8-32 x 1/2" lg mtg bolts on 2" x 2 1/4" mtg/c; Spec. MIL-T-27, Grade 1, Class A, Family 03.	Power Transformer		(25) 107-B-309	107-B-309	T201
Terminal Boards						
TB101	BOARD, terminal: resistor, capacitor, Xtal diode mounting board; 66 standoff lug term; XXX phenolic rectangular board, .093" thk; 6 1/2" lg x 4" wd; four .128" diam holes on 1.750" x 5.125" mtg/c.	Audio and metering terminal board		(25) 107-C-650	107-C-650	TB101
TB102	BOARD, terminal: 5 feed-through lug term; XXX phenolic rectangular board, .093" thk; 1 1/2" lg x 1 1/4" wd; two .104" diam holes on 2 3/8" mtg/c.	RF filters output		(25) 107-B-651	107-B-651	TB102
TB103	BOARD, terminal: resistor, capacitor, choke mounting board; 5 feed-through lug term; 4 standoff lug term; XXX phenolic board .093" thk; irregular shape; 3 1/2" lg x 2 1/4" wd o/a; two .128" diam holes on 1 1/4" mtg/c.	RF bracket terminal board assy		(25) 107-B-720	107-B-720	TB103
Electron Tubes						
V101	ELECTRON TUBE: R-F pentode; Spec. MIL-E-1.	Carrier oscillator	6AH6			V101, 102, 107
V102	Same as V101.	Buffer stage				
V103	ELECTRON TUBE: power pentode; Spec. MIL-E-1.	Output amplifier	6AG7			V103
V104	ELECTRON TUBE: double-diode Spec. MIL-E-1.	Carrier volt meter	5726/6AL5W/ 6097			V104
V105	ELECTRON TUBE: pentagrid Spec. MIL-E-1.	Crystal calibrator	5750/6BE6W			V105

Part No.	Description	Quantity	Part No.	Description	Quantity
V106	ELECTRON TUBE: double triode Spec. MIL-E-1.	1	V106		
V107	Same as V101.				
V108	ELECTRON TUBE: voltage regulator Spec. MIL-E-1.	1	V108		
V201	ELECTRON TUBE: full-wave high-vacuum rectifier Spec. MIL-E-1.	1	V201		
Sockets					
XV101	SOCKET, tube: ceramic; 7 contact miniature; Spec. JAN-S-28A.	4	TS102C01	Tube socket for V101	
XV102	Same as XV101.				
XV103	SOCKET, tube: ceramic; octal; Spec. JAN-S-28A.	1	TS101C02	Tube socket for V102	
XV104	Same as XV101.				
XV105	Same as XV101.				
XV106	SOCKET, tube: phenolic; noval; Spec. JAN-S-28A.	1	TS103P01	Tube socket for V105	
XV107	SOCKET, tube: phenolic; 7-contact miniature; Spec. JAN-S-28A.	3	TS102P01	Tube socket for V106	
XV201	Same as XV107.				
XY101	SOCKET, crystal: copper, silver pl; steatite insulation; 3/4" lg x 3/4" wd x 3/8" high excl term.	1		Tube Socket for V201	
XF101	HOLDER, fuse: extractor post type; for single 3AG cartridge fuse; black bakelite; 250W at 15 amp.	2		Socket for crystal Y101	(8) 9006
				Holder for fuse F101	(3) HKP. HRWEJ
XF102	Same as XF101.			Holder for fuse F102	
XI101	HOLDER, indicator lamp: for miniature bayonet base T-3-1/2 neon lamp; built-in resistor; clear lens; for 1/4" mg hole; molded bakelite insulation; 2 solder lug term; MIL-L-3661, MS90287.	1	LH64PC2	Holder and lens for I101	

TABLE 7-4. COMBINED PARTS AND SPARE PARTS LIST (Continued)

PARTS								
SYMBOL DESIG.	NAME OF PART AND DESCRIPTION	FUNCTION	JAN. AND (NAVY TYPE) NO.	STANDARD NAVY AND (SIGNAL CORP.) STOCK NO.	MFGR. & MFGR'S DESIG- NATION	CON- TRACTOR DRAWING PART NO.	ALL SYMBOL DESIG. INVOLVED	QUAN- TITY PER EQUIP
Crystal								
Y101	CRYSTAL UNIT, quartz: one quartz plate, nominal frequency 1mc; two .05" diam contact pins spaced 0.486" C to C on bottom; rectangular metal body 1/4" lg x 1/2" wd x 3/4" high; not adjustable; Spec. MIL-C-3098.	Crystal calibrator (V105) crystal	CR-18/U				Y101	1
Accessories								
W101-1	CABLE ASSEMBLY, power, electrical: c/o cable W108 with plug P110 at one end.	AC line cable			(25) 142-B-25	142-B-25	W101-1	1
W104	CABLE ASSEMBLY, RF: MIL type RG-58C/U cable 3 ft. 11" lg; two MIL type UG-88C/U connectors, one at each end.	RF output cable					W104	1
W105	CABLE ASSEMBLY, RF: MIL type RG-58C/U cable 5" lg; two MIL type UG-88C/U connectors, one at each end.	Accessory RF output cable			(25) 107-C-663	107-C-663	W105, 106	2
W106	Same as W105.	Accessory RF output cable						
W108	CABLE, power, electrical: type SJ; 3 conductor, stranded, No. 18AWG; rubber insulation; cotton warp; rubber jacket.	p/o W101-1					W108	6 ft.
	ATTENUATOR, fixed: pi network; input and output impedance 50 ohms; 5:1 attenuation; enclosed in rectangular aluminum case 2" lg x 1 1/4" wd x 1" high; two UG-1094/U connectors, one at each end; each marked 5:1 Fixed Attenuator CN-223/URM-25D.	5:1 fixed attenuator			(25) 107-C-662	107-C-662		1
	ATTENUATOR, fixed: pi network; input and output impedance 50 ohms; 10:1 attenuation; enclosed in rectangular aluminum case 2" lg x 1 1/4" wd x 1" high; two UG-1094/U connectors, one at each end; each marked 10:1 Fixed Attenuator CN-224/URM-25D.	10:1 fixed attenuator			(25) 107-C-664	107-C-664		1
	ADAPTER, impedance: terminating resistor 50 ohms; enclosed in rectangular aluminum case 2" lg x 1 1/4" wd x 1" high; two UG-1094/U connectors, one at each end; marked Impedance Adapter MX-1487/URM-25D.	50 ohms termination			(25) 107-D-683	107-D-683		1
	LEAD, test: one red lead MIL type MW-C20(7)U2; one black lead MIL type MW-C20(7)U0; 16" lg; each wire term at one end in Mueller type 60CS alligator clip; red lead connected in series with a parallel combination of capacitors C601 and C602; black lead grounded to case.	Output test lead						1

<p>rectangular aluminum case 2" lg x 1 1/2" wd x 1" high; one UG-1094/U connector at each end; 3/8" ID bushing at other end to permit entry of both leads; marked TEST LEAD CX-1363/U.</p>	<p>Dummy antenna</p>	<p>(25) 107-C-661</p>	<p>107-C-661</p>	<p>1</p>
<p>ANTENNA SIMULATOR: consists of inductor L701, capacitors C701 and C702 and resistor R701; enclosed in rectangular aluminum case 2" lg x 1 1/2" wd x 1" high; two UG-1094/U connectors, one at each end; marked Antenna Simulator SM-35/URM-25.</p>	<p>BNC to N adapter</p>			<p>1</p>
<p>ADAPTER, coaxial: (described under symbol P801).</p>	<p>No. 8 Allen setscrew wrench</p>			<p>1</p>
<p>WRENCH: for No. 8 Allen setscrew.</p>	<p>No. 10 Allen setscrew wrench</p>			<p>1</p>
<p>CONNECTOR, adapter: cylindrical nickel pl brass body, 1 3/8" lg x 1" diam excl connectors; one BNC connector, receptacle, type UG-1094/U at one end; one phone jack, type JJ-034 at other end; marked Connector Adapter UG-684A/U.</p>	<p>Adapter from type UG-88C/U BNC plug to phone plug type PJ-055</p>	<p>(25) 107-B-741</p>	<p>107-B-741</p>	<p>1</p>
<p>CONNECTOR, adapter: straight type; BNC type to mate with plug UG-88C/U one end; other end to mate with type 49120 receptacle; 1 1/16 in. lg; 3/4 in. od; cylindrical shaped body; brass; sil pl; molded Teflon insert.</p>	<p>Adapter from type UG-88C/U to type 49120</p>	<p>(25) 153-B-9</p>	<p>153-B-9</p>	<p>1</p>

TABLE 7-5. LIST OF MANUFACTURERS

ABBREVIATIONS	PREFIX	NAME	ADDRESS
1	CBZ	Allen-Bradley Co.	Milwaukee, Wis.
2	CQG	Belden Mfg. Co.	Chicago, Ill.
3	CFA	Bussman Mfg. Co.	St. Louis, Mo.
4	CMC	Clarostat Mfg. Co.	Brooklyn, N. Y.
5		Croname Inc.	Chicago, Ill.
6	CAE	Cutler-Hammer, Inc.	Milwaukee, Wis.
7	DLC	Dial Light Co.	New York, N. Y.
8	CEB	Eby, Hugh, Inc.	Philadelphia, Pa.
9		Electra Mfg. Co.	Kansas City, Mo.
10	CER	Erie Resistor Co.	Erie, Pa.
11	GE	General Electric Co.	Cleveland, O.
12	GRA	General Radio	Cambridge, Mass.
13		Grigsby-Allison	Arlington Heights, Ill.
14	CCF	Gudeman Co.	Chicago, Ill.
15		Herzog Miniature Lamp Works	New York, New York
16	CIR	International Resistance Corp.	Philadelphia, Pa.
17	CJC	Jones, Howard B.	Chicago, Ill.
18	COC	Oak Mfg. Co.	Chicago, Ill.
19	COM	Ohmite Mfg. Co.	Chicago, Ill.
20	CRK	Radio Condenser Co.	Camden, N. J.
21	CSF	Sprague Specialties Co.	N. Adams, Mass.
22	CABU	Superior Electric Co.	Bristol, Conn.
23	CHS	Sylvania Electric Products Inc.	Emporium, Pa.
24		Texas Instrument Co.	Dallas, Texas
25		Trad Electronics Corp.	Asbury Park, N. J.
26		Malco Tool and Mfg. Co.	Chicago, Ill.

TABLE 7-6. APPLICABLE COLOR CODES AND MISCELLANEOUS DATA

RESISTORS		CAPACITORS						
TOLERANCE	MULTIPLIER	SIGNIFICANT FIGURE	COLOR	RMA MIC 3 AND CERAMIC DIELECTRIC	JAN MIC 3 AND AMPER-DIELECTRIC	JAN CERAMIC DIELECTRIC	VOLTAGE RATING	TEMPERATURE COEFFICIENT
	1	0	BLACK	1	1	1	A	
	10	1	BROWN	10	10	10	100	B
	100	2	RED	100	100	100	200	C
	1000	3	ORANGE	1000	1000	1000	300	D
	10000	4	YELLOW	10000	10000	10000	400	E
	100000	5	GREEN	100000	100000		500	F
	1000000	6	BLUE	1000000			600	G
	10000000	7	VIOLET	10000000			700	
	100000000	8	GRAY	100000000		0.01	800	
	1000000000	9	WHITE	1000000000		0.1	900	
5	0.1		GOLD	0.1	0.1		1000	
10	0.01		SILVER	0.01	0.01		2000	
20			NO COLOR				500	

RESISTOR COLOR CODES

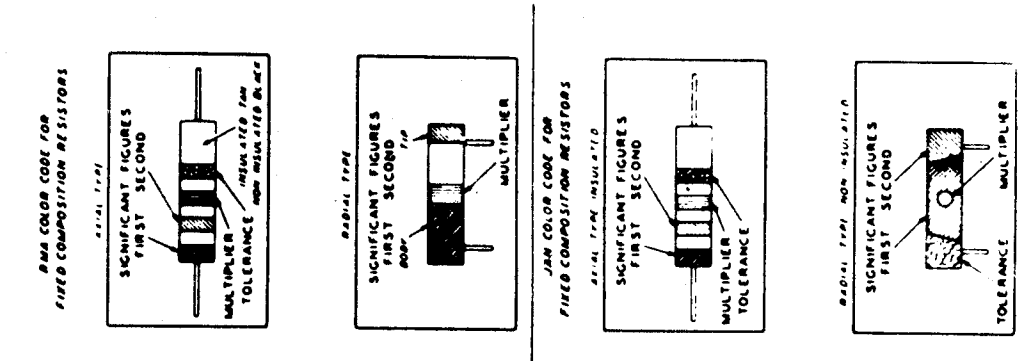

CAPACITOR COLOR CODES

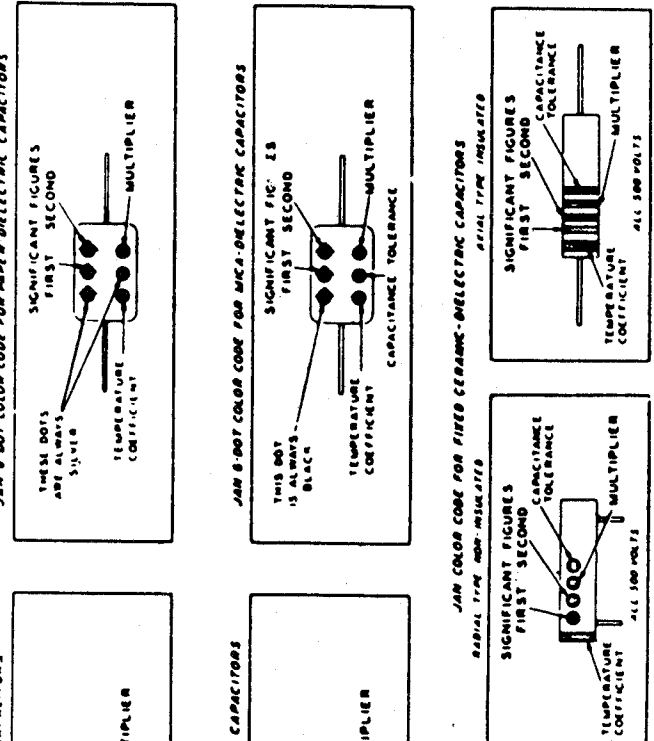

RMA RADIO MANUFACTURERS ASSOCIATION
JAN JOINT ARMY-NAVY



INDEX

SUBJECT	FIGURE OR TABLE	PARAGRAPH	PAGE
A			
Adjusting Output Voltage		4-6	4-2
Antenna Simulator, Use of	4-4, 6-23	4-11	4-5
Applicable Color Codes and Miscellaneous Data	7-6		7-29
Attenuators, Fixed	6-22, 6-24	4-13, 4-14	4-6
Attenuator, Step			
Calibration		6-19	6-8
Removal of		6-13	6-3
Top and Bottom Views	6-20		6-23
Attenuator, Variable RF		4-12	4-6
Audio and Metering Unit			
Interior View	6-17		6-22
Rear View	6-16		6-22
Audio Compartment Assembly		6-12	6-3
Audio Output		4-7b	4-2
Audio Response Test		4-16b(4)	4-10
Audio Voltage		2-2d	2-3
B			
Beat Amplifier		2-5c	2-7
Buffer Amplifier			
Rear View	6-6		6-5
Bottom View	6-7		6-6
Side View	6-5		6-5
Buffer Stage	2-3	2-2c	2-2
C			
Calibrating the Step Attenuator	(See Attenuator, Step)		
Calibrating the Voltmeter	(See Voltmeter)		
Carrier Oscillator	2-2	2-2b	2-2
Carrier Oscillator Bracket	6-8		6-7
Cathode Follower		2-5d	2-7
Cathode Follower Stage	2-6	2-3c	2-4
Charts			
General Test Procedure for Localizing Trouble	6-3		6-13
Percentage Modulation	6-14		6-20
Routine maintenance check	5-1	5-1	5-0
Suggested tests for locating trouble	6-4		6-14
Trouble Shooting	6-2		6-12
Voltage and Resistance	6-15		6-21
Circuits, General Description of		2-1	2-1
Combined Parts and Spare Parts List	7-4		7-3
Coupling to the Receiver Under Test		4-10	4-5
Cross Reference Between Symbol Number and Figure			
Location	6-8		6-35
Crystal Calibration		2-5a	2-6
Crystal Calibrator			
Analysis of	2-9	2-5b	2-6
Limitations of		6-16b	6-4
Operation of		4-5	4-1
Crystal Calibrator Bracket Assembly	6-9	6-11	6-3

CHANGE 3

SUBJECT	FIGURE OR TABLE	PARAGRAPH	PAGE
D			
Data			
Frequency Calibration	6-1	6-11
Reference	1-5	1-5
Shipping	1-2	1-3
Description, detailed		1-2	1-1
Diagrams			
AC Power Source	2-14	2-11
Antenna Simulator SM-35/URM-25 with Input Impedance Frequency Curve	4-8	4-5
Attenuator, Fixed	2-10	2-10
Attenuator, Step	2-8	2-8
Buffer Stage	2-3	2-3
Crystal Calibrator	2-9	2-9
Modulation Cathode Follower and Crystal Rectifier	2-6	2-6
Modulation Oscillator	2-5	2-5
Output Amplifier Stage	2-4	2-3
Power Supply	2-12	2-11
RF Oscillator	2-2	2-2
RF Signal Generator	2-1	2-1
Vacuum Tube Voltmeter	2-7	2-7
Vernier Reading of Frequency Scale	4-2	4-2
Voltage Regulator	2-13	2-11
E			
Electron Tube Complement	1-4	1-5
Equipment Similarities	1-3	1-4
Equipment supplied	1-1	1-3
Equivalent Circuits			
With Impedance Adapter added	4-5	4-3
With Series Matching Resistor added	4-6	4-3
With Shunt Resistor added	4-7	4-4
Exterior Views	(See Views of Units)		
External Modulation			
Analysis of		2-4	2-5
Operation		4-8	4-2
F			
Failure Report	6-1	6-0
Fixed Attenuators	(See Attenuator, Fixed)		
Frequency Calibration			
Chart	6-1	6-17b	6-6
Procedure	6-12	6-17	6-5
Readjustment of	6-12	6-16	6-4
Frequency Calibration Data	(See Data, Frequency Calibration)		
Frequency Interpolation	4-2	4-5c	4-1
Frequency Calibration		6-16b	6-4
Fuse Locations	5-3	5-1
Fuse Failure	5-2	5-2	5-0
G			
General Chart of Test Procedure	6-3	6-13
General Instructions for Use	(See Instructions)		

SUBJECT	FIGURE OR TABLE	PARAGRAPH	PAGE
I			
Impedance Adapter	4-3, 6-25		4-3
Installation		3-2	3-1
Instructions, General, for use		4-16	4-7
Interior Views	(See Views of Units)		
Internal Modulation			
Analysis of		2-3 ^a	2-4
Operation		4-7 ^a	4-2
L			
List of Effective Pages			A
List of Illustrations			i
List of Manufacturers	(See Manufacturers)		
List of Major Units	(See Major Units)		
List of Parts	7-4		7-3
List of Tables			iii
Localization, Theory of		6-1	6-1
Lubrication		5-3	5-0
M			
Manufacturers, List of	7-5		7-28
Major Units, List of	7-2	1-1 ^d	1-1
Measuring Receiver Gain per Stage		4-16 ^b (5)	4-10
Method for Calibrating the RF Signal Generator Set AN/URM-25D of Frequencies Below 100 Kilo- cycles	6-12	6-17 ^a (4)	6-6
Methods for Correctly Terminating the Signal Generator at J102	4-1, 4-2	4-9	4-2
Modulated Operation		4-16 ^c	4-10
Modulation			
External		2-4, 4-8	4-2
Internal		2-3, 4-7	4-2
Modulation Metering	2-6	2-3 ^d	2-5
O			
Operation, Principles of		1-1	1-1
Operation, Summary of		4-15	4-7
Operational Summary of Front Panel Controls	4-3		4-9
Oscillator Bracket Assembly		6-10	6-3
Oscillator Compartment			
Rear View	6-10		6-10
Output Amplifier			
Analysis of	2-4	2-2 ^d	2-3
P			
Parts List	7-4		7-3
Parts, Removal and Replacement of		6-9	6-3
Percentage Modulation Calibration		6-18 ^d	6-8
Power Circuit Operation		4-2	4-1
Power Supply PP-977/URM-25D			
Analysis of		2-10	2-10
Description		1-2 ^r	1-3

CHANGE 3

SUBJECT	FIGURE OR TABLE	PARAGRAPH	PAGE
Power Supply PP-977/URM-25D - (Continued)			
Outside Cabinet	6-4	6-4
Rear Bottom	6-3	6-2
Top and Bottom Views	6-2	6-2
View for Removal	6-3	6-2
Principle Circuits	2-1c	2-1
R			
Rated Tube Characteristics	6-6	6-29
Readjustment of Frequency Calibration	6-12	6-16	6-4
Receiver Alignment	4-16b(6)	4-10
Receiver Alignment above 50 Megacycles	4-16b(7)	4-10
Receiver Output	4-16d	4-10
Receiver Overall Sensitivity	4-16e	4-10
Receiver Tests	4-16b	4-7
Reference Data	(See Data, Reference)	
References for Correctly Terminating the Generator at J102	4-1	4-4
Removal and Replacement of Parts	6-9	6-3
Removal of Audio Compartment Assembly	(See Audio Compartment Assembly)	
Removal of Oscillator Bracket Assembly	(See Oscillator Bracket Assembly)	
Removal of Step Attenuator	(See Attenuator, Step)	
Removing the Signal Generator and Power Supply from the Cabinet	6-8	6-1
Replacing Buffer and Amplifier Circuit Components	6-15	6-4
Replacing RF Oscillator Circuit Components	6-14	6-3
RF Attenuator controls	1-2k	1-2
RF Connectors and Cable Assemblies	6-26	6-27
RF Output Voltage Calibration	6-18c	6-8
RF Signal Generator Set AN/URM-25D		
Complete Equipment	1-1	1-0
Functional Block Diagram	(See Diagram)	
Outline Dimension Drawing	3-2	3-0
Unpacking Procedure	3-1	3-0
Simplified Procedure for Operating	4-15	4-7
RF Signal Generator SG-85/URM-25D		
Outside Cabinet	6-4	6-4
Bottom View	6-13	6-11
Front View	6-2	6-2
Top View	6-18	6-22
Routine Maintenance Check Chart	(See Chart, Check)	
S			
Selectivity Test	4-16b(3)	4-8
Sensitivity Test	4-16b(2)	4-8
Setting Carrier Frequency	4-4	4-1
Setting the Meter Zero	4-3	4-1
Shipping Data	(See Data, Shipping)	
Shipping Weights and Dimensions of Spare Parts Boxes	7-2	7-1
Signal Channel	2-2a	2-2
Signal Generator SG-85/URM-25D		
Front View for Removal	6-2	6-2
Rear View	6-3	6-2
Signal Output Circuit	2-4, 2-8	2-2f	2-4
Spare Parts	(See Parts List)	

SUBJECT	FIGURE OR TABLE	PARAGRAPH	PAGE
Standard Antenna Electrical Constants	4-16f	4-11
Standard Levels	4-16g	4-11
Step Attenuator	(See Attenuator, Step)		
Summary of Operation	4-15	4-7
Switching	2-4b	2-5
System Trouble Shooting	6-3	6-1
T			
Terminating the Signal Generator			
Analysis of	2-7	2-9
Operation	4-9	4-2
Test Equipment	6-2	6-1
Test Lead	2-9	2-10
Tests, Receiver	4-16b	4-7
Theory of Localization	6-1	6-1
Tube Operating Voltages and Currents	6-5	6-4	6-1
Tube Socket Electrical Measurements	6-5	6-1
Turret Selector Switch	6-11	6-10
U			
Unpacking	3-1	3-0
V			
Vacuum Tube Voltmeter	2-7	2-2e	2-4
Variable RF Attenuator			
Analysis of	2-8	2-6	2-7
Use of	4-12	4-6
Views of Units	6-7	6-1
Voltmeter			
As Output Meter	4-16b	4-11
Calibration of	6-18	6-6
Zero Adjustment	6-18b	6-6
W			
Weights and Dimensions of Spare Parts Boxes	7-1	7-1
Winding Data	6-7	6-6	6-1





