

WAR DEPARTMENT
TECHNICAL MANUAL

TM 11-873

RADIO SET
SCR-614-A

RADIO RECEIVER BC-969-A

POWER SUPPLY UNIT RA-61-A

RESTRICTED

Dissemination of restricted matter.—The information contained in restricted documents and the essential characteristics of restricted materiel may be given to any person known to be in the service of the United States and to persons of undoubted loyalty and discretion who are cooperating in Government work, but will not be communicated to the public or to the press except by authorized military public relations agencies. (See also par. 18b. AR 380-5, 28 Sep 1942.)

WAR DEPARTMENT TECHNICAL MANUAL
TM 11-873 RESTRICTED

RADIO SET SCR-614-A
RADIO RECEIVER BC-969-A
POWER SUPPLY UNIT RA-61-A

This document contains information affecting the national defense of the United States within the meaning of the Espionage Act, 50 U.S.C., 31 and 32, as amended. Its transmission or the revelation of its contents in any manner to an unauthorized person is prohibited by law.

Dissemination of restricted matter.--The information contained in restricted documents and the essential characteristics of restricted materiel may be given to any person known to be in the service of the United States and to persons of undoubted loyalty and discretion who are cooperating in Government work, but will not be communicated to the public or to the press except by authorized military public relations agencies. (See also par. 18*b*. AR 380-5, 28 Sep 1942.)

WAR DEPARTMENT

12 NOVEMBER 1943

WAR DEPARTMENT
WASHINGTON 25, D. C., 12 November 1943.

TM 11-873, Radio Set SCR-614-A, is published for the information
and guidance of all concerned.

[A. G. 062.11 (5-11-43).]

By order of the Secretary of War:

G. C. MARSHALL,
Chief of Staff.

Official:

J. A. ULIO,
Major General,
The Adjutant General.

Distribution: X

(For explanation of symbols see FM 21-6.)

TABLE OF CONTENTS

U113

.2

T M 11: 873

1943

SECTION I. DESCRIPTION

Paragraph

Page

1. General.....	1
2. Main components, weights, and dimensions. .	1
3. Radio Receiver BC-969-A.....	2
4. Case CS-109-A.....	6
5. Mounting FT-411-A.....	6
6. Power Supply Unit RA-61-A.....	6

II. INSTALLATION AND OPERATION

7. Unpacking.....	10
8. Installation in vehicles.....	10
9. Installation in fixed locations.....	11
10. Installation in Radio Direction Finder Central TC-8 and Radio Intercept Central TC-9..	11
11. Preparation of Radio Set SCR-614-A for operation.....	11
12. Operation.....	14

III. FUNCTIONING OF PARTS

13. General circuit.....	17
14. Antenna circuit.....	17
15. Radio frequency amplifier.....	18
16. High frequency oscillator.....	19
17. Converter.....	20
18. First i-f Stage.....	21
19. Second i-f Stage.....	22
20. Audio detector.....	22
21. Noise limiter.....	23
22. Audio frequency amplifier.....	23

III

M574749

TABLE OF CONTENTS (Continued)

<i>Paragraph</i>	<i>Page</i>
23. Automatic volume control	24
24. Beat oscillator	25
25. Auxiliary diode circuit	25
26. Tuning indicator	26
27. Voltage regulator	26
28. Voltage supply	26
29. Power Supply Unit RA-61-A	26
IV. MAINTENANCE	
30. Operational check in field	28
31. Field upkeep	29
32. Trouble location and remedy chart	34
33. Alignment procedure	36
34. Disassembly and reassembly of front panel dial assembly	40
35. Replacement of crystal filter, switch and socket	42
36. Replacement of fixed capacitors	43
37. Replacement of band switch and limiter switch	43
38. Replacement of transformers	45
39. Replacement of the gang capacitor	46
40. Replacement of tube sockets	47
41. Servicing Power Supply Unit RA-61-A	47
42. Performance characteristics	50
43. Moisture proofing	51
V. SUPPLEMENTARY DATA	
44. Tabular list of replaceable parts	54
45. Index of manufacturers	94

LIST OF ILLUSTRATIONS

<i>Fig. No.</i>	<i>Title</i>	<i>Page</i>
1.	Radio Set SCR-614-A	VIII
2.	Radio Receiver BC-969-A, back view	3
3.	Radio Receiver BC-969-A in Case CS-109-A on Mounting FT-411-A, front view	5
4.	Power Supply Unit RA-61-A on Mounting FT-414, diagonal view	7
5.	Power Supply Unit RA-61-A on Mounting FT-414, back view	9
6.	Power Supply Unit RA-61-A, schematic circuit diagram . . .	27
7.	Radio Receiver BC-969-A, tube sockets and transformers resistance diagram, bottom view of chassis	32
8.	Radio Receiver BC-969-A, tube socket voltage diagram, bottom view of chassis	33
9.	Radio Receiver BC-969-A, top view	37
10.	Power Supply Unit RA-61-A, interior view	48
11.	Power Supply Unit, RA-61-A, practical wiring diagram . . .	49
12.	Radio Receiver BC-969-A, schematic circuit diagram	97
13.	Radio Receiver BC-969-A, simplified schematic circuit diagram	99
	Auxiliary diode circuit	
	Automatic volume control circuit	
14.	Radio Receiver BC-969-A, bottom plate removed, bottom view	101
15.	Radio Receiver BC-969-A, practical wiring diagram	103

DESTRUCTION NOTICE

WHY— To prevent the enemy from using or salvaging this equipment for his benefit.

WHEN—When ordered by your commander, or when you are in immediate danger of capture.

HOW— 1. Remove chassis from case by loosening the eight knurled screws around the front edges and then:

2. Smash—Use sledges, axes, hand-axes, pick-axes, hammers, crowbars, heavy tools, etc.

3. Cut—Use axes, hand-axes, machete, etc.

4. Burn—Use gasoline, kerosene, oil, flame-throwers, incendiary grenades, etc.

5. Explosives—Use firearms, grenades, TNT, etc.

6. Disposal—Bury in slit trenches, fox-holes, other holes. Throw in streams. Scatter.

7. USE ANYTHING AVAILABLE FOR DESTRUCTION OF THIS EQUIPMENT.

WHAT—1. Smash—Transformers, oscillator coils, tubes, capacitors, potentiometers, chokes. (If there is time, first remove the shield cans from these units by removing the two top nuts—then directly smash the components and cut the wires.)

2. Cut—If there is time, remove the bottom plate from chassis by removing the ten screws around the bottom edges and cut wiring and rip out resistors, capacitors and potentiometers.

3. Burn—This technical manual.

4. Bury or scatter—Any or all of the above pieces after breaking.

DESTROY EVERYTHING

SAFETY NOTICE

THE HIGH VOLTAGE OUTPUT OF POWER SUPPLY UNIT RA-61-A IS 250 VOLTS, APPEARING ACROSS TERMINALS 8A AND 8F. THIS 250 VOLTS IS APPLIED TO THE TUBE PLATES AND OTHER POINTS ON RADIO RECEIVER BC-969-A THROUGH THE POWER SWITCH, 76, ACROSS TERMINALS F AND A. THE VOLTAGE ACROSS TERMINALS C AND D ALSO IS DANGEROUSLY HIGH. DON'T TOUCH THESE HIGH VOLTAGES! THE SHOCK MIGHT KILL YOU.

CORD CD-873

CORD CD-872

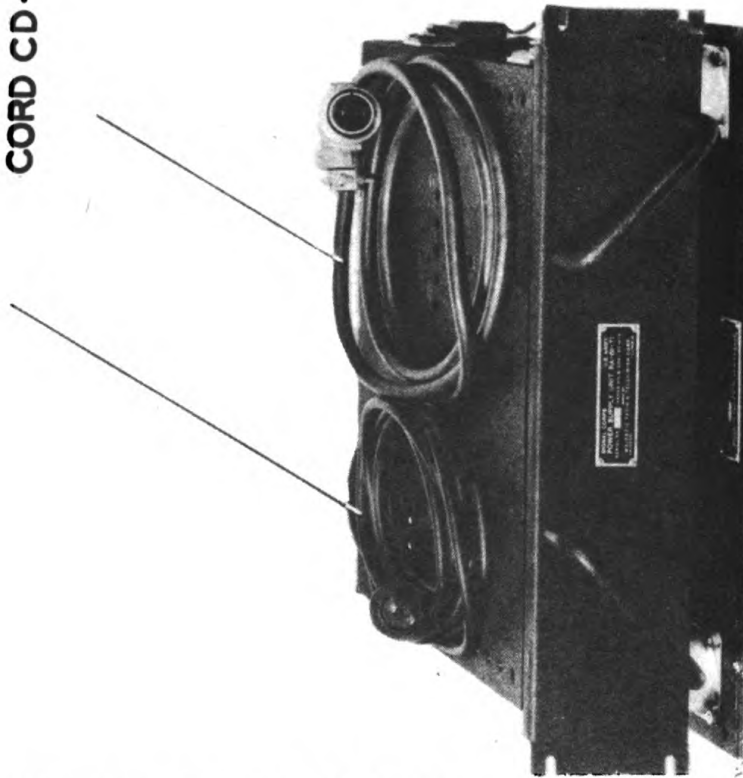

Power Supply Unit RA-61-A



Radio Receiver BC-969-A

Figure 1. Radio Set SCR-614-A, front view.

RESTRICTED

This manual supersedes TM11-873, dated 31 August 1943 and 28 October 1943.

SECTION I DESCRIPTION

	Paragraph
General	1
Main components, weights, and dimensions	2
Radio Receiver BC-969-A	3
Case CS-109-A	4
Mounting FT-411-A	5
Power Supply Unit RA-61-A	6

1. General.—Radio Set SCR-614-A is a low frequency communication set used for intercept purposes. It covers the frequency range of 15-150 kilocycles and receives c-w and amplitude modulated tone and voice signals. It has a power output of two watts. Radio Set SCR-614-A consists mainly of Radio Receiver BC-969-A in Case CS-109-A installed on Mounting FT-411-A (figure 1). Neither the case nor mounting is used when the receiver is placed in a rack; the case may be used without the mounting when the receiver is set on a table; the mounting must be used in vehicles. Power is furnished by Power Supply Unit RA-61-A on mounting FT-414 (figure 1) installed near the receiver. The mounting need not be used when the power supply unit is mounted on a rack or placed on a table. The overall size of the receiver in the case and on the mounting is 21¹/₄ inches long, 12¹/₄ inches high, and 17¹⁵/₁₆ inches deep; the weight is 78.1 pounds. The overall size of the power unit on the mounting is 19 inches long, 5⁵/₈ inches high, and 14 inches deep; the weight (including Cords CD-872 and CD-873) is 63.7 pounds.

2. MAIN COMPONENTS, WEIGHTS, AND DIMENSIONS.

Article	Dimensions (in inches)			Weight (pounds)	Sig. C Stock Number
	width	height	depth		
Radio Receiver BC-969-A	19	x 10 ¹ / ₂	x 15 ⁷ / ₈	49.3	
Case CS-109-A	20 ¹ / ₈	x 10 ¹ / ₂	x 13 ¹ / ₂	18.5	
Mounting FT-411-A	21 ¹ / ₄	x 3 ¹ / ₂	x 13 ¹ / ₂	10.2	
Power Supply Unit RA-61-A	19	x 4	x 13 ⁷ / ₈	52.1	
Mounting FT-414	18 ¹ / ₄	x 3 ¹ / ₂	x 11 ³ / ₄	9.5	
Cord CD-872	length	7 feet		1.5	
Cord CD-873	length	10 feet		0.6	

3. RADIO RECEIVER BC-969-A.—Radio Receiver BC-969-A is a 12-tube, superheterodyne receiver covering the frequency ranges of 15-30 kilocycles in band 1, 30-67.5 kilocycles in band 2, and 67.5-150 kilocycles in band 3. The receiver has automatic volume control, a noise limiter, a crystal filter, a beat oscillator, and an electron ray tuning indicator. It has an illuminated dial calibrated in kilocycles with a mask controlled by the **FREQ. BAND** switch, showing only the range in use. The receiver filaments operate on 12.6 volts, 1.95 amperes, alternating or direct current, and the plate supply is 250 volts, 120 milliamperes direct current. Power is usually supplied by Power Supply Unit RA-61-A, but may be supplied by Power Supply Unit PE-223 or by batteries.

a. Input connections.—All input connections to the receiver are at the back of the chassis. They are:

(1) **ANTENNA 100 ohm.**—This connection is marked 100 ohm under **ANTENNA** (figure 2). Plug PL-284 is connected to Socket SO-264, through Adapter PL-293. This connection is normally for a balanced transmission line but you can, if necessary, use it with either side of the input grounded to the chassis. The antenna should be as long as possible in order to balance the line for the best results. The proper antenna would be 9300 feet long, or nearly two miles, but the receiver will operate with a much shorter antenna; in fact, good reception is possible with less than 100 feet of antenna even on the 100 ohm input.

(2) **ANTENNA WHIP.**—This connection is for a 30-foot whip antenna. Plug PL-259 is connected to Socket SO-239, through Adapter M-359. The sensitivity of the receiver is lower using this connection, so use it when only a short antenna is available.

(3) **Power input receptacle.**—This is the large unmarked socket with 6 pins. The plug on Cord CD-872 from the power supply unit connects to this receptacle. There are terminal pins for all the required filament and plate supply connections.

b. Output connections.—There is only one output connection on the front panel; the rest are at the back of the chassis.

(1) **Headset jack.**—This jack marked **OUTPUT** on the front panel is for a headset having 250 ohms impedance, such as Headset HS-30.

(2) **AUXILIARY DIODE.**—There are three screw terminals on the panel marked **AUXILIARY DIODE**. The center terminal is marked **GROUND** (grounded to chassis), the others are marked **-(negative)** and **+(positive)**. These terminals are used to connect an external d-c meter, or an oscilloscope for alignment purposes or for observation of the modulation envelope.

(3) **OUTPUT terminal panel.**—This panel has five screw type terminals having the following output impedances as marked:

- (a) 250 OHMS to GROUND
- (b) 250 OHMS balanced to ground
- (c) 4000 OHMS to GROUND

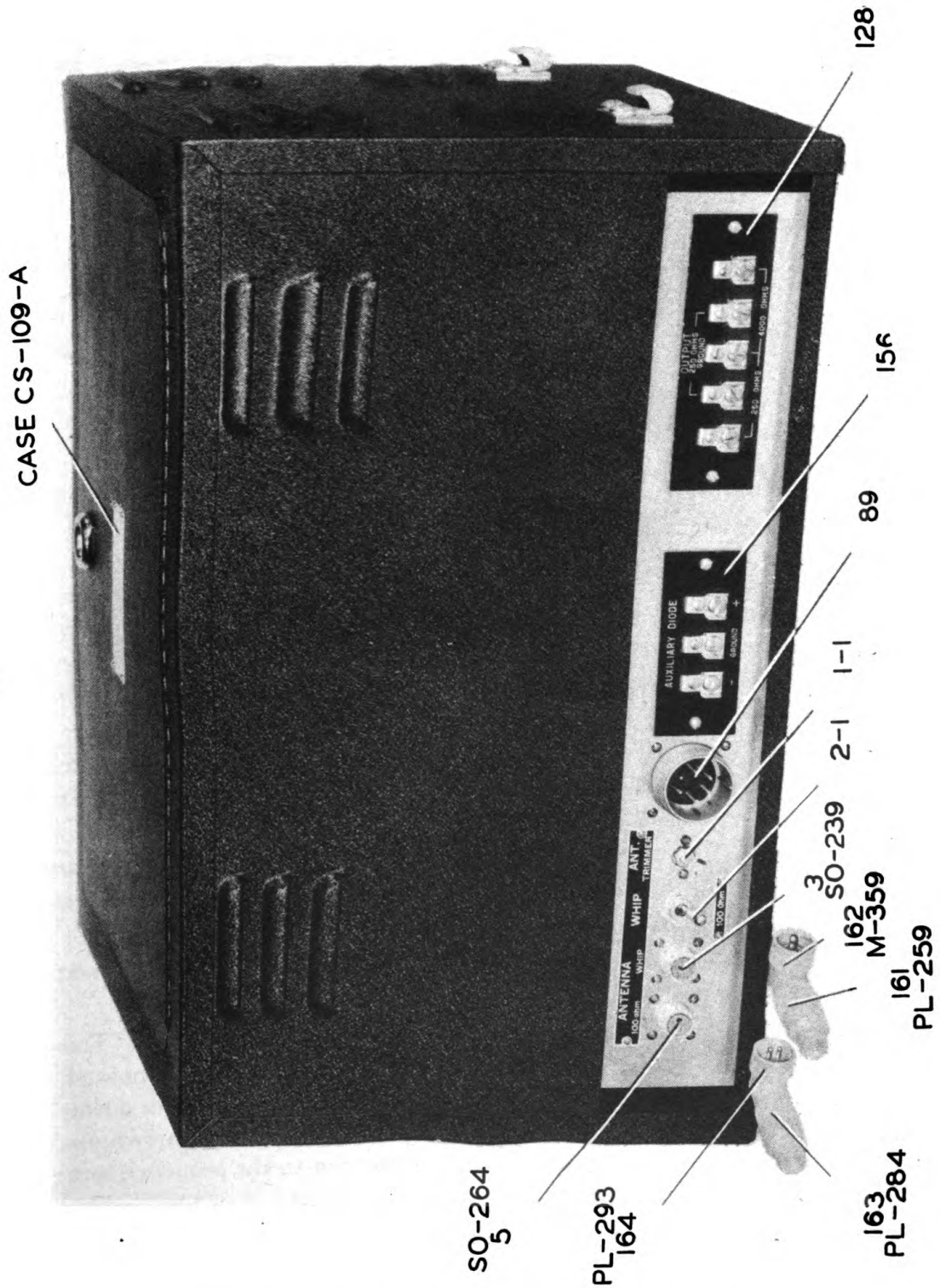

Figure 2. Radio Receiver BC-969-A, back view

These terminals are used to connect a speaker or headset having a similar impedance. The OUTPUT jack on the front panel is connected to the 250 OHMS to GROUND terminals.

c. Operating controls.—The main controls for operating the receiver are on the front panel (figure 3).

(1) TUNING knob.—The TUNING knob has a ratio of 36 to one. It turns 18 times in covering the range of each of the three frequency bands.

(2) FREQ. BAND knob.—This control selects the desired frequency band.

(3) LIMITER knob.—This knob controls the noise limiter circuit. At OFF the limiter is not working. Positions 1, 2, and 3 give increasingly more limiting of noise.

(4) AUDIO GAIN control.—This knob controls the volume of the receiver.

(5) AUDIO TONE control.—As this knob is turned to the right (clockwise), the higher audio frequencies are cut off. It is also used to decrease the effect of certain types of interference.

(6) CRYSTAL SELECTIVITY control.—This knob controls a switch having three positions. When the pointer is at OUT, the crystal filter isn't working. Positions 1 and 2 give two degrees of crystal selectivity. The crystal filter is used to filter out channels close to the one being received; hence, it is especially useful in receiving CW.

(7) BEAT OSC. PITCH knob.—This control adjusts the pitch of the beat oscillator over a range of 5000 cycles either side of the center position.

(8) POWER ON-OFF switch.—This switch controls the a-c input to the power supply unit through Cord CD-872; it turns the power to the receiver on and off.

(9) BEAT OSC. ON-OFF switch.—This switch turns the beat oscillator on and off.

(10) WHIP-100 Ohm antenna switch.—(See Figure 2.) This switch (on back of chassis) changes the antenna connections as marked, depending on the type of antenna you are using. When thrown downward toward 100 Ohm the whip antenna is grounded. When thrown upward toward WHIP, the whip antenna is connected to the proper circuit.

(11) ANT. TRIMMER.—This trimmer couples the whip antenna and is seldom adjusted. It is adjusted and locked in position as the receiver is issued and must not be changed except in special cases*.

(12) HI-LOW output power control.—This switch is on top of the chassis (figure 9). You can reach it by lifting the lid of the receiver

*Antennas having a capacitance greater than 200 micromicrofarads require slight readjustment to improve the antenna circuit tuning. However, this detunes the 100 ohm input circuit so is seldom desirable.

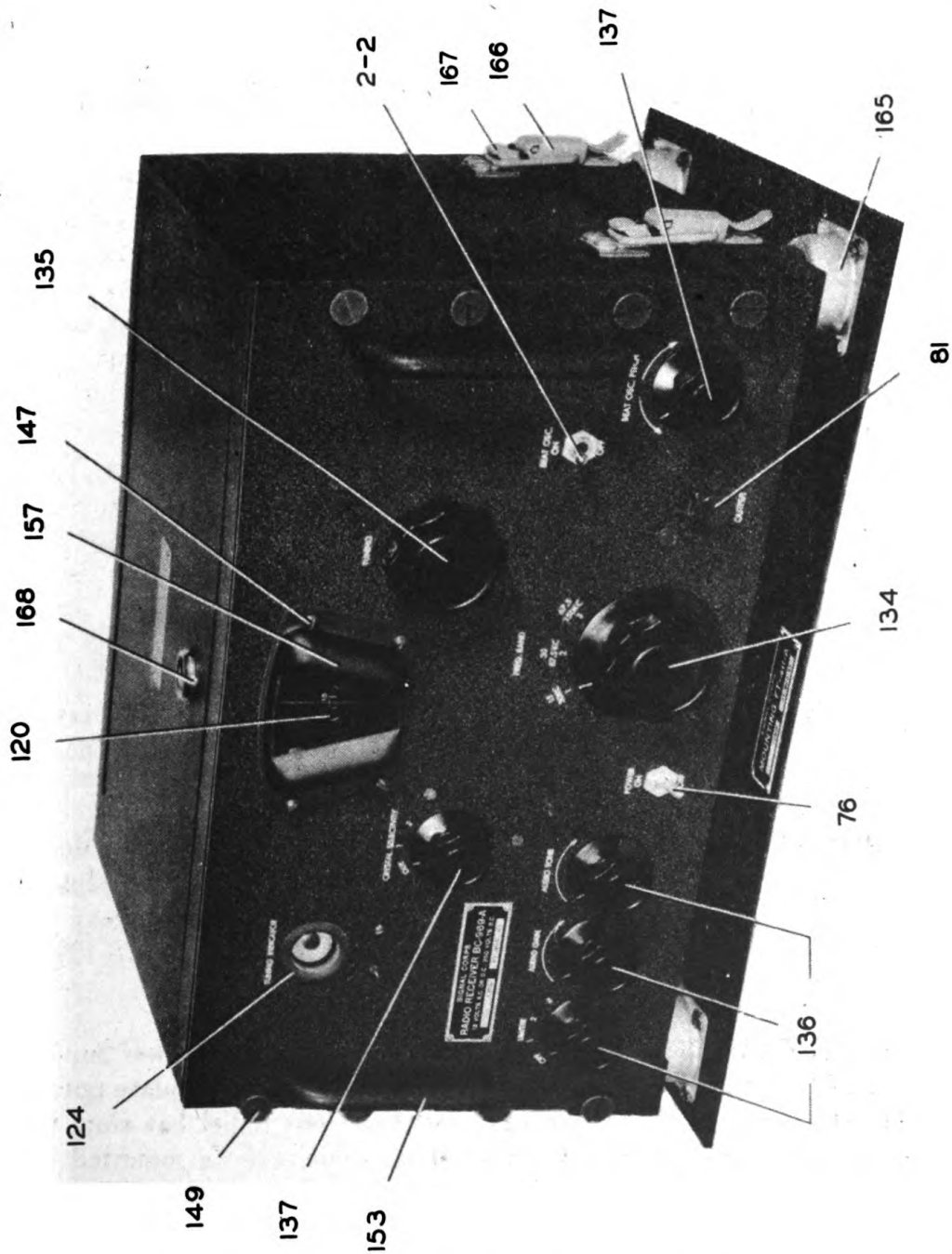

Figure 3. Radio Receiver BC-969-A in Case CS-109-A on Mounting FT-411-A, front view

case. The switch is kept on HI except when a telephone line is connected to the receiver; then the LOW position is used so that the line cannot be overloaded if the AUDIO GAIN control is turned up too far.

d. Vacuum tubes.—Radio Receiver BC-969-A uses twelve tubes which are shipped installed in their sockets except for the tuning indicator tube. Also, there is a kit containing one spare tube for each socket. The tubes used are:

	Commercial Number	Sig. C. Number
(V ₁) R-F amplifier	12SK7	VT-131
(V ₂) Converter	12SA7	VT-161
(V ₃) H-F oscillator	12J5GT	VT-135
(V ₄) First i-f	12SK7	VT-131
(V ₅) Second i-f	12SK7	VT-131
(V ₆) Detector & noise limiter	12H6	VT-214
(V ₇) Auxiliary diode	12H6	VT-214
(V ₈) A-F amplifier	12SQ7	VT-104
(V ₉) Output	12A6	VT-134
(V ₁₀) Beat oscillator	12J5GT	VT-135
(V ₁₁) Tuning indicator	1629	VT-138
(V ₁₂) Voltage regulator	VR 150-30	VT-139

4. CASE CS-109-A.—Case CS-109-A houses Radio Receiver BC-969-A. It is made of steel and has ventilating slits and four hooks used to attach it to the Mounting FT-411-A (figure 3).

5. MOUNTING FT-411-A.—This is a shock-proofed mounting made especially for installing the receiver in a vehicle. It has a steel bedplate and rubber shock mounts to which are bolted two support angles. On the angles are four catches which clamp on to the hooks on Case CS-109-A and fasten the two together (figure 3).

6. POWER SUPPLY UNIT RA-61-A.—a. General.—Power Supply Unit RA-61-A (figure 4) supplies a-c heater voltage and d-c plate potentials to the receiver. It is in a case and the front panel has slots for mounting in a relay rack. When used in vehicles it is mounted on Mounting FT-414. Cord CD-873 connects it to the line supply and Cord CD-872 connects it to the receiver. The power unit has two 5U4G rectifier tubes, one in use and one spare. These tubes are inside the right hand door (figure 5) with a ring catch at the back. The power unit is turned on and off by the POWER ON-OFF switch on the front panel of the receiver.

b. Power input.—Power Supply Unit RA-61-A will work from either 115 or 230 volts 50 to 60 cycles alternating current. Inside the right hand back door (figure 5) is a line voltage switch which must be thrown

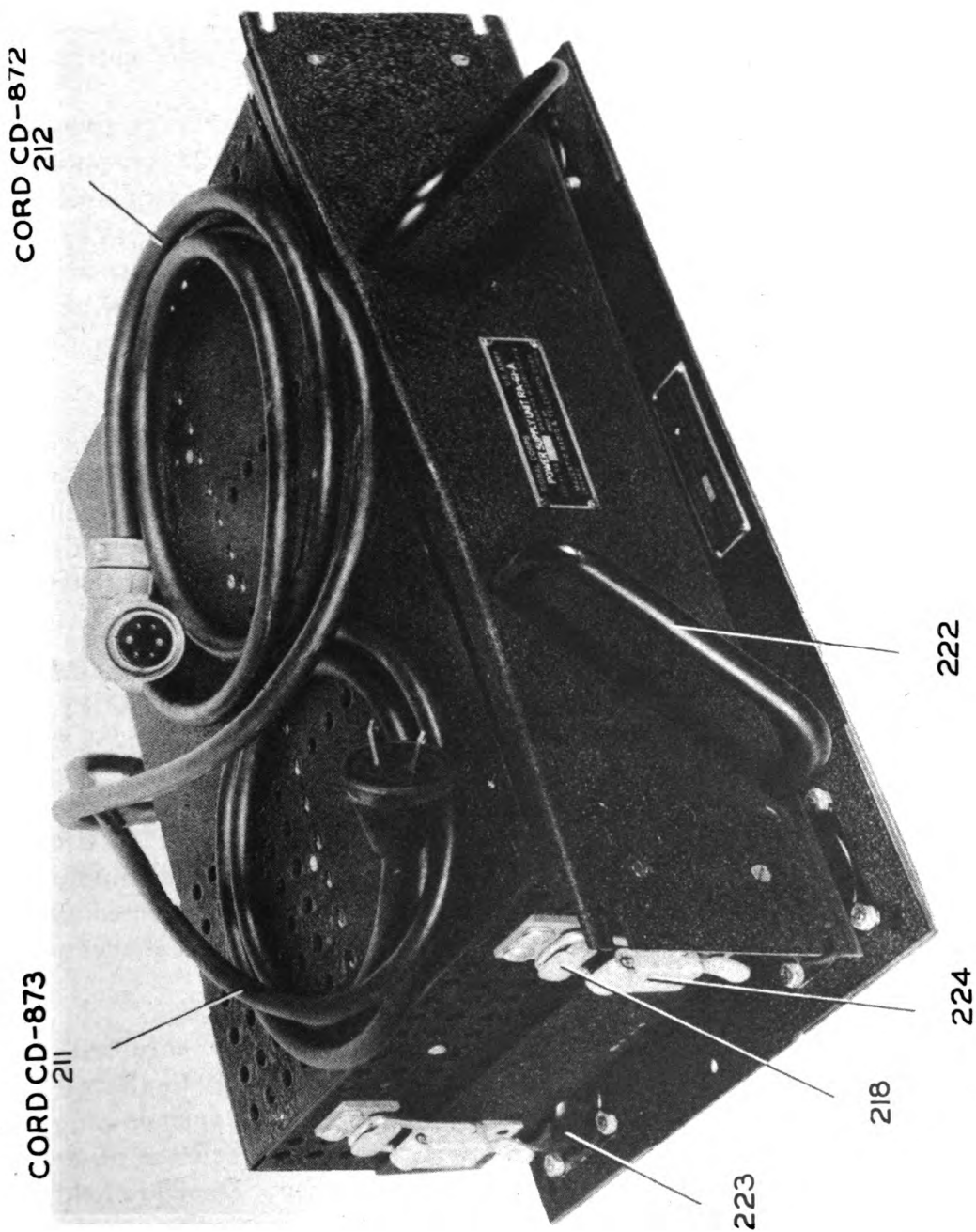

Figure 4. Power Supply Unit RA-61-A on Mounting FT-414, diagonal view

toward the 115 V. or 230 V. position, depending on which line voltage you are using. The switch has a locking device. The black thumbscrew must be loosened before the position of the switch can be changed. While the ordinary voltages are 115 or 230 volts, the power unit will work from 100 to 130 volts in the 115 V. position and 200 to 260 volts in the 230 V. position with corresponding changes in output voltages.

c. Output.—With 115 or 230 volts input, the power unit gives a constant output of 250 volts at 120 milliamperes direct current for plate supply. With other input voltages the output will vary. The filament supply voltage can be set at either 6.3 V. (at 6 amps) or 12.6 V. (at 3 amps) alternating current by the switch in the back of the power unit. This switch also has a slide-locking device held by a thumbscrew. Be sure the switch is kept locked in the 12.6 V. position when using the BC-969-A.

d. Fuses.—Between the two switches mentioned above are two fuses marked $1\frac{1}{2}$ AMP. and 3 AMP. These are on the incoming supply line; the $1\frac{1}{2}$ AMP. for a 230-volt line and the 3 AMP. for a 115-volt line. Be sure the line voltage switch is in the correct position or you will burn out a fuse. There are three spare fuses of each size inside the left hand door (figure 5).

CAUTION: ALWAYS DISCONNECT THE POWER UNIT FROM THE LINE BEFORE OPENING EITHER OF THE BACK DOORS. THERE ARE HIGH VOLTAGES ON THE REAR PANEL.

e. Cord CD-872.—This is a seven-foot shielded cord covered with a weatherproof jacket. It contains six conductors; two for the POWER ON-OFF switch, two for the plate supply, and two for the heater supply voltage. It is part of Power Supply Unit RA-61-A and is connected to screw terminals on the rear panel. The plug on the other end connects to the power receptacle on the receiver.

f. Cord CD-873.—This is a ten-foot, two-conductor cord with overall weatherproof covering. It connects the power unit to the a-c power line and is furnished connected to the power unit. A male plug at one end connects to the socket on the a-c power line and the other end connects to the power unit by means of solder lugs. These are held under screw type terminals on the rear panel of the power unit near the line voltage switch.

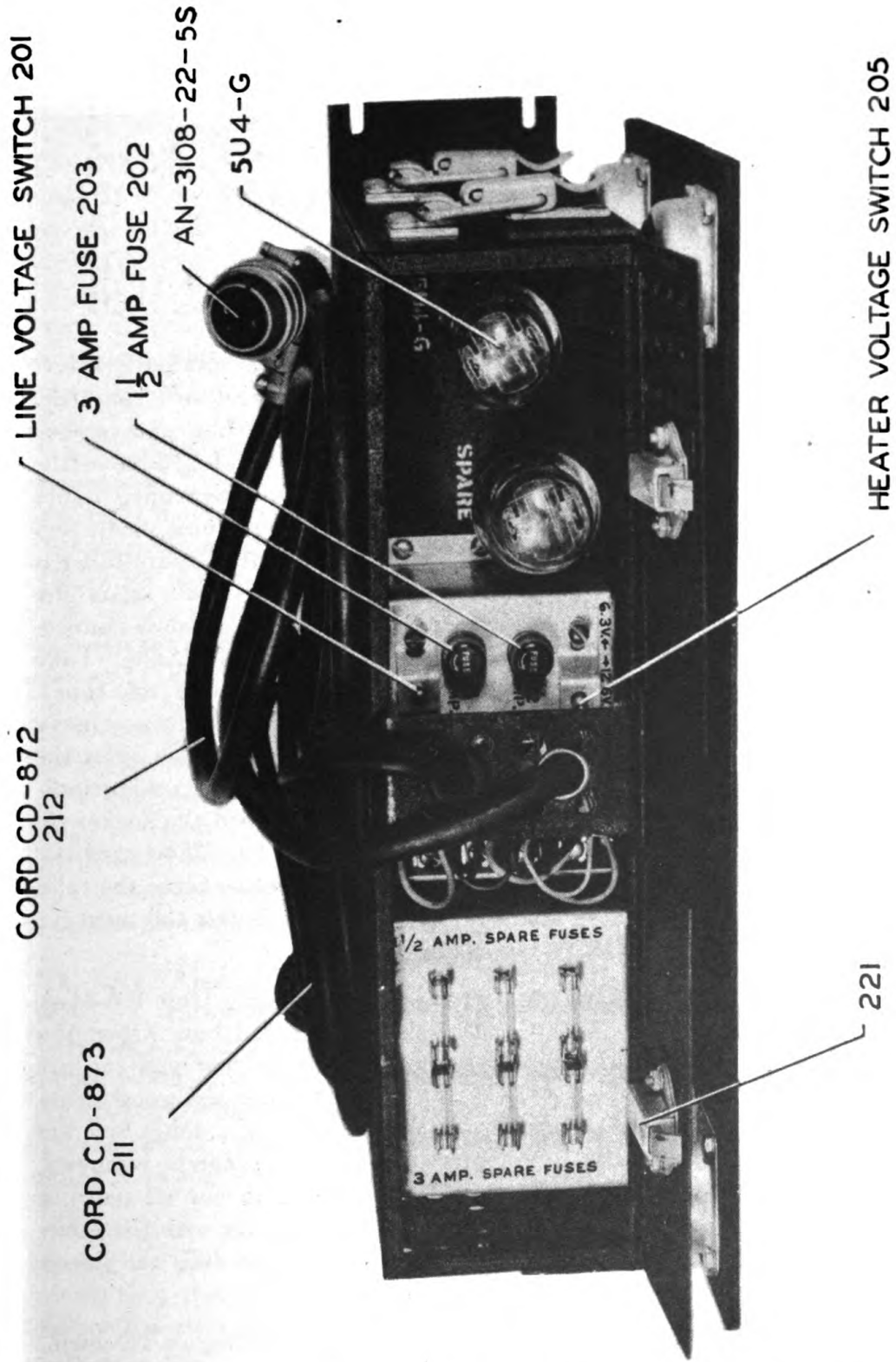

Figure 5. Power Supply Unit RA-61-A, on Mounting FT-414, back view

SECTION II INSTALLATION AND OPERATION

	Paragraph
Unpacking.....	7
Installation in vehicles.....	8
Installation in fixed locations.....	9
Installation in Radio Direction Finder Central TC-8 and Radio Intercept Central TC-9.....	10
Preparation of Radio Set SCR-614-A for operation.....	11
Operation.....	12

7. UNPACKING.—a. Radio Receiver BC-969-A.—Radio Receiver BC-969-A is packed installed in Case CS-109-A and on Mounting FT-411-A in a corrugated box. Open the top of the box and remove side packing materials so that you can lift the set out. Remove the wood cleats from the bottom of the mounting. Unlatch the trunk catches and take the case off of the mounting so that the remaining cleats can be removed. Lift the lid of the receiver case. The kit of spare tubes is on top at the left as you face the receiver. Just below this kit is one containing the tuning indicator tube and cable, and the antenna connectors M-359 fastened to PL-259 and PL-293 fastened to PL-284. Take these kits out. Remove all packing material from around the tubes. Loosen the thumbscrews of the shields on the two 12J5GT tubes, remove the shields and take out the packing material around the tubes. Put the shields and thumbscrews back as they were. Unpack the tuning indicator tube and antenna connectors. Plug the cable into the socket on the chassis marked TUNING INDICATOR (figure 9). Then take the clamp from the mounting bracket and put it on the tube, place the tube in the bracket and tighten the wing screw. Now fasten the antenna connectors to Sockets SO-239 and SO-264.

b. Power Supply Unit RA-61-A.—Power Supply Unit RA-61-A on Mounting FT-414 is packed in another corrugated box. Open the top of the box and remove side packing materials so that you can lift the set out. Unwrap the cords from the unit. Remove the wood cleats from the bottom of the mounting. Unlatch the trunk catches and lift the unit off of the mounting so that the remaining cleats can be removed. Open the two rear doors of the power unit and take out all packing material. Make sure that none of the spare fuses pull out with the packing material. If they do, put them back in the correct clip; the size is engraved on the end of the fuse.

8. INSTALLATION IN VEHICLES.—When installing in a vehicle, the shock Mountings FT-411-A and FT-414 must always be used, fastened to some part of the vehicle. The receiver should be in a position convenient for operation but since there are no operating controls on the power unit, it can be put out of the way provided it is within cable reach of the receiver.

9. INSTALLATION IN FIXED LOCATIONS.—The same general instructions follow for non-vehicular installations as for TC-8 and TC-9 given in Paragraph 10a & b except that the shock-proof mountings don't have to be used.

10. INSTALLATION IN RADIO DIRECTION FINDING CENTRAL TC-8 AND RADIO INTERCEPT CENTRAL TC-9 (Hereafter these will be referred to as TC-8 and TC-9).—Specific locations for Radio Receiver BC-969-A and Power Supply Unit RA-61-A are provided in TC-8 and TC-9. Detailed instructions for the installation of equipment in such centrals is provided in the preliminary instructions issued for them. If specific instructions for the installation are not available, proceed as follows:

a. Radio Receiver BC-969-A.—There are four radio receiver compartments in TC-8 and TC-9. Install Radio Receiver BC-969-A in the upper right hand compartment. Fasten Mounting FT-411-A to the shelf of the compartment using the bolts and wing nuts provided with TC-8 or TC-9 for that purpose. Put the receiver on the mounting. Slide it on the rails toward the back of the compartment but DON'T fasten the trunk catches until you have carried out all instructions in paragraph 11 as far as 11D(8).

b. Power Supply Unit RA-61-A.—There is space in TC-8 and TC-9 below the operating compartments for four power supply units. Any of the four spaces may be used for the RA-61-A, but it is best to use the one next to the bottom. Fasten Mounting FT-414 in the space provided and slide the power unit in place on the rails of the mounting. Don't fasten the trunk catches until you have carried out all instructions in paragraph 11 as far as 11d(9).

11. PREPARATION OF RADIO SET SCR-614-A FOR OPERATION.—**a.** Lift the lid of the receiver. Make sure that every tube is all the way down in the socket and that the tuning indicator cable is plugged firmly into the socket on the chassis marked TUNING INDICATOR (figure 9). See that the tuning indicator tube 1629 is in contact with the rubber grommet on the front panel and that the thumbscrew holding it to the bracket is tight.

b. Remove the four thumbscrews which hold the escutcheon (157), covering the dial, to the front panel (figure 3). Take off the escutcheon and see that the two pilot lights are properly in place in their sockets. Replace the escutcheon and thumbscrews.

c. Open the two rear doors of the power unit.
 (1) Make sure the 5U4G tube is all the way down in its socket.
 (2) See that the screw terminals of Cords CD-872 and CD-87 are tight. Check the leads to see that the right color is on each terminal

as shown on figure 6; red on terminal A, black on B, yellow on C, green on D, white on E, and blue on F. The terminals for the power line Cord CD-873 are marked G and H.

CAUTION: TIGHTEN THE TERMINALS BEFORE CONNECTING THE POWER SUPPLY UNIT TO THE POWER LINE OR YOU MAY GET A SEVERE SHOCK AND DAMAGE THE POWER UNIT.

(3) See that the proper fuse is in each holder marked FUSE. Twist the cap one-quarter turn as the arrow points until the fuse jumps up. Take the fuse out and examine it. Put it back, put the holder cap on and turn it until the fuse sets down. Now push the cap down and give it a quarter turn in reverse of the arrow until it locks.

(4) Determine the exact voltage of the power source and make sure it is of 50 to 60 cycle frequency. You can get this information from the company supplying the power. If a local power source is used, check on the nameplate on the equipment.

(5) Be sure the line voltage switch is in the proper position, 115 or 230 volts. If you have to change the switch, loosen the thumbscrew and throw the switch, then tighten the thumbscrew again.

(6) See that the filament voltage switch is in the 12.6 V. position.

CAUTION: DON'T FORGET TO TIGHTEN THE LOCKING BRACKET THUMBSCREW AFTER CHANGING EITHER VOLTAGE SWITCH.

d. Radio Set SCR-164-A is now ready for cable connections.

CAUTION: BE SURE THAT THE POWER SWITCH ON THE FRONT PANEL IS OFF.

(1) Connect Cord CD-872 to the six-prong receptacle (figure 2) on the back of the receiver. Push the connector into this receptacle and tighten the knurled locking ring so that the plug is securely seated. The plug can't be put in wrong because of the key and keyway on the receptacle and plug. Normally the right angle portion of the plug is upward; however, it can be put together so that the right angle portion points in any of eight directions. It will work in any of these positions with the receiver in Mounting FT-411-A but a specific position may have to be used for some special installation.

(2) Connect the antenna after deciding which plug to use. If you are using a long antenna (over 50 feet), plug it into the twin conductor PL-284 which connects to the socket marked ANTENNA 100 ohm on the chassis (figure 2). When using the 30-foot whip antenna, or any antenna less than 50 feet long, plug it into the single conductor PL-259 which connects to the socket marked ANTENNA WHIP (figure 2).

After inserting the plug into the antenna receptacle, tighten the knurled ferrule of the plug on the threads of the receptacle. Under ordinary conditions DO NOT connect antennas to both WHIP and 100 ohm as there will be interaction between the antenna connections*.

(3) See that the antenna switch (figure 2) is in the proper position. Throw it to WHIP if you're using a whip antenna or to 100 ohm if you're using a long antenna.

(4) See that the ANT. TRIMMER (figure 2) is properly set. The normal setting is marked by a line on the rear panel; the slot of the trimmer should point to the line and the black half of the trimmer screw should be towards the bottom of the receiver. This trimmer is set and locked in the proper position before the receiver is issued so that best results are obtained with any antenna. However, if you find that the trimmer is set with the slot more than 10 degrees off the line, loosen the hex. locking nut with a wrench or long nose pliers, reset the slot to the line, and tighten the nut. For other than normal setting see paragraph 3c(11).

CAUTION: DO NOT TRY TO MAKE AN OFF-NORMAL SETTING UNLESS YOU ARE THOROUGHLY FAMILIAR WITH THE EQUIPMENT OR ARE AN AUTHORIZED MAINTENANCE MAN.

(5) Determine the type and impedance of the output device to be used. If it's a loudspeaker, connect it to the rear OUTPUT panel at the proper impedance points (see paragraph 3b(3) and figure 2). When Headset HS-30 is used, plug it into the OUTPUT jack on the front panel.

(6) If a telephone line is to be connected to the receiver and is likely to be used without continuous monitoring by the receiver operator, the HI-LOW output switch should be set on LOW. This switch is on top of the chassis (figure 9); you can reach it by lifting the case lid. **Under all other conditions keep this switch on HI.**

(7) Make sure there is a ground connection from the receiver chassis to the frame of the TC-8 or TC-9 or to actual ground. You can make this connection to the center screw terminal of either the AUXILIARY DIODE panel or the OUTPUT panel on the rear of the receiver chassis (figure 2). Both of these are connected to the chassis and are marked GROUND. **DON'T FORGET TO DO THIS OR YOU'LL GET AN ELECTRIC SHOCK IF YOU TOUCH ANY PART OF THE RECEIVER.**

*In some special cases you will need to use both input connections. One case is when extremely weak signals must be picked up and all your antennas are too short. In such a spot, try using both the whip and 100 ohm antenna. Be sure the switch is thrown to WHIP. If you still can't get the signal through, unplug the 100 ohm antenna, turn it half way around and plug it back in. Another case in which both antennas are needed is when using the receiver for direction finding. **BUT, REMEMBER, BOTH OF THESE CASES ARE SPECIAL. DON'T TRY THEM UNLESS YOU ARE THOROUGHLY FAMILIAR WITH THE EQUIPMENT.**

(8) Fasten the trunk catches on Mounting FT-411-A to the receiver.

(9) Fasten the trunk catches on Mounting FT-414 to the power unit.

(10) Now plug Cord CD-873 into the power line and the set is ready for operation.

12. OPERATION.—a. Initial control setting.—(1) Turn the POWER switch to ON and allow one minute for the tubes to warm up. The dial lights should light and after about one minute, the tuning indicator tube should show a greenish glow.

(2) If the dark part of the TUNING INDICATOR (figure 3) is not toward the bottom of the receiver, lift the case lid and turn the base of the tube until the dark section is downward.

(3) Set the LIMITER control to OFF.

(4) Turn the AUDIO GAIN knob about two-thirds of the way to the right.

(5) Turn the AUDIO TONE control all the way to the left.

(6) Set the CRYSTAL SELECTIVITY to OUT.

(7) Set the FREQ. BAND control to the desired range.

b. Tuning in signals.—

(1) Turn the TUNING knob until the dial is turned to approximately the frequency desired, then turn the knob slowly back and forth until you pick up the signal.

(2) When a signal is correctly tuned in, the dark section of the TUNING INDICATOR closes. Turn the TUNING knob until the dark section is as small as possible; the signal then is tuned in correctly.

NOTE. This tube also indicates the approximate signal strength; the greater the signal strength, the more nearly will the indicator close. Fading signals are indicated by a widening of the indicator. A rapid flickering of the edges of the bright portion of the indicator shows the presence of noise interference. Telegraphic signals of slow speed will also affect the TUNING INDICATOR when they are c-w or tone-modulated c-w, since the indicator operates on carrier. However, high speed telegraphy may be too rapid for the tuning indicator circuit to follow.

(3) If the TUNING INDICATOR shows the presence of a signal by the closing of the circle but no sound is heard in the speaker or headset, you are picking up c-w. Switch the BEAT OSC. to ON; a whistle

should now be heard. Adjust the BEAT OSC. PITCH control to the note preferred and adjust the AUDIO GAIN to the desired volume.

(4) The BEAT OSC. may be used to search for signals, which will be indicated by a whistle for each station received. With the BEAT OSC. PITCH control set to its center position, you will be correctly tuned in when the beat note is low. Throw the BEAT OSC. switch to OFF and complete the tuning with the TUNING INDICATOR as in paragraph 12b(2). If the signal appears to be c-w, turn the BEAT OSC. switch on again and follow the instructions in the preceding paragraph.

(5) If there is a lot of noise, use the LIMITER. Adjust the control to position 1, 2, or 3 whichever gives the best results. The noise limiter is most useful on sharp noise pulses. On voice reception, position 3 may cut down the noise best but it often distorts the voice; if so, turn the LIMITER back to 2.

(6) When bothered by a hissing noise but no sharp pulses, use the AUDIO TONE control alone or with the LIMITER to get rid of the hiss. If there is no noise trouble, you'll get the clearest reception by leaving the AUDIO TONE knob all the way to the left.

(7) The CRYSTAL SELECTIVITY control will help get rid of interfering signals. Use position 2 for c-w signals; this position gives the best selectivity. Use position 1 for tone. Usually the CRYSTAL SELECTIVITY knob must be kept on OUT for voice reception because the tuning is too sharp. However, when you can't receive the signal because of channel interference, it may be picked up by turning the CRYSTAL SELECTIVITY knob to position 1 or 2 and at the same time turning the tuning dial slightly off resonance, away from the interfering signal.

(8) When tuning in a tone signal with the CRYSTAL SELECTIVITY control in position 1 or 2, you will find two points on the dial where the signal is loudest. These points correspond to the upper and lower modulation sidebands of the signal. The two peaks will be separated in frequency on the dial by twice the modulating frequency and the TUNING INDICATOR tune position will be half way between. This effect is present on all receivers but is noticeable only in those like the BC-969-A which combine the high selectivity in the crystal position with the tuning capability such that separate kilocycles may be discerned.

(9) Natural (thunderstorm) static will be noticed more on this receiver than on a high frequency receiver. Use the LIMITER to decrease the effect of this static.

AN OPERATIONAL CHECK PROCEDURE AND REMEDIES ARE GIVEN IN PARAGRAPHS 30 & 31. USE THESE TO FIND OUT IF YOUR SET IS WORKING OK.

RADIO OPERATOR: If you have learned to operate your set with good results and are interested in how it works, see SECTION III, FUNCTIONING OF PARTS.

REMEMBER THESE POINTS

1. Always find out what line voltage is available before you plug in the Power Supply Unit RA-61-A and see that the line voltage switch is set properly.
2. Be sure that Cord CD-872 is fastened securely to the receiver.
3. One and only one antenna plug is to be used. Make sure that the switch is in the proper position for the antenna you are using.
4. The HI-LOW power switch on top of the receiver chassis must always be on HI except when a telephone line is being used.
5. If your receiver doesn't work right, check it over carefully, using this manual—especially paragraphs 11, 12, 30, and 31.
6. Remember that there is bound to be more static on this receiver than on one which operates on higher frequencies.
7. Always disconnect the power unit from the line before opening either of the back doors as there are high voltages on the rear panel.
8. Always disconnect the set from the power line when changing fuses or tubes.
9. Don't let rain or water get into the set. While it is designed to withstand the effects of moisture, it should be kept as dry as possible.
10. The set is not difficult to operate if directions are followed carefully. Study this manual and you'll have no trouble at all.

SECTION III FUNCTIONING OF PARTS

	Paragraph
General circuit.....	13
Antenna circuit.....	14
Radio frequency amplifier.....	15
H-F oscillator.....	16
Converter.....	17
First i-f stage.....	18
Second i-f stage.....	19
Audio detector.....	20
Noise limiter.....	21
Audio frequency amplifier.....	22
Automatic volume control.....	23
Beat oscillator.....	24
Auxiliary diode circuit.....	25
Tuning indicator.....	26
Voltage regulator.....	27
Voltage supply.....	28
Power Supply Unit RA-61-A.....	29

13. GENERAL CIRCUIT.—Radio Receiver BC-969-A uses a super-heterodyne circuit. It has unusually high sensitivity for a receiver covering the frequency range of 15 to 150 kilocycles; it will pick up signals of the strength of 5 microvolts or less. Twelve-volt heater type tubes are used throughout. The filament and plate supply voltages are furnished by the separate Power Supply Unit RA-61-A, connected to the receiver by Cord CD-872. In the following circuit description the reference numbers, in parenthesis, are those appearing on the schematic circuit diagram, figure 12 and the simplified schematic circuit diagram, figure 13. These two diagrams, especially figure 13, should be referred to constantly along with this description.

14. ANTENNA CIRCUIT.—Connections for two types of antennas are provided, a 100 ohm balanced antenna by means of the dual contact connector (5), and a whip antenna or other similar low capacitance type by means of single contact connector (3).

a. 100 Ohm ant. circuit.—The 100 ohm impedance antenna is connected to the primary of the antenna transformer through the frequency band selector switch (6). Section (6-1) switches one side of the primary, and section (6-2) the other side of the primary. Both of these switches are on one switch wafer. This switch is shown in band 3 (highest frequency range, or 67.5 to 150 kilocycle) position. The antenna transformer assembly used for this range is that shown by (9); (8) is the transformer assembly for band 2, and (7) is the transformer assembly for band 1. Since each of these transformers is similar in function, a detailed description of only (9) will be given. Transformer assembly (9)

consists of the transformer (95), comprising primary and secondary coils with an electrostatic shield between them, trimmer (1-4), and temperature compensating capacitor (11-2). The secondary is tuned by section (15A) of the three-gang tuning capacitor (15). T' is tuning capacitor, (15A), is switched by section (6-3) of the band switch. In band 3 position, bands 1 and 2 secondaries are short circuited by extra switch contacts so that the lower frequency ranges cannot affect the operation of the higher frequency ranges by becoming resonant in one of the higher ranges due to distributed capacitance of the coils together with temperature compensators and trimmer capacitors.

(1) The primaries are critically coupled to the secondaries and with the secondary damped by resistor (14-5) provide an input impedance of 100 ohms on each of the three frequency bands.

(2) Transformer (93), (94), and (95) consist of multiple pie universal windings on a center core of high frequency compressed powdered iron and two enclosing shells of the same type iron. The entire transformer assembly for each frequency range is enclosed in a zinc shield can. The shield can is indicated on the schematic diagram by dotted lines and the transformer terminals, numbered from 1 to 6 are shown by small circles and the accompanying terminal number. These numbers on the diagram are the same as those on the terminal bases of the transformers in the receiver.

b. Whip antenna circuit.—When the whip antenna connection is used, the antenna circuit is capacitance coupled by means of antenna trimmer (1-1) to the high potential end of the secondary. Capacitor (1-1) is normally set to 10 micromicrofarads. Switch (2-1) is used to throw the capacitance coupling to receptacle (3) when the whip antenna is used and to ground when the 100 ohm antenna is used. When the 100 ohm antenna is used and switch (2-1) is in the 100 ohm position, capacitor (1-1) forms part of the trimmer capacitance across the secondary. By this means correct circuit alignment is provided for both antenna connections. Resistor (4) is a static drain to prevent accumulation of a static charge during thunderstorms or snow storms. Resistor (14-5) does not damp the secondary in WHIP position of switch (2-1). Capacitor (22-1) is a d-c isolating capacitor for the automatic volume control.

15. RADIO FREQUENCY AMPLIFIER.—The radio frequency amplifier tube (V_1) is a type 12SK7 having a cathode bias resistor (41-2) and cathode by-pass capacitor (16-1A). The screen voltage is supplied by the voltage divider system of resistors (18-1), (18-2) and (42-3) with screen by-pass capacitor (16-1B). In addition a small mica capacitor of 1000 micromicrofarads capacitance, (19-1), is connected from screen to ground. The function of this capacitor is to provide shielding between grid and plate leads at the base of the tube rather than any by-pass function. It is positioned across and close to the tube socket so that grid-plate capacitance coupling is prevented.

a. R-F transformers.—The radio frequency transformer system for each frequency band is in two coil cans, one comprising the primary and the other the mutual coupling and secondary. This is necessary because the high inductance required at those frequency ranges necessitates a separate primary coil. The primary is fixed tuned about 30% below the lowest frequency of each tuning range, thus providing a gain slope higher at the low frequency end to compensate for the reverse gain slope in the antenna stage. The overall r-f gain is consequently high and substantially flat throughout each frequency range. Primary tuning is provided by capacitors (20) and (31-15). Switching of the primary is accomplished by section (6-4) of the frequency band switch which short circuits all unused coils, and of the secondary by section (6-5) which short circuits the lower frequency unused coils. On bands 1 and 2, only mutual inductance coupling between primary and secondary is used but on band 3, additive capacitance coupling is provided by capacitor (29).

On band 2, where voice reception may be required, selectivity is decreased to the desired value by damping resistor (30). No damping is required on band 1 as selectivity on this band may be higher. On band 3, the selectivity is low enough so that no damping is required.

Capacitor (31-15) is placed across the primary to tune the primary to the desired fixed frequency below the low frequency end of the tuning range.

Adjustable air dielectric trimmers are provided on each band; these are shown at (1-5), (1-6), (1-7) respectively. Across each trimmer is a ceramic temperature compensating capacitor (11-3), (10-2), (10-3) respectively, to maintain resonance despite the change in inductance of the coils due to thermal expansion.

b. Decoupling Circuits.—In order to prevent interstage coupling through the common plate potential circuit, decoupling filters are provided in all amplifier stages. In the r-f stage there is a B plus capacitor (16-1C) and in addition resistor (21-1) and capacitor (12-2) provide effective decoupling.

c. Tuning Capacitor.—The tuning capacitor (15) has three sections; section (15B) tunes the secondary of the r-f transformer to resonance, section (15A) tunes the antenna stage, and (15C) the h-f oscillator

16. HIGH FREQUENCY OSCILLATOR.—The h-f oscillator circuit is of the cathode tap Hartley type for good frequency stability and uses a Type 12J5GT tube (V_3) which is enclosed in a metallic shield to prevent oscillator radiation from reaching the antenna. As a further aid to frequency stability the plate supply potential is regulated.

a. Oscillator Transformers.—The h-f oscillator transformer assembly for band 1 is shown at (90), band 2 at (91), and band 3 at (92).

Each assembly consists of a coil, (102), (103), and (104) respectively, with temperature compensating capacitors (35-1), (36) and (37-1), fixed trimmers (38), (39), and (31-3) and adjustable air trimmers (33-3), (33-4), and (33-5).

b. Series padder capacitors.—The series padder capacitors are outside the shield cans and on each band consist of a fixed position, (31-1), (32-1), and (31-2) respectively, and an adjustable air dielectric trimmer (34), (33-1), and (33-2).

c. Switching.—Switching to the three frequency bands is accomplished by sections (6-6), (6-7), and (6-8) of the frequency band switch, three sections being necessary because the relatively small size of the padder capacitors necessitates connecting the grid to the high potential side of the capacitor to avoid undue change in oscillator voltage with frequency. The grid capacitor is (32-2) and the grid resistor (42-1).

17. CONVERTER.—**a. Bias method.**—The converter tube (V_2) is a Type 12SA7 with cathode bias resistor (60) by-passed by capacitor (16-2C). The initial bias on this tube is approximately four volts which is higher than normal. This high bias is required so that grid current will not be drawn for any input signal as the overall r-f gain is in the neighborhood of 2000. If grid current occurs at any input the consequent harmonic production heterodyning with oscillator harmonics would cause spurious responses. A wire lead is connected from one diode plate of the 12SQ7 audio amplifier tube (V_8) to the grid of the 12SA7 converter tube (V_2) to prevent blocking of the converter tube during switching surges.

b. Oscillator injection.—The oscillator frequency voltage is applied to grid one of the converter tube through capacitor (22-2). The d-c circuit of this grid is completed by resistor (42-6).

c. Screen circuit.—Screen potential is derived from B plus through the two resistors (18-3) and (18-4) in parallel. The B plus by-pass is capacitor (16-2A) and the screen by-pass is (16-2B). Capacitor (19-2), by its type and physical placement, provides requisite grid-plate shielding.

d. First i-f transformer.—The intermediate frequency output of the converter is applied to the first i-f transformer which consists of a primary (43) and the mutual coupling and secondary (44), each with its associated trimmer capacitors and temperature compensators being enclosed in a separate shield can. The principal function of this i-f transformer is to prevent transmission of h-f oscillator energy through the i-f system with resultant overload of the i-f tubes and production of undesired bias voltage in the a.v.c. diode circuit. This problem does not exist in ordinary superheterodynes but because of the low signal frequencies covered by this receiver there is very little separation between the oscillator frequency and the intermediate frequency, particularly at

the low frequency end of the tuning range. The elimination of oscillator frequency energy is accomplished by two rejector circuits, one tuned 15 kilocycles higher and the other 30 kilocycles higher than the intermediate frequency. The intermediate frequency employed in the receiver is 455 kilocycles so the rejector circuits are tuned to 470 and 485 kilocycles respectively. In order to prevent interaction between the two rejector circuits, they are in separate shield cans.

The 485 kc rejector circuit consists of coil (105) and capacitors (33-6) and (37-2). This circuit is connected from converter plate to ground, thus providing a very low impedance path to ground for 485 kc oscillator energy which exists in the converter plate circuit. The entire primary circuit, which consists of the portion of the coupling coil between terminals (4) and (5) of transformer (44), coil (105), and capacitors (33-6) and (37-2), is tuned to 455 kilocycles so that energy of this frequency is transmitted through the mutual coupling to the secondary circuit. The entire secondary in can (44) is likewise tuned to 455 kilocycles but the portion comprising the iron core coil, and capacitors (37-3) and (33-7) is tuned to 470 kilocycles. This portion is connected in series between grid and cathode of the first i-f tube (V_4) thus providing rejection for 470 kc oscillator energy. Thus one rejector is effective when the receiver is tuned to the low frequency end of band 1 and the other when it is tuned to the high frequency end of band 1 and the low frequency end of band 2. Throughout the rest of the receiver tuning range the normal i-f selectivity serves to prevent transmission of h-f oscillator energy through the i-f system. No adjustment of the rejector circuits is provided other than the trimmers which tune the entire circuit, the rejector portion inductance being so proportioned to the entire circuit inductance that desired rejection and i-f resonance are obtained simultaneously. In order to obtain rejection, the converter plate and the first i-f grid are each tapped across only a small portion of the total circuit inductance, consequently the gain of this stage is low, only about 1.5.

18. FIRST I-F STAGE.—a. First i-f tube.—The first i-f tube (V_4) is a type 12SK7, having a cathode bias resistor (21-6). This resistor is not by-passed in order to provide degeneration to limit the i-f gain, since only low gain is desired in the i-f, and to provide greater overload capabilities in this stage.

Screen potential is supplied by a voltage divider network consisting of resistors (18-6) and (42-7). Screen by-passing is by capacitor (47) and grid-plate shielding is provided by capacitor (19-3).

b. Crystal filter circuit.—The output of the first i-f tube is fed into the primary of transformer (51) thence to the secondary and, after passing through the filter crystal (53), to transformer assembly (54). Transformer (54) and the primary circuit of transformer (51) are each provided with trimmer capacitors (49-2B) and (49-1A) respectively and two fixed tuning capacitors (50-2), (31-7) and (31-4), (31-5) respectively.

The crystal filter circuit proper is of the bridge type, the secondary of i-f transformer (51) feeding energy across one pair of bridge diagonals. One pair of bridge arms is comprised of capacitors (51-1) and (49-1B) in parallel and capacitor (31-6). The center of this pair of bridge arms is at ground potential and capacitor (49-1B) is an adjustable trimmer so that the two arms of the bridge may be balanced. The other pair of bridge arms is comprised of the crystal (53) and the phase adjustment trimmer (49-2A) in series with capacitor (11-4). The junction of these two arms is connected to the high potential end of transformer assembly (54) and thence to the grid of the second i-f tube. The crystal selectivity is adjusted by means of switch (52). On OUT, the crystal (53) is short circuited and normal i-f selectivity is obtained. On position 1, the crystal filter adds to the i-f selectivity. Still greater selectivity is obtained by throwing switch (52) to position 2. Resistor (13-3) is then across coil (108) and provides greater selectivity. In position 1, no resistance is across coil (108). This condition of having greatest selectivity when a resistance is shunted across the tuned circuit of transformer (54) is due to the property of crystal filters in which an inductance acts to increase the crystal filter band width. In the higher selectivity, position 2, the effect of coil (108) is decreased by the resistor (13-3) and thus selectivity is enhanced.

19. SECOND I-F STAGE.—The second i-f stage consists of a 12SK7 tube (V_5) and acts as the driver for the two 12H6 diode tubes through the medium of transformer assembly (61). Screen potential for this 12SK7 tube is obtained by dropping resistor (18-7) and is by-passed by capacitor (16-3B). Capacitor (19-4) functions as a grid-plate shield. The bias for the tube is by means of resistor (48) which is by-passed by capacitor (12-13). Since only low i-f gain is required, the capacitance in the circuits of transformer (61) is large, thus providing low impedance.

The suppressor grid of the second i-f tube is connected to ground through the b-f oscillator coil to permit beat oscillator energy to be applied to this tube.

Within the shield can of transformer assembly (61) are included portions of the diode circuits fed from that transformer in order to confine high r-f potentials within this shield. The tuned circuits of transformer (61) comprise coils (110) with fixed capacitors (31-8) and (31-9) and trimmer (49-3A) across the primary; fixed capacitors (31-10) and (31-11) and trimmer (49-3B) across the secondary.

20. AUDIO DETECTOR.—The audio detector consists of the upper portion of the upper 12H6 tube (V_6) on the schematic diagram (figure 12) together with load resistors (59-2) and (13-4) and capacitor (32-5). The audio frequency energy is taken off at the junction point of resistors (59-2) and (13-4).

21. NOISE LIMITER.—The noise limiter consists of the lower portion of the 12H6 tube (V_6). A LIMITER knob is provided on the receiver front panel for control of the degree of limiting. When this knob is at OFF, the limiter diode is short circuited and no limiting occurs. In other positions, the audio energy from the audio detector is fed to the first audio frequency amplifier through the noise limiter diode. The limiter diode plate is connected to the junction of resistors (59-2) and (13-4) and since these resistors carry direct current by virtue of signal rectification in the detector diode, the d-c potential of the plate is governed by the ratio of these two resistance values. In position 1 of the LIMITER, resistor (13-4) only is connected from noise diode plate to ground. In positions 2 and 3, resistors (59-1) and (64) respectively are connected in shunt to resistor (13-4) changing the noise diode plate potential and thus the limiter threshold. The cathode potential of the noise diode is derived from resistors (62) and (14-3). Capacitor (31-13) acts merely as an r-f by-pass. In the absence of noise, the relative potentials of plate and cathode of the noise diode are such that conduction takes place, the diode resistance is low and the detected signal energy is applied through the diode path to the first a-f amplifier. When a noise pulse occurs the detector d-c voltage rises, the noise diode plate potential becomes more negative and the noise diode resistance increases to limit the noise to approximately the peak modulated-signal level. In order that change in signal level does not cause limiting, resistors (62) and (14-2) change the cathode potential as resistors (59-2) and (13-4) change the plate potential. Resistor (62) and capacitor (16-3C), however, have a time constant of approximately 0.1 second and, since noise is usually of a sharp peak nature, the potential of the cathode is held constant during the noise pulse, and limiting occurs. This time constant circuit thus permits the noise diode to assume a conducting condition for all signal levels but does not permit rapid change in cathode potential and hence gives limiting on sharp pulses. For this reason the type of noise limiter used in this receiver is most effective on sharp noise pulses.

22. AUDIO FREQUENCY AMPLIFIER.—**a. First a-f amplifier.**
—The audio frequency output from the detector is fed through coupling capacitor (71-1) to the high potential end of the AUDIO GAIN control (72). From here the signal goes to the grid of the first a-f tube (V_8) which is a type 12SQ7. This tube is self biased by resistor (73); capacitor (74-1) is the bias by-pass. The plate load resistor is (13-2) and capacitor (31-14) serves to by-pass any r-f energy which may exist in the first a-f stage. Resistor (14-6) is inserted at the grid of the first a-f amplifier (V_8) to prevent possibility of feed back of r-f energy through the lead from the diode of (V_8) to the grid of the converter (V_2). One diode of the 12SQ7 is connected to the grid of the converter tube to prevent blocking of the converter tube during switching surges. The other diode plate is grounded to prevent hum pickup.

b. A-F output stage.—The a-f signal, amplified by the first a-f stage, is coupled through capacitor (71-2) to the grid of the 12A6 output amplifier (V_9). Capacitor (70-2) and variable resistor (75) comprise the AUDIO TONE control system. Switch (2-3) provides HI and LOW output control. On HI, the undistorted power output of the receiver is 2.0 watts for any of the output impedances and the maximum output is approximately 3.0 watts. The low output is used only when a telephone line is connected to the receiver output to supply audio signal to some remote point. When the switch is on LOW, it prevents overloading of the telephone line in case the operator should unintentionally turn up the volume. When switch (2-3) is on HI, the 12A6 is self-biased by resistor (77) and degeneration is prevented by by-pass capacitor (74-2). When on LOW, resistor (40) provides degenerative bias to limit the output to about 50 milliwatts maximum.

c. A-F output filter.—Since the lower end of the reception range of Radio Receiver BC-969-A is near the upper end of the audio frequency range, namely, 15 kilocycles, and since the total gain through the receiver is of the order of 30 million times in the 4000-ohm output impedance connection, special precautions are necessary to prevent feedback from the output to the input of the receiver. A low-pass filter consisting of capacitors (78-1) and (78-2) and inductance (79) provides transmission for audio frequencies up to 5000 cycles but attenuates frequencies above this value, the attenuation at 10,000 cycles being about 30 decibels. The filter has a characteristic impedance of 7500 ohms, the desired load impedance for the 12A6 tube.

d. Output transformer.—Output transformer (80) is used to provide the desired output impedance while presenting to the 12A6 tube (V_9) the correct load impedance. It provides impedance of 250 OHMS to GROUND, 4000 OHMS to GROUND, and 250 OHMS balanced to ground on the screw type terminals of the OUTPUT terminal panel at the rear of the receiver. The winding providing 250 OHMS to GROUND also connects to the OUTPUT jack (81) on the receiver's front panel. The output transformer is fully shielded and has an electrostatic shield between primary and secondary windings.

23. AUTOMATIC VOLUME CONTROL.—The receiver is provided with automatic volume control derived by rectification of signal energy in the upper portion of the 12H6 diode (V_7) on the schematic diagram (figure 12). The a.v.c diode is fed from the primary of transformer (61) through coupling capacitor (32-4). Resistor (14-1) comprises the diode load and resistor (14-2) and capacitor (70-1) provide the first stage of filtration to eliminate any r-f energy in the a.v.c. system. The cathode of the a.v.c. diode is above ground by reason of resistors (21-5) and (69), thus delaying a.v.c. action until about 100 microvolts input signal is reached, insuring high sensitivity for low signal values. The i-f path through the diode is completed to ground by capacitor (12-9). The

a.v.c. voltage is fed to the r-f tube by the filter consisting of resistor (13-1) and capacitor (12-1). A.V.C. voltage is applied to the r-f tube only to prevent converter overload. For successful operation of the receiver and for high sensitivity unusually high r-f gain has been provided. If automatic volume control is used on the i-f tubes, less a.v.c. voltage is developed for a given signal input and overload of the converter occurs at high signal levels. This necessity for high a.v.c. level on the r-f tube only does not give as flat a.v.c. action as when more tubes are controlled but gives better overall operation since it prevents spurious responses, distortion, and decrease in output which occur if the peak signal on the converter grid is allowed to exceed the d-c grid voltage on this tube at any signal level.

24. BEAT OSCILLATOR.—The beat frequency oscillator tube (V_{10}) is a 12J5GT and is used in a Hartley circuit. The beat oscillator transformer (55) has an adjustable iron core for setting the frequency to the i-f value of 455 kilocycles when the BEAT OSC. PITCH capacitor (57) is set at midvalue. The main tank capacitor (56) is of 1000 micromicrofarad capacitance, thus providing a high degree of frequency stability against capacitance changes elsewhere in the circuit. Capacitor (35-2) is a temperature compensator. The cathode tap connection applies beat oscillator output to the suppressor of the last i-f tube. The heater circuit of the beat oscillator is continuously energized. The beat oscillator is controlled by the BEAT OSC. OFF-ON switch (2-2). Resistor (42-2) is the plate isolating resistor and capacitor (12-7) the plate by-pass. The grid capacitor is (32-3) and the grid resistor (18-8).

25. AUXILIARY DIODE CIRCUIT.—The lower portion of the lower 12H6 tube (V_7) on the schematic diagram (figure 12) is used as an auxiliary diode. It is coupled to the plate circuit of the last i-f stage by capacitor (31-12), and provides both positive and negative polarity at the AUXILIARY DIODE terminals at the rear of the receiver. Resistor (42-4) provides an r-f impedance and with capacitor (22-3) provides r-f filtering for terminal (66). Filtering in the other leg of the circuit is provided by resistor (42-5) and capacitor (22-4) for positive terminal (68). The time constant of the circuit is of the order of 100 microseconds so that the modulation envelope is reproduced faithfully at terminals (66) and (68). In order to use the auxiliary diode output, it is necessary to complete the d-c path from negative terminal (66) to ground terminal (67) and from positive terminal (68) to ground. The auxiliary diode output is used for direction finding purposes only when certain direction finding equipments are available. Complete instructions for this application are supplied with the direction finding equipment for which this

output was specifically designed. These terminals are useful also for receiver alignment with a d-c milliammeter. In this case one side may be short circuited and the milliammeter connected to the other pair of terminals. The use of a milliammeter is virtually necessary for alignment of the crystal filter as that circuit is sharper than the modulation of a modulated wave. These terminals may also be used to connect a milliammeter for indication of signal intensity.

26. TUNING INDICATOR.—The tuning indicator (V_{11}) is of the electron ray type using a type 1629 tube. The d-c voltage for this tube is supplied by the detector diode through the filter comprising resistor (58-1) and capacitor (16-3A). Resistor (65) with (58-1) in series as a voltage divider and cathode resistor (41-1) give tuning indication over the entire signal range from 10 microvolts to 100,000 microvolts. Resistor (58-2) is the load resistor for the 1629.

27. VOLTAGE REGULATOR.—A regulated voltage of 150 volts is provided for the plate supply of the high frequency and beat frequency oscillators, thereby stabilizing the frequency of these oscillators regardless of line voltage changes. This regulation is provided by resistor (45) and the VR 150-30 tube (V_{12}). At normal 250 volt plate supply voltage the VR 150-30 tube draws about 20 milliamperes; with higher plate supply voltage, the current through this tube increases, and with lower plate supply voltage, the current decreases, thus maintaining the voltage at the low potential end of resistor (45) substantially constant.

28. VOLTAGE SUPPLY.—The voltages derived from Power Supply Unit RA-61-A are applied to the receiver through receptacle (89). This receptacle also connects the POWER ON-OFF switch (76) to the power supply unit. Capacitors (12-10), (12-11), (12-12), and (12-3) are all connected close to the receptacle to prevent any r-f energy which might exist in the power supply unit circuits from entering the receiver. The letter symbols on receptacle (89) correspond to letter symbols on the plug of the power unit to which they connect. The filament circuit designated X and Y on the schematic diagram, is a two wire system throughout the chassis with the X side, distinguished by the black color coded wire in the chassis, grounded near each socket. The dial lights (112-1) and (112-2) are 6-8 volt lamps and are supplied through resistors (87-1) and (87-2) to have a normal operating potential of 6 volts.

29. POWER SUPPLY UNIT RA-61-A. — Power Supply Unit RA-61-A (figure 6) is a single tube full-wave rectifier used to supply d-c voltage. The 60-cycle input voltage is applied to the primary of the transformer (204) by means of Cord CD-873, through switch (201) which

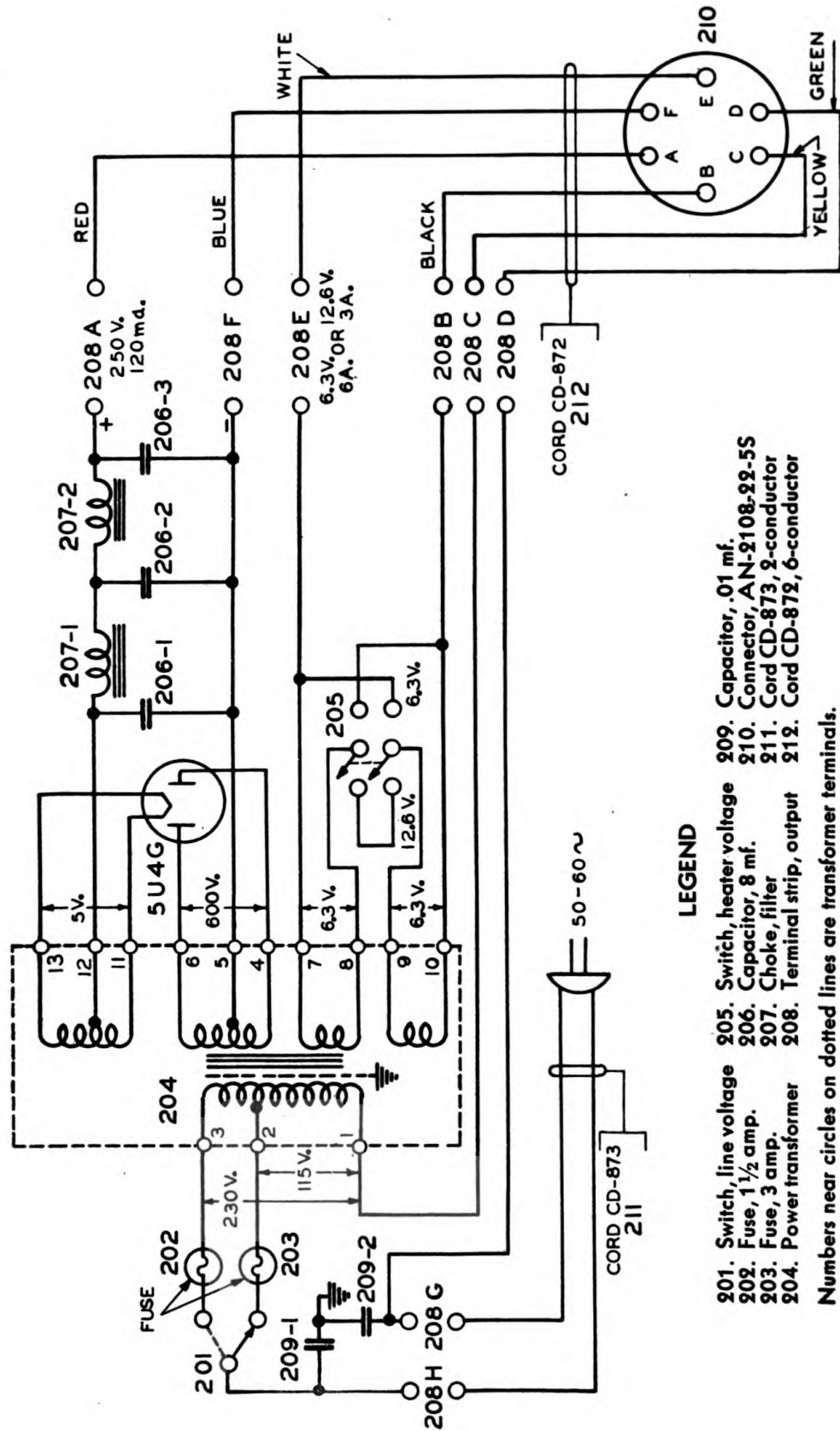

Figure 6. Power Supply Unit RA-61-A, schematic circuit diagram

LEGEND

- 201. Switch, line voltage
- 202. Fuse, 1 1/2 amp.
- 203. Fuse, 3 amp.
- 204. Power transformer
- 205. Switch, heater voltage
- 206. Capacitor, 8 mf.
- 207. Choke, filter
- 208. Terminal strip, output
- 209. Capacitor, .01 mf.
- 210. Connector, AN-2108-22-55
- 211. Cord CD-873, 2-conductor
- 212. Terminal strip, output
- 213. Cord CD-872, 6-conductor

Numbers near circles on dotted lines are transformer terminals.

can be set for 115 or 230 volts and through either fuse (202) or (203). The transformer has an electrostatic shield to prevent radio frequencies on the power supply line from being transmitted through the power unit. Voltage will not be applied to the transformer until the POWER switch on the receiver is turned on. Capacitors (209-1) and (209-2) are used to by-pass to ground any radio frequency energy present on the a-c power line. The secondary of the transformer has four windings. Winding one supplies 5 volts to the filament of the 5U4G tube. Winding two is a high voltage winding which steps up the line voltage to about 600 volts. This voltage is applied to the plates of the 5U4G tube; rectified by the tube, and filtered by capacitors (206-1), (206-2), (206-3), and inductors (207-1), (207-2). The resulting d-c voltage, (250 volts at 120 milliamperes), is applied to the receiver through Cord CD-872 (212). Transformer windings three and four each supply 6.3 volts. By means of switch (205), these two windings can be connected in series to supply 12.6 volts or they may be connected in parallel to supply 6.3 volts. This a-c voltage also is applied to the receiver through Cord CD-872.

SECTION IV MAINTENANCE

	Paragraph
Operational check in field.....	30
Field upkeep.....	31
Trouble location and remedy chart.....	32
Alignment procedure.....	33
Disassembly and reassembly of front panel and dial assembly.....	34
Replacement of crystal filter, switch and socket.....	35
Replacement of fixed capacitors.....	36
Replacement of band switch and limiter switch.....	37
Replacement of transformers.....	38
Replacement of gang capacitor.....	39
Replacing tube sockets.....	40
Servicing Power Supply Unit RA-61-A.....	41
Performance characteristics.....	42
Moisture Proofing.....	43

30. OPERATIONAL CHECK IN FIELD.—a. If the pilot lights light up when the receiver is turned on, it indicates that there is a connection between the power supply unit and the receiver, that no fuses are burned out, and that the power unit is connected to a source of electric power. If the pilot lights do not light up, see paragraph 31a for correction.

b. After the receiver has been turned on for about a minute, look at the TUNING INDICATOR to see if it has a green florescent glow. The glow shows that the power unit is supplying high voltage d-c. If no glow appears, see paragraph 31b.

c. Look at the TUNING INDICATOR and turn the TUNING knob. A fluctuation of the edges of the shadow in the TUNING INDICATOR indicates the presence of external noise or signal. Test on all three frequency bands by turning the FREQ. BAND knob. If no fluctuation occurs, see paragraph 31c(1) & (4).

d. Turn the BEAT OSC. switch to ON. If there is an increase in hiss or if a whistle is heard in the headphones or speaker as the tuning dial is turned, the beat oscillator is working satisfactorily. If it is not working properly, see paragraph 31c(1) & (2).

e. Turn the AUDIO TONE and AUDIO GAIN knobs back and forth. If the tone changes and the volume of hiss increases or decreases, it indicates that the tone and volume controls are working properly. If there is no change, see paragraph 31c(1) & (3).

f. Turn the LIMITER knob through the different positions. If the noise is loudest when it is OFF but decreases more and more in positions 1, 2, and 3, the noise limiter is operating properly. If the noise does not decrease in the various positions, see paragraph 31c(1) & (5).

31. FIELD UPKEEP.—a. Checking pilot lamps.—(1) When the receiver is turned on, see if the pilot lights are lit. If not, remove the escutcheon (157) from the front panel (figure 3) by unscrewing the four thumb screws, and replace the bulbs. (A screwdriver or a dime may be used to loosen the thumb screws if they are too tight to loosen with the fingers.) To remove the bulb, press down and turn one-quarter turn to the left and lift out. To insert new bulb, drop bulb in socket, press down and turn one-quarter turn to the right.

(2) If the pilot lights still do not light, check the cable connections between the power unit and the receiver. The cable connections are located on the back of the receiver chassis. These must make a good connection to the receiver. There is a guide pin which allows the cable to be replaced in only one position and a threaded sleeve that should be screwed tight to make a secure and positive contact.

NOTE: When the receiver is mounted in Radio Direction Finder Central TC8 or Radio Intercept Central TC9, remove the receiver from the mounting to examine the connections. To do this, unfasten the trunk latches on the sides of the receiver and slide it off of Mounting FT-411-A.

(3) If the connection is secure and the pilot lights still are off, check the power unit. Make sure there is a good connection to the power line. Be sure the line voltage switch is in the proper position, i.e., 115 V. or 230 V. Check to see that the heater switch is in the proper

position, i.e., 12.6 V., for this receiver. Check the fuses to see if they are burned out.

CAUTION: DO NOT REMOVE FUSES WHILE THE POWER SUPPLY UNIT IS CONNECTED TO THE POWER LINE OR YOU MAY GET A DANGEROUS ELECTRIC SHOCK.

To remove the fuse, turn the fuse cap ($1\frac{1}{2}$ Amp. for 230 V. or 3 Amp. for 115 V.) one-quarter turn to the left and lift out. Examine the fuse; if the thin wire through the center is broken, the fuse is burned out. If it is burned out, replace it with a spare found inside the left cover in the back of the power supply unit. Be sure you use a fuse of the right value as mentioned earlier in this paragraph. Reinsert the fuse and fuse cap and turn the cap one-quarter turn to the right. Close the covers and reconnect the power unit to the power line.

b. Checking the tuning indicator.—After the receiver has been turned on for about a minute, a bright green florescent glow should appear on the face of the TUNING INDICATOR. If the TUNING INDICATOR does not glow, check the rectifier tube (5U4G). (This tube is located under the right cover in the back of the power unit and on the right side of the compartment.) See if the heaters are lighted. If not, replace the tube with the SPARE found alongside of the one in use. Make sure the tube is securely seated in its socket.

WARNING: DISCONNECT THE POWER SUPPLY UNIT CORD FROM THE POWER LINE WHEN CHANGING THE TUBE.

After making the above checks, if signals are being heard in the headset or speaker, and the TUNING INDICATOR still does not glow, replace it with a new tube from the spare tube kit. To replace this tube, lift the receiver case lid, loosen the screw under the bracket and pull the tube and clamp free from the bracket. Remove the tube from the cable and the clamp from the tube. Put the clamp on the new tube, seat the tube securely in the cable socket and put the tube back in the bracket. Make sure the tube is resting firmly against the rubber grommet on the front panel, then tighten the screw and clamp securely to the bracket.

c. Checking receiving tubes.—(1) To check the receiving tubes, it will be necessary to have the receiver case free in order to lift the cover. See NOTE in paragraph 31a(2).

(2) To check the beat oscillator tube (V_{10}) (figure 9), remove the tube shield; unscrew the two thumb screws and lift the shield off of its spacers. Look at the tube to see if the heaters are lighted. (Make sure the tube is firmly seated in its socket.) If the heaters aren't lighted, replace the tube from the spare tube kit. If the heaters are lighted and no whistle or increased hiss is heard when the BEAT OSC. PITCH knob is turned, check the VR 150-30 (V_{12}) tube. See if there is a purple glow

in this tube; if not, replace it with a new one. Be sure to put the tube shield back on the beat oscillator tube and screw in the thumb screws.

(3) If the circle of the TUNING INDICATOR closes, showing that a signal is present but it is not heard in the headset or speaker, check the 12SQ7 (V_8) and 12A6 (V_9) audio amplifier tubes. Make sure that the AUDIO GAIN is turned up and that the tubes are firmly seated in their sockets. Feel the tubes to see if they are hot. If cold, replace them from the spare tube kit. If both tubes are hot and still no signal is heard, it will be necessary to replace each tube in turn to eliminate the defective one. If you still can't hear the signal, check the headset and speaker connections.

NOTE: Be careful when feeling metal tubes as they become quite hot.

(4) If there is no fluctuation in the shadow of the TUNING INDICATOR any of the following tubes may be defective: the 12SK7 r-f amplifier tube (V_1), the 12SA7 converter tube (V_2), the 12J5GT h-f oscillator tube (V_3), the two 12SK7 i-f amplifier tubes (V_4) and (V_5), the 12H6 detector-noise limiter tube (V_6), or a combination of two or more of these tubes. Make sure all tubes are firmly seated in their sockets. Take the shield can off the 12J5GT h-f oscillator tube (V_3) by removing the two thumb screws and lifting the can off of the shield spacers. Look at the heater to see if it is lighted. If not, replace the tube from the spare kit. If it is lighted, feel the metal tubes to see if they are hot. (**Be careful you don't burn your fingers.**) If one or more of them are cool after the receiver has been turned on for a few minutes, replace them with new tubes. (If a tube remains cold, it is probably burned out.) If all the tubes are warm and still no signal is received, replace each tube in turn until the defective tube has been located and replaced. If no defective tubes are found, then check the antenna input connection to make sure it is secure.

(5) If the LIMITER does not work, check the 12H6 detector-noise limiter tube (V_6). Be sure it is securely seated in the socket. If the tube is cool, replace it. If the tube is hot but no change is heard in the intensity of the noise when the LIMITER knob is turned back and forth, replace the tube from the spare kit.

d. Do not attempt additional servicing in the field beyond the replacing of tubes, fuses, and checking of connections, since the necessary test equipment and replaceable parts are usually not available. If, after making the necessary checks and substitutions as outlined in the foregoing paragraphs, the receiver still does not operate satisfactorily, replace it or send it to a repair base equipped for more detailed servicing.

e. Keep the tuning capacitor gear drive assembly free of sand and dirt. Lubricate occasionally with cold weather machine gun grease, such

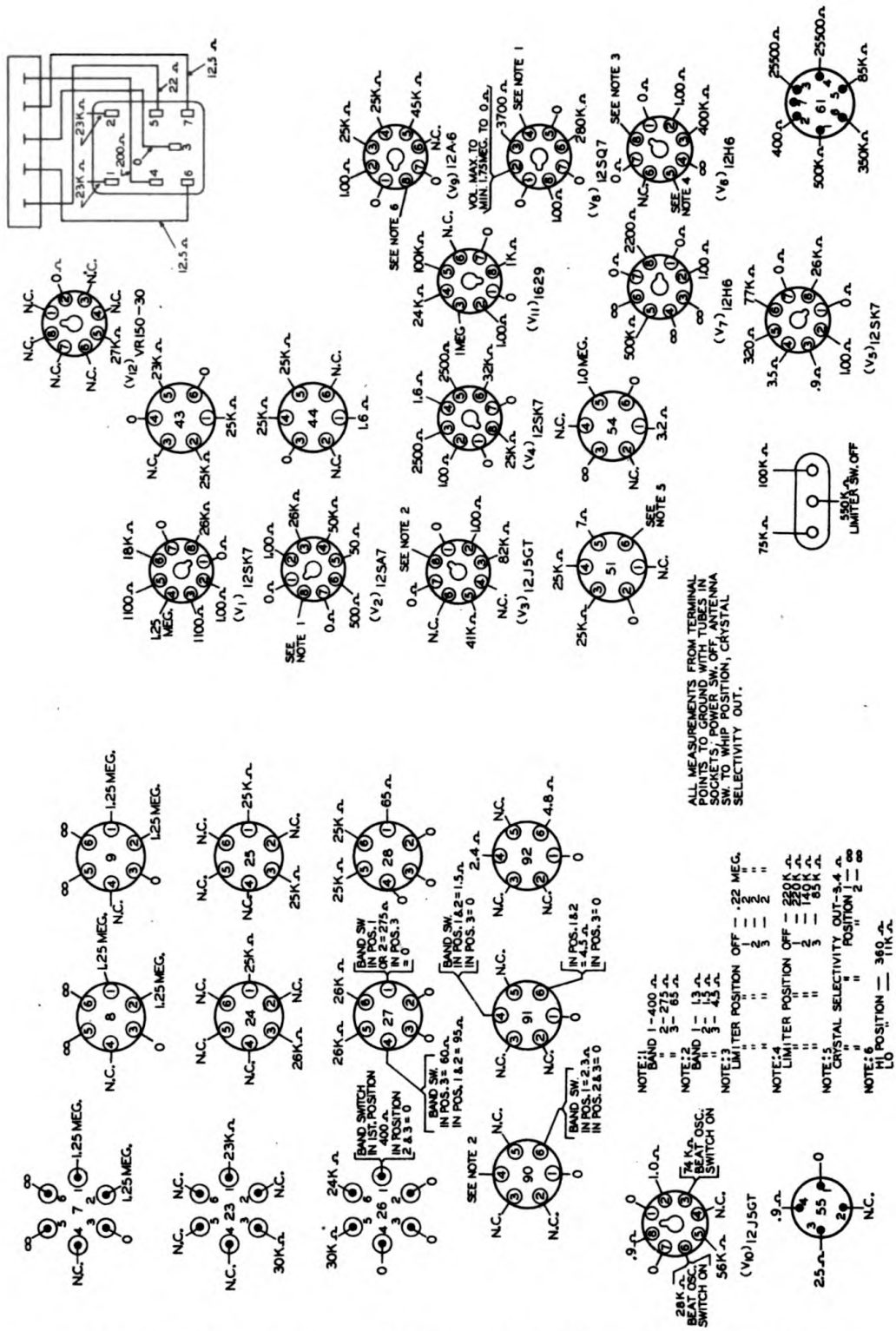

Figure 7. Radio Receiver BC-969-A, tube sockets and transformers, resistance diagram, bottom view of chassis

Generated on 2015-10-01 04:47 GMT / http://hdl.handle.net/2027/uc1.b3243881
 Public Domain, Google-digitized / http://www.hathitrust.org/access_use#pd-google

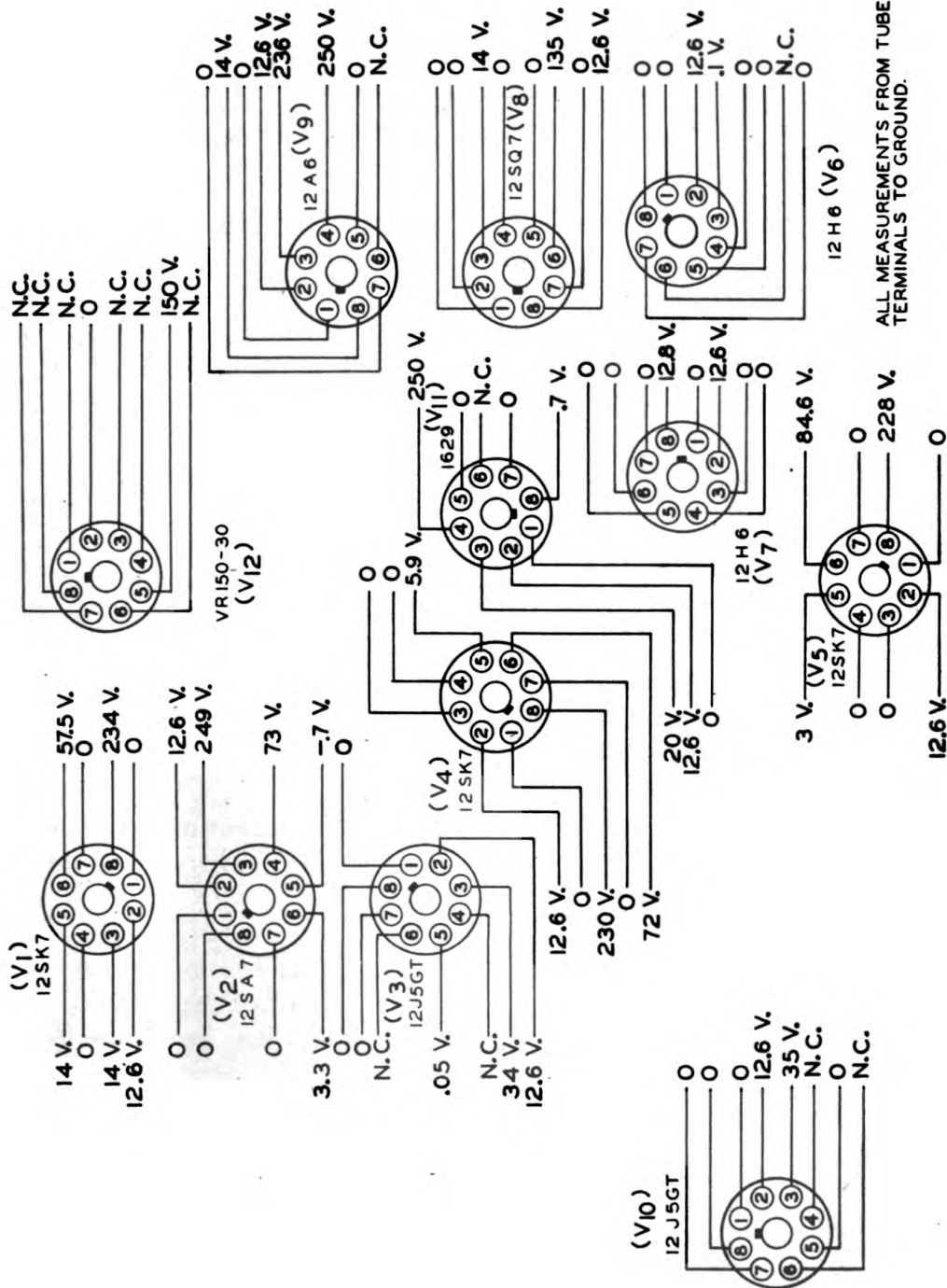

Figure 8. Radio Receiver BC-969-A, tube socket voltage diagram, bottom view of chassis

as special lubrication grease AXS637, or when this is not available, with a light grease. Do not use oil. Keep the dial screws tight as well as all other screws and nuts which may be reached easily with a screwdriver and a pair of pliers.

WARNING: DO NOT ATTEMPT TO CHANGE THE ALIGNMENT OF THE R-F OR I-F TRANSFORMERS IN THE FIELD. SPECIAL TEST EQUIPMENT IS NEEDED TO DO THIS WORK.

32. TROUBLE LOCATION AND REMEDY CHART.—

Trouble	Possible Causes	Remedy
Receiver will not light up when POWER switch is turned on.	Poor connection to power line.	Make secure connection to the power line.
	Pilot lights burned out.	Replace burned out lamps.
	Poor connection between receiver and power supply.	Check cable connection. See paragraph 31a(2).
	Defective POWER ON-OFF switch.	Replace switch.
Motorboating.	Open grid connection.	Check continuity of the grid circuits. See figure 7.
Overloading.	A.V.C. short.	Check continuity of grid circuit of the r-f amplifier tube. See figure 7.
Distortion.	Improper grid bias.	Check cathode circuits in the audio section for defective resistors. Look for shorted audio bypass capacitor.
	Leaky coupling capacitor.	Replace capacitors 70-1 and 70-2.
No signal.	Shorted B+ in receiver	Check for shorted bypass capacitor or shorted leads.

Trouble	Possible Causes	Remedy
No signal— cont'd.	Open connection or part.	Isolate the defective section, using a signal generator and output indicator and check for open circuits in the defective section.
	Shorted B+ in power supply unit.	Check for shorted filter capacitor or crossed wires.
	Defective or burned out tube.	Replace tube.
	Open B+ connection in receiver.	Check plate and screen voltages. See figure 8.
	Defective cable from power unit to receiver.	Replace cable.
	Shorted by-pass capacitor.	Check for shorted by-pass capacitor. See figure 7.
	Headset plug not fully inserted in jack.	Push plug securely into jack.
	Headset open at plug.	Repair plug connections.
	ANTENNA switch in 100 Ohm position when using WHIP.	Change switch to WHIP position.
	Antenna connections shorted.	Remove short.
Weak signal.	Out of alignment.	Realign. See paragraph 33.
	Defective tube.	Replace tube.
	Antenna insulation shorted by water or dirt.	Clean insulation on antenna connections.

Trouble	Possible Causes	Remedy
<p>Weak signal— cont'd.</p>	<p>Low B+.</p>	<p>Check the line voltage to see if it is low.</p> <p>Check for a leaky filter capacitor in the power supply unit.</p> <p>Check to see if the input filter capacitor in the power unit is open.</p> <p>Check for high resistance short in by-pass capacitors in receiver.</p>
	<p>Shorted by-pass capacitor other than B+.</p>	<p>Check cathode and screen by-pass capacitors for short circuits.</p>
	<p>Poor antenna connection.</p>	<p>Check antenna connections.</p>
	<p>Antenna switch in WHIP position when using 100 Ohm antenna.</p>	<p>Change ANTENNA switch to 100 Ohm position.</p>
	<p>Improper grid bias.</p>	<p>Check for defective cathode resistors and shorted by-pass capacitors in the r-f and i-f circuits. See figure 12.</p>
	<p>Leaky coupling capacitor.</p>	<p>See "Distortion."</p>

33. ALIGNMENT PROCEDURE.—Align or check the alignment of the i-f stages before aligning the r-f stages of Radio Receiver BC-969-A. All variable trimmer and padder capacitors are provided with a lock nut which must be loosened for alignment and **tightened when the alignment has been completed.** The variable trimmer capacitors are adjusted from the top of the i-f and r-f transformers. Two padder capacitors, (33-1) and (33-2) (figure 14), are mounted on the bottom of the chassis and one, (34) is mounted to the side of the chassis. The padders are adjusted from the top and side of the chassis. A signal generator,

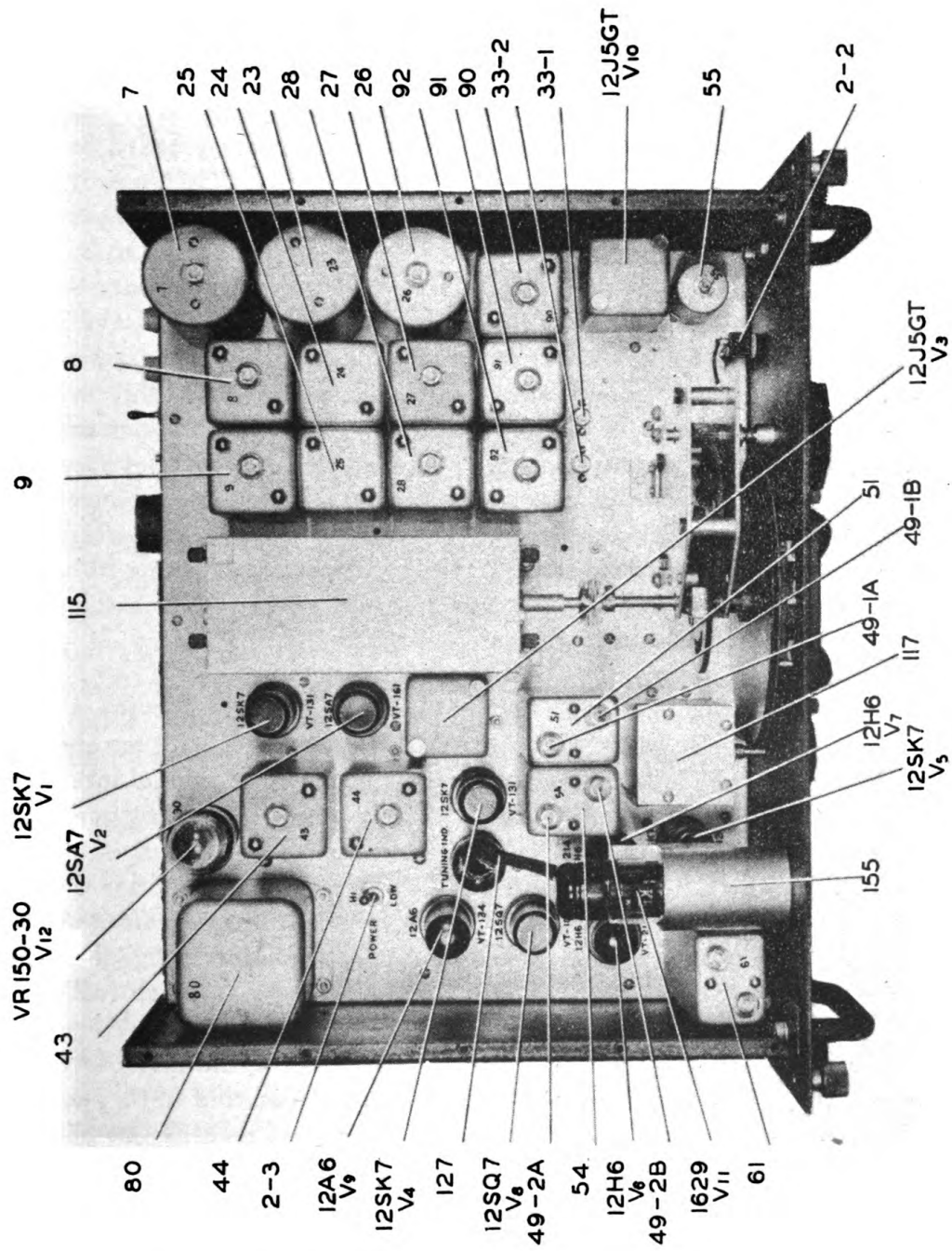

Figure 9. Radio Receiver BC-969-A, top view

which has a frequency range of 15 to 150 kilocycles and a frequency range of 450 to 490 kilocycles, and two output indicators are needed to align the receiver. The output indicators required are: a sensitive d-c meter whose range does not exceed 1 milliampere, and an output or a-c rectifier type meter.

a. Alignment of i-f stages.—(1) Connect the output or a-c type rectifier meter to the terminals on the output terminal board on the back of the chassis (figure 2). If an impedance match (250 ohms output on output terminal board to 250 ohms input to output meter or 4000 ohms output on output terminal board to 4000 ohms input to output meter) (figure 2) is available, use it. If not, it may be necessary to try both the 250 and 4000 OHMS to GROUND terminals to get the most satisfactory variation of output signal. Connect the ground lead of the signal generator to a ground point on the chassis and the other lead to the grid, terminal No. 8, of the 12SA7 converter tube. If you have trouble connecting the lead to the grid lug on the tube socket without shorting other lugs, you can connect to the grid indirectly as follows: Connect the "hot" lead of the signal generator to the terminal with a single green and white wire lead on the third wafer of the band switch, counting from the knob. This wire goes to the gang capacitor and a green lead on the gang capacitor goes to the grid of the converter tube.

(2) Turn on the signal generator and receiver. Set the signal generator to 455 kilocycles. Turn the AUDIO GAIN control far enough to the right to note a distinct change of output when the signal intensity of the generator is changed. BE CAREFUL that you do not overload the output meter. MAKE SURE the signal of the generator is modulated. Turn the CRYSTAL SELECTIVITY switch to position 2 and readjust the signal generator at 455 kilocycles until a maximum signal is noted in the output meter. When you have a maximum signal in the output indicator, turn the CRYSTAL SELECTIVITY switch to OUT.

(3) Loosen the lock nuts on the trimmers of the last i-f transformer, (61) (figure 9). Adjust both trimmer capacitors until you get the maximum output signal. Set the lock nuts and recheck the output signal strength to see whether or not it was changed by "locking" the trimmers.

(4) Connect the negative and positive leads of the d-c meter to the GROUND and + (plus) terminals respectively, of the AUXILIARY DIODE terminal board on the back of the chassis (figure 2). Connect a shunt between the - (minus) and GROUND terminals. Turn off the signal generator modulation and, if necessary, cut down the output signal intensity from the generator so as not to overload the meter. Turn the CRYSTAL SELECTIVITY switch to position 3. Adjust trimmer (49-2B) (figure 9) of transformer (54) to maximum as indicated by the

d-c meter. Similarly, adjust trimmer (49-1A) of transformer (51) for a maximum deflection on the meter.

WARNING: TRIMMER (49-1B) SHOULD NEVER NEED ADJUSTMENT EXCEPT IN CASE OF ACCIDENTAL DAMAGE TO THE TRANSFORMER, IN WHICH CASE IT MAY BE ADJUSTED ON A CAPACITANCE BRIDGE SO THAT THE SUM OF THE CAPACITANCES (49-1B) AND (50-1) IS THE SAME AS CAPACITANCE (31-6). (SEE SCHEMATIC CIRCUIT DIAGRAM, FIGURE 12). DO NOT TRY TO MAKE THIS ADJUSTMENT WITHOUT SUCH A BRIDGE.

Adjust capacitor (49-2A) of transformer (54) until a single peak is obtained on the meter connected to the AUXILIARY DIODE terminals. Check the adjustment of capacitor (49-2A) by turning the frequency dial to either side of the 455 kc frequency. Make sure that there are no secondary peaks and that the response curve is symmetrical.

(5) Disconnect the meter from the AUXILIARY DIODE terminals and switch on the modulation to the signal generator. Apply full voltage (1 volt) from the generator to the grid of the 12SA7 converter tube. Tune the frequency of the generator to exactly 470 kilocycles and adjust the trimmer on i-f transformer (44) (figure 9) to MINIMUM output. With full voltage still applied to the grid of the 12SA7, tune the generator to 485 kilocycles and adjust the trimmer of transformer (43) to MINIMUM output. After adjusting transformers (43) and (44) to minimum output, reset the generator to 455 kilocycles and check to see whether or not the output indicator shows a maximum peak at 455 kilocycles. If not, do the adjustments over again.

NOTE: If the signal generator available does not have an output of one volt or more, the receiver h-f oscillator may be used for the above adjustments. Turn the FREQ. BAND switch to band 1. Use a d-c milliammeter (preferably with a shunt so as to avoid overloading and damaging the meter if too great a signal voltage is applied) connected to the AUXILIARY DIODE terminals. Tune the receiver to 15 kilocycles and adjust the trimmer of transformer (44) to minimum output. Then tune the receiver to 30 kilocycles and adjust the trimmer of transformer (43) to minimum output.

b. Alignment of the beat frequency oscillator.—(1) Loosen the screws on the BEAT OSC. PITCH control knob and set the variable capacitor so that it is as nearly half open as can be determined with the eye. With the capacitor in this position, set the BEAT OSC. PITCH knob pointer so that it sticks straight up.

(2) Connect the signal generator and output meter as outlined in paragraph 33a(1). Turn on the signal generator and receiver (use a

modulated signal) and tune the generator to exactly 455 kilocycles. Turn the CRYSTAL SELECTIVITY control to position 2 and retune the signal generator at 455 kilocycles to maximum output.

(3) Use a headset plugged into the OUTPUT receptacle on the front panel, or connect a speaker to the OUTPUT terminals on the back of the chassis. Then adjust the screw on the top of the beat oscillator transformer (55) (figure 9) until the signal heard in the headset or speaker is at its lowest pitch.

c. Alignment of r-f stage.—(1) Connect the output leads from the signal generator to the 100 ohm balanced antenna input receptacle through a 100 ohm resistor. Set the **FREQ. BAND** switch on band 1. Make sure the antenna switch located on the back of the chassis (figure 2) is in the 100 ohm position, that is, with the switch arm down, and that the slot in the **ANT. TRIMMER** is in line with the black line on the chassis. The black half of the trimmer must be to the right and slightly down. Tune the signal generator to 28 kilocycles, set the receiver calibration to the same frequency and adjust the variable trimmer capacitors of the oscillator transformer (90), r-f transformer (26) and antenna transformer (7) (figure 9) for maximum output. When the above adjustments have been made, set the signal generator and receiver to 15 kilocycles. Adjust the padder (34) capacitance, located on the side of the chassis (when the receiver is in an upright position and the panel is towards you), to maximum output. Retune the receiver slightly and see if output increases. If it does, tune to maximum output and again readjust the padder (34), retune again and proceed with alternate padder adjustment and retuning until the output cannot be increased further by either retuning or padder adjustment. Retune to 28 kilocycles and, if necessary, readjust the oscillator trimmer to maximum.

(2) Use a similar procedure for aligning bands 2 and 3. Use 66 kilocycles for band 2 trimmers and 32 kilocycles for the (33-1) padder (figure 14). The band 2 oscillator, r-f, and antenna transformers are numbered (91), (27) and (8) respectively. Use 150 kilocycles for trimmers of band 3 and 70 kilocycles for the padder (33-2) (figure 14). The band 3 oscillator, r-f, and antenna transformers are numbered (92), (28) and (9) respectively.

34. DISASSEMBLY AND REASSEMBLY OF FRONT PANEL AND DIAL ASSEMBLY.

WARNING: HAVE A HEART WHEN YOU'RE TAKING THINGS APART. BE SURE EVERYTHING IS LOOSE BEFORE YOU TRY TO REMOVE A PART.

a. Front panel.—(1) Remove all knobs except the **BEAT OSC. PITCH**; loosen the screws holding them just enough to slip them off.

Before taking off the BEAT OSC. PITCH knob, completely close the variable capacitor just back of the knob; note especially where the pointer is because it has to be put back in this exact position. Unsolder the two wires connecting to the BEAT OSC. ON-OFF switch back of the panel. Unscrew the knurled nut on the POWER ON-OFF switch. Now remove the following screws: the one near the OUTPUT, the one between AUDIO GAIN and AUDIO TONE, the one near the middle of each handle, and the one in the top of each handle holding the handle to both front panel and side bracket. Lift the panel off, but TAKE IT EASY; you might have forgotten to loosen something. Leave the handles on the panel.

(2) When putting the front panel back on, you are apt to have some trouble replacing the nut and screw near the middle of the left handle. Wrap a small piece of wire or solder around the lockwasher and place the washer on the screw. Do the same with the nut. Use a pair of long-nose pliers to hold the nut when the screw is tightened. Be sure to replace the BEAT OSC. PITCH knob with the pointer exactly as it was when you took it off, with the capacitor all the way in. Make sure all the dial knob set screws are tight.

b. Dial and hub assembly.—(1) Turn the **FREQ. BAND** knob to position 2. Then remove the front panel (paragraph 34a(1)). Separate the bottom end of the metal bar, which is riveted to the dial mask, from the band switch arm by removing the nut, lockwasher, spring washer and screw. There is a hole in the front of the chassis so that the screw can be taken out. Take out the screw, lockwasher, and slotted washer which hold the dial mask on the drive shaft. Loosen the two set screws on the hub of the dial. Pull off the dial mask and dial.

(2) Take the set screws out of the hub of the old dial and put them in the new one. Put on the new dial and hub assembly. **DO NOT** tighten the set screws yet. Put the slotted washer, lockwasher, and screw on the dial shaft. Screw tight but be careful not to strip the threads of the screw. Now connect the metal bar of the dial mask to the arm on the band switch shaft with the special screw, spring washer, lockwasher, and nut. Do not screw the nut tight as adjustments still have to be made. Put the front panel back on (see paragraph 34a(2)).

(3) Adjustment of dial and dial mask.—(a) Turn the **TUNING** knob to the right as far as it will go. Push the dial and dial mask up tight against the washer and screw on the end of the shaft. With the fingers, turn the dial to the right until the last line on the low frequency end of the dial lines up with the "hair line" indicator. Screw the set screws tight. If time permits, check the tuning calibration.

(b) Line up the dial mask so that the slots in the mask line up properly for each band. Turn the receiver upside down and move it forward until the front panel sticks out over the edge of the bench about

two inches, so that you can move the dial mask with your fingers. Turn the dial mask until both ends of the slot for band 2 are equally distant from the "hair line" indicator. When satisfied that the dial mask is properly lined up, tighten the nut on the screw which holds the band switch arm to the metal bar on the dial mask; turn the **FREQ. BAND** knob to the other two positions to see if the other two slots also line up correctly. If one band does not, the adjustment on band 2 must be done over again.

35. REPLACEMENT OF CRYSTAL FILTER, SWITCH AND SOCKET.—a. Crystal filter switch.—(1) When removing the crystal filter switch, take off the crystal filter cover by unscrewing the four screws on top of the filter can. Remove the **CRYSTAL SELECTIVITY** knob from the front panel. Unscrew the nut holding the filter switch to the filter can. Use a crescent wrench or a straight wrench with a 1/2-inch jaw width. If you don't have such a wrench, the front panel must be removed so that the nut can be loosened with pliers (see paragraph 34a(1) for removal of front panel). Take out the screws holding terminal board (131) to the chassis and unsolder enough of the leads so that it can be moved out of the way. Unsolder the green, yellow, and bare leads which pass through the grommets on the chassis from the filter switch to the i-f transformer and ground lug. Then, pull the switch out of the filter can.

(2) When putting in a new switch, make sure all leads and resistors have good connections to their proper positions on the switch (figure 15). Then push the leads through the rubber grommets (by pushing the leads straight through the grommets there will be less chance of knocking them out). Put the switch shaft through the hole in the filter can; put the lockwasher and nut on the shaft, then push the shaft through the hole in the front panel, if the front panel has not been removed. Make sure the guide pin on the switch is in the hole provided for it and screw the nut on the shaft tight to the filter can. Solder the yellow lead to No. 5 terminal on transformer (51) and the green lead to No. 1 terminal of transformer (54) and solder the bare lead to the ground lug. Screw the terminal board back to the chassis (be sure there is a lockwasher with each screw) and reconnect the leads to the terminal board. Make sure the crystal is in the crystal socket holder, then screw the crystal cover to the can (don't forget lockwashers).

b. Crystal filter socket.—(1) To remove the crystal socket, take out the screws holding terminal board (131) to the chassis and unsolder enough of the leads so that you can move it out of the way. Now you can get at the two lugs of the crystal socket. Unsolder the leads from the lugs. Remove the shield cover by unscrewing the four screws on top of the cover. Pull out the crystal, remove the screw in the center of the socket and pull out the socket.

(2) Set in the new crystal socket and screw it to the chassis. Make sure the screw is tight. Connect and solder the leads to the lugs on the socket. Screw the terminal board back to the chassis (don't forget lockwashers). Resolder the wires to the terminal board. Replace the shield cover, put on the lockwashers and screws.

36. REPLACEMENT OF FIXED CAPACITORS.—a. Capacitor 16-1A, B & C.—(1) To remove capacitor (16-1), unsolder and take off all leads which are connected to the capacitors and ground lugs mounted on the chassis shield (116) (figure 14). Remove the screws and nuts which hold the chassis shield to the chassis. Take off the capacitor by removing the screws which hold it to the shield.

(2) Put on the new capacitor. Make sure you use a lockwasher with each screw. Replace the chassis shield on the chassis. Clean wire leads and resolder them to the proper lugs of the capacitors.

b. Capacitor 16-2A, B, & C.—Follow the exact procedure of the preceding paragraph to remove and replace this capacitor.

c. Capacitor 16-3A, B, & C.—(1) To remove capacitor 16-3, take out the crystal filter switch (see paragraph 35a(1)). Remove the crystal filter can by unscrewing the four screws on the top of chassis. Remove the wires from the lugs on the capacitor; take out the screws and nuts which hold the capacitor and "U" bracket to the chassis. Lift the capacitor and mounting bracket out. Remove the bracket from the capacitor.

(2) Put the bracket on the new capacitor, put on the nuts and screws (use a lockwasher with each screw). Put the capacitor in the hole and screw the capacitor bracket to the chassis. Clean the wire leads and make a good mechanical and well-soldered connection. Put the crystal filter can on the chassis (be sure to use a lockwasher with each screw). Replace crystal filter switch (see paragraph 35a(2)). Put on the crystal shield cover.

d. Capacitor 47.—(1) Remove the top screw and nut and loosen the bottom screw and nut. Unsolder the two wire leads from the lugs of the capacitor and turn it over so that you can reach the bottom screw. Take out the bottom screw and nut and lift out the capacitor.

(2) Put the capacitor on the shield, inserting the bottom screw first. Put on the lockwasher and nut and tilt the condenser up so that the top screw, lockwasher, and nut also may be put on. Tighten the screws. Clean the wire leads and resolder them to the proper lugs.

37. REPLACEMENT OF BAND SWITCH AND LIMITER SWITCH.—a. Band switch.—Replacing the band switch is the most difficult of all. To avoid errors refer to the practical wiring diagram, figure 15.

(1) Unsolder from the band switch the green and white leads and the red lead which go through the chassis, and the blue lead which goes to the r-f amplifier tube socket (V_1). Unsolder all the wires and capacitors which are connected to the band switch from the transformers, padder capacitors, 100 ohm balanced input plug, terminal boards (159) and (129), and whip antenna trimmer capacitor. Now take off the front panel (see paragraph 34a(1)). Then unscrew the two flathead screws which hold the hub for the band switch shaft to the chassis. Take out the screw, nut, lockwasher, and springwasher which connect the arm on the band switch shaft to the metal bar which passes through the chassis to the dial mask. Take out the two screws which hold the band switch to the chassis and lift the switch out.

(2) Take one wire at a time from the old switch and put it in exactly the same place on the new one. Do this for all the wires except the maroon and blue wires which are twisted together. These will have to be taken off and put back on without untwisting. Don't forget to put the spaghetti covered wire lead through the two wafers at the back of the switch. Put the hub on the shaft and put the switch in the chassis. Put on the screws and nuts that hold the switch to the chassis and tighten them. Then screw the two flathead screws into the hub. Now solder the wires from the switch to the transformers, padder capacitors, 100 ohm balanced input plug, terminal board (159), whip antenna, trimmer capacitors, and ground lugs (figure 15). Connect the two green and white wires, the red wire which comes through the chassis, the blue wire from the tube socket and the green wire from the terminal board to the switch. Now put the front panel back on and the job is finished.

b. Limiter switch.—(1) First, remove the limiter shield (114) (figure 14) that surrounds this section. Two screws fasten it to the side and one to the top of the chassis. Remove the screws and lift the shield out. Unsolder from the tube sockets the green and the brown leads which connect the switch to the tube sockets. Unsolder the brown lead from the ground lug and the bare lead from the No. 6 terminal lug on the third i-f transformer. Loosen the screws on the LIMITER knob and pull off the knob. Unscrew the large hex. nut that holds the switch to the front panel and pull the switch shaft out of the hole. Then unsolder the blue lead which connects the switch to the transformer and lift the switch out. Take the resistors and wires off of the old switch and remove all the excess solder from the ends.

(2) Connect the resistors and wires to the proper lugs on the new switch. Be sure to do it correctly. (See figure 15.) Next, solder the blue lead to the No. 5 transformer terminal lug. Put the switch back on the chassis. Make sure the guide pin is in the hole which is beside the switch shaft hole. Screw on the hex. nut and don't forget the lockwasher. Then resolder the other leads to their proper lugs. Now put on the LIMITER knob and the shield. Be sure to put the LIMITER

knob on correctly so that the pointer will turn to each of the positions marked on the front panel. Don't forget the lockwashers when you screw the shield back to the chassis.

38. REPLACEMENT OF TRANSFORMERS.—a. Transformers.

—(1) All transformers, except the beat oscillator and third i-f (see paragraphs 38b & c) are removed as follows: Unsolder and pull free all wires from the lugs of the transformer being removed. Remove the nuts from the screws that hold it to the chassis and take it out.

(2) When putting in the new transformer, be sure that terminal lug No. 1 of the r-f transformers is toward the band switch. On the h-oscillator, first and second i-f transformers, terminal lug No. 1 must be placed toward the front of the chassis. When the new transformer is set in the correct position, put the lockwashers and nuts back on the screws. Remove all excess solder from the wires which you took off, then put them back on the proper lugs and solder them. Be sure all connections are good and solid.

CAUTION: WHEN SOLDERING, DON'T HOLD THE IRON ON THE LUGS TOO LONG AND DON'T USE TOO MUCH SOLDER OR IT MAY RUN DOWN THROUGH THE HOLE IN THE CENTER OF THE LUG AND SHORT THE COIL.

b. Beat oscillator transformer.—(1) First, you'll have to take off the shield (113) (figure 14) that surrounds this section on the bottom of the chassis. Two screws fasten it to the side and three to the top of the chassis. Remove these and lift the shield out. Unsolder the wires from the lugs of the transformer, remove the nuts from the two screws holding it to the chassis and take it out.

(2) Set in the new transformer and be sure that terminal lug No. 1 is toward the band switch shaft. Put the lockwashers and nuts back on the screws that hold the transformer to the chassis. Clean the wires, replace them on the proper lugs, and solder them. See CAUTION in paragraph 38a(2). Replace the shield.

c. 3rd i-f transformer.—(1) Remove the limiter shield and switch as described in paragraph 37b(1), but disconnect only the bare and blue wires, which connect the switch to the transformer from the No. 6 and No. 5 terminal lugs respectively. Now you can bend the switch back out of the way to get to the transformer. Remove the nuts from the screws which hold the transformer to the chassis. Unsolder the wires on the lugs and take the transformer out.

(2) Set in the new transformer making sure that No. 1 terminal lug is toward the band switch. Put the lockwashers and hex. nuts back on the screws that hold the transformer to the chassis. Clean and solder

the wires back in their correct places on the terminal lugs. Then proceed, as described in paragraph 37b(2), to put back the limiter switch and knob. Check the knob after you fasten it on to be sure the pointer is in the proper position so that it can be turned to the four positions stamped on the front panel. Put the limiter shield back on.

39. REPLACEMENT OF GANG CAPACITOR.—a. Remove the gang capacitor shield by unscrewing the four thumb screws and lifting the shield off the capacitor. (If the thumb screws are too tight, use a screwdriver, dime, or penny.) Unsolder the three bare leads from the ground lugs on top of the chassis. Unsolder from the band switch the two green and white leads and the red lead which pass through grommets in the chassis to the gang capacitor. Unsolder the green leads from No. 4 terminal lug of the 12SK7 r-f amplifier tube (V_1) and from No. 8 terminal lug of the 12SA7 converter tube (V_2); these leads also pass through grommets in the chassis to the capacitor. Unscrew the four screws and nuts holding the capacitor to the chassis and pull the capacitor and wires free from the chassis. When pulling the capacitor off, hold on to the porcelain piece of the slide coupling which connects the capacitor shaft to the drive shaft so that it doesn't come off. If it does, push it back on the drive shaft section.

b. Remove the mounting brackets from the old capacitor and put them on the new one. Take off the portion of the slide coupling attached to the shaft of the old capacitor and clamp it on to the rest of the slide coupling which is on the drive shaft. Do not screw the piece tight as it will be necessary to reset the capacitor. Remove the wires from the old capacitor, clean them, and solder them on the new one. Also clean the ground lugs on the chassis before putting the wires back on. Put the wires from the capacitor through the rubber grommets in the chassis; be sure the wires are in the proper holes. (Be careful not to knock the grommets out when pushing the wires through the holes.) Put the capacitor shaft into the slide coupling and make sure the two sets of clips which fasten to the porcelain piece of the slide coupling are joined securely. Screw the capacitor brackets to the chassis. The screw heads must be on the bottom and the nuts on top of the chassis. Don't forget the lock-washers. Be sure the two cable clamps are put back when you screw the capacitor to the chassis. Solder the two green and white leads and the red lead to the band switch and the two green leads to the tube sockets.

c. Now reset the capacitor. Keep turning the TUNING knob to the right (clockwise), as you face the chassis, until it stops. The low frequency end of the dial (back of 15 kilocycles) should now line up with the "hair line" pointer. Turn the gang capacitor shaft all the way to the right with the fingers and then tighten the screws on the slide coupling connector. Put on the capacitor shield and screw on the four thumb screws. A dime or penny may be used to tighten them.

NOTE: The r-f section of the receiver will have to be re-aligned.

40. REPLACING TUBE SOCKETS.—The only time it will be necessary to replace a tube socket is when the bakelite is badly cracked or broken. If a single lug is broken, take the tube out of the socket and push the broken lug out through the top of socket with a small thin screwdriver or a piece of flat metal. Remove a good **unused** lug from one of the other sockets to replace the broken one.

a. When removing a tube socket, remove all the wires from the lugs and, with a screwdriver, pry off the spring washer which holds the socket firmly to the chassis. When the spring washer is removed, press the tube socket out of the chassis. Note the position of the guide pin, as it is necessary to place the guide pin of the new socket in exactly the same position as the one removed.

b. Put in the new socket so that the guide pin is in **exactly** the same location as the one removed. If a check is needed, see figure 15. Put the spring washer around the socket and press it down with a screwdriver so that it slips into the groove of the socket and holds the socket firmly in the chassis.

41. SERVICING POWER SUPPLY UNIT RA-61-A.—The power supply unit will always have to be taken out of the case for servicing. To do this, remove the two screws from each side of the case and also the four screws on both the top and bottom. Turn the unit so that it stands on the handles and lift the case off. Always take out the tubes while servicing so they won't be broken.

a. **Filter capacitors.**—(1) To remove the filter capacitors, first loosen the **BACK PLATE** (see figure 10) from the three posts on each side of the power unit to which the plate is mounted. Take out the six screws and it will be free. Take the wires off of the capacitor by unscrewing the nuts and lifting the wires from it. Remove the four screws from the bracket that holds the three capacitors in place. Lift the bracket off. **BE CAREFUL** not to break any fuses. Now pull the capacitor out.

(2) Put the new capacitor in its proper place; set the capacitors in the retaining bracket and screw the bracket on to the **BACK PLATE**. Use the lockwashers. **BE SURE** to put the cardboard spacers between the capacitors and on the ends. Put the wires on the screws of the capacitor, put on the nuts and tighten them. Screw the **BACK PLATE** on to the posts (use lockwashers). Put the case back on.

b. **Choke coils.**—(1) Take out the six screws and spacers that hold the **FRONT PANEL** (figure 10) to the posts. Take out the top screw and nut which hold the choke to the panel. Lay a small flat board or other strong material (bottom chassis plate if available) across the back part of the power unit. Now turn the front section over on top of the board. Take out the other two screws which hold the choke to the **FRONT PANEL**. Unsolder the wires and take the choke out.

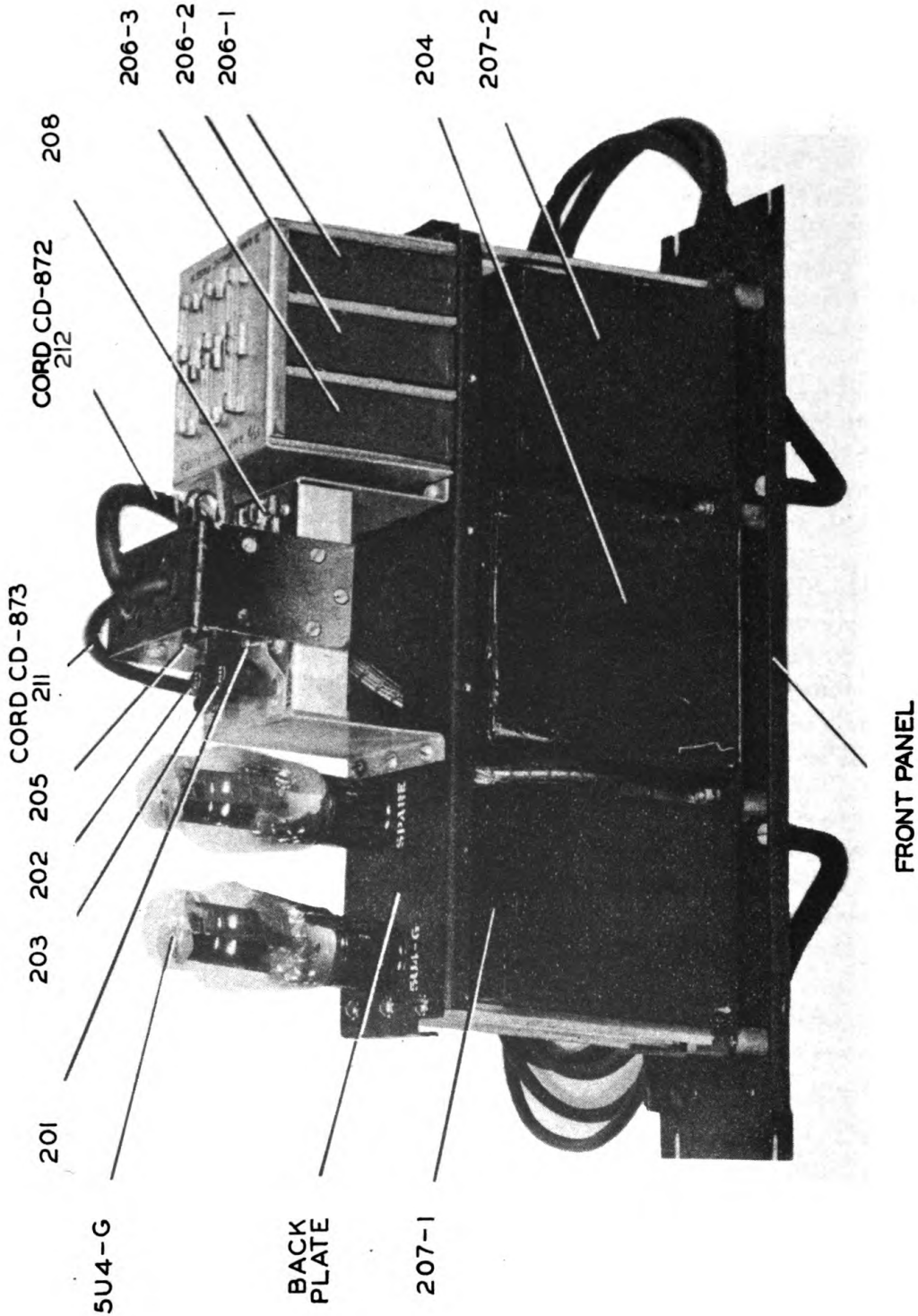

Figure 10. Power Supply Unit RA-61-A, interior view

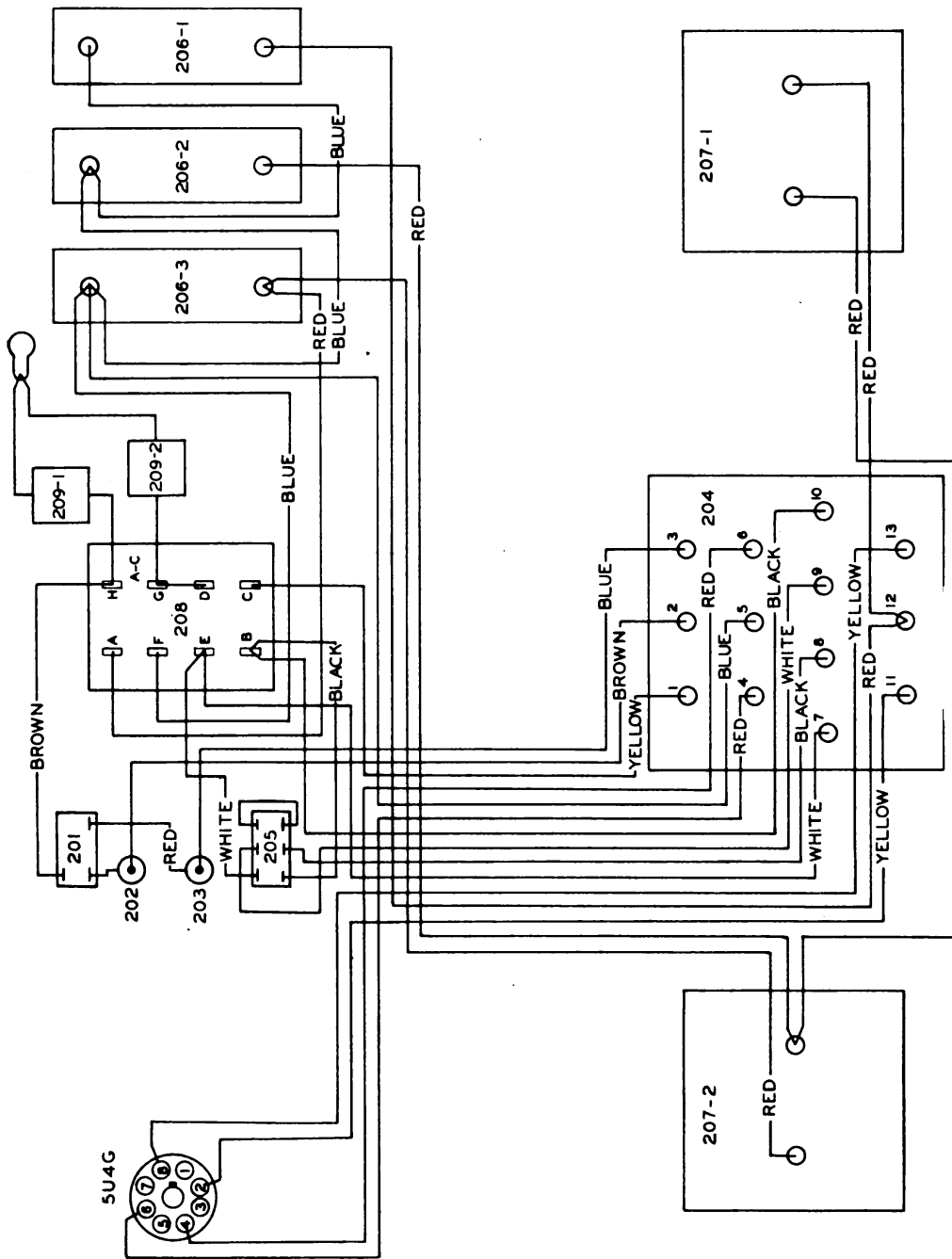

Figure 11. Power Supply Unit RA-61-A, practical wiring diagram

(2) Solder the wires to the new choke. Set the choke in position and put in the spacers and screws. Put the lockwashers on with a pair of long nose pliers and hold the nuts with the pliers while you tighten the screw with a screwdriver. Turn the front section back and place it in position. Put in the spacers and screws and fasten the FRONT PANEL to the rear section of the unit. Put in the tubes, put the case on and the job is done.

c. Transformer.—The procedure for the removal and re-assembly of the transformer is identical with that for the choke coils except that all six screws, three on either side, have to be removed. To avoid mistakes, take the wires one at a time off of the old transformer and put them on the new one. See figure 11.

42. PERFORMANCE CHARACTERISTICS.—a. Sensitivity and signal to noise ratio.—Signal input modulated 30% at 400 cycles. Ten milliwatts output. One hundred ohm dummy antenna for 100 ohm antenna input condition, 100 micromicrofarad dummy antenna for WHIP antenna input condition.

On all three bands, using either the 100 ohm or the whip antenna connection, the signal strength is at least six decibels greater than the noise strength.

The sensitivity on all three bands with the 100 ohm antenna is five microvolts; with the whip antenna it is 150 microvolts.

b. Selectivity.—Measured at 100 kilocycles.

Ratio of Input off Resonance to Input at Resonance	Band Width, kilocycles
1 to 10	8
1 to 100	14.5
1 to 1000	20

c. Overall fidelity.—Measured at 100 kilocycles. Variation in output over frequency range 250 cycles to 2500 cycles, 14 db.

d. Distortion.—Overall distortion, 2 watts output, 10%.

e. Image ratio.—The strength of the received signal is at least 5,000 times greater than that of the image at any frequency.

f. Intermediate frequency rejection ratio.—The output volume of the incoming signal is at least 5,000 times greater than that of the intermediate frequency at any frequency.

g. Automatic volume control.—Audio output will remain almost constant with an input signal variation of 100 to 100,000 microvolts.

h. Beat frequency oscillator.—Pitch variation 0 to 5000 cycles. Output 500 milliwatts or greater for any signal input above 5 microvolts.

43. MOISTURE PROOFING.—While this set is designed to withstand moisture, conditions, accidental or otherwise, may make it necessary to dry or moisture proof it. If so, proceed as follows:

a. Preparations for drying.—(1) Check the equipment to see that it is operating properly. Make any repairs necessary to put the set in normal condition. Then thoroughly clean the set of all dirt, dust, grease, rust, and corrosion spots.

(2) Remove the set from its case and remove the shields from the transformers and coils. Take out the tubes and the crystal filter assembly. Apply masking tape as a protective covering to all moving parts, switch contacts, variable air capacitors, bearings, pin connections (such as tube sockets), the band switching mechanism and detent, and to all other points where a coating of varnish will prevent electrical continuity. Where possible, lift the wiring from the chassis, leaving an air space between the wire and the metal chassis. (This does not apply to wiring directly connected to ground points.)

b. Drying.—(1) Place the equipment in the heating oven or apparatus and leave it there for approximately two hours. Hold the temperature inside the oven to about 160° F. Place the thermometer in a convenient position so that it may be read easily.

CAUTION: DO NOT EXCEED 160° F.

(2) Watch for any indication of melted wax. If this occurs, lower the temperature accordingly and add one hour to the total baking time for each 10° F. drop. Where it is possible, rotate the equipment inside the oven every half hour to insure complete baking.

c. Spraying.—(1) Mix the varnish and thinner such as that provided in Moisture and Fungus Proofing Kit MK10/GSM, to spraying viscosity; approximately one and one-half to two parts of varnish to one part thinner. (Example: two pints of varnish plus one pint of thinner equals three pints of spraying varnish.)

(2) Fill the spray gun provided in the moisture proofing kit with this mixture.

(3) At the end of the drying period, spray the mixture over all unmasked circuit elements. Do this inside a closed but properly venti-

lated van, building or tent in order to prevent reabsorption of moisture and dust. Paint with a brush all parts that cannot be reached by spraying.

CAUTION: DO NOT USE SPRAY NEAR OPEN FLAME.

(4) When spraying, be sure to have a fine spray that creates a swirling, penetrating mist.

(5) After completing the first coat, return the set to the oven for ten minutes and then repeat the spraying. Do this again for the third coat. Turn off the oven and then leave the set in it until it cools. Do not handle the set until the varnish has dried. *If the varnish is sticky it is not dry.*

d. Painting.—(1) After the set has dried and it can be safely handled, remove the masking tape. Paint all parts that require varnish, such as parts that were covered by masking tape due to their closeness to moving parts.

(2) Remove the can shields from the i-f and r-f transformers, and paint with varnish all the bakelite separators.

(3) Remove oscillator coils (Nos. 7, 23, 26) and dip the bottom part of the coil (bakelite) in varnish. Plug all holes in the iron shielding. Replace the coils and where the iron shielding mates with the chassis, paint the seam to seal.

(4) Paint the bakelite terminal strips on the back chassis.

(5) On Power Supply Unit RA-61-A, remove and discard the cardboard spacers between the filter capacitor, and replace them with bakelite or other material that has been varnish treated. Paint the bakelite terminal strip and all wiring that has not been sprayed. Remove the cambric tape from the cable form between the transformers, the tube socket, and the capacitors, and varnish well. If necessary, unlace the cable so that all wiring will be treated.

e. Operational check.—(1) Replace all parts that have been taken off, such as transformer shields, and put back the tubes, and crystal filter assembly. Re-lace any cables that have been undone and rewind the cable form with cambric tape. (The lacing and cambric tape should also be varnished.)

(2) Check all exposed contacts for electrical continuity. If the varnish has caused poor contact, clean with thinner or varnish remover. Be sure to wipe clean.

(3) Check all switches for proper operation.

(4) Check the receiver for sensitivity and alignment, and for proper operation of the crystal filter.

SECTION V
SUPPLEMENTARY DATA

44. TABULAR LIST OF REPLACEABLE PARTS FOR RADIO SET SCR-614-A

Ref. No.	Quan. in Equip.	Sig. Corps Stock No.	Name and Description of Part	Function	Mfr. Code and Type No.	Majestic Dwg. No.
#1-1	7		RADIO RECEIVER BC-969-A Capacitor, air trimmer, 3.6 MMF. Min., 26 MMF. Max. cap., 4 stator, 5 rotor plates, .020" air gap., ceramic mtg. base, $1\frac{7}{32}$ " x $1\frac{15}{16}$ " x $1\frac{1}{4}$ "	Ant. series coupling trimmer	AS Type 25-L	8 E 3
1-2		Capacitor, same as 1-1, not replaceable, part of trans. ass'y (7)	Trimmer, Ant. trans. band 1
1-3		Capacitor, same as 1-1, not replaceable, part of trans. ass'y (8)	Trimmer, Ant. trans. band 2
1-4		Capacitor, same as 1-1, not replaceable, part of trans. ass'y (9)	Trimmer, Ant. trans. band 3
1-5		Capacitor, same as 1-1, not replaceable, part of trans. ass'y (26)	Trimmer, R-F sec. band 1
1-6		Capacitor, same as 1-1, not replaceable, part of trans. ass'y (27)	Trimmer, R-F sec. band 2
1-7		Capacitor, same as 1-1, not replaceable, part of trans. ass'y (28)	Trimmer, R-F sec. band 3

#	3	Ant. switch	CH	11 E 4
# 2-1	3	Switch, S.P.D.T. toggle, single section, 1 1/2 amps. at 250 V., 3 amps. at 125 V., 1" x 1/2" x 1 7/8", bushing 1 1/8" -32	#8282	11 E 4
# 2-2	Switch, same as 2-1
# 2-3	Switch, same as 2-1
# 3	1	Receptacle, SO-329, 1 pole female	AP 83-IR	15 E 1 †SC-D-5850
# 4	1	Resistor, fixed, carbon, insulated, 680,000 ohms, ± 10%, 1/2 watt, 7/16" x 7/32", axial leads	AB EB 6841	9 E 22
# 5	1	Receptacle, SO-264, 2 pole female	AP 83-22R	15 E 3 †SC-D-5941
# 6-1 to 6-8	1	Switch, rotary selector, 3 positions, 8 poles, shorting type contacts, ceramic insulation, 1 3/4" dia. x 7 1/2" long body, shaft 1/4" dia. x 3 3/4" long. Special	C 36BHXC-6766X	11 E 3
# 7	1	Transformer ass'y, R-F, 15-30 KC; includes trans. (93), one trimmer cap. (1-2), one temp. comp. (10-1); enclosed in zinc shield can with phenolic base, 2 1/8" dia. x 4 1/2", six terminals	M	3 E 15

Available in Depot Stock.

* Supplied with equipment as running spares.

† See Drawing.

TABULAR LIST OF REPLACEABLE PARTS FOR RADIO SET SCR-614-A

Ref. No.	Quan. in Equip.	Sig. Corps Stock No.	Name and Description of Part	Function	Mfr. Code and Type No.	Majestic Dwg. No.
# 8	1		Transformer ass'y, R-F, 30-67.5 KC; includes trans. (94), one trimmer cap. (1-3), one temp. comp. (11-1); enclosed in zinc shield can 1 3/4" sq. x 4 1/2" high	Ant. input, band 2	M	3 E 10
# 9	1		Transformer ass'y, R-F, 67.5-150 KC; includes trans. (95), one trimmer cap. (1-4), one temp. comp. (11-2), shield can same as (8)	Ant. input, band 3	M	3 E 11
10-1	3		Capacitor, fixed, 4 mmf., ± .5 mmf., 500 volts, ceramic, —.00075 T.C., 7/16" x 1/4" dia.; not replaceable, part of trans. ass'y (7)	Temp. comp. ant. cir. band 1	C 807-078	6 E 15
10-2		Capacitor, same as 10-1; not replaceable, part of trans. ass'y (27)	Temp. comp. r-f section band 2
10-3		Capacitor, same as 10-1; not replaceable, part of trans. ass'y (28)	Temp. comp. r-f section band 3
11-1	4		Capacitor, fixed, 20 mmf., ± 10%, 500 volts, ceramic, —.00015 T.C., 7/16" x 1/4" dia.; not replaceable, part of trans. ass'y (8)	Temp. comp. ant. cir. band 2	C 812-158	6 E 20
11-2		Capacitor, same as 11-1; not replaceable, part of trans. ass'y (9)	Temp. comp. ant. cir. band 3

11-3	Capacitor, same as 11-1; not replaceable, part of trans. ass'y (26)	Temp. comp. r-f section band 1
#11-4	Capacitor, same as 11-1	Crystal phasing series cap.
#12-1	13	Capacitor, fixed, .01 mf., $\pm 20\%$, 600 volts, paper, oil-filled, tinned brass case, 1" x $1\frac{3}{16}$ ", #20 wire leads $1\frac{1}{2}$ " long, 1 terminal gnd.	A.V.C. by-pass	F #7237 6 E 5
#12-2	Capacitor, same as 12-1	Plate by-pass r-f ampl.
#12-3	Capacitor, same as 12-1	B plus noise filter
#12-4	Capacitor, same as 12-1	Plate by-pass h-f osc.
#12-5	Capacitor, same as 12-1	Plate by-pass converter
#12-6	Capacitor, same as 12-1	Plate by-pass 1st i-f ampl.
#12-7	Capacitor, same as 12-1	Plate by-pass, beat osc.
#12-8	Capacitor, same as 12-1	Plate by-pass, 2nd i-f ampl.
#12-9	Capacitor, same as 12-1	A.V.C. by-pass, diode cathode
#12-10	Capacitor, same as 12-1	By-pass, heater circuit

TABULAR LIST OF REPLACEABLE PARTS FOR RADIO SET SCR-614-A

Ref. No.	Quan. in Equip.	Sig. Corps Stock No.	Name and Description of Part	Function	Mfr. Code and Type No.	Majestic Dwg. No.
# 8	1		Transformer ass'y, R-F, 30-67.5 KC; includes trans. (94), one trimmer cap. (1-3), one temp. comp. (11-1); enclosed in zinc shield can 1 3/4" sq. x 4 1/2" high	Ant. input, band 2	M	3 E 10
# 9	1		Transformer ass'y, R-F, 67.5-150 KC; includes trans. (95), one trimmer cap. (1-4), one temp. comp. (11-2), shield can same as (8)	Ant. input, band 3	M	3 E 11
10-1	3		Capacitor, fixed, 4 mmf., ± .5 mmf., 500 volts, ceramic, — .00075 T.C., 3/16" x 1/4" dia.; not replaceable, part of trans. ass'y (7)	Temp. comp. ant. cir. band 1	C 807-078	6 E 15
10-2		Capacitor, same as 10-1; not replaceable, part of trans. ass'y (27)	Temp. comp. r-f section band 2
10-3		Capacitor, same as 10-1; not replaceable, part of trans. ass'y (28)	Temp. comp. r-f section band 3
11-1	4		Capacitor, fixed, 20 mmf., ± 10%, 500 volts, ceramic, — .00015 T.C., 3/16" x 1/4" dia.; not replaceable, part of trans. ass'y (8)	Temp. comp. ant. cir. band 2	C 812-158	6 E 20
11-2		Capacitor, same as 11-1; not replaceable, part of trans. ass'y (9)	Temp. comp. ant. cir. band 3

11-3	Capacitor, same as 11-1; not replaceable, part of trans.assy (26)	Temp. comp. r-f section band 1
#11-4	Capacitor, same as 11-1	Crystal phasing series cap.
#12-1	13	Capacitor, fixed, .01 mf., $\pm 20\%$, 600 volts, paper, oil-filled, tinned brass case, 1" x $1\frac{3}{16}$ ", #20 wire leads $1\frac{1}{2}$ " long, 1 terminal gnd.	A.V.C. by-pass	6 E 5
#12-2	Capacitor, same as 12-1	Plate by-pass r-f ampl.
#12-3	Capacitor, same as 12-1	B plus noise filter
#12-4	Capacitor, same as 12-1	Plate by-pass h-f osc.
#12-5	Capacitor, same as 12-1	Plate by-pass converter
#12-6	Capacitor, same as 12-1	Plate by-pass 1st i-f ampl.
#12-7	Capacitor, same as 12-1	Plate by-pass, beat osc.
#12-8	Capacitor, same as 12-1	Plate by-pass, 2nd i-f ampl.
#12-9	Capacitor, same as 12-1	A.V.C. by-pass, diode cathode
#12-10	Capacitor, same as 12-1	By-pass, heater circuit

TABULAR LIST OF REPLACEABLE PARTS FOR RADIO SET SCR-614-A

Ref. No.	Quan. in Equip.	Sig. Corps Stock No.	Name and Description of Part	Function	Mfr. Code and Type No.	Majestic Dwg. No.
#12-11		Capacitor, same as 12-1	By-pass, power circuit
#12-12		Capacitor, same as 12-1	By-pass, power circuit
#12-13		Capacitor, same as 12-1	By-pass, 2nd i-f ampl. cathode
#13-1	4		Resistor, fixed, carbon, insulated, 270,000 ohms, $\pm 10\%$, $\frac{1}{2}$ watt, $\frac{7}{16}$ " x $\frac{7}{32}$ ", axial leads	A.V.C. isolation	AB EB 2741	9 E 2
#13-2		Resistor, same as 13-1	Plate load, 1st a-f ampl.
#13-3		Resistor, same as 13-1	Selectivity broad-ening crystal cir.
#13-4		Resistor, same as 13-1	Diode load, det.
#14-1	6		Resistor, fixed, carbon, insulated, 470,000 ohms, $\pm 10\%$, $\frac{1}{2}$ watt, $\frac{7}{16}$ " x $\frac{7}{32}$ ", axial leads	A.V.C. diode load	SC Type MS $\frac{1}{2}$	9 E 4
#14-2		Resistor, same as 14-1	A.V.C. isolation
#14-3		Resistor, same as 14-1	Noise limiter bias

#14-3

#14-4	Resistor, same as 14-1	Grid resistor, out-put tube	
#14-5	Resistor, same as 14-1	Loading resistor, ant. impedance	
#14-6	Resistor, same as 14-1	R-F filter, 1st a-f ampl.	
#15A, B, C	Capacitor, 3-gang, 14 MMF. Min., 389 MMF. Max. cap., 3 sections, 12 stator, 13 rotor plates per sect., .0235" air gap, ceramic mtg. plates, 2 3/4" x 3 3/16" x 6 3/8"	Signal selector	7 E 1
#16-1A, B, C	Capacitor, fixed, 3 x .1 mf., +14% -6%, 400 volts, paper, oil-filled, sealed metal housing, 3 terminal lugs, 1 3/4" x 1" x 1" Type CA-276	1A-Cathode by-pass, r-f ampl.	6 E 2 †SC-D-512
#16-2A, B, C	Capacitor, same as 16-1A, B C	1B-Screen by-pass r-f ampl. 1C-Decoupling cap. 2A-B + by-pass converter screen 2B-Screen by-pass, converter 2C-Cathode by-pass, converter	

TABULAR LIST OF REPLACEABLE PARTS FOR RADIO SET SCR-614-A

Ref. No.	Quan. in Equip.	Sig. Corps Stock No.	Name and Description of Part	Function	Mfr. Code and Type No.	Majestic Dwg. No.
#16-3A, B, C	1		Capacitor, same as 16-1A, B, C	3A-Grid by-pass, tuning ind. 3B-Screen by-pass, 2nd i-f ampl. 3C-Time constant cap., noise limiter		
17		This ref. no. not used			
#18-1	8		Resistor, fixed, carbon, insulated, 56,000 ohms, $\pm 10\%$, $\frac{1}{2}$ watt, $\frac{7}{16}$ " x $\frac{7}{32}$ ", axial leads	Screen resistor, r-f ampl.	AB Type EB 5631	9 E 1
#18-2		Resistor, same as 18-1	Screen volt. divider, r-f ampl.		
#18-3		Resistor, same as 18-1	Screen resistor, converter		
#18-4		Resistor, same as 18-1	Screen resistor, converter		
#18-5		Resistor, same as 18-1	Plate isolation, h-f osc.		
#18-6		Resistor, same as 18-1	Screen resistor, 1st i-f ampl.		

#18-7	Resistor, same as 18-1	Screen resistor, 2nd i-f ampl.
#18-8	Resistor, same as 18-1	Grid resistor, beat osc.
#19-1	4	Capacitor, fixed, .001 mf., ± 10%, 500 volts, mica, molded bakelite casing, 3/4" sq., A.S.A. Spec. 75.3 CM 30 B 102M, axial leads	Grid-plate shield, r-f ampl.	A Type 1467	6 E 19
#19-2	Capacitor, same as 19-1	Grid-plate shield, converter
#19-3	Capacitor, same as 19-1	Screen grid-plate shield, 1st i-f ampl.
#19-4	Capacitor, same as 19-1	Grid-plate shield. 2nd i-f ampl.
#20	1	Capacitor, fixed, 400 mmf., ± 5%, 500 volts, mica, 3/4" sq., tinned brass termi- nal leads	Tuning cap., r-f pri.	SM Type MWS	6 E 17
#21-1	6	Resistor, fixed, carbon, insulated, 2200 ohms, ± 10%, 1/2 watt, 7/16" x 7/32", axial leads	Plate isolation, r-f ampl.	AB EB-2221	9 E 7
#21-2	Resistor, same as 21-1	Plate isolation, converter
#21-3	Resistor, same as 21-1	Plate isolation, 1st i-f ampl.

TABULAR LIST OF REPLACEABLE PARTS FOR RADIO SET SCR-614-A

Ref. No.	Quan. in Equip.	Sig. Corps Stock No.	Name and Description of Part	Function	Mfr. Code and Type No.	Majestic Dwg. No.
#21-4		Resistor, same as 21-1	Plate isolation, 2nd i-f ampl.
#21-5		Resistor, same as 21-1	A.V.C. delay
#21-6		Resistor, same as 21-1	Cathode bias resistor, 1st i-f ampl.
#22-1	4		Capacitor, fixed, 200 mmf., ± 10%, 500 volts, ceramic, — .00075 T.C., 7/8" x 3/8" dia., axial leads	D-C isolation cap., ant. cir.	C 810-024	6 E 9
#22-2		Capacitor, same as 22-1	Coupling cap., h-f osc. to converter
#22-3		Capacitor, same as 22-1	Filter, aux. diode
#22-4		Capacitor, same as 22-1	Filter, aux. diode
#23	1		Coil, inductance, R-F, .497 millihenrys, 10 mmf. dist. cap., duolateral windings on powdered iron core, two pot cores, encased in powdered iron shell, mounted on Majestic coil framework with phenolic base, six terminals, zinc shield can 2 1/8" dia. x 4 1/2" high	Plate load, r-f ampl. band 1	M	3 E 16

#24	I	Coil, inductance, R-F, 112.8 millihenrys, 6.5 mmf. dist. cap., duo-lateral windings on powdered iron core, two pot covers, encased in powdered iron shell, mounted on Majestic coil framework with phenolic base, six terminals, zinc shield can 1 3/4" sq. x 4 1/2" high	Plate load, r-f ampl. band 2	M	3 E 6
#25	I	Coil, inductance, R-F, 23.6 millihenrys, 6.5 mmf. dist. cap., duolateral windings on powdered iron core, two pot cores, encased in powdered iron shell, mounted on Majestic coil framework with phenolic base, six terminals, zinc shield can 2 1/8" dia. x 4 1/2" high	Plate load, r-f ampl. band 3	M	3 E 8
#26	I	Transformer ass'y, R-F, 15-30 KC; includes trans. (99), one air trimmer (1-5), one temp. comp. (11-3), enclosed in zinc shield can 2 1/8" dia. x 4 1/2" high, phenolic base with six terminals	R-F selectivity band 1	M	3 E 17
#27	I	Transformer ass'y, R-F, 30-67.5 KC; includes trans. (100), one air trimmer (1-6), one temp. comp. (10-2), enclosed in zinc shield can 1 3/4" sq. x 4 1/2" high, phenolic base with six terminals	R-F selectivity band 2	M	3 E 7

TABULAR LIST OF REPLACEABLE PARTS FOR RADIO SET SCR-614-A

Ref. No.	Quan. in Equip.	Sig. Corps Stock No.	Name and Description of Part	Function	Mfg. Code and Type No.	Majestic Dwg. No.
#28	1		Transformer ass'y, R-F, 67.5-150 KC; includes trans. (101), one air trimmer (1-7), one temp. comp. (10-3), enclosed in zinc shield can 1 3/4" sq. x 4 1/2" high, phenolic base with six terminals	R-F selectivity band 3	M	3 E 9
#29	1		Capacitor, fixed, 10 mmf., ± 10%, 500 volts, ceramic, - .00033 T.C., 3/8" x 5/32" dia., axial leads	Coupling cap., R-F trans. band 3	C 813N	6 E 27
#30	1		Resistor, fixed, carbon, insulated, 100 ohm, ± 10%, 1/2 watt, 7/16" x 7/32", axial leads	Damping resistor R-F sec. band 2	AB EB-1011	9 E 21
#31-1	15		Capacitor, fixed, 100 mmf., ± 5%, 500 volts, ceramic, zero T.C., 7/8" x 5/32" dia., axial leads	Padder, h-f osc. band 1	C 810-305	6 E 12
#31-2		Capacitor, same as 31-1	Padder, h-f osc. band 3
31-3		Capacitor, same as 31-1, not replaceable, part of coil ass'y (92)	Trimmer, h-f osc. band 3
31-4		Capacitor, same as 31-1, not replaceable, part of trans. ass'y (51)	Trimmer, 2nd i-f trans.

31-5
31-6
31-7
31-8
31-9
31-10
31-11
#31-12
#31-13
#31-14
#31-15
#32-1	5
				6 E 10	C 813-161

Capacitor, same as 31-1, not replaceable, part of trans. ass'y (51)

Capacitor, same as 31-1, not replaceable, part of trans. ass'y (51)

Capacitor, same as 31-1, not replaceable, part of trans. ass'y (54)

Capacitor, same as 31-1, not replaceable, part of trans. ass'y (61)

Capacitor, same as 31-1, not replaceable, part of trans. ass'y (61)

Capacitor, same as 31-1, not replaceable, part of trans. ass'y (61)

Capacitor, same as 31-1, not replaceable, part of trans. ass'y (61)

Capacitor, same as 31-1

Capacitor, same as 31-1

Capacitor, same as 31-1

Capacitor, same as 31-1

Capacitor, fixed, 50 mmf., ± 10%, 500 volts, ceramic, zero T.C., 7/16" x 3/8" dia., axial leads

Trimmer, 2nd i-f trans.

Crystal balance cap.

Trimmer, crystal filter

Trimmer, 3rd i-f pri.

Trimmer, 3rd i-f pri.

Trimmer, 3rd i-f sec.

Trimmer, 3rd i-f sec.

Coupling cap., aux. diode

R-F by-pass, noise limiter

Plate by-pass, 1st a-f ampl.

Tuning cap., r-f pri.

Padder, h-f osc. band 2

TABULAR LIST OF REPLACEABLE PARTS FOR RADIO SET SCR-614-A

Ref. No.	Quan. in Equip.	Sig. Corps Stock No.	Name and Description of Part	Function	Mfr. Code and Type No.	Majestic Dwg. No.
#32-2		Capacitor, same as 32-1	Grid cap., h-f osc.
#32-3		Capacitor, same as 32-1	Grid cap., beat osc.
32-4		Capacitor, same as 32-1, not replaceable, part of trans. ass'y (61)	A. V. C. diode coupling
32-5		Capacitor, same as 32-1, not replaceable, part of trans. ass'y (61)	By-pass, detector diode
#33-1	7		Capacitor, air trimmer, 6.2 MMF. Min. cap., 107.7 MMF. Max. cap., 15 rotor, 15 stator plates, .016" air gap, ceramic mtg. base, 15/16" x 1 3/16" x 1 3/4", axial leads	Padder, h-f osc. band 2	AS Type 108-G	8 E 2
#33-2		Capacitor, same as 33-1	Padder, h-f osc. band 3
33-3		Capacitor, same as 33-1, not replaceable, part of coil ass'y (90)	Padder, h-f osc. band 1
33-4		Capacitor, same as 33-1, not replaceable, part of coil ass'y (91)	Trimmer, h-f osc. band 2
33-5		Capacitor, same as 33-1, not replaceable, part of coil ass'y (92)	Trimmer, h-f osc. band 3
33-6		Capacitor, same as 33-1, not replaceable, part of coil ass'y (43)	Trimmer, 1st i-f pri.

#33-7		
#34	1	Capacitor, same as 33-1, not replaceable, part of trans. ass'y (44)	Capacitor, same as 33-1, except for special mtg. post $1\frac{7}{32}$ " long	Capacitor, fixed, 20 mmf., $\pm 10\%$, 500 volts, ceramic, - .00075 T.C., $\frac{7}{16}$ " x $\frac{3}{16}$ " dia., axial leads, not replaceable, part of coil ass'y (90)	Capacitor, same as 35-1	Trimmer, 1st i-f sec. Padder, h-f osc. band 1 Temp. comp. h-f osc. band 1 Temp. comp., beat osc. Temp. comp., h-f osc. band 2 Temp. comp., h-f osc. band 3 Temp. comp., 1st i-f pri. Temp. comp., 1st i-f sec. Trimmer, h-f osc. band 1	AS Type 108-G C 811-039 C 807-068 C 807-075 A Type 1464	8 E 6 6 E 21 6 E 23 6 E 13 6 E 24
#35-2
36	1	Capacitor, fixed, 6 mmf., $\pm .5$ mmf., 500 volts, ceramic, - .00075 T.C., $\frac{7}{16}$ " x $\frac{3}{16}$ " dia., not replaceable, part of coil ass'y (91)	Capacitor, fixed, 3 mmf., $\pm .5$ mmf., 500 volts, ceramic, - .00047 T.C., $\frac{7}{16}$ " x $\frac{3}{16}$ " dia., not replaceable, part of coil ass'y (92)	Capacitor, same as 37-1, not replaceable, part of coil ass'y (43)	Capacitor, same as 37-1, not replaceable, part of trans. ass'y (44)	Capacitor, fixed, 1125 mmf., $\pm 2\%$, 500 volts, molded mica, $\frac{3}{4}$ " sq., wire leads, not replaceable, part of coil ass'y (90)
37-1	3
37-2
37-3
38	1

Generated on 2015-10-01 05:12 GMT / http://hdl.handle.net/2027/uc1.b3243881
Public Domain, Google-digitized / http://www.hathitrust.org/access_use#pd-google

ALBULAR LIST OF REPLACEABLE PARTS FOR RADIO SET SCR-614-A

Ref. No.	Quan. in Equip.	Sig. Corps Stock No.	Name and Description of Part	Function	Mfr. Code and Type No.	Majestic Dwg. No.
39	1		Capacitor, fixed, 300 mmf., ± 5%, 300 volts, molded mica, 1/16" x 7/16", not replaceable, part of coil ass'y (91)	Trimmer, h-f osc. band 2	A Type 1469	6 E 25
#40	1		Resistor, fixed, carbon, insulated, 10,000 ohms, ± 10%, 1/2 watt, 7/16" x 7/32", axial leads	Audio attenuator, a-f output tube	SC MB 1/2	9 E 17
#41-1	2		Resistor, fixed, carbon, insulated, 1,000 ohms, ± 10%, 1/2 watt, 7/16" x 7/32", axial leads	Cathode bias, tuning ind.	AB EB 1021	9 E 38
#41-2		Resistor, same as 41-1	Cathode bias, r-f ampl.
#42-1	7		Resistor, fixed, carbon, insulated, 47,000 ohms, ± 10%, 1/2 watt, 7/16" x 7/32", axial leads	Grid resistor, h-f osc.	SC MB 1/2	9 E 3
#42-2		Resistor, same as 42-1	Plate isolation, beat osc.
#42-3		Resistor, same as 42-1	Voltage divider, r-f ampl. screen
#42-4		Resistor, same as 42-1	Filter, aux. diode
#42-5		Resistor, same as 42-1	Filter, aux. diode
#42-6		Resistor, same as 42-1	Grid resistor, converter

#42-7	Resistor, same as 42-1	Voltage divider, 1st i-f ampl. screen
#43	I	Coil ass'y, 455 KC; includes coil (105), one air trimmer (33-6), one temp. comp. (37-2), enclosed in zinc shield can 1 3/4" sq. x 4 1/2" high	Plate load, converter	M 3 E 18
#44	I	Transformer ass'y, 455 KC; includes trans. (106), one air trimmer (33-7) one temp. comp. (37-3), enclosed in zinc shield can 1 3/4" sq. x 4 1/2" high, phenolic base with six terminals	1st i-f trans.	M 3 E 19
#45	I	Resistor, fixed, wire wound, 4,000 ohms, ± 5%, 5 watt, 2 9/16" x 1 3/16", rigid terminals for clamp contacts, Special	Voltage regulator resistor	L RE-13-372-J 9 E 19
46	This ref. no. not used		
#47	I	Capacitor, fixed, .1 mf., +14% -6%, 400 volts, paper, oil-filled, 1 3/4" x 1" sealed metal housing, terminal lugs, Type CA-166	Screen by-pass, 1st i-f ampl.	A 6 E 3
#48	I	Resistor, fixed, carbon, insulated, 270 ohms, ± 10%, 1/2 watt, 7/16" x 7/32", axial leads	Cathode bias, 2nd i-f ampl.	SC MB 1/2 9 E 6

TABULAR LIST OF REPLACEABLE PARTS FOR RADIO SET SCR-614-A

Ref. No.	Quan. in Equip.	Sig. Corps Stock No.	Name and Description of Part	Function	Mfr. Code and Type No.	Majestic Dwg. No.
49-1A, B	3		Capacitor, dual trimmer, 7.1 MMF. Min. cap. per sect., 44 MMF. Max. cap. per sect., 11 stator, 10 rotor plates, ceramic mtg. base, 1 3/8" x 1 13/16" x 1 3/4", not replaceable, part of trans. ass'y (51)	1-A Trimmer, 2nd i-f trans., pri. 1B-Crystal balance adj. cap.	TE Type AP-15L	8 E 1
49-2A, B		Capacitor, same as 49-1A, B, not replaceable, part of trans. ass'y (54)	2A-Crystal phase adj. cap. 2B-Trimmer, crystal filter
49-3A, B		Capacitor, same as 49-1A, B, not replaceable, part of trans. ass'y (61)	3A-Trimmer, 3rd i-f trans. pri. 3B-Trimmer, 3rd i-f trans., sec.
50-1	2		Capacitor, fixed, 80 mmf., ± 10%, 500 volts, ceramic, 1 3/16" x 3/16" dia., zero T.C., not replaceable, part of trans. ass'y (51)	Crystal balance cap.	C 810S-379	6 E 22
50-2		Capacitor, same as 50-1, not replaceable, part of trans. ass'y (54)	Crystal filter fixed cap.

#51	I	Transformer ass'y, 455 KC; includes trans. (107), one dual air trimmer (49-1A, B) two fixed trimmers (31-4) and (31-5), two crystal balance caps. (31-6) and (50-1), enclosed in zinc shield can 1 7/8" x 1 3/8" x 4 1/2" high, phenolic base with six terminals	2nd i-f trans.	M	3 E 22
#52	I	Switch, 3-position rotary selector, shorting type contacts, ceramic insulation, 1 5/8" dia. x 1 9/64" long body, 1/4" dia. x 1 3/16" shaft, 3/8" x 3/8" bushing	Crystal selectivity switch	C Type 2501 BHXC- 6873X	11 E 6
#53	I	Crystal, ass'y, 455 KC, ± 100 cycles, "X" cut, moisture proof, water tight molded phenolic holder, 1 1/8" high x 1 3/16" wide x 1 1/32" deep with 2 tube pins for 2-prong socket	I-F filter	M	29 E 6
#54	I	Coil ass'y, 455 KC; includes coil (108), one dual air trimmer (49-2A, B), one fixed trimmer (31-7), one fixed cap. (50-2), enclosed in zinc shield can 1 7/8" x 1 3/8" x 4 1/2" high, phenolic base with six terminals	2nd i-f grid loading	M	3 E 21

TABULAR LIST OF REPLACEABLE PARTS FOR RADIO SET SCR-614-A

Ref. No.	Quan. in Equip.	Sig. Corps Stock No.	Name and Description of Part	Function	Mfr. Code and Type No.	Majestic Dwg. No.
#55	1		Coil, inductance, 455 KC, .116 millihenrys, 5 mmf. dist. cap., duolateral winding on adjust. iron core, mounted in Majestic coil framework on phenolic base with four terminals, enclosed in zinc shield can 2" dia. x 1 1/8" high	Adjustment for beat osc.	M	3 E 23
#56	1		Capacitor, fixed, 1,000 mmf., ± 2%, 500 volts, mica, 3/4" sq., tinned brass terminal leads	Grid tuning of beat osc.	S Type MKS	6 E 11
#57	1		Capacitor, air trimmer, 5.1 MMF. Min. cap., 55.5 MMF. max. cap., 1 section, 9 stator, 10 rotor plates, .020" air gap, ceramic mtg. base, 1 1/4" x 1 5/16" x 2 1/8", axial leads	Grid tuning of beat osc.	AS Type 55-L	8 E 5
#58-1	2		Resistor, fixed, carbon, insulated, 1 megohm, ± 20%, 1/2 watt, 7/16" x 7/32", axial leads	Grid resistor, tuning ind.	SC MB 1/2	9 E 18
#58-2		Resistor, same as 58-1	Plate resistor, tuning ind.
#59-1	2		Resistor, fixed, carbon, insulated, 390,000 ohms, ± 10%, 1/2 watt, 7/16" x 7/32", axial leads	Noise limiter threshold resistor	AB EB 3941	9 E 14

	Resistor, same as 59-1, not replaceable, part of trans. ass'y (61)	Diode det. load
59-2	Resistor, fixed, carbon, insulated, 470 ohms, $\pm 10\%$, $\frac{1}{2}$ watt, $\frac{7}{16}$ " x $\frac{7}{32}$ ", axial leads	Cathode bias resistor, converter	AB EB 4711
#60	1	Transformer ass'y, 455 KC; includes trans. (110), 1 dual trimmer (49-3A, B), 4 fixed caps., (31-8) (31-9) (31-10) (31-11), 1 coupling cap. (32-4), 2 load resistors (14-1) (59-2), 1 by-pass cap. (32-5), enclosed in zinc shield can $1\frac{7}{8}$ " x $1\frac{3}{8}$ " x $4\frac{1}{2}$ " high, phenolic base with six terminals	3rd i-f trans.	M
#61	1	Resistor, fixed, carbon, insulated, 1.2 megohms, $\pm 10\%$, $\frac{1}{2}$ watt, $\frac{7}{16}$ " x $\frac{7}{32}$ ", axial leads	Cathode bias, noise limiter	SC MB $\frac{1}{2}$
#62	1	Switch, rotary selector, 4 positions, shorting type contacts, ceramic insulation, $1\frac{5}{8}$ " dia. x $1\frac{9}{64}$ " long body, $\frac{1}{4}$ " dia. x $\frac{3}{8}$ " shaft, $\frac{3}{8}$ " x $\frac{3}{8}$ " bushing	Noise limiter switch	C Type 2501 'BHXC-6872X
#63	1	Resistor, fixed, carbon, insulated, 150,000 ohms, $\pm 10\%$, $\frac{1}{2}$ watt, $\frac{7}{16}$ " x $\frac{7}{32}$ ", axial leads	Noise limiter threshold resistor	SC MB $\frac{1}{2}$
#64	1	Resistor, fixed, carbon, insulated, 100,000 ohms, $\pm 10\%$, $\frac{1}{2}$ watt, $\frac{7}{16}$ " x $\frac{7}{32}$ ", axial leads	Grid volt. divider, tuning ind.	SC MB $\frac{1}{2}$
#65	1			9 E 8

TABULAR LIST OF REPLACEABLE PARTS FOR RADIO SET SCR-614-A

Ref. No.	Quan. in Equip.	Sig. Corps Stock No.	Name and Description of Part	Function	Mfr. Code and Type No.	Majestic Dwg. No.
66	1		Terminal, on AUXILIARY DIODE terminal panel (156), not replaceable	Aux. diode negative		Panel No. 24 E 2
67	1		Terminal, same as 66	Aux. diode gnd.		
68	1		Terminal, same as 66	Aux. diode positive		
#69	1		Resistor, fixed, carbon, insulated, 47,000 ohms, $\pm 5\%$, 2 watt, $1\frac{3}{8}$ " x $1\frac{1}{32}$ ", axial leads	A.V.C. delay	SR Case No. S 2085	9 E 12
#70-1	2		Capacitor, fixed, .05 mf., $\pm 10\%$, 600 volts, paper, oil-filled, sealed metal housing, $1\frac{11}{32}$ " x $1\frac{19}{32}$ ", axial leads	A.V.C. by-pass	F Type 6883-BA	6 E 16
#70-2		Capacitor, same as 70-1	Tone control		
#71-1	2		Capacitor, fixed, .01 mf., $\pm 20\%$, 600 volts, paper, oil-filled, sealed metal housing, 1" x $1\frac{13}{16}$ "	Diode coupling cap.	F Type A7277	6 E 18
#71-2		Capacitor, same as 71-1	Coupling cap., 1st a-f ampl.		
#72	1		Resistor, variable, 2 megohms, $1\frac{1}{8}$ " O.D., $\frac{1}{4}$ " shaft, $\frac{3}{8}$ "-32 bushing	Volume control	CT #35 series	13 E 1
#73	1		Resistor, fixed, carbon, insulated, 3900 ohms, $\pm 5\%$, $\frac{1}{2}$ watt, $\frac{7}{16}$ " x $\frac{7}{32}$ ", axial leads	Cathode bias, 1st a-f ampl.	SC MB $\frac{1}{2}$	9 E 16

#74-1	2	Capacitor, fixed, 1.9 mf., +14% -6%, 200 volts, paper, oil-filled, 2" x 2", sealed metal housing, terminal lugs. Type CA-209	Cathode by-pass 1st a-f ampl.	A	6 E 1 †SC-D-512
#74-2	Capacitor, same as 74-1	Cathode by-pass, a-f output tube
#75	1	Resistor, variable, 1 megohm, 1/8" O.D. 1/4" shaft, 3/8"-32 bushing	Tone control	CT	14 E 1
#76	1	Switch, S.P.D.T., 2-position toggle, 1" x 1/2" x 1 7/8", 1 1/2 amps. at 250 V., 3 amps. at 125 V., bushing 1 5/32"-32	Power on-off	CH #8282	11 E 2
#77	1	Resistor, fixed, carbon, insulated, 360 ohms, ± 5%, 1 watt, 7/8" x 9/32", axial leads	Cathode bias, a-f output tube	SC MB 1	9 E 15
#78-1	2	Capacitor, fixed, .004 mf., ± 10%, 400 volts, molded paper, oil-filled, 3/4" x 3/4", axial leads	Filter, a-f output	TD Type DP	6 E 26
#78-2	Capacitor, same as 78-1	Filter, a-f output
#79	1	Choke coil, 477 millihenrys, ± 2%, 35 ma. D-C, 5 volts A-C, 400 cycles, 1 1/2" x 1 29/64" O.D.	Filter, a-f output Filter, a-f output	M	12 E 5
#80	1	Transformer, output, audio, 2 sections vacuum impregnated coil wound on laminated iron core, shell type, pri. to present 7500 ohms impedance when loaded on any sec. at the rated impedances shown on terminals (82) to (86), metal case 3 1/2" x 2 13/16" x 3 1/2" high	A-F output trans.	S Stancor 275A19	12 E 2

TABLE LIST OF REPLACEABLE PARTS FOR RADIO SET SCR-614-A

Ref. No.	Quan. in Equip.	Sig. Corps Stock No.	Name and Description of Part	Function	Mfr. Code and Type No.	Majestic Dwg. No.
#81	1		Phone jack, single closed circuit, 250 ohms, female jack, fits in 3/8" mtg. hole, 1 3/8" long, bushing 3/8" x 3/8", to fit standard signal corps head phone plug	Audio outlet, phone jack for head phones	CT Type J-259	18 E 1
82	1		Terminal, on OUTPUT terminal panel (128), not replaceable	4000 OHMS to GROUND output	Panel No. 24 E 1
83	1		Terminal, same as 82	250 OHMS balanced to ground
84	1		Terminal, same as 82	GROUND terminal
85	1		Terminal, same as 82	250 OHMS balanced to ground
86	1		Terminal, same as 82	250 OHMS to GROUND
#87-1	2		Resistor, fixed, carbon, insulated, 39 ohm, ± 5%, 1 watt, 7/8" x 9/32", axial leads	Pilot light voltage dropping resistor	SC MB 1	9 E 20
#87-2		Resistor, same as 87-1	Same		
88		<i>This ref. No. not used</i>			

#89	1	Receptacle, power, 6-pole, male, 2 #12 and 4 #16 pins, mounts in hole 1 5/8" dia., as per Spec. AN-W-C-591	Connect power unit to receiver	AP AN-3102 22-5P	15 E 2
#90	1	Coil ass'y, 470-485 KC; one tapped coil (102), one air trimmer (33-3), one fixed trimmer (38), one temp. comp. cap. (35-1), enclosed in zinc shield can 1 3/4" sq. x 4 1/2" high, phenolic base with six terminals	Grid inductance, h-f osc. band 1	M	3 E 12
#91	1	Coil ass'y, 485-522 KC; one tapped coil (103), one air trimmer (33-4), one temp. comp. cap. (36), one fixed trimmer (39), enclosed in zinc shield can 1 3/4" sq. x 4 1/2" high, phenolic base with six terminals	Grid inductance, h-f osc. band 2	M	3 E 13
#92	1	Coil ass'y, 522-605 KC; one tapped coil (104), one air trimmer (33-5), one fixed trimmer (31-3), one temp. comp. (37-1), enclosed in zinc shield can 1 3/4" sq. x 4 1/2" high, phenolic base, six terminals	Grid inductance, h-f osc. band 3	M	3 E 14
93	1	Transformer, R-F, single pri. shielded from two-section sec., mutual induc. 4.25 mhs., sec. induc. 280 mhs., dual lateral windings on pwd. iron core encased in pwd. iron shell. Not replaceable, part of trans. ass'y (7)	Ant. input, band 1	M	3 E 15

TABULAR LIST OF REPLACEABLE PARTS FOR RADIO SET SCR-614-A

Ref. No.	Quan. in Equip.	Sig. Corps Stock No.	Name and Description of Part	Function	Mfr. Code and Type No.	Majestic Dwg. No.
94	1		Transformer, R-F, single pri. shielded from two-section sec., mutual induc. .875 mhs., sec. induc. 70.6 mhs., duolateral windings on pwd. iron core encased in iron shell. Not replaceable, part of trans. ass'y (8)	Ant input, band 2	M	3 E 10
95	1		Transformer, R-F, single pri. shielded from two-section sec., mutual induc. .039 mhs., sec. induc. 14.9 mhs., duolateral windings on pwd. iron core encased in pwd. iron shell. Not replaceable, part of trans. ass'y (9)	Ant. input band 3	M	3 E 11
96	1		Coil, described under ref. (23)	Plate load, r-f ampl. band 1	M	3 E 16
97	1		Coil, described under ref. (24)	Plate load, r-f ampl. band 2	M	3 E 6
98	1		Coil, described under ref. (25)	Plate load, r-f ampl. band 3	M	3 E 8
99	1		Transformer, R-F two sections, mutual induc. 85 mhs., pri. induc. 64.5 mhs., sec. induc. 290.7 mhs., duolateral windings on pwd. iron core encased in pwd.	R-F section, band 1	M	3 E 17

100	I	iron shell. Not replaceable, part of trans. ass'y (26) Transformer, R-F, two sections, mutual induc. 37.9 mhs., pri. induc. 38.5 mhs., sec. induc. 94.5 mhs., duolateral windings on pwd. iron core encased in pwd. iron shell. Not replaceable, part of trans. ass'y (27)	R-F section, band 2	M	3 E 7
101	I	Transformer, R-F, two sections, mutual induc. 11.15 mhs., pri. induc. 14.65 mhs., sec. induc. 18.55 mhs., duolateral windings on pwd. iron core encased in pwd. iron shell. Not replaceable, part of trans. ass'y (28)	R-F section, band 3	M	3 E 9
102	I	Coil, inductance, 108 microhenrys overall induc., 9.33 mmf. dist. cap., duolateral windings mounted in Majestic coil framework on phenolic base, six terminals. Not replaceable, part of (90)	Osc. induc. band 1	M	3 E 12
103	I	Coil, inductance, 237 microhenrys overall induc., 8.66 mmf. dist. cap., duolateral windings mounted in Majestic coil framework on phenolic base, six terminals. Not replaceable part of (91)	Osc. induc. band 2	M	3 E 13

LAR LIST OF REPLACEABLE PARTS FOR RADIO SET SCR-614-A

Ref. No.	Quan. in Equip.	Sig. Corps Stock No.	Name and Description of Part	Function	Mfr. Code and Type No.	Majestic Dwg. No.
104	1		Coil, inductance, 286 microhenrys over all induc., 9 mmf. dist. cap., duolateral windings mounted in Majestic coil framework on phenolic base, six terminals. Not replaceable, part of (92)	Osc. induc. band 3	M	3 E 14
105	1		Coil, 1.090 mhs. induc., 6 mmf. dist. cap. duolateral winding on pwd. iron core, mounted in Majestic coil framework on phenolic base, six terminals. Not replaceable, part of (43)	Load coil, 1st i-f pri.	M	3 E 18
106	1		Transformer, single section pri. 1.275 mhs. induc., 2 winding sec. 1.16 mhs., mutual induc. .0125 mhs., duolateral winding on pwd. iron core, mounted in Majestic coil framework on phenolic base, six terminals. Not replaceable, part of trans. ass'y (44)	1st i-f trans.	M	3 E 19
107	1		Transformer, single section, pri. .45 mhs. induc., single section sec. .56 mhs. induc., mutual induc. .3 mhs., duolateral winding on pwd. iron core, mounted in Majestic coil framework on phenolic base,	2nd i-f trans.	M	3 E 21

108	1	six terminals. Not replaceable, part of trans. ass'y (51) Coil, induc., .452 mhs., duolateral winding on pwd. iron core, mounted in Majestic coil framework on phenolic base, six terminals. Not replaceable, part of coil ass'y (54)	Grid loading. 2nd i-f tube	M	3 E 22
109	1	Coil, described under ref. (55)	Beat osc. coil	M	3 E 23
110	1	Transformer, I-F, one section pri. and one section sec.; pri. induc. .475 mhs., sec. induc. .54 mhs., mutual induc. .017 mhs., two duolateral windings on two pwd. iron cores, mounted in Majestic coil framework on phenolic base with six terminals. Not replaceable, part of trans. ass'y (61)	3rd i-f trans.	M	3 E 20
111	This ref. No. not used			
#112-1	2	Lamp, pilot light, bayonet base, 1 watt, 6-8 volts	Pilot light	GE Mazda #47	26 E 2
#112-2	Lamp, same as 112-1	Same
113	1	Shield, .037 C.R. steel, 4 1/4" x 3 3/16" x 2 5/8". Not replaceable.	Beat osc. shield	EC Special	25 M 1
114	1	Shield, .037 C.R. steel, 2 1/2" x 2 1/2" x 2 1/4". Not replaceable.	Noise limiter shield	EC Special	25 M 3

TABULAR LIST OF REPLACEABLE PARTS FOR RADIO SET SCR-614-A

Ref. No.	Quan. in Equip.	Sig. Corps Stock No.	Name and Description of Part	Function	Mfr. Code and Type No.	Majestic Dwg. No.
#115	1		Shield, .037 C.R. steel, electro-zinc plate finish, 4 holes #16 drill, $6\frac{7}{32}$ " x $4\frac{15}{32}$ " x $2\frac{3}{4}$ "	Gang capacitor shield	PC Special	25 M 5
116	1		Shield, $\frac{1}{16}$ " thick C.R. steel, $6\frac{1}{2}$ " x $2\frac{3}{4}$ " x $1\frac{1}{2}$ ", not replaceable	Chassis shield	PC Special	25 M 4
117	1		Shield, zinc plate .0003 thick, $3\frac{1}{4}$ " x $2\frac{3}{4}$ " x 2"	Filter crystal shield	EC Special	25 M 2
#118	1		Cover, electro-zinc plate, $3\frac{1}{4}$ " x 2" x $2\frac{3}{32}$ "	Shield cover, filter crystal	EC Special	12 M 63
#119	2		Shield, zinc, $1\frac{3}{4}$ " sq. x $2\frac{13}{16}$ "	Shield for 12J5GT tubes	B Special	16 E 8
#120	1		Dial, calibrated, and hub ass'y, dial furnished with hub 11M19, dial $6\frac{1}{8}$ " O.D., hub $\frac{7}{8}$ " O.D. of brass, $\frac{1}{2}$ hard, black oxidized	Calibrated dial	CN 23663	17 M 1
#121	2		Socket, .025 C.R. steel, equipped with center contact, insulator and spring, and fibre sleeve, to fit miniature base bayonet bulb, $\frac{13}{16}$ " x $\frac{7}{16}$ ", 18" long leads, one bl. one wh., #22 stranded wire	Pilot light sockets	MF Special	15 E 8

#	Description	Crystal socket	CI	15 E 4
#122	Socket, crystal, black, mica-filled, to fit standard FT-243 crystal holder, $3\frac{5}{64}$ " x $5\frac{1}{64}$ "	Crystal socket	9816	15 E 4
#123	Socket, octal amphenol "S" with retainer ring, black bakelite, to fit #16 gauge chassis, $1\frac{1}{4}$ " dia., $\frac{1}{2}$ " deep	Tube sockets	AP S-8	15 E 9
#124	Grommet, black rubber or neoprene, $1\frac{1}{2}$ " O.D. x $\frac{3}{8}$ " thick	Grommet, tuning ind.	AIR 1919	13 M 1
#125	Grommet, rubber, $\frac{5}{16}$ " O.D.	In chassis	AP Special	13 M 2
#126	Grommet, rubber, $\frac{5}{8}$ " O.D., $\frac{1}{4}$ " I.D.	In chassis	AIR 97	13 M 4
#127	Cable assembly, cable connector with octal male plug, PM8-11, and octal female socket PF8-7 to fit octal tube base, cable, 6-conductor, #22 stranded wire insulated, 1 ea. black, white, brown, red, yellow, blue, $7\frac{3}{4}$ " long	Chassis to tuning ind. (V ₁₁)	M	35 E 1
#128	Terminal panel, black bakelite, zinc or silver plated, 5 screw terminals with solder lugs on back, 5 " x $1\frac{1}{2}$ " x $\frac{1}{8}$ " thick, black finish, white lettering	Output terminal connections	J 136-H	24 E 1
#129	Terminal board, bakelite, 2 terminals, $1\frac{1}{8}$ " x $\frac{3}{8}$ ", 1 mtg. foot, $\frac{3}{8}$ " mtg. centers	Mount res. & cap. in osc. circuit	NF	25 E 6

TABULAR LIST OF REPLACEABLE PARTS FOR RADIO SET SCR-614-A

Ref. No.	Quan. in Equip.	Sig. Corps Stock No.	Name and Description of Part	Function	Mfr. Code and Type No.	Majestic Dwg. No.
#130	1		Terminal board, XXE bakelite, wax impregnated, 2 terminals, $2\frac{3}{16}$ " x $\frac{1}{2}$ ", 1 mtg. foot, $\frac{1}{8}$ " mtg. centers, clearance for #6-32 screw	Mount caps. in beat osc.	NF	24 E 8
#131	1		Terminal board ass'y, XXE bakelite, 18 terminals, $\frac{4}{8}$ " x $\frac{1}{2}$ ", 3 mtg. pillars tapped #6-32 on $\frac{3}{8}$ " x $\frac{7}{8}$ " mtg. centers	Mount cap. & res. in det. & aux. diode circuits	M	24 E 21
#132	1		Terminal board ass'y, XXP bakelite, 10 terminals, $\frac{3}{4}$ " x $\frac{2}{8}$ ", 4 mtg. pillars tapped #6-32 on $\frac{2}{4}$ " x $\frac{3}{4}$ " mtg. centers	Mount cap. & res. in audio circuit	M	24 E 20
#133	1		Terminal board ass'y, XXP bakelite, 6 terminals, $\frac{2}{8}$ " x $\frac{1}{2}$ ", 2 mtg. pillars tapped #6-32 on $\frac{1}{2}$ " mtg. centers	Mount resistors	M	24 E 19
#134	1		Knob, with 2 cup pt. slotted head set screws, 3" dia. x $\frac{15}{16}$ " thick	FREQ. BAND knob	KK S-312-64B-L-BB	28 M 1
#135	1		Knob, with 2 cup pt. slotted head set screws, $\frac{2}{8}$ " dia. x $\frac{3}{8}$ " thick	TUNING knob	KK S-310-64-BB	28 M 2

#136	3	Knob, with 2 cup pt. slotted head set screws, 1 3/4" dia. x 27/32" thick	LIMITER, AUDIO GAIN, & AUDIO TONE knobs	KK S-381-64L-BB-DD	28 M 4
#137	2	Knob, with 2 cup pt. slotted head set screws, 1 3/4" dia. x 27/32" thick	BEAT OSC. PITCH & CRYSTAL SELECTIVITY knobs	KK S-381-64-BL-BB	28 M 5
*138	3	Tube, 12SK7, VT-131	R-F amp. (V ₁), 1st i-f ampl. (V ₄), 2nd i-f ampl. (V ₅)	K	1 E 1
*139	1	Tube, 12SA7, VT-161	Converter (V ₂)		1 E 2
*140	2	Tube, 12J5GT, VT-135	H-F osc. (V ₃), beat osc. (V ₁₀)	K	1 E 3
*141	1	Tube, 1629, VT-138	Tuning ind. (V ₁₁)	K	1 E 9
*142	2	Tube, 12H6, VT-214	Noise limiter (V ₆), Aux. diode (V ₇)	K	1 E 4
*143	1	Tube, VR 150-30, VT-139	Voltage regulator (V ₁₂)	RCA	1 E 7
*144	1	Tube, 12SQ7, VT-104	A-F ampl. (V ₈)	K	1 E 5
*145	1	Tube, 12A6, VT-134	Output (V ₉)	K	1 E 6
146	This ref. No. not used			

TABULAR LIST OF REPLACEABLE PARTS FOR RADIO SET SCR-614-A

Ref. No.	Quan. in Equip.	Sig. Corps Stock No.	Name and Description of Part	Function	Mfr. Code and Type No.	Majestic Dwg. No.
#147	8		Thumb screw, brass 1/2 hard, black oxidized, straight knurl, 1/4" long, head 5/16" high	Fasten escutcheon to front panel & gang cap. shield to cap	IM Special	11 M 28
148		This ref. No. not used			
#149	8		Thumb screw ass'y, screw 1/2 hard brass, black oxidized, 1" long; shoulder stud 17/32" O.D., 1/4" I.D., 9/16" long; cap 23/32" O.D., 19/32" I.D., 1/2" long, straight knurl	Fasten receiver to case	IM Special	11 M 25
#150	4		Thumb screw, 1/2 hard brass, 1/2" long	Fasten tube shields (119) to shield studs	H Special	11 M 22
151	22		Cap nut, #6-32 brass D.W.N., not replaceable	Fasten coil shields to trans.	H	2 M 3
152	6		Cap nut, #4-36 brass D.W.N., not replaceable	Fasten coil shields to trans.	H	2 M 5
153	2		Handle, mounted on front panel, steel, bonderized, black enamel, 45/8" x 1/2" dia., not replaceable	Front panel handle	RE	27 M 7

#	I	Mounting plate ass'y, XXE bakelite, 4 1/8" x 1" x 1/4" thick, 2 spacers, 2 fuse clips, 2 solder lugs, 2 ea. #10 lock-washer, hex. nut, 2 ea. #8 lockwasher, hex. nut	Mount res. (45)	M	24 E 13
155	I	Mounting bracket with spring clamp and wing screw, C.R. steel, 2 1/2" x 1 2/3", not replaceable	Mount tuning ind. (V ₁₁)	EC	12 M 9
#156	I	Terminal panel, 3 screw terminals with solder lugs on back, 3 1/2" x 1 1/2", black finish, white lettering	AUXILIARY DIODE panel	J 136A	24 E 2
157	I	Escutcheon, brass, bronze, or steel, 4 3/4" x 3 3/4" x 2 15/16", not replaceable	Covers dial on front panel	CN	22 M 1
158	I	Escutcheon gasket, neoprene, 1/32" thick, 1/2" wide on sides, 1/8" wide top & bottom, not replaceable	Between escutcheon & front panel	LR	22 M 2
#159	I	Terminal board ass'y, XXE bakelite, 18 terminals, 4 7/8" x 1 1/2", 4 mtg. pillars tapped #6-32 on 3 3/8" x 7/8" mtg. centers	Mount cap. & res.	M	24 E 22
160	This ref. No. not used			
#161	I	Connector plug, single contact, low-loss mica-filled bakelite insulation, 1 1/2" x 2 3/32" dia., Sig C No. PL-259	Connect whip ant. to adapter M-359	AP 83-1SP	18 E 9

TABULAR LIST OF REPLACEABLE PARTS FOR RADIO SET SCR-614-A

Ref. No.	Quan. in Equip.	Sig. Corps Stock No.	Name and Description of Part	Function	Mfr. Code and Type No.	Majestic Dwg. No.
#162	1		Adapter, single contact, high conductivity copper alloy pin contact on one end, socket contact on opposite end, pure polystyrene dielectric, Sig C No. M-359	Connect plug PL-259 to receptacle SO-239	AP 83-1AP	18 E 11
#163	1		Connector plug, twin contact, mica-filled bakelite insulation, 1 1/2" x 1 1/16" dia., Sig C No. PL-284	Connect long ant. to adapter PL-293	AP 83-22SP	18 E 10
#164	1		Adapter, twin contact, high conductivity copper alloy pin contacts on one end, socket contacts on opposite end, pure polystyrene dielectric, Sig C No. PL-293	Connect plug PL-284 to receptacle SO-264	AP 83-22AP	18 E 12
#165	4		MOUNTING FT-411-A Lord mounting, 2 3/8" sq. base x 1 1/8" high under rated load	Shock absorber	LM 153 PH-28	21 M 3
#166	4		Trunk catch, lock portion, steel, electro-zinc .0003	To fasten Case to Mounting	CC 15641	27 M 1-1
#167	4		CASE CS-109-A Trunk catch, hook portion, steel, electro-zinc .0003	To fasten Case to Mounting	CC 15641	27 M 1-2
168	1		Lid catch, parmetal, not replaceable	To fasten case lid	CC	27 M 10

POWER SUPPLY UNIT RA-61-A					
#201	1	Switch, S.P.D.T., 2-position toggle, 1 1/2 amps at 250 V., 2 amps at 125 V., 1 7/8" x 1" x 1/2"	Line volt. sw.	CH #8282	11 E 2
#202	4	Fuse, 1 1/2 amps at 230 V., 1 1/4" x 5/16" dia., (3 spares)	Line to trans.	B 3 AG	26 E 6
#203	4	Fuse, 3 amps at 115 V., 1 1/4" x 5/16" dia., (3 spares)	Line to trans.	B 3 AG	26 E 5
#204	1	Transformer, power, single winding tapped pri., 4 sec. windings, shell type, iron core, 13 tinned lugs, encased in metal case, 5" x 5" x 4"	Power trans.	S Stancor 275P26	2 E 1
#205	1	Switch, D.P.D.T., toggle, 1 1/2 amps at 250 V., 3 amps at 125 V., 2 15/64" x 1 5/16" x 3/4"	Heater volt. sw.	CH 8825K	11 E 1
#206-1	3	Capacitor, fixed, 8 mf., +20% -10%, 600 volts, paper, oil-filled, welded-steel aluminum finished can, 3 7/8" x 3 3/4" x 1 1/4", high tension pillar terminals fitted with lock nuts and solder lugs	Filter cap.	A 609	5 E 1
#206-2	Capacitor, same as 6-1	Filter cap.
#206-3	Capacitor, same as 6-1	Filter cap.

TABULAR LIST OF REPLACEABLE PARTS FOR RADIO SET SCR-614-A

Ref. No.	Quan. in Equip.	Sig. Corps Stock No.	Name and Description of Part	Function	Mfr. Code and Type No.	Majestic Dwg. No.
#207-1	2		Coil, filter choke, 10 henries with 0.12 amp d-c, 100 ohm, +5% — 10% d-c resistance, wound on iron core, 2 solder lugs, 4" x 4" x 4 1/2"	Filter reactor	S Stancor 275C12	12 E 1
#207-2		Coil, same as 207-1	Filter reactor
#208	1		Terminal strip, output, XXE bakelite, 8 solder lugs and screw terminals, 3 11/16" x 2 1/2" x 1/8"	Output terminals	J 136-A	24 E 5
208A	1		Terminal, on terminal strip (208), not replaceable	B+ terminal
208B	1		Terminal, same as #208A	To heater line
208C	1		Terminal, same as #208A	To power switch
208D	1		Terminal, same as #208A	To power switch
208E	1		Terminal, same as #208A	To heater line
208F	1		Terminal, same as #208A	B— terminal
208G	1		Terminal, same as #208A	To power line Cord CD-872
208H	1		Terminal, same as #208A	To power line Cord CD-872

#209-1	2	Capacitor, fixed, .01 mf., ± 20%, 600 volts, paper, oil-filled, tinned brass case, 1" x 1 3/16", #20 tinned copper wire leads 1 1/2" long, 1 terminal ground	R-F by-pass on power line	F A7237	6 E 5
#209-2	Capacitor, same as 209-1	R-F by-pass on power line
210	1	Plug, with coupling ring, not replaceable	Connect Cord CD-872 of power unit to receiver	AP AN-3108-22S-5S	15 E 11
#211	1	Cord ass'y, 10 ft., 2 conductor, bl. & wh. #18 (16 strands #30 tinned copper wire) type "S" or equivalent, CD-873, with standard male plug on one end	Connect power unit to power line	CW	35 E 3
#212	1	Cord ass'y, 7 ft., 6 conductor, shielded power cord, type "S" or equivalent, bl. & wh. conductors #14 (41 strands #30 tinned copper wire), red, green, blue, & yellow conductors #18 (16 strands #30 tinned copper wire) with 6-contact female connector AN-3108-22-5S, CD-872	Connect power unit output to receiver	E	35 E 4
#213	2	Socket, tube, octal with locking ring, black bakelite	For 5U4G tubes	AP Type S	15 E 14
#214	2	Tube, 5U4G, VT-244 (1 spare)	Rectifier	K	1 E 8
#215	1	Grommet, black rubber or neoprene, 3 1/32" x 9 3/32" O D	In chassis	AIR 1862	13 M 9

TABULAR LIST OF REPLACEABLE PARTS FOR RADIO SET SCR-614-A

Ref. No.	Quan. in Equip.	Sig. Corps Stock No.	Name and Description of Part	Function	Mfr. Code and Type No.	Majestic Dwg. No.
#216	1		Grommet, black rubber or neoprene, 1 1/2" x 3/8" O.D.	In chassis	AIR 1919	13 M 1
#217	2		Safety latch, .037 C.R. steel, electro-zinc plate .0003 thick	Lock trigger on switches (1) & (5)	SS Special	12 M 64
#218	4		Trunk catch, hook portion, steel	To hold power unit to Mounting FT-414	CC Special	27 M 1-2
#219	2		Thumbscrew, brass 1/2 hard, black oxidized, straight knurl, 1 1/16" long, head 5/16" dia.	Fasten safety clamp 12 M 64 to bracket	IM Special	11 M 28
#220	2		Fuse holder, 2 solder lugs, tinned hex. nut, rubber washer, bakelite knurled cap, 2 7/16" x 1 1/16" dia.	Connect power line to pri. of trans.	B HKM	26 E 4
221	2		Lid catch, parmetal, not replaceable	To fasten doors on back of unit	CC	27 M 10
222	2		Handle, mounted on front panel, steel, bonderized, black enamel, 4 5/8" x 1 1/2" dia., not replaceable	Front panel handle	RE	27 M 7

#223	4	MOUNTING FT-414 Lord mounting, 2 ³ / ₈ " sq. base x 1 ¹ / ₈ " high under rated load Trunk catch, lock portion, steel	Shock absorber To hold power unit to Mounting FT-414	LM 150PH15	21 M 2
#224	4			CC 15641	27 M 1-1

#Available in Depot Stock.

*Supplied with equipment as running spares.

†Signal Corps Drawing.

45. INDEX OF MANUFACTURERS

Abbrev.	Name	Address
A	Aerovox Corp.	New Bedford..... Massachusetts
AB	Allen-Bradley Co.	Milwaukee..... Wisconsin
AP	American Phenolic Co.	1930 S. 54th Ave..... Illinois
AS	American Steel Pkg. Co.	Defiance..... Ohio
AIR	Atlantic India Rubber Works, Inc.	1453 W. Van Buren St..... Illinois
B	Barnes Metal Works	4425 W. 16th St..... Illinois
C	Centralab.	900 E. Keefe Ave..... Wisconsin
CC	Corbin Cabinet Lock Co.	New Britain..... Connecticut
CH	Cutler Hammer Co.	Milwaukee..... Wisconsin
CI	Cinch Mfg. Co.	2335 W. Van Buren St..... Illinois
CN	Crowe Nameplate & Mfg. Co.	3700 Ravenswood Ave..... Illinois
CT	Chicago Telephone Supply	Elkhart..... Indiana
CW	Crescent Insulated Wire & Cable Co.	Trenton..... New Jersey
E	Essex Wire Co.	14310 Woodward Ave..... Michigan
EC	Erie Can Co.	816 W. Erie St..... Illinois
F	J. E. Fast Co.	3123 Crawford Ave..... Illinois
GE	General Electric Co.	Cleveland..... Ohio
H	H. M. Harper Co.	2620 W. Fletcher St..... Illinois
IM	Ideal Metal Products Co.	3231 W. Lake St..... Illinois
J	H. B. Jones Co.	2300 Wabansia Ave..... Illinois
K	Ken-Rad Tube & Lamp Co.	Owensboro..... Kentucky

KK	Kurz Kasch Co.....	Dayton.....	Ohio
L	Lectrohlm Inc.....	5733 W. 25th St.....	Illinois
LM	Lord Mfg. Co.....	Erie.....	Pennsylvania
LR	Lavelle Rubber Co.....	424 N. Woods St.....	Illinois
M	Majestic Radio & Television Corp.....	2600 W. 50th St.....	Illinois
MF	Micarta Fabricated Products.....	4619 Ravenswood Ave.....	Illinois
NF	National Fabricated Products.....	2600 Belden Ave.....	Illinois
PC	W. C. Paquette Mfg. Co.....	4444 N. Ravenswood Ave.....	Illinois
RC	Radio Condenser Co.....	Thorne & Copewood Sts.....	New Jersey
RCA	Radio Corporation of America.....	Harrison.....	New Jersey
RE	Real Equity Shop.....	1331 N. Wells St.....	Illinois
S	Standard Transformer Co.....	1500 N. Halsted St.....	Illinois
SC	Stackpole Carbon Co.....	St. Marys.....	Pennsylvania
SM	Solar Mfg. Co.....	Bayonne.....	New Jersey
SR	Speer Resistor Corp.....	St. Marys.....	Pennsylvania
SS	Service Sheet Metal Works.....	3962 Cottage Grove Ave.....	Illinois
TD	Tobe Deutschman Co.....	Canton.....	Massachusetts
TE	Teleradio Engineering Co.....	99 Wall St.....	New York

Order Nos. - 45-MPD-43, 467-MPD-43

November, 1943

Part No. 19M19-B

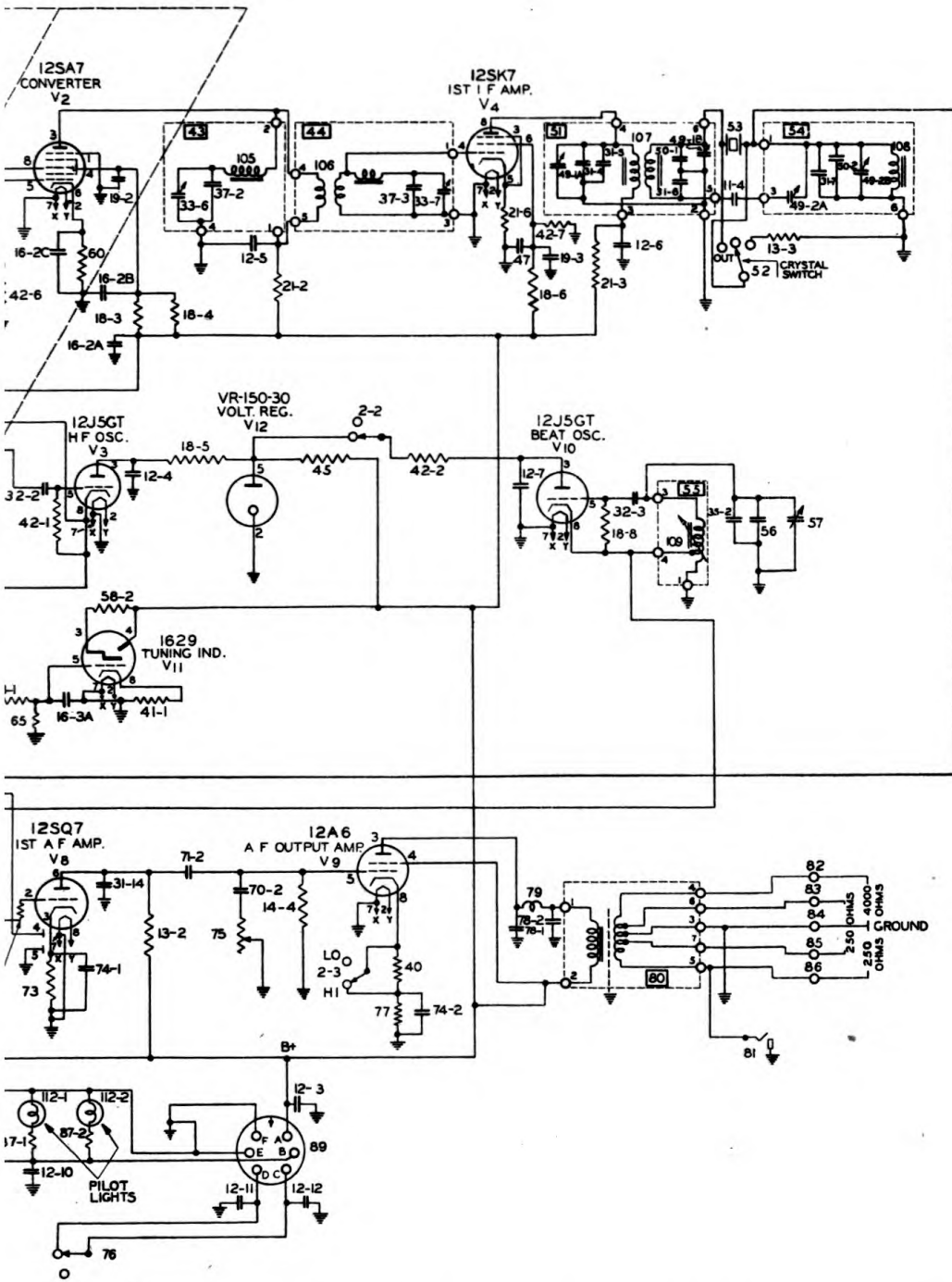

Figure 12 Radio Receiver BC-969-A schematic circuit diagram