

ACOM 1000

HF + 6m LINEAR AMPLIFIER



OPERATING MANUAL

Table of Contents

1. GENERAL INFORMATION	3
1-1. Introduction and Description	3
1-2. Owner Assistance	3
1-3. Equipment Supplied	3
1-4. Features	3
1-5. Safety Considerations, Explicit Definitions	4
2. INSTALLATION	6
2-1. Unpacking and Initial Inspection	6
2-2. Line Voltage Selection	6
2-3. Amplifier Location Selection	6
2-4. Connections	7
2-5. Installation of External Fan	9
3. POWER ON, CONTROLS AND INDICATORS	9
4. OPERATION	11
4-1. Turning ON and OFF	11
4-2. Changing Operate and Standby Modes	12
4-3. Tuning	12
4-4. ON LINE Information Screens and Control Functions.	15
4-5. Auto-Protection System	15
5. OFF LINE OPERATION	16
5-1. Contrast and Backlighting control	16
5-2. Auto-Operate enabling and disabling	16
5-3. Reading Auto-protection Signatures	16

6. MAINTENANCE	17
6-1. Cleaning	17
6-2. Fuses Replacement	17
6-3. Tube Replacement	17
6-4. The ACOM1000 Simplified Schematic Diagram	17
6-5. Troubleshooting	18
7. SPECIFICATIONS	20
7-1. Parameters	20
7-2. Functions	21
7-3. Storage and Shipment	21

I. GENERAL INFORMATION

I-1. Introduction and Description

This manual explains the installation, operation, and maintenance of the ACOM1000 HF+6 meters linear amplifier.

The ACOM1000 is a complete and self-contained linear amplifier that covers all amateurs bands from 1.8 through 54MHz and provides over 1000W-output power with less than 60W-exciter drive. Antenna VSWR up to 3:1 is acceptable at full power. Tuning is substantially simplified by a plate-load True Resistance Indicator (TRI) and by an automatically controlled input attenuator. Operating parameters are displayed by a multi-functional backlighted Liquid Crystal Display. Full break-in transmit/receive switching (QSK) is standard.

I-2. Owner Assistance

If assistance is needed, you should contact your local dealer first. If you still have an issue you need to discuss with one of ACOM's specialists, the contact information is as follows: fax + 359 2 920 96 56, tel. + 359 2 920 96 55, e-mail acom@mail.orbitel.bg or acom@aster.net or by mail: bul. Gornobanski Nr.151, 1330 Sofia, Bulgaria.

I-3. Equipment Supplied

The ACOM1000 amplifier and this manual are shipped in a cardboard carton.

I-4. Features

- Easy to operate. The TRI is a powerful tuning aid which, together with the automatically controlled input attenuator, helps the operator to quickly and precisely match antennas (5-10 seconds typically). The auto-operate function (when enabled) maintains the amplifier in OPERATE mode for you, thus saving manual operations and time.
- No heavy outboard antenna tuners required for antenna VSWR up to 3:1 (and higher on some bands). Your amplifier will perform the functions of an antenna tuner, thus enabling you to change antennas faster and use them over a wider frequency range (saving tuning time).
- An amplifier that is both user-friendly, and that looks after itself. It is designed to safely withstand up to 500W reflected power, up to 100 milliseconds duration of drive spikes, drive RF "tails" after a PTT or KEY release, operator's inadvertent tuning errors etc. It would also not cease to function with a "soft" AC line and would deliver more than half power at only 75% of nominal mains voltage. It would withstand up to 10 milliseconds (down to zero) voltage drops, and up to +15% line voltage spikes, which is important particularly when used at field days, DXpeditions, and other portable events.
- LCD comment display. All amplifier status indications are explained via detailed text displayed on the dot matrix backlighted liquid crystal display (LCD). The upper-line's strip on the LCD always reads directly peak forward power. LED indicators are provided for OPERATE, attenuation-on, and ON/OFF conditions.
- Easy maintenance. Signatures of the amplifier internal status are stored in a nonvolatile memory for 7 most recent auto protection trips. This information can be forwarded to your dealer for diagnostics. Using an EXCEL APPLICATION (available from ACOM or your dealer free of charge) and a PC you can

decode the signatures by yourself, too.

- Less noise in the shack: the input bypassing and the vacuum antenna relays are virtually silent even in QSK CW mode due to their special mounting.
- Less QRM and improved Electro Magnetic Compatibility during tuning. Antenna matching can be achieved in less than 10 seconds at a quarter of nominal output power.
- Operates without special signals from the transceiver - “ground on TX” and 60W RF drive power are sufficient.
- Broadband input matching circuit resulting in very good load to the transceiver over the entire spectrum from 1.8MHz up to 54MHz.
- Uses a single 4CX800A (GU74B) Svetlana high-performance ceramic-metal tetrode with plate dissipation of 800W (forced air cooling, grid-driven).
- Permanent monitoring and protection of plate and grid voltages and currents, as well as of the exhaust air temperature. The Bias Optimizer decreases the heat dissipated from the tube, and there is automatic protection against overheating in accordance with the specifications of the tube producer.
- An output RF Arc protection is employed. It safeguards the amplifier, antenna, antenna selector, and tuner against severe damage in case of possible break down.
- High voltage power supply inrush current protection, which eliminates the danger of affecting sensitive devices, connected to the same mains circuit (important when used portable). The amplifier can be configured for 5 nominal line voltages: 200, 210, 220, 230, and 240VAC, 50 or 60Hz (100, 110, and 120VAC on request).
- Continuous measuring and/or selectable monitoring of 12 most important parameters of the amplifier, exciter and antennas via LCD.
- The amplifier can be shipped with 10 and 12 meters capability disabled as required by the FCC for US users. Contact your dealer about enabling those bands.

I-5. Safety Considerations, Explicit Definitions

The ACOM1000 HF+6 meters Linear Amplifier is a Safety Class I unit. The third grounding lead of its mains cord (which is colored yellow with two green stripes) and the ground stud on the rear panel of the amplifier, (marked GND) must be connected to the station’s grounding system for safe operation.

The amplifier is designed to meet international safety standards and complies with CE safety and electromagnetic compatibility requirements, as well as FCC regulations.

This operating manual contains information, precautions, indications for cautions and warnings which must be followed by the user to ensure safe operation and to keep the ACOM1000 in safe operating condition.

PRECAUTIONS:

The EXPLICIT DEFINITIONS described below apply to this operating manual:

WARNING notes call attention to a procedure which, if not correctly performed, could result in personal injury, fire hazard or electric shock.

CAUTION notes call attention to a procedure which, if not correctly performed, could result in equipment damage, not only in the amplifier.

NOTE notes call attention to a procedure which, if not correctly performed, could result in inconvenience.

WARNING HIGH VOLTAGE!

The amplifier works with high voltages up to 3000V, which are **LETHAL!** Also, for your safety, pull the amplifier power plug out of the mains wall outlet and **WAIT AT LEAST 30 minutes EACH TIME BEFORE** you remove the cover of the amplifier. Do not touch any part inside while the amplifier is open because some residual voltages may still be present.

WARNING HIGH VOLTAGE!

NEVER ALLOW ANYONE, ESPECIALLY CHILDREN,

to push anything into holes in the case - this will cause electric shock. **NEVER TOUCH AN ANTENNA** during transmission - this may result in an electric shock or burn. **NEVER EXPOSE** the amplifier to rain, snow or any liquids. **AVOID** placing the amplifier in excessively dusty environments or in direct sunlight. **DO NOT OBSTRUCT AIR INTAKE** (rear panel) and **EXHAUST** (top cover) areas of the amplifier. Keep a minimum distance of 10cm (4 inches) to the intake and 50cm (20 inches) to the exhaust.

WARNING

Do not undertake on your own repairs or changes in hardware or software of the amplifier. Otherwise you may endanger your or other's health and life or damage the amplifier and the equipment connected with it, not covered by warranty. The manufacturer is not liable for another's actions and responsibility shall be assumed by the doer.

CAUTION

To avoid damage (not covered under warranty) read the Installation - Section 2 of this operating manual carefully. If you have any doubts about the installation, operation or safeties of the amplifier please consult your dealer.

2. INSTALLATION

2-1. Unpacking and Initial Inspection

NOTE

Before you start to install the amplifier, thoroughly read this manual. First, carefully inspect the cardboard carton and its contents for physical damage. If damage is noticed, notify your dealer immediately. Delay may infringe carrier's warranty conditions. Keep all packing for possible future transportation!

2-2. Line Voltage Selection

CAUTION

To avoid damage (not covered under warranty), check carefully if the voltage for which the amplifier is set corresponds to your mains nominal voltage.

Normally the amplifier is supplied set for a nominal line voltage of 240V. There might be exceptions in cases of special delivery and then the voltage set is noted in the Table of Individual Data (Table 2-1). If your power line has a different nominal voltage, it will be necessary for you to contact your dealer.

AMP s/n	
Tube s/n	
Voltage Selector	VAC

Table 2-1. ACOM 1000 Individual Data

2-3. Amplifier Location Selection

CAUTION

The weight of the unit is about 22kg, which should preferably be handled by two persons.

Position the amplifier near the place where it will be used. You'll need an easy access to the command knobs and indicator's area, as well as to the rear panel cabling.

No magnetic-field sensitive devices should be located next to the right side of the amplifier as its power transformer is located there. It's best to position it to the right of your transceiver. No temperature sensitive devices should be located above the exhaust hot air area, so don't push it under a shelf. You may prefer to use the bottom scales of both variable capacitor knobs (TUNE and LOAD) if you install it on a shelf. **DO NOT OBSTRUCT AIR INTAKE** (rear panel) and **EXHAUST** (top cover) areas of the amplifier. Keep a minimum distance of 10cm (4 inches) to the intake and 50cm (20 inches) to the exhaust.

2-4. Connections

Connection to your station must be accomplished in the order described below, before you apply mains voltage to the amplifier.

WARNING

Note that the grounding system may have to withstand currents over 10A with insignificant voltage drop on it. Therefore, it may be necessary to improve it considerably, i.e. to become less resistive, with heavier leads and lower-resistive ground path. The grounding leads should be at least 4mm² (AWG 11 or SWG 13).

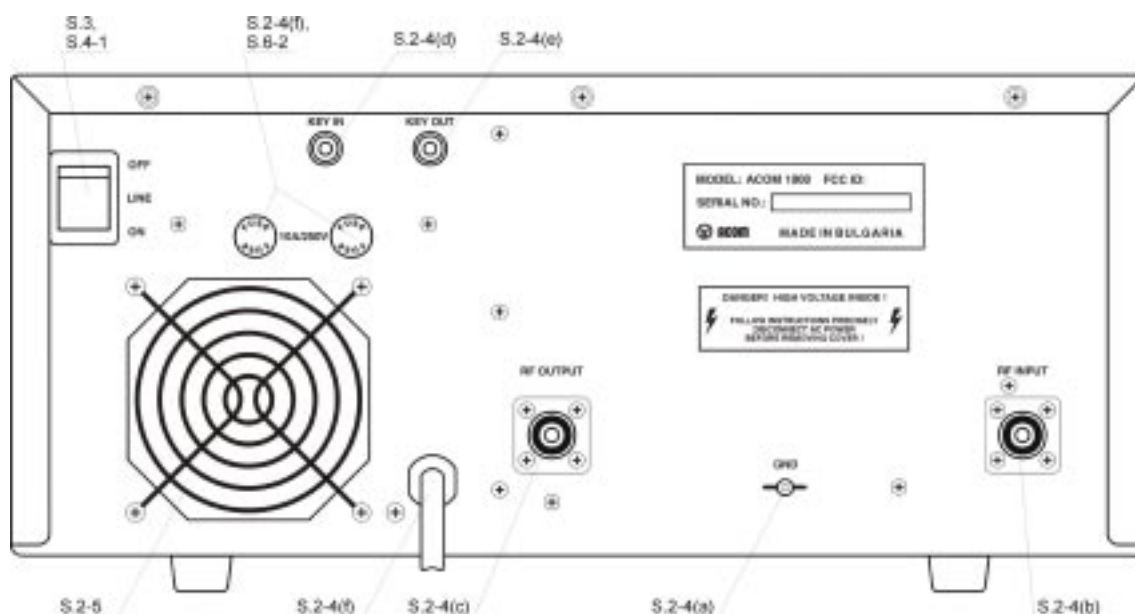

Fig.2-1 Connections

- a) First, connect the ground stud of the amplifier (on the rear panel, marked GND) to the station's grounding system (Fig.2-1).
- b) Connect a coaxial cable with a PL-259 plug from the transceiver output to the amplifier rear panel RF INPUT socket.

CAUTION

If this is the first time you will use a power amplifier in your station, pay attention to the coaxial cable type from the amplifier's output. It must handle the increased power safely, particularly on the 10 and 6 meters bands. We recommend, that you use RG213 or better. Check the same for the antenna selector and tuner as well as the antenna itself (especially multi-band trap antennas).

- c) Connect a coaxial cable from the amplifier output (on the rear panel, marked RF OUTPUT) with a PL-259 plug to the antenna selector or tuner or to the antenna for the respective band.
- d) Run a cable terminated in a Phono (RCA) connector from the transceiver socket providing "ground on transmit" to the amplifier rear panel KEY-IN socket.

NOTE

Your amplifier will not work if KEY-IN is not connected properly.

Transceiver producers give different names to this output and they are for instance TX-GND, SEND, T/R-LINE, etc. Some transceivers require that “ground on transmit” is implemented via a software command, or by changing the setting of a switch on the rear panel, or interior of the transceiver. Check your transceiver’s manual.

e) The KEY-OUT socket on the rear panel provides an extra control signal from the amplifier to the transceiver. It could be used to improve the transmit/receive switching safety.

If your transceiver has a suitable input that disables transmission, we recommend that you connect it with a cable terminated in a Phono (RCA) connector to the KEY-OUT socket of the amplifier. Transceiver producers give different names to this input and they are for instance TX-INHIBIT, MUTE, LINEAR, etc. Check your transceiver’s manual or consult your dealer.

If your transceiver does not have such input, don’t worry - the amplifier will function normally as well, and then the KEY-OUT may remain unused.

f) Preparation of wall outlet for the amplifier.

WARNING

If your amplifier is only fitted with one mains fuse, it is suitable for 0-220...240 VAC electricity supplies ONLY (these supplies are standard in the European Community). Your dealer will check that your amplifier is correctly fused before it is shipped to you. Customers should check with a qualified electrician if the amplifier is to be used outside the country in which it was purchased.

Due to the different standards in different countries, the mains plug is supplied and mounted by the dealer. He connects to the mains cord end a standard mains supply plug which meets the Safety Class I units standard in your country. The ground lead of the amplifier’s power cord is colored yellow with two green stripes and the blue and brown leads are active. When the amplifier is to be used with only one mains fuse, it is connected in series with the brown lead, which must be the active. If you have any doubts about the correct way of connecting the wires, consult your dealer.

WARNING

Before connecting the amplifier to your mains supply, be sure that the supply is correctly wired, and is adequate for the current drawn by the amplifier (up to 10A). Make certain that the grounding lead is connected properly in the wall outlet for the amplifier.

It is preferable that you use the wall outlet closest to the source. The installation leads should be at least 1.5mm² (AWG 15 or SWG 17). Check if the respective fuses can handle current up to 10A, as well, as if the voltage corresponds to the voltage for which the amplifier is set (S.2-2). If you connect the amplifier to a different mains outlet, be sure that you check it, too.

Make sure the main Power Switch on the rear panel is in OFF position and insert amplifier’s mains plug into the wall outlet prepared for it. The amplifier remains switched off.

2-5. Installation of External Fan

This fan (Fig. 2-1) is not necessary in SSB and CW modes, nor in continuous carrier modes (RTTY, SSTV etc.) with carrier down times of maximum 15 minutes and a subsequent pause of 3 minutes. For higher duties or ambient temperatures the fan is recommended. The auxiliary fan (92x92mm) must be brushless type, 2...5W/24VDC. It may be installed by your dealer or by the manufacturer on request.

3. POWER ON, CONTROLS AND INDICATORS

CAUTION

Do not turn the amplifier on for at least 2 hours after unpacking it in the room where it will be used. Pay particular attention when you move it from a very cold into a very warm place - condensation is likely and this could result in damage to the high voltage circuits. In such a case, wait at least 4 hours. A similar effect can occur after a rapid warming of the operating room (for instance after switching on a powerful heater in a cold shack).

CAUTION

To avoid damage (not covered under warranty) carefully check that the voltage for which the amplifier is set corresponds to your mains nominal voltage (see S.2-2 and table 2-1).

After following all instructions in S.2, you can turn ON the main power switch marked "LINE" on the rear panel (Fig.2-1). The red LED indicator above the red ON/OFF button located on the front panel must light red and a black inscription "ACOM1000" will appear on the LCD (Fig.3-1):



Fig.3-1 ACOM1000 Display and Control

You'll note that the upper line of the LCD always reads directly peak forward power, even while the tube is not driven. The 1200W scale resolution is 10W per bar, dots division weight is 60W, and figures are multiple to 300W. Note also that levels below 20W may be not detected.

NOTE

If the characters on the LCD are dim or not readable, please follow the method of LCD contrast and backlighting adjustment described in S.5-1.

In this position (called OFF LINE hereafter) only the micro-controller is operational, while the amplifier itself is still turned off (the tube is not powered at all).

The control of the amplifier is accessible during OFF LINE and ON LINE states, each having several information screens and control functions (see Fig.3-2):

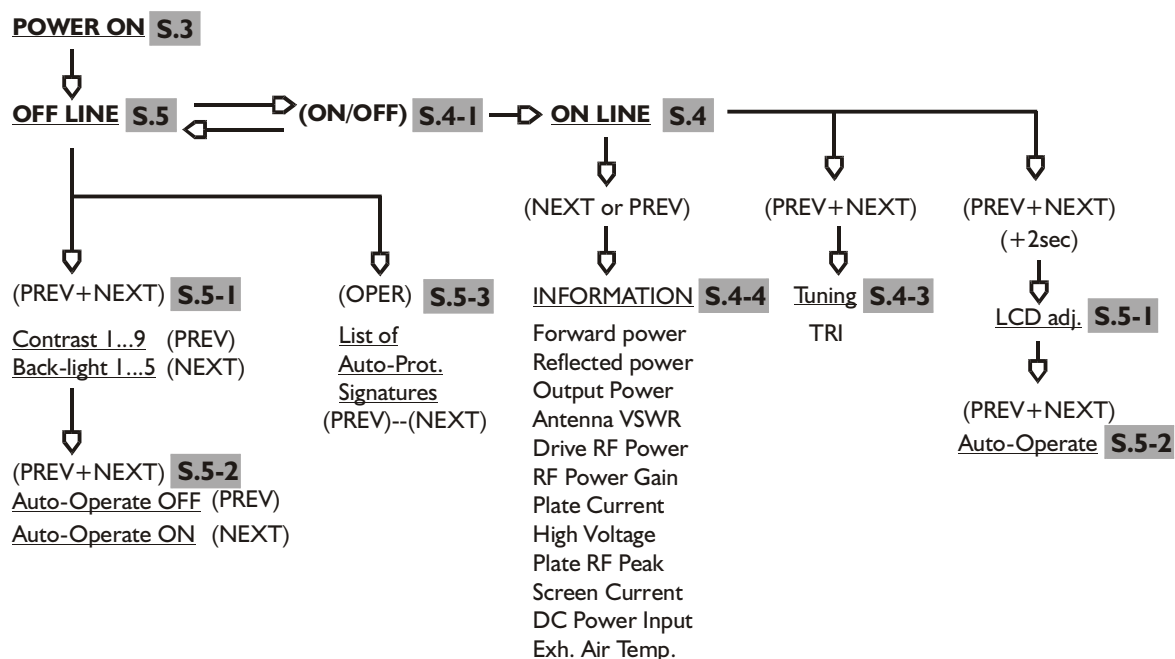

Fig.3-2 Information Screens and Control Functions Structure

The OPER button alternatively changes operate and standby modes (S.4-2) while ON LINE. Please note that Auto-Operate might be enabled. The same button activates signature list while OFF LINE.

The PREV and NEXT buttons change information screens or select control functions (S.4-4) for both OFF LINE and ON LINE.

The ON/OFF button alternatively switches OFF LINE and ON LINE states of the amplifier.

You can proceed in one of two directions:

a) You can use the OFF LINE information screens and control functions. They refer to the auto-protection signatures list, LCD contrast and backlighting control, as well as the Auto-Operate feature. This is described in S5.

b) You can turn on the amplifier and begin the warm-up sequence. After 2.5 minutes you may tune and start operating the amplifier and you can use the ON LINE information screens or control functions (see below).

4. OPERATION

Operation of the amplifier is simplified due to the TRI tuning aid, Auto-Operate function, and automatic protection system, so you'll be able to begin using it immediately after the installation. However, to make full use of amplifier's potential and to fully configure it to your local conditions, we recommend that you thoroughly read the following information.

There are 14 ON LINE information screens, which can be selected by pressing repeatedly the NEXT or PREV buttons (see fig.3-2). Their purpose and method of use are described in the next five sections 4-1 through 4-5.

4-1. Turning ON and OFF

In order to turn on the amplifier, while the Main Power Switch (located on the rear panel) is on, press the red ON/OFF button (on the front panel right-bottom corner) and hold it on for about 1 second. The LCD backlight will light and the ON/OFF LED indicator above the button will change from red to green. You'll hear the blower start first at high speed, then slow down.

After successfully passing the initial self-tests, the ON/OFF LED begins flashing green while the following inscription on the LCD remains lit:

WARMING UP: nnn s

(nnn above is the number of seconds remaining to readiness for operation)

A tube warm-up period of 2.5 minutes follows. During this time the amplifier remains in standby mode, so you can continue operating with the transceiver.

Pressing either the PREV or NEXT buttons during this period will result in changing the screen to one of the 14 available information screens described in S.4-4 below. This action will not influence the warming-up process, so you may pass through all information screens, for instance to monitor the High Voltage value or the Exhaust Air temperature. You can also return to the old one to see how many seconds are still needed for the tube's heater.

NOTE

When you intend to have a short operating break, it is better to leave the amplifier in standby mode instead of turning it off. Tube life is shortened by repeatedly turning on and off the tube heater supply. However, if you unintentionally power-off the amplifier, it is best to switch it on again immediately. When the pause is short (up to 1 minute) and the cathode is still warm, the warm-up period is shortened significantly, which reduces the waiting time and prolongs the tube's expected life.

After the indicated period expires, the ON/OFF button stops flashing and lights green constantly. If the auto-operate function is selected to ON (see S.5-2), the green OPER LED lights too. The last used (one out of 14) information screen appears on the LCD, for instance: "WARMING UP: Ready".

The bargraph on the upper line always indicates the peak forward power (as well as during OFF LINE).

In order to turn the amplifier off press shortly the red ON/OFF button. If you are not going to use the amplifier for a long time, it is best to turn it off using the Main Power switch (on the rear panel) as well.

4-2. Changing Operate and Standby Modes

With the Auto-Operate function disabled (see S.5-2), the OPER button changes two modes alternatively.

When Auto-Operate is ON, the amplifier will be maintained to operate mode by default, unless you use the OPER button manually to go to standby (then Auto-Operate is suppressed temporarily). Pressing OPER again would restore the Auto-Operate.

4-3. Tuning

Tuning is possible only in operate mode, so press the OPER button in order to illuminate its LED (unless Auto-Operate is active).

a) Preliminary information.

Tuning the amplifier is a procedure of matching the impedance of the currently used antenna to the optimum tube load resistance. This will ensure maximum plate efficiency and RF gain at nominal output power, with minimum IMD at that.

Please note, that the REFLECTED POWER readings and the measured VSWR depend on the load impedance only, and not on the amplifier tuning. If the load impedance is different from 50-Ohm pure resistive (nominal), the REFLECTED POWER reading will always indicate reflected power presence (even at excellent tuning). The proper tuning will allow you to operate at greater power without distortion or danger to the amplifier.

Note also that the real OUTPUT POWER in the load is equal to the difference between the FORWARD- and REFLECTED- readings. For instance, at a reading of FORWARD 1200W, and of REFLECTED 200W, the real OUTPUT POWER is 1000W (into a 2.6:1 VSWR load). At very high VSWR (no antenna or badly mismatched antenna), the FORWARD and REFLECTED readings will be almost equal, while the real OUTPUT POWER (the difference between them) will be practically zero.

The amplifier can operate safely if the following rule is obeyed: "REFLECTED POWER < 500W". Matching is assured for loads with VSWR up to 3:1. Nevertheless, for some loads and bands matching is possible at even higher VSWR. For instance, you'll get a

** REFLECTED POWER ** soft-fault protection trip at full-scale (1200W) forward, with more than 500W reflected (700W output power), when antenna VSWR exceeds 4.5:1.

CAUTION

Using a feeder of coaxial cable at VSWR > 3:1 on HF, and particularly on the 10 and 6 meters bands, is not recommended. At such high values of VSWR, the high voltages, high currents, and heat associated with line losses, risk to permanently damage your coaxial cable or antenna switch.

Update tuning periodically, even if you have not changed band or antenna, in particular when a significant change in the environment occurs (snow, ice, newly appeared or removed massive objects, alien wires nearby etc.) that would cause significant changes in the antenna impedance.

NOTE

If you use more than one antenna per band, it is necessary that you select the proper antenna BEFORE the next step. Retune after selecting a different antenna for the same band, since both impedances may differ substantially (unless their VSWR is excellent, i.e. below 1.2:1 for both).

CAUTION

Do not switch the BAND switch knob while transmitting with the amplifier! Hot switching (while transmitting) will eventually destroy the band switch, not covered by the warranty!

CAUTION

When tuning, do not apply continuous drive longer than 3 minutes and after that pause 1-2 minutes for tube cooling.

We recommend that you tune-up at the center frequencies of the preferred frequency band. First select the band switch (never with RF applied!). Then use table 4-1 in order to achieve an approximate preset for both TUNE capacitor and LOAD capacitor knobs:

Band, MHz	Tune Knob Dial	Load Knob Dial
1.8 - 2	75 - 50	75 - 45
3.5 - 4	50 - 30	77 - 60
7 - 7.3	43 - 40	73 - 66
10.1 - 10.2	12 - 10	32 - 30
14 - 14.35	55 - 45	26 - 24
18 - 18.2	61 - 63	54 - 52
21 - 21.45	44 - 17	35 - 33
24.9 - 25	79 - 81	47 - 49
28 - 29.7	46 - 20	36 - 32
50 - 54	40 - 15	16 - 12

Table 4-1. Approximate tuning preset

b) Selecting the plate-load True Resistance Indicator (TRI) tuning aid.

You may select TRI scale in three different ways:

- By pressing simultaneously for a moment the PREV+NEXT buttons. This will insert a 6dB attenuator between the driver and the amplifier's input (the ATT LED will light), so you'll not need to reduce the drive power during tuning. Press PREV+NEXT buttons momentarily again to switch the attenuator off the input and to return to the old screen. If you use any of PREV or NEXT buttons only, the attenuator would be switched off too, but the information screen would change to respectively previous or next.
- By pressing repeatedly either PREV or NEXT button (whichever is nearest), until you reach the TRI scale. This will not insert the attenuator, so you'll have to use less than 20W drive (unless the amplifier is nearly correctly tuned), otherwise the next step would be executed automatically:
- By simply applying a normal working (50-60W) drive power, while the amplifier is not yet tuned.

This will automatically invoke the TRI tuning aid and will insert the input attenuator (the ATT LED will light) after one second. The attenuator will be switched off, and the old screen will be returned automatically, after you release the PTT shortly. If you have achieved meanwhile a nearly good tuning, the attenuator would not be inserted again. If the old screen was the same (TRI, selected manually earlier), you'll then be able to precisely tune the amplifier also at nominal power, without changing drive at all. Use this hint to shorten the tuning process duration.

c) Tuning Procedure.

While a continuous (CW) signal at the desired frequency is still applied:

- Look at the upper scale (forward power); obtain maximum power using the upper (TUNE) knob;
- Look at the lower (Load Cap) scale and turn the lower (LOAD) knob in order to center the triangle marker at the "!" mark.
- Release the PTT shortly in order to disable the attenuator, then repeat both steps at nominal power. Always finish by peaking with the TUNE knob.

NOTE

Appearance of an arrow on either left or right TRI scale edges means that the LOAD knob is too far from the proper position. To correct for this, turn the LOAD knob to the prompted direction until the triangle marker appears inside the scale field.

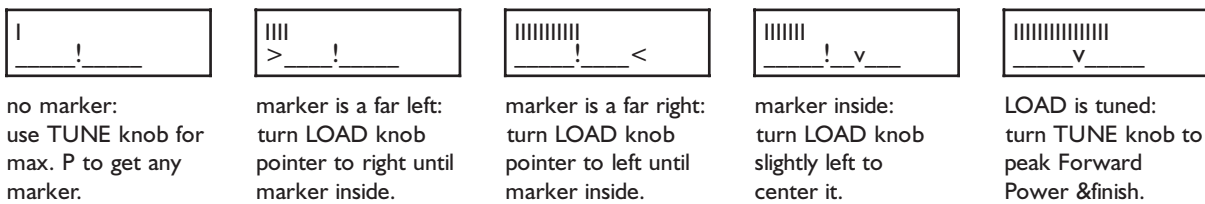

Fig. 4-1. Using TRI tuning aid

Please note also, that the TRI mark will not appear until at least 5W drive is applied, and at least 20W forward power is achieved.

If, for some reason, matching cannot be accomplished successfully, check BAND switch and antenna selection. Then check the antenna VSWR at same drive frequency.

d) Tuning hints.

While turning knobs, you'll note that both tunings would be virtually independent. This is a benefit of the TRI. The plate-load resistance increases to the right and decreases to the left of the TRI center.

The center of the scale corresponds to the proper LOAD capacitor tuning, which presents an optimum load resistance to the tube.

If you tune to the right, you'll obtain more gain, but less undistorted output power will be attainable. You may prefer to use this hint when your drive power is insufficient or when you need less output but better efficiency, for instance at heavy duty modes (RTTY, SSTV etc) where less heat is wanted.

Tuning to the left of the center would lead to the opposite: less gain and more power attainable. Of course, this requires more drive power, more plate current, and more plate heat, which shortens tube's-expected life, as its cathode would be faster exhausted.

You might use the off-center tuning hint also to compensate for mains voltage variations in order to maintain tube efficiency: tune to the right when mains is higher, or tune to the left if it's lower than the nominal voltage. Please see S.2-2 (Line Voltage Selection) for more than 10% difference from the nominal.

4-4. ON LINE Information Screens and Control Functions.

a) Besides the Warming Up and TRI (described above in S.4-1 through S.4-3), you have 12 more Information screens available. They are as follows: Forward Power, Reflected Power, Output Power (difference between forward and reflected), Antenna VSWR, Drive RF Power, RF Power Gain, Plate Current, High Voltage, Plate RF Peak, Screen Current, DC Power Input (product of plate current and high voltage), and Exhaust Air Temperature (Celsius and Fahrenheit scales). You can use them to monitor the technical state of the amplifier and the associated parameters in digital form.

Selection is made by the PREV and NEXT buttons. You may change them in a closed loop, while the amplifier is used and controlled in operate and standby modes, changes transmit and receive, without any influence by the measuring process.

b) You can control LCD adjustment and Auto-Operate feature selection also while ON LINE. The method is the same as it is described for OFF LINE, so see S.5-1 and S.5-2 for details.

4-5. Auto-Protection System

When any abnormal condition is detected, the amplifier will evaluate the risk and may use three different degrees of protection, depending on the nature of the problem. Each event is accompanied by a text telling you the reason. The backlight of the LCD is flashed meanwhile in order to attract the operator's attention.

a) The first degree of protection is issuing a warning message only, without any influence on the transmitting process. This might be for instance "Reduce Drive", "Plate Current", etc. You could continue to transmit under such conditions but you are close to a trip threshold.

b) The second degree of protection is a trip in standby mode (Soft Fault). You'll get an appropriate message, for instance **** GRID CURRENT ****. All Soft-Fault messages are marked with two asterisks on both screen edges. The message remains on the display until you press any button (or auto-operate function returns to operate mode automatically). The Soft Faults are of such kind where you can correct exploitation conditions operatively (using less drive, improving VSWR, etc).

c) The third degree of protection is a trip in off mode (Auto-Protection).

You'll get the corresponding signature (see S.6-5 - Troubleshooting). If you cannot guess what is the reason, you may try to turn the amplifier on again in order to check whether it's not an accidental condition. If the problem persists, you'll need to contact your dealer - see S.1-2.

NOTE

The 6dB input attenuator is automatically inserted about 1 second after a bad tuning is detected at drive levels above 20W. It is switched off at every PTT release (unless inserted manually).

5. OFF LINE OPERATION

There are two control functions and 14 information screens available in this state of the amplifier. You can control the LCD contrast and backlighting or enable/disable the Auto-Operate feature. You can also list the auto - protection signatures. The tube is not powered at all (only the micro-controller is active) during these operations.

5-1. Contrast and Backlighting control

Press the PREV+NEXT buttons simultaneously and hold them for two seconds. The back-lighting of the LCD will light and the “Contrast=... B.Light=...” screen will appear on the bottom line. Control the contrast of the LCD using the PREV button in steps from 1 to 9. Control the backlighting of the LCD using the NEXT button in steps from 1 to 5.

Press shortly the PREV+NEXT buttons in order to reach the auto-operate function (see next S.5-2), or leave buttons unused for 20 seconds if you want to accept these selections only (in order not to change Auto-Operate inadvertently).

5-2. Auto-Operate enabling and disabling

When enabled, this function will save manual actions and operating time for you. It will automatically execute OPERATE commands every time when needed. The OPER button will be still functional, so you'll be able to change to standby and back to operate manually at any time. After returning to operate the first time (by pressing OPER button again), the auto-operate feature will be restored.

In order to enable or disable the auto-operate at all, after a contrast and backlight selection (see the previous S.5-1), continue with pressing shortly the PREV+NEXT buttons. The “Auto Operate = ...” screen will appear on the bottom line. Use the PREV button to select OFF or NEXT to select ON. Press shortly the PREV+NEXT buttons again to accept and return.

NOTE

If LCD back-lighting or contrast are too low, thus no characters are seen on the LCD, execute S.5-1 first to obtain a readable display. All selections you make are stored in the nonvolatile memory of the amplifier and are used at the next power-on. If no selection is made for 20 seconds, the currently existing selection is accepted and the function is left automatically.

5-3. Reading Auto-protection Signatures

On every Hard Fault protection trip of the amplifier, signature information is stored in its nonvolatile memory. The 7 most recent auto-protection trip signatures related to the amplifier internal status are stored there, which you can copy and forward to your dealer for diagnostics.

In order to read and to copy them press the OPER button while OFF LINE. The backlighting of the LCD will light and you'll see the beginning of the signatures list. Use NEXT and PREV buttons to navigate through 7 pairs of screens. For each auto-protection trip there is a pair of information screens, beginning with nA... and nB... where:

- “n” is the number of the event (nr.1 is the last, nr.7 is the oldest one);
- A and B mark the first and the second part of an information screen pair.

Two lines, three groups by six symbols (36 symbols in total) are to be copied concerning every one of the 7 memorized events from 1A-1B through 7A-7B.

To decode the signatures please see S.6-5 (Troubleshooting).

NOTE

After every signature listing the tube warm-up time is reset to 150 seconds regardless of the time being in OFF LINE state.

6. MAINTENANCE

If no characters are seen on the LCD at power on maybe its contrast needs adjustment - see S.5-1.

6-1. Cleaning

WARNING

Do not use solvents for cleaning - they may be dangerous both for you and for the amplifier paint or plastics.

Do not open the amplifier. Cleaning of the amplifier outer surface can be done with a piece of soft cotton cloth lightly moistened with clean water.

6-2. Fuses Replacement

If it is necessary to replace the mains fuses, use only standard ones.

The two Primary Mains Fuses of the amplifier are located on the rear panel (Fig. 2-1). They are 10A/250V Quick blow, 1-1/4 x 1/4 inch Cartridge Fuses, Size "0" Ceramic.

Besides the primary fuses, on the MAINS PCB (inside the amplifier) there are two more small glass fuses (5x20mm, 100mA and 2A slow-blow type) which are not replaced by the user. Should one of these fuses be blown, it may be indicative of other failures. This is a complex and potentially dangerous operation. For this reason, we recommend this work be carried out by a trained service technician.

6-3. Tube Replacement

A single 4CX800A (GU74B) high-performance ceramic-metal tetrode manufactured by Svetlana is employed in the amplifier. Replacement is a complex and potentially dangerous operation. For this reason, we recommend this work be carried out by a trained service technician.

6-4. The ACOM1000 Simplified Schematic Diagram

See Fig.6-1 ACOM1000 Simplified Schematic Diagram. * The 4CX800A (GU74B) Svetlana high performance ceramic-metal tetrode (VI) with plate dissipation of 800W is grid-driven. The input signal from the RF INPUT jack is passed through a broadband input matching circuit, which comprises some components in the INPUT PCB and Rsw. This circuit tunes out the input capacitance of the tube. The swamping resistor Rsw is a termination load for this circuit and can dissipate up to 100W of RF drive power.

Cathode resistor R_c creates DC and RF negative feedback, thus stabilizing the gain and equalizing the frequency response. The varistor V_{Ssg} in the screen grid circuit protects the tube screen grid, and voltage regulator in the events of a flashover.

The combination L_{p1} - R_{p1} in the plate circuit is a VHF/UHF parasitic suppressor. DC plate voltage is fed through chokes RFC1-RFC2 and the capacitor C_{b3} blocks it from the output. The output circuit comprises LP1, LP2, LL, CP1-CP3, and CL1-CL3 which form a classic Pi-L network and suppress the harmonic frequency emissions. This tank is switched and tuned over the bands by S1A-S1C and the air variable capacitors CP1, 2 and CL1, 2. The output signal is fed through an additional VHF low-pass filter for frequencies above 55MHz (L_{f1} , L_{f2} and C_f). Then it is passed through the vacuum antenna relay K1, wattmeter current transformer TA1, and a high-pass filter RFC4- C_a for frequencies below 100kHz, to the antenna output. The chokes RFC3 and RFC4 keep track of the antenna relay contact conditions and together with C_a prevent the plate supply from reaching the antenna. RFC4 shunts it to ground if the DC blocking capacitor C_{b3} fails. The resistor R_a protects the amplifier from charging Electro-static energy fed by the antenna.

The PLATE CAPACITIVE DIVIDER and RF WATTMETER are the main sources of information for the control circuit of the amplifier during the antenna impedance matching process. The control circuit is based on the 80C552 micro-controller from Philips.

All voltages are delivered from the MAINS&LOW VOLTAGE and HIGH VOLTAGE SUPPLY PCBs. The control grid, screen grid and plate currents, plate cooling airflow temperature, reflected power etc. are permanently monitored. Many software-derived protections are based on this information.

* Detailed electrical schematic diagrams are available from ACOM or from your dealer on request.

6-5. Troubleshooting

See S.5-3 for the method of reading the auto-protection signatures. You can decode them using the information below. *

The signatures are structured in two lines, three groups by six symbols for every one event of auto-protection. The last event is numbered as 1A-1B pair of lines, and the oldest one is 7A-7B.

The meaning of the first group is as follows:

a) nA - the number of the trip;

b) Next three symbols mean the following:

PN0 - tests made during Power-On procedure, before HV is ON;

PN2 - tests made during Power-On procedure, after HV is ON and 1 second after step-start is closed;

SB0 - tests made in Stand-By, during the warm-up period or while entering Stand By (from Operate);

SB2 - tests made during Stand-By, after the warm-up period;

PR0 - tests made while entering Operate;

PR2 - tests made during Operate;

TR0 - antenna relay tests made while changing from Tx to Rx (during Operate)

TR2 - antenna relay tests made while changing from Rx to Tx (during Operate)

TR4 - antenna relay tests made during Tx (Operate mode)

TR6 - antenna relay tests made during Rx (Operate mode)

c) The last symbol of the first group designates the kind of the input parameter, which caused the protection to trip. The abbreviations in brackets below are the signal names/designations according to the CONTROL PCB electrical schematic diagram and signal type:

1 - peak forward power (pfwd, analogue)

2 - reflected power (rfl, analogue)

3 - input (drive) power (inp, analogue)

4 - peak anode alternate voltage (paav, analogue)

5 - screen grid current (g2c, analogue)

6 - plate current (ipm, analogue)

7 - high voltage (hvm, analogue)

8 - exhaust air temperature (temp, analogue)

9 - drive power exists (*GRIDRF, logic)

A - antenna power exists (*PANT, logic)

B - output relay closed (ORC, logic)

C - arc fault (ARCF, logic)

D - control grid current too high (GIC, logic)

E - +24VDC power supply error (PSE, logic)

F - low airflow (LAIR, logic)

For instance, "IATR4B" in the first group would mean that the last auto-protection (IA) tripped by the antenna relay tests made during Tx - Operate mode (TR4), and the "output relay closed - ORC" signal was failing (B).

The next five groups of symbols carry information about the analogue and logic values as measured by the micro-controller (at the moment of auto-protection trip).

* Additional information is available from ACOM or from your dealer on how to interpret these values. Using an EXCEL APPLICATION (available from ACOM or your dealer free of charge) and a PC, you can decode these signatures easily by yourself.

In case it is necessary to ship the amplifier please see S.7-3.

7. SPECIFICATIONS

7-1. Parameters

a) Frequency Coverage: All amateur bands 1.8-54MHz, extensions and/or changes on request.

b) Power Output: 1000W PEP or continuous carrier, no mode limit.

In continuous carrier modes (RTTY etc.) for transmissions longer than 15 minutes (up to several hours depending on ambient temperature), the external auxiliary fan must be mounted.

c) Intermodulation Distortion: Better than 35dB below rated output.

d) Hum and noise: Better than 40dB below rated output.

e) Harmonic Output Suppression:

1.8-29.7MHz - better than 50dB below rated output,

50-54MHz - better than 66dB below rated output.

f) Input and Output Impedances:

- Nominal value: 50 Ohm unbalanced, UHF (SO239) type connectors;

- Input circuit: broadband, VSWR less than 1.3:1, 1.8-54MHz continuously (no tunings, no switching);

- Bypass path VSWR less than 1.1:1, 1.8-54MHz continuously;

- Output (antenna) impedance matching capability: VSWR up to 3:1 or higher.

g) RF Gain: 12.5dB typically, frequency response less than 1dB (50 to 60W drive power for rated output).

h) Primary Power: 170-264V (200, 210, 220, 230 & 240V nominal taps (100, 110 & 120V taps on request), +10% -15% tol.), 50-60Hz, single phase, 2200VA consumption at rated output.

i) Complies with CE safety and electromagnetic compatibility requirements as well as FCC-regulations (10 & 12m bands lock provided).

l) Size & Weight (operating): W422mm x D355mm x H182mm, 22kg.

m) Operating environments:

- Temperature range: 0...+50 degs. Celsius;

- Humidity: up to 75% @ +35 degs. Celsius.

- Height: up to 3000m above sea level without output deterioration.

7-2. Functions

- a) Antenna Impedance Matching Process: plate-load True Resistance Indicator (TRI) aided.
- b) T/R System: QSK operation with built-in, vacuum RF antenna relay (special quiet installation).
- c) Protections:
 - Cover interlock for operator's safety;
 - Inrush power-on current control;
 - High voltage, control grid, screen grid, and plate currents;
 - Exhaust air temperature;
 - T/R sequencing;
 - Antenna relay contacts, including RF power induced in antenna from another nearby transmitter;
 - Antenna matching quality;
 - Reflected power;
 - RF arcs, including in antenna system;
 - Overdrive.
- d) Signatures of the amplifier internal status are stored in a nonvolatile memory for the seven most recent auto protection trips.
- e) Dot matrix backlit alphanumeric LCD with bargraph for forward peak power and text messages to the operator.
- f) Measurement and constantly monitoring of 12 most important parameters of the amplifier via LCD.
- g) Menu-selectable LCD Backlight and Contrast.
- h) Tube: a single 4CX800A (GU74B) high-performance ceramic-metal tetrode of Svetlana with plate dissipation of 800W, grid driven, forced air-cooling.

7-3. Storage and Shipment

CAUTION

Should you need to transport the amplifier, use the original packing as described below.

First, switch off the amplifier. Pull the mains plug out of the outlet. Disconnect all cables from the rear panel of the amplifier (remove the ground connection the last). Finally, pack the amplifier in its original carton.

- a) Storage environments: the amplifier can be kept packed in dry and ventilated unheated premises without chemically active substances (acids, alkalis etc.) in the following climatic environment:

- Temperature range: -40 to +70 degs. Celsius;

- Humidity: up to 75% @ +35 degs. Celsius.

b) Shipping Size and Weight:

W590mm x D430mm x H305mm, 25kg.

c) Shipping environments: all types of transportation, including aircraft baggage section up to 12000 meters above sea level.