

FIGURE 1

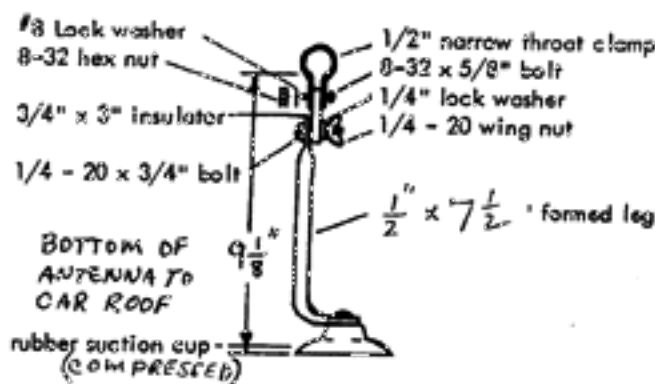

FIGURE 2

PARTS LIST

5/8" x 2 7/8" tubing section with insulator	1
5/8" x 2 7/8" tubing section with Reddi Match	1
1/2" x 2 7/8" formed tubing sections	2
3/4" x 3 1" mast mounting boom	1
1/2" x 7 1/2" formed tubing legs	4
Rubber suction cups with 1/4" bolts	4

PARTS PACKAGE

3/4" x 3" flat insulators	4
1/2" wide throat telescope clamps	4
5/8" narrow throat telescope clamps	4
7/8" formed aluminum bracket	1
2-1/2" formed aluminum bracket	1
3" aluminum u-bolt backing plate	1
3/4" x 1/4 - 20 steel round head bolts	4
1/4 - 20 wing nuts	4
1/4" lock washers	4
8-32 x 5/8" stainless steel bolts	8
8-32 hex stainless steel nuts	8
#8 internal lock washers	8
2-1/4" x 10 - 24 round head bolts	1
#10 internal lock washers	1
10 - 24 hex nuts	1

ASSEMBLY FOR CAR TOP MOUNTING

- Assemble the Squalo support legs and suction cups as shown in figure 2. Slide the support legs on to the 1/2" x 2 7/8" tubing, approximately 1" from the bend.
- Assemble the 5/8" narrow throat clamps using a 5/8" stainless steel bolt, #8 internal lockwasher, and 8-32 hex nut. Slide the clamps over the ends of the 5/8" tubing sections. Slide the 1/2" formed tubing into the 5/8" sections, to form the square, and tighten the tubing clamps finger tight. The approximate setting is 1/2 - 1/4" from the end of the 5/8" tubing to the inside of the 1/2" tubing, dimension A, figure 1.
- Center the Squalo on your car roof, with the Reddi Match and insulator sections parallel to the sides of the car. Clean the mounting surface thoroughly. Moisten the area under the cups and press them down firmly. If the area under the cups is not clean, they will not hold the vacuum. When properly mounted, the Squalo will stay in position at normal highway driving speeds. The support legs can be adjusted to fit any contour by loosening the tubing clamps and/or the wing nuts. When the Squalo is correctly positioned and level, tighten all support leg fasteners.
- Attach a 52ohm line (RG-58/U) coax feed line to the Reddi Match terminals as shown in figure 1. Run the coax down through the mounting block center hole, and out to the car roof edge. Because of the relatively small diameter of RG-58/U coax, it can generally be run into the car through the door or trunk edge without damage to the car or cable. The Squalo must be tuned by following the procedure outlined on the next page.

You will find that you have extra parts after the antenna is assembled. They are used for mast mounting the Squalo.

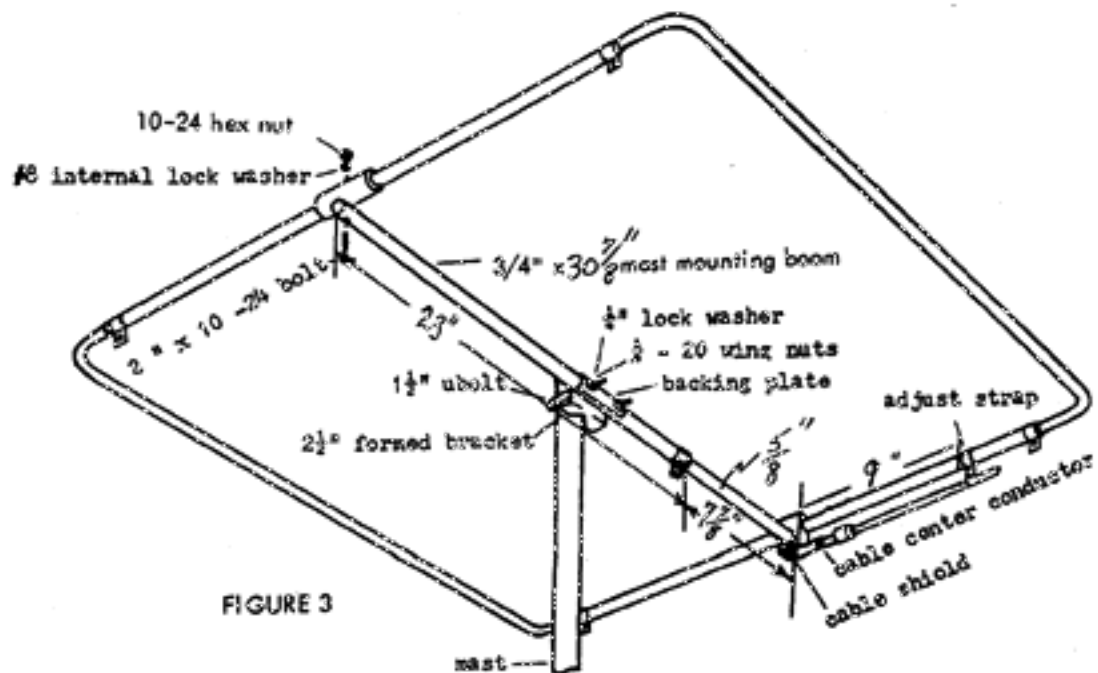

FIGURE 3

ASSEMBLY FOR MAST OR TOWER MOUNTING:

- (1) Assemble the Squalo by following step #2 of the car top mounting instructions. The approximate setting, dimension A, is figure 3. For mast mounting, the machined aluminum block should be vertical, with the Reddi Match below the 5/8" tubing, figure 3.
- (2) Insert one end of the 3/4" x 30 7/8" mast mounting support into the machined block and tighten the set screw. attach the free end of the mast mount support to the insulator, figure 3.
- (3) Mount the Squalo on your mast. Attach the feed line to the Reddi Match. Run the coax along the mast mounting boom, and down the mast, figure 3.

TUNING INSTRUCTIONS

When tuning the Squalo, you must use a reliable SWR bridge in conjunction with your transceiver.

CAR TOP

- (1) Insert the standing wave ratio bridge in your 52 ohm feed line between the transmitter and the Squalo.
- (2) a. Depress your microphone switch and check the SWR reading. b. Loosen one of the 5/8" telescope clamps and move the 1/2" tubing slightly in either direction, figure 1. c. Move away from the antenna, depress the switch, and check the SWR reading. d. If the adjustment has lowered the SWR, repeat steps a, b, & c, making slight adjustments until a minimum SWR is indicated. If the SWR has risen, your adjustments must be made by sliding the 1/2" tubing in the opposite direction.
- (3) After attaining a minimum SWR by adjusting the 1/2" tubing, tighten the 5/8" telescope clamp. If no reflected power (SWR) is indicated on the bridge, no further adjustments are necessary. If reflected power is indicated, it can be tuned out by adjusting the Reddi Match as outlined below.
- (4) Loosen the tuning strap, figure 1, and move it slightly in either direction. Move away from the antenna, push the microphone switch, and check the SWR reading. If the SWR has risen, adjust the strap slightly in the opposite direction. If the adjustment has lowered the SWR, repeat the procedure making only slight adjustments until no reflected power (1 to 1 SWR) is indicated on the bridge. Tighten Reddi Match strap.
- (5) When properly tuned, the Squalo should cover

MAST OR TOWER MOUNTING:

To tune Squalo for mast or tower mounting, follow steps 1, 2, 3, and 4, above.

When the antenna is completely assembled and tuned, tighten all fasteners. Feed line connections should be taped and covered with a protective coating of Krylon spray or equal.

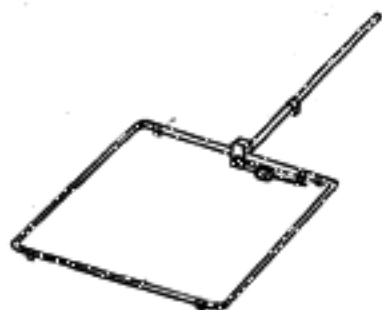

FIGURE 4

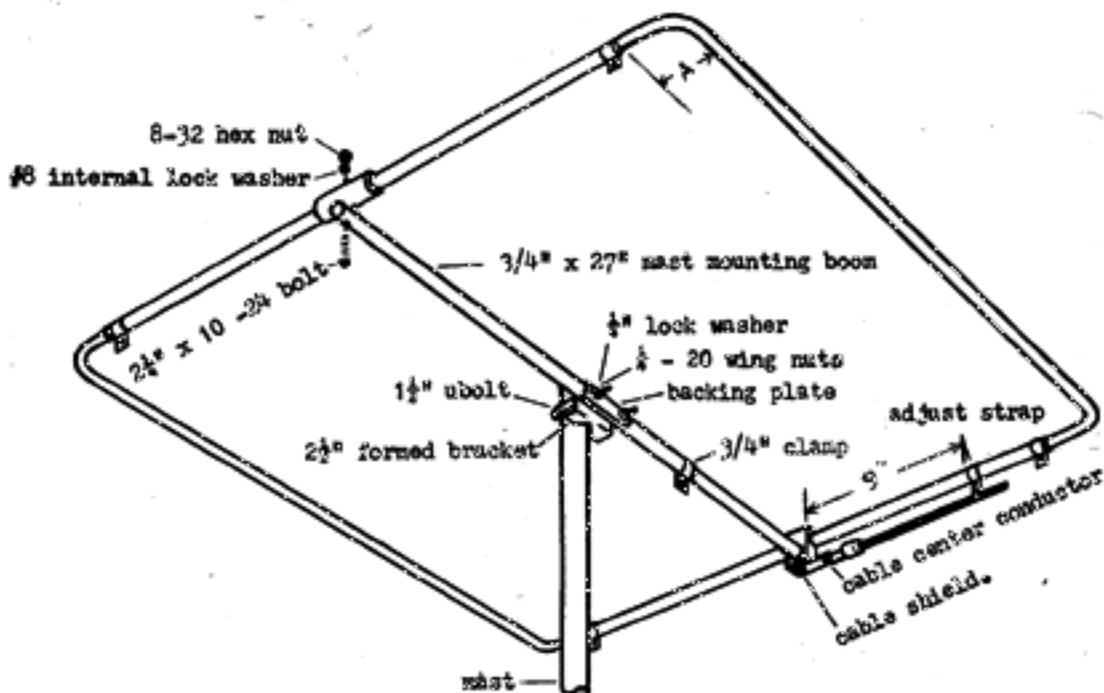

FIGURE 3

ASSEMBLY FOR MAST, TOWER, OR TEMPORARY MOUNTING:

- (1) Assemble the Squalo by following step # 2 of the car top mounting instructions. The approximate setting, dimension A is $1 \frac{3}{8}$ " figure 3. For mast mounting the machined aluminum block should be vertical, with the Reddi Match below the $\frac{5}{8}$ " tubing, figure 3.
- (2) Insert the capped end of the $\frac{5}{8}$ " x 9" tubing into the machined block and tighten the set screw. Slide the slotted end of the $\frac{3}{4}$ " x 27" mast mounting boom over the $\frac{5}{8}$ " tubing. Attach the free end to the insulator, and tighten the $\frac{3}{4}$ " clamp, figure 3.
- (3) Mount the Squalo on your mast. Attach the feed line to the Reddi Match. Run the coax along the mast mounting boom, and down the mast, figure 3.
- (4) For temporary mounting i.e. out a window follow the assembly procedure in step 1 above. Assemble the two sections of the mast mounting boom, and insert the $\frac{5}{8}$ " tubing into the machined block, figure 4.

The rubber suction cups, clamps, and insulators: they are used only on the car top mounted Squalo, and are not required on the mast mounted antenna.

TUNING INSTRUCTIONS:

When tuning the Squalo you must use a reliable SWR bridge in conjunction with your transmitter, or the transmitter section of your transceiver.

- (1) Insert the standing wave ratio bridge in the feed line between the transmitter and the Squalo, and set the transmitter to operating frequency.
- (2) Adjust the bridge for maximum forward power reading from the transmitter. With the bridge in the reverse position - (SWR) move the $\frac{1}{2}$ " tubing, on one corner of the Squalo, slightly in either direction. A $\frac{1}{8}$ " movement should be sufficient if the antenna has been set up to the dimensions given in figures 1 and 3. Move away from the antenna when checking the reading. It may be necessary to make several slight adjustments to reach the lowest SWR reading. If the amount of adjustment on one corner exceeds $\frac{1}{4}$ " then all corners should be reset approximately $\frac{1}{8}$ ", and the adjustment procedure repeated on one corner.
- (3) Adjust the Reddi Match strap slightly in either direction to the minimum SWR reading.

When the antenna is completely assembled and tuned tighten all fasteners. Feed line connections should be taped and covered with a protective coating of Krylon spray or equal.