

# INSTALLATION INSTRUCTIONS

## CHANNEL GUARD High-Frequency Crystal IF Filters

These crystal filters for 7.8 MHz and 10.695 MHz CB receiver IF circuits are designed to reduce bleedover interference. They work by narrowing the “skirt” selectivity around the center of the radio’s IF passband. Our filter uses two very high-Q quartz crystals and a compensating amplifier to achieve this result.

All CBs have tuned transformers between the IF amplifier stages to help produce the receiver’s overall selectivity. However the “Q” (the Selectivity Factor) of such transformers isn’t nearly as high as that of a crystal. The graph shows this difference. Both curves at the insertion point are about 8 KHz wide. But the typical IF transformer is much more broadbanded. Even at  $\pm 8$  KHz away from center, the attenuation is still minimum, about -18 dB. Strong adjacent channel signals can easily cause bleedover interference to the desired signal. Compare this broad curve to that of the crystal filter. The skirts are very narrow, and at  $\pm 8$  KHz, the attenuation can be -60 dB or better. The result is a dramatic drop in adjacent-channel interference.

### FILTER PLACEMENT

The exact placement of any filter in the receiver IF chain is very important, and can make a difference in receiver performance. There are two schools of thought about its location in the circuit path:

1. Placing the filter very early in the IF strip, such as immediately following the first mixer, will help establish the overall receiver selectivity. Many CB rigs only use a single conversion process for both SSB and AM. Or they convert down a second time for AM and FM later in the circuit. So placing the filter early in the IF strip means that it will work in all modes.
2. Noise is normally generated within the IF amplifiers themselves. If the filter is placed further down the IF strip toward the Detector end, such noise can be reduced. This results in improved sensitivity as well as selectivity. Noise is broadbanded in nature and the less noise that gets through to the Detector, the better the Signal-to-Noise Ratio of the receiver.

A few of the better base rigs already use two IF filters. All AM/SSB rigs use a multipole crystal filter, which is switched to operate on both RX and TX. This filter is the large metal can about 2" x 1" that you see on the main chassis. For RX, it provides basic IF selectivity. For the SSB TX mode, it filters out one of the two sidebands. The second filter (if present) is a simple monolithic device which looks like a regular crystal, with three wires instead of two. “Monolithic” means that it has two quartz elements that share the same physical ground, in a single crystal holder. It’s a cheap way of using two “crystals” in one can, instead of two individual crystals (which are sharper) like our filters use.

In most installations the best placement is early on, immediately following the First Mixer stage. The extra selectivity will reduce extremely strong signals which might otherwise desensitize the receiver IF strip.

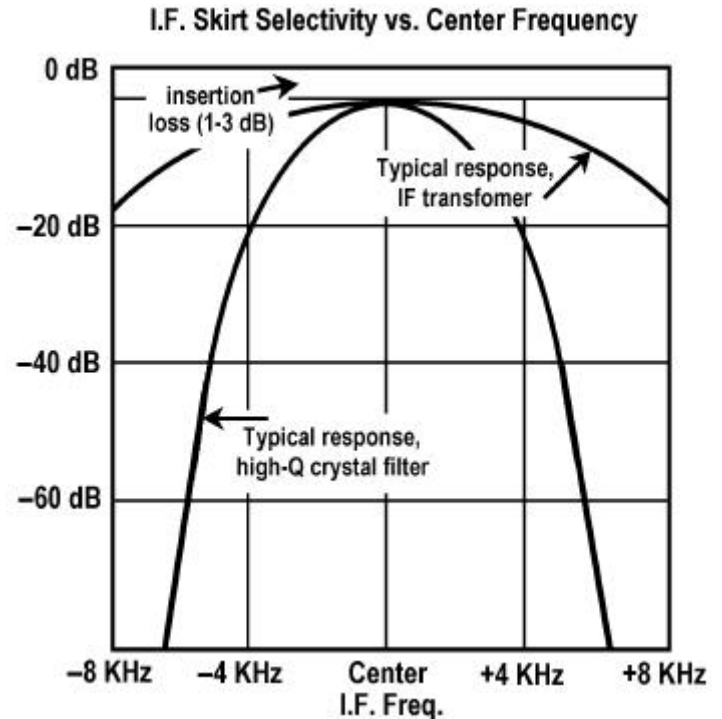

Manufactured by:

CBC INTERNATIONAL · P.O. BOX 30655 · TUCSON AZ 85751 U.S.A.  
TEL & FAX: 1-888-I-FIX-CBs (1-888-434-9227) · Local: (520) 298-7980  
Internet: [www.cbcintl.com](http://www.cbcintl.com) · Email: [info@cbcintl.com](mailto:info@cbcintl.com)

## INSTALLATION & APPLICATION NOTES

For proper performance, the filter must be correctly installed in the radio's IF strip. This normally involves nothing more than removing an interstage coupling capacitor and installing the *CHANNEL GUARD*'s INPUT and OUTPUT wires into the correct empty capacitor holes. Then the middle bare wire is grounded, and the 12" stranded wire is run to the +DC voltage source. The last two pages show the specific capacitor to remove for all the most popular CB chassis types, along with the correct INPUT and OUTPUT holes.

1

### TYPICAL BANDPASS FILTER

Many rigs use 2 or 3 stage transformer coupling. Each connects with a small (2-5pF) capacitor. Remove this and install CG filter here.

OR

2

### TYPICAL IF AMP STAGE

Each IF stage that uses a transistor amplifier is usually coupled by a capacitor. Remove this and install CG filter here.

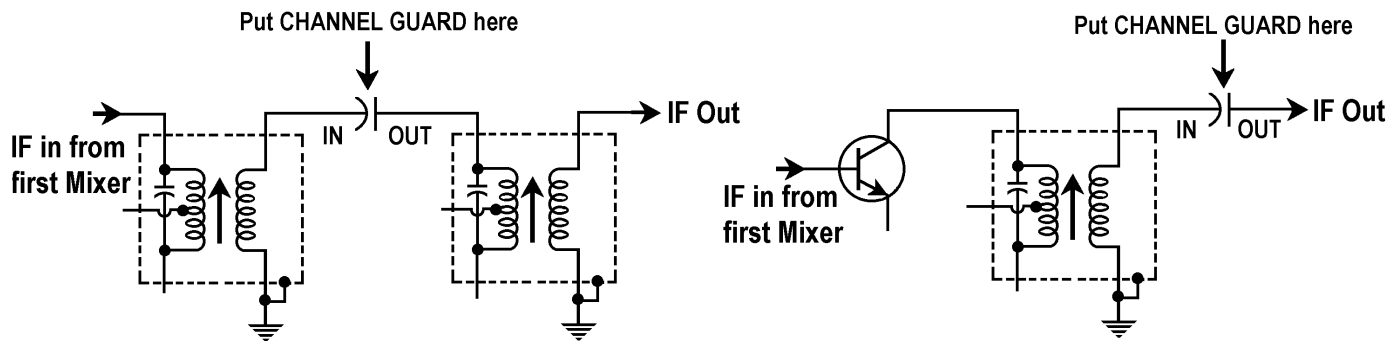

### SPECIAL NOTE: AM-only Models

Many older AM CBs used an 11.275 MHz IF. The *CHANNEL GUARD* won't work with these models. You can order an 11.275 MHz crystal (specify "series" or 10 pF Load Capacitance) to really sharpen up the bleedover rejection. Install it in place of the correct IF coupling capacitor. If you try this, remember to solder a third ground wire to the crystal, then ground it to the radio chassis. We still have a small supply of 11.275 MHz crystals available at \$12 postpaid; contact us for details. A few old AM and AM/SSB rigs used a 9.785 MHz IF; we don't have these crystals, but you could order one and use the same trick there.

### INSTALLATION INSTRUCTIONS

Shown above schematically is the general installation point between IF stages. The sketch at the right shows the filter connections. With the parts side up and the colored wire on your right, the three bare wires are (left to right): INPUT, GROUND, OUTPUT. Place the INPUT and OUTPUT wires into the two holes vacated by the coupling capacitor you removed. Solder the center GROUND wire to any convenient ground point. You can often tack it to the nearest metal IF can. Connect the 12" stranded wire to a convenient source of DC operating voltage, usually +8-13.8 VDC. An easy connection for this is directly at the switch lugs of the ON/OFF/VOLUME control. Connect to the lug on the *switched* side, not the input side. This way, no power is applied unless the radio is turned on.

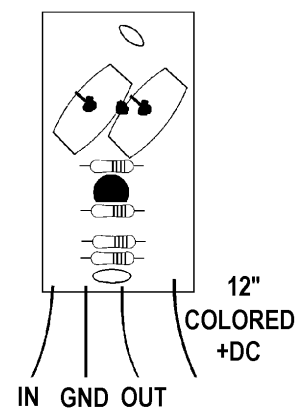

### NOTES:

1. We've included a piece of black plastic sleeving to slip over the bare INPUT and OUTPUT wires. The CG will often need to fit in a very tight space on the chassis, so always use this insulation to avoid shorts.
2. Reversing the IN and OUT bare wires is the most common mistake people make. This is usually obvious because the RX sensitivity as indicated by your S-Meter or speaker volume will drop way down. And make *sure* you removed the right coupling capacitor!

## GENERAL TECH NOTES & INSTALLATION TIPS

1. Always ground the center filter wire to the chassis ground or common point. Any of the metal IF transformer cans will take solder, and these make a good hookup point. This ground connection also provides the –DC return path to power the filter; the filter’s amp won’t be powered up without it. And grounding helps remove stray signals that cause oscillations or other interference to proper filter operation.
2. The following radios use non-standard IFs, for which we have no crystal filters: Browning Mark III, Mark IV/IVA, Tram D201/D201A. However the second IF is 455 KHz and our 455 filter works well here.
3. The following radios cannot use the high-frequency filter: Sears 934.3826/3831, 3827, and equivalent in J.C. Penney chassis such as 981- 6241,6246, 6248. These use an 11.275 MHz IF which is not capacitively coupled. The filter can’t be installed in the signal path without breaking the DC supply to the mixer or IF transistor. The 455 KHz filter can be used, but for AM only.
4. Many radios that are AM-only can use the 10.695 MHz as well as the 455 KHz filter. The crystal filter is much sharper than the ceramic 455 types. Almost all 40-channel PLL AMs use a 10.695 MHz first IF. The older 23-channel AMs with the 23/14 MHz master synthesizers have an 11.275 MHz IF. There’s no *CHANNEL GUARD*, but our special 11.275 MHz crystal (\$12 postpaid) can still be added to improve IF selectivity. (Limited quantity of these; send stamped SAE if interested.)
5. The *CHANNEL GUARD* should not increase the IF gain. It’s designed for a zero-loss, zero-gain effect. Excess gain shows up as: higher than normal S-Meter reading, background noise, buzzing, squealing, or audio distortion. In such cases, you can try lowering the amp gain a bit. Increase the value of the emitter resistor slightly. This is the resistor immediately below the transistor, a 560? (green-blue-brown) value. Try a 680K? or even 1K? to rebias the amplifier. If this doesn’t work, you have some other problem.
6. Be sure the filter is installed only in the *Receive* signal path, never in the Transmit path. Correct points are already shown for the models on our list. For other radios, the SSB TX signal passes through the radio IF filter, typically by use of switching diodes. If you install the *CHANNEL GUARD* in this path, you may slice off part of the transmitted sideband, resulting in distorted audio or off-frequency operation.
7. Recheck the alignment of the IF transformers just before and after the filter installation point. Consult your schematic or SAMS Fotofacts®. Make sure these coils are still peaked for maximum signal strength, as indicated on the rig’s S-Meter. Filter installation sometimes has an effect on the alignment of these IF cans.
8. Avoid shorts! Black plastic sleeving is provided to slip over the #22 bare filter wires. You may also need to put some electrical tape on the solder side of the filter PC board, if the filter has any possibility of touching other nearby metal parts.
9. Sometimes it’s not possible to stand the filter up vertically from the radio’s PC board. In such installations, bend the filter leads at right angles and don’t cut them off. For extra physical support, solder another bare wire between one of the crystals and a nearby transformer coil. This forms a bridge, with the filter supported at each of its long ends.
10. Never install the filter within the Noise Blanker signal path. Any sharp filtering there can stretch out the noise pulses, making the blanker useless. This is a common problem in all the Uniden and Uniden-clone SSB IF circuits, *unless you follow our specific hookup locations*. These radios all use a bandpass filter of two or three capacitively coupled coils following the first Mixer stage. The NB signal input sample usually connects to one of these coils, and the NB output kill-switch to the coil immediately following it down the IF path. Unfortunately in many of these circuits the only non-NB filter location works only for SSB; these are noted where present. Use the radio’s schematic if you have any doubts.
11. Glorified CB type "Ham" rigs (Uniden HR2510, Galaxy 2517, RCI-2950, RCI-6900, etc.) use the standard Uniden dual-conversion IF circuit. **Our 10.695 MHz filter works wonders in these models!** We've included instructions for many of these on Pp. 4-5. On the negative side, many of these newer RCI, Ranger, and Galaxy models now use Surface-Mount (chip) parts, often including the main PCB that has the IF capacitor you need to remove in order to install our filter. The incredibly small foil spacing means you must use EXTREME CAUTION and possibly even drill tiny holes into the main PCB when trying to install the filter into this area. Such installations are recommended for pros only!

## 10.695 MHz AM/SSB APPLICATIONS LIST

**NOTE:** Either the 10.695 MHz or 455 KHz CG can be installed in most AM- only or FM-only radios. If interested, send SASE for details.

### **Cybernet PLL02A American & Canadian, PTBM048AOX or PTDM058COX**

AWA/Thorn 1503, Boman CB950, Cardon Iroquois 40, Colt 480, 485DX, 890, 1000, 1200 (Excalibur), Gemtronics GTX77, G.E. 3-5825A, HyGain 2705 (V), 3108 (VIII), J.C. Penney 981-6247, JIL Citizen MPL-5, SSB-M6, Lafayette Telsat SSB80, SSB120, SSB140, Midland 78-976, Palomar 2900, Pearce- Simpson Super Panther, RCA 14T302, Truetone CYJ4837A-87, Universe 5600:

A wire marked "C" runs from the secondary terminal of T10 *not* going to C111/R88, to a foil pad containing one end of C122 and D12, near T13. Cut this wire and install the CG in series. (IN = T10 end, OUT = C122/D12 end.)

**Dak Mark X only:** Cut gray shielded cable connecting T10/C121 to CFI/D12. Install CG in series. (IN = T10/C121, OUT = CFI/D12)

### **Cybernet PLL02A American, PTBM080/085COX & PTRF004/005DOX**

G.E. 3-5875A Superbase, Midland 78-574, 78-999, SBE LCBS-4: Remove C279 on RF board. (IN = Q210/T207, OUT = T208.)

### **Cybernet PLL02A Export, PTBM059COX & PTOS006 or PTSY016AOX**

Ham Int'l Concorde, Jumbo, Multimode II, HyGain V, Lafayette 1200FM, Major M360, M588: A wire marked "C" runs from the secondary terminal of T10 *not* going to C111/R88, to a foil pad containing one end of C122 and D12 on the main PTBM059 board, near T13. Cut this wire and install the CG in series. (IN = T10 end, OUT = C122/D12 end.)

### **Cybernet PLL02A Export, PTBM121D4X, PTBM121COX**

Cobra GTL150, Colt 320DX, 320FM, 1200DX (Excalibur), Ham Int'l Concorde II, HyGain 2795DX, Intek 1200FM, Lafayette HB70AFS, Tristar 747: A wire marked "I" runs from one secondary terminal of T12 (the terminal *not* going to C116/R90) to the pad marked "I" next to T13 (that contains one end of C120/D14). Remove wire from "I". (IN = wire from T12, OUT = "I". (C120/D14 junction next to T13.)

### **Cybernet PLL02A Export, PTBM125A4X or PTBM131A4X**

Colt 1600DX, 2000DX, HyGain 8795 (V), Lafayette 1800, Midland 7001 export, Pacific 160, Superstar 2000, Tristar 777:

Remove C120. (IN = T11/Q19, OUT = T12.)

**Cybernet PLL02A Export, PTBM133A4X:** Ham Int'l Concorde III, Jumbo III, Multimode III. Remove C117. (IN = T11/R96, OUT = T12.)

### **Cybernet PLL02A Export, PCMA001S**

Argus 5000, Colt 2400, Cobra 148GTL-DX (fake), Falcon 2000, Lafayette 2400FM, Mongoose 2000, Nato 2000, Palomar 2400, 5000, Starfire DX, Superstar 2200, Thunder 2000, Tristar 797, Tristar 848: Remove C120. (IN = T11/Q19, OUT = T12.)

### **Early Uniden $\mu$ PD2824 PLL SSB Chassis (10.695 MHz IF, PC833, PC965)**

Cobra 146GTL, Midland 6001/7001 late, 79-260, Pearce-Simpson Super Cheetah, President P300, AR144, AX144, Realistic TRC451, Sears 663.3810, Uniden PC244: Remove C46. (IN = L6, OUT = L7/C47.)

### **Late Uniden $\mu$ PD2824 SSB Chassis (PB062, PB105, PB122)**

Realistic TRC453, TRC465, TRC850, Uniden PC122, PC122XL, PRO-640e, PRO-810e: Remove C40. (IN = L8, OUT = R58/D12.)

### **Uniden Multimode Export w/MC145106 PLL, PB010 chassis**

Cobra 148GTL-DX late, Superstar 360FM:

Remove C61. (IN = L11, OUT = L12/C62.)

### **Uniden Multimode Export w/MC145106 PLL, PB042 chassis**

President Jackson (also clone Superstar Jackson EPT00JA-10Z):

Remove R74 (470  $\Omega$ ). (IN = FT4/C16/C17, OUT = R75/TRI3.)

### **Uniden Multimode Export w/MC145106 PLL, PC879 chassis**

Cobra 148GTL-DX early: Remove C48. (IN = L6, OUT = L7/C49.)

### **Uniden Multimode Export w/MC145106 PLL, PC893 chassis**

Stalker 9-FDX, President McKinley export:

Remove C57. (IN = L10, OUT = L11/C58.)

### **Uniden Multimode Export w/MC145106 PLL, PC999 chassis**

President Grant Export: Remove C61. (IN = L11, OUT = L12/C62.)

### **Uniden "clone" multimode copycat models using MC145106 PLL and with EPT3600-10A, -10Z, -11A, 11Z, -14B or similar chassis.**

**NOTE: If in doubt about your specific chassis, check the other AM/FM "clone" listings below or send us the exact chassis details.**

Cherokee CBS2100, NR100, NR150, Connex 3300, 3500, Dirland 3000, 3300, 3500, 3600, 3700, 3900, Eagle 2000, Euro 3900, Excalibur (base), Excalibur Samurai, Galaxy 11B, Galaxy 2100, Galaxy II, Galaxy DX33, DX44, DX55, DX66, DX73V, DX77, DX88, DX99, Galaxy Pluto, Galaxy Saturn, Galaxy Sirius, General Lee, Mirage 44, Mirage 6600, Mirage 88, Mirage 9900, Mirage II, Mirage III, Northstar 3000, 4000, 6000, 9000, 9500, President Franklin, Super Galaxy, Superstar Grant, Superstar 3000, 3001, 3300, 3500, 3600, 3900:

Remove C58. (IN = L10, OUT = L11/C59.)

### **Early Uniden "Clone" AM/FM fakes w/MC145106 PLL & EPT3000-10A ECI chassis**

Dirland/Superstar 3000: Remove C53. (IN = L9, OUT = L10/C54.)

### **Early Uniden "Clone" AM/FM fakes w/MC145106 PLL & EPTMARS-10Z ECI chassis**

Dirland/Superstar 3500: Best-remove C38. (IN = L6, OUT = Q8/C39/R22.) Not as effective-replace FL1 (IN = L7, OUT = R26/R27/Q9.)

(10.695 MHz models cont'd on Page 5)

## 10.695 MHz AM/SSB APPLICATIONS LIST, cont'd

### Miscellaneous Newer CB or 10M SSB Chassis

Cobra 148FGTL-DX+, Connex 4400, 4800, Galaxy DX949, DX959, DX2517, General Grant, RCI2960, RCI6300, Texas Ranger 396, 399, 696, 699

with EPT6900 or EPT0696 main PCB: Remove C61. (IN = L8, OUT = L9/C62.)

Cherokee CBS-1000: Remove C32. (IN = L33, OUT = L34.)

Courier Galaxy IV: Remove C30. (IN = T7, OUT = D10/R31.)

Courier Galaxy V, VI: Remove C58. (IN = L10, OUT = L11/C59.)

Eagle 5000, Galaxy DX-2527, 22B, Saturn Turbo, early RCI2950, 2970, 2980, 2990, & "DX" models, Sommerkamp TS-2000DX:

Remove C72. (IN = L12, OUT = L13/C73.)

Emperor TS-5010: Remove C115. (IN = L104, OUT = R304.)

G.E. 3-5826A: Remove C55. (IN = T7, OUT = T9.)

Magnum 257, 357, 457\*: Remove C87. (IN = T8/Q8/R14, OUT = T7)

Magnum Delta Force\*: Remove C187. (IN = L112/C117, OUT = D124/R204/R206.)

\*NOTE: For SSB only; no way to install CG to include AM and FM modes without defeating the Noise Blanker.

Midland 79-265: Remove C30. (IN = T7, OUT = R31/D10.)

Midland 79-290: Remove C57. (IN = T4, OUT = Q19/R69.)

Radio Shack HTX-100: Remove C43. (IN = L5, OUT = R56/D14.)

Radio Shack TRC485: Remove C32. (IN = T4/Q4, OUT = T5.)

Ranger AR3300, AR3500: Remove C24. (IN = R21/C416, OUT = R20/D8.)

RCI2950, 2970, 2990 w/new EPT6950 PCB: WARNING: This has an SMD main chassis; leave this installation to a pro! (Info not yet available.)

RCI6900 w/new EPT9900 PCB: WARNING: This has an SMD main chassis; leave this installation to a pro!

Remove C68. (IN = L8, OUT = L9/C69.)

Uniden HR2510, 2830, President Lincoln: Remove C15. (IN = L115, OUT = D105/R9.) C15 is between L115 and SSB filter FT102.

Bend leads 90° and install on foil side of PCB; criss-cross the IN/OUT leads and use the sleeving insulation provided. Put some insulating tape between filter and radio PCB.

Uniden HR2600: same as HR2510 above, except IN = L4, OUT = R9/D5.

## 7.8 MHz AM/SSB APPLICATIONS LIST

### **μPD858 PLL (early Uniden SSB chassis)**

Courier Gladiator PLL, Spartan PLL, Fanon Fanfare 350F, Midland 79-893: Remove C49. (IN = T5, OUT = R50/D20)

Cobra 138XLR, Palomar SSB500 early, Realistic TRC449, Robyn SB510D, Teaberry Stalker 101, 102:

Remove C20. (IN = L5, OUT = R19/D4/C21.)

**NOTE:** Foreign mobile models like Stag 357 (LC7120 PLL), Palomar SSB500 late (MC145106 PLL), or WKS1001 (MC145106) are otherwise identical to Cobra 138XLR above. Remove C20, same as above.

Cobra 139XLR, President Adams, old Grant, old Madison, old Washington, Realistic TRC457/TRC458, Robyn SB520D, Teaberry Stalker 202:

Replace existing monolithic filter "FT2" for best results. (IN = L5, OUT = L6.)

Courier Centurion PLL, Centurion 40D: Remove C22. (IN = L5, OUT = C23/R19/D5.)

### **MB8719/MB8734 PLL (late Uniden single-conversion SSB chassis)**

Cobra 140GTL, 142GTL, Courier Galaxy, President McKinley, Washington (late), P400, Realistic TRC450/TRC490, Robyn SB505D, SBE LCBS-8, LCMS-8, early Superstar 360, Teaberry Stalker IX, XV, XX, Tram D80/D300, Uniden Washington:

Remove C42. (IN = L7, OUT = L6/C44.)

Midland 79-900: Remove C43. (IN = L8, OUT = L7.)

### **MB8719/MB8734 PLL (late Uniden or Uniden-clone dual-conversion SSB chassis)**

Cobra 148GTL, 148GTL-F, 2000GTL, 2010GTL-WX, Pearce-Simpson Super Bengal Mk II, President Grant (late), Madison (late), Stalker XX export, Uniden Grant, Grant XL, Madison: Remove C47. (IN = L7, OUT = L8.)

### **RCI8719 PLL (Ranger clone of above 148GTL Uniden dual-conversion SSB chassis)**

Texas Ranger 296: Remove C47. (IN = L7, OUT = L8.)

### **μPD2824 PLL SSB chassis (early Uniden 7.8 MHz IF, PC582, PC585, PC621)**

Craig L132, L232, Wards GEN-719A: Remove C45. (IN = L7, OUT = L6/C49.)

### **Early NDC40013 PLL SSB Chassis**

SBE Console V, Sidebander IV, Sidebander V: Remove C118. (IN = C115/Q103, OUT = T104.)

### **Late NDC40013 PLL SSB Chassis**

Craig L131, L231: Remove C212. (IN = T203, OUT = Q204/R208.)

Johnson Viking 4740, Viking 352D: Remove C415. (IN = T404, OUT = Q404/R411.)

Johnson Messenger 4730: Remove C417. (IN = Q404/C415, OUT = L402/CR405.)

Pace 1000BC, 1000MC: Remove C314. (IN = T308, OUT = R343/CR303/R342/C315.)

NDI PC200, PC201, Tram D64: Remove C326. (IN = T305, OUT = Q305/R317.)

SBE Console VI: Remove C118. (IN = Q103, OUT = T105.)

### **Toshiba TC5080/81/82 PLL SSB Chassis**

Browning Baron, Cobra 132/135XLR, Tram D62:

Remove C28. (IN = Q5/R31/R32, OUT = Q6/R33.) **NOTE:** Watch excessive gain here; there are already several preceding IF amp stages.

### **Miscellaneous PLL SSB Chassis**

Realistic TRC448: Cut trace connecting T208 secondary (IN) to base of Q209 (OUT). Place in series.

Realistic TRC459: Remove C75. (IN = T10/C82, OUT = Q21/R83.)

Realistic TRC480: Remove C83. (IN = T10/TP6, OUT = Q22/R84.)

### **Miscellaneous 23-Channel Crystal Synthesizer SSB Chassis**

**NOTE:** In most cases these are *for AM improvement only*, because there's usually no common mode coupling capacitor. Some do have a separate SSB capacitor; send SASE for details if that's what you prefer. These were all dynamite rigs in their day!

Browning LTD, Cobra 132A: Remove C55. (IN = Q9/T10/IC2, OUT = T11.)

Cobra 130: Remove C305. (IN = Q2/T3/C108, OUT = T8.)

Cobra 132/135: Remove C85. (IN = Q11/T10/U4, OUT = T11.)

Cobra 138/139, Midland 13-893, 13-895: Remove C11. (IN = T4, OUT = D2/R9.)

Courier Centurion, Gladiator: Remove C219. (IN = T9/C60, OUT = T12.)

Courier Spartan: Remove C21. (IN = D15/R32/C46, OUT = T5.)

Midland 13-893, 13-895: Remove C11. (IN = T4, OUT = D2/R9.)

Pace Sidetalk 1000B/1000M, Tram XL-5: Remove C313. (IN = R314/CR304/CR305, OUT = FL301.)

Pearce-Simpson Bengal: Remove C10. (IN = D15/R39/C46, OUT = T1.)

Pearce-Simpson Cheetah: Remove C98. (IN = D10/R33/C69, OUT = T11.)

Pearce-Simpson Panther: Remove C21. (IN = D15/R32/C46, OUT = T5.)

Pearce-Simpson Simba: Remove C219. (IN = D11/R29/C65, OUT = T12.)

SBE 12CB (Sidebander II), 16CB (Console II): SSB only—remove C140 (IN = T4, OUT = T6).

AM only—remove C145. (IN = R148/C132/T5, OUT = D20/D21.)

**NOTE:** No combo AM/SSB installation possible in above SBE models without defeating the Noise Blanker!

SBE 18CB (Sidebander III): Remove C120 (IN = D9/R113/D4, OUT = FL1.)

Tram D60: Remove C57. (IN = Q10/T10/IC2, OUT = T11.)

Tram XL-5: Remove C313. (IN = R314/CR304/CR305, OUT = FL301.)

For specific hookup of models not listed here, you can mail us a stamped SASE or send Internet email and the *exact* make/model to:

**CBC INTERNATIONAL · P.O. BOX 30655 · TUCSON AZ 85751 U.S.A.**

**TEL & FAX: 888-1-FIX-CBs (888-434-9227) · Local: (520) 298-7980**

**Internet: [www.cbcintl.com](http://www.cbcintl.com) · Email: [info@cbcintl.com](mailto:info@cbcintl.com)**

