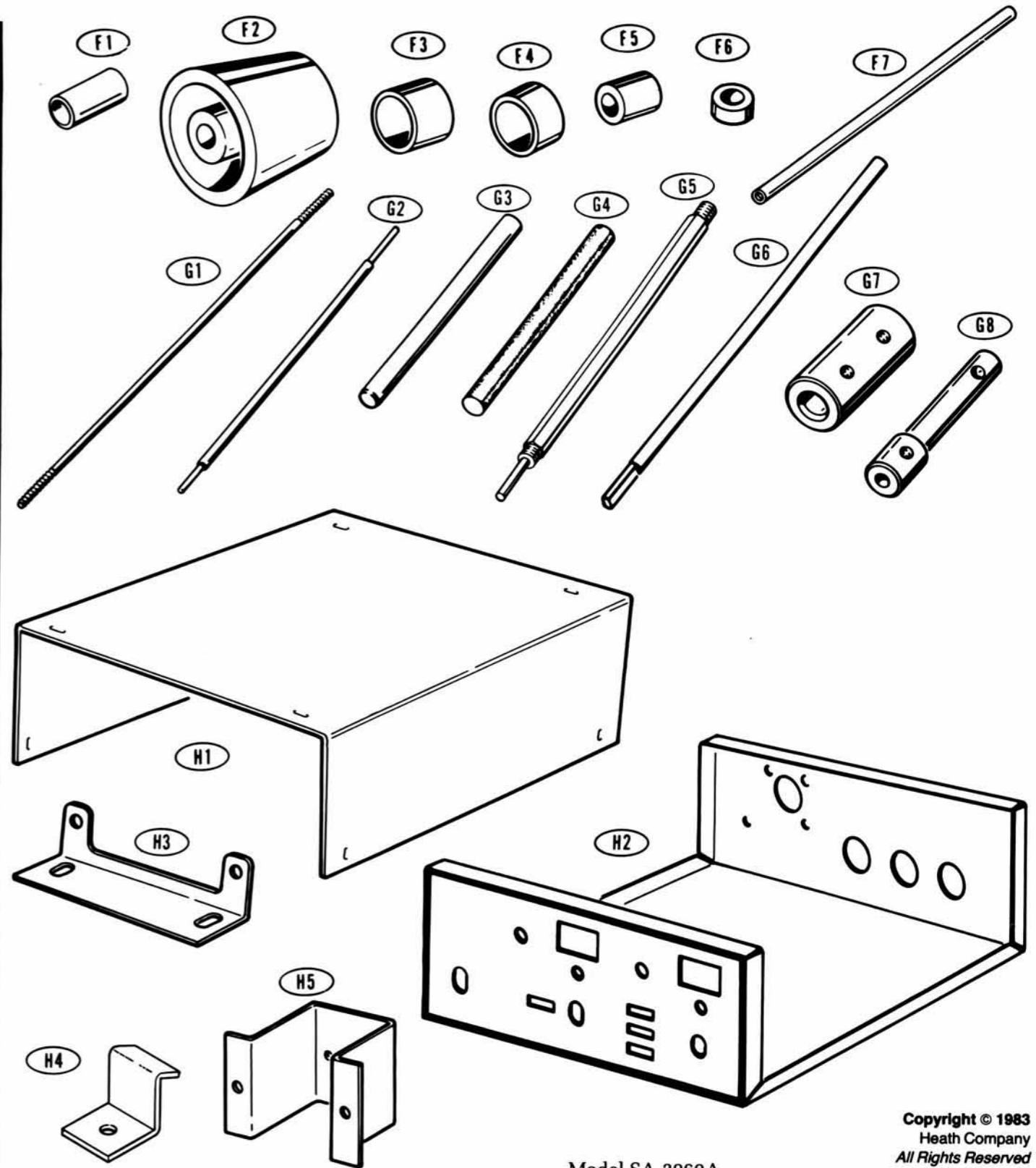
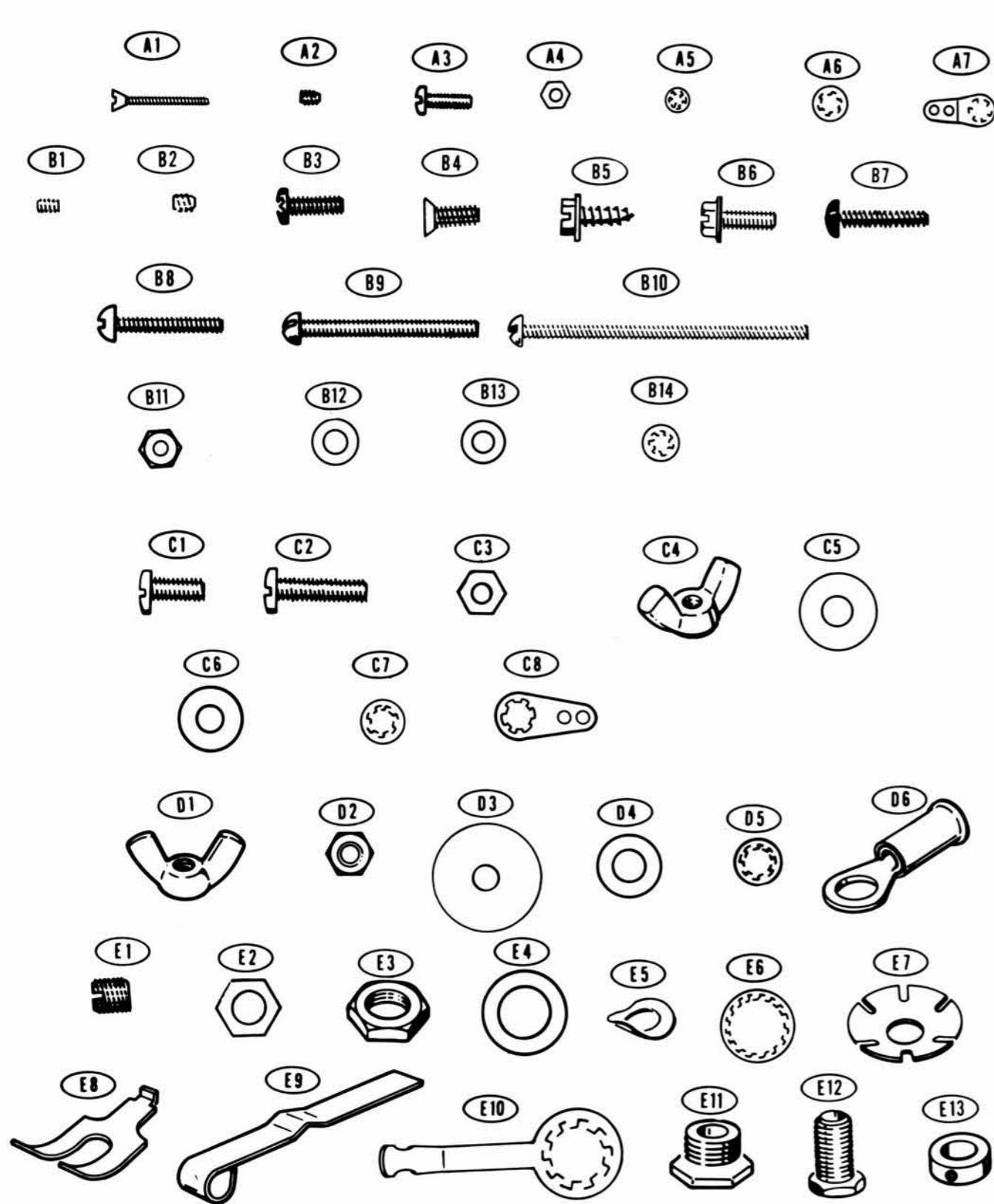

ILLUSTRATION BOOKLET

Part of 595-2971-01

PARTS PICTORIAL



Model SA-2060A

Copyright © 1983
Heath Company
All Rights Reserved
Printed in the United States of America

PARTS PICTORIAL

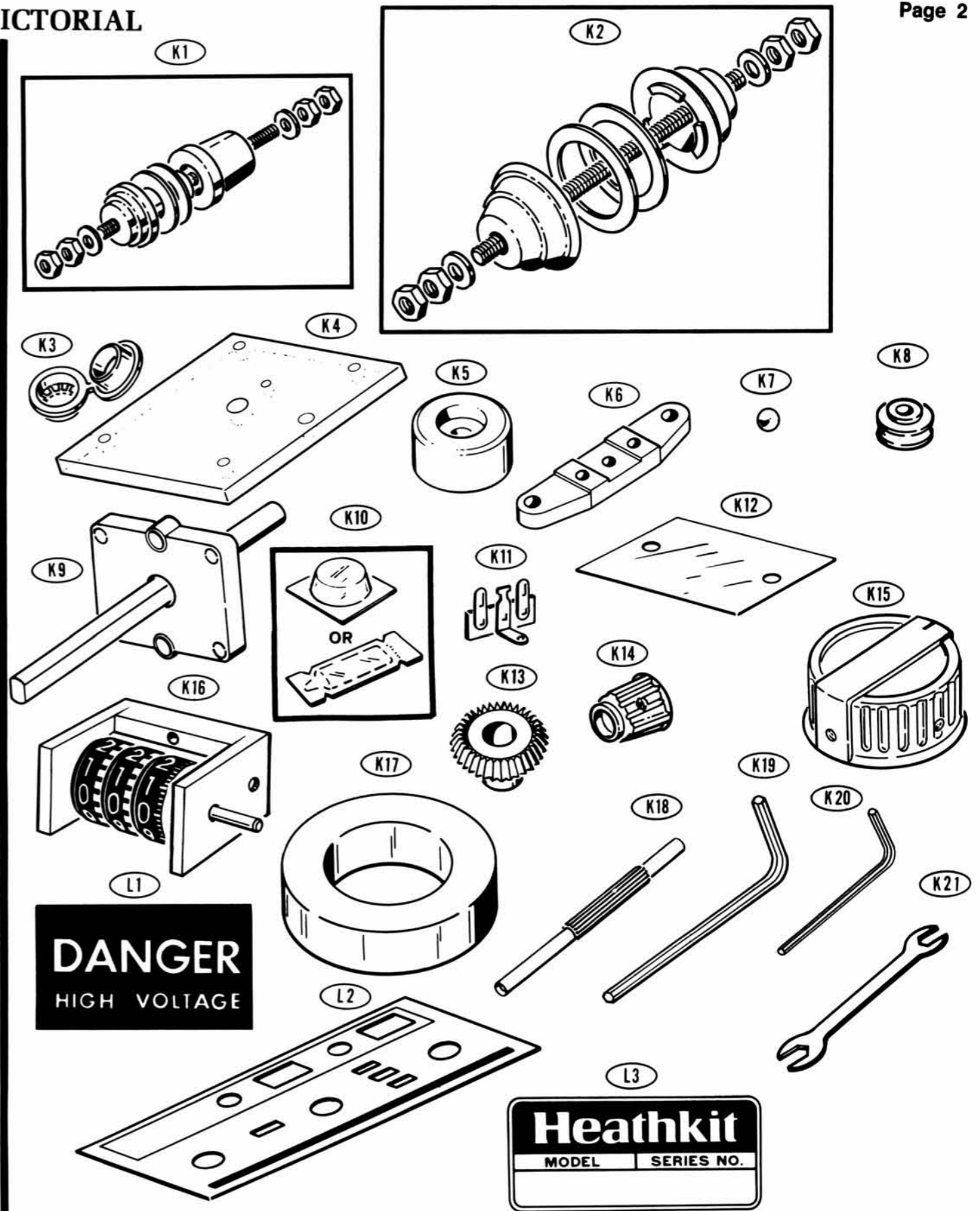
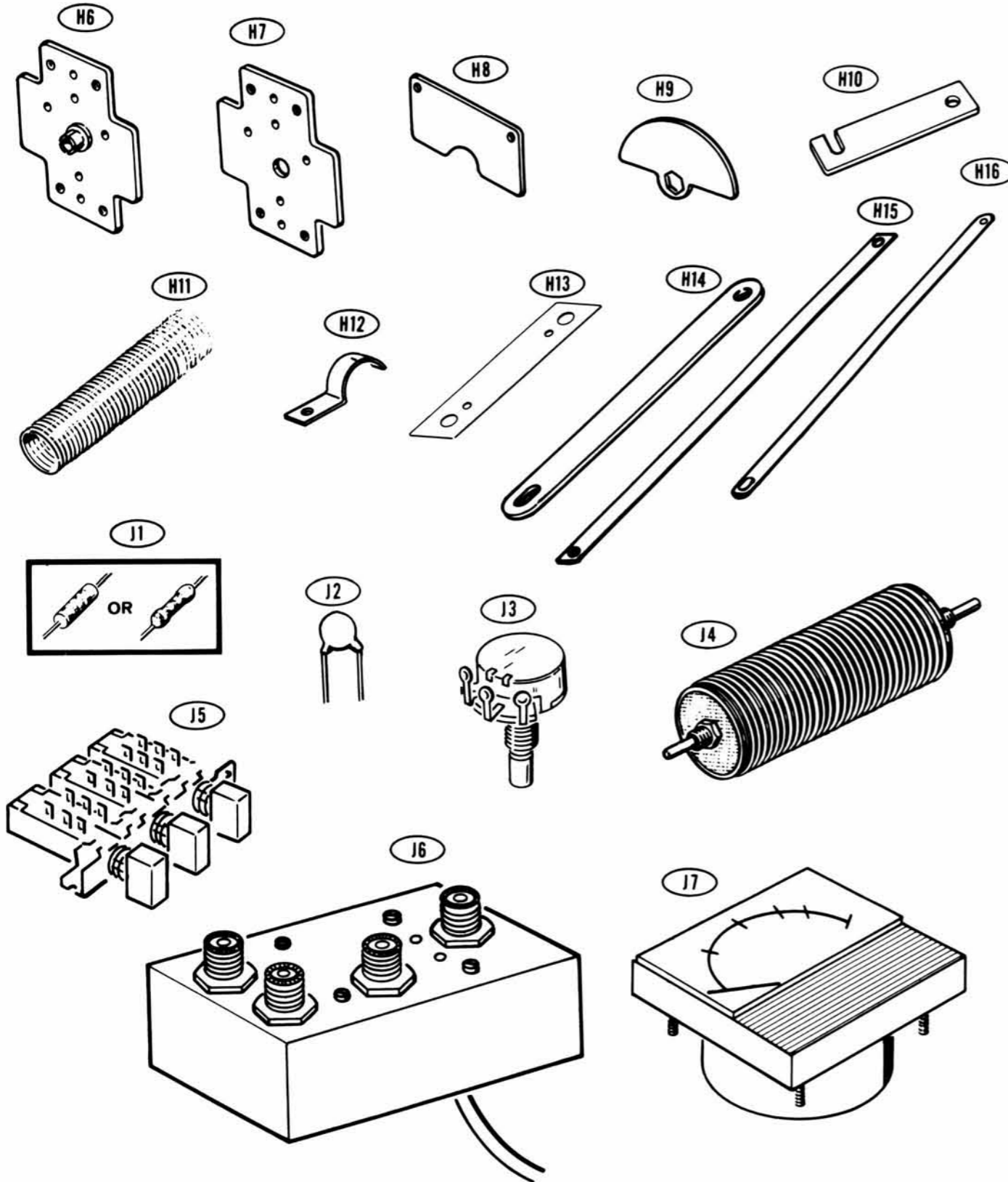

DANGER
HIGH VOLTAGE

Heathkit
MODEL SERIES NO.

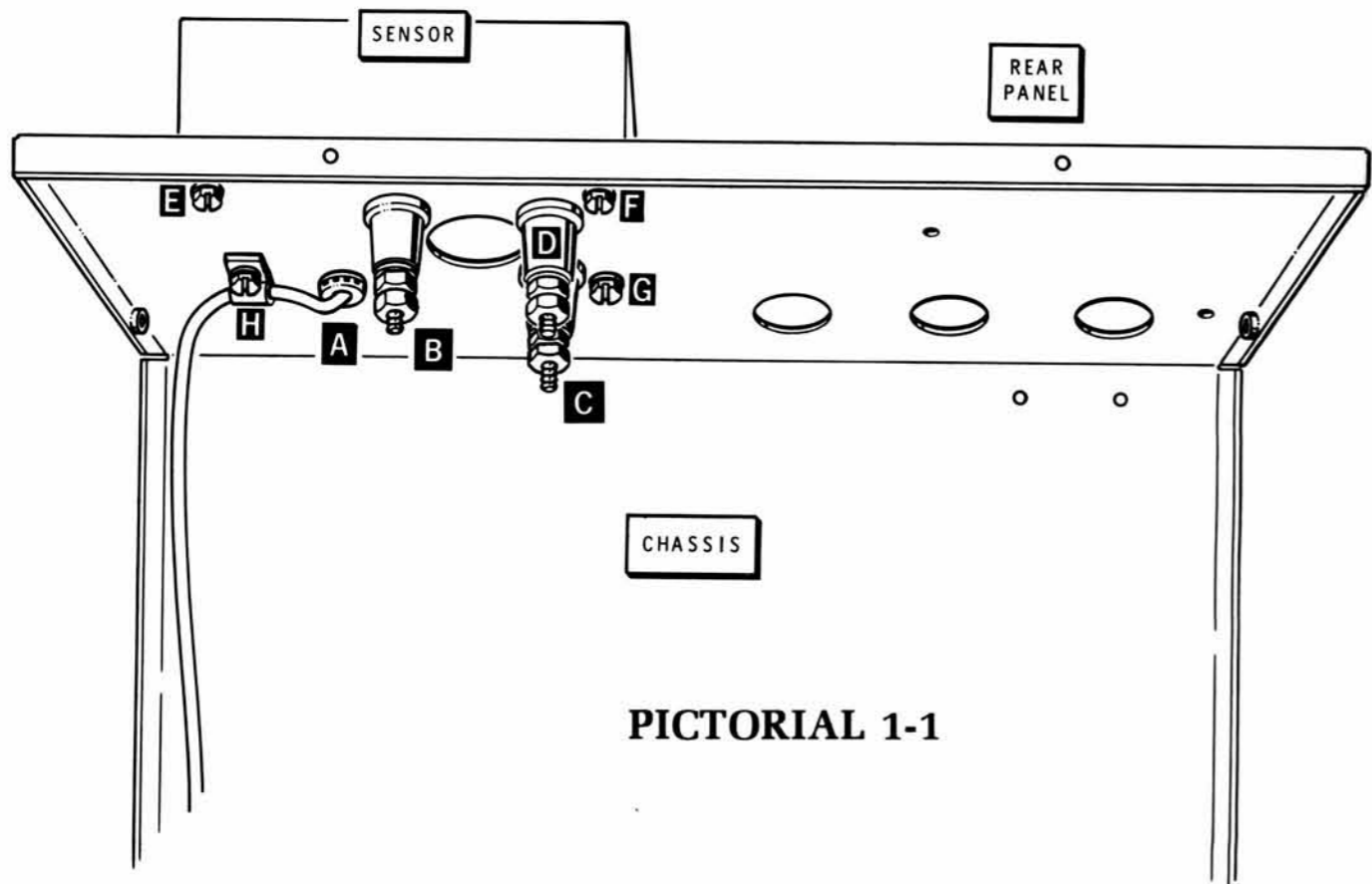

PICTORIAL 1-1

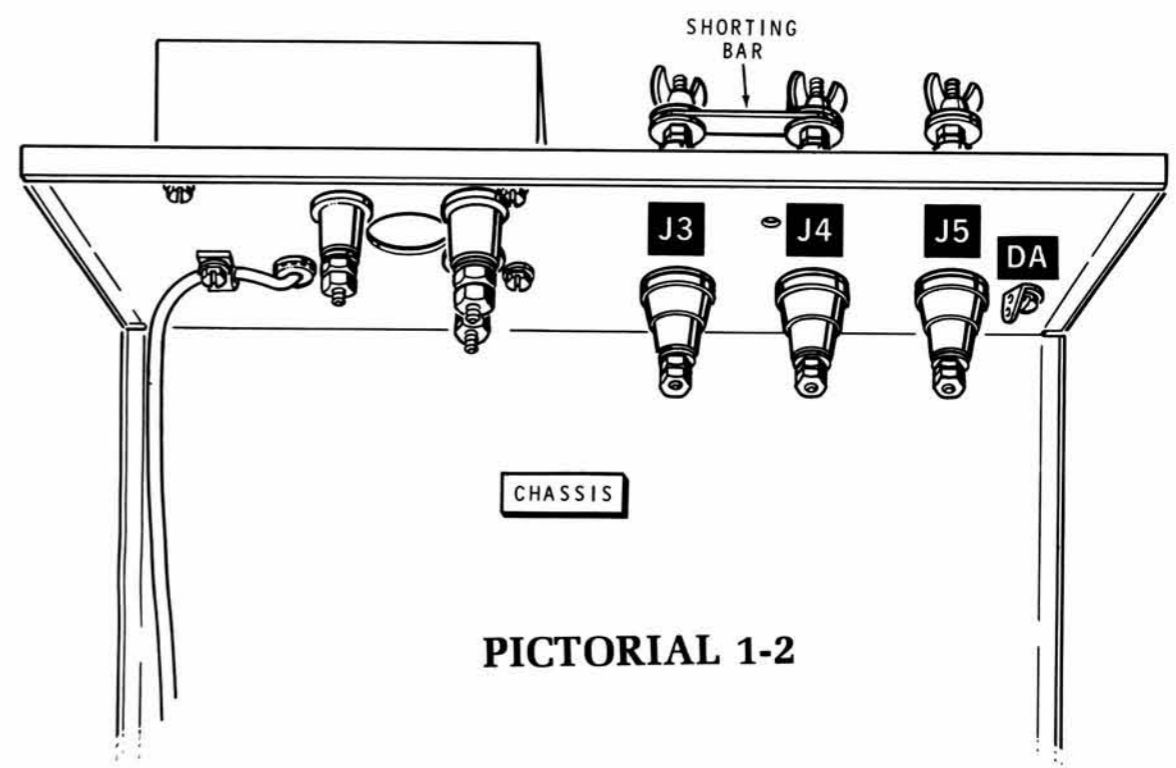

PICTORIAL 1-2

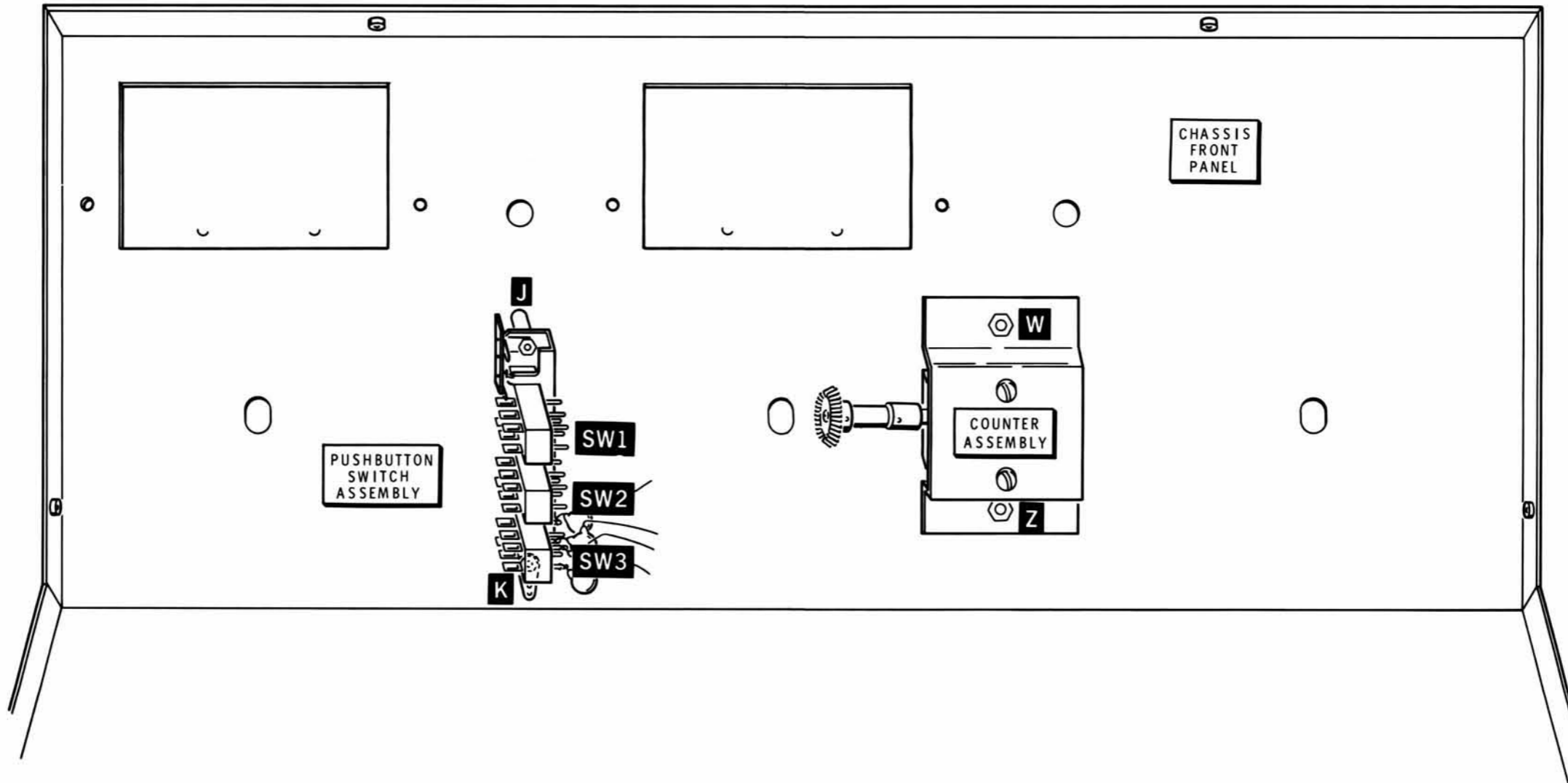

PICTORIAL 2-3

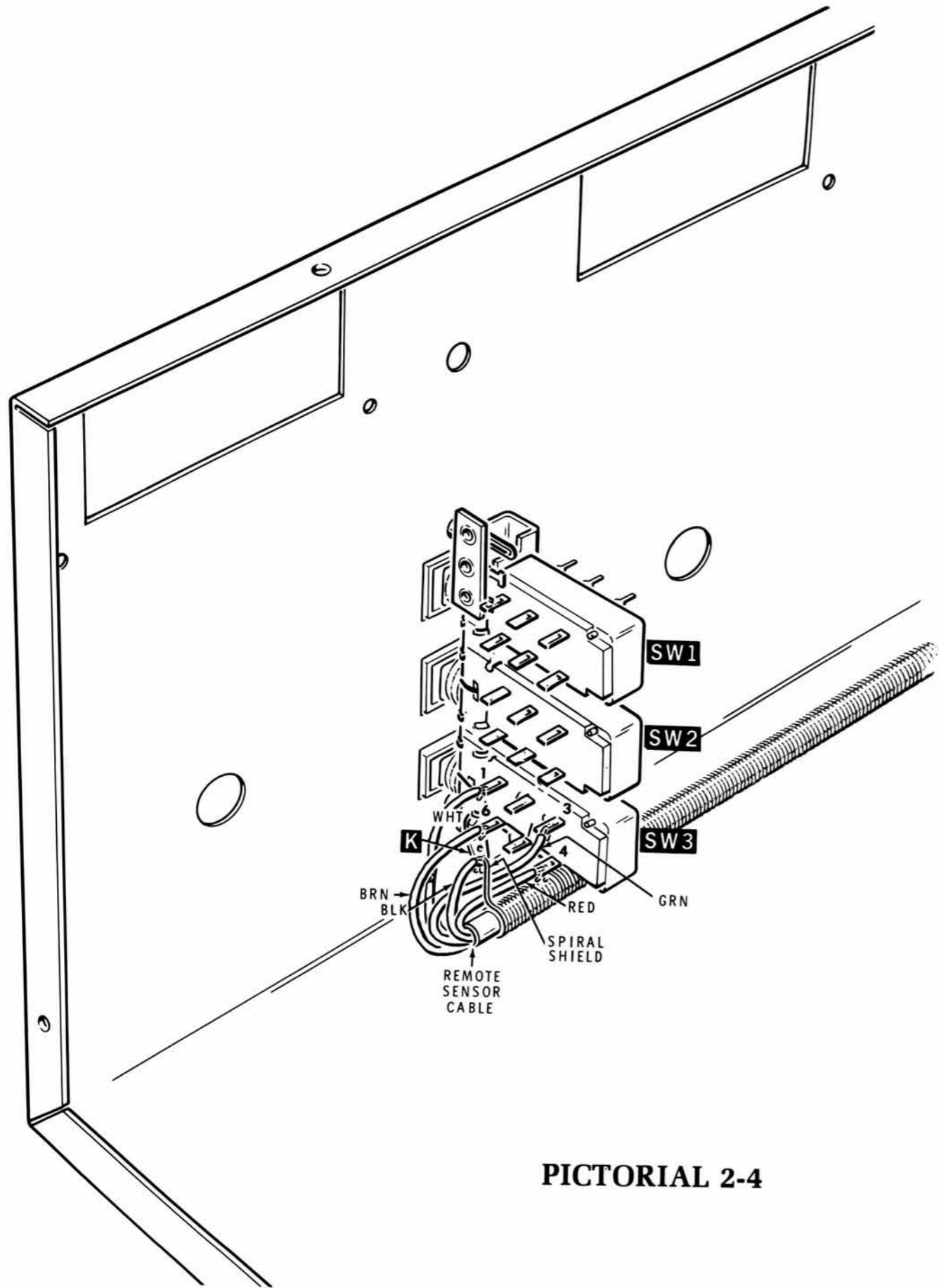

PICTORIAL 2-4

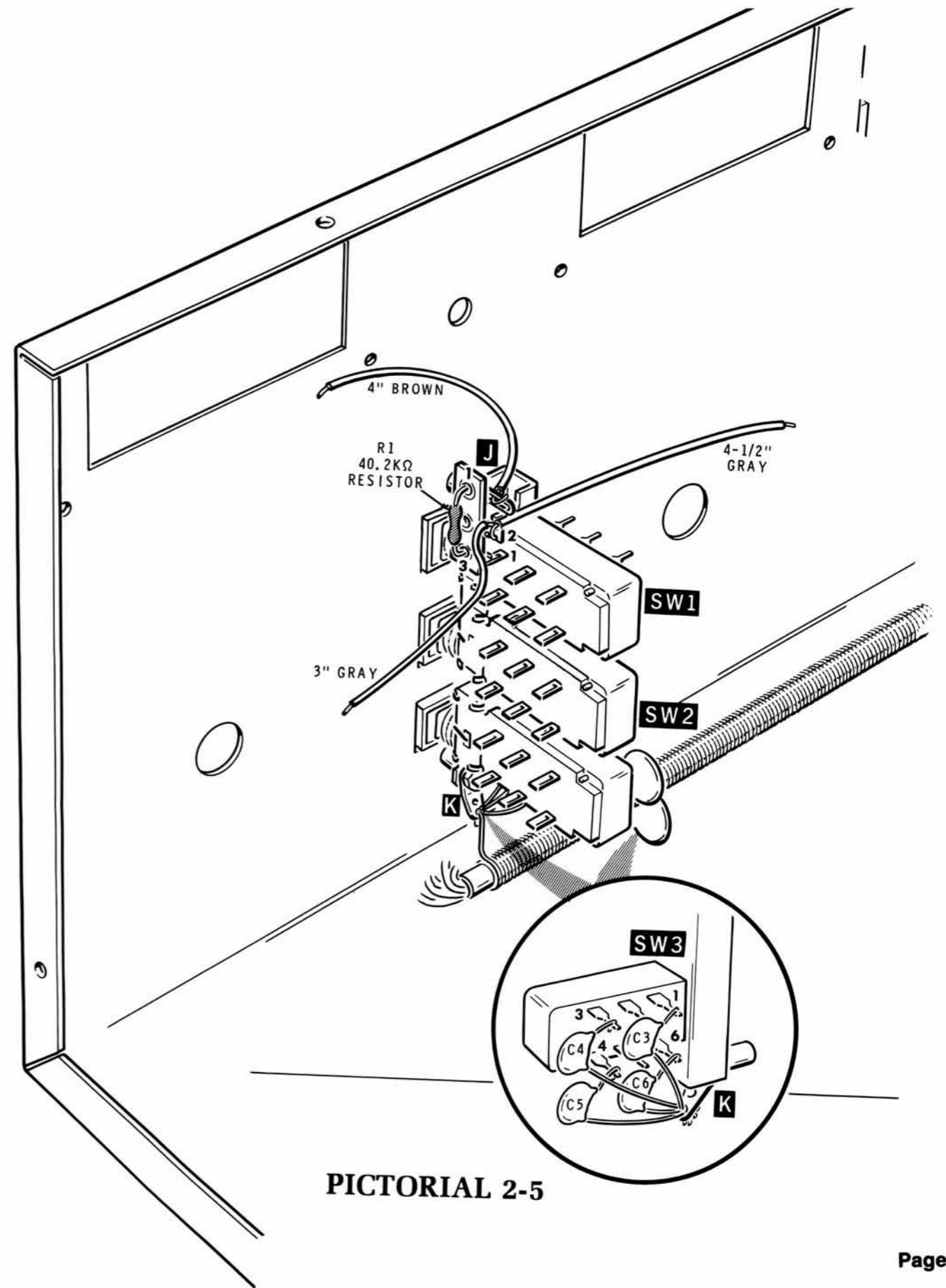

PICTORIAL 2-5

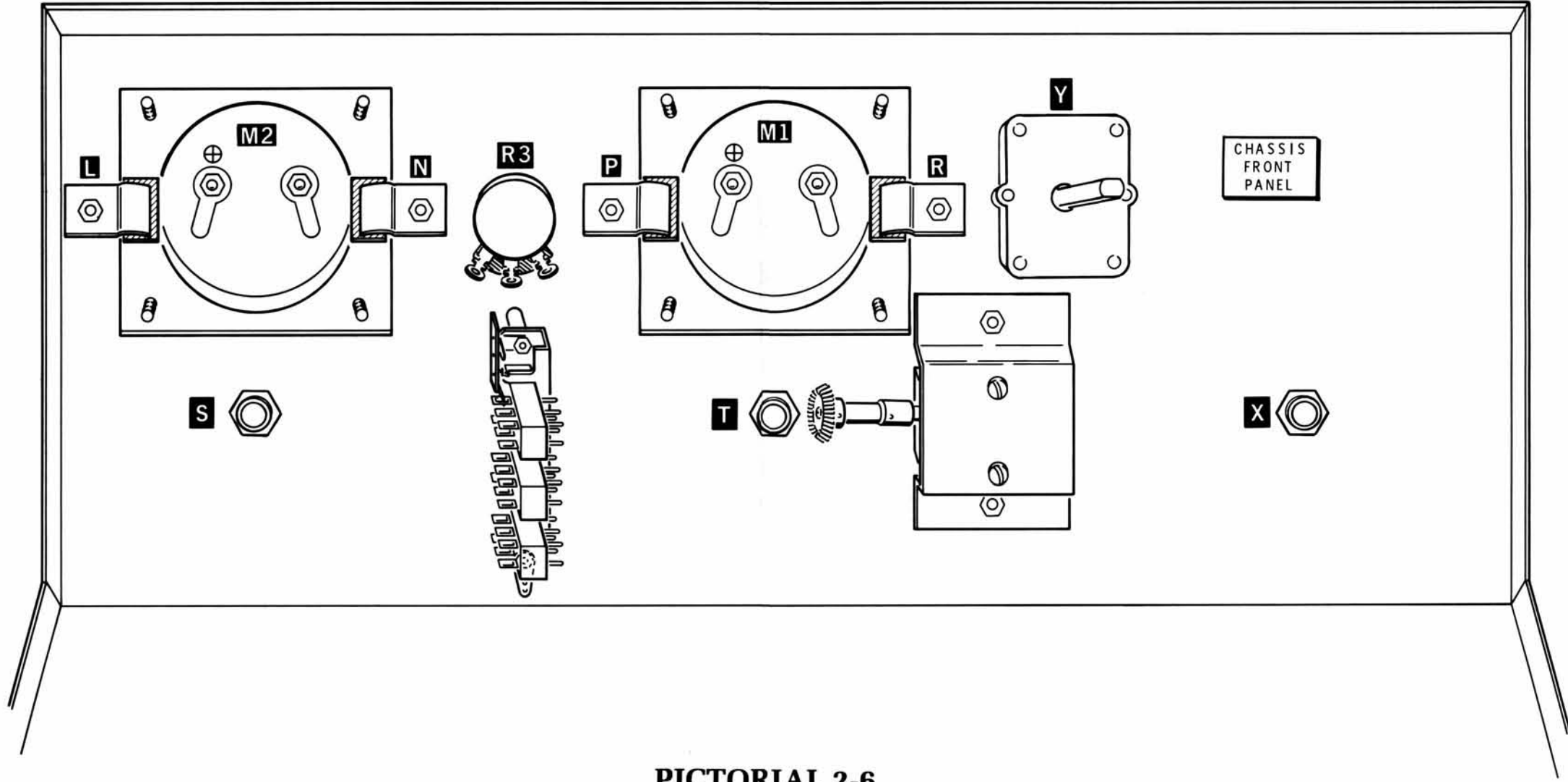

PICTORIAL 2-6

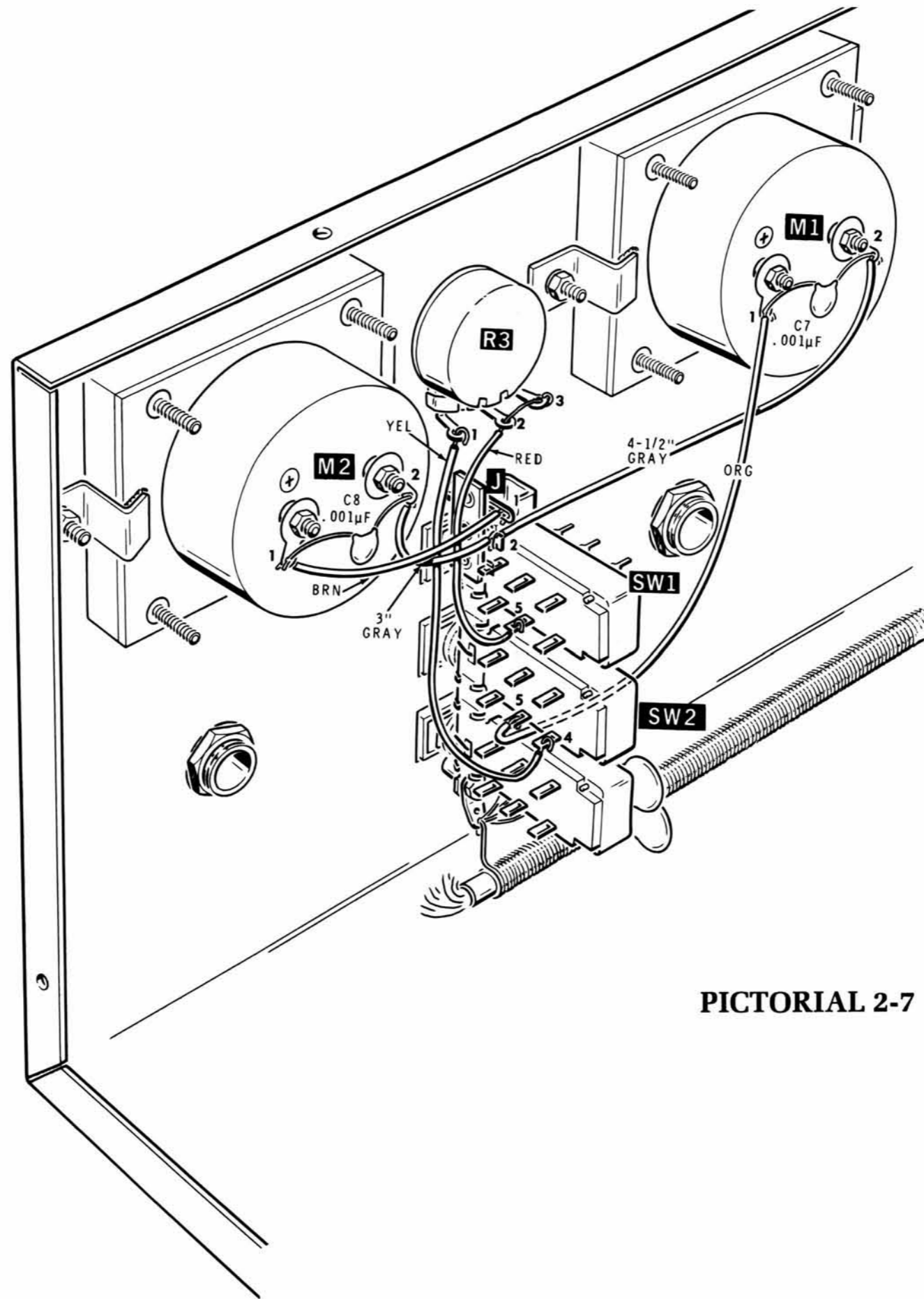

PICTORIAL 2-7

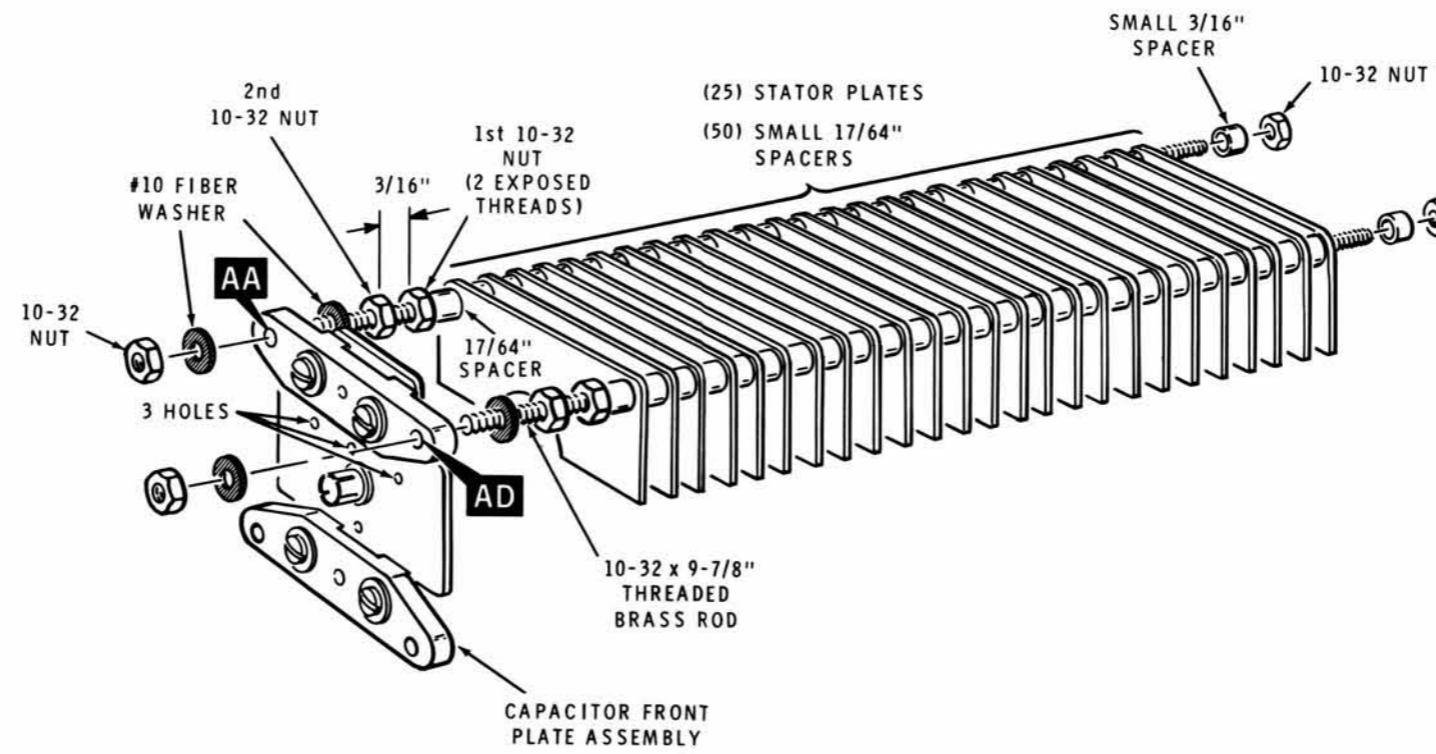

PICTORIAL 3-2

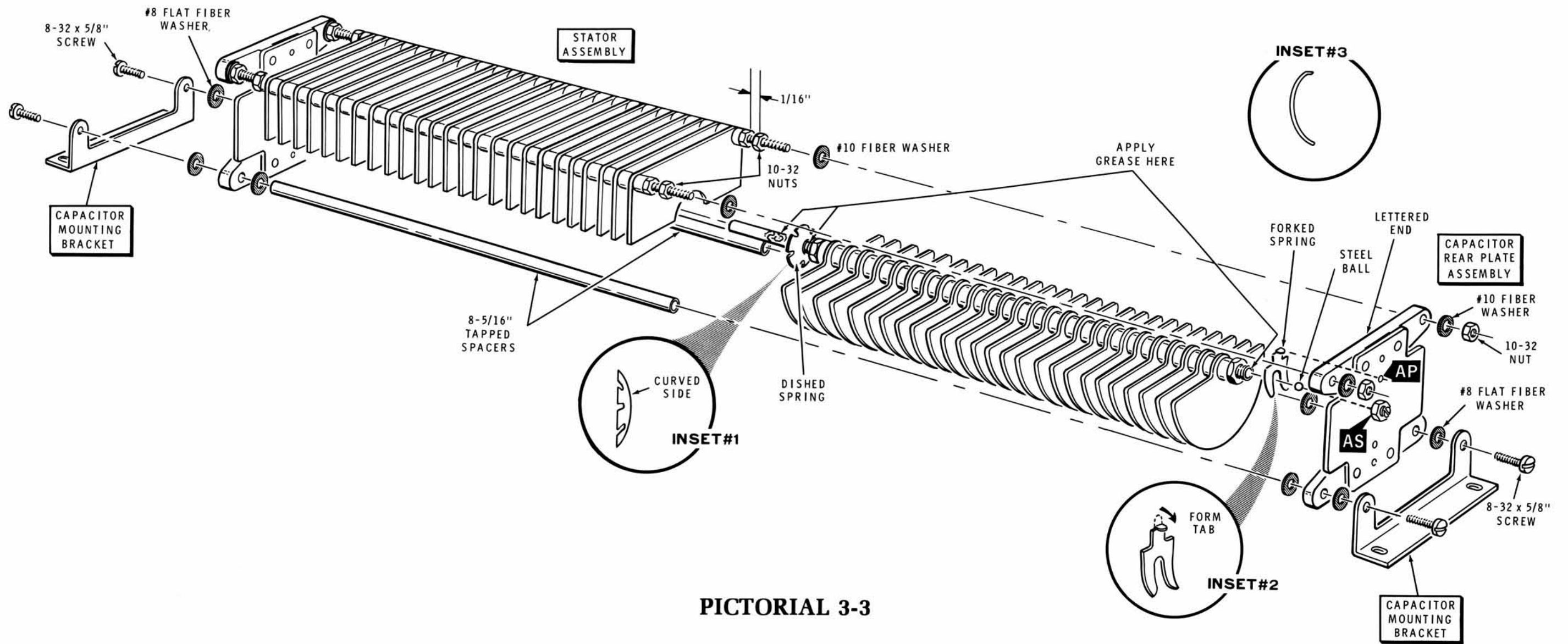

PICTORIAL 3-3

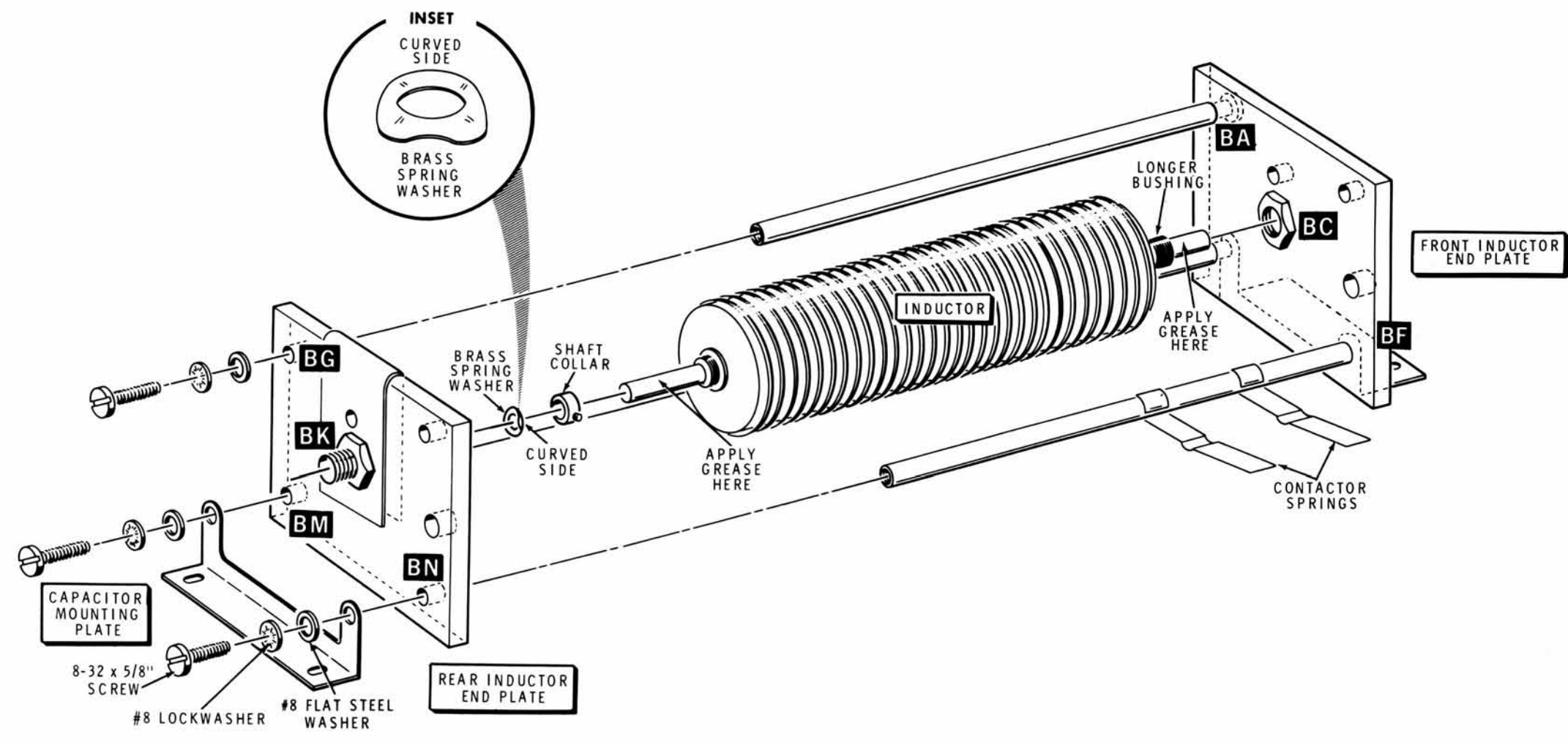

PICTORIAL 4-1

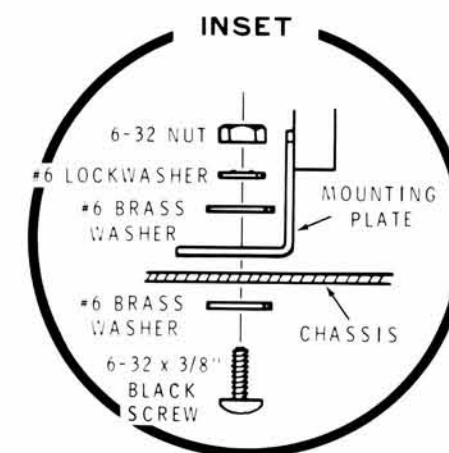
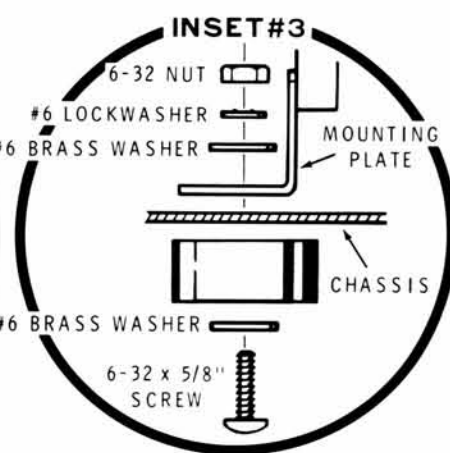
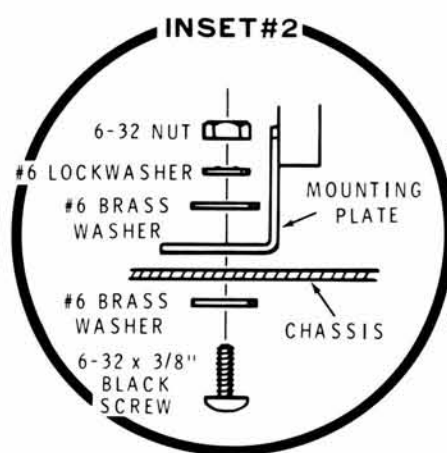
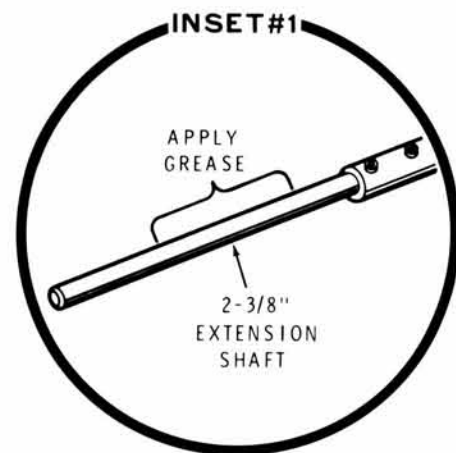
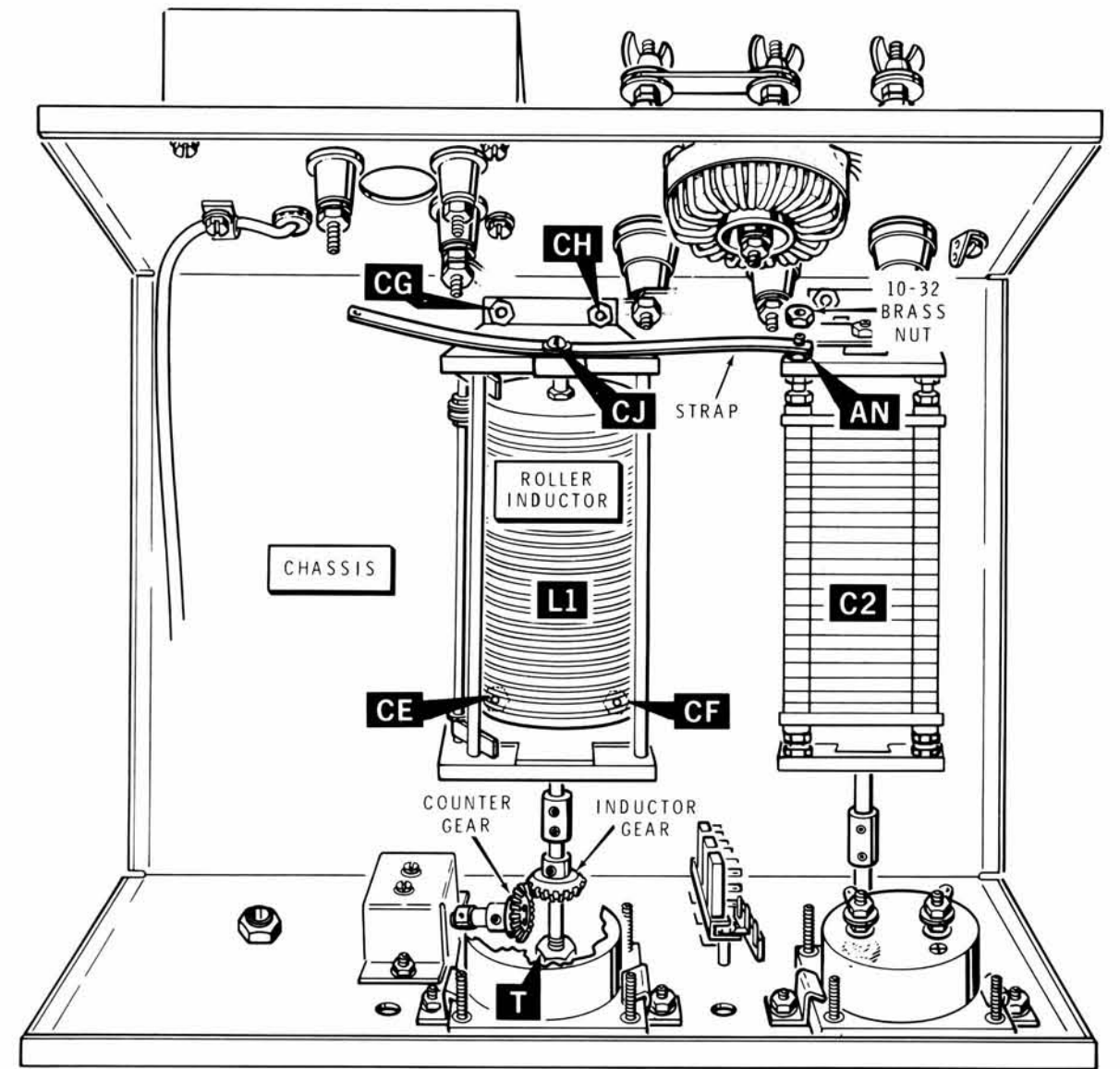
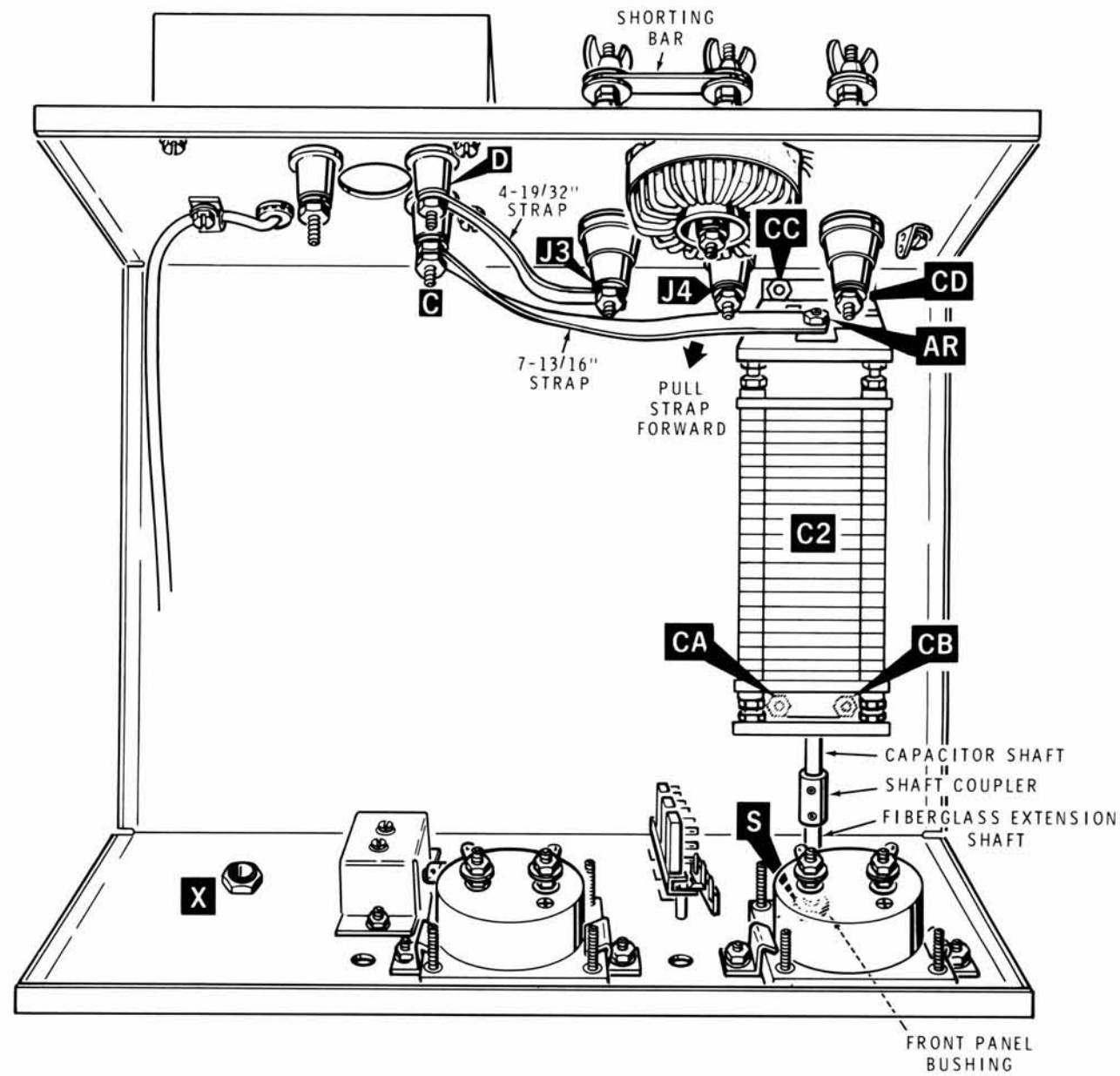

PICTORIAL 6-2

PICTORIAL 6-3

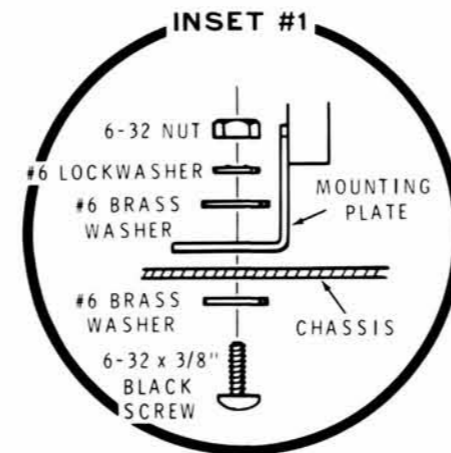
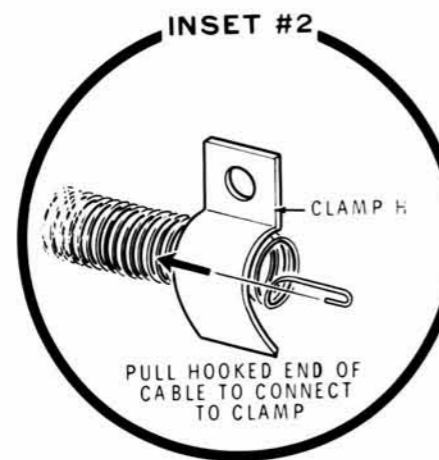
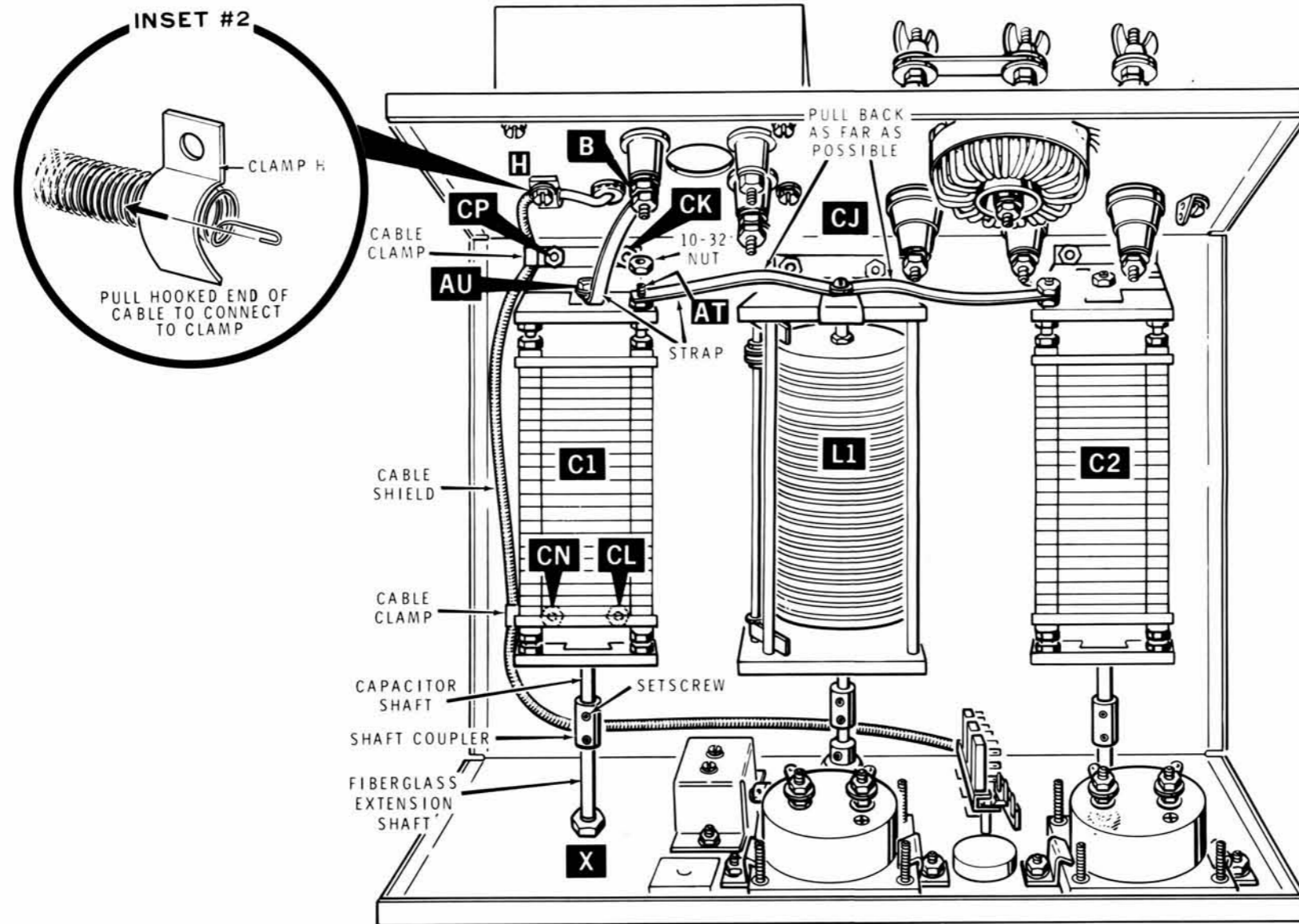

PICTORIAL 6-4

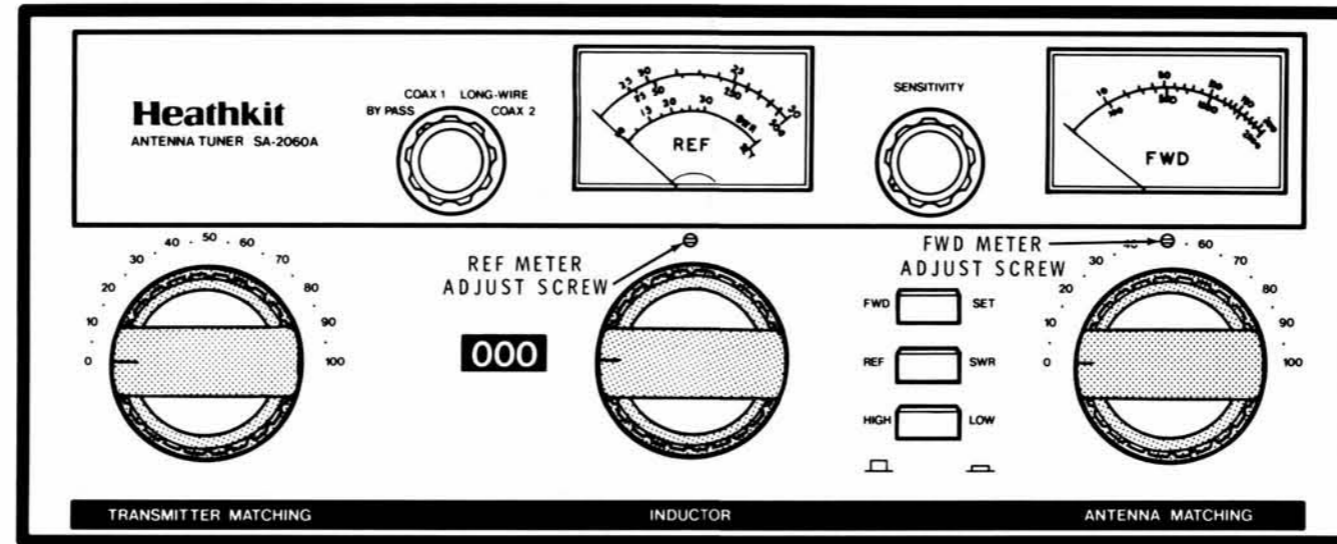

PICTORIAL 8-1

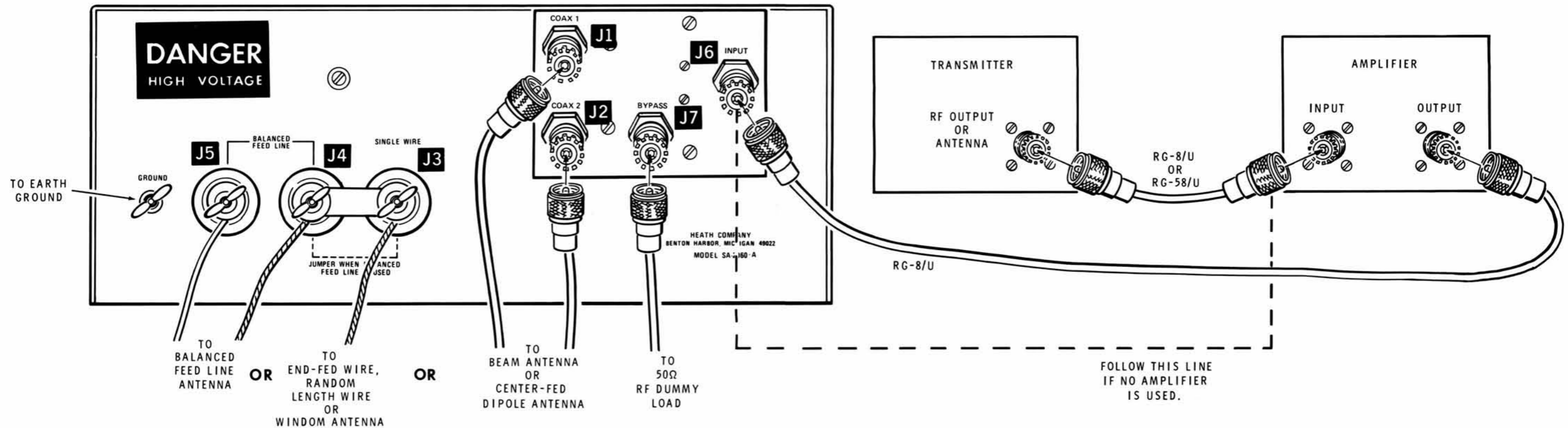

PICTORIAL 8-2

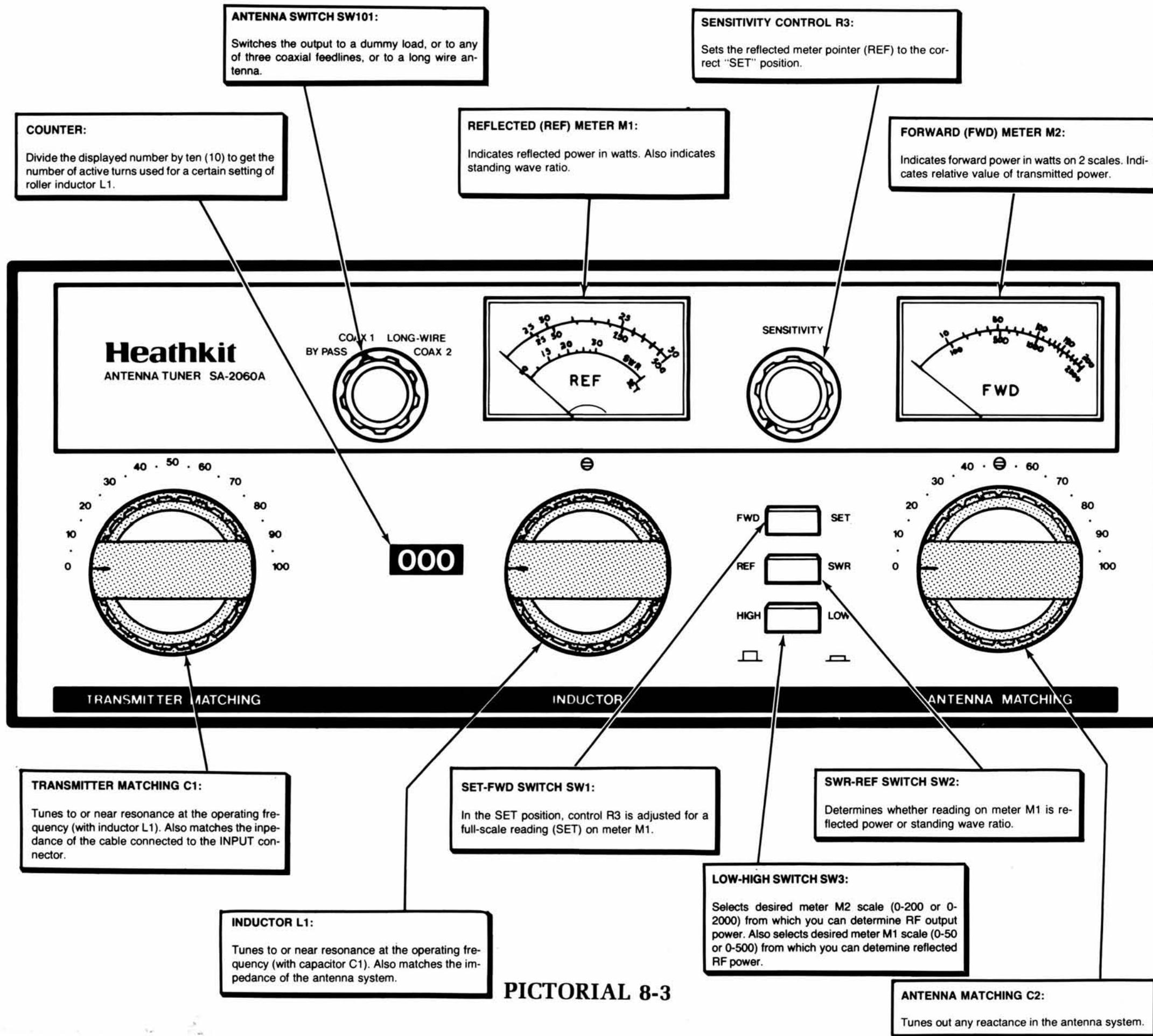

PICTORIAL 8-3

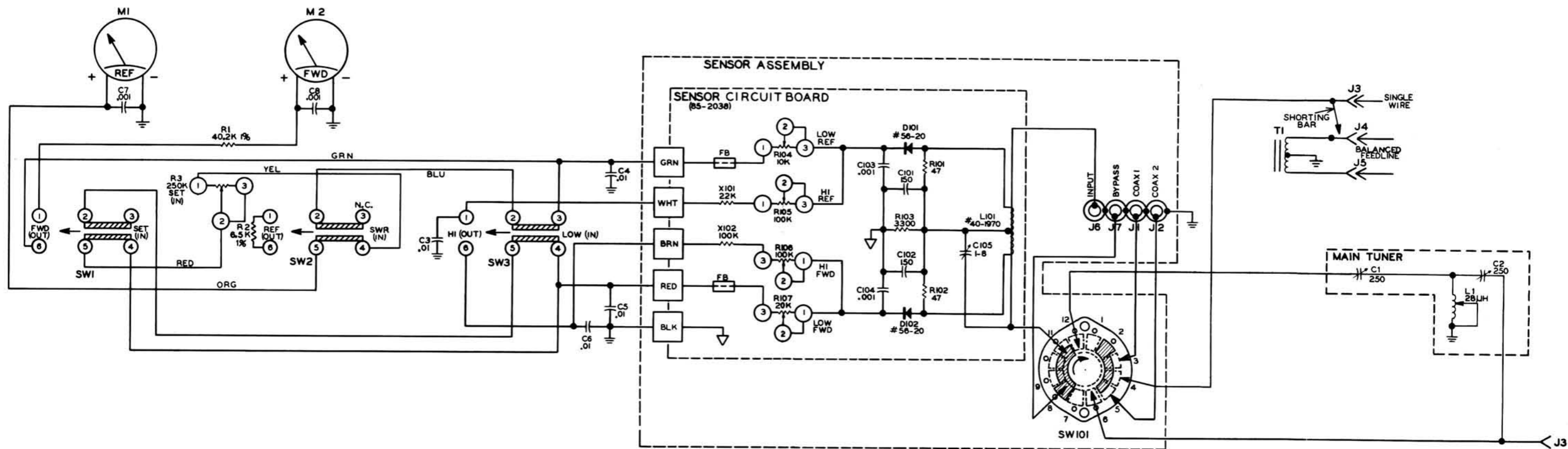

**SCHEMATIC OF THE
HEATHKIT®
DELUXE ANTENNA TUNER
MODEL SA-2060A**

NOTES:

1. ALL RESISTOR VALUES ARE IN OHMS (Ω);
(K=1000).
2. ALL RESISTORS ARE 1/4-WATT, 5% TOLERANCE
UNLESS OTHERWISE NOTED.
3. CAPACITOR VALUES LESS THAN 1 ARE IN μ F (MICRO-
FARADS). VALUES OF 1 OR GREATER ARE IN pF
(PICOFARADS) UNLESS OTHERWISE MARKED.
4. \perp THIS SYMBOL INDICATES A CHASSIS GROUND.
5. ∇ THIS SYMBOL INDICATES A CIRCUIT BOARD
GROUND.
6. \square THIS SYMBOL INDICATES A CIRCUIT BOARD
WIRE CONNECTION.
7. SWITCH SW101 SHOWN IN BYPASS POSITION.

