

TEN-TEC
TEN - TEC

**OPERATOR'S
MANUAL**

**MODEL 238
ANTENNA TUNER**



TABLE OF CONTENTS

<u>PARAGRAPH</u>	<u>PAGE</u>
LIST OF ILLUSTRATIONS	ii
SPECIFICATIONS	iii
INTRODUCTION	iv
UNPACKING	iv
1. INSTALLATION	
1-1 INTRODUCTION	1-1
1-2 TRANSMITTER CONNECTIONS	1-1
1-3 GROUND CONNECTIONS	1-1
1-4 ANTENNA CONNECTIONS	1-1
2. OPERATING INSTRUCTIONS	
2-1 INTRODUCTION	2-1
2-2 FRONT PANEL CONTROL FUNCTIONS	2-1
2-2.1 CAPACITOR	2-1
2-2.2 INDUCTOR	2-1
2-2.3 IMPEDANCE SWITCH	2-1
2-2.4 METER SWITCHES	2-1
2-2.5 SWR SET	2-1
2-3 ANTENNA MATCHING	2-1
2-4 ANTENNA SELECTION	2-2
2-5 POWER-SWR METER	2-2
2-6 OPERATING HINTS	2-3
2-7 ANTENNA SYSTEMS MATCHING THEORY	2-3
2-7.1 THE ANTENNA	2-3
2-7.2 THE TRANSMISSION LINE	2-4
2-7.3 EFFECT OF TRANSMISSION LINE ON ANTENNA IMPEDANCE	2-6
2-7.4 STANDING WAVE RATIO	2-6
2-7.5 OVERALL SUMMARY	2-7
2-8 ALIGNMENT AND CALIBRATION	2-7
2-8.1 SWR BRIDGE	2-7
2-8.2 WATTMETER CALIBRATION	2-8
2-9 PILOT LAMP REPLACEMENT	2-8
2-10 DIAL STRING REPLACEMENT	2-8
3. ILLUSTRATIONS AND CIRCUIT SCHEMATICS	
3-1 INTRODUCTION	3-1
3-2 CIRCUIT DESCRIPTION	3-3
3-3 SWR BOARD (80859)	3-5
3-4 SWITCH BOARD (80911)	3-7
3-5 TUNER CONFIGURATIONS	3-9

LIST OF ILLUSTRATIONS

<u>FIGURE</u>		<u>PAGE</u>
2-1	MODEL 238 FRONT PANEL	2-9
2-2	MODEL 238 REAR PANEL	2-10
2-3	DIAL STRING ROUTING DIAGRAM	2-10
3-1	MODEL 238 SCHEMATICS AND WIRING DIAGRAM	3-2
3-2	80859 SWR BOARD CIRCUIT TRACE	3-5
3-3	80859 SWR BOARD COMPONENT LAYOUT	3-5
3-4	80911 SWITCH BOARD CIRCUIT TRACE	3-7
3-5	80911 SWITCH BOARD COMPONENT LAYOUT	3-7
3-6	MODEL 238 TUNER CONFIGURATION DIAGRAMS	3-9

SPECIFICATIONS

CIRCUIT TYPE:	Modified "L" network.
RF POWER RATING:	2 kW maximum.
FREQUENCY RANGE:	1.8 to 30 MHz.
OUTPUT MATCHING RANGE:	At least 10:1 SWR, any phase angle, 1.8 to 30 MHz. 3000 ohms maximum at full power.
INPUT IMPEDANCE:	50 ohms, nominal.
CAPACITOR VOLTAGE RATING:	3.5 kV.
INDUCTOR:	18 μ h silver plated roller inductor.
SIZE:	HWD 5.5" x 13" x 11", overall (14 x 33 x 28 cm).
WEIGHT:	10 lbs, (4.53 Kg).

INTRODUCTION

The Model 238 Antenna Matching unit is an adjustable reactive network used for matching the unbalanced 50 ohm output impedance of transmitters and transceivers to a variety of balanced and unbalanced loads. It

will perform this function over a frequency range of 1.8 to 30 MHz. Provision is made for selecting one of four antennas or for by-passing the matching network. A dual range power and SWR meter is included.

UNPACKING

Carefully remove the antenna tuner from the packing carton and inspect it for signs of shipping damage. If the antenna tuner has been damaged, notify the delivering carrier immediately, stating the full extent of the damage. Save all damaged cartons and packing material. Liability for any shipping damage rests with the carrier. Complete the warranty registration form and mail to TEN-TEC immediately.

Save the packing material for re-use in the event that moving, storage, or reshipment is necessary. Shipment of your TEN-TEC antenna tuner in other than factory packing

may result in damage which is not covered under warranty. The following hardware and accessories are packed with your Model 238. Make sure you have not overlooked anything.

1 — #23160	Capacitor, 1000 pf, 500V
1 — #38040	.050" Hex Allen Wrench
1 — #38088	.062" Hex Allen Wrench
1 — #74020	Warranty Card
1 — #74194	Operator's Manual

If any of the above items are missing, contact the customer service department at Ten-Tec for replacements.

CHAPTER 1

INSTALLATION

1-1 INTRODUCTION The Model 238 Antenna Tuner may be set up in any convenient location in your shack. The following sections describe the required connections.

1-2 TRANSMITTER CONNECTIONS

The Model 238 is designed for connection to transmitters having a 50 ohm nominal output impedance. Connect the coaxial output of your transmitter to the INPUT connector on the rear panel of the tuner with a short length of RG-8 or RG-58 cable. The connector is an SO-239 type. **Note:** To reduce possibility of rf getting into the transmitter, position tuner as far away from transmitter as is practical, especially when using a long wire antenna.

1-3 GROUND CONNECTIONS Connect the station ground buss to the GROUND terminal on the rear panel of the tuner with heavy metallic braid or wire. This lead should go directly to the earth ground system with as short a lead as possible.

1-4 ANTENNA CONNECTIONS Connect antenna transmission line(s) to the appropriate terminal(s) on the tuner as follows:

- A. For coax-fed antennas (unbalanced transmission lines), use either ANT 1, ANT 2, ANT 3 or ANT 4.
- B. For a single wire antenna, connect to SINGLE WIRE terminal.
- C. For balanced feed line systems, add a jumper from SINGLE WIRE to one of the BALANCED LINE terminals using a short wire. Then, connect the feed line to the two BALANCED LINE terminals.
- D. ANT 4 position can be coax, single wire or balanced line. ANT 1, 2 or 3 must be coax only.

In both single wire and balanced line systems, take special care to route the transmission line as far away from station equipment as possible. Never drape lines over the transmitter. These lines may have high voltage points inside the shack which can produce strong rf fields.

NOTE: The SWR bridge power meter is in the circuit at all times, even in the BY-PASS position.

If you wish to light the meter and panel lamps you must connect a source of +11 to +13.5 Vdc to the 13.5 VDC (METER LIGHTS) connector on the rear panel.

CHAPTER 2

OPERATING INSTRUCTIONS

2-1 INTRODUCTION The following instructions will enable the operator to quickly place the Model 238 Antenna Tuner into operation. Included are descriptions of the Front Panel controls and their functions. This is followed by instructions for antenna matching and selection, operating hints, and a discussion on antenna systems matching theory. Also included are instructions for the replacement of the pilot lamps and dial string.

2-2 FRONT PANEL CONTROL FUNCTIONS The following sections describe the front panel controls and their function.

2-2.1 CAPACITOR This control connects to the variable tuning capacitor, C2, which is used as one of the elements in the "L" type matching network. This capacitor has a tuning range of 40-500 pF and has continuous tuning with no stops.

2-2.2 INDUCTOR This control is connected to the roller inductor, L2, which is also part of the matching network. This inductor has a tuning range of approximately .2-18 μ H which is covered in approximately 27 revolutions of the control knob. There is a mechanical limit stop at each end of its travel.

2-2.3 IMPEDANCE SWITCH This eleven position rotary switch is used to change the configuration of the tuning network for matching either low or high impedance antenna systems. This switch also selects in

additional capacitors as needed for matching at lower frequencies. When placed in the 12 o'clock position, the tuner is connected in the BYPASS configuration and the network has no effect on the transmission line system.

2-2.4 METER SWITCHES The meter functions are determined by a bank of three latching push-button switches. The left-most switch is the FWD/REV switch and is used to determine whether the meter is reading forward or reflected signal coming from the SWR bridge circuit. The center switch is labeled 2KW/200W and selects the full scale range of the meter readout. The right-most switch is PWR/SWR and is used to select between the power or SWR modes of operation.

2-2.5 SWR SET This potentiometer is used to adjust the sensitivity of the meter output circuit when you wish to determine the SWR. To use this control place the meter switches in FWD and SWR positions. The range switch can be in either the 2KW or 200W position since it is not used for measuring SWR. Next key the transmitter and adjust the SWR SET control for a full scale deflection. While still transmitting, place the meter switch in the REV position and read the SWR from the meter scale.

2-3 ANTENNA MATCHING The procedure shown below will enable you to quickly match almost any antenna system. Always use the minimum transmitter power necessary to

operate the SWR/POWER meter. To do this proceed as follows:

1. Set the meter switches to REV and SWR and turn the SWR SET to full clockwise position.
2. Set the CAPACITOR to 2, the INDUCTOR to full scale (full clockwise) and S1 to 50 ohms BYPASS.
3. Apply enough transmitter drive to obtain a half-scale meter reading.
4. Switch to both sides of the BYPASS position to determine which results in a lower meter reading and leave it there.
5. Alternately adjust the CAPACITOR and INDUCTOR for lowest meter reading.
6. If the CAPACITOR shows best meter null at 0, turn S1 to the other side of 50 ohms BYPASS.
7. If the best meter null is with the CAPACITOR at 10, turn S1 to the next higher position.
8. Once a null is reached, to determine if the SWR is sufficiently low, set the meter switch to FWD and adjust the SWR SET control to the full scale SET mark. Switch back to REV and read SWR on the lower meter scale. A reading less than 1:5 is usually acceptable.
9. It is convenient to record the control settings for each antenna and band. Tune up on a given band will be simplified by having the settings already established.

2-4 ANTENNA SELECTION A maximum of four antennas may be connected to the Model 238 at one time, only one of which may

be a wire fed antenna. Whether the antenna selected is matched or fed directly is determined by the setting of S1. The 50 ohms BYPASS position bypasses only the matching network, leaving the SWR-POWER meter in line.

Antenna position 4 feeds ANT 4, SINGLE WIRE or with jumper, BALANCED LINE. Only one antenna, coax, single wire or balanced line feed may be attached at one time to these outputs; otherwise, the antennas will be fed in parallel and the lowest impedance antenna will receive the most power. When using either ANT 4 (coax) or the SINGLE WIRE terminal, **do not** connect the jumper between SINGLE WIRE and one BALANCED LINE terminal as damage to the balun may result.

2-5 POWER-SWR METER The meter circuit allows measurement of forward and reverse power in two ranges, 0 - 200 W and 0 - 2 kW. Measuring SWR is covered in step 8 above.

CAUTIONS

1. IN THE NORMAL OPERATION OF THE MODEL 238 MATCHING UNIT, VERY HIGH RF VOLTAGES AND CURRENTS CAN OCCUR AT SOME POINTS IN THE CIRCUIT. BE VERY CAREFUL IF THE TUNER IS EVER USED WHILE THE COVER IS REMOVED.
2. WHILE ALL THE COMPONENTS ARE RATED TO EASILY HANDLE CONTINUOUS OPERATION AT MAXIMUM POWER, CERTAIN LOADS WILL PRODUCE CURRENTS WHICH EXCEED THE "HOT SWITCHING" CAPABILITIES OF THE CERAMIC WAFER SWITCHES. THEREFORE, NEVER CHANGE

THE POSITION OF EITHER SWITCH WITH HIGH RF POWER APPLIED. HOWEVER, UP TO 100 W RF MAY BE HOT SWITCHED ON S1 DURING THE INITIAL TUNE UP PROCEDURE. FAILURE TO OBSERVE THIS WARNING MAY RESULT IN PERMANENT DAMAGE TO THE CONTACTS OF THE WAFER SWITCHES.

3. ALWAYS BE SURE THAT A DUMMY LOAD OR ANTENNA IS PROPERLY CONNECTED WHEN POWER IS APPLIED. VOLTAGES IN EXCESS OF RATINGS CAN OCCUR IF NO LOAD IS CONNECTED.

2-6 OPERATING HINTS If it is noticed that placing your hand on the top of the tuner causes a shift in SWR, it is an indication of excessive "rf in the shack". Improve the ground system or change the length of the feedline slightly. This is especially noticeable when using wire-fed antennas.

When using BALANCED LINE, if the SWR rises during a long transmission, it is an indication that a significant portion of the transmitter power is being lost in the balun. This will be the case when the antenna impedance is greater than 500 ohms. Changing the length of the antenna and/or feedline will usually cure this problem.

160 METER NOTE:

Some low impedances on 160 meters may require more capacitance than the 2400 pf available with the capacitor at full mesh and S1 at position 5 on the LOW Z side. Under such a condition, adding an additional 1000 pf (.001 μ f) 1 KV capacitor across the variable capacitor will usually produce a perfect match. A low loss ceramic or mica transmitting capacitor should be used. A ceramic capacitor is included for your use. If needed, install the capacitor by connecting one lead to the EX-

TERNAL CAPACITOR terminal (on the rear panel) and the remaining lead to a ground lug located below the capacitor terminal.

2-7 ANTENNA SYSTEMS MATCHING THEORY Most transmitters are designed to work into a 50 ohm resistive load, and they are not able to effectively supply rf power to loads that depart far from this value. However, many antenna systems, which include the antenna and the transmission line, have complex impedances that make it difficult if not impossible to load the transmitter properly. These impedances are a function of the operating frequency, type of antenna, type and length of transmission line, height of antenna and its proximity to other objects.

The Model 238 provides a coupling method to convert the resistive/reactive load to a pure resistance of 50 ohms that will accept maximum power from the transmitter. This is not to say that any and all antennas, when converted to a 50 ohm resistive impedance by means of a tuner, will give identical performance. To best understand the tuner adjustments required, it is necessary to have a fundamental knowledge of how antenna systems function. To this end, a short technical discussion follows. It is recommended that additional reading on the subject be done by those interested in obtaining maximum performance from their antenna systems. The ARRL Antenna Handbook, ARRL Radio Amateur's Handbook (antenna and transmission line sections) and other antenna books published by the publishers of amateur radio magazines are excellent sources of information.

2-7.1 THE ANTENNA Any conductor that has rf currents flowing in it can be looked on as an antenna or radiator. The extent to which power leaves the conductor and radiates into the surrounding medium depends on many factors — length, frequency, amount of current, configuration, etc. Since the antenna

absorbs power from the device feeding it, it can be replaced with a resistance whose value is such that the power delivered to this resistance is the same as that delivered to the antenna. The value of this resistance is now a measure of the radiating effectiveness of the antenna and is termed "radiation resistance". For a given value of antenna current, the higher this resistance, the more power that is radiated. ($P=I^2R$)

Due to the facts that an antenna has physical length, that currents travel at a velocity less than instantaneous and that the conductor possesses a certain amount of self-inductance and capacitance, the current at the feed point may not be in phase with the voltage at this point. As a result, the impedance at this point may not look like the pure resistance first suspected, but as an impedance consisting of resistance and either inductive or capacitive reactance. This added reactance will limit the amount of current supplied to the antenna for a given voltage, and therefore reduce the amount of radiated power. The reactance does not absorb power in itself — only a resistance can do that — but its presence reduces the overall radiated power and antenna current.

There are two ways to restore the power to its non-reactive value. The first, which is not the preferred way because it does not maximize power transfer, is to raise the feed point voltage enough so that the current returns to its original value. The second, and preferred method, is to add a reactance in series, equal in value but opposite in type (sign) to the reactance value of the antenna. For example, if the antenna at the operating frequency presents an inductive reactance of 100 ohms (+j100) along with a resistance of 50 ohms, inserting a capacitor whose reactance is also 100 ohms (-j100) in series has the effect of cancelling out the reactance of the antenna, leaving only the 50 ohms resistive. This can be looked on as a series R,L,C circuit that is in

resonance, whose total impedance is only that of the resistance. Another term for this approach to maximize power transfer is "conjugate impedance matching".

In the above example, we used a value of 50 ohms for the radiation resistance. If this value were not 50 but 150 ohms, the impedance after cancelling the reactance out would be 150 ohms. Connecting this load to the transmitter designed to operate with 50 ohms load would not result in optimum power transfer. It would, however, be better than leaving the inductive reactance in, since the antenna current is maximized for the conditions that do exist. To obtain design performance, it is necessary to transform the 150 ohms to 50 ohms. This can be done with a transformer with a turns ratio of 1.73 to 1. (Impedance transformation is equal to the square of the turns ratio). It is also possible to accomplish this transformation with a parallel tuned circuit with primary and secondary taps properly located on the inductor, or using two or more capacitors in series with taps taken from the series string. Under these conditions, the transceiver will deliver rated power to the antenna.

One last observation before we go on. The antenna impedance in the above example was stated as that at the feed point. If we now feed the antenna at a different location along the conductor, the impedance will be different, both resistive and reactive components. There are an infinite number of impedance choices available, depending on where the tap is made. This factor is helpful in designing and matching antennas. The factors that determine this impedance are the current and voltage values at this point, and the phase between them.

2-7.2 THE TRANSMISSION LINE In the above example, we assumed that the transmitter output was connected directly to the feed point. This is hardly practical. So that the

transmitter can be located at a distance from the antenna, we use a transmission line to deliver the power. Unless we have a perfectly matched system, i.e. antenna, line and transmitter output impedances all the same value without reactive components, the addition of the transmission line completely changes the picture. The transmitter will not see the antenna impedance of 50 ohms resistive and 100 ohms inductive reactance, but some other combination. It will depend on the electrical length of the line, its characteristic impedance and frequency. The impedance at the transmitter end is what we are interested in, and the inductive component may even be changed to capacitance. (Only when the electrical length of the line is an exact multiple of the half wavelength will the impedance at the transmitter be the same as the antenna impedance).

Briefly, the line characteristic impedance is determined by the physical dimensions of the line— wire diameter and spacing— and the dielectric of the material in between. The wire also possesses a resistive component which will dissipate power when current flows through it to the antenna. This shows up as heat loss and dictates use of low loss cable. Formulas for coax and open wire line impedances are given in the handbooks.

Since rf currents flow in the transmission line, one may ask if it then becomes an antenna. In the case of coax type lines, the current should flow on the inside surface of the outer conductor and outer surface of the inner conductor. The electric and magnetic fields caused by the current flow are confined between the two, so none can escape and be radiated. If a system configuration results in some rf current flowing on the outer surface of the outer conductor, such as when a dipole is fed with coax without a balun or other means of changing the feed line from an unbalanced to balanced configuration, it will radiate

power. In the case of parallel lines, the current in one conductor at a given location should be flowing in the opposite direction to the current in the adjacent conductor, and if the system is well balanced, the amplitudes of the two will be equal. Under these conditions, the two sets of fields exactly cancel each other and very little radiation will result. If the two currents are not equal or not in exact opposite phase, there will be radiation. Also, if the spacing between lines is a considerable portion of the wavelength, radiation will occur. This is not a factor below VHF frequencies.

One final characteristic of transmission lines should be mentioned. The rf current flowing in the line travels at a speed less than that of radiated power in a vacuum, or the speed of light, both 186,000 miles per second. This slowing is caused by the dielectric property of the medium through which the field traverses. In coax cables it is polyethylene between inner and outer conductors, and in parallel lines, it may be the plastic between the conductors in the case of twin-lead type line, or the air and plastic spacers in open wire types. The ratio of the speed in the line to the speed in a vacuum (air is almost the same) is called the velocity factor of the cable. It is always less than unity. Because of this slowing, the physical length of a transmission line is not the same as the electrical length. For example, the wavelength in free space of a 30 MHz signal is exactly 10 meters. A transmission line 10 meters long will be one full wavelength only if the dielectric between the conductors is air. In the case of coax cable with polyethylene dielectric, the velocity factor runs about 0.67. The same 10 meter length of cable will now appear electrically as an open wire or air dielectric cable 15 meters long (10 divided by 0.67). This is equivalent to one and one half wavelengths. A polyethylene type cable would only have to be 6.7 meters long to be one wavelength.

2-7.3 EFFECT OF TRANSMISSION LINE ON ANTENNA IMPEDANCE As a result of all of the above, in situations where we do not have a matched system throughout, and this is most of the time, the impedance presented to the transmission line by the antenna sets up standing waves on the line. These standing waves will alter the antenna impedance all along the line towards the transmitter. What we really want to accomplish with the antenna tuner is to take whatever impedance that is established at the transmitter end of the line and alter it to a 50 ohm resistance. Then the transmitter will be happy, at least. The tuner will not affect the mismatch of antenna to line — only constructing the antenna differently will do that — nor eliminate a standing wave on the transmission line. It will eliminate a standing wave on the line between transmitter and tuner input, but not on the output side of the tuner. A good antenna is still needed to “get out”. If the antenna has a low resistance, the tuner will transform it, along with the cable loss resistance, to 50 ohms. The full power will enter the system, but it will be divided between radiation and cable heat loss. It is not uncommon that more than half of the available power is wasted in cable losses, even with low loss cable. It just gets a bit hotter. The split depends entirely on the ratio of radiation resistance to loss resistance.

What is the impedance established at the transmitter end of the line? It depends first on the antenna impedance, which is then transformed by the line. This transformation is dependent on frequency, electrical length of the line and the loss in the line. In an amateur setup where many different frequencies are used with the same antenna, there will be a multitude of impedances presented to the tuner, so adjustment of the matching network will be required as frequency is changed.

2-7.4 STANDING WAVE RATIO A measure of how badly a system is mismatched is given by the standing wave ratio (SWR) on the line. SWR is the ratio of the maximum voltage encountered along a transmission line, greater than one half wavelength long, to the minimum voltage. It is also the ratio of maximum to minimum current. The more nearly uniform the voltage distribution along the line, the more closely matched it is, and the ultimate is when the voltage is constant down the length of a lossless line, or drops slowly and uniformly along a line with losses. This is the matched condition, represented by a 1 to 1 SWR. The impedance at the load end of such a line is the same as that at the generator end and maximum power is delivered to the load. When adjusting a matching network properly, the way to do it is to observe the SWR and tune for as low a ratio as possible.

The SWR is also an indication of the value of resistance at the load end. The ratio is the same as the ratio of load resistance to line characteristic impedance. This ratio can mean that the load is either greater than or less than the line's impedance. For example, if the SWR on a length of 50 ohm line is 3 to 1, the load resistance is either 150 ohms or 16.7 ohms (3 times 50 or one-third of 50). This is only accurate with pure resistive loads.

It can be shown mathematically that a 2 to 1 SWR in a system which has the transmitter output impedance equal to the line impedance delivers 89% of the measured forward power to the load. This relates to a power loss of half a decibel — hardly noticeable in signal strength. At a 3 to 1 ratio, the loss becomes appreciable with 75% of the measured forward power delivered. When adjusting antenna tuners, it is a nice feeling if you achieve a 1 to 1 match, but in reality, anything below 2 to 1 is satisfactory. Line losses do increase a bit also with increasing SWR, but it is still a small fraction of a dB at 2:1.

2-7.5 OVERALL SUMMARY

1. Any antenna can be represented as an equivalent resistive/reactive impedance whose resistive component, termed radiation resistance, is a measure of the power radiated. Reactance can be either inductive or capacitive.
2. Antenna impedance is a function of frequency, configuration, selection of feed point location, height above the ground and nearness to surrounding objects.
3. The reactive portion of the impedance does not absorb power but limits the amount of power radiated by the resistive component. It is best to eliminate the reactive component, by inserting an equal value reactance in series, but of the opposite type.
4. Best system performance is attained when antenna impedance is purely resistive with a value equal to the transmission line impedance, which in turn equals the transmitter output impedance.
5. Since antennas seldom present matched impedances to a line over a band of frequencies and from band to band, a partial solution to using these mismatched systems is to convert the impedances at the transmitter end of the line to what the transmitter is designed for, with an antenna tuner.
6. The transmission line will change the antenna impedance in both resistive and reactive values at the transmitter end, depending on the line's electrical length, frequency and characteristic impedance.
7. Due to slowing down of the current flow in the transmission line from that in free space, the electrical length of a line will be longer than the physical length.
8. One special situation where the line does not alter the impedance is when its length is an exact multiple of the electrical half wavelength.
9. An antenna tuner will not affect the antenna impedance nor the standing wave condition on the transmission line. It will correct the SWR on that portion of the line between transmitter output and tuner input, so that the transmitter will supply rated power to the system.
10. Standing wave ratio, SWR, is a measure of the mis-match of the system and is used as the indicator when making tuner adjustments. SWR is the direct ratio of load resistance to a line's characteristic impedance.
11. SWR other than 1 to 1 indicates two possible impedances, one greater and one less than the characteristic impedance.
12. Any SWR value less than 2 to 1 is considered a good match.

2-8 ALIGNMENT AND CALIBRATION

The following sections describe the procedures for aligning and calibrating the SWR bridge and rf wattmeter.

2-8.1 SWR BRIDGE In the unlikely event SWR bridge adjustment becomes necessary, proceed as follows:

1. Connect a 50 ohm dummy load to any antenna jack.

2. Turn the ANTENNA switch to the same antenna position and S1 to 50 ohm BYPASS.
3. Set the meter switches to 200 W, SWR and REV.
4. Turn the SWR SET fully clockwise.
5. Apply power from the transmitter on 14 MHz and adjust the trimmer, C27 on the 80859 SWR BRIDGE circuit board, for a null.

2-8.2 WATTMETER CALIBRATION

To calibrate the built-in wattmeter proceed as follows:

1. Place S1 in the 50 ohm BYPASS position and connect a dummy load to the output.
2. Connect the transmitter through a calibrated wattmeter to the input.
3. Set the meter switches to FWD, 200 W, and POWER.
4. Apply 50 to 100 watts from the transmitter and adjust R30 (on the 80911 SWITCH board) to agree with the external wattmeter.
5. Set the meter switch to the 2 kW range.
6. Apply 500 to 1000 watts from the transmitter and adjust R31 (on the 80911 SWITCH board) to agree with the external wattmeter.

2-9 PILOT LAMP REPLACEMENT

The meter and dial scale lamps are all 14 volt, bayonet type, No. 1813 or 1892. Access to these bulbs is obtained by removing the top cover of the unit.

2-10 DIAL STRING REPLACEMENT

The dial string mechanism consists of two parts - a .020" diameter dacron non-stretchable string and an elastic cord. The diameter of the dacron is important for proper pointer readout, since it is wound on the inductor shaft and carries the pointer across the scale. Replace only with a string of the same diameter. The elastic section provides string tension. Both are available from TEN-TEC. To install, remove the top cover and unplug the meter cable from the 80911 SWITCH board. Remove the knobs and then the front panel. Tie a small loop (about 3/16" diameter) in each end of the elastic cord such that the distance between loops is 16". Tie a loop in one end of the dial string and cut to other end such that the total length is 31". Run the inductor to the full clockwise stop (roller to the rear). Refer to FIGURE 2-3 for the following steps. Place the loop end of the dial string over the steel pin in the roller inductor shaft. Route the dial string in a clockwise direction around the shaft for one full turn, making sure that the string is wrapped in front of the steel pin. Run the dial string down and to the left and around the lower left pulley. From there run the string up and over the top left-most pulley and then right towards the dial pointer. Place the dial pointer all the way to the right in the guide slot. Next run the dial string around the pulley located on the left side of the dial pointer. (Make sure that the string runs over the top of the pulley and exits around the bottom side). Guide the dial string to the left and around the top left inside pulley going around the pulley in a CW direction. Finally run the string to the right and tie it loosely in the hole on the left side of the dial pointer. Leave this knot loose since this is where the dial pointer position will be adjusted later. Hook one of the elastic loop ends over the lower left subpanel standoff, and run the cord across the bottom edge, around the lower right standoff, over the top right standoff and hook the looped end over the right hand pin on

the pointer. This will now have the pointer properly tensioned. Adjust the position of the dial pointer by pulling on the loosened knot located on the left side of the dial pointer. Draw the string tight so that the dial pointer is about 1-1/4" from the upper right standoff. Replace the front panel and inductor knob and turn the inductor to the full counterclockwise stop. While holding the inductor knob, loosen the front setscrew on the front inductor shaft coupler and turn the knob until the dial pointer

lines up with the zero on the dial scale, then tighten the setscrew. Run the inductor through its full range to see that the pointer has free travel and return to the zero point. Loosen the inductor knob setscrew and position the zero mark on the knob skirt at top center and tighten the knob setscrew. Replace the remaining knob, making sure that 10 on the capacitor knob skirt coincides with the fully meshed position of the capacitor.

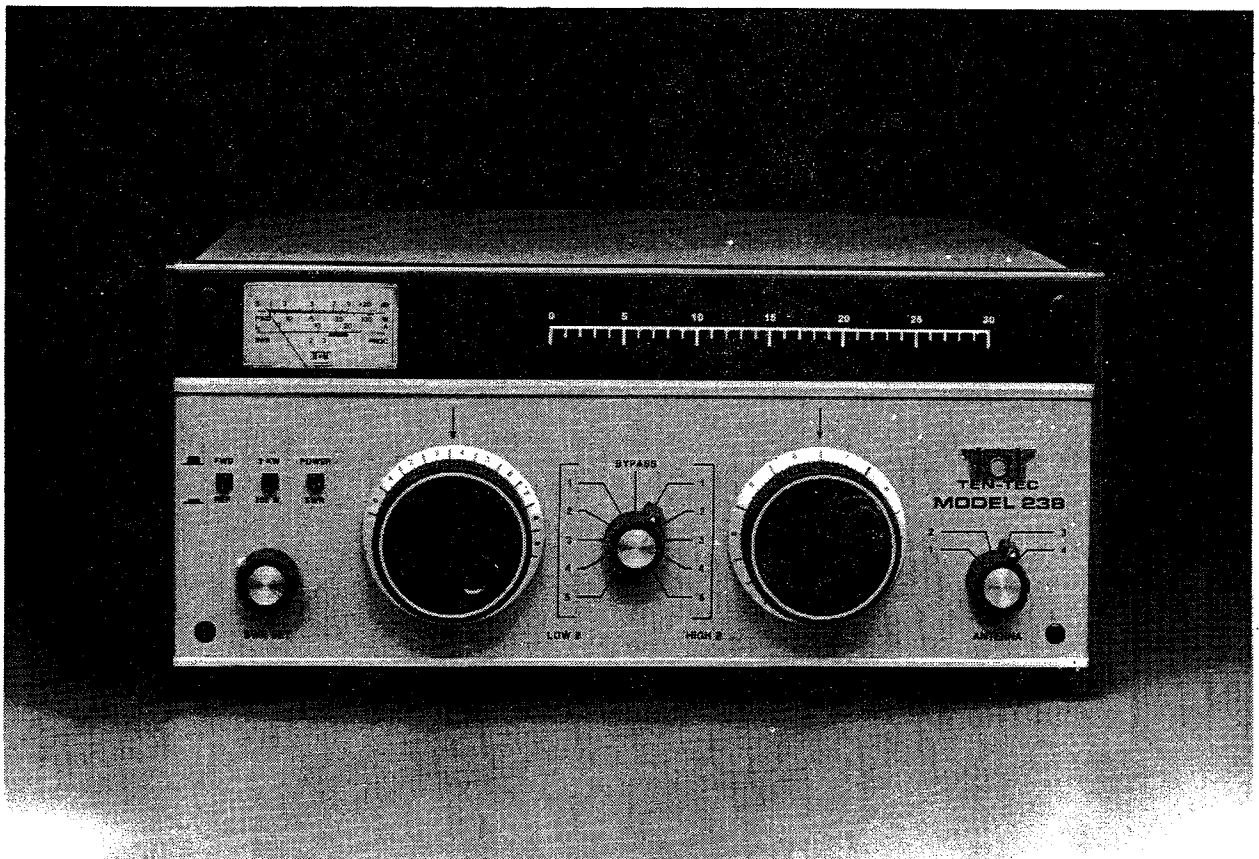

FIGURE 2-1. MODEL 238 FRONT PANEL

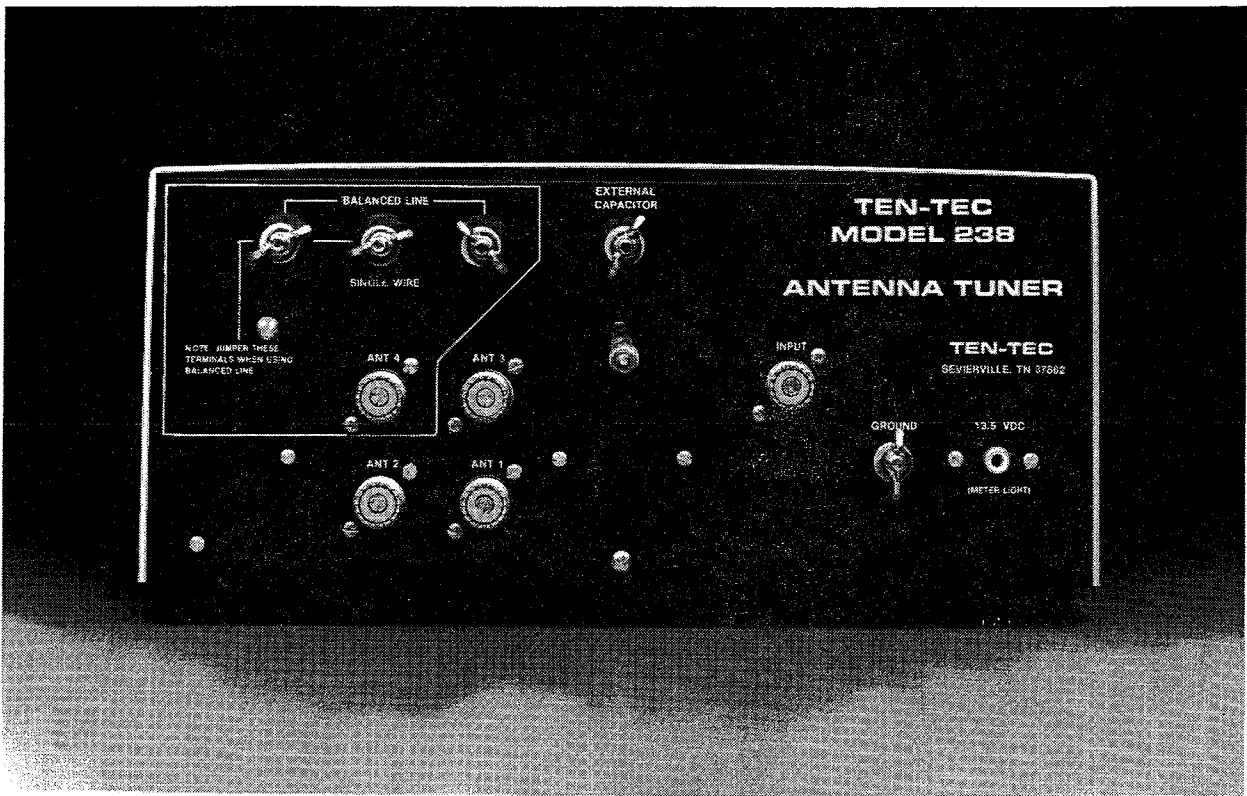

FIGURE 2-2. MODEL 238 REAR PANEL

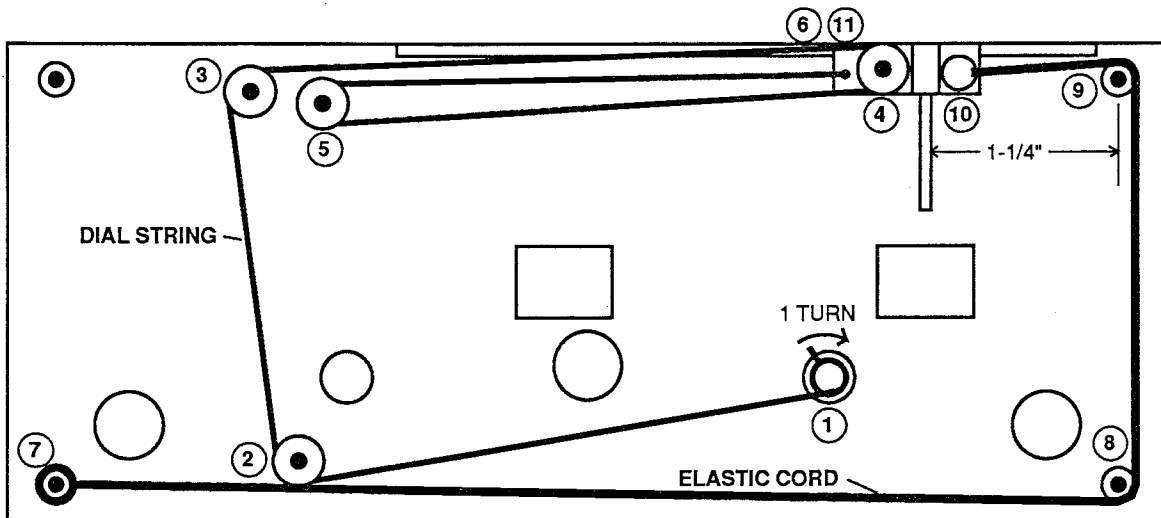

FIGURE 2-3. DIAL STRING ROUTING DIAGRAM

CHAPTER 3

ILLUSTRATIONS AND CIRCUIT SCHEMATICS

3-1 INTRODUCTION The following sections contain circuit trace drawings and detailed component layout diagrams for all of the printed circuit board subassemblies used in the Model 238 Antenna Tuner. Also included is a detailed circuit description and a fold-out schematic diagram of the tuner with each of its circuit board subassemblies.

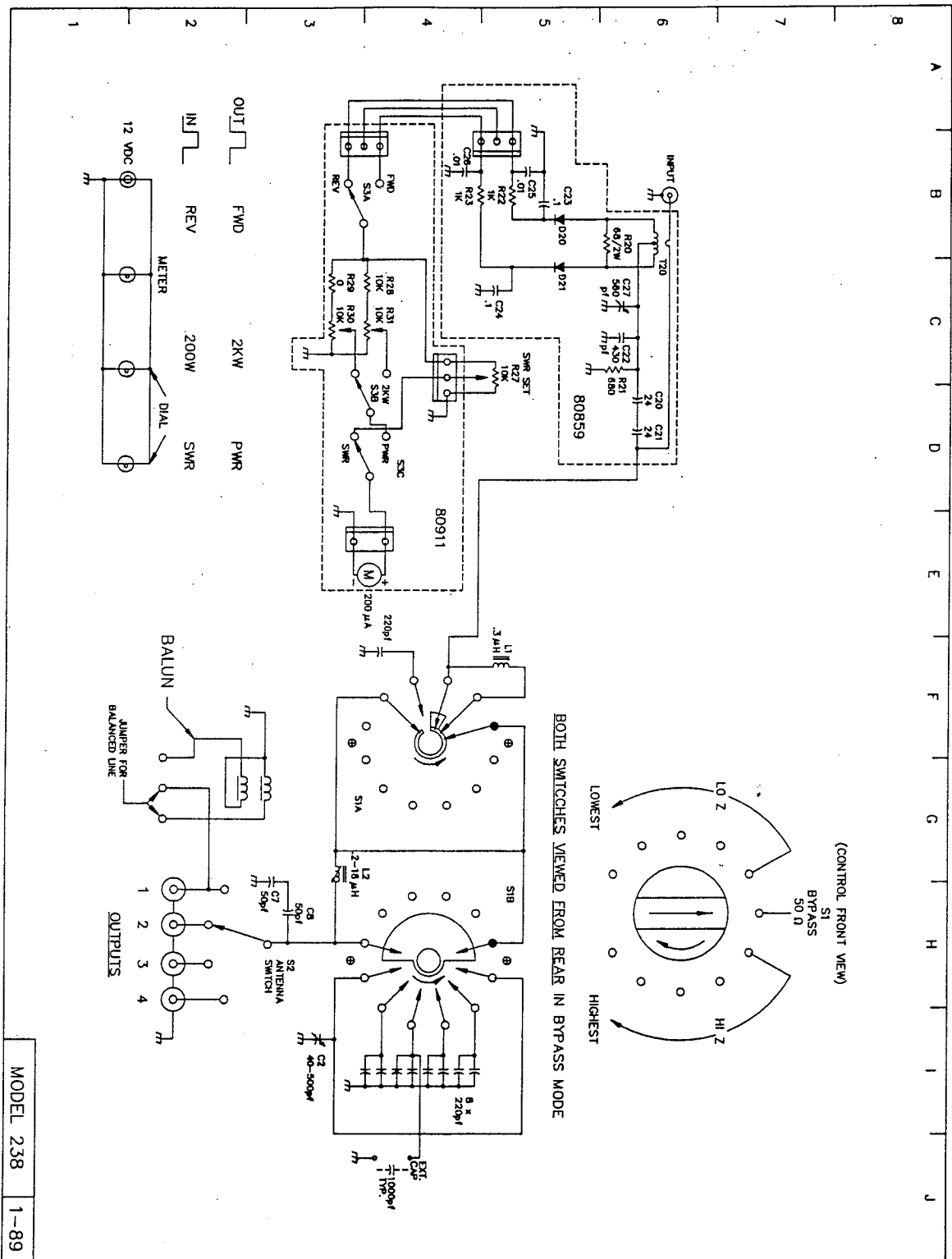

FIGURE 3-1. MODEL 238 SCHEMATICS AND WIRING DIAGRAM

3-2 CIRCUIT DESCRIPTION The matching circuit used in the Model 238 is basically an "L" network. The "L" network has several advantages over other circuit configurations. It has only two adjustable parts, one inductor, L2, and one capacitor, C2; most other networks use three. Because there are no internal nodes in the network, the maximum circuit voltages and currents which occur are never more than those present at the input or output terminals. Because there are only two variable components, there is only one setting of each which will provide a perfect match to a given load impedance, and this unique setting automatically provides the lowest network Q possible. Low Q means low circulating currents, hence low loss, and it also provides the widest frequency bandwidth of operation before retuning is necessary. Finally, since the inductor is always parallel, the network always provides a two-pole lowpass response to provide harmonic rejection.

There are, however, some disadvantages which have prevented wider use of the "L" network in the past. First, to match all possible antenna loads, two configurations are required. One, for impedances greater than 50 ohms, requires the capacitor to be across the antenna. The other requires the capacitor to be placed across the transmitter when the antenna impedance is less than 50 ohms. This function is performed by switch S1. At high frequencies, as the load impedance approaches 50 ohms, i.e. the antenna has a fairly low SWR already, the values of L and C in the network required for a perfect match become very small — smaller than the stray or minimum values of the components used. To circumvent this problem, a small fixed compensating capacitor or inductor is placed into the circuit depending on whether the network is configured for high or low impedance respectively (HI or LO on switch S1). At low frequencies, the value of network capacity needed to match some loads is quite large, requiring a large and

expensive capacitor. To provide for this, fixed capacitors are placed in parallel with the variable capacitor to obtain the value needed. This function is also performed by switch S1; further rotation from the center position increases the value of capacitance in the circuit. (See FIGURE 3-1).

The 80859 SWR BOARD contains the SWR bridge circuit. Transformer T20 samples the incoming rf and feeds the balanced signals to detector diodes D20 and D21. The balance of the transformer bridge circuit is adjusted by trimmer C27 for a null. The dc voltages, filtered by C24, C26 and C23, C25 are fed to the meter circuits via a three pin connector.

The 80911 SWITCH BOARD contains three latching push-button switches used to select the metering functions. S3A selects either FWD or REV output lines coming from the rf bridge diodes. Switch S3B is used to select either the 2KW or 200W power calibration circuits. R30 is used to calibrate the 200 watt position and R31 provides calibration in the 2KW position. S3C is used to select either PWR or SWR signals for the meter. When placed in the SWR position, the SWR SET control, R27, determines the signal level sent from the bridge diodes to the meter.

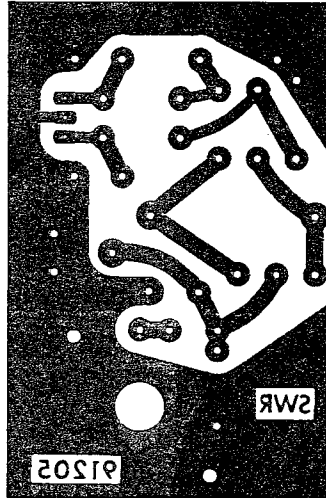

FIGURE 3-2. 80859 SWR BOARD CIRCUIT TRACE

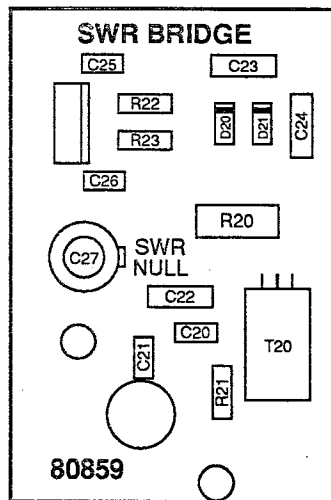

FIGURE 3-3. 80859 SWR BOARD COMPONENT LAYOUT

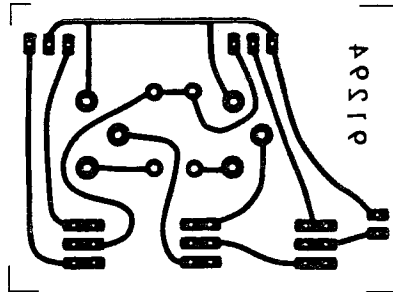

FIGURE 3-4. 80911 SWITCH BOARD CIRCUIT TRACE

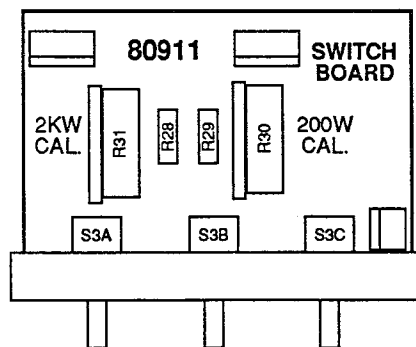

FIGURE 3-5. 80911 SWITCH BOARD COMPONENT LAYOUT

3-5 TUNER CONFIGURATIONS The following diagrams show the possible configurations of L and C used in the Model 238

Antenna Tuner. These combinations are selected by switch S1 (Refer also to FIGURE 3-1).

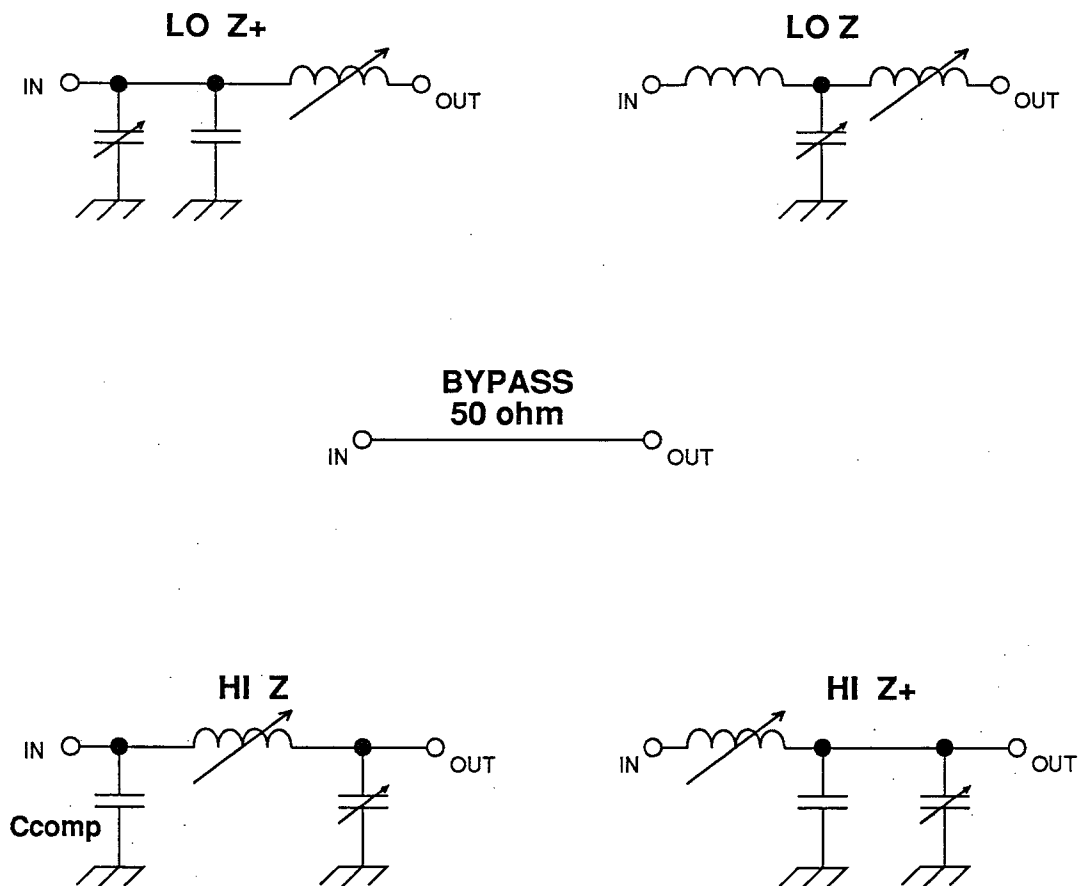

FIGURE 3-6. MODEL 238 TUNER CONFIGURATION DIAGRAMS

Ten-Tec, Inc.
1185 Dolly Parton Parkway
Sevierville, TN 37862
Repair Service: (865) 428-0364

LIMITED WARRANTY AND SERVICE POLICY, U.S.A. AND CANADA

Ten-Tec, Inc., warrants this product to be free from defects in material and workmanship for a period of one (1) year from the date of purchase, under these conditions:

1. **THIS WARRANTY APPLIES ONLY TO THE ORIGINAL OWNER.** It is important that the warranty registration card be sent to us promptly.
2. **READ THE MANUAL THOROUGHLY.** This warranty does not cover damage resulting from improper operation. Developing a thorough understanding of this equipment is your responsibility.
3. **IF TROUBLE DEVELOPS** we recommend you contact our customer service group direct at the address or phone number shown above. It has been our experience that factory direct service is expeditious and usually results in less down-time on the equipment. Some overseas dealers do offer warranty service and, of course, have our complete support.
4. **EQUIPMENT RETURNED TO THE FACTORY** must be properly packaged, preferably in the original shipping carton(s). You pay the freight to us and we prepay surface freight back to you. Canadian customers must have proper customs documentation sent with incoming repair equipment. Duties or fees charged due to improper documenting are the responsibility of the owner of the equipment.
5. **EXCLUSIONS.** This warranty does not cover damage resulting from misuse, lightning, excess voltages, polarity errors or damage resulting from modifications not recommended or approved by Ten-Tec. In the event of transportation damage, a claim must be filed with the carrier. Under no circumstances is Ten-Tec liable for consequential damages to persons or property caused by the use of this equipment.
6. **TEN-TEC RESERVES** the right to make design changes without any obligation to modify equipment previously manufactured, or to notify owners of changes to existing equipment.
7. **THIS WARRANTY** is given in lieu of any other warranty, expressed or implied.

SERVICE OUTSIDE OF THE U.S.A. OR CANADA

Many of our international dealers provide warranty service on the equipment they sell. Many of them also provide out of warranty service on all equipment whether they sold it or not. If your dealer does not provide service or is not conveniently located, follow the procedure outlined above. Equipment returned to us will be given the same attention as domestic customers but roundtrip freight expense, customs and broker fees will be paid by you.

Part no. 74244