



# 575M-6

## TRANSISTORIZED MICROPHONE WITH EXTERNAL TONE AND VOLUME CONTROLS

### Description

The Astatic 575M-6 "power" microphone offers the CB'er modern "teardrop" styling and features along with the sound and "talk-power" made famous by the Astatic D104 for over 60 years.

An output impedance compatible with the inputs of almost all commercial transceivers and externally adjustable high gain amplifier ensures desired modulation level. The 575M-6 has easily accessible slide controls for volume and tone adjustment so that the correct modulation level and tone quality can be set for each operators voice. The 575M-6 preamplifier is powered by a readily available, easily replaced, 9 volt battery. The 575M-6 has a six wire coil cord which allows for relay, electronic or virtually any type hookup with almost any transceiver. The audio line is open during receive.

### Specifications

- Type: ..... Transistorized Ceramic
- Frequency Response: ..... Adjustable (See Fig. 1)
- Maximum Output Level: ... -38 dB below 1 volt per microbar at 1 KHz into 1 megohm load
- Output Adjustment: ..... 40 dB minimum range
- Impedance: ..... 5000 ohms max., recommended load of 100 ohms and up; performs well over entire impedance range up to open circuit
- Cable: ..... Five conductor (one conductor shielded) coiled cord that extends to 2.3 m (7 1/2 ft.). Durable strain relief bushing protects against cable breakage at microphone housing.
- Housing: ..... Attractive, durable high impact molded black ABS
- Battery: ..... Standard 9 Volt Battery (Not Included)
- Battery Life: ..... Approximately 6 months (based on normal usage)
- Size: ..... 100 mm (3 15/16") high x 75.4 mm (2 31/32") wide x 54.8 mm (2 5/32") deep
- Weight: ..... 227 grams (8 oz.)



### ASTATIC Quality

All 575M-6 microphones are audio tested and inspected prior to shipment. Our absolute commitment to quality insures that Astatic microphones remain the **Best Value** in today's competitive industry.

CUT HERE

#### WARRANTY (LIMITED)

Astatic Radio Communication Microphones are warranted for one year from the date of purchase by CTI Audio, Inc. to be free from defects in material and workmanship. In event of such defect, product will be repaired or replaced at our option with a new unit of equal or superior value. This will be at no charge if delivered prepaid to CTI Audio, Inc. or an authorized service center, together with the sales slip or other proof of purchase. The unit will be returned prepaid. Warranty excludes exterior finish, appearance items, or malfunction due to abuse or operation under other than specified conditions. Consequential or incidental damages are excluded.

#### SHIPPING INSTRUCTIONS

Carefully repack the unit and return it prepaid to:

CTI Audio, Inc. (Attention: Service Dept.)  
Harbor & Jackson Streets, Conneaut, Ohio 44030

If outside the United States, contact your dealer or distributor for warranty details.

#### PURCHASE REGISTRATION



DATE PURCHASED \_\_\_\_\_ MODEL \_\_\_\_\_

\* PLEASE COMPLETE AND RETURN WITHIN 10 DAYS TO CTI AUDIO, INC., P.O. BOX 120 CONNEAUT, OH 44030 \*

NAME \_\_\_\_\_ ADDRESS \_\_\_\_\_

CITY \_\_\_\_\_ STATE \_\_\_\_\_ ZIP \_\_\_\_\_ PHONE NUMBER \_\_\_\_\_

PURCHASED FROM \_\_\_\_\_ ADDRESS \_\_\_\_\_

CITY \_\_\_\_\_ STATE \_\_\_\_\_ ZIP \_\_\_\_\_ PHONE NUMBER \_\_\_\_\_

APPLICATION WHERE MICROPHONE IS USED:

C.B.  AMATEUR RADIO  LAND MOBILE, MARINE, BUSINESS RADIO  OTHER

COMMENTS: (May we reprint your comments:  YES  NO)

# SPECIFICATIONS FOR 575M-6

downloaded by  
Amateur Radio Directory  
www.hamdirectory.info

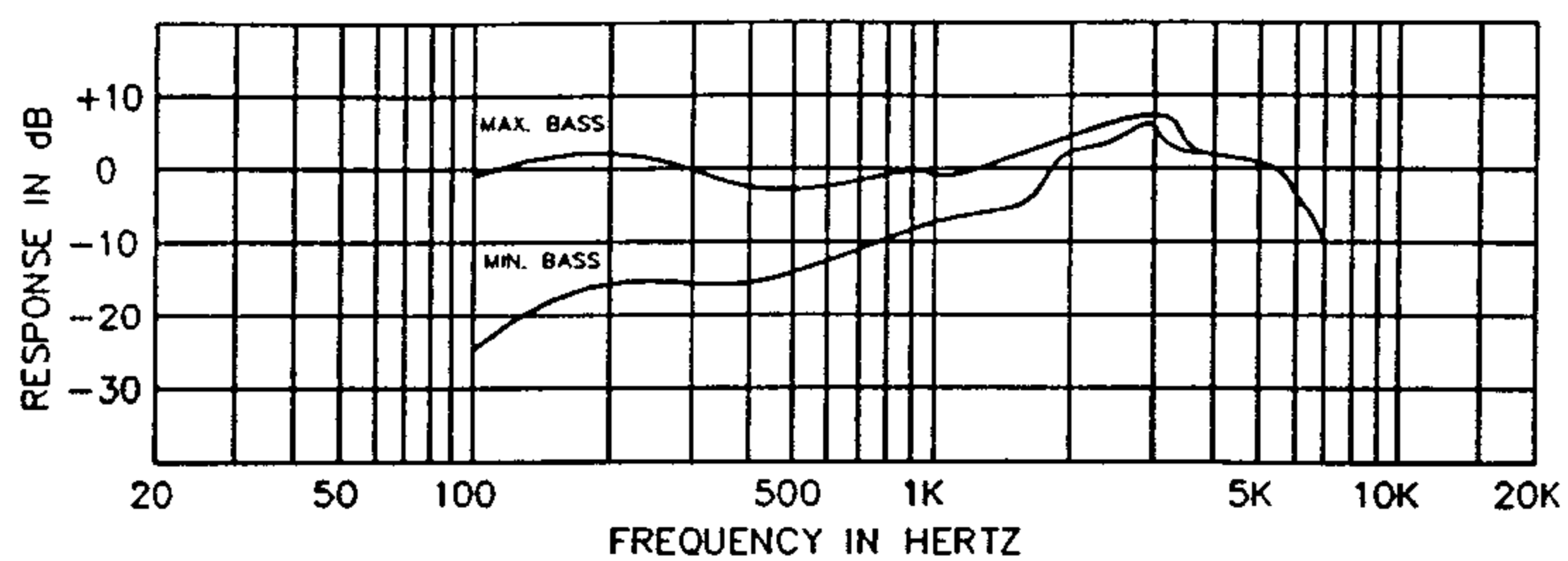
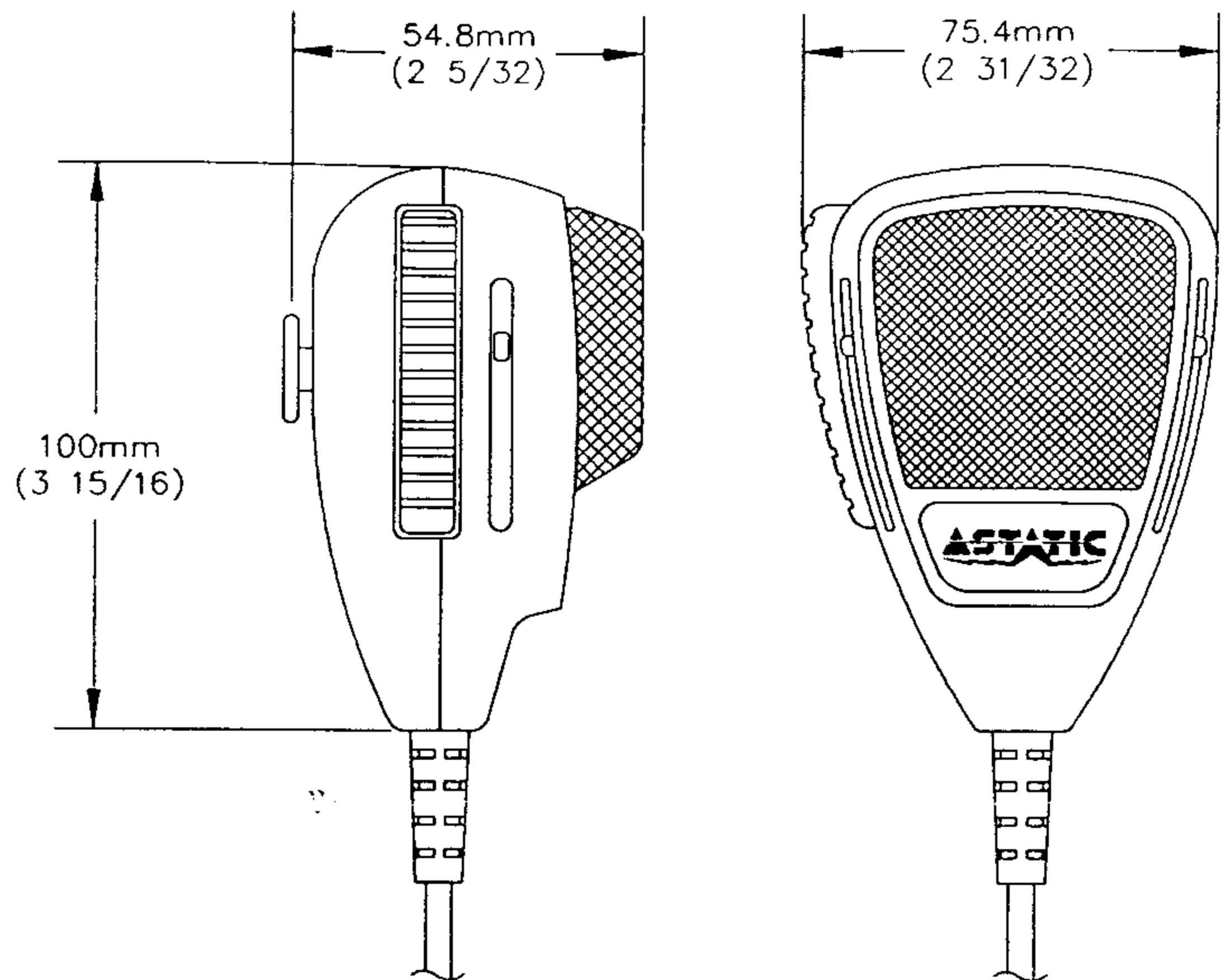

## Battery Replacement

Remove the rear housing by removing the four screws. Carefully lift off the rear housing. Unsnap the battery from the battery connector and install a new battery. Carefully replace the rear housing and fasten with the four screws previously removed. Depress the switch lever fully while tightening the screws.

## Volume and Tone Adjustments

At a speaking distance of approximately 2 inches (or the position you prefer) with the external volume control set at 0 and the tone control set in the center position, adjust the volume control for the correct modulation level. Sliding the volume control toward 9 increases the volume. The external tone control should then be adjusted for the most intelligible sound. Slide the tone control toward 0 for an increase in bass response and towards 9 for a decrease in bass response.

## Connector-Cable Clamping

If the microphone plug you have selected for your hookup requirements does not have a cable clamp suitable for this small diameter high quality microphone cable, use tubing as supplied by ASTATIC. Simply slip tubing over cable prior to soldering of lead wires. Position it to ensure proper clamping of cable and tubing by the connector.

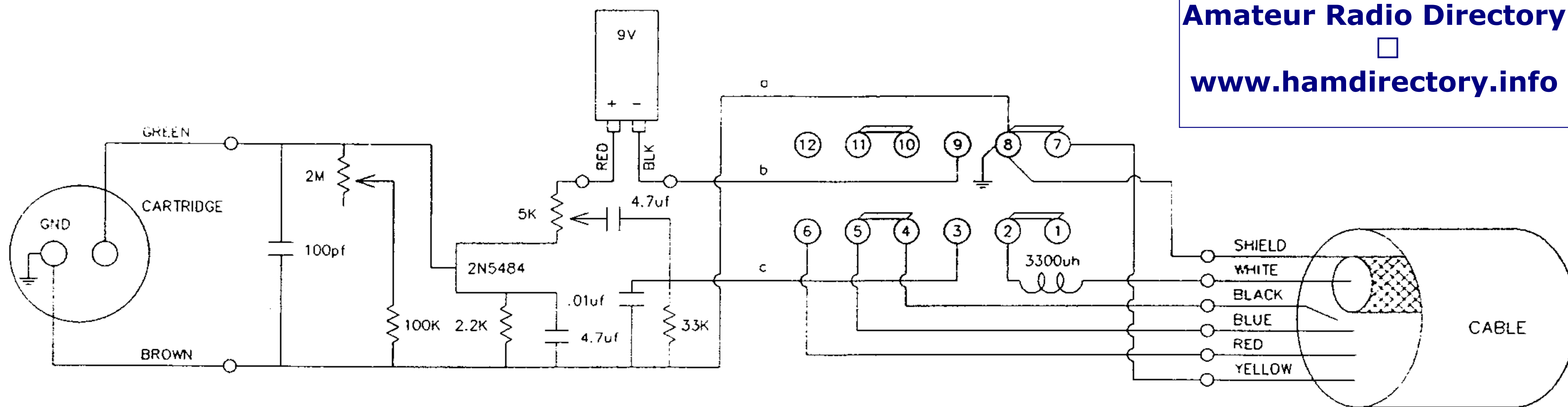

Downloaded by  
Amateur Radio Directory  
www.hamdirectory.info

CUT HERE

PLACE IN ENVELOPE AND RETURN TO:

CTI AUDIO, INC.  
341 HARBOR STREET  
CONNEAUT, OHIO 44030-0120

CUT  
HERE

**1**  
**YEAR**  
**LIMITED**  
**WARRANTY**