

**NOISE-CANCELING HAND-HELD DYNAMIC MICROPHONES**



**GENERAL**

The Shure 577 Series of SONOBAR® microphones are designed for clear, crisp, natural voice reproduction combined with a highly effective noise-canceling function. The microphones are high-quality, extremely reliable, hand-held dynamic units, and feature professional design, small size, light weight, and modular construction.

The 577 Series noise-canceling microphones are the result of extensive research, and represent a significant improvement over most microphones having anti-noise features. Noise cancellation in the 577 Series Microphones is obtained through the combination of highly directional operation, and superior discrimination against noise or unwanted sounds from a relatively distant source and over an unusually wide frequency range.

The modular construction of the 577 Series greatly facilitates field servicing. The cartridge, switch and cable are of modular design, which makes them replaceable in a matter of minutes if servicing is ever necessary.

The 577 Series microphones fit naturally and comfortably in the hand, and are not affected by heat or humidity. The exclusive ARMO-DUR® case is immune to oil, grease, fumes, salt spray, sun, rust and corrosion—and is outstanding in its ability to withstand mechanical shocks and vibration. The "million-cycle" leaf-type switch is designed to withstand severe operating conditions and constant usage.

**Microphone Features:**

- Highly intelligible voice response
- Extremely effective noise cancellation
- Highly rugged and reliable dynamic transducer
- Modular construction for ease of field service
- "Million-cycle" leaf-type switch controls microphone and external relay or switching circuit
- Super-rugged ARMO-DUR® case
- Lifetime hang-up button and mounting bracket
- Triple-Flex® cable provides three to four times the flex life of previously available coiled cords

**APPLICATIONS**

The 577 Series microphones are designed for use in communications and paging applications where their qualities of highly intelligible voice response, noise canceling, and ruggedness are a necessity. Such applications are two-way and industrial communications systems, including radiotelephone and amateur radio. The 577 Series can be used with great effectiveness in all types of mobile communications, including such difficult environments as helicopter traffic and news reports. The microphones are exceptionally suitable for outdoor and indoor public address and paging systems in noisy areas such as factories, airport terminals, lobbies and restaurants.

The Model 577A is a high-impedance dynamic microphone with a high output level. It is designed for direct connection to high-impedance microphone inputs in installations where a cable length of 15m (50 ft) or less is needed.

The Model 577B is a balanced-line low-impedance dynamic microphone. It is designed for direct connection to low-impedance microphone inputs and/or for installations where long cable lengths are needed. Shure Model A95 Series Line Matching Transformers are available for use when a low-impedance microphone or long cable is desired but the associated input is high impedance. The transformers are supplied with a variety of input and output connectors.

**ACOUSTIC CONSIDERATIONS**

The important characteristics contributing to total noise reduction in the 577 Series microphones are shaped frequency response, directionality, and distance discrimination. The acoustical elements are arranged to optimize performance in the frequency range of 100 to 5,000 Hz. The result is the elimination of sounds outside the desired frequency range and proper control of those sounds within the desired range.

The 577 microphones reject noise through their inherent directional properties and discriminate against unwanted sounds arriving from a distance in favor of sounds from a near source. The microphones operate on the pressure-gradient principle and have two sound entry ports, spaced a small distance apart.

In order to obtain the best performance with these microphones, they must be used as "close-talking." The lips should be as close to the microphone grille as possible (pressed against the rubber lip guard), with a distance of up to 25 mm (1 in.) from the grille providing the greatest discrimination between voice sounds and background noise.

**INSTALLATION AND CONNECTIONS**

A mounting bracket is supplied with each microphone (see Figure 1) to provide a snap-in hang-up for the microphone when not in use.

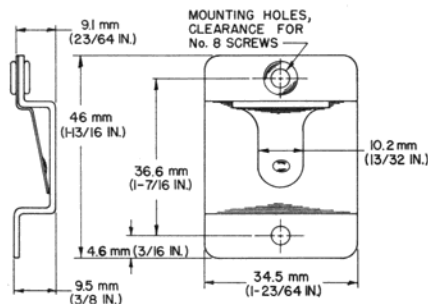

**FIGURE 1**

The internal switch connections of Models 577A and 577B are shown in Figure 2.

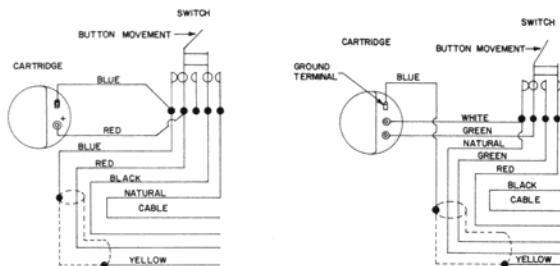

**MODEL 577A**

**MODEL 577B**

**INTERNAL CONNECTIONS**  
**FIGURE 2**

The Model 577A is a high-impedance microphone with a three-conductor coiled-cord cable (one conductor shielded) and a double-pole single-throw leaf-type switch to control the microphone circuit and an external relay or switching circuit. The RED lead is the "hot" conductor for connection to the microphone circuit; the shield is connected to the microphone circuit ground. The NATURAL and BLACK leads control the relay or switching circuit. The microphone circuit of the switch is normally shorted but may be easily modified for normally open operation.

The Model 577B is a low-impedance microphone with a four-conductor (two conductors shielded) coil-cord cable and a double-pole, single-throw, leaf-type switch to control the microphone circuit and an external relay or switching circuit. The NATURAL and GREEN leads are the "hot" conductors for balanced-line connection to the microphone circuit; the shield is connected to the microphone circuit ground. The RED and BLACK leads control the relay or switching circuit. The microphone circuit of the switch is normally open but may be easily modified for normally shorted operation.

**Model 577A Circuit Modification:** The microphone circuit of the 577A is shorted when the microphone switch button is in the normal position. The microphone section of the switch has an extra leaf which may be used to provide a normally open microphone circuit:

1. Remove the three No. 6 Phillips self-threading screws from the back of the microphone case.
2. Separate the case front and back, and remove the switch button.
3. Unsolder or clip the RED cable lead from the lower switch solder lug (see Figure 2). NOTE: RED cartridge lead remains connected to solder lug.
4. Solder the RED cable lead to the upper unused switch solder lug.

NOTE: In certain instances where the switch sequence is critical, it may be necessary to remove the effect of the shorted switch on the cartridge. This is done by insulating the switch blade with the BLUE leads from the switch blade with the RED lead. Slide a piece of insulating tubing over or affix a piece of insulating tape to the switch blade.

5. Replace the switch button in the case front. Place the case halves together and fasten them with the No. 6 screws previously removed.

**Model 577B Circuit Modification:** The microphone circuit of the 577B is open when the microphone switch button is in the normal position. The microphone may be modified to provide a normally shorted microphone circuit as follows:

1. Remove the three No. 6 Phillips self-threading screws from the back of the microphone case.
2. Separate the case front and back, and remove the switch button.
3. Unsolder or clip the GREEN cable lead from its switch solder lug.
4. Solder the GREEN cable lead to the switch solder lug containing the GREEN cartridge lead.
5. Replace the switch button in the case front. Place the case halves together and fasten them with the No. 6 screws previously removed.

#### OPERATION

No special precautions beyond ordinary care are necessary in operating the 577 microphones. They will operate very satisfactorily under most conditions of humidity and temperature. Dropping the microphones or other severe mechanical shocks should be avoided.

### SPECIFICATIONS

#### Type

Dynamic, Noise-Canceling

#### Frequency Response

100 to 5,000 Hz (see Figure 3)

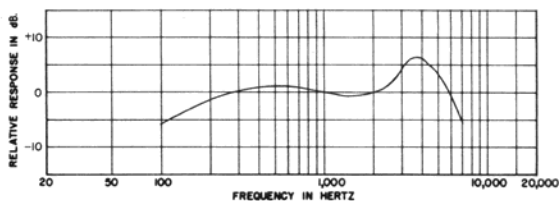

TYPICAL FREQUENCY RESPONSE  
FIGURE 3

#### Impedance

Model 577A: Microphone impedance is "High" for connection to high-impedance microphone inputs.

Model 577B: Microphone rating impedance is 150 ohms (175 ohms actual) for connection to microphone inputs rated at 19 to 300 ohms.

#### Output Level (at 1,000 Hz, 5/16 in.)

	577A	577B
Open Circuit Voltage*	-23.5 dB	-46.0 dB
Power Level**		-64.5 dB

\*0 dB = 1 volt per 100 microbars

\*\*0 dB = 1 milliwatt per 10 microbars

#### Hum Sensitivity

Model 577A: Equivalent to 44 dB SPL in 1 millioersted field

Model 577B: Equivalent to 32 dB SPL in 1 millioersted field

#### Operating Temperature Range

-54° to 85°C (-65° to 185°F)

#### Switch

Double-pole, single-throw, leaf-type, push-to-talk

#### Cable

Non-detachable, 1.8m (6 ft), neoprene-jacketed coil cord.

Model 577A: three-conductor (one conductor shielded).

Model 577B: four-conductor (two conductors shielded).

#### Case

Two-tone gray, high-impact ARMO-DUR®

#### Dimensions

See Figure 4

