



Digital Voice Modem  
**ARD9000MK2**  
Instruction Manual



**AOR, LTD.**

*Authority On Radio  
Communications*

Thank you for purchasing the AOR **ARD9000MK2** Digital Voice Modem.

All over the world, amateur radio operators have been discovering how much fun it is to work HF without background noise.

AOR set the pace in this breakthrough technology with its ARD9800. In response to worldwide demand, AOR had developed the **ARD9000** which makes digital voice communications even more affordable. Now, we have developed the new **ARD9000MK2**.

AOR's digital voice technology delivers audio quality you have to hear to believe. Whether you are working digital voice across state lines or across an ocean, amazing doesn't seem strong enough to describe it.

With an **ARD9000MK2**, it's easy to convert existing HF analog transceivers to work digital voice with NO transceiver modifications. The **ARD9000MK2** automatically detects a digital signal and decodes it, so you also maintain full analog capabilities. Whether a contact comes in as digital or analog, the **ARD9000MK2** can handle it. Digital voice could be the biggest revolution in HF radio since SSB!

Please read through this instruction manual and familiarize yourself with the operation of the **ARD9000MK2**. We suggest you keep this instruction manual for future reference.

We believe you will enjoy using the **ARD9000MK2** as an enhancement to your enjoyment of amateur radio.

AOR, LTD.

## Features:

- **No transceiver modifications needed.**

The ARD9000MK2 uses the same audio frequencies (300Hz~2500Hz) as microphone audio to modulate the voice signal. This allows you to use an analog radio as a digital voice radio.

- **Works on Single Side Band (SSB) mode.**

The Automatic frequency clarifier function adjusts frequency drift automatically in the SSB mode. (Approximately up to +/- 125Hz). Utilizes the OFDM (Multi Carrier Modulation) circuit that is effective against Multi-path or Selective Fading.

- **Automatic digital receive**

Automatic voice signal detector recognizes the received signal as analog or digital, quickly switching to the appropriate mode.

- **Built-in high grade Vocoder (AMBE)**

Utilizing high-grade digital voice compression delivers quality digital voice communications.

- **Built-in FEC error correction**

A powerful error correction circuit delivers stable and reliable communications.

- **Small and compact unit. Easy to operate.**

Simply connect the ARD9000MK2 between the microphone jack and microphone. No complicated modifications necessary. Optional interface cables for most popular transceivers are available or you can build your own connectors.

- **Wide range of operation voltages**

Operates on 11 to 16V DC from an external power source.

- **Utilizes a uniquely designed high performance DSP engine.**

- **Uses established G4GUO open protocol.**

The use of an open digital protocol means use of the ARD9000MK2 is permitted on US Amateur Radio Bands (non-USA users should check applicable regulations.)

## ARD9000MK2 vs. ARD9800

You may already be familiar with our ARD9800 Multi-Mode and Digital Voice Interface. The main difference between the ARD9000MK2 and the ARD9800 is that the ARD9000MK2 is a VOICE ONLY modem. However, both models are fully compatible for voice use.

**Caution: Signal conditions vary greatly, as such; no warranty can be made on how the ARD9000MK2 will perform in every circumstance.**

## **Information to the Digital Device user required by the FCC**

This equipment has been tested and found to comply with the limits for a Class B digital device, pursuant to Part 15 of the FCC Rules. These limits are designed to provide reasonable protection against harmful interference in a residential installation.

This equipment generates, uses and can generate radio frequency energy and, if not installed and used in accordance with the instructions, may cause harmful interference to radio communications. If this equipment does cause harmful interference to radio or television reception, which can be determined by turning the equipment off and on, the user is encouraged to try to correct interference by one or more of the following measures:

- Reorient or relocate the receiving antenna.
- Increase the separation between the equipment and receiver.
- Connect the equipment to an outlet on a circuit different from that to which the receiver is connected.
- Consult the dealer for technical assistance.

## **Precautions**

To prevent fire, personal injury, or unit damage, please observe the following precautions:

- Do not attempt to adjust this unit unless instructed to do so by this manual.
- Do not expose the unit to direct sunlight or place the unit close to heating appliances.
- Do not place the unit in excessively dusty, humid or wet areas.
- AOR is not responsible for any damages to the radio equipment due to improper settings or interface.
- AOR is not responsible for any loss of communications due to an unexpected change in propagation or the operating environment.

# Table of Contents

	Page
<b>Supplied &amp; optional accessories</b> -----	5
Magnetic mount -----	5
<b>Controls and functions</b> -----	6
<b>Front panel</b> -----	6
Microphone connector -----	6
Overload indicator -----	6
Status LED -----	7
Mode switch -----	7
Synchronization switch -----	8
Speaker volume adjustment with the switch -----	8
<b>Rear panel</b> -----	8
DC IN connector -----	8
Speaker OUT connector -----	9
Speaker IN connector -----	9
Radio connector -----	9
<b>Initial setting</b> -----	10
Microphone level -----	10
Output level to radio -----	10
Input level from radio -----	11
<b>Installation</b> -----	12
Connection of the speaker-microphone -----	12
Connection to the radio (for microphone input) -----	13
(for speaker input) -----	13
(for external speaker) -----	13
Connection to a power supply -----	13
<b>Operation</b> -----	14
Operating hints -----	14
Duty cycle -----	14
Operating frequencies -----	15
<b>Specifications</b> -----	15
<b>Limited Warranty</b> -----	16

## Supplied Accessories

The following items are provided in the package:

<u>Accessory</u>	<u>Quantity</u>
Speaker Microphone	1
Speaker Cable	1
DC Power cable	1
8 pin metal plug (for radio output)	1
Instruction manual (this booklet)	1
Magnetic mount base (CR25) with screw (M3)	1

## Optional Accessories

A pre-wired microphone interface cable for most popular transceivers

- D-6MY** for YAESU® transceiver with 6 pin modular microphone connector
- D-8MY** for YAESU® transceiver with 8 pin modular microphone connector
- D-8MI** for ICOM® transceiver with 8 pin modular microphone connector
- D-8MK** for KENWOOD® transceiver with 8 pin modular microphone connector
- M-8MY** for YAESU® transceiver with 8 pin metal microphone connector
- M-8MI** for ICOM® transceiver with 8 pin metal microphone connector
- M-8MK** for KENWOOD® transceiver with 8 pin metal microphone connector

## Magnetic mount

The supplied magnetic mount base holds the ARD9000MK2 in place against a metal surface. Simply screw it to the bottom panel's center hole.

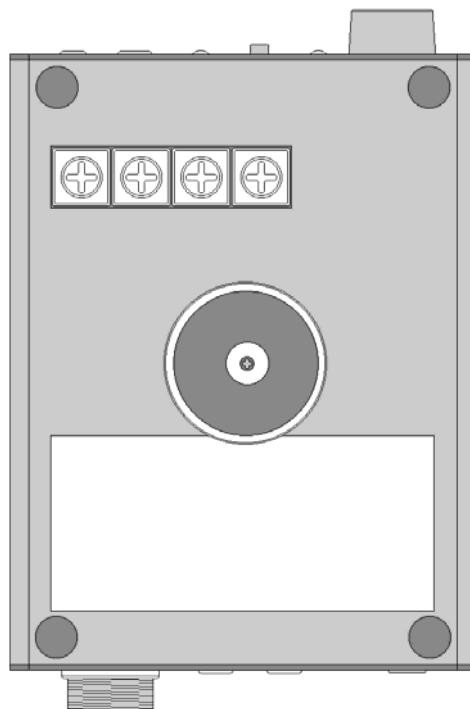

# Controls and Functions

## Front Panel

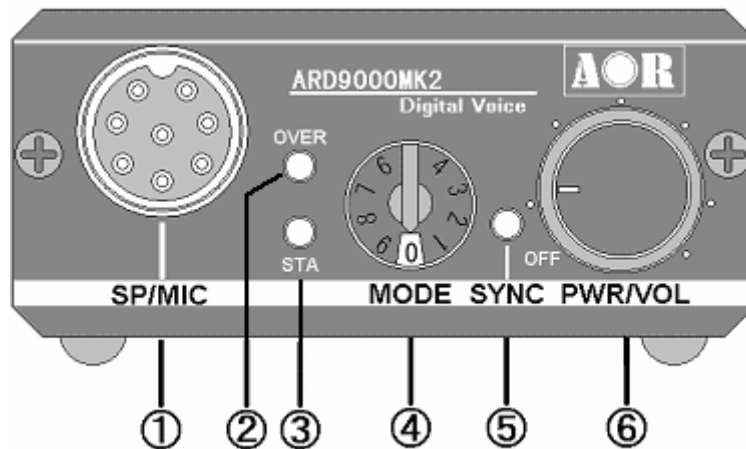

### (1) Microphone Connector (SP/MIC)

Connect the supplied speaker-microphone to this connector. Speaker audio is provided by the speaker-microphone.

If you wish to use your own microphone rather than the supplied speaker-microphone, you may rewire your microphone cable.

However, you will need to use your own external speaker connecting to the SP OUT of the rear panel of the ARD9000MK2 as it does not have a built-in internal speaker.

Below is a pin assignment of the speaker-microphone connector of the ARD9000MK2.

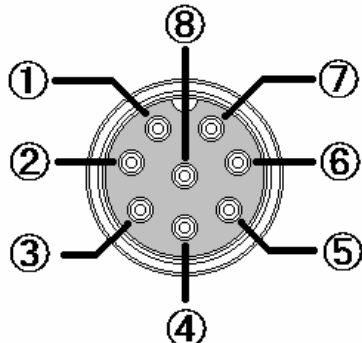
	<u>Pin #</u>	<u>Signal</u>	<u>Details</u>
	1	Speaker output	Speaker output
	2	BIAS	5V DC though 2.2 Kohm
	3	GND	Chassis ground
	4	NC	No connection
	5	NC	No connection
	6	MIC PTT	PTT (Push To Talk) input
	7	MIC GND	Microphone ground
	8	MIC IN	Microphone signal input

### (2) Overload indicator (OVER)

#### 1) Microphone level (in transmit mode)

Lit when the microphone input is overloaded.

A proper microphone input level will light the LED from time to time

when speaking into the microphone at a normal voice level. The microphone level can be changed by adjusting the microphone level controller.

*Refer to the Presetting - Microphone Level chapter for details.*

**2) Input level (in receive mode)**

To set the optimum level of audio from the transceiver (crucial for good decoding of digital signals), this LED operates as an input level indicator in receive mode, as follows:

<i>LED flashing</i>	<i>Input level too low</i>
<i>LED off</i>	<i>Input level optimal</i>
<i>LED always on</i>	<i>Input level too high</i>

**(3) Status LED (STA)**

<b>SITUATION</b>	<b>LED color</b>
Analog standby	Off
Digital standby	Green
Analog transmit	Red
Digital transmit	Orange
Digital receive	Green blinking

**(4) Mode Switch (MODE)**

There are 10 modes to choose from, as follows:

<b>Position</b>	<b>Mode</b>	<b>Header</b>	<b>Analog/digital switch</b>	
0	SSB	1.6 sec	PTT->A	
1	SSB	1.4 sec.	PTT->A	
2	SSB	1 sec.	PTT->A	
3	SSB	1.6 sec.	PTT->B	
4	SSB	1.4 sec.	PTT->B	
5	SSB	1 sec.	PTT->B	
6	FM (*)	1 sec.	PTT->B	Voice squelch
7	FM (*)	1 sec	PTT->B	All digital
8	FM (*)	0.5 sec	PTT->B	Voice squelch
9	FM (*)	0.5 sec	PTT->B	All digital

**Remarks:**

**Header** stands for the header tone length. The ARD9000MK2 synchronizes on the header tones at the initial contact with other users.

**PTT->A** allows user to toggle between analog and digital transmission just by quickly pushing the PTT button. The second press opens the microphone and allows you to talk.



**PTT->B** Pushing the PTT button half way through toggles the analog/digital mode, continue and fully press the PTT to open the microphone and talk.

**Voice squelch:** Allows you to hear both analog and digital transmissions.

**All digital:** The only audio you will hear is when the ARD9000MK2 detects and decodes a digital transmission.

(\*): In FM mode, the ARD9000MK2 operates best when your transceiver squelch is fully open.

### **(5) Synchronization switch (SYNC)**

Enables the re-synchronization of digital reception if synchronization is lost during a communication session.

### **(6) Speaker volume adjustment with the switch (PWR/VOL)**

Adjustment for speaker output level of the speaker-microphone, as well as for the speaker output on the rear panel. Turning the knob fully counterclockwise switches the unit off.

## **Rear Panel**

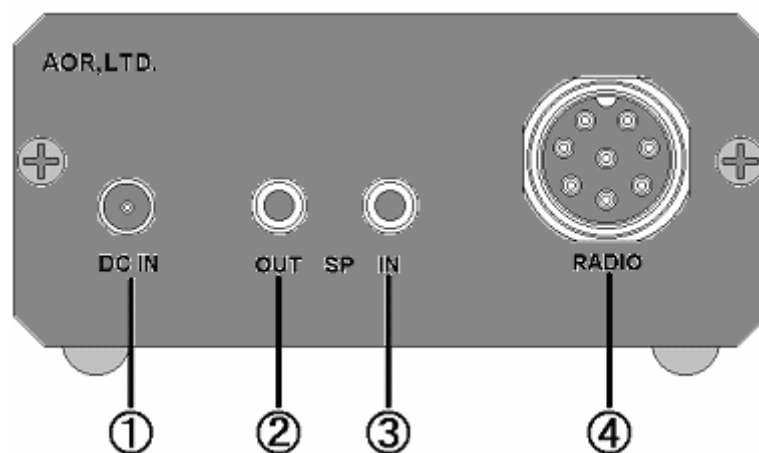

### **(1) DC IN Connector (EIAJ Type 4)**

Using the supplied DC power cable, connect to a regulated power supply (11~16V DC).

**We strongly recommend that you use a separate power supply for the ARD9000MK2.**

<u>Color</u>	<u>Polarity</u>
RED	Positive (+)
BLACK	Negative (-)

## **(2) SPEAKER OUT Connector (3.5 mm mono jack)**

If you wish to use your own external speaker, connect it to this jack. Once connected, the speaker-microphone's audio is disabled.

## **(3) SPEAKER IN Connector (3.5 mm mono jack)**

Connect to the transceiver's speaker output with the supplied cable. (Input level: 0.5V – 5V p-p, input impedance: 8 Ohms)  
Do not connect other audio sources like your radio's ACC-connector or LINE-OUT as those audio levels are insufficient to drive the ARD9000MK2.

## **(4) RADIO Connector (RADIO)**

Using the supplied 8-pin connector, connect the ARD9000MK2 to your transceiver's microphone input.  
The optional pre-wired microphone cable is available from AOR for your transceiver or you will need to prepare your own microphone connector and cable for your transceiver.

Wire a shielded microphone cable according to the microphone connector specifications of your radio (refer to your radio operator's manual).

Below are the pin assignments of the RADIO connector.

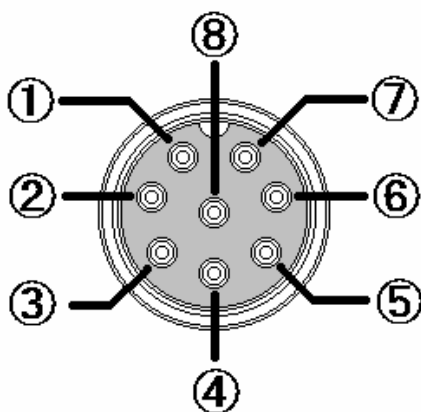

<u>Pin #</u>	<u>Signal</u>	<u>Details</u>
1	MIC GND	Microphone ground
2	MIC OUT	Microphone Output
3	PTT	PTT output
4	PTT GND	PTT ground
5	NC	No connection
6	NC	No connection
7	GND	Ground
8	NC	No connection

**Note: MIC GND and GND must not be connected together in the ARD9000MK2 connector or RF feedback will result.**

**It is recommended that you connect a station ground wire to a screw on the rear panel.**

# Initial Setting

## Microphone Level

The microphone level has been properly adjusted at the factory with the provided speaker-microphone. Therefore, no further adjustment is needed for normal operation.

If you wish to use your own microphone rather than the one included, you will need to rewire your microphone cable to match the pins of the ARD9000MK2 and then adjust the microphone level as described in the following steps:

1. Connect your microphone to the Microphone connector on the ARD9000MK2.
2. Make sure that the input level pot “**MIC-IN**” located on the bottom side of the unit is set to factory default (**9 o’clock position**).
3. Press the PTT switch on your microphone and speak normally into the microphone.
4. The OVERLOAD LED is lit either red for analog, or orange for digital transmission (depending on your rotary switch position). Adjust the “**MIC-IN**” pot on the bottom side of the ARD9000MK2 by observing the OVERLOAD LED as follows:

<i>LED off</i>	<i>Input level too low</i>
<i>LED sometimes lit</i>	<i>Input level optimal</i>
<i>LED always on</i>	<i>Input level too high</i>

## Output Level to Radio

Before readjusting the output levels to the transceiver, be sure that the microphone level is correctly set first, as described above.

Although the factory setting should work with most transceivers, it is possible to readjust the audio output level manually, as described below. This level must be correctly set to enable effective operation with your transceiver.

The ARD9000MK2 allows you to apply separate settings for analog and digital transmissions.

1. Connect the supplied speaker-microphone to the ARD9000MK2 first, then connect your radio to the RADIO connector of the ARD9000MK2 by using your prepared connection cable. Now turn on the ARD9000MK2.
2. Make sure that the output level pot “**ANA-OUT**” or “**DIG-OUT**” located on the bottom side of the unit is set to factory default (**4 o’clock position for analog, 9 o’clock position for digital**).

3. Press the PTT switch on the supplied speaker-microphone and speak normally into the speaker-microphone.

In case the OVERLOAD LED is not lit, it means that the microphone's "**MIC-IN**" level has not been set properly. Refer to the previous "Microphone level" section to correct this level first.

4. Adjust microphone gain control on the radio transceiver to suitable level. It is recommended that you adjust the level so that the ALC function is activated. If the ALC function activates too much, it might create audio distortion and as a result, the communication link with the distant station may be broken.
5. Adjust the **output level pot** on the bottom side of the ARD9000MK2 when the microphone gain control on the radio transceiver does not adjust to provide a sufficient level.

### Input Level from Radio

Although the factory setting should work with most transceivers (**12 o'clock position**), it is possible to adjust the audio input level manually. This level must be correctly set to enable effective operation with your transceiver. If, and only if you are unable to achieve the correct level, then adjust the input level pot "**SP-IN**" on the bottom of the ARD9000MK2:

Apply adjustments by observing the OVERLOAD LED as follows:

<i>LED flashing</i>	<i>Input level too low</i>
<i>LED off</i>	<i>Input level optimal</i>
<i>LED always on</i>	<i>Input level too high</i>

# Installation

## Connection of the speaker-microphone

Connect the supplied speaker-microphone to the SP/MIC connector of the ARD9000MK2.

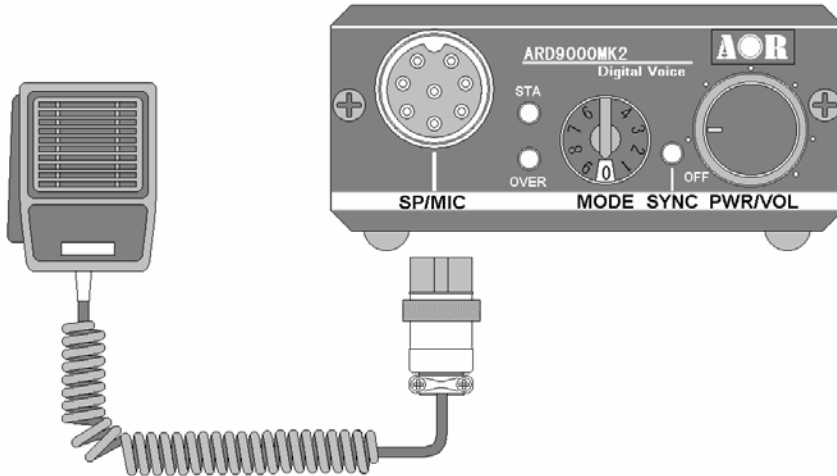

If you wish to use your own microphone or a speaker-microphone, please refer to the wiring diagram shown below.

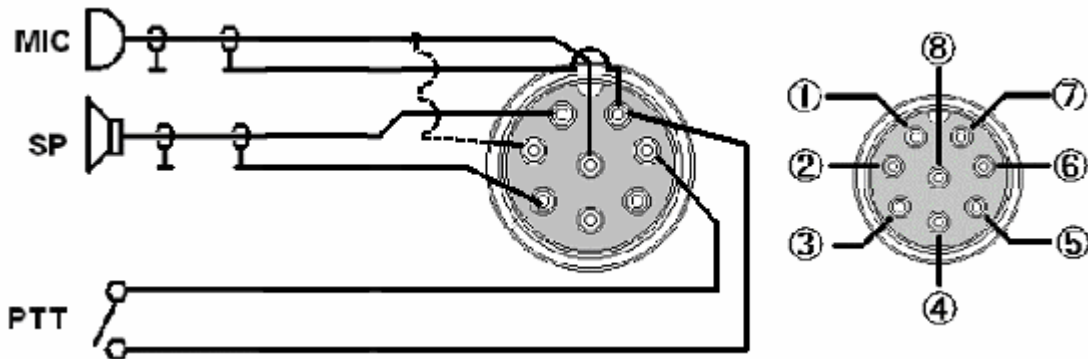

<u>Pin #</u>	<u>Signal</u>	<u>Details</u>
1	Speaker output	Speaker output
2	BIAS	5V DC though 2.2 Kohm
3	GND	Chassis ground
4	NC	No connection
5	NC	No connection
6	MIC PTT	PTT (Push To Talk) input
7	MIC GND	Microphone ground
8	MIC IN	Microphone signal input

**Connection to the radio (for microphone output)**

Connect the RADIO connector and the microphone connector of your transceiver with the prepared microphone interface cable. Please make sure you have the correct wiring to your transceiver as shown below.

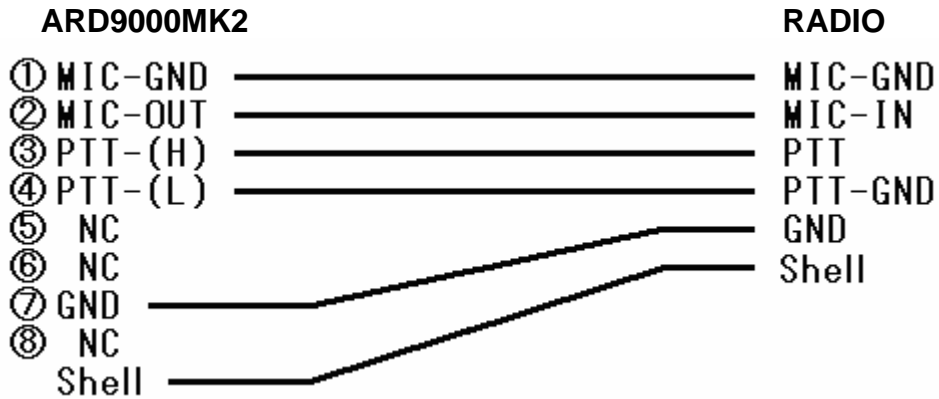

**Connection to the radio (for speaker input)**

Connect the **SP IN** located on the rear panel of the ARD9000MK2 to the speaker output (external speaker) of your transceiver with supplied speaker cable (with 3.5mm mono plug on each end).

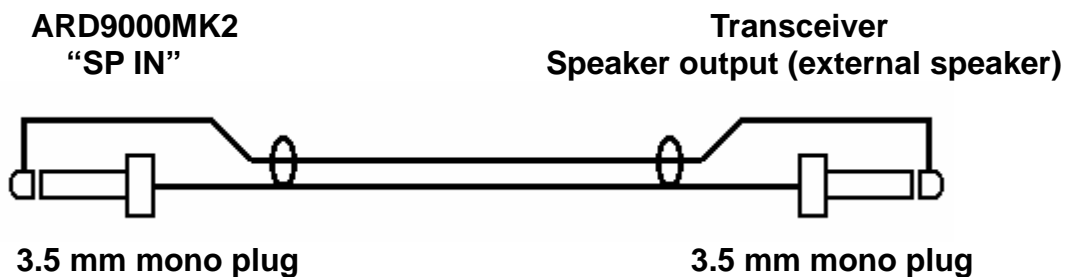

**Connection to the radio (for external speaker, optional)**

When you use your own external speaker, connect it to the **SP OUT** located on the rear panel of the ARD9000MK2 using a shielded cable.

**Connection to a power supply**

Using the supplied DC power cable, connect it to the regulated power supply.

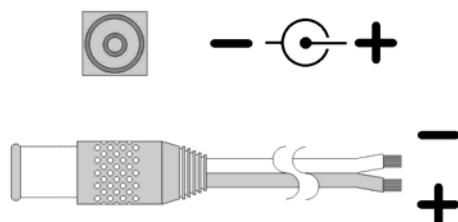

**We strongly recommend that you use a separate power supply for the ARD9000MK2.**

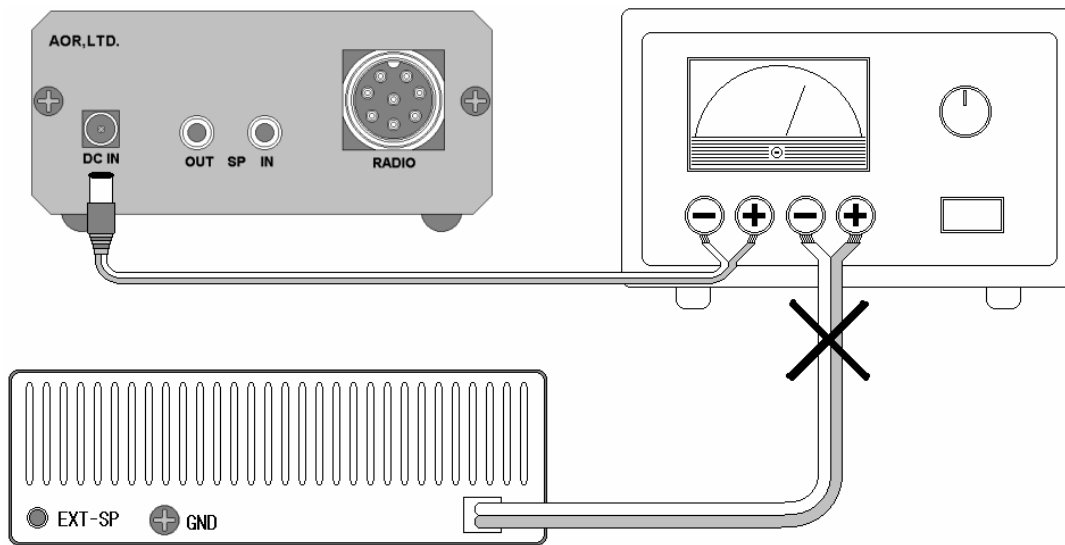

## Operation

After installation and all settings are completed, you are almost ready to operate your ARD9000MK2.

### Operating hints

1. Try to coordinate your frequencies as closely as possible. There is some small margin for error, but best results are obtained when both transceivers are exactly on the same frequency.
2. Be sure your IF filters are about 3KHz or wider.
3. Don't "overdrive" your ARD9000MK2 with too much audio from your transceiver.
4. Don't transmit using "compression" (also known as a speech processor).
5. Be sure your ALC is within its specified operating region. If in doubt, lower audio output seems to work better than a higher setting.
6. Be mindful of your bandwidth when selecting a frequency on which to transmit.
7. Be sure you will not interfere with operators on adjacent frequencies.

### DUTY CYCLE

The duty cycle of your transceiver will be more intense when transmitting in the digital mode. This is important to users of amplifiers.

Because the digital signal makes full use of the SSB audio bandwidth, you should consider that you will be transmitting at the maximum power output you have selected. At maximum power settings, this will likely result in your transmitter consuming more power and generating more heat.

## **OPERATING FREQUENCIES**

Below please find web sites that are NOT affiliated with AOR.  
AOR takes no responsibility for their content.

<http://www.standpipe.com/w2bri/fastmodem/fastmodem.htm>  
<http://www.rfelectronics.com/>  
<http://www.melwhitten.com/>

**Remember, to receive SSB transmissions, you need to set the ARD9000MK2 to SSB mode, and in FM mode to receive FM transmissions.**

The operation modes can be selected with the MODE SWITCH, and described in the chapter, "Controls and Functions".

## **Specifications**

ARD9000MK2 Specification	
Modulation method:	OFDM
Bandwidth:	300 Hz - 2500 Hz, 36 carriers
Symbol Rate:	20 mS (50 baud)
Guard interval:	4mS
Tone steps:	62.5 Hz
Modulation method:	36 carriers: DQPSK (3.6K)
AFC:	+/- 125 Hz
Error correction:	Golay + Hamming
Header:	0.5-2sec. 3 tones + BPSK training pattern for synchronization
Digital voice chip:	AMBE2020 encoder, decoder
Signal detection:	Automatic Digital detect, Automatic switching between analogue mode and digital mode
Power requirements:	10 ~ 16 V DC, Approximately 100 mA (@ 12 V DC)
Weight:	350g.
Dimensions (w, h, d):	70 (w) x 33 (h) x 98 (d) (mm) Projections excluded.
Connectors:	MIC/SP, Radio, DC-IN, SP-IN, SP-OUT.
Supplied access:	Speaker-microphone, DC cable, Speaker cable, 8-pin Radio connector, magnetic mount base with screw, instruction manual.
Options:	Pre-wired microphone interface cable for most popular transceivers

Specifications are subject to change without notice or obligation.



## **LIMITED WARRANTY**

AOR USA, Inc. (AOR) warrants its products as described below:

AOR will repair or exchange equipment as a result of defects in parts or workmanship for a period of one year from the date of original retail purchase from an authorized AOR dealer.

### **Exclusions**

The following items are not covered by the AOR limited warranty:

1. Products that are damaged through accident, abuse, misuse, neglect, or user modifications.
2. Problems that arise through failure to follow directions in the owner's manual.
3. Exposure of the product to adverse or severe weather conditions, including temperature extremes or water, including rainfall or immersion.
4. Exposure to toxic materials, biohazards, radioactive materials or other contamination.
5. Repairs attempted by parties other than AOR or its authorized personnel.
6. Damage that results from improper installation, including improper voltage and/or reversed polarity, or exposure of a receiver to signal levels exceeding specifications.
7. Damage resulting through the use of accessories from manufacturers other than AOR.
8. Equipment that has had serial numbers removed or altered in any way.
9. Damage that occurred as a result of shipment. Claims must be presented to the carrier.
10. AOR is not responsible for any costs arising from installation or reinstallation of the equipment, nor for any consequential (such as loss of use) damage claims.

### **Obtaining Warranty Service**

1. You are responsible for shipping the product to AOR and any related costs.
2. Warranty claim must be accompanied by a legible copy of the original product purchase receipt.
3. You must include a description of the problem(s) encountered with the product.
4. You must include your name, a valid ground shipping address (including zip code) and telephone contact information.
5. AOR will ship the repaired (or replaced) product by ground transport.

## Limitations

Any and all implied warranties, including those pertaining to merchantability and utility for a specific purpose are limited to the duration of this limited warranty. AOR's limits on warranty pertain only to the repair or, at its option, replacement of defective products. AOR shall not be liable for any other damages, including consequential, incidental or otherwise, arising from any defect.

Some states do not allow limitations on how long an implied warranty lasts and may not allow the exclusion of incidental or consequential damages. As such, the above limitations may not apply in every case. This warranty gives you specific legal rights and you may have other rights that apply in your state.

If you have questions about this limited warranty, or the operation of your AOR product, contact AOR at (310) 787-8615 during normal business hours (9 am ~ 5 pm Pacific Time Zone), or write to AOR, 20655 S. Western Ave., Suite 112, Torrance, CA 90501. You may also send a fax to AOR at (310) 787-8619. Additional information is available at the AOR web site: [www.aorusa.com](http://www.aorusa.com)

We suggest attaching your purchase receipt to this half of the warranty information sheet and that you keep this information in a secure location.

AOR Model Number \_\_\_\_\_

Serial Number \_\_\_\_\_

Dealer Name \_\_\_\_\_

Purchase Date \_\_\_\_\_

AOR, LTD.  
2-6-4, Misuji, Taito-Ku  
Tokyo, 111-0055, Japan  
<http://www.aorja.com>

AOR USA, INC.  
20655 S. Western Ave. Suite 112  
Torrance, CA 90501-1800  
Copyright © 2006  
Phone: 310-787-8615  
Fax: 310-787-8619  
e-mail: [info@aorusa.com](mailto:info@aorusa.com)  
URL: <http://www.aorusa.com>

All rights reserved  
Copyright © 2006