

ART-3000C ROTOR

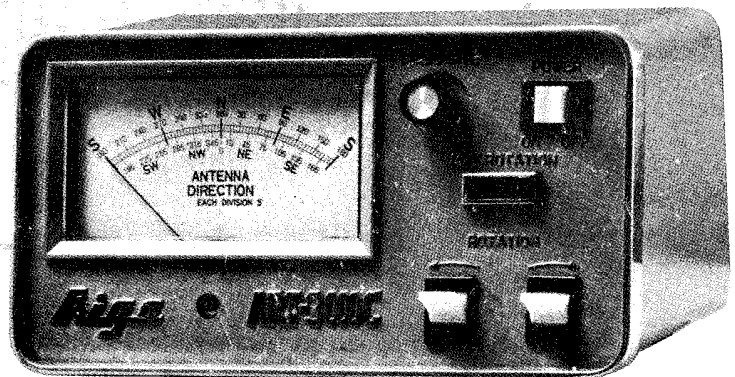
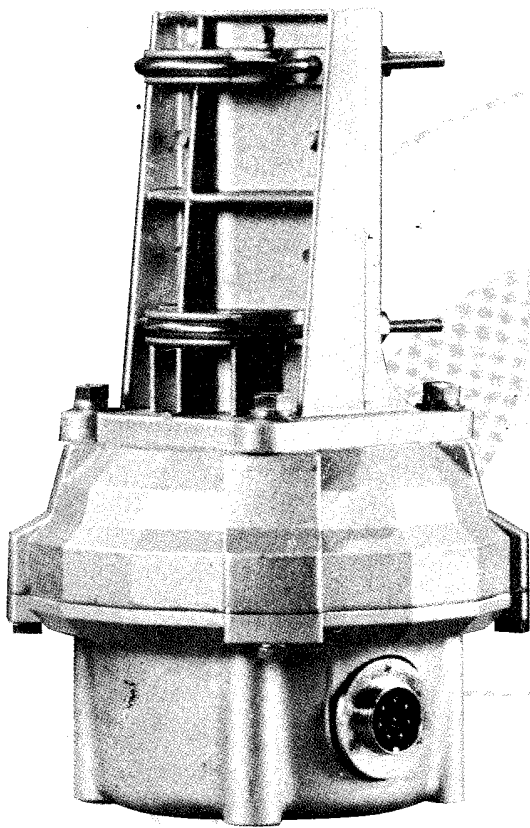

Manufactured by: Aiga Parts Co. Ltd.
Distributed by: Tama Electronics Co. Ltd.

Kimuraya Bldg. 515 Higashi Oizumi Nerima-ku
Tokyo 177. (03) 921-2231. Telex J26155-TAMELEX

ART-3000C SPECIFICATIONS

- Maximum Load:0.54 Square Meters Windload Area
- Housing:Heavy Cast Aluminum
- Motor:High Torque; 800Kg-cm Stall Torque
- Brake Type:Disc
- Brake Torque:1700Kg-cm
- Gears:Stainless Steel Drive
- Bearings:96 Steel Ball Bearings; 350Kg
Balanced Weight Capacity
- Hardware:All Hardware Included, Accepts 35φ to
54φ OD Masts
- Mounting:In-Line or Tower
- Control Cable:8 Conductor; Maximum Resistance 2.5
OHMS
- Input Voltage:100, 220 or 240V AC, 50-60Hz
- Weight:Rotor Only, 5.4Kg
- Control Box Dimensions:17cmW x 8.1cmH x 12.4cmD
- Shipping Weight:8.9Kg
- Rotor Dimensions:18cm Diameter, 43cm Height,
Including Top and Bottom Mounting
Brackets
- Meter Scale:Direct Reading, North Centered,
5° Increments
- Recommended Cable:8 Conductor Weather Proof
- Rotation Time:45-60 Seconds

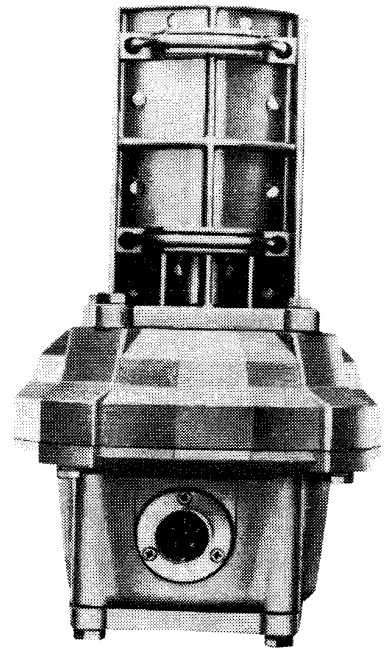

*PINK + BLUE
WIRES TOGETHER*

RED	4	NO. 8
BLK	4	NO. 7
RED	3	NO. 6
BLK	3	NO. 5
RED	2	NO. 4
BLK	2	NO. 3
RED	1	NO. 2
BLK	1	NO. 1

*WIRE
COLOUR CODE*

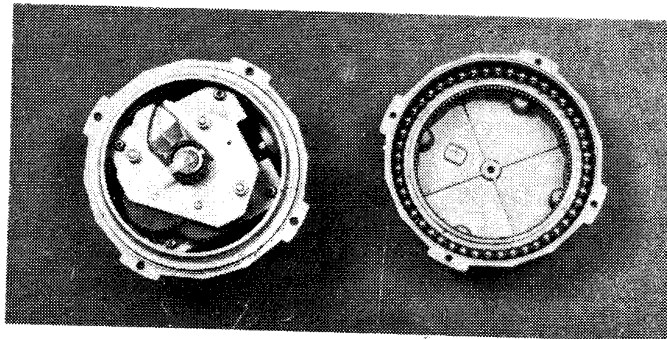

*CALCULATED BEARING
ELEVATION BY MARK NORTH ON OUTSIDE OF CASE*

*TO RESET NORTH
WITHOUT CHECK ANT*

Page Two *POSITION AT MAST* *ROTATE*
ROTATE CAL KNOB FULL ANTIC. TURN TILL M READS 320° NW
RESET CAL NOB TO N°

SECTION I - UNPACKING

1.1 Removing From Carton

Carefully remove rotor from the packing carton and examine it for any signs of shipping damage.

SECTION II - INSTALLATION

2.1 Cable Requirements

Eight wires are required to control the rotor and indicate its position. The cable should be weatherproof and contain eight conductors of #22 copper wire or larger. For cable runs 30 m or longer use a wire size of #20 gauge or larger. For best operation, voltage drop due to line loss should not exceed 2%. However, the rotor will operate with greater voltage drop with only slight degradation of performance. The ART-3000C comes supplied with cable connectors for the control box and the rotor. With the control connector and the rotor connector on the work table, connect the cable between the two connectors. Make sure wires 1, 2, 3, 4, 5, 6, 7, and 8 on the control connector are to 1, 2, 3, 4, 5, 6, 7, and 8 on the rotor connector respectively. Caution: No loose strands of wire should touch adjacent terminals or other metal parts on the connector.

2.2 Pre-Installation Check

It is recommended that a preliminary operational check be made on the rotor system prior to actual installation. With the rotor sitting in the upright position and connected to the control box by the eight wire cable, plug the control box power cord into a convenient AC power socket. Turn the power switch on. The meter should be illuminated. Depress the clockwise rotation switch. The rotor should turn clockwise. This is S-W-N-E-S. Release the rotation switch, rotor will coast down and stop. During rotation, when the end of scale is reached, the maximum rotation light will come on. To turn the rotor counterclockwise, depress the counterclockwise switch. This is S-E-N-W-S. Prior to actual installation, check the calibration and familiarize yourself with this procedure. It is best done while the system is set up for the pre-installation check (see meter calibration).

2.3 Meter Calibration

Rotors are shipped from the factory stopped at the N (North) position. With the power switch on, rotate the rotor clockwise until the end of rotation is reached when the Max. Rotation will light. If the indicator needle does not point S on the right hand side, turn the calibration knob and adjust the indicator to that position. Meter calibration can be performed at any time it is desired to check the accuracy. When power is off, the needle will fall to the left hand south position. When power is on, the needle will indicate the antenna position. It is imperative that the previous calibration instructions are followed and the antenna is mounted in the south position. If an attempt is made to calibrate the antenna in any other position the linearity of the rotor will be degraded and the true indications will be off in varying degrees.

2.4 Rotor Mounting

The ART-3000C rotor system is designed to accommodate light amateur and CB antennas with a maximum of 0.54 sq. meters of wind area. The ART-3000C provides a full 360° range of rotation and a meter scale read-out for accurate position indication. Mast mounting and top plate mounting are the two common ways of mounting the ART-3000C. The ART-3000C rotor is shipped from the factory stopped at the N (North) position. During the preinstallation check, rotate the system (i. e. the rotor properly connected to the control box) clockwise until the end of rotation and by handling the calibration knob adjust the indicator to the right hand S position. Install rotor in this condition and point beam south so that the lead wires will not foul. The rotor mechanism has limit switches in both the clockwise and counterclockwise positions. This prevents the rotor from wrapping up the central cables. Wire up the rotor and control box and apply power, the meter should read south on left side of dial. The center of gravity and center of wind loading force of the antenna should be as close to the top of the rotor casing as possible. 0.3 m to 1 m is practical with most installations. When an antenna with a boom length exceeding 2.4 m is to be mounted more than 2.4 m above the top of the rotor, use of a heavy duty tower with the rotor mounted inside is mandatory. The antenna support then should be a 50ø O. D. steel tube with 6 mm wall rotating in a ball thrust bearing at the top of the tower. The rotor should be mounted inside the tower within 1.2 m of this bearing. All reliable tower manufacturers will be

glad to advise as to the best method for inside mounting with their product. A rugged mount can be made easily with angle iron and U-bolts that will fit any tower. The ART-3000C readily mounts on a pipe or top of tower but certain precautions must be observed to obtain good service. Successful operation of the ART-3000C with moderate size antennas is assured if a proper mechanical installation commensurate with the total size of the entire system is made. Do not attempt to gain another 3 m of height by attempting to mount an antenna of any size on top of a 3.2 cm "TV" mast on top of the rotor. You are just going to pick up pieces after the first wind gust! If there is any doubt about a top mount, then we recommend investing in a good inside tower installation. It's an excellent investment. Caution: The rotor is designed for vertical operation with the bell shaped housing in the up position. Water and other contamination will get into the motor unit if mounted horizontal or upside down.

SECTION III - OPERATION

3.1 Mechanical Operation

To prevent binding under adverse operating conditions, a small amount of play is designed into the rotor. Even a degree or so of rotor play will permit about 10 cm of movement at the end of a long antenna boom, or at the tips of the elements. Frequently, the slight motion of the antenna array in gusts of winds is due more to the natural flexing of the elements and mast than it is due to actual play in the rotor mechanism. Occasionally in very high winds the disc brake on the ART-3000C may slip; it takes approximately 1500 kg cm of force to overcome the disc brake. This generally will not occur unless the antenna is very large. Another problem regarding antenna slippage is a matter of the antenna slipping in the mast support. A false indication of suspected slipping may be indicated on the meter. Compare meter readings at different times when the rotor has not been activated. Check the nuts on the U-bolts so that they are tight.

3.2 Electrical Operation

Field experience has shown that most operational difficulties with the rotor are traceable to broken, shorted, or grounded wires, usually at the connectors. Time spent in cutting the leads to exact length, tinning, forming, cutting insulation to

exact lengths and clamping to prevent strain on any single wire on the connector will pay big dividends later in long and trouble free performance. Put it up right and leave it up!

CAUTION:

3.3 Shock Hazard

BEFORE CLIMBING TOWER AND/OR PERFORMING ANY MAINTENANCE ON THE ATR-3000C TOWER SYSTEM OR YOUR ANTENNA SYSTEM, MAKE CERTAIN ALL A.C. POWER IS DISCONNECTED FROM YOUR INDICATOR UNIT.

Pin 1 = BROWN - WHITE - PURPLE

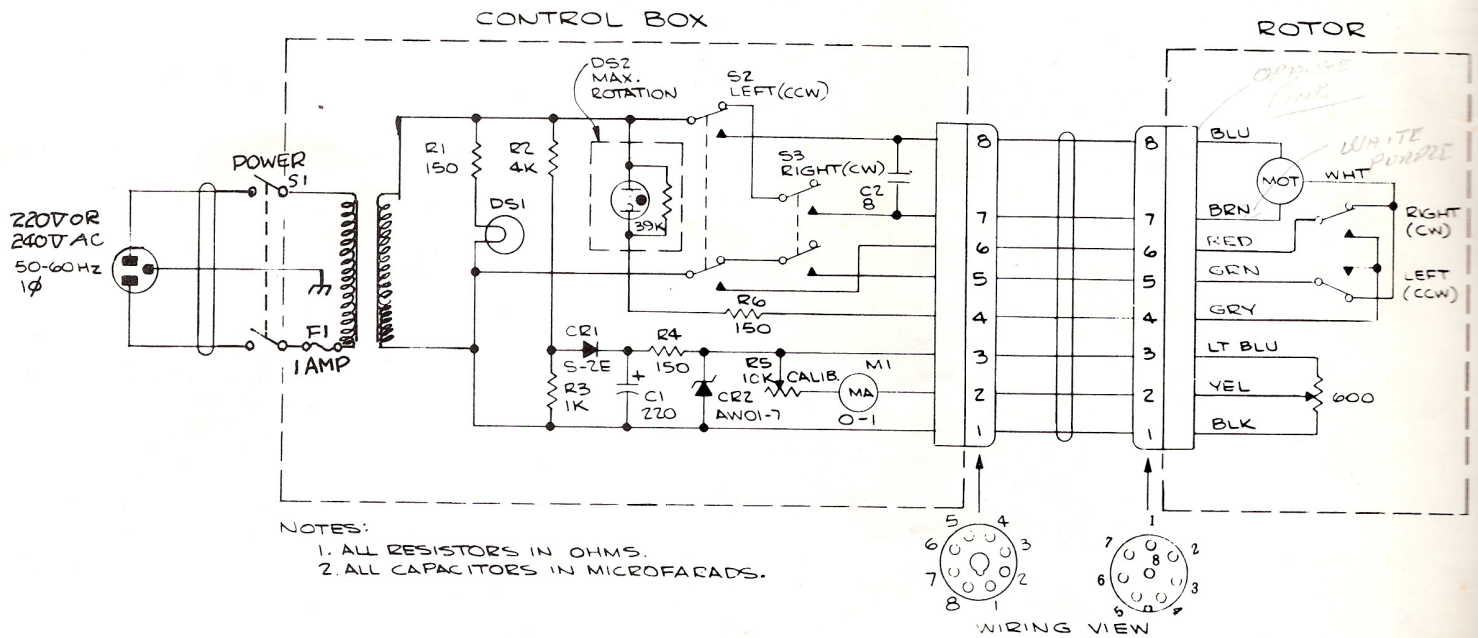

ROTOR SCHEMATIC

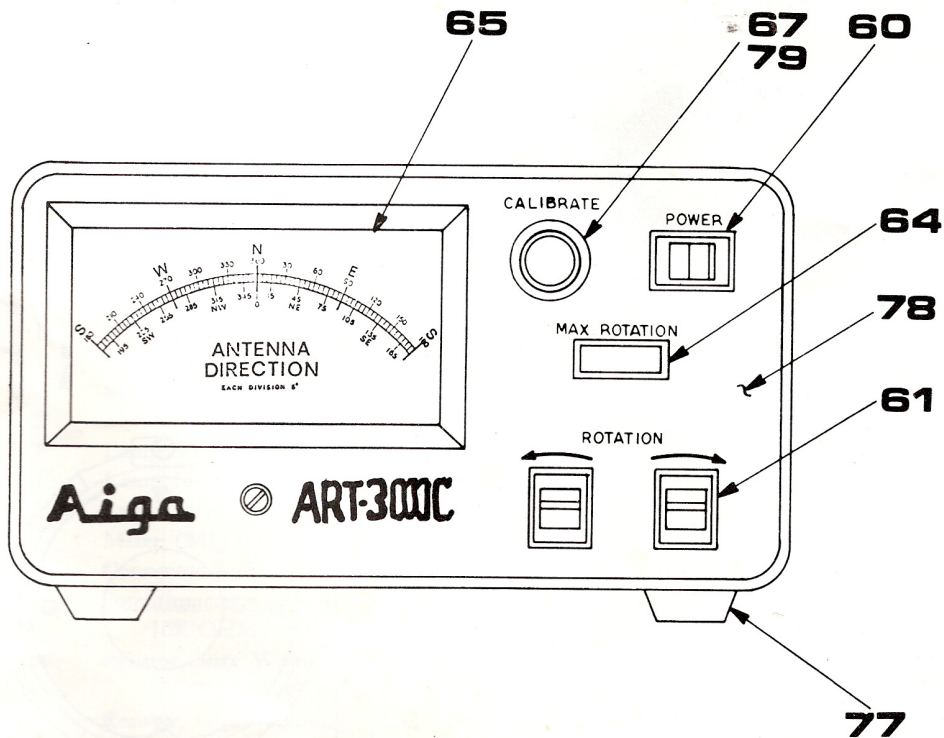

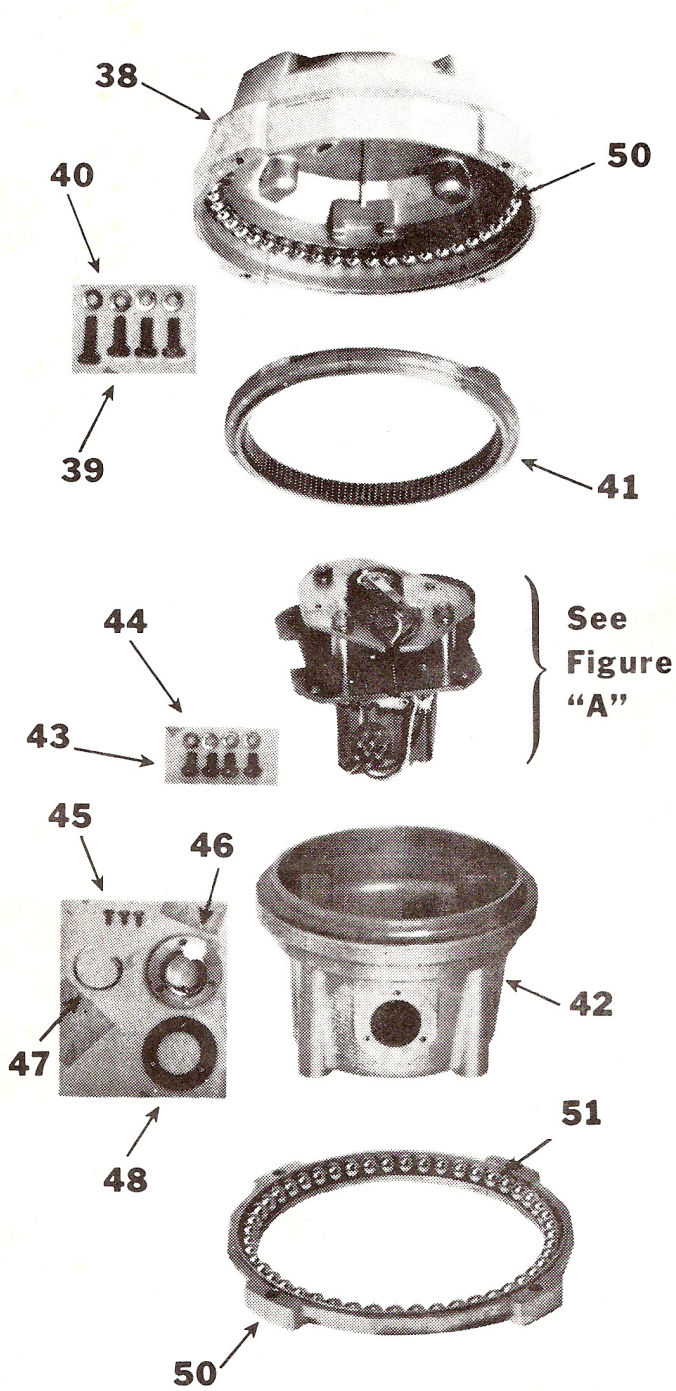

See Figure "A"

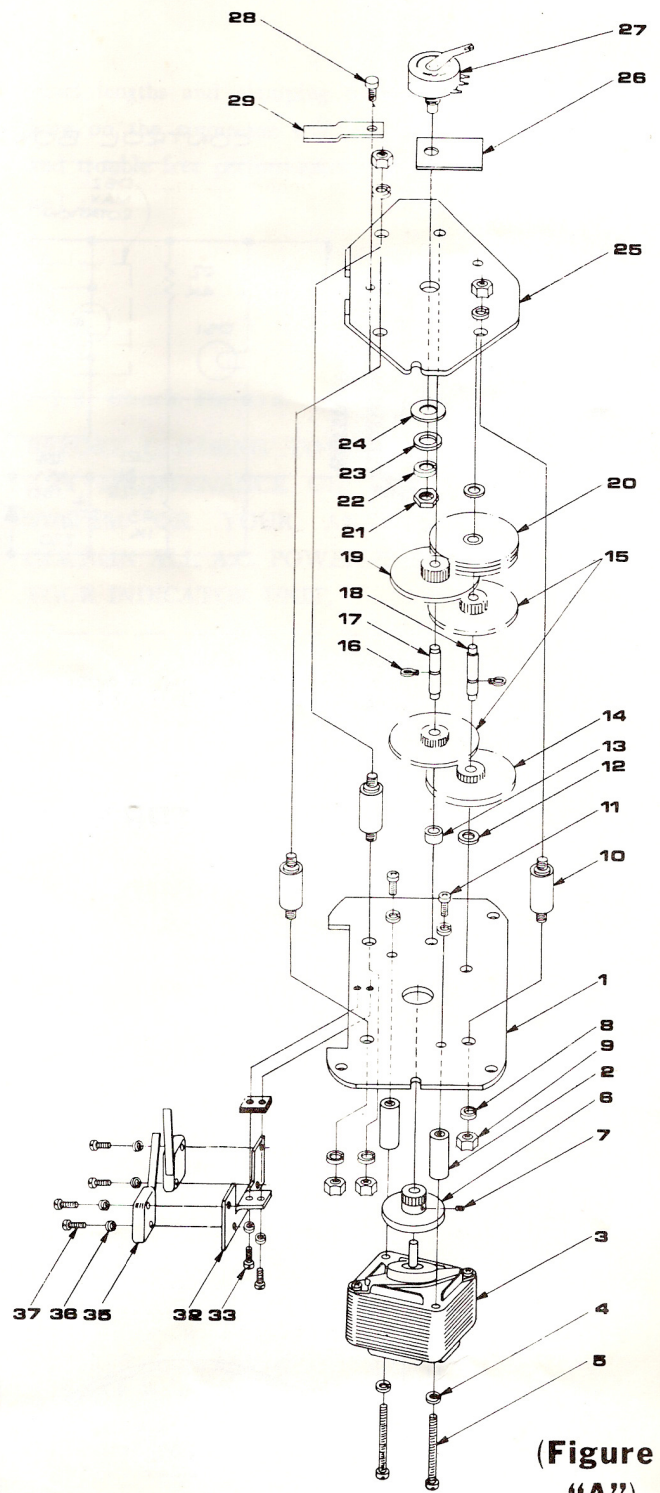

(Figure "A")

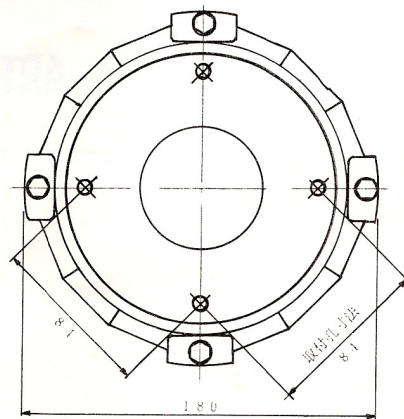
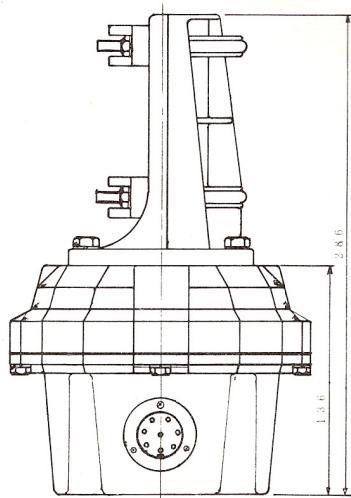

ROTOR PARTS LIST

ITEM NO.	PART NO.	QTY.	DESCRIPTION	ITEM NO.	PART NO.	QTY.	DESCRIPTION
1	5001	1	Motor Mount Plate	27	5027	1	Pot
2	5002	2	Motor Support Sleeve	28	5028	1	Stopper Bar Screw (5φ)
3	5003	1	Motor	29	5029	1	Rotation Stopper Bar
4	5004	2	Lock Washer (4φ)	32	5032	1	Switch Plate Insulator
5	5005	2	Motor Mount Screw (4φ)	33	5033	2	Switch Plate Screw (3φ)
6	5006	1	Brake/Pinion	35	5035	2	Switch
7	5007	1	Set Screw (3φ)	36	5036	4	Lock Washer (3φ)
8	5008	6	Lock Washer (6φ)	37	5037	4	Switch Mount Screw (3φ)
9	5009	6	Nut (6φ)	38	5038	1	Upper Housing
10	5010	3	Motor Mount Support	39	5039	4	Housing Screw (6φ)
11	5011	2	Motor Support Sleeve Screw(4φ)	40	5040	4	Lock Washer (6φ)
12	5012	2	Shim Washer	41	5041	1	Ring Gear
13	5013	1	Shim Sleeve	42	5042	1	Lower Housing
14	5014	1	Plastic Gear	43	5043	4	Housing Screw (5φ)
15	5015	2	Pinion Gear	44	5044	4	Lock Washer (5φ)
16	5016	2	C-Ring	45	5045	1	Connector
17	5017	1	Shaft	46	5046	1	Connector Shell
18	5018	1	Shaft	47	5047	1	Shell Retaining Ring
19	5019	1	Pinion Gear	48	5048	1	Connector Gasket
20	5020	1	Drive Gear	49	5049	3	Connector Shell Screw
21	5021	1	Nut (9φ)	50	5050	96	Bearing
22	5022	1	Lock Washer (9φ)	51	5051	1	Bearing Race
23	5023	1	Washer (9φ)	52	5052	1	Mast Holder
24	5024	1	Shim Washer (9φ)	53	5053	2	Mast Clamp
25	5025	1	Gear Plate	54	5054	2	U-Bolt
26	5026	1	Pot Insulator				

Note : φ = Millimeters

80	5080	1	Connector, 8 Pin Female, Weather Proof
81	5081	1	Connector, 8 Pin Male, Octal

Note : Parts 80 & 81 above furnished with Rotor-Packed in Hardware Package

CONTROL BOX PARTS LIST

ITEM NO.	PART NO.	QTY.	DESCRIPTION	ITEM NO.	PART NO.	QTY.	DESCRIPTION
57	5057	1	Line Cord/Plug	70	5070	1	Resistor, Wire Wound, 4K OHMS, 5W (R3)
58	5058	1	Fuse Holder	71	5071	1	Diode, 100V P.I.V. #S-2E (CR1)
59	5059	1	Fuse, 1 Amp (F1)	72	5072	1	Diode, Zener #AWO 1-7(CR2)
60	5060	1	Switch, Rocker, SPST (S1)	73	5073	1	Capacitor, Electrolytic, 220 UF, 25V (C1)
61	5061	2	Switch, Rocker, DPDT(S2, S3)	74	5074	1	Capacitor, Non-Polarized, 8 UF, 250V (C2)
62	5062	1	Lamp Socket	75	5075	1	Terminal Strip, 14 Terminals
63	5063	1	Lamp, Incandescent, 110V(DS1)	76	5076	1	Chassis, 2 Parts, Includes Mounting Hardware
64	5064	1	Lamp Cartridge, Red Neon(DS2)	77	5077	4	Rubber Feet
65	5065	1	Meter (M1)	78	5078	1	Front Panel, Includes Mounting Hardware
66	5066	1	Connector Socket, 8 Pin Female	79	5079	1	Knob-With Set Screw
67	5067	1	Potentiometer, 10K OHMS, B Taper (R5)				
68	5068	3	Resistor, wire Wound, 150 OHMS, 1W (R1.R4.R6)				
69	5069	1	Resistor, wire Wound, 2K OHMS, 5W (R2)				