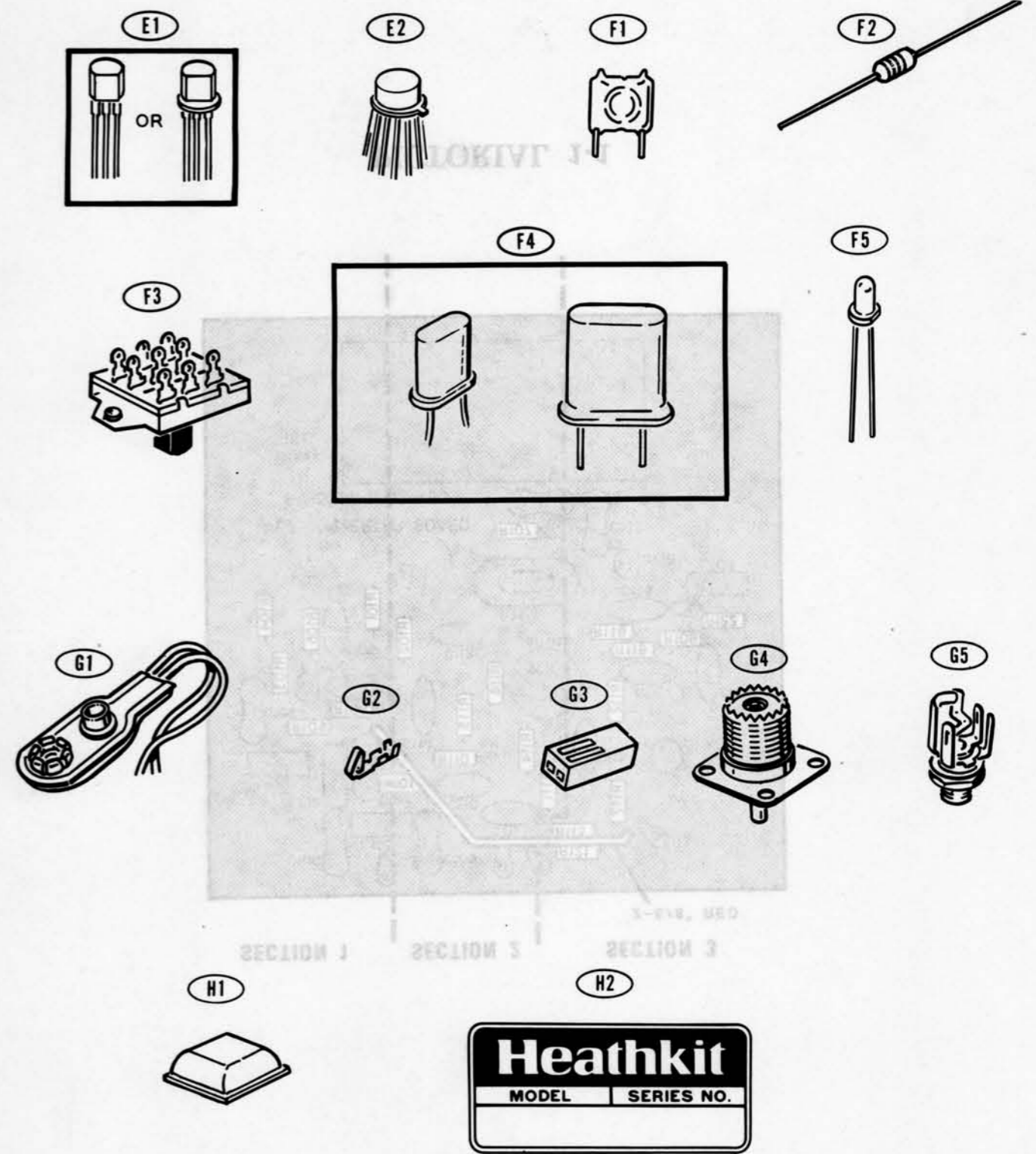
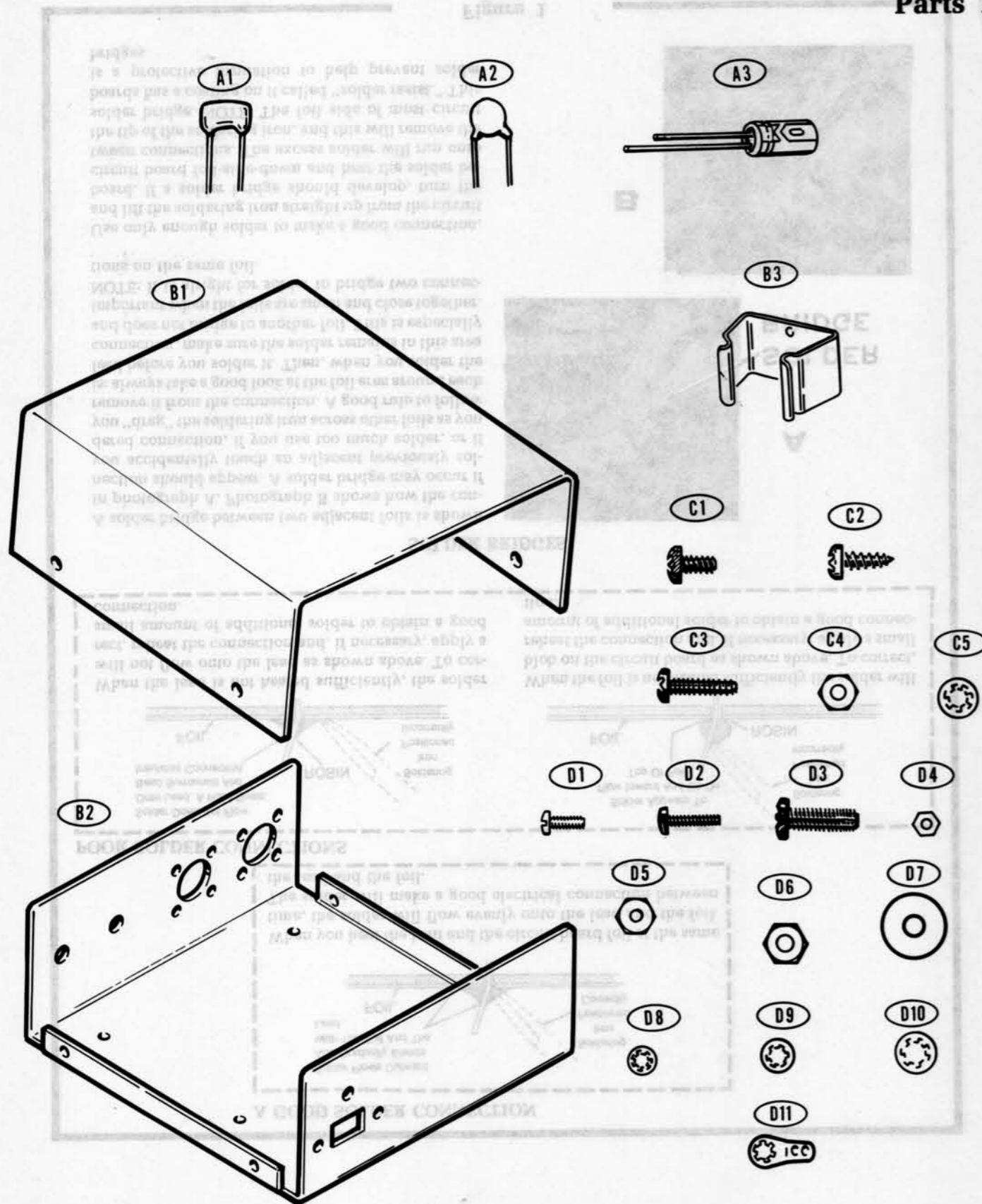


ILLUSTRATION BOOKLET

Part of 595-3468-01

Parts Pictorial

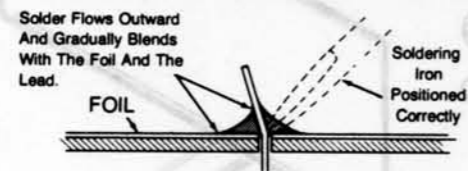


Heathkit
MODEL SERIES NO.

Model HD-1420

Copyright ©1985
Heath Company
All Rights Reserved
Printed in the United States of America

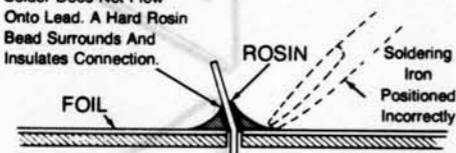
A GOOD SOLDER CONNECTION



When you heat the lead and the circuit board foil at the same time, the solder will flow evenly onto the lead and the foil. The solder will make a good electrical connection between the lead and the foil.

POOR SOLDER CONNECTIONS

Solder Does Not Flow Onto Lead. A Hard Rosin Bead Surrounds And Insulates Connection.



When the lead is not heated sufficiently, the solder will not flow onto the lead as shown above. To correct, reheat the connection and, if necessary, apply a small amount of additional solder to obtain a good connection.

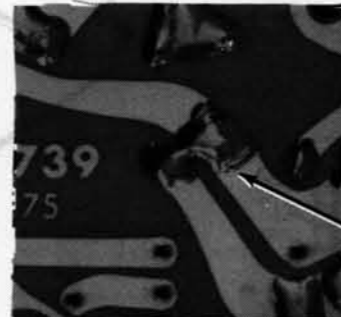
Solder Appears To Flow Inward And Sit On Top Of Foil.



When the foil is not heated sufficiently the solder will blob on the circuit board as shown above. To correct, reheat the connection and, if necessary, apply a small amount of additional solder to obtain a good connection.

SOLDER BRIDGES

A solder bridge between two adjacent foils is shown in photograph A. Photograph B shows how the connection should appear. A solder bridge may occur if you accidentally touch an adjacent previously soldered connection, if you use too much solder, or if you "drag" the soldering iron across other foils as you remove it from the connection. A good rule to follow is: always take a good look at the foil area around each lead before you solder it. Then, when you solder the connection, make sure the solder remains in this area and does not bridge to another foil. This is especially important when the foils are small and close together. NOTE: It is alright for solder to bridge two connections on the same foil.



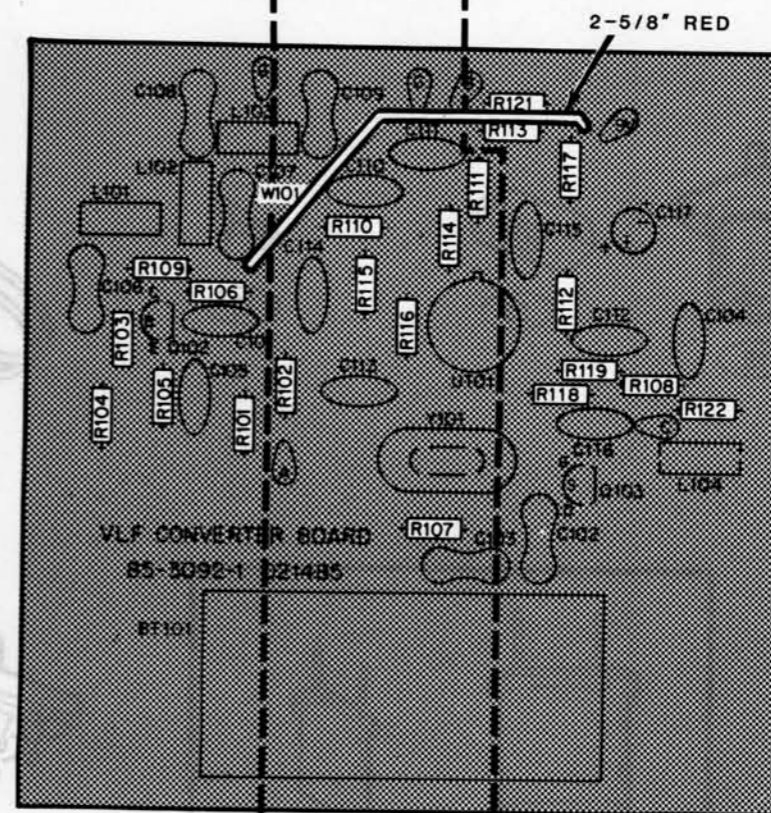
SOLDER BRIDGE

Use only enough solder to make a good connection, and lift the soldering iron straight up from the circuit board. If a solder bridge should develop, turn the circuit board foil-side-down and heat the solder between connections. The excess solder will run onto the tip of the soldering iron, and this will remove the solder bridge. NOTE: The foil side of most circuit boards has a coating on it called "solder resist." This is a protective insulation to help prevent solder bridges.

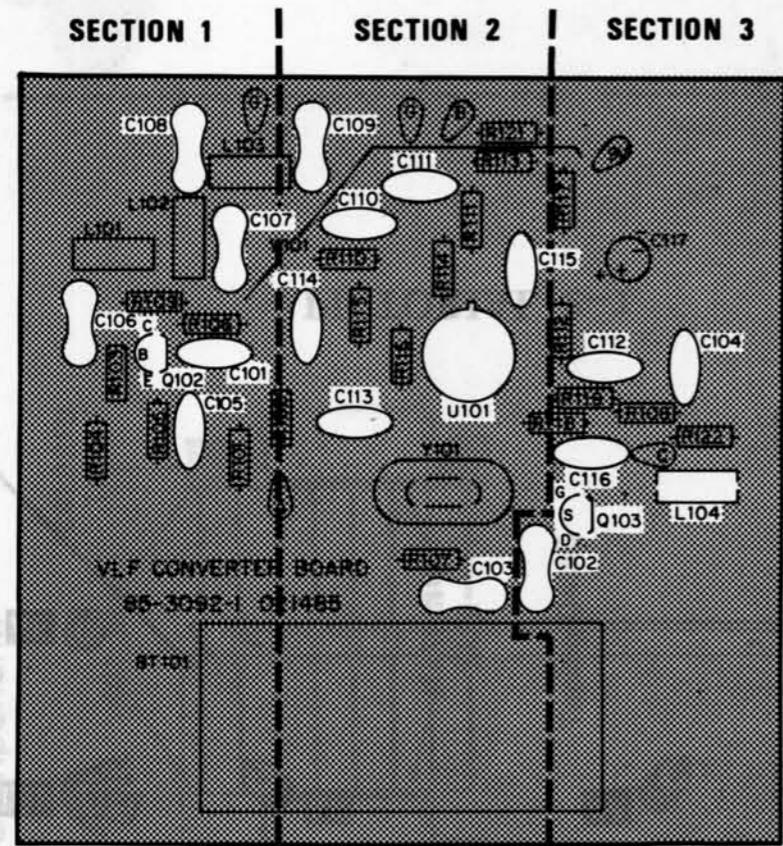


Figure 1

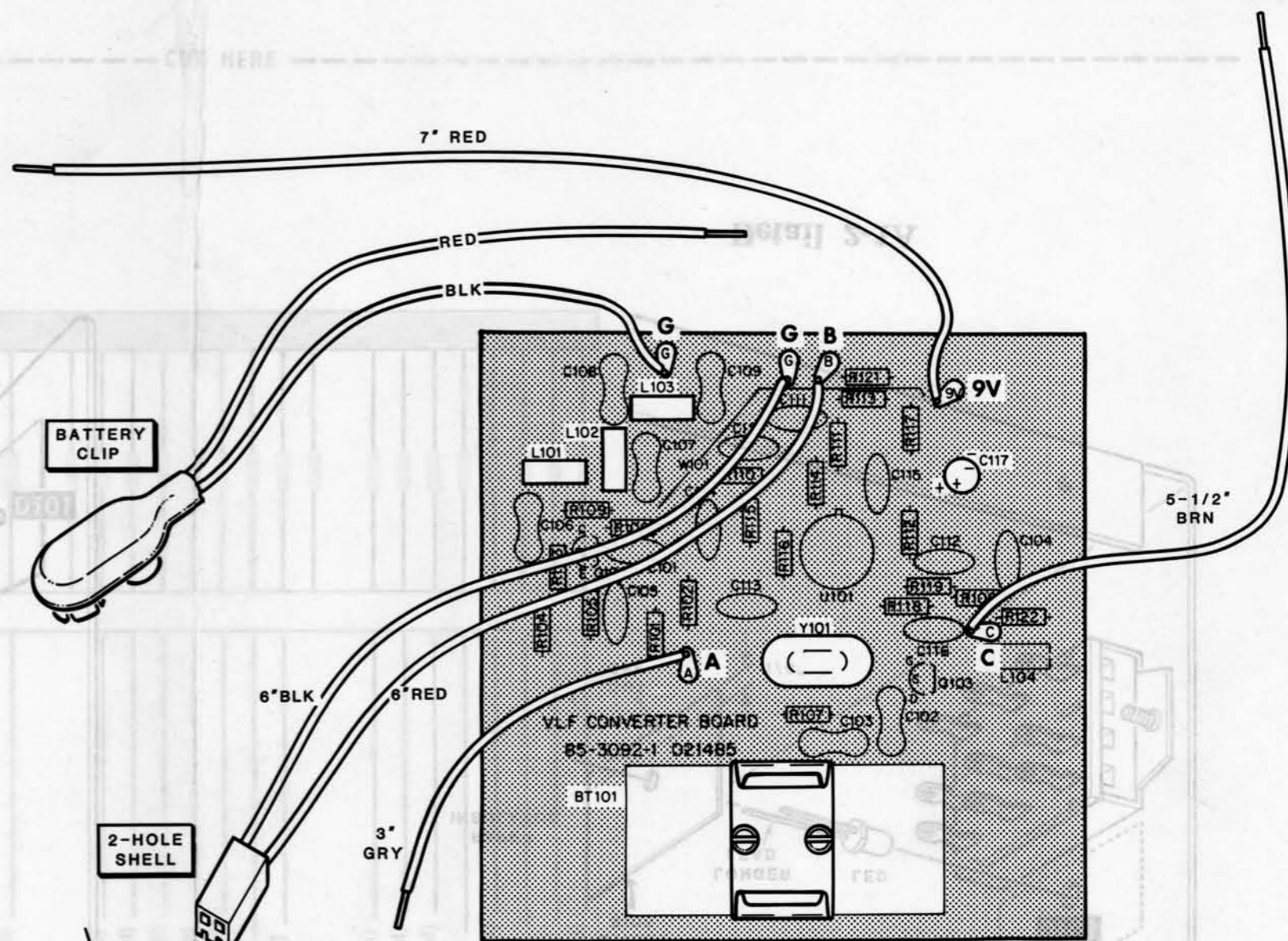
SECTION 1 SECTION 2 SECTION 3



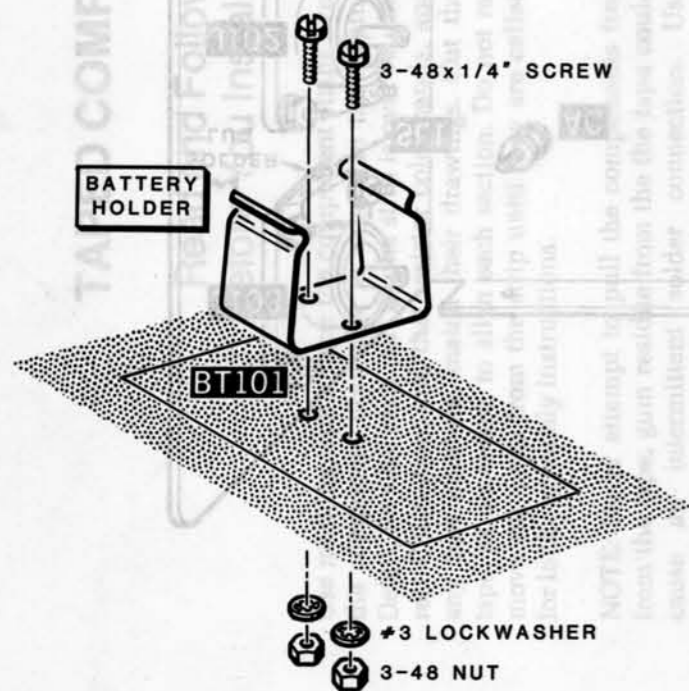
PICTORIAL 1-1



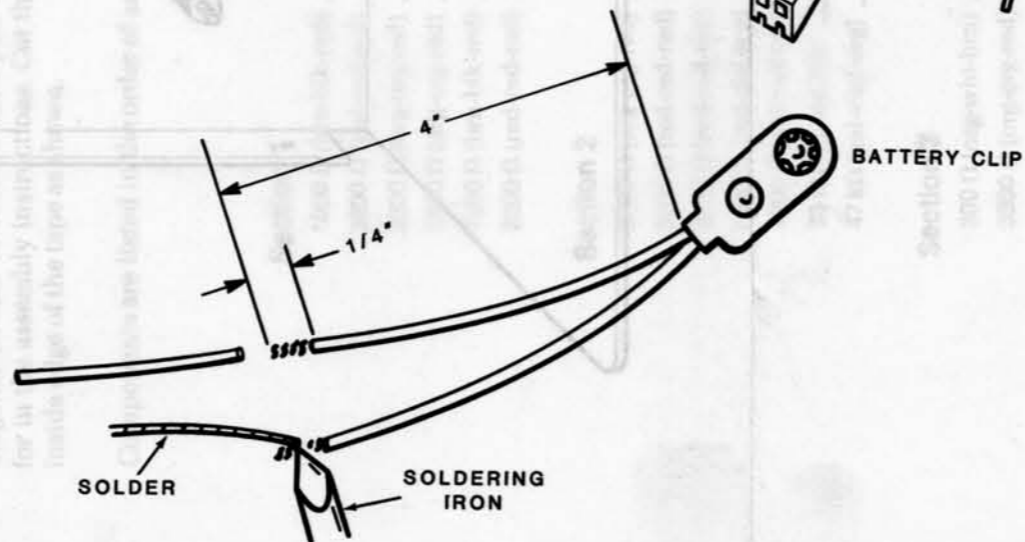
PICTORIAL 1-2



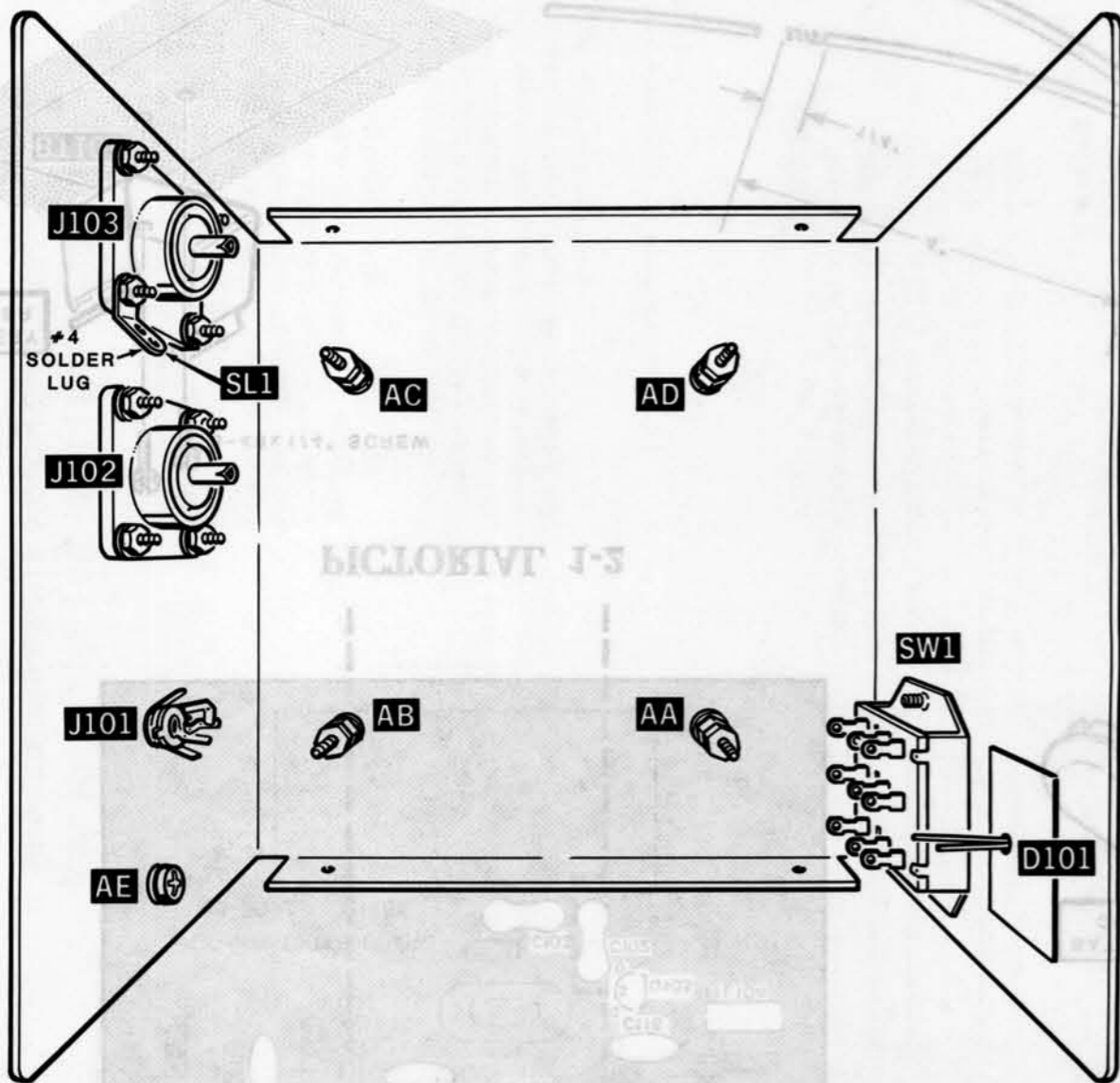
PICTORIAL 1-3



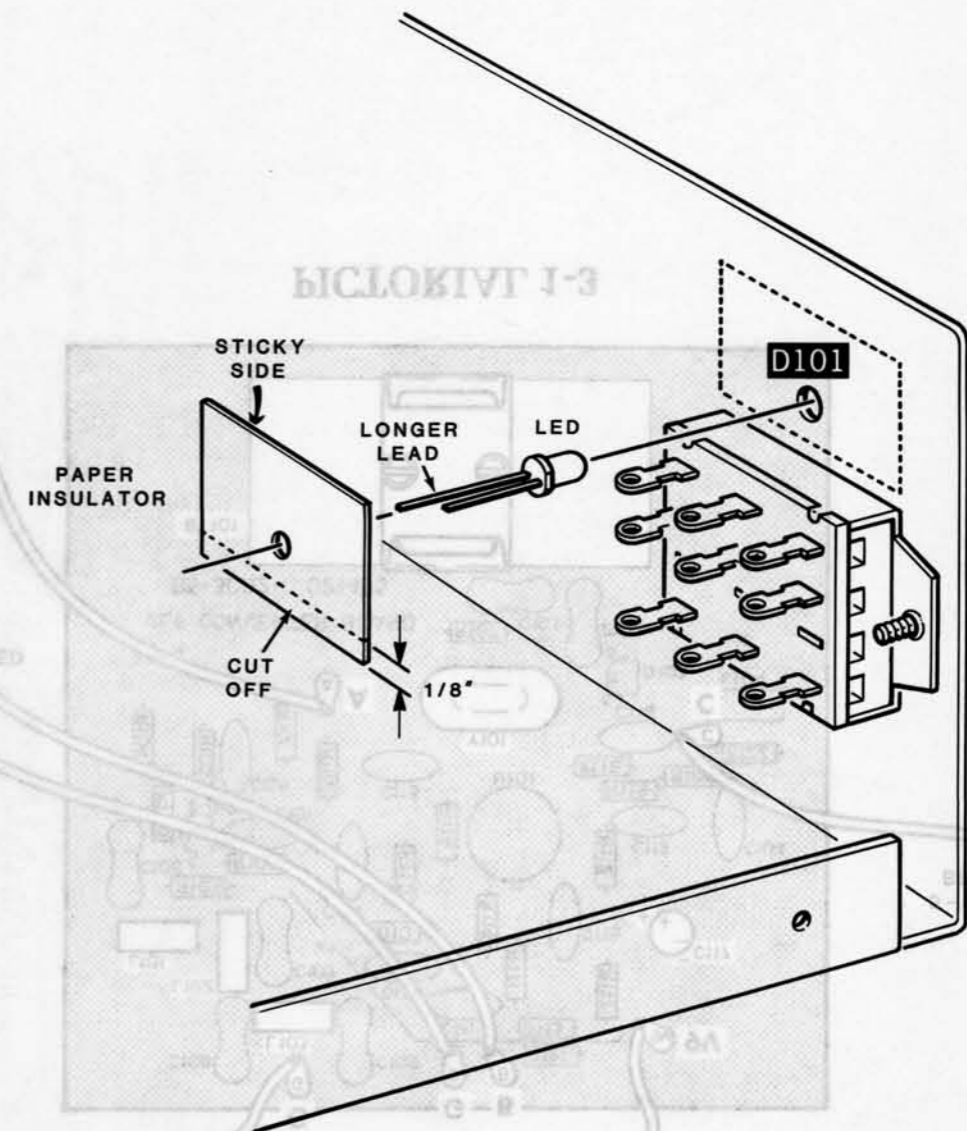
Detail 1-3A



Detail 1-3B

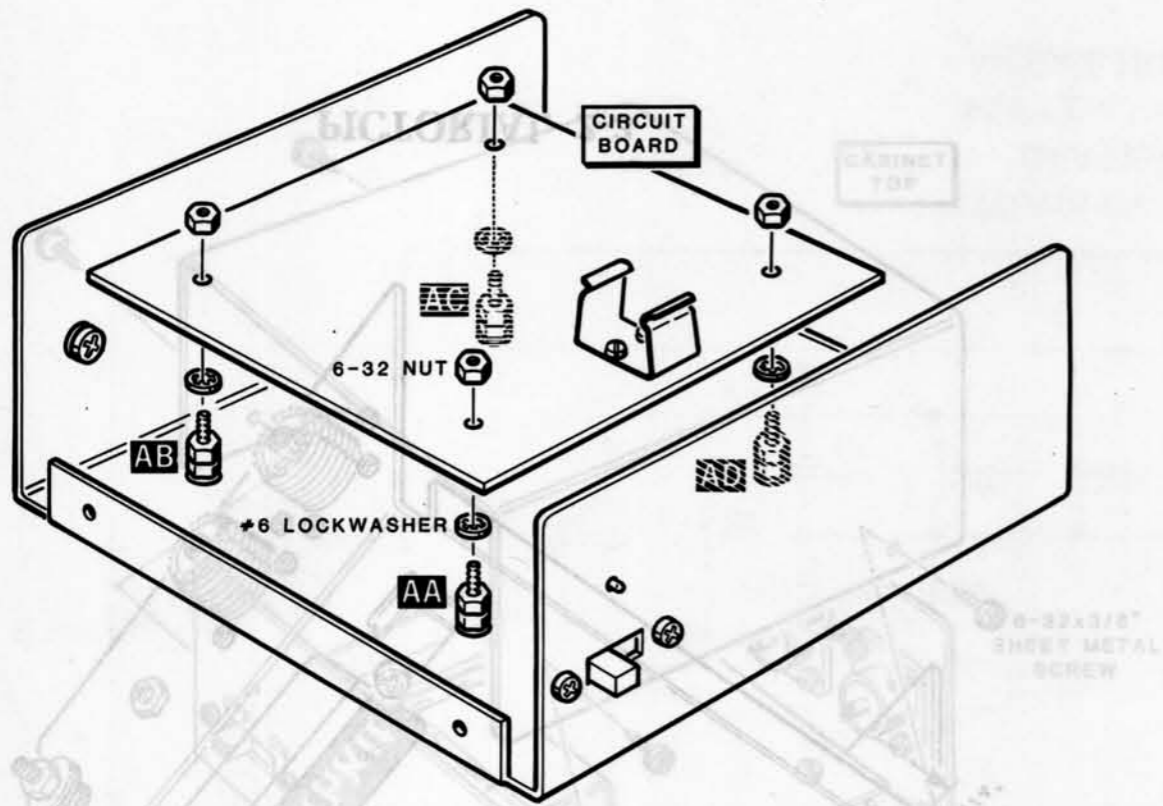


PICTORIAL 2-1

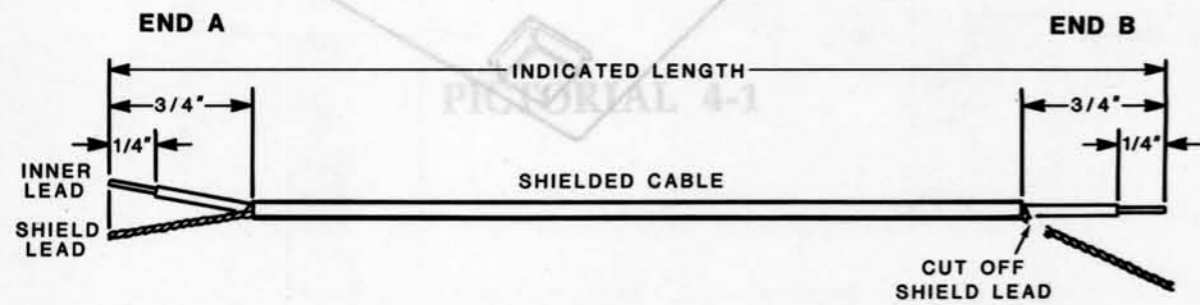


Detail 2-1A

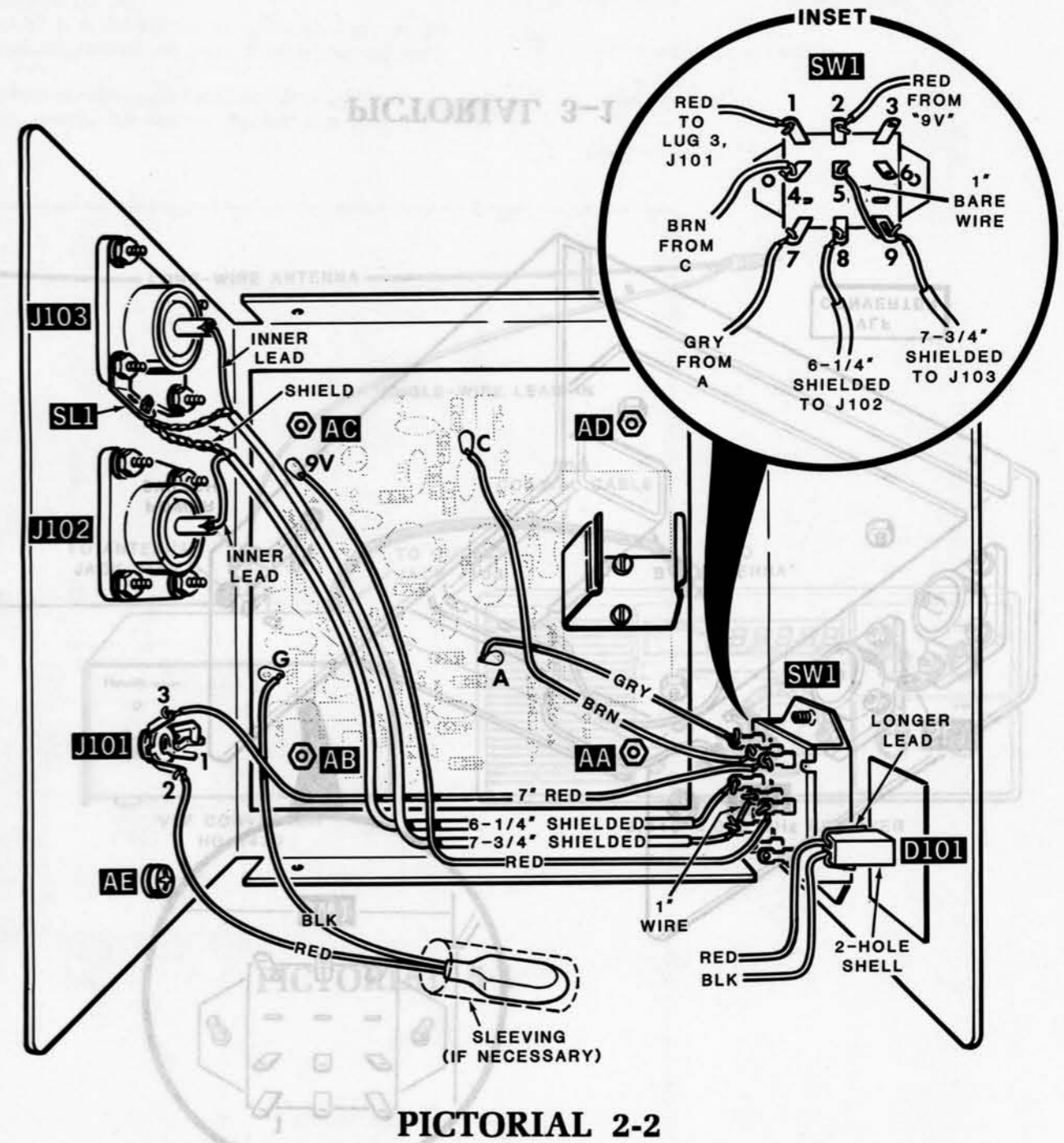
SECTION 1 SECTION 5 SECTION 3



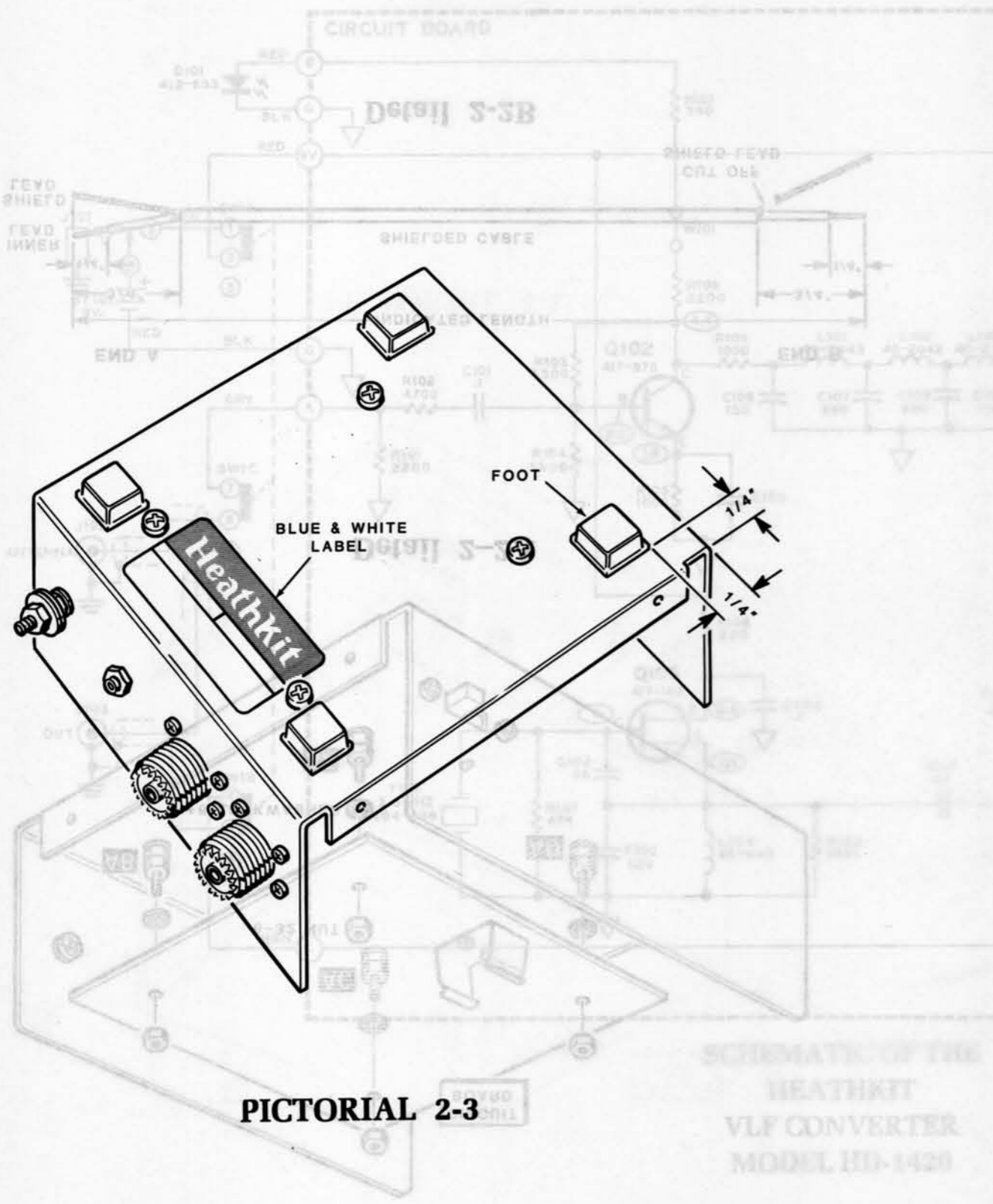
Detail 2-2A



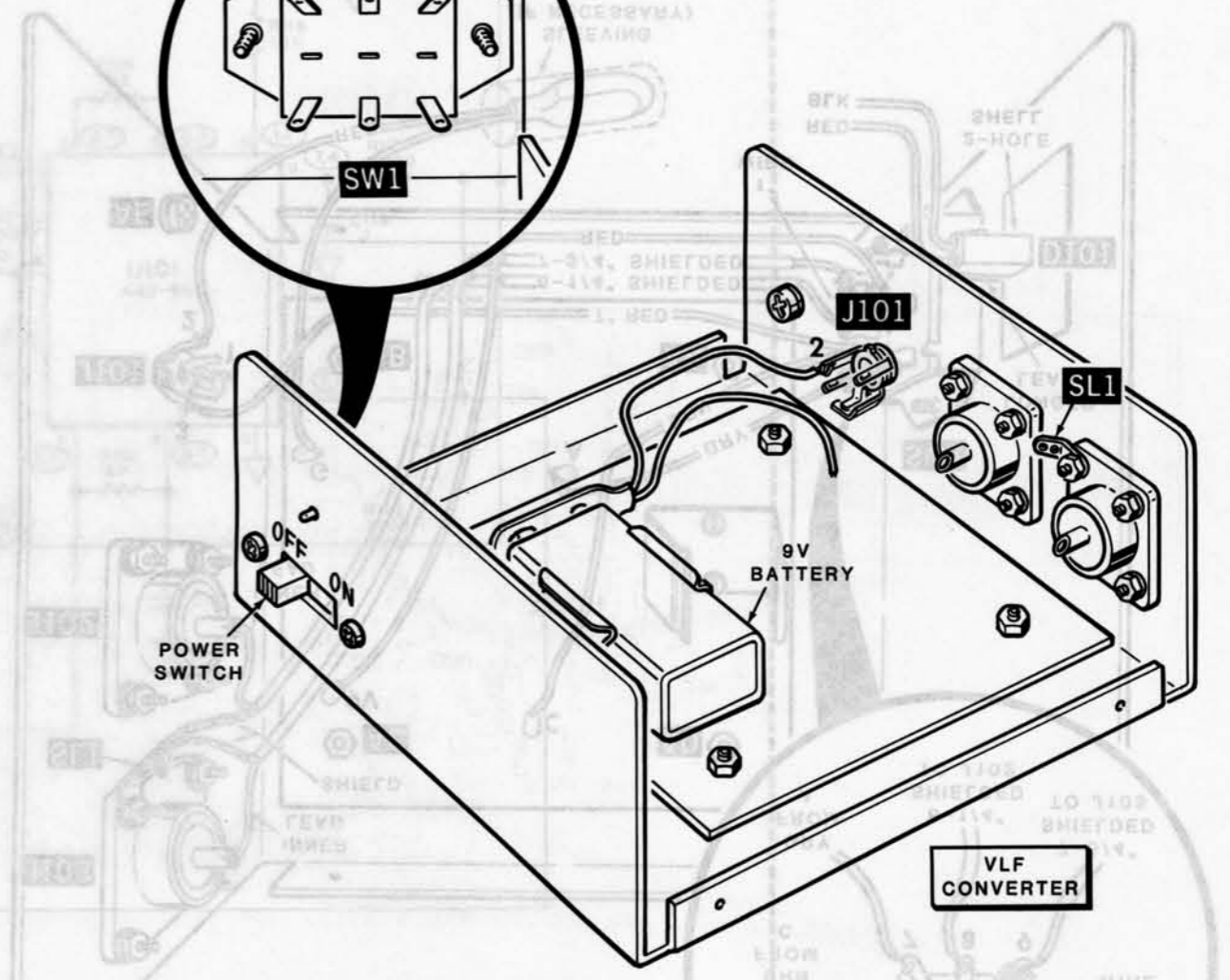
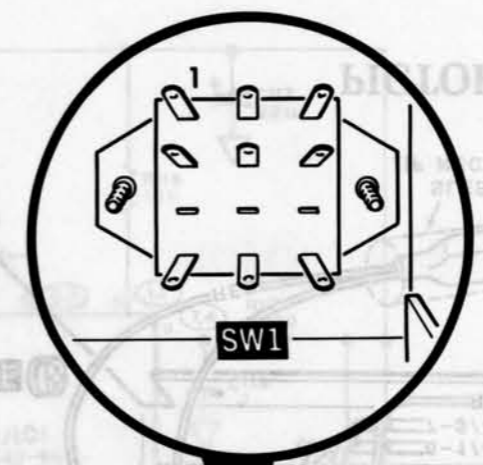
Detail 2-2B



PICTORIAL 2-2

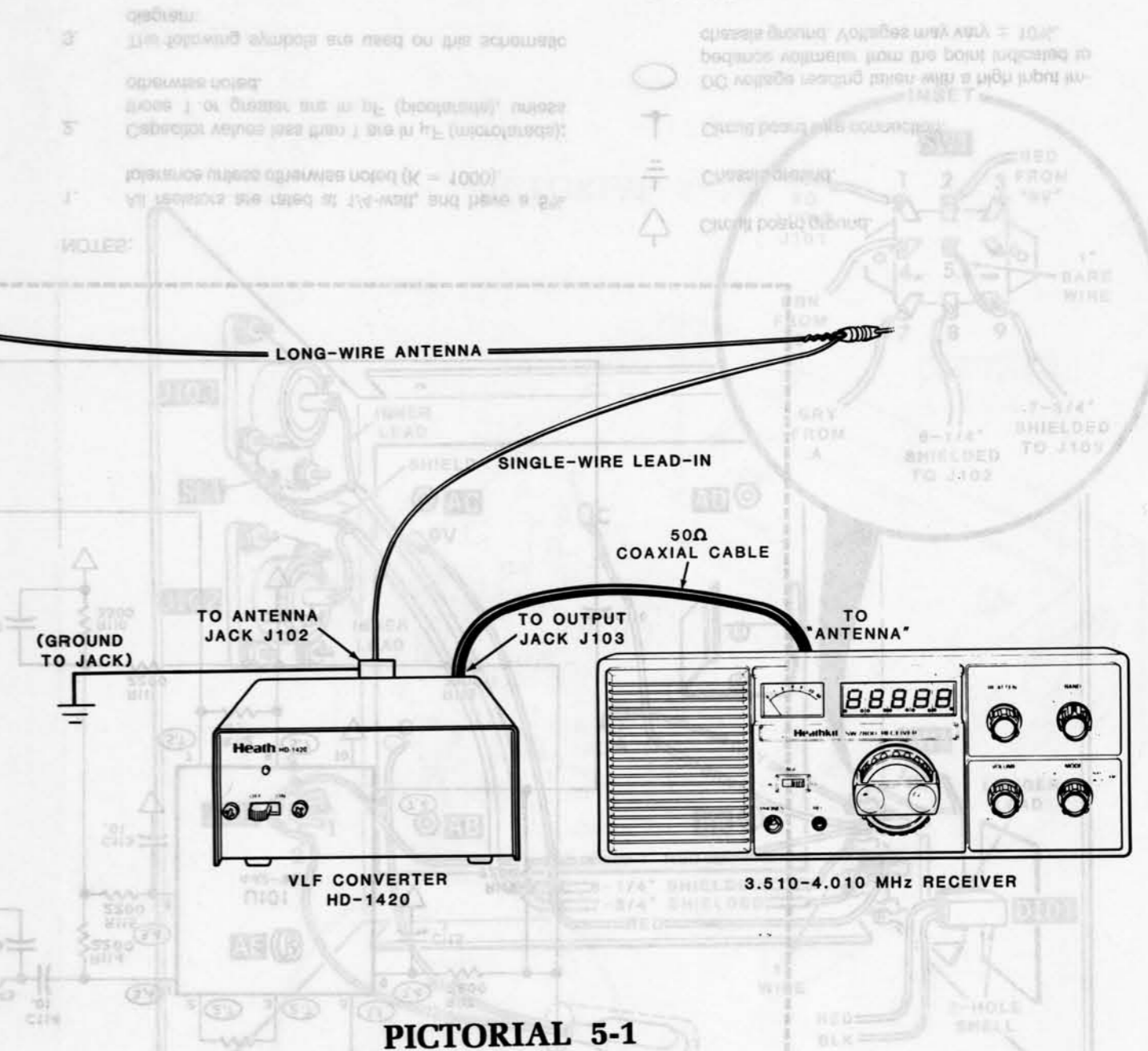
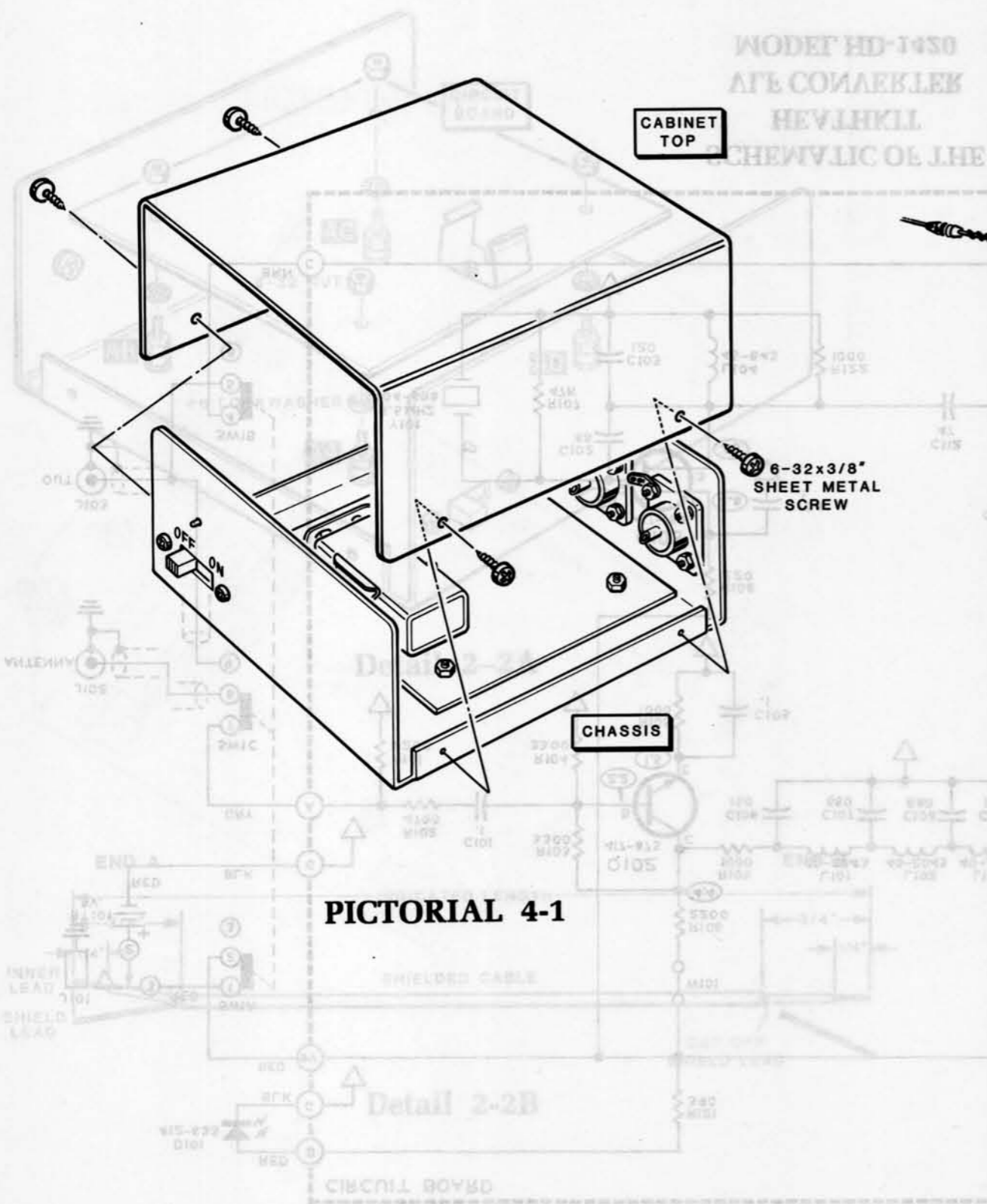


PICTORIAL 2-3



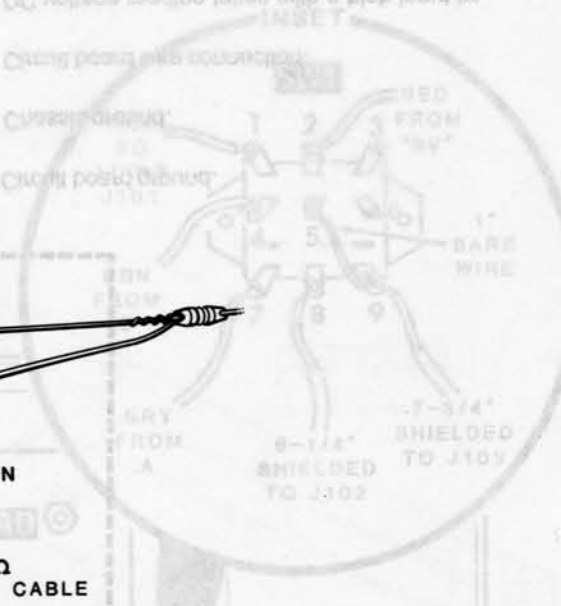
PICTORIAL 3-1

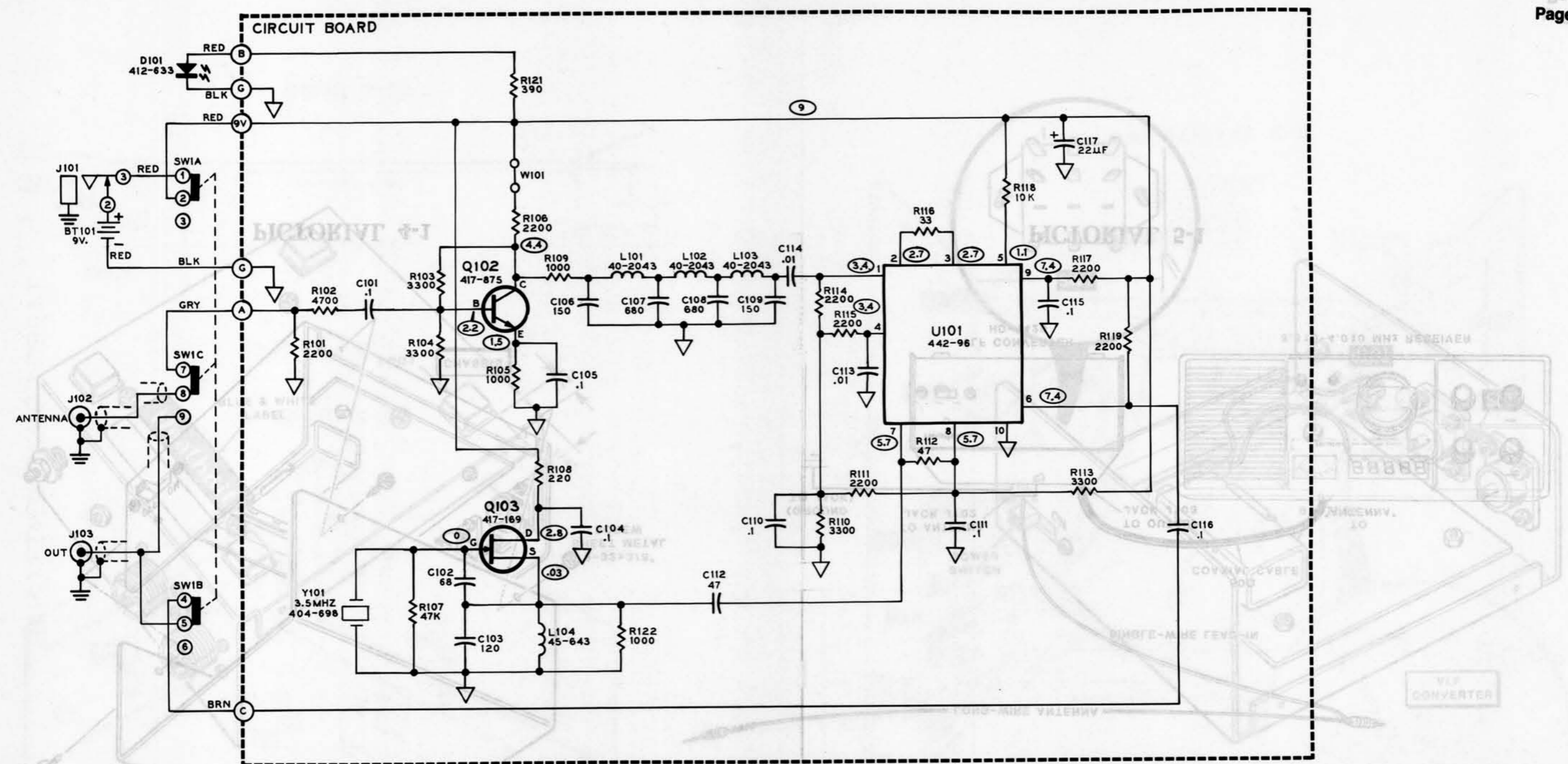
- NOTES:
1. All voltages are rated at 114-volt, and tolerance unless otherwise noted.
 2. Capacitor values less than 1 are in pF (picofarads); those 1 or greater are in μF (microfarads), unless otherwise noted.
 3. The following symbols are used on this schematic diagram:
 - DC voltage reading taken with a high input impedance voltmeter from the point indicated to chassis ground. Voltages may vary ± 10%.
 - ⊕ Switch SW1 is shown in the "on" position.
 - ⊙ Refer to the "Circuit Board & Resistor Values" on Page 20 for component values.



Learned to wait for X-ray tubes and other
 parts to arrive in the mail, on hand
 nothing, the wire in the "on" position





- 1. Check the "on" position
- 2. Check the "off" position
- 3. Check the "on" position
- 4. Check the "off" position





**SCHEMATIC OF THE
HEATHKIT
VLF CONVERTER
MODEL HD-1420**

- NOTES:**
- All resistors are rated at 1/4-watt, and have a 5% tolerance unless otherwise noted (K = 1000).
 - Capacitor values less than 1 are in μF (microfarads); those 1 or greater are in pF (picofarads), unless otherwise noted.
 - The following symbols are used on this schematic diagram:

-  Circuit board ground.
-  Chassis ground.
-  Circuit board wire connection.
-  DC voltage reading taken with a high input impedance voltmeter from the point indicated to chassis ground. Voltages may vary $\pm 10\%$.

- Switch SW1 is shown in the "on" position.
- Refer to the "Circuit Board X-Ray View" on Manual Page 23 for the physical locations of parts.

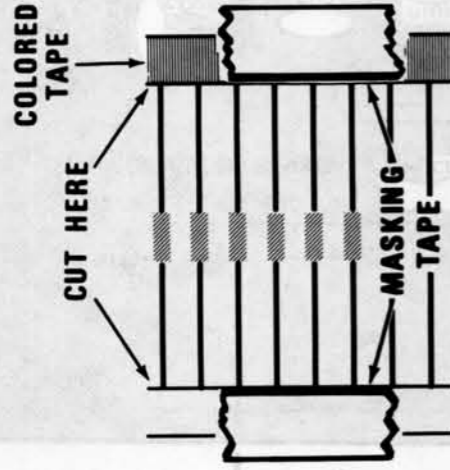
TAPED COMPONENTS CHART

Read and Follow These Instructions Before You Install the First Component.

Use masking tape to tape the component strips over the component drawings, as shown in the Taping Detail. Be sure each part on the strip is over its correct illustration; and that resistor color bands, and any part numbers, match their drawings. Cut the tape, as necessary, to align each section. Do not remove any parts from the strip until they are called for in the assembly instructions.

NOTE: Never attempt to pull the components free from the tape; gum residue from the tape could cause an intermittent solder connection. Use diagonal cutters to remove each part as it is called for in the assembly instructions. Cut the leads at the inside edge of the tape as shown.

Components are listed in the order of assembly.



Taping Detail

Section 1

- 1000 Ω (brn-blk-red)
- 2200 Ω (red-red-red)
- 3300 Ω (org-org-red)
- 3300 Ω (org-org-red)
- 1000 Ω (brn-blk-red)
- 2200 Ω (red-red-red)

Section 2

- 3300 Ω (org-org-red)
- 2200 Ω (red-red-red)
- 2200 Ω (red-red-red)
- 2200 Ω (red-red-red)
- 4700 Ω (yel-viol-red)
- 33 Ω (org-org-blk)
- 47 k Ω (yel-viol-org)

Section 3

- 390 Ω (org-wht-brn)
- 3300 Ω (org-org-red)
- 2200 Ω (red-red-red)
- 47 Ω (yel-viol-blk)
- 2200 Ω (red-red-red)
- 10 k Ω (brn-blk-org)
- 220 Ω (red-red-brn)
- 1000 Ω (brn-blk-red)

CUT HERE

Detail 1-3A

Detail 1-3B

PICTORIAL 1-3