

The Restoration of a ‘Parts Set’ Eddystone S.940: Part 1 - Cleanup, Mechanical /Electronic Repairs and ‘Jump Starting’ – by Gerry O’Hara, G8GUH

The Eddystone ‘Stop Gap’ That More Than Made The Grade

The story goes that the S.940 was conceived, designed and entered production within a few months in 1962 when the sales director of Eddystone noted that there was a gap in the market between the expensive high-end ‘professional’ sets of the time and those for the ‘civilian’ market, eg. S.840C. A mid-priced general coverage set of good quality and reasonable feature set was therefore needed. Bill Cooke was tasked with designing such a set and to use as many ‘stock parts’ as possible, targeting a street-price of around 100 pounds. And so the S.940 was born - nothing really fancy, just a solid, not-too-many frills, well-made single-conversion communications receiver for the more discerning short wave enthusiast (or the ‘well-heeled’ radio amateur as some have put it), all in the new-style case. Although not quite in the same league in terms of mechanical construction as its contemporary ‘professional’ sets, eg. 830 series and 770 series, it did its job pretty well and has proved to be a reliable and popular stalwart of the Eddystone marque. Its position in the marketplace meant that the vast majority of these receivers went into private hands – usually meaning that they were not worked as hard as those in professional use and were likely to have been looked after as a personal ‘pride and joy’ for many years following the high price paid (even if you were ‘well-heeled’) - rather than it being merely a tool in someone else’s toolkit - the ‘nobody ever washed a rental car’ syndrome.

Both the S.940 circuit and mechanical construction are interesting and although many features and circuit elements are derived from earlier or contemporary Eddystone models, there are one or two interesting ‘twists’ unique to the S.940. For example, the front-end has two RF stages: not the usual two pentodes, but a twin-triode (ECC189) in a cascode circuit (see sidebar on next page) followed by a pentode (6BA6). This ‘supercharged’ front-end, in theory at least, packs more sensitivity punch than the 830, which only has the cascode stage of similar design. The cascode arrangement is known for having the low noise factor of a triode combined with the RF stability and amplification factor of a pentode, along with a greater resistance to overload and cross-modulation. The S.940 also has variable

940

The Eddystone ‘940’ is a larger and more elaborate communications receiver, with a correspondingly better performance. It has two fully tuned radio frequency stages and two intermediate frequency stages; variable selectivity with a crystal filter; built-in carrier level meter and push-pull output stage. Sensitivity is very high and outstanding results can be expected. Workmanship, construction, and finish are all to the usual high Eddystone standards. Styling is modern with two-tone grey finish.

List price £133 0s. 0d

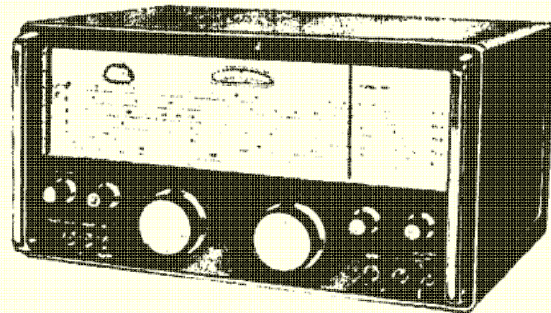

selectivity (see sidebar later in this article) and a crystal filter for the highest selectivity setting (similar to the S.640 and S.730/4) – something most of the ‘high-end’ 830 range of receivers lack (though to be honest, doesn’t really need). The S.940 also sports a product detector for SSB, a stabilized local oscillator/BFO HT line, a solid-state noise limiter and even a push-pull output stage, as per the S.770R (the 830 only has a single-ended one). All in all, not too shoddy a specification for a mid-range set!

Mechanically, the S.940 is generally typical solid Eddystone construction with only the IF cans, audio output transformer, power supply choke and the main tuning gang giving the appearance of some cost cutting when compared with its contemporary ‘professional’ models costing over three times more. Even so, my set is over 42 years old and these components seem to have stood the test of time – indeed my set has had enough wrist-twisting applied to the tuning control over the years to have worn-out the brass bearing fitted to the front panel, though the tuning capacitor gang seems to be ok. The all-important coil box, dial mechanism, mains transformer and most passive components are the same quality as the ‘professional’ sets and, although the lower-wattage resistors look to be of a marginal wattage rating, most of the bypass and coupling capacitors are the more reliable polyester or ceramic dielectric types rather than paper. One of its best features though is that, apart from a few components in the RF stages, most components are very easily accessible for servicing and repairs (see annotated layout diagrams near the end of this article) – the opposite of my S.770R’s IF/AF strip...

Wot, no eBay?

So, how did an S.940 wing its way into my hands? Well those that have read my S.750 restoration article may remember mention of an S.940 ‘parts set’ that had been donated to Pat at

The Cascode Circuit

Developed around 1950 and used in some early TV (VHF) front-ends, this circuit comprises a grounded cathode triode stage followed by a grounded grid triode stage, effectively in series – ie, *cascaded triodes* or ‘*cascode*’.

Normally, direct coupling is effected between the two triode stages with the input circuit of the second stage acting as the output load for the first stage. The need for neutralisation, otherwise required for triodes in grounded cathode RF applications due to the Miller Effect, is dispensed with because the feedback voltage through the plate to grid inter-electrode capacitance of the first stage (operating at low anode volts and low gain) is too low to cause oscillation, and the second stage, connected in grounded-grid configuration, is inherently stable. The total gain of the two stages approximates to that of a pentode, but with the lower noise characteristics of a triode and with better cross-modulation characteristics. Typical valves used in this application include the ECC189/6ES8 (as in the S.940 and S.830), ECC84/6CW7 and 6BQ7.

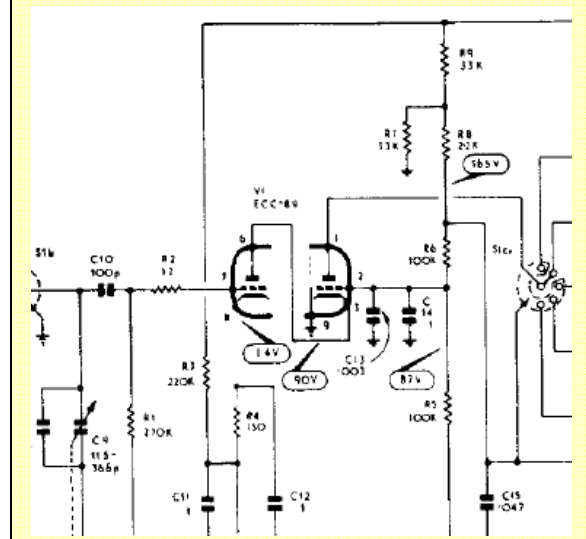

the SPARC museum – Pat needed the mains transformer to start the restoration of his S.750 – he also kindly donated a dial bulb holder and a valve screen for my S.750 from it. On enquiring why the S.940 had become a ‘parts set’ Pat noted that many experience ‘radio fixers’ had ‘had a go’ at it but it seemed to have an ‘incurable fault’ that prevented the set from working. A couple of weeks later, I had a phone call from Pat who asked if I would be interested in adding an S.940 to my Eddystone collection? I was pleasantly taken aback, especially as Pat was donating the set to me (now ex-transformer, and he had removed the BFO unit to see if he could make it work with his S.750). You bet I would! was my reply.... I picked up the set the following weekend, complete with valves and the detached BFO – thank you Pat, very much appreciated.

So, what could I do with an ex-parts set? – I think most folks would put it on the shelf and forget about it... especially if sets in better condition were more readily available as in the UK market, however in BC, Canada, I have to make the most of what I can get hold of. Anyway, I do get a kick out of breathing ‘life’ into needy and deserving radios, so, here is yet another restoration article, this time on the ‘parts set’ S.940.

Preliminary Inspection and Basic Preparation

Overall, the S.940 was not in too bad physical condition, apart from being an ex-‘parts set’ and therefore missing some bits

(the most important being its mains transformer, the L4/C4 coil/capacitor assembly, the coil box cover and, of course, its case), as well as the BFO unit being removed, though in my possession, and the B7G-mounted crystal missing from the first IF can. There was not too much grime on the chassis and no sign of overheating in the power supply area (the transformer had been ok as it was removed by Pat for his S.750) and, amazingly no signs

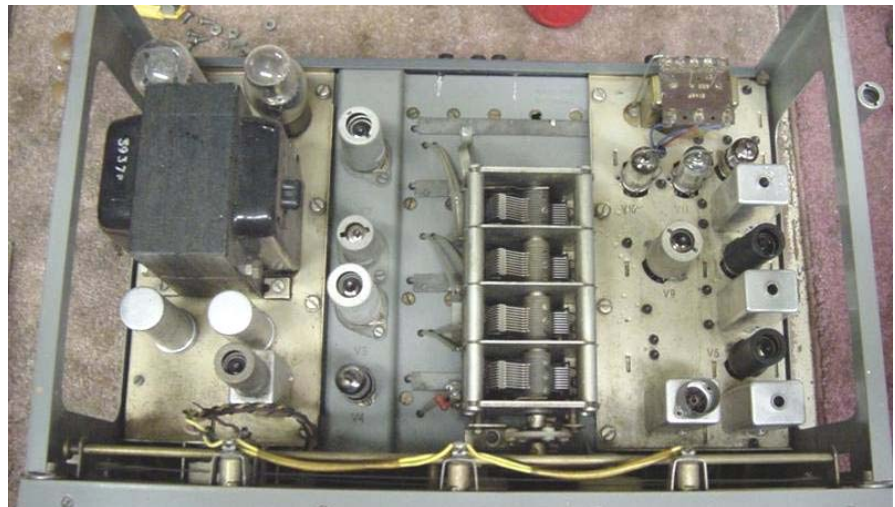

Before the mains transformer was donated to Pat’s S.750 and the BFO and dial lamp holder were removed

of the radio ever having been dropped! All the knobs were present and, apart from being dirty, the scale plate was in good shape. The finger plate was also not too bad, the main wear being underneath the Band change knob – it looked like one of the screws holding the plastic skirt of the knob in place had been loose for a long time and had gouged a channel in the fingerplate – luckily this is hidden by the knob. Physically, the main issue was that the tuning mechanism was very stiff and the circular logging scale was bent and catching badly on the front of the gearbox. This indicated that the front panel would need to be removed and dismantled (which proved to be very similar to the S.750 – see below). Beneath what grime there was, numerous paint and varnish spots were present over the chassis, indicating that the case had probably been removed for some time, and there was a number of non-standard drill holes present in the back panel.

The serial number of the set, JP0608, indicated that it was built in October, 1964, according to my interpretation of the serial number information on Alan Clayton's Eddystone website (www.qsl.net/eddystone, though this site is currently down and under revision), whereas the EUG Quick Reference Guide (QRG), page 26 method does not work (the last month code is an 'L'). The 1964 date is supported by 'Oct 63' and 'Nov 63' marked on the Plessey electrolytic smoothing capacitor cans.

So, I placed the 42-year-old on my workbench, found the vacuum cleaner and paintbrush, a digital camera, made the necessary cup of tea and started...

- Removed the valves, cleaned the glass and pins and thought I might as well test them while I was at it: one bad 6BA6 in the second IF stage and there was a 5U4G fitted in place of the GZ34 (or 5Z4G) rectifier. The 5U4G tested ok, but should not be used in this application (even though it has the same pin-out) as it takes an extra amp of heater current and has a

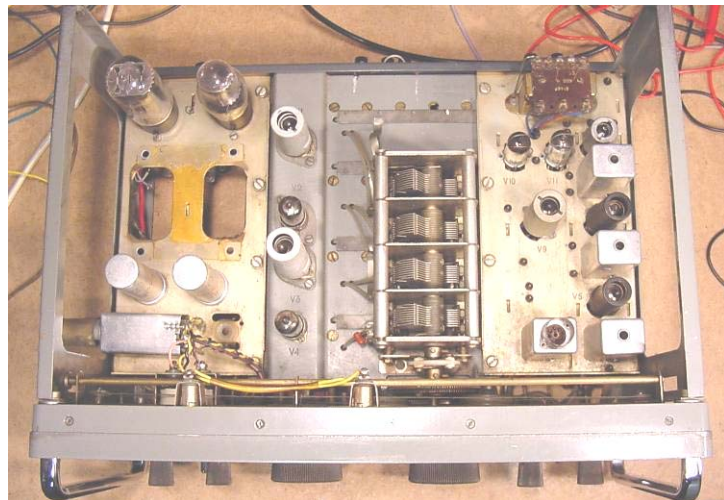

The S.940 on arrival at the G8GUH shack – spot the differences to the photos above...

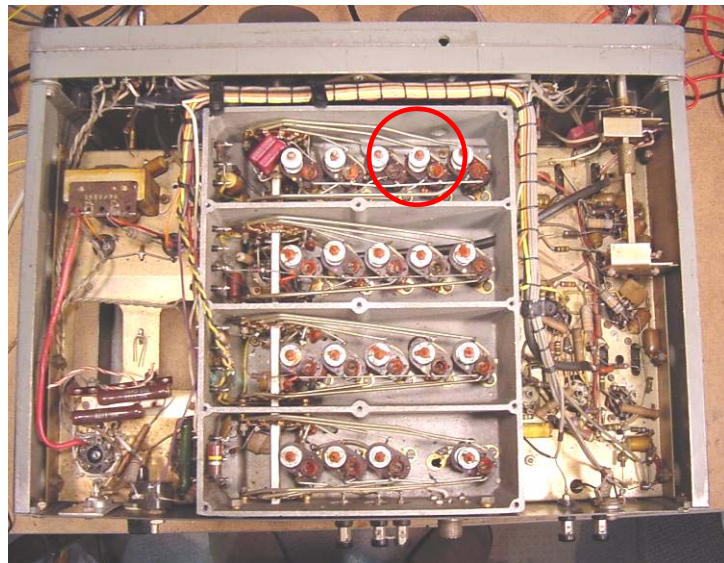

directly heated cathode – this applies the HT sooner to the rest of the receiver circuitry than for an indirectly heated rectifier such as the GZ34/5Z4G.

- Vacuum-cleaned the chassis, using the small paintbrush to penetrate nooks and crannies. A blast of air from my compressor cleaned out the tuning capacitor vanes. For now, I wiped the front panel with cotton wool wipes and warm soapy water and worked on the chassis with isopropyl alcohol (using Q-tips and cloths) to remove any grime. The coilbox is the usual trademark Eddystone aluminium casting and the power supply and IF/AF sub-chassis flanking the RF coilbox all cleaned up reasonably well. I plugged the non-standard drill holes with epoxy filler and painted them over. As noted above, the tuning mechanism was almost totally jammed, with the circular logging scale being so bent that it was catching on the front plate of the gearbox, meaning that the front panel would need to be removed and the mechanism serviced/repaired.

- Removed the knobs: the grub screws came out easily – no corrosion on them at all – good news. I noticed that all the knobs had slight splits in the sides as on my 830: not serious enough to worry about for now at least.

- Carefully removed all the retaining nuts from the controls using a Teflon scratch guard (see photo below) and prized the fingerplate away from the front panel casting. It was fixed at the centre using double-sided tape, the residues of which were carefully scraped away. Removed the small screws holding the BFO and crystal phasing controls in place.

- The fingerplate was generally in good condition apart from the scoring beneath the band change switch noted earlier. I decided to just touch-up the scored area for now rather than attempt a more thorough repair (the scored area is hidden by the knob anyway).



BFO unit on arrival – all present and correct but a bit detached (like me?)

Removing and Replacing the Front Panel and Drive Mechanism



Removing the controls – note the oversized scratch guard

- Removed the dial glass by taking out the bolts holding the small cheek castings in place either side of the dial glass, along with the four screws holding the dial lamp mounting plate in place at the top of the front panel. Once these are

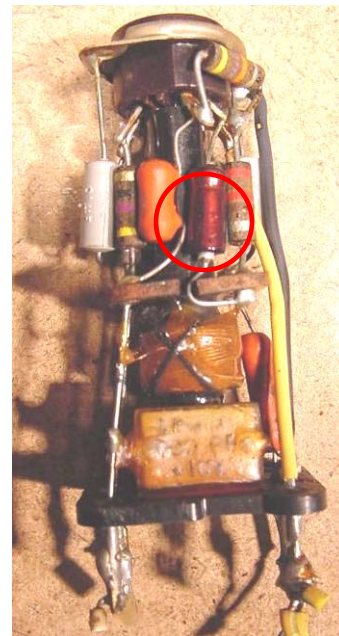

Inside the BFO unit – note C100 (10uf electrolytic) lurks in here (circled)

removed, the dial glass can be lifted out easily (note: this can be done with the rest of the radio in place to clean the glass and dial plate as part of routine maintenance).

- The dial drive mechanism is remarkably similar to the S.740 that I had repaired a few weeks earlier, with the exception of the method of drive tensioning – here a spring-wire loaded jockey pulley, is located on the left plate (looking from the rear) supporting the pointer guide rods, rather than the pivoting coil-spring loaded arm on the right hand side as in the S.750.

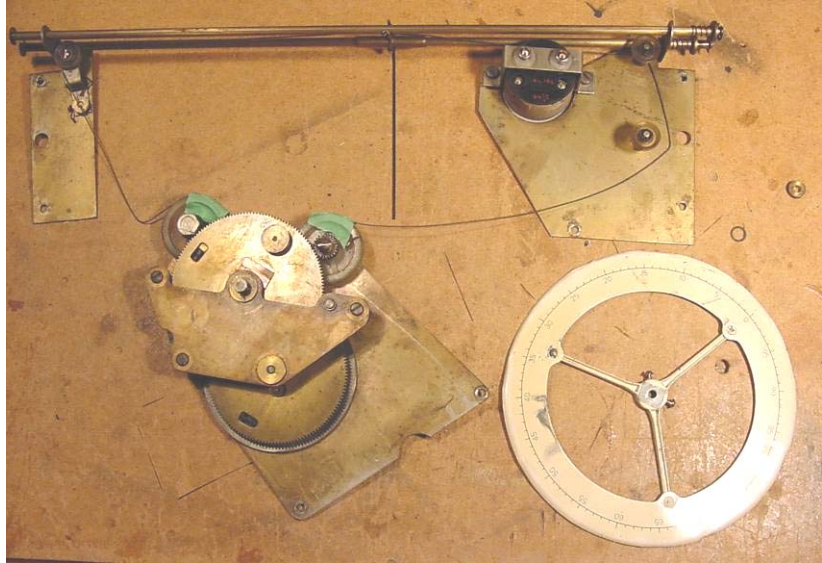

- I took several photos of the tuning drive mechanism from all angles for reference. The drive cord looked in reasonable condition, so I decided to leave it fixed to the spool pulleys at either end and to remove the assembly intact – hoping that I would not have to re-string the dial (see EUG Newsletter #25, p17 for tips on this if you have to do it).

- Loosened the grub screws in the flexible coupler on the tuning capacitor. Removed the four outer front panel retaining bolts and spacing washers and took the chrome handles away. Removed the four inner front panel retaining bolts (these are removed from the front and are exposed once the finger plate is off). Pulled the front panel casting away, complete with the dial drive mechanism.



Gearbox in my bench vice for cleaning (note dial cord still attached and threaded through idler and jockey pulleys)

- I approximately centered the drive and prevented the cord from leaving its grooves on the toothed spool pulleys using two small pieces of masking tape (see photos above, left and on the next page). Careful inspection of the gearbox revealed that nothing was binding or blocking movement of the gears and that the stiffness was due to gummed-up bearings and teeth (age-solidified 3-in-One oil as per previous experience I would hazard a guess). There was little wear on the brass gears and no damage was noted on the plastic toothed spool pulleys (damage here is noted as a common problem due to rough handling and over-enthusiasm when spinning the tuning knob when suddenly the drive cord

breaks and jams in the gears).

- Loosened the three screws holding the gearbox to the front panel casting, tipped it forwards and upwards slightly and the gearbox was then removed with the dial cord intact.

- Removed the two plates supporting the pointer guide bars: two screws on the left, three on the right – note that the lowest of these three has a brass spacer between it and the panel casting to give the correct clearance for the dial plate - and then pulled the tuning knob spindle out of its brass bushing.

- I removed the round logging scale (vernier) dial plate from the gearbox front spindle (photo right) and placed the gearbox into a smooth-jawed bench vice and then painstakingly cleaned each tooth on each gear and pinion using isopropyl alcohol, a darning needle and Q-tips. I used lighter fluid to remove the more stubborn ‘gum’ and clean out the bearings. I found

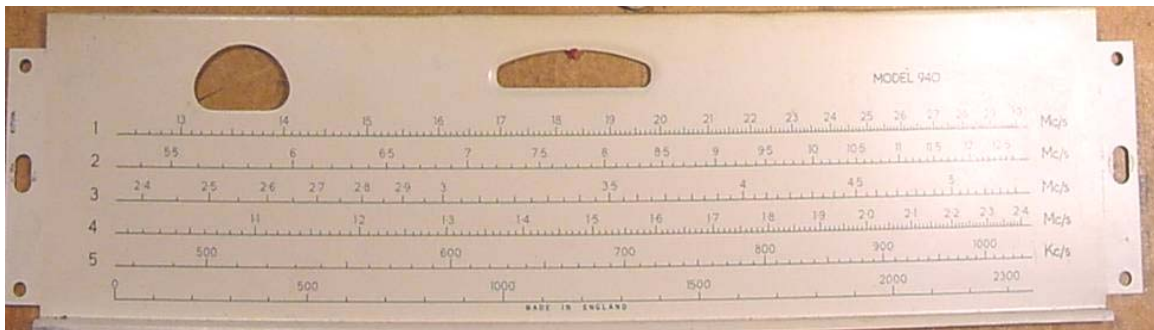
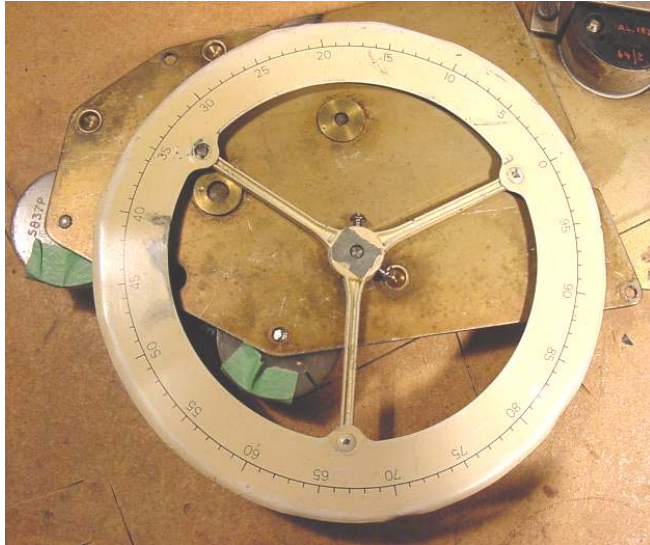

Vernier scale and main dial plate – the former looking a bit sad before cleaning...

that the gears were now freely-turning and I decided not to dismantle the gearbox totally, but to apply a light coating of high-quality light machine oil (not 3-in-One!) to each of the bearings and a smearing of molybdenum (‘moly’) grease to the parts of the brass gears that did not mesh with the plastic spool pulleys. I tried it out – much smoother now. The friction drive plate was cleaned using lighter fluid to remove any stray oil or grease, as was its mating surface on the tuning spindle.

- Cleaned the dial glass, dial plate and vernier dial using warm soapy water and cotton wool – these have very delicate markings (so be very gentle) – see photo above. The round vernier scale is constructed from a thin aluminium pressing attached to an alloy casting bushing and spokes. The metal pressing was very distorted and a considerable amount of care was exercised in trying to reproduce its original form (careful bending between fingers and checking by placing on a flat surface many times until it was deemed ok). Luckily most of the catching had been between the rear of the vernier dial and the front gearbox plate, thus preserving the vernier scale markings intact.

- Cleaned-up all the remaining drive components (idler pulleys, guide rails etc) and re-assembled the drive mechanism to the front panel casting, simply reversing the disassembly order.

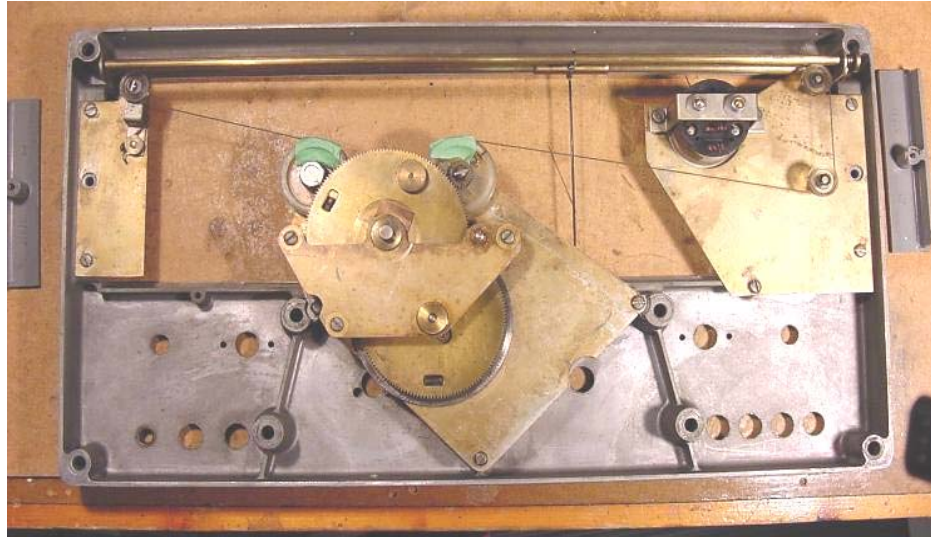

- Applied a little moly grease to the guide rails.

Front panel and dial drive mechanism after cleaning and re-assembly

- The tuning knob shaft was coated with moly grease prior to installation in its bushing, though I noted that the fit was a bit loose (the brass bushing was quite worn). The tuning knob was then fitted and the completed assembly tested for that sensual ‘Eddystone smoothness’ – it was there, but when spun rapidly the worn brass bushing showed itself by causing a vibration – that would need to be addressed in the future (see Postscript). Now for the mechanical reassembly and the electronics, thinking that the latter would be a challenge with no functional power supply in the set – nothing ventured, nothing gained I suppose...

Mechanical Re-assembly

- I decided to start work on the electronics with the front panel still removed as this made access to underneath the chassis front much easier: useful if one or more of the gain controls, BFO/crystal phasing variable capacitors or panel switches needed to be replaced or serviced.

- Installed a quick-blow in-line fuse in the wiring for the HT centre tap of the mains transformer (though the transformer is still missing at this point), complete with a 200mA slow blow fuse. Also, I installed a 2A fast-blow fuse in the chassis-mounted fuseholder wired into the mains transformer primary (it had a 5A fast blow installed on arrival).

- Checked the general electrical safety of the psu unit – someone had replaced the original ‘kettle connector’ with a horrid and flimsy-looking two pin chassis-mounted plug screwed to a piece of aluminium. I decided to replace this with the Euro-connector conversion as described in my S.830/4 and S.770R articles. This done, I proceeded to check for poor connections, heat damaged wires, poor insulation etc. as well as trace the loose wires left hanging when Pat had removed the mains transformer.

- The RF and AF gain pots both looked original and tested ok after cleaning with De-oxid, and all the switches checked ok. The BFO and crystal phasing variable capacitor bushings were also cleaned with ‘De-oxid’.

- Then I re-attached the front panel to the chassis. This is easier said than done, as getting all the switches and other controls into the correct holes at the same time takes some doing! A tip to help with this (that I meant to mention in the S.750 article) is to temporarily stuff the space beneath the switches and other controls with some packing material (see photo right) – this simple expedient holds all



the controls in place while you fit the retaining nuts (saves a lot of time and cursing).

- Re-attached the front panel by reversing the disassembly routine: insert the four centre bolts attaching the coilbox, insert the screws fixing the BFO/Phasing variable capacitors, then temporarily mount the finger plate using two strips of double sided sticky tape, and then insert the four bolts attaching the chrome handles (don't forget the spacing washers between the chassis side panels and the front panel).

- Re-fitted the dial glass, side cheek castings and dial lamp/scale glass retaining plate.

- I then fitted the replacement dial lamp holder (made originally for my S.750 to replace a bodged screw-thread one) and fitted new long-bulb #47 dial lamps – a standard in US and Canada radios – its ok to use them here as in this set the extended glass bulbs do not interfere with the drive cord.



- Next, I re-fitted each of the control retaining nuts, taking care not to gouge the fingerplate. I used a small home-made 'washer' made from Teflon baking sheet (ex-kitchen) to do this with a regular pair of pliers.

- I then cleaned the main tuning capacitor contact 'fingers' using 'De-Oxit' on the rotor contacts and re-packed the ball bearings with moly grease.

- Replaced the knobs and tightened the flexible coupling grub screws on the tuning gang shaft, having positioned the scale and the gang rotor at the same end of the travel.

- With all valves still removed, I started to undertake some electronic checks... see pages 24 and 25 for component layout diagrams and also the circuit in the attached manual.

Electronic Testing, 'Jump-Starting' and Repairs

- First the obvious: re-fit the BFO unit. Not too difficult as Pat had left short pieces of the wires on the base pins that could be matched with some of the ones hanging in the radio.



First I removed the can from the BFO unit and did some cursory component and pin-out checks before refitting it to the chassis and re-wiring into the circuit. While I had the opportunity I checked C72 (metallised paper heater decoupler) and found it to be leaky – replaced it (blue capacitor in photo, left).

- Next up was investigation of the cause of a disintegrated resistor (R9, 3.3kohm) – see photo below – feeding HT to the cascode RF stage (V1). I suspected a component(s) further down

the voltage divider chain of resistors, possibly a short circuit capacitor (C13, C14 or C15 were suspect). C15, a 400vw 0.047uf polyester, hidden twixt the end plates of L6 was found to be ok. C14 however, a 200vw 0.1uf plate ceramic, tested short-circuit (very unusual in my experience for a ceramic capacitor to do this). Some resistance measurements during dismantling confirmed that R7 was ok, but R5, R6 and R8 were out of tolerance (R5 way high at almost infinity, R6 low at 12kohm and R8 short-circuit: this could explain why C14 failed (excess voltage).

Replacement of some of these components is easier said than done (though see Lighthouse issue 78, page 42 by Graham Wormald for some tips) as they are buried in the deepest recesses of the coil box, beneath the band change switch shaft and a divider cast into the box (see annotated photos below). I temporarily removed components above the valve base to

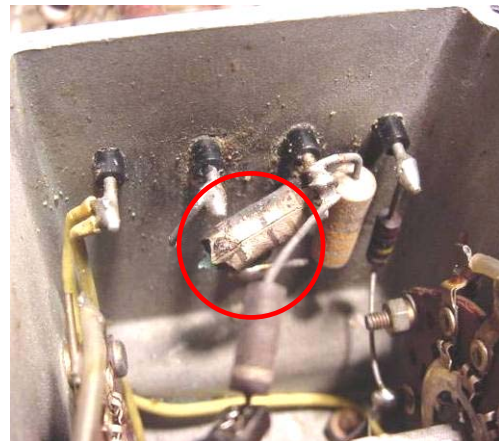

Burned-out R9 (not) feeding HT to V1

clear some room, but decided to leave the band change switch shaft in place, use a pencil soldering iron and to do some pre-assembly of the new parts (apparently some of these components were pre-mounted on the valve bases and then dropped in through the top of the casting as the first step in assembly at the Bath Tub, with all the remaining components then being added around them from beneath). I used over-rated (1w) resistors for the two 100kohm units (R5 and R6) for stability and longevity. Graham suggests that R5 and R6 can be connected to the 'cold' ends of L6 (terminals nearest the valve socket), but I did it the hard way and replaced them in their original locations. I used a Mylar replacement for the shorted-out C14 and a polyester replacement for C13 (the original C13 component was low leakage but also very low capacitance).

- Although the set should work ok without the phasing crystal (except on the 'crystal' selectivity position), I decided to try to locate one – although I had little success in finding the exact type (a 450kHz B7G socket, type JCF/193), I did find a 455kHz HC6U base crystal in my junk box, along with a genuine McMurdo base. I soldered two stiff wires onto the base to form an adapter and pushed it into the B7G crystal socket (pins 1, 2, 3 are connected to one side of the selectivity switch and pins 5, 6, 7 are connected to the other, pin 4 is not connected). I pushed the crystal/adapter into the B7G socket (photo right) and placed a valve screen over the top to form a look-alike replacement.



Of course I needed to re-align the IF in the set to 455kHz in order to use the crystal.

- In the absence of a power transformer, I decided to undertake a few resistance/capacitance checks of selected components reported by others or known by myself to give trouble, including the AGC line capacitor, C81, another 0.1uf plate ceramic (ok), C82 (ok), R35, R36, R37, R38 (all four replaced) and RV2 (ok) in the S-meter circuit (screen of V6), R72, R73, R74, R75 (all ok) in the power supply, R43 and R44 in the AGC diode circuit (both replaced), R57, R58, (both replaced), R62 (ok) and C103 (leaky - replaced) in the first audio/phase-splitter stages, R61, R63, R64, R65, R66 and R67 (all ok) in the push-pull output stage, and the noise limiter diode D1 (ok). C90 was also replaced (low capacitance), as were R28 and R39 in the IF amplifier stages and R5, R6, R8, R9, R14, C13 and C14 in the RF stages (the mixer and oscillator stages were ok).

- Checks on C102 and C106 ('Plessey' audio stage cathode by-pass electrolytics) indicated typical high leakage and low capacitance, so these were both replaced also.

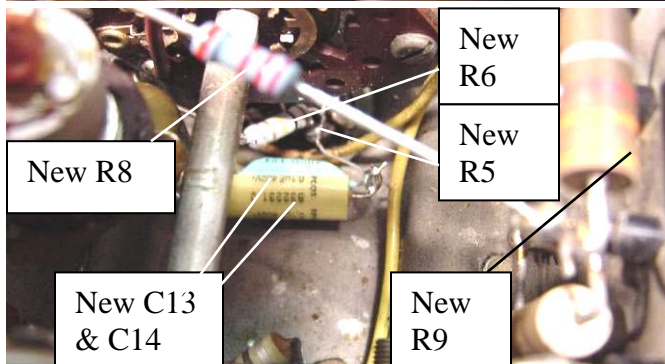
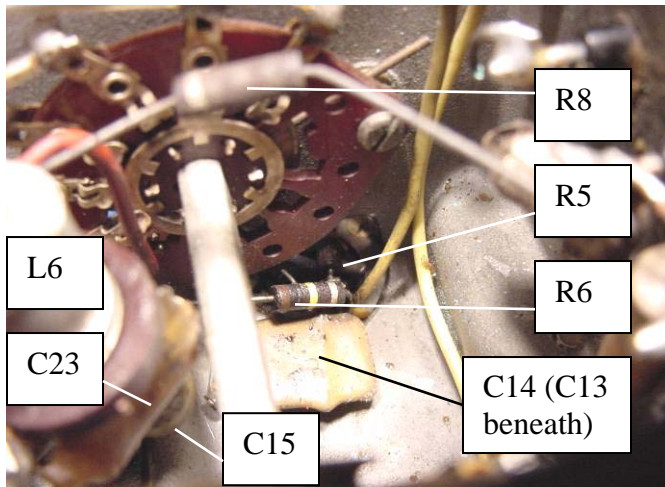

- Resistance checks on the psu filter capacitors (C108 and C109) indicated that they were leaky: these would need to be either replaced or re-formed once I was able to apply power.

- Undertook leakage checks on a few of the IF and mixer stage by-pass capacitors - all appeared ok.

- By this time I was getting more than a little frustrated at not being able to power-up the set.

- Drastic action was needed – so I decided to use another Eddystone as a temporary power supply – my S.770R was handy and has a similar power supply circuit and the same model of power transformer. I unplugged the octal plug from the rear of the S.770R

V1 valve base showing original component locations above and new components below

(this disconnects all the 6.3v heater circuits except for its noise limiter valve, V10 - this being fed from a separate secondary winding, so V10 was removed). I then installed a thick ground jumper between the two receiver chassis and jumpers from the S.770R's rectifier (5Z4) cathode (HT) to the input of the HT choke in the S.940 (also disconnecting the S.770R's choke) and from the 6.3v heater transformer winding in the S.770R to the heater supply bus in the S.940. All these temporary leads were soldered in place, insulated where needed and securely held with cable ties. I installed the stabilizer valve (OD3/VR150) in the S.940 and temporarily disconnected the S-meter as it would be really imbalanced with no valve (V6) in place and could therefore possibly be damaged, plugged the S.770R into my variac and....

- Power at last! A bit of a lash-up I admit, but at least I could now test some of the circuits with power applied pending sourcing a suitable transformer.

- First, the HT smoothing capacitors were re-formed over a several hours by slowly increasing voltage from the variac, monitoring the HT current draw (all valves apart from the stabilizer still removed in the S.940) - increasing the voltage in stages, holding for up to an hour and also switching off/on a couple of times at each stage. As current draw fell off at each voltage increment, I increase the applied voltage by 25v, up to the full HT volts of ~250v. The OD3 lit up at just over 150v and it held steady at 149v. Leakage current at the end of re-forming was acceptably low on all the smoothing capacitors.

- Cleaned up each of the valve sockets in the set using 'De-Oxit'.

- Re-installed the remaining valves and attached a speaker and output meter. Slowly brought the S.940 up on the variac over around 15 minutes, checking the HT

Selectivity Control and the Crystal Filter

Having an appropriate level of selectivity is, to a degree, more important than high sensitivity in a communications receiver – what is the use of a receiver picking up a signal if it cannot be separated from others nearby? The S.940 benefits from having a three-position control (S2) such that the operator can choose the selectivity needed for the particular mode of operation. On 'min', an extra degree of coupling between the primary and secondary windings of IF transformers T1 and T3 is introduced into the circuit, via 'tertiary' windings. This position is suitable for AM broadcast reception when little adjacent channel interference is present). When switched to 'max', this over-coupling is only applied to T1. This position is suitable for SSB and AM broadcast reception when adjacent channel interference is present. The S.940 is also fitted with a single crystal filter between T1 and T2. The crystal (XLT on diagram below) is shorted out so that it is inoperative in both the 'min' and 'max' sensitivity positions. In the 'crystal' position, all over-coupling is removed from the IF transformers and the crystal is allowed to resonate. This position is especially suitable for CW reception. The 'crystal phasing' control, C68, allows the adjustment of the crystal's peak/rejection notch by cancelling out (to varying degrees) the capacitance of the crystal holder. There is a 'Technical Short' on this topic for those interested in reading more.

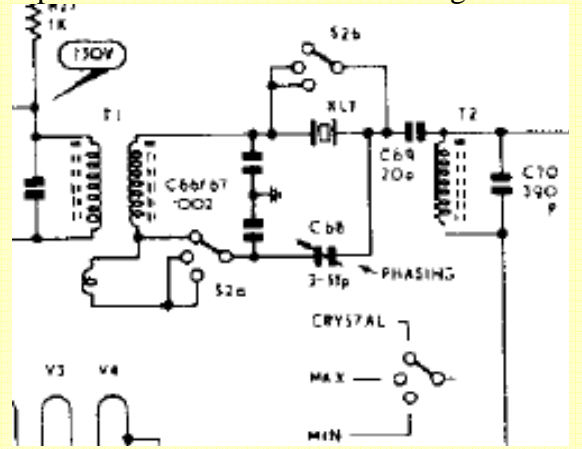

current draw (transformer secondary fuse removed and the fuseholder bridged with a millimeter) - about 125mA at our nominal 117v AC power applied to the 110v tap on the S.770R mains transformer. At 110v set on the variac, the S.940 was still drawing 115mA (the manual does not specify a typical current draw, but 115mA to 125mA seemed on the high side, especially as the mains transformer type 3937P is only rated at

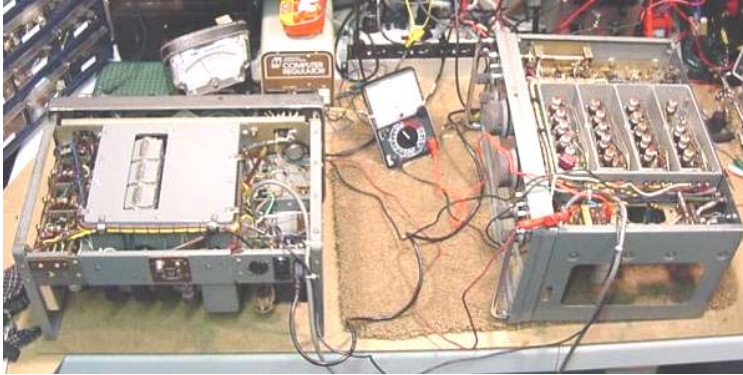

110mA HT and the 5Z4 at 125mA. I backed-off the applied AC voltage to give a current draw of 110mA (this being at about 105v AC), resulting in an HT2 voltage of only 225v.

- No signals could be heard, but I could hear a slight hiss/intermittent crackle and when I injected an audio signal (finger) at the AF gain pot slider this resulted in an

‘Jump-starting’ the S.940 with my S.770R...

encouragingly loud buzz from the speaker – at least the audio stages were working.

- Checked key voltages against those shown on the circuit diagram using the specified 20kohm/volt meter – most were within tolerance (allowing for the slightly low HT voltage), but some were out by a fair amount, eg. the screen voltage of V5 was reading around 125v (should be 110v). Also, the S-meter would not quite zero (odd, as all it’s associated bridge resistors had been replaced, voltages on V6 were normal and C82 checked out ok). I noted that the RF gain pot varied the cathode volts on V1 from 1.4v to 25v (seemed ok) and this also reduced the set’s current draw to 95mA at the lowest gain setting. Switching the set to ‘standby’ had a similar effect on the set’s current draw. I decided to leave things as they were for now and check to see if the set was actually functioning as a receiver...

- I tried injecting an IF signal (the standard 450kHz) into the grid of the final IF stage, yep, this was heard ok, same for the first IF and mixer stages. With the band switch still set to Range 5 (as required for the voltage checks), I set the receiver to 600kHz with the signal generator coupled loosely to the aerial connector – a signal was heard when tuning across the 600kHz marker of the signal generator (it kicked up the S-meter well past half-way). Encouraged by this, I coupled up an aerial and heard several local stations whilst tuning across Band 5. I did notice that the signals were a bit ‘thin and edgy’, perhaps indicating poor alignment of the IF stages. Band 4 was fairly ‘dead’ but with some hiss (L4/C4 missing), but there were some faint signals on Ranges 2 and 3, though Range 1 was very quiet.

- Checked the AGC voltage on a strong signal from the genny applied to the aerial input: no more than -2v of AGC control voltage could be measured on my VTVM (many sets can attain -6v to -12v on a very strong signal and even for a set with this much available gain I thought -5v would be more typical). As the S-meter, connected to the screen grid of the 2nd IF stage (V6), was showing almost end-stop, this suggested to me that something was not right in the AGC detector circuit (V7a) – I decided to check this out further once the set was at least in a modicum of proper alignment.

- I tried the BFO – this appeared to work well and all of the other controls seemed to work ok except for the ‘crystal’ position on the selectivity control (not surprising as the crystal was a nominal 5kHz off the standard IF frequency and I was not certain if the crystal was still active anyway – I probably bought it off a rally stall as surplus over 30 years ago!).

So, with the sets ‘mechanicals’ working ok except for the ‘rumble’ caused by the worn driveshaft bushing (see Postscript) and its ‘electricals’ working, hopefully well enough to try a preliminary re-alignment (even if it was relying on an S.770R for its power), I reached for my red *101 Dalmatians* box of assorted ‘real’ trim tools and trusty whittled-down plastic knitting needles (can be seen at the top of photo above)...

Preliminary Re-Alignment



Temporary bridging cap in Band 4 aerial circuit

- As noted, the set was a bit ‘deaf’ on all bands at this point, with only signals from known local very strong stations producing movement on the S-meter, so I decided to do a full re-alignment – this would be needed anyway due to the non-standard crystal filter frequency. Before I started, I ‘bodged’ the RF coupling to V1 on Band 4 by temporarily installing a 470pf capacitor between the wires hanging in the aerial input section of the coil box where the L4/C4 combo had been removed. Closer inspection of the IF transformer and coilpack dust cores (‘slugs’) and ‘beehive’ concentric trimmers showed signs that they had been played around with as most of the red wax seals were broken (where unbroken, the wax actually looked to have been

applied professionally, though I don’t know if the Bath Tub did this – see photo below).

- The IF re-alignment procedure as detailed in the manual was followed to the letter, but with the signal generator set for approx 455kHz (instead of the standard 450kHz for the S.940) to allow the non-standard 455kHz crystal to be used. I first tried injecting a 450kHz signal and noted that most of the IF slugs were significantly ‘off’, especially T1, indicating these had likely been ‘twiddled’ in the past. On injecting a nominal 455kHz, the crystal was found to be working ok and the IF stages, crystal filter and BFO tuned up nicely to their new frequency - now for the RF stages.

- First the oscillator section (nearest the front panel). Again, I followed the instructions in the manual to the letter, using a crystal calibration marker to supplement the 1950’s valve RF genny and 1980’s digital frequency meter combination I was using. As I understand that the LO on the S.940 should always track above the signal frequency, it is useful to remember that *‘if the oscillator frequency is higher than the received signal, the lower-frequency position on the signal*



Hardened red sealing wax on the concentric trimmers and coil slugs

genny dial or the higher frequency position of the receiver dial is identified as the proper signal at which to align' (Radio and Television Receiver Troubleshooting and Repair, Ghirardi & Johnson).

- During adjustment of the iron dust cores (for low-frequency settings), I first scraped off the hardened red wax covering the ends of the cores sufficient to allow the core to be turned. Fortunately all the cores were found to be in reasonable shape despite a 'twiddler' having 'had a go' at some time(s) in the past. Adjustment of the 'beehives' (high-frequency settings) was straightforward. Only two iterations of adjustments on each range produced good scale linearity.

- The S.940 now had good sensitivity and selectivity on all bands (Band 4 with the bodged aerial circuit was not quite as good – some cross modulation and interference was noted that likely would not be there with a tuned input to V1 on this band).

- Still only around -2.5v of AGC voltage measured on the VTVM on a strong signal that hard-stopped the S-meter. I checked around V7a again: the cathode was right on the desired 45v. I changed-out the 6AL5: no difference. I disconnected C88 (a 50pf tubular ceramic) that applies IF from the anode of V6 to V7a anode – it was ok (63pf and no leakage). Re-checked R41 and R42: both ok. Staring at the component layout in disbelief, I noticed that the (bare) lead of C88 was pushed hard against the case of C82, a 0.047uf polyester bypass capacitor on the screen of V6, and the plastic film coating the capacitor sleeve had been breached at that point (light dot circled in photo right). I separated the two and the AGC voltage jumped to over -5v, indicating that although it was not forming a low-resistance short (as there was still correct voltage on the anode of V6), there had been sufficient coupling between the lead of C88 and the C82 sleeve to affect the AGC voltage – a strange fault indeed...

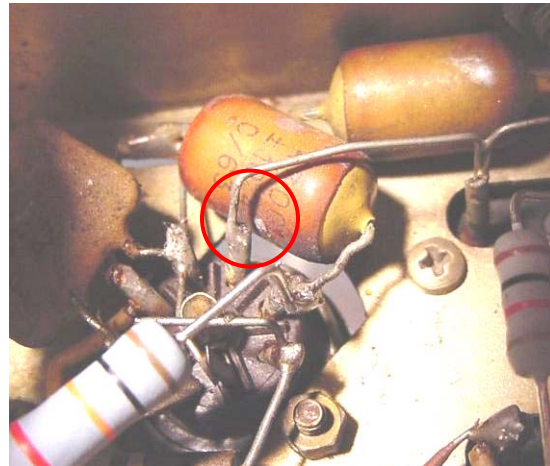

Lead from T4 secondary/C88 where it was pressed hard against the case of C82 (note small 'bare' spot' where it had been resting)

Conclusion (almost)

I left the set on 'soak' test for a few hours and tuned around the bands – pretty impressive! I re-checked all the key voltages as listed in the manual following some prolonged use of the set and they were all found to be within tolerance when the HT1 line was adjusted to the specified 240v using the variac. I noted that the set was now drawing around 95mA on standby, 105mA when a strong signal was applied and up to 115mA under no signal conditions (a little more when set to Bands 1 through 3). Also, with 120v AC applied directly to the S.770R supply, the HT1 line was at 255v and the current draw was 125mA with a strong signal applied. I figured that although the current draw still seemed high, it could conceivably be normal, especially as all the key voltages checked out ok. Once the 'real' power supply is fitted and working in the S.940 I will re-visit this issue (note: the S940 power supply has two 140ohm resistors fitted to the mains transformer HT secondary, feeding

the rectifier anodes, that are not present in the S.770R supply. These should reduce the HT2 voltage by around 15v, which may help).

Having made a Perspex case for my S.750 so the innards can be seen while the set is working, I am contemplating making a similar case for the S.940 (though the innards are not quite as pretty). I could of course use the case off my S.830 for 'special occasions' (photos), though it is a difference style to that used for the S.940, the latter having only side perforations, whereas that for the S.830 has both side and top perforated sections.

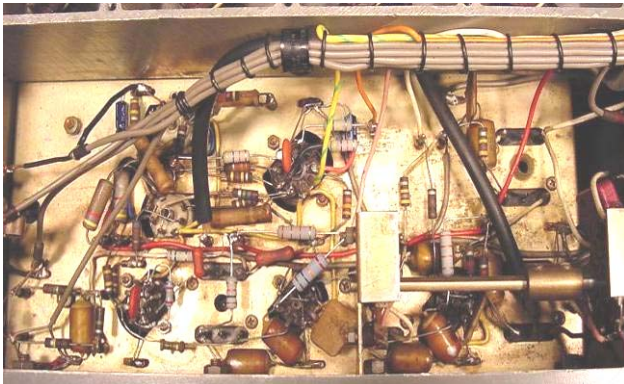

The IF/AF chassis during component replacement (annotated photo at the end of the article, Page 24)

Not having a case, for now I settled for an external cosmetic job of simply cleaning all the knobs (with alcohol) and polishing them with household silicone-based polish ("Armor-All" plastic polish for car interiors can damage ABS-type plastics, which I think these knobs may be), touched up the one or two small scratches and the tiny wear patch on the finger plate using Humbrol enamel paints mixed to match – the results looks ok (the main wear/scratched area is hidden behind the Band Change switch anyway).

So, I am now the proud possessor of a piece of very functional early-1960's HF thermionic magic that was another 'dream receiver' of my youth - thanks to Pat's generosity, a little sleuthing and a few bucks worth of bits – just the transformer to sort out now: I hope the one from Pat's 'parts set' S.750 is ok or can be re-wound at a reasonable cost. If not, I will likely fit a new 'look-alike' from Hammond. **Part 2** of this article (which I think will be much shorter) will cover the rebuild of the power supply section (once I have a suitable transformer), repairs to the Band 4 aerial section, further checking and adjustments, final 'sprucing-up' and, hopefully, 'boxing-up'.

So folks, once again I am on the look out for yet another challenge.... wonder when that S.640, S.680X, S.730/4, S.888 or other magical Eddystone classic will appear wanting some TLC? I hope this article was of some interest to EUG folks and that others will be encouraged to contribute to the ever-growing EUG website in this way (remember to always keep your camera handy when fixing stuff) – the records you keep are useful for reference when wondering how something went together, but also to illustrate articles like this – a picture is definitely worth a thousand words... I would be pleased to discuss this article or any other radio-related topics with EUG folks, either by email, the EUG forum or phone (I am on 'Skype').

73's

Gerry O'Hara, G8GUH (gerryohara@telus.net), Vancouver, BC, Canada, November, 2006

EDDYSTONE

Postscript

I called Dave Simmons and he is able to supply a few still needed (Eddystone-specific) parts, including a new brass tuning shaft bearing (he had some of these machined), dial lamp holder and L4 coil (or similar). These will be fitted on arrival, as will a transformer (whether it is a re-wind or new one) and some form of case fitted (hopefully a 'real' one) – look out for Part 2...

References

EUG Newsletter/Lighthouse (from 'Super Index')	Issue	Page
acquired by member (David Fletcher).....	86.....	28
advertisement.....	32.....	26
.....	34.....	24
(Webb's Radio, 1962).....	78.....	24
.....	95.....	40
.....	95.....	41
a.f. gain pot failure.....	24.....	2
AFVs, used in.....	51.....	4
alignment, sweep generator.....	72.....	35
audio		
crackle.....	25.....	14
gain increase mod.....	31.....	9
output distorted.....	13.....	6
.....	29.....	10
.....	19.....	17
.....	24.....	2
avc		
fault cured.....	58.....	25
poor.....	24.....	2
bfo 'popping'.....	19.....	5
bulbs.....	4.....	2
cathode vaults low.....	10.....	14
cascode problems resolved.....	78.....	42
coil former fault found.....	73.....	4
ceramic filters, fitting of (not!).....	33.....	4
comparison, Realistic DX394.....	70.....	17
component failure.....	49.....	28
condenser		
electrolytic, failure.....	18.....	10
overheating.....	8.....	19
crystal calibrator, modifying for.....	7.....	2
.....	7.....	13
.....	24.....	17
.....	26.....	1
deafness.....	32.....	22
cured.....	72.....	13
development history.....	95.....	39
dial light mod.....	24.....	2
drift & heating problems.....	79.....	34..

EUG Newsletter/Lighthouse (from ‘Super Index’)	Issue	Page
early sets, differences	45.....	3
.....	47.....	19
.....	46.....	3
eBay	86.....	26
.....	94.....	13
.....	88.....	23
faults		
common	6.....	11
finding.....	62.....	40
one member’s set.....	7.....	5
featured receiver	2.....	7
fuses, terminals corroded.....	41.....	13
gain, lack of	30.....	5
.....	52.....	29
h.f. suffix model.....	29.....	11
.....	32.....	5
.....	71.....	11
history of one set (Peter Lankshear).....	70.....	6
improvements suggested (G8POO).....	75.....	40
comments on foregoing improvements		
G8POO	78.....	24
Peter Lankshear.....	76.....	32
Ross Paton.....	78.....	6
instability problems.....	77.....	42
in-depth article with graphs (Graeme Wormald)	78.....	27
comments on, Terry Parker (Eddystone Chief of Test)	78.....	34
in use		
G.E.W. Hewlett.....	56.....	13
Ray Howgego.....	56.....	13
microphony	18.....	8
MoD version	31.....	1
origins of	79.....	35
output, lack of.....	15.....	2
output transformer, substitute.....	21.....	8
phone jack, oxidation.....	86.....	22
purchased in Scotland (Brian Abrams)	50.....	26
.....	52.....	33
ranges not working	77.....	14
refurbishment		
Graham Sutton	92.....	13
Ted Moore.....	71.....	12
repairs	48.....	16
.....	60.....	38
notes (Roger Bebbington).....	68.....	39
resistors		
high	8.....	19
burnt out.....	10.....	16
problems	23.....	7
.....	74.....	14
replacement	25.....	18
.....	29.....	10
.....	64.....	63
restoration	14.....	15
Geoff King	56.....	18

EUG Newsletter/Lighthouse (from ‘Super Index’)	Issue ...	Page
S meter problems	54.....	5
selectivity, poorer than 680	43.....	28
sensitivity, lack of	17.....	6
servicing	12.....	16
(Graham Leese)	12.....	25
specifications & info.....	85.....	12
sqelchfitted	8.....	9
.....	12.....	12
stenode modification	56.....	12
taken to school (Ted Moore)	74.....	8
transformer, winding.....	12.....	14
tuning		
mechanism.....	26.....	2
ratio	12.....	1
valve seating problem	63.....	35
variants	54.....	13
/1		
Variant with crystal controlled channels added.....	79.....	14

Web:

<http://www.eddystoneusergroup.org.uk/> (the best – of course!)

<http://bama.edebris.com/manuals/>

<http://www.radau5.ch> (excellent source of valve info (downloadable pdf’s – see the ‘dir_coup’ pdf file for a full technical description of cascode amplifiers)

www.qsl.net/eddystone (hopefully back on line soon)

Some Useful Books on Radio Circuitry and Repairs:

- Radio and Television Receiver Circuitry and Operation, Ghirardi and Johnson, 1951
- Radio and Television Receiver T’ shooting and Repair, Ghirardi and Johnson, 1952
- Electronics One-Seven, H Mileaf, 1967
- Radio servicing: Theory and Practice, A Marcus, 1948
- Radio Receiver Servicing, JT Frye, 1955
- Elements of Radio Servicing, Marcus and Levy, 2nd Ed. 1955, (the first edition of this book can be downloaded in pdf format from http://www.archive.org/details/Elements_Of_Radio_Servicing)



Bag of duff parts removed from my S.940... any offers?



‘Euro-connector’ mains connector now fitted (not much use at present!)



The S.940 looks pretty good from the front – I would say as good as my S.830/4 anyway. Here it is pulling in ‘Coast to Coast AM’ on 1410kHz @ 5-9+.

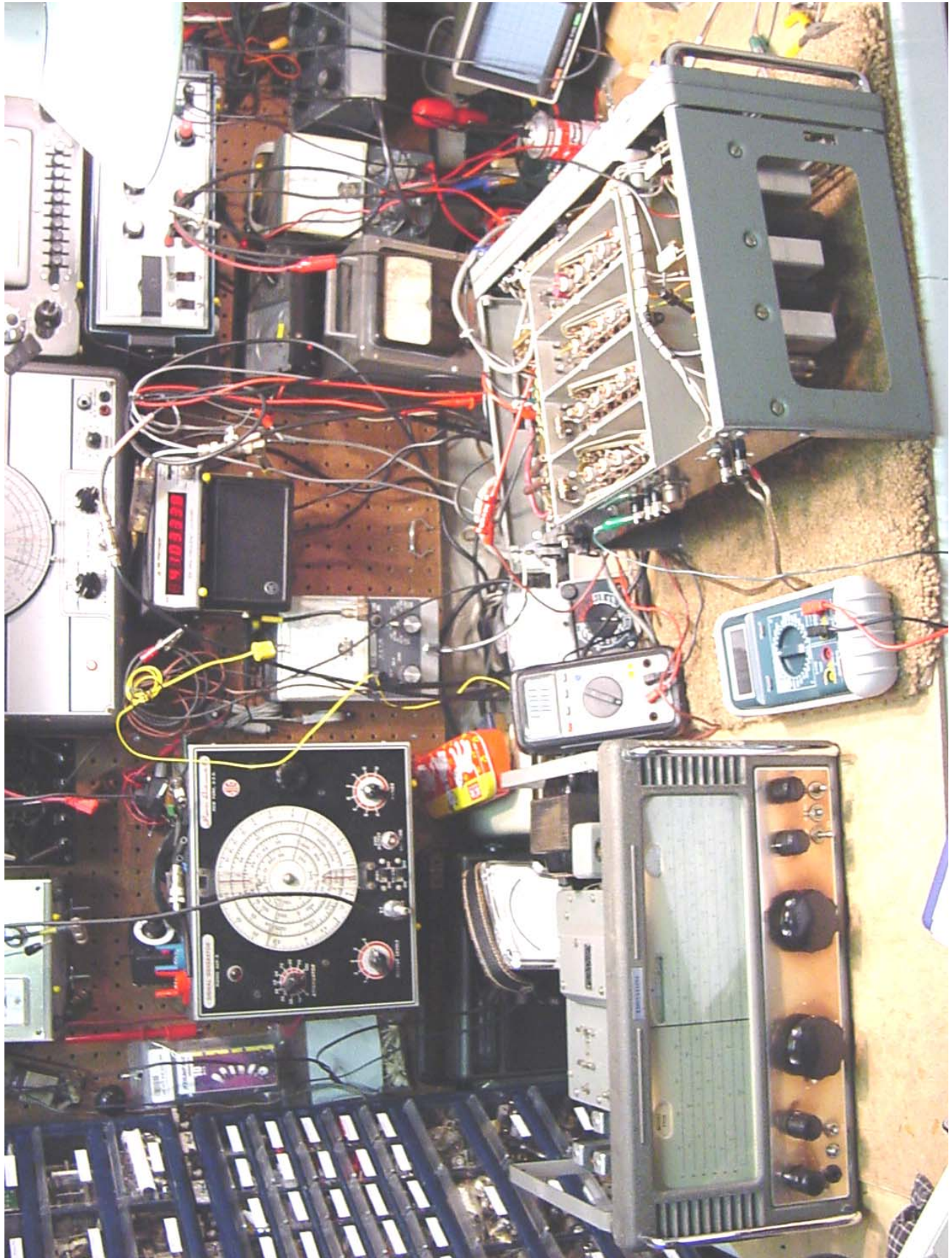

The temporary 'jump start' arrangement of powering the S.940 using the S.770R power supply – it feels strange switching one receiver on and the other one actually powering-up...



A nice shiny new 5Z4G fitted and not an electron to rectify...

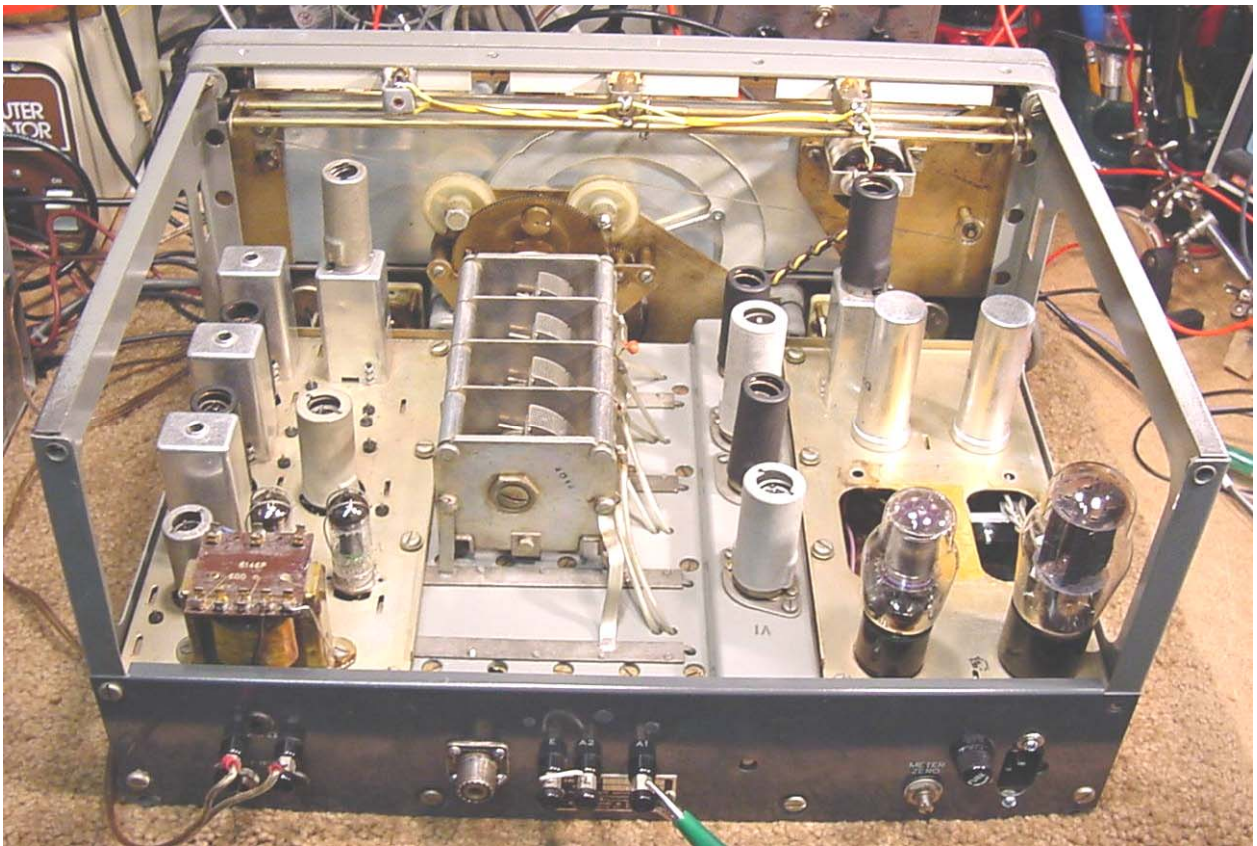

The S.940 isn't bad inside either – "...look mum, I'm working good without a transformer..." (there surely must be less painful ways to lose a few pounds?)



The S.940 on 'soak test' powered by the S.770R



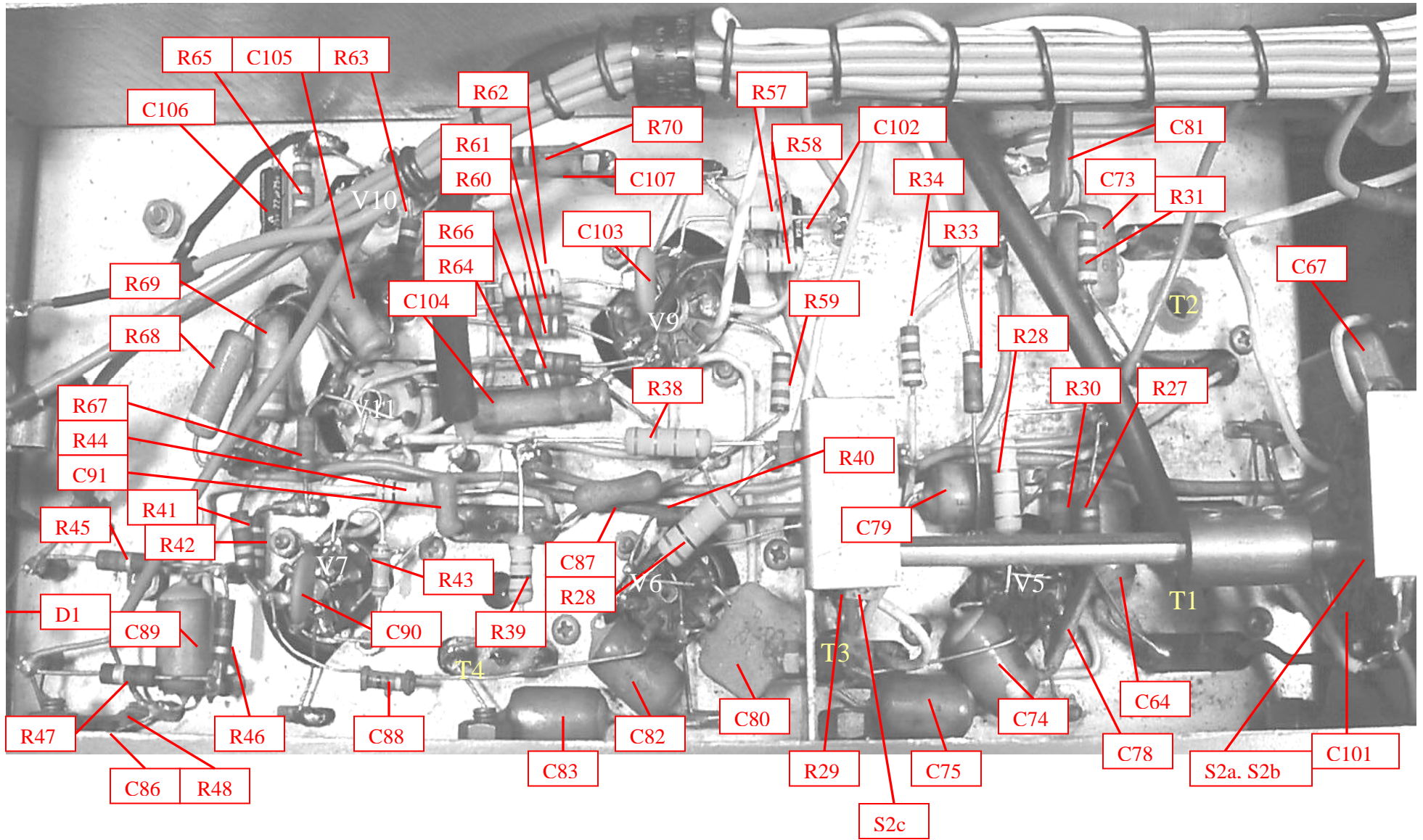

S.940 IF/AF sub-chassis with components identified

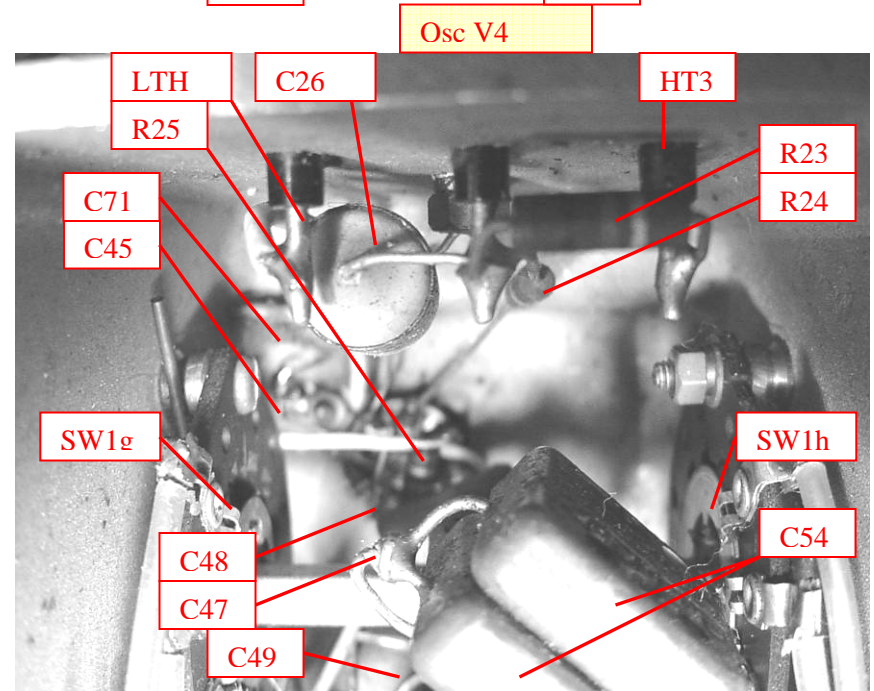
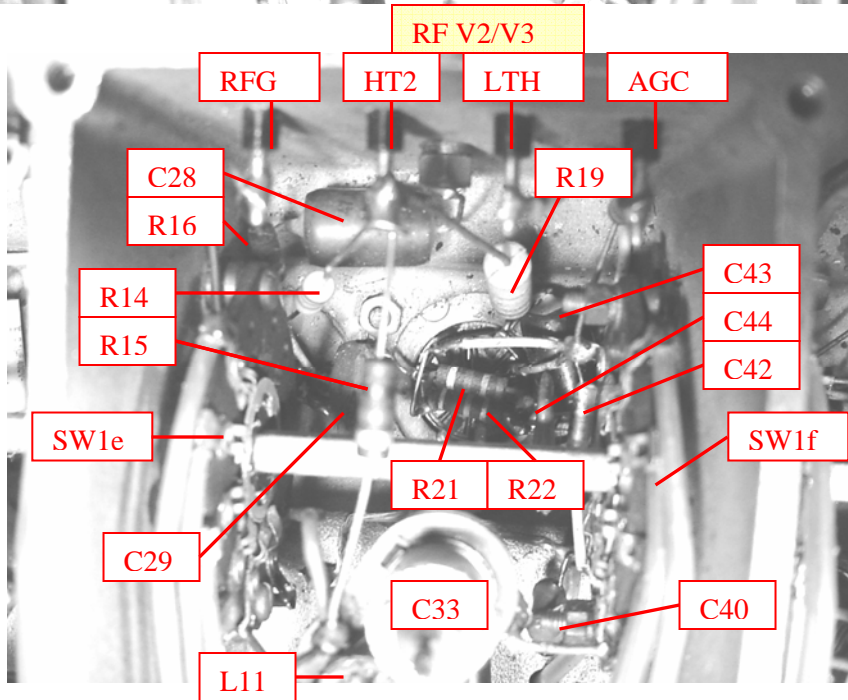
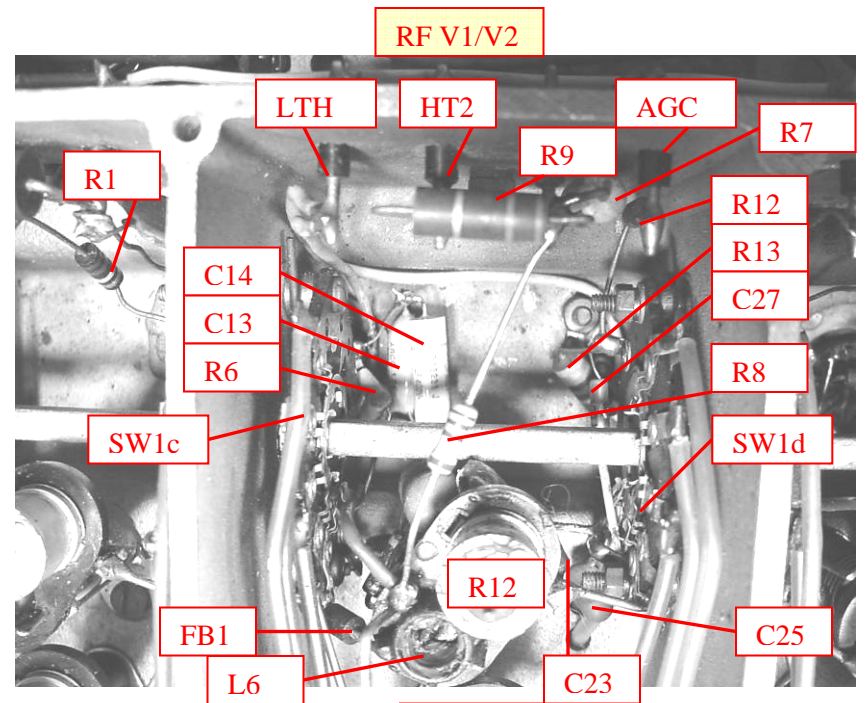
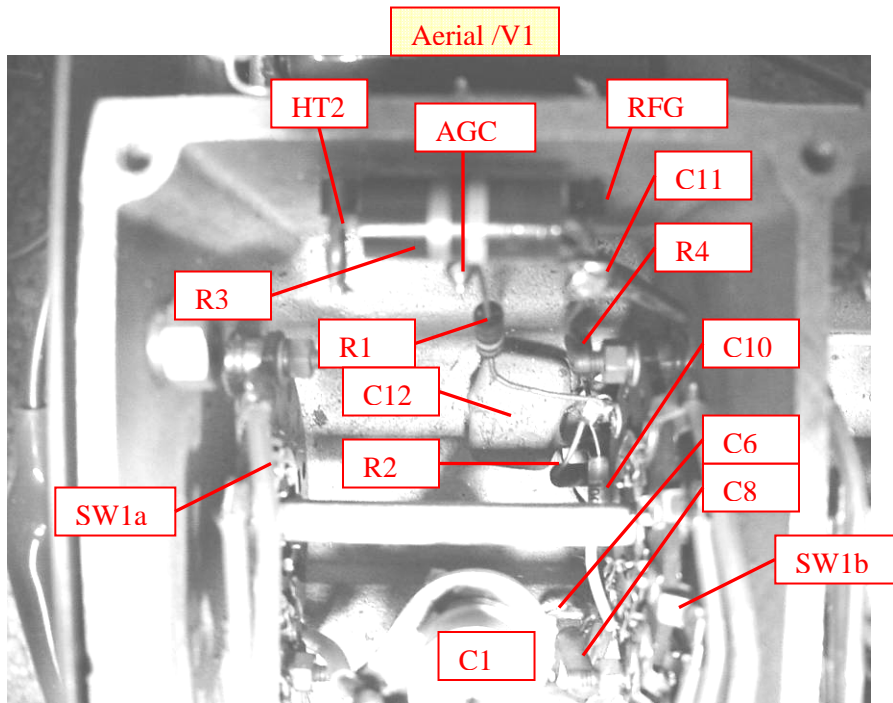

S.940 RF sub-chassis with components identified

EDDYSTONE

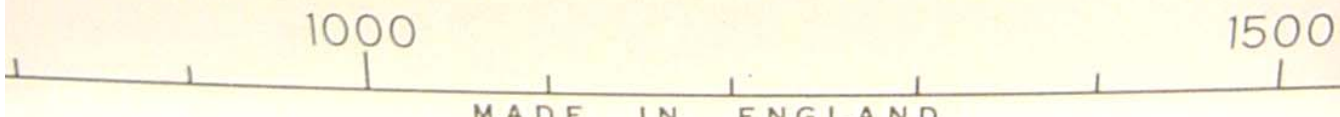
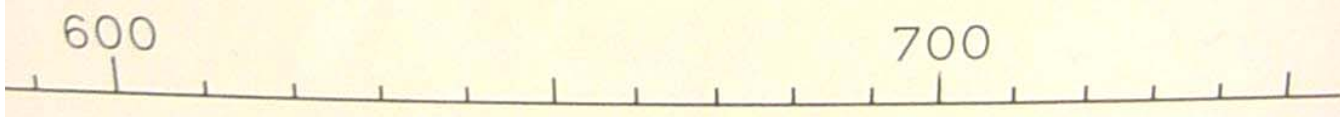
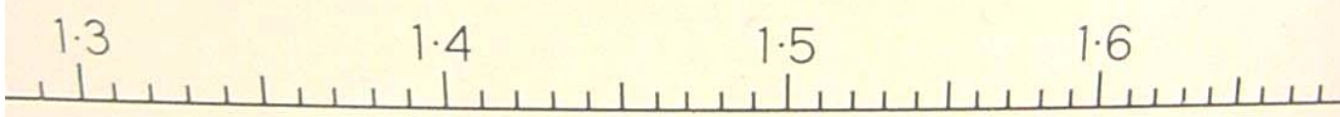
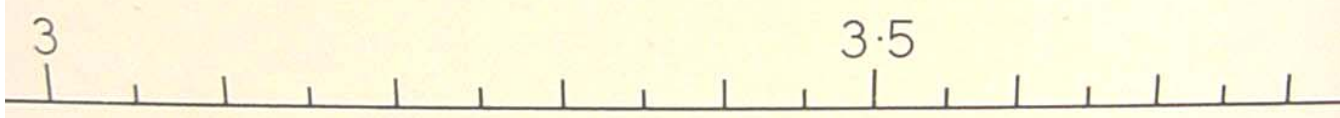
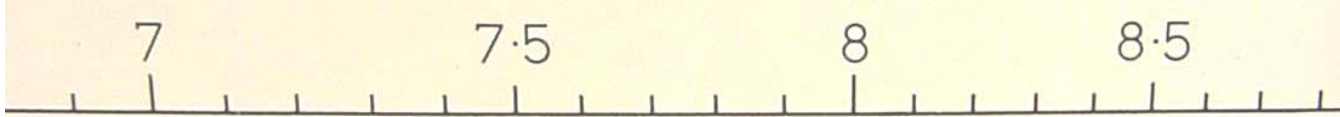
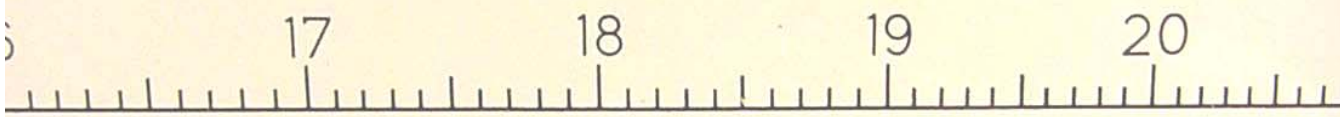

MADE IN ENGLAND