

ASSEMBLING
the

hallicrafters kit

model HT-40K

MARK I

Transmitter

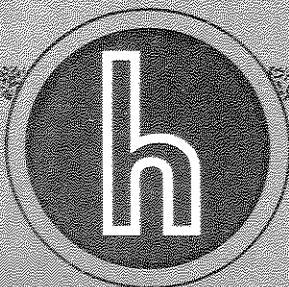

the hallicrafters co.

4401 WEST FIFTH AVENUE • CHICAGO 24, ILLINOIS

A
ste

part of
leads
with

WARRANTY

The Hallicrafters Company warrants each part or component supplied with this kit to be free of defective material and workmanship, and agrees to replace any part or component that, under normal installation, use, and service, discloses such defect. Upon return of the intact part or component to the factory, for examination, with all transportation charges prepaid, within ninety days from the date of sale to original purchaser, and provided that such examination discloses in our judgement that it is thus defective, it will be replaced.

This warranty does not extend to any parts or components supplied with this kit that have been subjected to misuse, neglect, accident, incorrect wiring, improper installation, or use in violation of instructions furnished by us, nor does this warranty extend to units that have been repaired or altered outside of our factory, or to accessories used therewith not of our own manufacture. No replacement will be made for parts damaged by the purchaser during the assembling or handling of this kit.

Hallicrafters liability under this warranty is limited to the replacement of the part or component part determined to be defective. The Hallicrafters Company assumes no liability for consequential damages including but not limited to personal injury, damage to property and loss of time. This warranty is in lieu of all other warranties expressed or implied, and no representative or person is authorized to assume for us any other liability in connection with the sale of our radio products.

IMPORTANT NOTE

THIS WARRANTY WILL BE COMPLETELY VOID AND THE HALLICRAFTERS COMPANY WILL NOT REPLACE, REPAIR, OR SERVICE EQUIPMENT IN WHICH ACID CORE SOLDER OR PASTE FLUXES HAVE BEEN USED.

The registration card furnished with each Hallicrafters kit must be completed and returned to The Hallicrafters Company immediately after purchase. The above warranty applies only to equipment that is registered with Hallicrafters.

INTRODUCTION

GENERAL

The Hallicrafters Model HT-40K MK I Transmitter Kit is so designed that it may be constructed by individuals with minimum electronic training or experience. The component parts have been carefully selected to insure excellent performance and long life. To eliminate errors in assembly, it is suggested that each step of the assembly procedure be read and performed with care. Take your time -- work carefully--follow instructions. The result will be a quality transmitter whose operation will give you great satisfaction.

MANUALS

Two manuals are packed with the Model HT-40K MK I Transmitter Kit: The Assembly Manual, "Assembling The Halli-Kit" (this manual), contains material to instruct the builder in the assembly of this kit. The Operation Manual, "Operating and Service Instructions," contains material designed to instruct the owner in operating procedures, system installation, alignment, trouble shooting, and any service problem which may arise. The builder is advised to read both manuals thoroughly prior to unpacking or constructing the kit. This will familiarize him with the parts and construction procedures.

The Assembly Manual includes fold-in pictorials. These pictorials may be fastened to the wall over the work area or placed where they can easily be referred to during the assembling of the transmitter.

The manuals should be retained for future reference.

UNPACKING

After carefully reading the manuals, it is suggested that a clean, well-lighted work area be prepared before unpacking the kit. Remove the parts from the carton, check the quantity and description of each item against the parts check-off list on pages at the back of this manual and group them in assembly order. Place each group in a small container such as a cup-cake tin. Parts illustrations and chart information provided on pages 27 through 33 help to identify and determine the value of the parts in the kit. If any part is missing, broken, or of the wrong value, notify the dealer from whom the kit was purchased or The Hallicrafters Company for authorization to return the broken or incorrect parts or to obtain the parts which are missing.

In general, the transformers, terminal strips, and tube sockets will be installed first; followed by the wiring harness, jumper wires, and smaller electrical components; the assembly of the front panel, mounting of the tuning capacitors, and installation of the band selector switch and tubes. If the parts are layed out in this general order, construction will be greatly simplified.

TOOLS REQUIRED

The Model HT-40K MK I Transmitter Kit can be constructed with standard tools. The builder should have long-nose pliers, diagonal or side-cutting pliers, a screwdriver with a 3/16-inch blade, a screwdriver with a 1/8-inch blade, and a soldering iron (preferably one with a heating element of not more than 60 watts) available.

SOLDERING TECHNIQUES

Proper soldering techniques are very important in the assembly of the kit. To obtain the performance engineered into this kit, it is essential that good solder joints be made. A good solder joint ensures an electrical connection and seals the joint from air and moisture to prevent corrosion which could introduce high resistance into the circuit. If the kit builder is unfamiliar with wiring and soldering, the following steps (illustrations A through E) should be carefully studied.

IMPORTANT: Only good quality rosin core solder is to be used in the construction of this kit. A sufficient amount of rosin core solder is supplied with this kit. NEVER use acid core solder or a paste flux. The use of acid core solder or a paste flux will void the warranty on this equipment.

1. The soldering iron element or tip should be cleaned and tinned (covered with a thin coat of solder).
2. Before soldering, be sure the terminals and the leads are free from dirt and corrosion. Leads and terminals which are dirty or discolored (corroded) can be cleaned by scraping them with a knife.

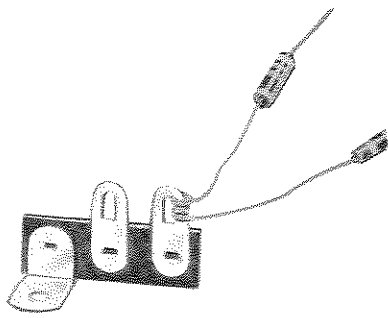

A. WIRED CONNECTION

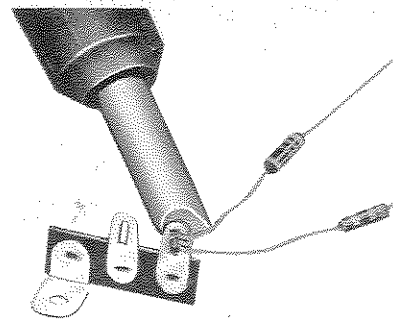

B. PROPER APPLICATION OF HEAT

092-010236

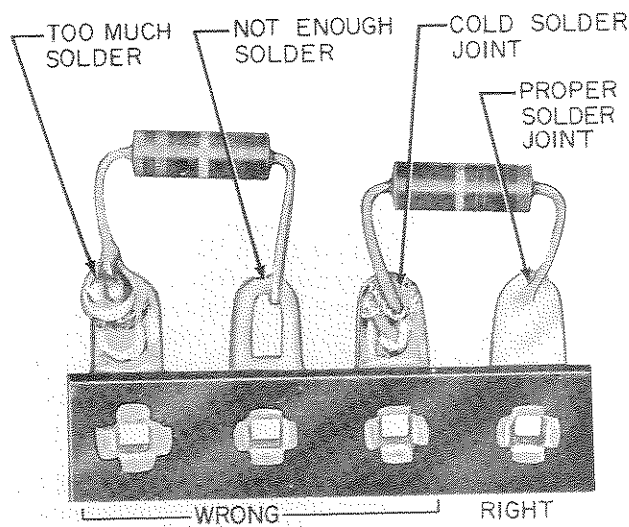

C. SOLDERED CONNECTIONS

092-010235

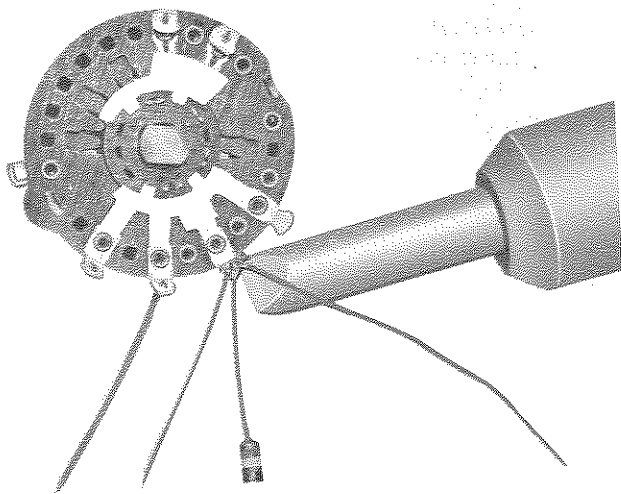

D. SOLDERING WAFER TERMINAL

092-010238

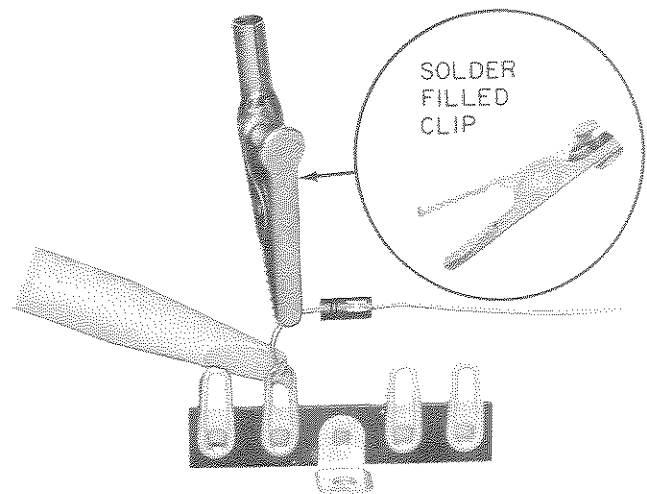

E. HEAT SINKING A DIODE

092-010551

Soldering Techniques

3. Tin all wires and leads before making connections; this is accomplished by applying a small coating of solder to the lead.
4. Make a mechanical connection before soldering. Leads should be kept as short as possible on small items. Proper lead lengths are given for the individual parts as they are assembled. Leads should be trimmed as specified.
5. Apply heat to the connection with the flat portion of the soldering iron tip. DO NOT apply more heat than is necessary to allow the solder to flow evenly over the connection. Make certain that heat is applied to the whole connection (leads and solder terminal). If heat is not applied evenly, a cold solder joint will result and introduce resistance into the circuit.
6. Apply solder simultaneously to the connection and the tip of the soldering iron until the solder melts and flows around and into the connection. Apply only enough solder to cover the leads of the connection; do not apply an excessive amount of solder. Never move the component that is being soldered until after the solder has cooled or solidified.
7. When soldering to a lug on a switch wafer, the switch should be so positioned that the lug to be soldered is on the lower side of the wafer. It may be necessary to turn the chassis if the switch has already been installed. Apply heat and solder to the lower side of the lug; the solder will flow upward into the connection. This method of soldering will prevent the solder from running into the switch and shorting the contacts.
8. Components such as rectifiers (CR1, CR2, and CR3) should be protected from heat when soldering. Alligator clips filled with solder or long-nosed pliers placed on the lead between the component and the connection will conduct the heat away from the soldered component.

ASSEMBLY INSTRUCTIONS

GENERAL

Each step of the following assembly procedures should be read and understood in its entirety before it is performed. When each step is completed, place a check mark in the parentheses preceding the step.

Each assembly step involving the connection of wires or leads will be followed by a symbol, in parentheses, indicating if soldering is required or not. The symbols for soldering requirements are as follows: Do not solder - (DS), Solder 1 lead - (S-1), Solder 2 leads - (S-2), etc.

WARNING

DANGEROUS VOLTAGES EXIST ON BOTH THE TOP AND BOTTOM OF THE CHASSIS. CLOSE EXAMINATION OF THE SCHEMATIC DIAGRAM AND CIRCUIT ARRANGEMENT WILL POINT OUT THESE DANGER SPOTS. HOWEVER, PRECAUTIONS SHOULD BE TAKEN TO KEEP OTHER PEOPLE AWAY FROM THE EQUIPMENT WHILE IT IS TURNED ON, OR WHEN IT IS BEING WORKED ON.

STEP-BY-STEP ASSEMBLY PROCEDURE

MOUNTING TRANSFORMER, CHOKE, SOCKETS AND TERMINAL STRIPS

(Refer to Pictorials 1, 2 and Figures 1, 2, 3, 4, 5, and 6 when assembling this section)

1. (✓) Mount the power transformer T1 and two four-lug terminal strips, TS1 and TS2, to the chassis with four No. 6 x 3/8 inch sems screws, four No. 6 flat washers, two No. 6 kep nuts, two No. 6 internal tooth lockwashers, and two No. 6 hex nuts as shown in pictorial 1.
2. (✓) Mount the filter choke L12 and three terminal strips, TS12, TS13, and TS14, to the chassis with four No. 6 x 3/8 inch sems screws, four No. 6 flat washers, four No. 6 internal tooth lockwashers, and four No. 6 hex nuts as shown in pictorial 1.
3. (✓) Mount the 9-pin miniature tube sockets XV1, XV3, and XV4 and socket-shield bases in chassis holes 25, 26, and 27 with No. 4 x 5/16 inch sems screws, No. 4 internal tooth lockwashers, and No. 4 hex nuts as shown in pictorial 2 and figures 1 and 2. Be sure that the open space in the socket's terminal arrangement is as shown in pictorial 2.
4. (✓) Mount a three-lug terminal strip, TS3, at chassis hole 5 with a No. 4 x 5/16 inch sems screw, a No. 4 lockwasher, and a No. 4 hex nut as shown in pictorial 2 and figure 3.
5. (✓) Mount the four-lug terminal strip TS4 at chassis hole 6 as in Step 4.
6. (✓) Mount the two-lug terminal strip TS7 at chassis hole 28 as in Step 4.
7. (✓) Mount the four-lug terminal strip TS8 at chassis hole 29 as in Step 4.
8. (✓) Mount the five-lug terminal strip TS10 at chassis hole 31 as in Step 4.
9. (✓) Mount the two-lug terminal strip TS11 at chassis hole 32 as in Step 4.
10. (✓) Mount the three-lug terminal strip TS16 at chassis hole 42 as in Step 4.
11. (✓) Mount the three-lug terminal strip TS17 at chassis hole 43 as in Step 4.
12. (✓) Mount a five-lug and a two-lug terminal strip, TS9 and TS19 respectively, at chassis hole 30 with a No. 4 x 5/16 inch sems screw, two No. 4 internal tooth lockwashers, and a No. 4 hex nut as shown in pictorials 2 and 5.
13. (✓) Mount the antenna connector J5 and a three-lug terminal strip, TS18, to the chassis at chassis holes W, 44, 45, 46, and 47 with four No. 4 x 5/16 inch sems screws, three No. 4 internal tooth lockwashers, a No. 4 solder lug, and four No. 4 hex nuts as shown in pictorial 2.
14. (✓) Mount the four-connector board TA1, marked 1, 2, 3, and 4, at chassis holes 48 and 49 so that the numerals (1, 2, 3, and 4) are located as shown in pictorial 2. Use two No. 4 x 5/16 inch sems screws, two No. 4 solder lugs, and two No. 4 hex nuts.
15. (✓) Mount the bandswitch S2 in chassis hole 7 and insert the locating key in the oblong hole adjacent to chassis hole 7. Secure switch S2 with a 3/8-inch black palnut. Finger tighten only (this nut must be removed when installing the front panel).
16. (✓) Secure the rear support bracket of S2 at chassis hole 8 with a No. 6 x 3/8 inch sems screw, a No. 6 solder lug, and a No. 6 hex nut as shown in pictorial 2.
17. (✓) Mount the two section plate tuning capacitor C17 at chassis holes 13, 14, and 15 with three No. 6 x 1 inch sems screws and three 3/4-inch long brass spacers as shown in pictorials 2 and 5, and in figure 4.

NOTE: Rotate the capacitor shaft fully counterclockwise to prevent damage to the capacitor plates.

18. (✓) Mount the drive tuning capacitor C15 to the front chassis flange at chassis holes 16, 17, and 18 with two No. 6 x 1/4 inch flat-head screws and a 1/2-inch internal tooth lockwasher as shown in pictorial 2 and figure 5.
19. (✓) Mount the plate loading capacitor C25 and a four-lug terminal strip, TS15, at chassis holes 39, 40, and 41 with three No. 6 x 1 inch sems screws and three 3/4-inch long brass spacers as shown in pictorials 2 and 5, and in figure 4.

NOTE: Rotate the capacitor shafts fully counterclockwise to prevent damage to the capacitor plates.

20. (✓) Mount the single-pole, double-throw (SPDT) slide switch S1 in chassis holes 19, 20, and 21 with two No. 4 x 1/4 inch flat-head screws as shown in pictorial 2.
21. (✓) Mount the double-pole, double-throw (DPDT) slide switch S4 in chassis holes 22, 23, and 24 with two No. 4 x 1/4 inch flat-head screws as shown in pictorial 2.
22. (✓) Mount the plate RF choke L13 to the chassis at chassis hole 56 with a No. 6 x 1/2 inch sems screw. Use a No. 6 x 3/8-inch fiber spacer between the RF choke and the chassis as shown in pictorials 1 and 5.
23. (✓) Mount the two stand-off insulators SI-1 and SI-2 at chassis holes 37 and 38 with two No. 6 x 3/8 inch sems screws and two No. 6 fiber washers as shown in pictorials 2 and 5.
24. (✓) Mount a No. 6 solder lug on stand-off insulators SI-1 and SI-2 with two No. 6 x 3/8 inch sems screws and two No. 6 fiber washers as shown in pictorial 5.
25. (✓) Mount the microphone gain control R16 in chassis hole 52 with a 3/8-inch cadmium plated palnut as shown in pictorial 2.
26. (✓) Mount the microphone connector J4 in chassis hole 53 with a 3/8-inch flat washer, a 3/8-inch solder lug, a 3/8-inch lockwasher, and a 3/8-inch cadmium plated hex nut as shown in pictorial 2 and figure 6.

MOUNTING TUBE SOCKET XV2 AND PRELIMINARY WIRING

(Refer to Pictorial 3 and Figures 8 and 9 when assembling and wiring this section)

NOTE: Strip 3/8 inch of insulation off each end of all insulated wires used in the assembly of this kit before making a connection to any terminal. All wire and lead lengths may be further trimmed as installed if so desired.

27. (✓) Mount the octal socket XV2 and a one-lug terminal strip, TS5, to the tube mounting bracket with two No. 4 x 5/16 inch sems screws, two No. 4 internal tooth lockwashers, and two No. 4 hex nuts as shown in pictorial 3 and figure 8. Make sure that the keyway of the octal socket is as shown in pictorial 3.
28. (✓) Mount the tube socket mounting bracket and a two-lug terminal strip, TS6, to the chassis at chassis holes 9, 10, 11, and 12 with four No. 4 x 5/16 inch sems screws, four No. 4 internal tooth lockwashers, and four No. 4 hex nuts as shown in pictorial 3 and figure 8. Make sure that the mounting bracket is positioned with the tube socket keyway as shown.
29. (✓) Connect the short black lead from chassis hole Z to terminal 1 of terminal strip TS14 (DS).
30. (✓) Connect the long black lead from chassis hole Z to terminal 1 of terminal strip TS2 (DS).
31. (✓) Connect the short black lead from chassis hole X to terminal 3 of terminal strip TS16 (DS).
32. (✓) Connect the long red lead from chassis hole Y to terminal 2 of terminal strip TS15 (DS).
33. (✓) Connect the short red lead from chassis hole Y to terminal 4 of terminal strip TS1 (DS).
34. (✓) Connect one of the green wires from chassis hole Y to terminal 2 of terminal strip TS1 (S-1) and the other green wire from chassis hole Y to terminal 3 of terminal strip TS1 (DS).

35. (✓) Connect a 2-inch length of red wire between terminal 1 of terminal strip TS1 (DS) and terminal 4 of terminal strip TS1 (DS).
36. (✓) Connect a 2-inch length of red wire between terminal 1 of terminal strip TS3 (DS) and terminal 3 of terminal strip TS3 (DS).
37. (✓) Connect a 1-5/8-inch length of violet wire between terminal 1 of terminal strip TS7 (DS) and terminal 2 of terminal strip TS7 (DS).
38. (✓) Connect a 1-1/4-inch length of gray wire between terminal 2 of terminal strip TS14 (DS) and terminal 3 of terminal strip TS14 (DS).
39. (✓) Connect a short piece of No. 22 bare tinned wire between terminal 1 of terminal strip TS12 (DS) and terminal 2 of terminal strip TS12 (DS).
40. (✓) Run a short piece of No. 22 bare tinned wire from the center post of tube socket XV1 (S-1), through socket terminal 4 (DS), to socket GND Lug 2 (S-1).
41. (⊗) Run a short piece of No. 22 bare tinned wire from the center post of tube socket XV3 (S-1), through socket terminals 3 (S-1), 4 (S-1), and 5 (S-1), to socket GND Lug 3 (DS).
42. (⊗) Connect a short piece of No. 22 bare tinned wire to socket GND Lug 4 of tube socket XV4 (DS). Run this wire through socket terminal 8 (S-1), through the socket center post (S-1), through socket terminal 5 (DS), to socket GND Lug 3 (DS).

NOTE: Each cable harness breakout is designated with cable harness nomenclature (WH-1) and a letter suffix (a), (b), etc. (i.e., WH-1a).

43. (⊗) Locate and position the cable harness WH-1 on the chassis as shown in pictorial 3.
44. (✓) Connect the violet wire at WH-1a to terminal 5 on wafer "B" of bandswitch S2 (DS).
45. (✓) Connect the gray wire at WH-1a to terminal 1 of terminal strip TS15 (DS).
46. (✓) Connect the red wire at WH-1b to terminal 2 of terminal strip TS9 (DS).
47. (✓) Connect the violet wire at WH-1c to terminal 5 of the DPDT slide switch S4 (DS).
48. (✓) Connect the yellow wire at WH-1c to terminal 1 of terminal strip TS10 (DS).
49. (✓) Connect the orange wire at WH-1c to terminal 5 of terminal strip TS10 (DS).
50. (✓) Connect a 3-inch length of yellow wire between terminal 1 of terminal strip TS10 (DS) and terminal 9 of tube socket XV4 (DS).
51. (✓) Connect a 2-1/2-inch length of blue wire between terminal 1 of tube socket XV4 (DS) and terminal 1 of terminal strip TS11 (DS).
52. (✓) Connect the blue wire at WH-1c to terminal 1 of tube socket XV4 (S-2).
53. () Connect the green wire at WH-1c to terminal 2 of tube socket XV4 (S-1).
54. (✓) Connect the white wire at WH-1c to terminal 6 of tube socket XV4 (DS).
55. () Connect the gray wire at WH-1c to terminal 1 of terminal strip TS19 by passing the wire up through chassis hole 59 (DS). Refer to pictorials 3 and 5.
56. (✓) Connect a 2-inch length of No. 22 bare tinned wire between terminal 1 of the SPDT slide switch S1 (S-1) and terminal 1 of terminal strip TS9 (DS).
57. (✓) Connect a short piece of No. 22 bare tinned wire between terminal 3 of the microphone gain control R16 (DS) and the 3/8-inch ground lug of the microphone connector J4 (S-1).

58. (✓) Connect a short piece of No. 22 bare tinned wire between terminal 4 of TA1 (DS) and the No. 4 solder lug at chassis hole 48 (S-1).
59. (✓) Connect a 3-inch length of white wire between terminal 2 of the driver tuning capacitor C15 (S-1) and terminal 8 on wafer "A" of bandswitch S2 (S-1).

INSTALLATION AND WIRING OF THE FUNCTION SWITCH S3, CABLE HARNESS
WH-2, AND PRELIMINARY COMPONENT WIRING.

(Refer to Pictorials 4 and 5 and Figure 10 and 11 when wiring this section)

Locate cable harness WH-2 and function switch S3. The function switch is wired to WH-2 prior to installation. Place the function switch so that the locating key is as shown in figure 10 before wiring.

60. (✓) Connect a 2-1/2-inch length of black wire to terminal 9 on the front of the wafer of switch S3 (S-1).
61. (✓) Connect one of the yellow wires from WH-2a to terminal 7 on the rear of the wafer of switch S3 (S-1).
62. (✓) Connect the remaining yellow wire from WH-2a to terminal 8 of switch S3 (S-1).
63. (✓) Connect the gray wire from WH-2a to terminal 6 of switch S3 (S-1).
64. (✓) Connect the orange wire from WH-2a to terminal 5 of switch S3 (DS).
65. (✓) Connect the blue wire from WH-2a to terminal 2a of switch S3 (DS).
66. (✓) Connect the white/red wire from WH-2a to terminal 2 on the AC snap-switch mounted on the rear of switch S3 (S-1).
67. (✓) Position the cable harness WH-2 in the chassis as shown in pictorial 4. DO NOT MOUNT FUNCTION SWITCH S3 AT THIS TIME.
68. (✓) Connect the orange wire from WH-1a to terminal 5 of switch S3 (S-2).
69. (✓) Connect the yellow wire from WH-1a to terminal 3 of switch S3 (DS).
70. (✓) Connect the blue wire from WH-1a to terminal 2a of switch S3 (S-2).
71. (✓) Connect the red wire from WH-1a to terminal 1 of switch S3 (S-1).
72. (✓) Connect the green wire from WH-1a to terminal 10 of switch S3 (S-1).
73. (✓) Connect the white wire from WH-1a to terminal 11 of switch S3 (S-1).
74. (✓) Mount the function switch S3 in chassis hole 50 and insert the locating key in hole 60. Secure switch S3 with a 3/8-inch black palnut and finger tighten only (this nut must be removed when installing the front panel).
75. (✓) Connect the black wire from terminal 9 of switch S3 to terminal 4 of terminal strip TS4 (S-1).
76. (✓) Connect the black wire from WH-2a to terminal 3 of terminal strip TS4 (DS).
77. (✓) Connect the red wire from WH-2a to terminal 1 of terminal strip TS15 (DS).
78. (✓) Connect the red wire from WH-2b to terminal 3 of terminal strip TS3 (DS).
79. (✓) Connect the brown wire from WH-2c to terminal 3 of terminal strip TS1 (S-2).
80. (✓) Connect the white/red wire from WH-2d to terminal 1 of terminal strip TS16 (DS).
81. (✓) Connect the black wire from WH-2d to terminal 3 of terminal strip TS16 (DS).

82. (✓) Connect the two gray wires from WH-2e to terminal 3 of terminal strip TS2 (DS).
83. (✓) Connect the orange wire from WH-2f to terminal 1 of terminal strip TS18 (DS).
84. (✓) Connect the white/black wire from WH-2g to terminal 3 of connector board TA1 (DS).
85. (✓) Connect one of the yellow wires from WH-2g to terminal 2 of connector board TA1 (DS).
86. (✓) Connect the remaining yellow wire from WH-2g to terminal 1 of connector board TA1 (DS).
87. (✓) Connect the red wire from WH-2h to terminal 1 of terminal strip TS14 (DS).
88. (✓) Connect the gray wire from WH-2h to terminal 2 of terminal strip TS14 (DS).
89. (✓) Connect the three shield (braided) conductors of the green, gray, and black shielded cables at WH-2i to terminal 3 of the microphone gain control R16 (S-4).
90. (✓) Connect the center (insulated) conductor of the green shielded wire at WH-2i to terminal 1 of terminal strip TS13 (DS).
91. (✓) Connect the center conductor of the gray shielded wire at WH-2i to terminal 2 of control R16 (S-1).
92. (✓) Connect the center conductor of the black shielded wire at WH-2i to terminal 1 of control R16 (S-1).
93. (✓) Connect the violet wire from WH-2j to terminal 1 of terminal strip TS12 (DS).
94. (✓) Connect the shield conductor of the black shielded wire at WH-2k to terminal 3 of terminal strip TS12 (S-1).
95. (✓) Connect the center conductor of the black shielded wire at WH-2k to terminal 4 of terminal strip TS12 (DS).
96. (✓) Connect the shield conductor of the green shielded wire at WH-2l to GND Lug 1 of tube socket XV3 (DS).
97. (✓) Connect the center conductor of the green shielded wire at WH-2l to terminal 2 of tube socket XV3 (DS).
98. (✓) Connect the brown wire at WH-2m to terminal 9 of tube socket XV3 (DS).
99. (✓) Connect the shield conductor of the gray shielded wire at WH-2m to GND Lug 4 of tube socket XV3 (S-1).
100. (✓) Connect the center conductor of the gray shielded wire at WH-2m to terminal 7 of the tube socket XV3 (S-1).
101. (✓) Connect the brown wire from WH-2n to terminal 4 of tube socket XV4 (S-1).
102. (✓) Connect the orange wire from WH-2n to terminal 1 of slide switch S4 (DS).
103. (✓) Connect the shield conductor of the orange shielded wire at WH-2n to terminal 3 of terminal strip TS10 (DS).
104. (✓) Connect the center conductor of the orange shielded wire at WH-2n to terminal 2 of terminal strip TS10 (DS).
105. (✓) Connect the shield conductor of the orange shielded wire at WH-2p to GND Lug 1 of tube socket XV2 (DS).
106. (✓) Connect the center conductor of the orange shielded wire at WH-2p to terminal 1 of terminal strip TS5 (DS).

107. (✓) Connect the violet wire from WH-2p to terminal 1 of terminal strip TS7 (DS).
108. (✓) Connect the orange wire from WH-2q to terminal 8 of tube socket XV2 (DS).
109. (✓) Connect the two brown wires from WH-2q to terminal 7 of tube socket XV2 (DS).
110. (✓) Pass the blue wire from WH-2q up through chassis hole 51 and connect it to terminal 1 of the RF choke L13 (DS). Refer to pictorial 5.
111. (✓) Connect the red wire from WH-2r to terminal 1 of terminal strip TS8 (DS).
112. (✓) Connect the brown wire from WH-2r to terminal 5 of tube socket XV1 (DS).
113. (✓) Connect the two brown wires from WH-2s to terminal 9 of tube socket XV3 (S-3).
114. (✓) Connect a 4-inch length of black wire between terminal 1 of the AC snap-switch mounted on the rear of the function switch S3 (DS) and terminal 1 of terminal strip TS4 (DS).
115. (✓) Connect a 4-inch length of white wire between terminal 4 of terminal strip TS8 (DS) and terminal 2 of terminal strip TS6 (S-1) by passing the wire up through chassis hole 51. Refer to pictorials 4 and 5.
116. (✓) Connect a 5-inch length of white wire between terminal 1 of the driver tuning capacitor C15 (S-1) and terminal 4 of terminal strip TS8 (DS).
117. (✓) Connect a 6-inch length of violet wire between terminal 2 of terminal strip TS10 (DS) and terminal 3 of terminal strip TS9 (DS).
118. (✓) Cut both leads of a 2500-ohm, 7-watt resistor, R7, to 1/2-inch lengths. Connect one lead to terminal 1 of terminal strip TS15 (DS) and the other lead to terminal 3 of terminal strip TS3 (S-3).
119. (✓) Cut both leads of a 20-ohm, 7-watt resistor, R26, to 1/2-inch lengths. Connect one lead to terminal 2 of terminal strip TS15 (S-2) and the other lead to terminal 2 of terminal strip TS3 (DS).
120. (✓) Cut both leads of a 22K-ohm, 2-watt resistor, R3, to 7/8-inch lengths. Connect one lead to terminal 3 of terminal strip TS15 (DS) and the other lead to terminal 1 of terminal strip TS3 (S-2).
121. (✓) Cut both leads of a 40 mfd, 350V, electrolytic capacitor, C44, to 3/4-inch lengths. Connect the positive (+) lead to terminal 1 of terminal strip TS2 (DS) and connect the other lead to terminal 1 of terminal strip TS1 (S-2).
122. (✓) Cut both leads of a 40 mfd, 350V, electrolytic capacitor, C45, to 3/4-inch lengths. Connect the positive (+) lead to terminal 4 of terminal strip TS1 (S-3) and connect the other lead to terminal 3 of terminal strip TS2 (DS).
123. (✓) Connect the cathode end (marked F) of diode CR1 to terminal 1 of terminal strip TS2 (S-3). Connect the anode end (marked 6) to terminal 2 of terminal strip TS3 (DS). CAUTION: WHEN INSTALLING THIS DIODE USE HEAT SINK. REFER TO STEP 8 OF SOLDERING TECHNIQUES. (DO NOT OVERHEAT.)
124. (✓) Connect the cathode end (marked F) of diode CR2 to terminal 2 of terminal strip TS3 (S-3). Connect the anode end (marked 6) to terminal 3 of terminal strip TS2 (DS). CAUTION: WHEN INSTALLING THIS DIODE USE HEAT SINK. REFER TO STEP 8 OF SOLDERING TECHNIQUES. (DO NOT OVERHEAT.)
125. (✓) Cut both leads of a 1000-ohm, 1/2-watt resistor, R24, to 1/2-inch lengths. Connect one lead to terminal 3 of terminal strip TS2 (S-5) and connect the other lead to terminal 4 of terminal strip TS2 (DS). CAUTION: WHEN INSTALLING THIS DIODE USE HEAT SINK. REFER TO STEP 8 OF SOLDERING TECHNIQUES. (DO NOT OVERHEAT.)

126. (✓) Cut both leads of a .005 mfd, 500V, ceramic disc capacitor, C39, to 5/8-inch lengths. Connect one lead to terminal 2 of terminal strip TS2 (S-1) and connect the other lead to terminal 4 of terminal strip TS2 (S-2).
127. (✓) Cut both leads of a .001 mfd, 1000V, ceramic disc capacitor, C43, to 1/2-inch lengths. Connect one lead to terminal 1 of terminal strip TS16 (DS) and connect the other lead to terminal 2 of terminal strip TS16 (DS).
128. (✓) Cut both leads of a .001 mfd, 1000V, ceramic disc capacitor, C42, to 1/2-inch lengths. Connect one lead to terminal 2 of terminal strip TS16 (S-2) and connect the other lead to terminal 3 of terminal strip TS16 (DS).
129. (✓) Cut both leads of a .001 mfd, 1000V, ceramic disc capacitor, C41, to 1/2-inch lengths. Connect one lead to terminal 1 of terminal strip TS17 (DS) and connect the other lead to terminal 2 of terminal strip TS17 (DS).
130. (✓) Cut both leads of a .001 mfd, 1000V, ceramic disc capacitor, C40, to 1/2-inch lengths. Connect one lead to terminal 2 of terminal strip TS17 (S-2) and connect the other lead to terminal 3 of terminal strip TS17 (DS).
131. (✓) Cut both leads of a .05 mfd, 50V, ceramic disc capacitor, C38, to 1/2-inch lengths. Connect one lead to terminal 1 of terminal strip TS18 (DS) and connect the other lead to terminal 2 of terminal strip TS18 (DS).
132. (✓) Cut both leads of a 2.2K-ohm, 1/2-watt resistor, R22, to 1/2-inch lengths. Connect one lead to terminal 2 of terminal strip TS18 (S-2) and connect the other lead to terminal 3 of terminal strip TS18 (DS).
133. (✓) Cut both leads of the type 1N295 diode CR3 (small glass diode) to 1-inch lengths. Connect the red striped end to terminal 3 of terminal strip TS18 (DS) and connect the other lead to terminal 1 of terminal strip TS18 (S-3). CAUTION: WHEN INSTALLING THIS DIODE, USE HEAT SINK. REFER TO STEP 8 OF SOLDERING TECHNIQUES. (DO NOT OVERHEAT.)
134. (✓) Cut both leads of a .001 mfd, 1000V, ceramic disc capacitor, C6, to 1/2-inch lengths. Connect one lead to terminal 4 of connector board TA1 (S-2) and connect the other lead to terminal 3 of connector board TA1 (S-2).
135. (✓) Cut both leads of a .001 mfd, 1000V, ceramic disc capacitor, C5, to 1-inch lengths. Connect one lead to GND Lug at chassis hole 49 (DS) and connect the other lead to terminal 2 of connector board TA1 (S-2).
136. (✓) Cut both leads of a .001 mfd, 1000V, ceramic disc capacitor, C4, to 1/2-inch lengths. Connect one lead to the GND Lug at chassis hole 49 (S-2) and connect the other lead to terminal 1 of connector board TA1 (S-2).
137. (✓) Cut both leads of a one-megohm, 1/2-watt resistor, R13, to 5/8-inch lengths. Connect one lead to terminal 2 of terminal strip TS13 (DS) and connect the other lead to terminal 4 of terminal strip TS13 (S-1).
138. (✓) Cut both leads of a 4.7K-ohm, 1/2-watt resistor, R12, to 1/2-inch lengths. Connect one lead to terminal 2 of terminal strip TS13 (DS) and connect the other lead to terminal 3 of terminal strip TS13 (DS).
139. (✓) Connect one end of a 2-inch length of No. 22 bare tinned wire to terminal 2 of terminal strip TS13 (S-3). Cut a 1-inch length of sleeving and slip it over the end of the bare wire. Push the free end of the wire through the center terminal of the microphone connector as shown in figure 11 (S-1).
140. () Cut both leads of a 56K-ohm, 2-watt resistor, R28, to 1-3/8-inch lengths. Connect one lead to terminal 2 of terminal strip TS14 (S-3) and connect the other lead to terminal 2 of terminal strip TS12 (S-2).

141. (✓) Cut both leads of a 56K-ohm, 2-watt resistor, R27, to 1-3/8-inch lengths. Connect one lead to terminal 1 of terminal strip TS14 (DS) and connect the other lead to terminal 1 of terminal strip TS12 (S-3).
142. (✓) Cut both leads of a 40 mfd, 350V, electrolytic capacitor, C47, to 5/8-inch lengths. Connect the positive (+) lead to terminal 2 of terminal TS7 (S-2) and connect the other lead to terminal 3 of terminal strip TS14 (S-2).
143. (✓) Cut both leads of a 40 mfd, 350V, electrolytic capacitor, C46, to 5/8-inch lengths. Connect the positive (+) lead to terminal 1 of terminal strip TS14 (S-4) and connect the other lead to terminal 1 of terminal strip TS7 (S-3).
144. (✓) Connect a short piece of No. 22 bare tinned wire between terminal 2 of tube socket XV2 (S-1) and GND Lug 1 of tube socket XV2 (S-2).
145. (✓) Cut both leads of a .001 mfd, 1000V, ceramic disc capacitor, C24, to 1/2-inch lengths. Connect one lead to terminal 3 of tube socket XV2 (DS) and connect the other lead to GND Lug 2 of tube socket XV2 (S-1).
146. (✓) Cut both leads of a .001 mfd, 1000V, ceramic disc capacitor, C23, to 1/2-inch lengths. Connect one lead to terminal 6 of tube socket XV2 (S-1) and connect the other lead to GND Lug 3 of tube socket XV2 (DS).
147. (✓) Cut both leads of a 9 mmf, 300V, duramica capacitor, C19, to 1/2-inch lengths. Connect one lead to terminal 5 of tube socket XV2 (DS) and connect the other lead to GND Lug 3 of tube socket XV2 (DS).
148. (✓) Cut both leads of a 22K-ohm, 2-watt resistor, R11, to 3/4-inch lengths. Connect one lead to GND Lug 3 of tube socket XV2 (S-3) and connect the other lead to terminal 4 of tube socket XV2 (S-1).
149. (✓) Cut both leads of a 56K-ohm, 1/2-watt resistor, R25, to 1/2-inch lengths. Connect one lead to terminal 2 of terminal strip TS4 (DS) and connect the other lead to terminal 3 of terminal strip TS4 (S-2).
150. (✓) Cut both leads of a 39K-ohm, 1-watt resistor, R9, to 1/2-inch lengths. Connect one lead to terminal 5 on wafer "B" of bandswitch S2 (S-2) and connect the other lead to terminal 3 on wafer "B" of switch S2 (DS).
151. (✓) Cut one lead of the 80-meter grid coil L3 to 1-inch length and the other lead to a 1-1/2-inch length. Connect the 1-inch lead to terminal 10 on wafer "A" of switch S2 (S-1). Pass the other lead through terminal 10 on wafer "B" of switch S2 (S-1) and connect it to terminal 11 on wafer "B" of switch S2 (DS).
152. (✓) Cut one lead of the 40-meter grid coil L4 to a 3/4-inch length and the other lead to a 1-1/4 inch length. Connect the 3/4-inch lead to terminal 11 on wafer "A" of switch S2 (S-1). Pass the other lead through terminal 11 on wafer "B" of switch S2 (S-2) and connect it to terminal 12 on wafer "B" of switch S2 (DS).
153. (✓) Cut one lead of the 20-meter grid coil L5 to a 3/4-inch length and the other lead to a 1-inch length. Connect the 3/4-inch lead to terminal 12 on wafer "A" of switch S2 (S-1). Pass the other lead through terminal 12 on wafer "B" of switch S2 (S-2) and connect it to terminal 1 on wafer "B" of switch S2 (DS).
154. (✓) Cut both leads of a 2.5 mh RF choke, L1, to 1-inch lengths. Connect one lead to terminal 3 of tube socket XV1 (DS) and connect the other lead to terminal 2 of terminal strip TS9 (DS).
155. (✓) Cut both leads of a 50 mmf, 600V, ceramic disc capacitor, C2, to 1/2-inch lengths. Connect one lead to GND Lug 1 of tube socket XV1 (DS) and connect the other lead to terminal 2 of tube socket XV1 (DS).
156. (✓) Cut both leads of a 100K-ohm, 1/2-watt resistor, R1, to 1/2-inch lengths. Connect one lead to GND Lug 1 of tube socket XV1 (S-2) and connect the other lead to terminal 2 of tube socket XV1 (DS).

157. (✓) Cut both leads of a 1 mh RF choke, L11, to 1-inch lengths. Connect one lead to terminal 1 of tube socket XV1 (DS) and connect the other lead to terminal 1 of terminal strip TS9 (S-2).
158. (✓) Cut both leads of a .01 mfd, 500V, ceramic disc capacitor, C7, to 1/2-inch lengths. Connect one lead to terminal 1 of tube socket XV1 (S-2) and connect the other lead to GND Lug 4 of tube socket XV1 (S-1).
159. (✓) Cut both leads of a .005 mfd, 500V, ceramic disc capacitor, C10, to 1/2-inch lengths. Connect one lead to terminal 4 of tube socket XV1 (S-2) and connect the other lead to terminal 5 of tube socket XV1 (S-2).
160. (✓) Cut both leads of a .1 mfd, 600V, molded paper capacitor, C32, to 1-1/4-inch lengths. Connect one lead to terminal 2 of terminal strip TS11 (DS) and connect the other lead to GND Lug 3 of tube socket XV1 (DS).
161. (✓) Cut both leads of a .005 mfd, 500V, ceramic disc capacitor, C12, to 1/2-inch lengths. Connect one lead to terminal 8 of tube socket XV1 (DS) and connect the other lead to GND Lug 3 of tube socket XV1 (DS).
162. (✓) Cut both leads of a 100K-ohm, 1/2-watt resistor, R4, to 1/2-inch lengths. Connect one lead to GND Lug 3 of tube socket XV1 (DS) and connect the other lead to terminal 7 of tube socket XV1 (DS).
163. (✓) Cut both leads of a .005 mfd, 500V, ceramic disc capacitor, C1, to 1/2-inch lengths. Connect one lead to terminal 5 of terminal strip TS9 (DS) and connect the other lead to terminal 3 of tube socket XV1 (DS).
164. (✓) Cut both leads of a 50 mmf, 600V, ceramic disc capacitor, C9, to 1/2-inch lengths. Connect one lead to terminal 3 of tube socket XV1 (S-3) and connect the other lead to terminal 7 of tube socket XV1 (S-2).
165. (✓) Connect a short piece of No. 22 bare tinned wire between terminal 9 of tube socket XV1 (S-1) and terminal 3 of terminal strip TS8 (DS).
166. (✓) Cut both leads of a 100 uh RF choke, L2, to 1/2-inch lengths. Connect one lead to terminal 1 of terminal strip TS8 (DS) and connect the other lead to terminal 3 of terminal strip TS8 (DS).
167. (✓) Cut both leads of a 50 mmf, 600V, ceramic disc capacitor, C14, to 1/2-inch lengths. Connect one lead to terminal 3 of terminal strip TS8 (S-3) and connect the other lead to terminal 4 of terminal strip TS8 (S-3).
168. (✓) Cut both leads of a 12K-ohm, 2-watt resistor, R6, to 3/4-inch lengths. Connect one lead to terminal 8 of tube socket XV1 (S-2) and connect the other lead to terminal 1 of terminal strip TS8 (DS).
169. (✓) Cut both leads of a .001 mfd, 1000V, ceramic disc capacitor, C13, to 1/2-inch lengths. Connect one lead to terminal 1 of terminal strip TS8 (S-4) and connect the other lead to terminal 2 of terminal strip TS8 (S-1).
170. (✓) Cut both leads of a 47K-ohm, 1/2-watt resistor, R2, to 1/2-inch lengths. Connect one lead to terminal 4 of terminal strip TS9 (DS) and connect the other lead to terminal 3 of terminal strip TS9 (DS).
171. (✓) Cut both leads of a .005 mfd, 500V, ceramic disc capacitor, C3, to 1/2-inch lengths. Connect one lead to terminal 3 of terminal strip TS9 (DS) and connect the other lead to terminal 4 of terminal strip TS9 (DS).
172. (✓) Cut both leads of a .005 mfd, 500V, ceramic disc capacitor, C8, to 5/8-inch lengths. Connect one lead to terminal 2 of terminal strip TS9 (S-3) and connect the other lead to terminal 4 of terminal strip TS9 (DS).

173. (✓) Cut both leads of a .005 mfd, 500V, ceramic disc capacitor, C49, to 3/4-inch lengths. Connect one lead to terminal 2 of slide switch S1 (DS) and connect the other lead to terminal 4 of terminal strip TS9 (S-4).
174. (✓) Cut both leads of a 100K-ohm, 1-watt resistor, R21, to 5/8-inch lengths. Connect one lead to GND Lug 4 of tube socket XV4 (S-2) and connect the other lead to terminal 9 of tube socket XV4 (DS).
175. (✓) Cut both leads of a 100 mfd, 1000V, ceramic disc capacitor, C35, to 1/2-inch lengths. Connect one lead to GND Lug 1 of tube socket XV4 (S-1) and connect the other lead to terminal 9 of tube socket XV4 (DS).
176. (✓) Cut both leads of a 10-megohm, 1/2-watt resistor, R18, to 1/2-inch lengths. Connect one lead to GND Lug 3 of tube socket XV4 (S-2) and connect the other lead to terminal 7 of tube socket XV4 (DS).
177. (✓) Cut both leads of a 100-ohm, 1/2-watt resistor, R30, to 1/2-inch lengths. Connect one lead to GND Lug 3 of tube socket XV3 (S-2) and connect the other lead to terminal 8 of tube socket XV3 (S-1).
178. (✓) Cut both leads of a .001 mfd, 1000V, ceramic disc capacitor, C33, to 1-inch lengths. Connect one lead to terminal 7 of tube socket XV4 (S-2) and connect the other lead to terminal 6 of tube socket XV3 (DS).
179. (✓) Cut both leads of a 2.2-megohm, 1/2-watt resistor, R14, to 1/2-inch lengths. Connect one lead to GND Lug 2 of tube socket XV3 (DS) and connect the other lead to terminal 2 of tube socket XV3 (DS).
180. (✓) Cut both leads of a one megohm, 1/2-watt resistor, R8, to 1/2-inch lengths. Connect one lead to terminal 6 of tube socket XV4 (S-2) and connect the other lead to terminal 1 of terminal strip TS11 (DS).
181. (✓) Cut both leads of a 470K-ohm, 1/2-watt resistor, R19, to 5/8-inch lengths. Connect one lead to terminal 1 of terminal strip TS11 (DS) and connect the other lead to terminal 2 of terminal strip TS11 (DS).
182. (✓) Cut both leads of a .01 mfd, 1400V, ceramic disc capacitor, C34, to 1/2-inch lengths. Connect one lead to terminal 1 of terminal strip TS11 (S-4) and connect the other lead to terminal 5 of tube socket XV4 (S-2).

INSTALLATION AND WIRING OF COMPONENTS ON TOP OF CHASSIS

(Refer to Pictorials 5 and 7 and Figure 12 when wiring this section)

183. (✓) Cut both leads of a .005 mfd, 1000V, ceramic disc capacitor, C37, to 1/2-inch lengths. Connect one lead to terminal 1 of the plate RF choke L13 (S-2) and connect the other lead to terminal 1 of terminal strip TS6 (S-1).
184. (✓) Connect a 3-3/4-inch length of No. 22 bare tinned wire between terminal 3 of the plate loading capacitor C25 (S-1) and the solder lug on stand-off insulator SI-2 (DS). When installing this wire, make sure that it connects with terminals 2 (S-1) and 1 (S-1) of the plate loading capacitor C25.
185. (✓) Connect the long end of the 6-meter tank coil L9 to terminals 2 (S-1) and 3 (S-1) on the plate tuning capacitor C17. Connect the other end to the solder lug on stand-off insulator SI-1 (DS).
186. (✓) Connect one lead of a .001 mfd, 3KV, ceramic disc capacitor, C18, to the long lead of the 6-meter tank coil L9 (S-1). Connect the other lead to terminal 2 of plate RF choke L13 (DS).
187. (✓) Connect the free lead of the parasitic choke coil PS-1 to terminal 2 on choke L13 (S-2).

188. (✓) Cut both ends of a 100 mmf, 2KV, ceramic disc capacitor, C26, to 1/2-inch lengths. Connect one lead to a 5-1/2-inch length of No. 22 bare tinned wire (splice the two leads together) (S-2) and connect the other lead to terminal 1 of the plate tuning capacitor C17 (S-1).
189. (✓) Cut a 4-3/4-inch length of sleeving and slip the sleeving over the long lead of capacitor C26. Pass this lead down through chassis hole 55. This lead will be connected later.
190. (✓) Insert the final tank coil L10 tap leads through chassis hole 55 and connect lead 7 to the solder lug of stand-off insulator SI-2 (S-2). Connect lead 1 to the solder lug of stand-off insulator SI-1 (S-2) as shown in pictorial 5 and figure 12.

ASSEMBLY, WIRING, AND MOUNTING OF THE FRONT PANEL

(Refer to Pictorial 6 and Figure 13 when assembling this section)

192. (✓) Locate the front panel and lay it down on a soft cloth or other surface that will not scratch or mar the panel.
193. (✓) Insert the meter M1 through the hole in the front panel and place its mounting clip over the meter while holding the meter securely against the panel. Push the mounting clip tightly against the panel.
194. (✓) Connect a 5-1/2-inch length of red wire under the positive (+) terminal screw on meter M1.
195. (✓) Connect a 5-1/2-inch length of black wire under the negative (-) terminal screw on meter M1.
196. (✓) Cut both leads of a 100 mfd, 12V, electrolytic capacitor, C22, to 1-1/2-inch lengths. Connect the positive (+) lead under the positive (+) terminal screw on meter M1 and connect the other lead under the negative (-) terminal screw on meter M1. Rest the capacitor on top of meter M1.
197. (✓) Install the two pin jacks, J1 and J2, on the front panel. The red pin jack J2 mounts toward the top of the panel and the black pin jack J1 mounts below J2. Use hardware furnished with jacks.
198. (✓) Insert the red pilot lamp LM1 through its hole in the front panel and place its mounting clip over the pilot lamp. While holding the pilot lamp securely against the panel, push the mounting clip tightly against the panel.
199. (✓) Insert the clear modulation indicator lamp LM2 through its hole in the front panel and mount as in step 198.
200. (✓) Connect and solder a 2-inch length of No. 22 bare tinned wire to each lead of LM2, should leads be less than 1-5/8 inches long.
201. (✓) Cut two 1-1/4-inch lengths of sleeving and slip one length over each lead of LM2.
202. (✓) Remove the black palnuts from the function switch S3 and the bandswitch S2. While holding S3 in place, mount the front panel assembly onto the chassis by inserting the function switch shaft and other switch shafts through their respective clearance holes in the panel. Replace and finger tighten the palnuts.
203. (✓) Install the key jack J3 in chassis hole 57 so that the arm is toward the right side of the unit as shown in pictorial 6. Secure with a 3/8-inch, nickel-plated flat washer and hex nut, use a 3/8-inch lockwasher between the jack and the panel as shown in pictorial 6. Tighten all 3/8-inch hex nuts mounting the front panel.
204. (✓) Connect one lead from the modulation indicator LM2 to terminal 1 of terminal strip TS19 (S-2) and connect the other lead to terminal 2 of terminal strip TS19 (S-1). Refer to pictorials 5 and 6.

FINAL ASSEMBLY AND WIRING

(Refer to Pictorials 7 and 8 and Figures 14, 15, 16, and 17)

205. (✓) Pass the red and black leads from the meter through chassis hole 59 and connect the red lead to terminal 4 of slide switch S4 (S-1). Connect the black lead to terminal 3 of switch S4 (S-1).
206. (✓) Cut two 1-1/2-inch lengths of sleeving and place one length on each lead of the pilot lamp LM1. Pass these leads through chassis hole 58 and connect one lead to terminal 1 of terminal strip TS4 (S-2). Connect the other lead to terminal 2 of terminal strip TS4 (S-2).
207. (✓) Connect a 2-inch length of red wire from terminal 3a of function switch S3 (S-1) to terminal 1 of terminal strip TS15 (S-3).
208. (✓) Connect a 5-inch length of red wire from terminal 2 of switch S3 (S-1) to terminal 3 of terminal strip TS15 (S-2).
209. (✓) Cut two 3/4-inch lengths of sleeving, place one length on each lead of a 68K-ohm, 1/2-watt resistor, R29, and trim both leads so that only 3/8 inch remains beyond the sleeving. Connect one lead to terminal 3 of switch S3 (S-2) and connect the other lead to terminal 12 of switch S3 (DS).
210. (✓) Cut a 1-1/8-inch length of sleeving, place it over one lead of the NE-2H neon lamp N1, and trim this lead so that only 1/4 inch remains beyond the sleeving. Connect this lead to terminal 12 of switch S3 (S-2). Cut the other lead to a 3/4-inch length and connect it to terminal 4 of terminal strip TS15 (S-2).
211. (✓) Connect the black wire from chassis hole X to terminal 1 on the AC snap-switch at the rear of switch S3 (S-2).
212. (✓) Connect a 7-inch length of white wire from terminal 4 on wafer "B" of bandswitch S2 (DS) to terminal 5 of tube socket XV2 (S-2).
213. (✓) Cut one lead of the 6-meter grid coil L8 to 1/2-inch length and the other lead to a 1-inch length. Connect the 1/2-inch lead to terminal 3 on wafer "A" of switch S2 (S-1). Pass the other lead through terminal 3 on wafer "B" of switch S2 (DS) and connect it to terminal 4 on wafer "B" of switch S2 (S-2).
214. (✓) Cut one lead of the 10-meter grid coil L7 to a 1/2-inch length and the other lead to a 1-inch length. Connect the 1/2-inch lead to terminal 2 on wafer "A" of switch S2 (S-1). Pass the other lead through terminal 2 on wafer "B" of switch S2 (DS) and connect it to terminal 3 on wafer "B" of switch S2 (S-3).
215. (✓) Cut one lead of the 15-meter grid coil L6 to a 1/2-inch length and the other lead to a 1-inch length. Connect the 1/2-inch lead to terminal 1 on wafer "A" of switch S2 (S-1). Pass the other lead through terminal 1 on wafer "B" of switch S2 (S-2) and connect it to terminal 2 on wafer "B" of switch S2 (S-2).
216. () Locate and install the 25-MC filter FR1 on the side of tube socket XV2 mounting bracket by soldering it in place as shown in figure 16.
217. (✓) Connect a short piece of No. 22 bare tinned wire from terminal 6 on wafer "C" of bandswitch S2 (S-1) to the solder lug at the foot of the bandswitch S2 mounting bracket (DS).
218. (✓) Connect the outer conductor (shield braid) of the black, precut, RG-58/U cable to the solder lug at the foot of the bandswitch S2 mounting bracket (S-2).
219. (✓) Connect the center conductor at this end of the cable to terminal 7 on wafer "C" of switch S2 (DS).
220. (✓) Connect the outer conductor (shield braid) from the other end of this cable to the solder lug at chassis hole 45 (S-1).

221. (✓) Connect the center conductor at this end of the cable to terminal 2 of the 25-MC filter assembly (S-3).
222. (✓) Connect the bare tinned lead from terminal 1 of the 25-MC filter assembly to terminal 1 of the coaxial connector J5 (DS).
223. (✓) Cut both leads of a 5.6K-ohm, 1-watt resistor, R23, to 1/2-inch lengths. Connect one lead to terminal 1 of connector J5 (S-2) and connect the other lead to terminal 3 of terminal strip TS18 (S-3). CAUTION: WHEN SOLDERING THIS CONNECTION USE A HEAT SINK ON THE DIODE. REFER TO STEP 8 OF SOLDERING TECHNIQUES. (DO NOT OVERHEAT.)
224. (✓) Connect the free lead of the 100 mfd capacitor, C26, to terminal 5 on wafer "C" of bandswitch S2 (S-1) as shown in figure 14.
225. (✓) Cut a 2-3/8-inch length of sleeving and place on lead 6 of the tank coil L10. Connect this lead to terminal 7 on wafer "C" of switch S2 (S-2).
226. (✓) Cut a 2-3/4-inch length of sleeving and place on lead 5 of the tank coil L10. Connect this lead to terminal 8 on wafer "C" of switch S2 (S-1).
227. (✓) Cut a 3-3/8-inch length of sleeving and place on lead 4 of the tank coil L10. Connect this lead to terminal 9 on wafer "C" of switch S2 (S-1).
228. (✓) Cut a 3-3/4-inch length of sleeving and place it on lead 3 of the tank coil L10. Pass this lead through terminal 10 on wafer "C" of switch S2 (S-1) and connect it to terminal 11 on wafer "C" of switch S2 (S-1).
229. (✓) Cut a 4-1/4-inch length of sleeving and place it on lead 2 of the tank coil L10. Connect this lead to terminal 12 on wafer "C" of switch S2 (S-1).
230. (✓) Mount the bandswitch shield over wafer "C" of switch S2 with two No. 6 x 1/4 inch thread-forming screws as shown in figure 17.
231. (✓) Cut both leads of a .001 mfd, 1000V, ceramic disc capacitor, C28, to 5/8-inch lengths. Connect one lead to terminal 1 of terminal strip TS13 (S-2). Connect the other lead to terminal 3 of terminal strip TS13 (S-2).
232. (✓) Cut both leads of a 100 mfd, 1000V, ceramic disc capacitor, C29, to 1/2-inch lengths. Connect one lead to GND Lug 2 of tube socket XV3 (S-2) and connect the other lead to terminal 2 of tube socket XV3 (S-3).
233. (✓) Cut both leads of a .001 mfd, 1000V, ceramic disc capacitor, C30, to 1/2-inch lengths. Connect one lead to GND Lug terminal 1 of tube socket XV3 (S-2) and connect the other lead to terminal 1 of tube socket XV3 (DS).
234. (✓) Cut both leads of a .005 mfd, 500V, ceramic disc capacitor, C31, to 1/2-inch lengths. Connect one lead to terminal 1 of tube socket XV3 (DS). Connect the other lead to terminal 4 of terminal strip TS12 (S-2).
235. (✓) Cut both leads of a 470K-ohm, 1/2-watt resistor, R15, to 5/8-inch lengths. Connect one lead to terminal 2 of terminal strip TS11 (DS) and connect the other lead to terminal 1 of tube socket XV3 (S-3).
236. (✓) Cut both leads of a 470K-ohm, 1/2-watt resistor, R17, to 5/8-inch lengths. Connect one lead to terminal 2 of terminal strip TS11 (S-4) and connect the other lead to terminal 6 of tube socket XV3 (S-2).
237. (✓) Cut both leads of a .005 mfd, 500V, ceramic disc capacitor, C11, to 1/2-inch lengths. Connect one lead to GND Lug 3 of tube socket XV1 (S-4) and connect the other lead to terminal 6 of tube socket XV1 (DS).

238. (✓) Cut two 1-1/8-inch lengths of sleeving, place one length on each lead of an 470-ohm, 1/2-watt resistor, R5, and trim both leads so that only 3/8 inch remains beyond the sleeving. Connect one lead to terminal 3 of terminal strip TS9 (S-4) and connect the other lead to terminal 6 of tube socket XV1 (S-2).
239. (✓) Connect a 3-3/4-inch length of green wire from the tip jack J1 (DS) to terminal 2 of tube socket XV1 (S-3).
240. (✓) Connect a short piece of No. 22 bare tinned wire from tip jack J2 (S-1) to terminal 5 of terminal strip TS9 (S-2).
241. (✓) Cut both leads of a .005 mfd, 500V, ceramic disc capacitor, C48, to 3/4-inch lengths. Connect one lead to tip jack J1 (S-2) and connect the other lead to terminal 3 of slide switch S1 (S-1).
242. (✓) Connect a 6-inch length of white/black wire from terminal 2 of slide switch S1 (S-2) to terminal 2 of key jack J3 (DS).
243. (✓) Connect the white/black wire from WH-2n to terminal 2 of key jack J3 (S-2).
244. (✓) Connect a 1-3/4-inch length of violet wire from terminal 3 of key jack J3 (S-1) to terminal 2 of terminal strip TS10 (S-3).
245. (✓) Connect a 1-1/2-inch length of black wire from terminal 2 of slide switch S4 (DS) to terminal 3 of terminal strip TS10 (S-2).
246. (✓) Connect one end of a 1-1/4-inch length of No. 22 bare tinned wire to terminal 2 of slide switch S4 (DS). Slip a 1/2-inch length of sleeving on this wire and connect the other end to terminal 6 of slide switch S4 (DS).
247. (✓) Cut both leads of a .001 mfd, 1000V, ceramic disc capacitor, C16, to 1/2-inch lengths. Connect one lead to terminal 2 of slide switch S4 (S-3) and connect the other lead to terminal 1 of slide switch S4 (S-2).
248. (✓) Cut both leads of a .001 mfd, 1000V, ceramic disc capacitor, C21, to 1/2-inch lengths. Connect one lead to terminal 5 of slide switch S4 (DS) and connect the other lead to terminal 6 of slide switch S4 (DS).
249. (✓) Cut both leads of a 10K-ohm, 1/2-watt resistor, R10, to 5/8-inch lengths. Connect one lead to terminal 5 of slide switch S4 (S-3) and connect the other lead to terminal 6 of slide switch S4 (S-3).
250. (✓) Cut both leads of a .47 mfd, 400V, molded mylar capacitor, C36, to 1-inch lengths. Connect one lead to terminal 1 of terminal strip TS10 (S-3) and connect the other lead to terminal 5 of terminal strip TS10 (DS).
251. (✓) Cut both leads of a 12K-ohm, 2-watt resistor, R20, to 1-1/2-inch lengths. Connect one lead to terminal 5 of terminal strip TS10 (S-3) and connect the other lead to terminal 9 of tube socket XV4 (S-4).
252. (✓) Cut both leads of a .001 mfd, 1000V, ceramic disc capacitor, C20, to 1/2-inch lengths. Connect one lead to GND Lug 4 of tube socket XV2 (DS) and connect the other lead to terminal 7 of tube socket XV2 (S-3).
253. (✓) Cut both leads of a .001 mfd, 1000V, ceramic disc capacitor, C27, to 1/2-inch lengths. Connect one lead to GND Lug 4 of tube socket XV2 (S-2) and connect the other lead to terminal 8 of tube socket XV2 (S-2).
254. (✓) Cut both leads of a 100-ohm, 5-watt resistor, R31, to 5/8-inch lengths. Connect one end to terminal 3 of tube socket XV2 (S-2) and connect the other lead to terminal 1 of terminal strip TS5 (S-2).

255. (✓) Install the line cord lock on the line cord PL1 2 inches behind the tinned ends. Insert the tinned ends of the cord through chassis hole 54 and press the line cord lock into this hole until the shoulder of the lock is against the chassis as shown in figure 15.
256. (✓) Connect one lead from PL1 to terminal 1 of terminal strip TS17 (DS). Connect the other lead to terminal 3 of terminal strip TS17 (DS).
257. (✓) Cut both leads of an AC line filter, L15, to 3/4-inch lengths. Connect one lead to terminal 1 of terminal strip TS16 (S-3) and connect the other lead to terminal 1 of terminal strip TS17 (S-3).
258. (✓) Cut both leads of an AC line choke, L14, to 3/4-inch lengths. Connect one lead to terminal 3 of terminal strip TS16 (S-4) and connect the other lead to terminal 3 of terminal strip TS17 (S-3).

This completes the wiring of the HT-40K MK I.

FINAL MECHANICAL INSTALLATIONS

(Refer to Pictorial 5 and 6 and Figure 13 and 18)

259. (✓) Insert the two No. 8 x 3/16 inch set screws into the tapped holes on the side of the two large plastic knobs. Mount the metal knob skirts so that the scale graduations are facing the knobs using three No. 2 x 3/16 inch machine screws on each knob as shown in figure 18.
260. (✓) Rotate the plate loading capacitor C25 and plate tuning capacitor C17 fully counterclockwise. Mount one of the above knobs on each capacitor shaft so that the 100 mark on the skirt is in line with the indicator mark on the panel. Tighten the set screws.
261. () Insert the remaining No. 8 x 3/16 inch set screws into the remaining plastic knobs.
262. (✓) Rotate the driver tuning capacitor C15 fully counterclockwise. Mount the plastic knob with one set screw on the capacitor's shaft so that the red line is in line with the first dot (dot on the left side) on the front panel. Tighten the set screw.
263. (✓) Rotate the function switch S3 fully counterclockwise. Mount one of the remaining knobs on the switch shaft so that the red line is in line with the "OFF" on the panel. Tighten the set screws.
264. (✓) Rotate the bandswitch S2 fully counterclockwise. Mount the remaining knob on the switch shaft so that the red line is in line with the 80 on the panel. Tighten the set screws.
265. (✓) Install the tubes in their respective sockets and the tube shields on the required tubes, as shown in pictorial 5.
- | | | | |
|----|------------|------------|-----------------|
| V1 | 6CX8 Tube | Socket XV1 | Use Tube Shield |
| V2 | 6DQ5 Tube | Socket XV2 | |
| V3 | 12AX7 Tube | Socket XV3 | Use Tube Shield |
| V4 | 6DE7 Tube | Socket XV4 | Use Tube Shield |
266. (✓) Feed the line cord through the opening in the back of the cabinet and then carefully slide the wired chassis into the cabinet from the front. Secure the chassis to the cabinet with ten No. 6 x 1/4 inch thread-forming screws.
267. (✓) Connect a piece of No. 22 bare tinned wire between screw terminals 3 and 4 on terminal board TA1.

This completes the construction of your HT-40K MK I transmitter. Refer to the operation manual for operation and installation information.

PARTS LIST

QUANTITY USED	SCHEMATIC SYMBOL	DESCRIPTION	HALLICRAFTERS PART NUMBER
10	C1, 3, 8, 10, 11, 12, 31, 39, 48, 49	Capacitor, .005 mfd, 500V, ±20%; Ceramic Disc	047-100442
3	C2, 9, 14	Capacitor, 50 mmf, 600V, 10%; Ceramic Disc	047-100744
17	C4, 5, 6, 13, 16, 20, 21, 23, 24, 27, 28, 30, 33, 40, 41, 42, 43	Capacitor, .001 mfd, 1KV, GMV; Ceramic Disc	047-101172
1	C7	Capacitor, .01 mfd, 500V, +80-20%; Ceramic Disc	047-100224
1	C15	Capacitor, Variable, Driver	048-000499
1	C17	Capacitor, Variable, Plate Tuning	048-000496
1	C18	Capacitor, .001 mfd, 3KV, 20%; Ceramic Disc	047-100397
1	C19	Capacitor, 9 mmf, 300V, 2%; Duramica	481-151090
1	C22	Capacitor, 100 mfd, 12 VDC; Electrolytic	045-100619
1	C25	Capacitor, Variable, Plate Loading	048-000519
1	C26	Capacitor, 100 mmf, 2KV, 10%; Ceramic Disc	047-001601
2	C29, 35	Capacitor, 100 mmf, 1KV, 20%; Ceramic Disc	047-001397
1	C32	Capacitor, .1 mfd, 600V, 10%; Molded Paper	499-031104
1	C34	Capacitor, .01 mfd, 1400V, GMV; Ceramic Disc	047-200752
1	C36	Capacitor, .47 mfd, 400V, 10%; Molded Mylar	046-001337
1	C37	Capacitor, .005 mfd, 1KV, 20%; Ceramic Disc	047-100523
1	C38	Capacitor, .05 mfd, 50V, Ceramic Disc	047-001144
4	C44, 45, 46, 47	Capacitor, 40 mfd, 350 WVDC; Electrolytic	045-000723
1	C50	Capacitor, 750 mmf, 300V, 2%; Duramica (Part of FR1, 25 MC Filter)	
1	C51	Capacitor, 22 mmf, 300V, 2%; Duramica (Part of FR1, 25 MC Filter)	
2	CR1, 2	Diode, Silicon Type F6	019-002634
1	CR3	Diode, Germanium Type 1N295	019-301980
1	FR1	Filter, Trap 25 MC	150-002975
1	J1	Jack, Pin (Black)	036-000295
1	J2	Jack, Pin (Red)	036-000294

QUANTITY USED	SCHEMATIC SYMBOL	DESCRIPTION	HALLICRAFTERS PART NUMBER
1	J3	Jack, Key	036-100002
1	J4	Connector, Microphone	029-100566
1	J5	Connector, Antenna (Coaxial)	010-100056
1	L1	Choke, RF 2.5 mh	053-000597
1	L2	Choke, RF 100 uh	053-000644
1	L3	Coil, Grid 80 Meters	051-003296
1	L4	Coil, Grid 40 Meters	051-003297
1	L5	Coil, Grid 20 Meters	051-003298
1	L6	Coil, Grid 15 Meters	051-003299
1	L7	Coil, Grid 10 Meters	051-003300
1	L8	Coil, Grid 6 Meters	051-003301
1	L9	Coil, Output Tank 6 Meters	051-003308
1	L10	Coil, Output Tank 80-10 Meters	051-003302
1	L11	Choke, RF 1 mh	053-000598
1	L12	Choke, Filter	056-000446
1	L13	Choke, RF Plate	053-200426
2	L14, 15	Choke, AC Line	053-000607
2	L16, 17	Coil, RF (Part of FR1, 25 MC Filter)	
1	LM1	Lamp, Pilot (Neon), red	039-000613
1	LM2	Lamp, Modulation Indicator (Neon), clear	039-000673
1	M1	Meter, RF Output and Grid Current	082-000493
1	N1	Lamp, Neon, Type NE-2H	039-000671
1	PL1	Line Cord and Plug	087-100078
1	PS1	Parasitic Suppressor	053-000645
2	R1, 4	Resistor, 100K ohm, 10%, 1/2 watt; Fixed Composition	451-252104
1	R2	Resistor, 47K ohm, 10%, 1/2 watt; Fixed Composition	451-252473
2	R3, 11	Resistor, 22K ohm, 10%, 2 watt; Fixed Composition	451-652223
1	R5	Resistor, 470 ohm, 10%, 1/2 watt; Fixed Composition	451-252471

QUANTITY USED	SCHEMATIC SYMBOL	DESCRIPTION	HALLICRAFTERS PART NUMBER
2	R6 20	Resistor, 12K ohm, 10%, 2 watt; Fixed Composition	451-652123
1	R7	Resistor, 2500 ohm, 10%, 7 watt; Fixed, Wire Wound	024-001357
2	R8, 13	Resistor, 1 megohm, 10%, 1/2 watt; Fixed Composition	451-252105
1	R9	Resistor, 39K ohm, 10%, 1 watt; Fixed Composition	451-352393
1	R10	Resistor, 10K ohm, 10%, 1/2 watt; Fixed Composition	451-252103
1	R12	Resistor, 4.7K ohm, 10%, 1/2 watt; Fixed Composition	451-252472
1	R14	Resistor, 2.2 megohm, 10%, 1/2 watt; Fixed Composition	451-252225
3	R15, 17, 19	Resistor, 470K ohm, 10%, 1/2 watt; Fixed Composition	451-252474
1	R16	Resistor, Variable, 1 megohm, Microphone Gain	025-001949
1	R18	Resistor, 10 megohm, 10%, 1/2 watt; Fixed Composition	451-252106
1	R21	Resistor, 100K ohm, 10%, 1 watt; Fixed Composition	451-352104
1	R22	Resistor, 2.2K ohm, 10%, 1/2 watt; Fixed Composition	451-252222
1	R23	Resistor, 5.6K ohm, 10%, 1 watt; Fixed Composition	451-352562
1	R24	Resistor, 1000 ohm, 10%, 1/2 watt; Fixed Composition	451-252102
1	R25	Resistor, 56K ohm, 10%, 1/2 watt; Fixed Composition	451-252563
1	R26	Resistor, 20 ohm, 10%, 7 watt; Fixed Wire Wound	024-001356
2	R27, 28	Resistor, 56K ohm, 10%, 2 watt; Fixed Composition	451-652563
1	R29	Resistor, 68K ohm, 10%, 1/2 watt; Fixed Composition	451-252683
1	R30	Resistor, 100 ohm, 10%, 1/2 watt; Fixed Composition	451-252101
1	R31	Resistor, 100 ohm, 10%, 5 watt; Fixed Wire Wound	445-012101
1	S1	Switch, Slide, (SPDT), Crystal - VFO	060-200967

QUANTITY USED	SCHEMATIC SYMBOL	DESCRIPTION	HALLICRAFTERS PART NUMBER
1	S2	Switch, Band Selector	060-002413
1	S3	Switch, Wafer, Function	060-002417
1	S4	Switch, Slide, (DPDT), Meter	060-002260
2	SI-1, 2	Insulator, Stand-off	008-006149
1	T1	Transformer, Power	052-000852
1	TA1	Board, Terminal 4 Screw Connector	088-002411
2	TS1, 2	Terminal Strip, 4 lug (Refer to Pictorial 1)	088-200297
2	TS3,14	Terminal Strip, 3 lug (Refer to Pictorial 2)	088-200305
1	TS4	Terminal Strip, 4 lug (Refer to Pictorial 2)	088-200344
1	TS5	Terminal Strip, 1 lug (Refer to Pictorial 3)	088-200384
1	TS6	Terminal Strip, 2 lug (Refer to Figure 8)	088-200352
2	TS7, 11	Terminal Strip, 2 lug (Refer to Pictorial 2)	088-200292
1	TS8	Terminal Strip, 4 lug (Refer to Pictorial 2)	088-200297
1	TS9	Terminal Strip, 5 lug (Refer to Pictorial 2)	088-200348
1	TS10	Terminal Strip, 5 lug (Refer to Pictorial 2)	088-200287
1	TS12	Terminal Strip, 4 lug (Refer to Pictorial 1)	088-202235
1	TS13	Terminal Strip, 4 lug (Refer to Pictorial 1)	088-200344
1	TS15	Terminal Strip, 4 lug (Refer to Pictorial 2)	088-200312
2	TS16, 17	Terminal Strip, 3 lug (Refer to Pictorial 2)	088-301145
1	TS18	Terminal Strip, 3 lug (Refer to Pictorial 2)	088-301145
1	TS19	Terminal Strip, 2 lug (Refer to Pictorial 5)	088-200352
1	V1	6CX8, Crystal Oscillator, Driver	090-901418
1	V2	6DQ5, Final Amplifier	090-901420
1	V3	12AX7, 1st and 2nd Audio Amplifier	090-900038
1	V4	6DE7, 3rd Audio Amplifier, Modulator, Regulator	090-901419
3	XV1, 3, 4	Socket, Tube, 9 Pin Miniature	006-000947
1	XV2	Socket, Tube, 8 Pin Octal	006-000948
MISCELLANEOUS			
1		Bracket, Tube Mounting	067-008881
1		Cabinet	150-901138

QUANTITY USED	DESCRIPTION	HALLICRAFTERS PART NUMBER
1	Chassis, HT-40K, MK I	070-002107
1	Clip, Meter (Supplied with Meter)	
1	Clip, Pilot Lamp (Supplied with Lamp)	
1	Clip, Modulation Indicator Lamp (Supplied with Lamp)	
2	Knob, Plate Tuning and Loading	015-001735
2	Knob, Plastic (2 set screws)	015-001725
1	Knob, Plastic (1 set screw)	015-001724
1	Lock, Line Cord (Male and Female Sections)	076-200397
3	Lug, Solder, # 4 Internal Tooth	011-200064
3	Lug, Solder, # 6 Internal Tooth	011-100054
1	Lug, Solder, 3/8 inch flat (Supplied with Microphone Connector)	
27	Nut, # 4 Hexagon	401-023222
7	Nut, # 6 Hexagon	401-045222
2	Nut, # 6 Kep	002-102188
1	Nut, 3/8 inch Cadmium Plated Hexagon (Supplied with Microphone Connector)	
1	Nut, 3/8 inch Cadmium Plated, Pal	002-101032
1	Nut, 3/8 inch Nickle Plated, Hexagon	002-100806
2	Nut, 3/8 inch Black, Pal	002-102142
1	Panel, Front	068-001232
6	Screw, # 2 x 3/16 inch Machine	406-011312-03
4	Screw, # 4 x 1/4 inch Flat Head	406-023212-04
27	Screw, # 4 x 5/16 inch Sems	413-023312-05
2	Screw, # 6 x 1/4 inch Flat Head	406-045212-04
12	Screw, # 6 x 1/4 inch Thread Forming	416-040331-04
13	Screw, # 6 x 3/8 inch Sems	413-045312-06
1	Screw, # 6 x 1/2 inch Sems	413-045312-08
6	Screw, # 6 x 1 inch Sems	413-045312-16
9	Screw, # 8 x 3/16 inch Set	003-100973

QUANTITY USED	DESCRIPTION	HALLICRAFTERS PART NUMBER
1	Shield, Bandswitch	069-001402
3	Shield, Tube Socket Base	069-001417
3	Shield, Tube	069-100430
2	Skirt, Knob	083-000782
35 in.	Sleeving, Yellow	065-200403
150 in.	Solder, Rosin Core	033-100654
6	Spacer, 3/4 inch Brass	073-003691
26	Lockwasher, #4 Internal Tooth	426-001343
6	Lockwasher, #6 Internal Tooth	426-001543
2	Lockwasher, 3/8 inch Internal Tooth	004-002219
1	Lockwasher, 1/2 inch Internal Tooth	427-001422
8	Washer, #6 Flat	426-003543
4	Washer, #6 Fiber	004-200522
1	Washer, #6 x 3/8 inch Fiber	004-002450
1	Washer, 3/8 inch Flat (Nickle Plated)	004-100133
6 in.	Wire, White/Black No. 22, Solid	087-104930
20 in.	Wire, Black, No. 22, Solid	087-104115
20 in.	Wire, Red, No. 22, Solid	087-104117
4 in.	Wire, Yellow, No. 22, Solid	087-104119
4 in.	Wire, Green, No. 22, Solid	087-104120
4 in.	Wire, Blue, No. 22, Solid	087-104121
20 in.	Wire, Violet, No. 22, Solid	087-104122
20 in.	Wire, White, No. 22, Solid	087-104124
4 in.	Wire, Gray, No. 22, Solid	087-104123
30 in.	Wire, Tinned, No. 22, Solid	087-100723
1 length	Wire, shielded, (Precut Coaxial Cable RG-58U)	087-006889
1	Harness Cable (WH-1)	087-007167
1	Harness Cable (WH-2)	087-007168
1	Tag, Serial No. and Registration	031-003725

COLOR BAND SYSTEM EXAMPLE

Silver = 10% Tolerance
 Green = X 100000 Multiplier
 Black = 0 2nd Digit
 Brown = 1 1st Digit
 Brown=1, Black=0, Green=X 100000, Silver=10% = 1,000,000 ±10% = 1 Meg Ohm ±10%

RESISTOR CODES (RESISTANCE GIVEN IN OHMS)

COLOR	DIGIT	MULTIPLIER	TOLERANCE
BLACK	0	1	±20%
BROWN	1	10	±1%
RED	2	100	±2%
ORANGE	3	1000	±3%*
YELLOW	4	10000	GMV*
GREEN	5	100000	±5% (RETMA Alternate)
BLUE	6	1000000	±6%*
VIOLET	7	10000000	±12 1/2%*
GRAY	8	.01 (RETMA Alternate)	±30%*
WHITE	9	.1 (RETMA Alternate)	±10% (RETMA Alternate)
GOLD		.1 (JAN and RETMA Preferred)	±5% (JAN and RETMA Pref.)
SILVER		.01 (JAN and RETMA Preferred)	±10% (JAN and RETMA Pref.)
NO COLOR			±20%

RESISTOR CONVERSION CHART

2W, 1W, 1/2W, 1/4W

Ω = Ohm, K = 1000, M = 1,000,000
 Example; 2.2 Meg Ohm = 2.2 x 1,000,000 = 2,200,000

DISC CERAMICS (5-DOT SYSTEM)

DISC CERAMICS (3-DOT SYSTEM)

CERAMIC CAPACITOR CODES (CAPACITY GIVEN IN MMF)

COLOR	DIGIT	MULTIPLIER	TOLERANCE		TEMPERATURE COEFFICIENT PPM/°C	EXTENDED RANGE	
			10MMF or LESS	OVER 10MMF		TEMP. COEFF.	MULTIPLIER
BLACK	0	1	±2.0MMF	±20%	0(NPO)	0.0	-1
BROWN	1	10	±0.1MMF	±1%	-33(N033)		-10
RED	2	100		±2%	-75(N075)	1.0	-100
ORANGE	3	1000		±2.5%	-150(N150)	1.5	-1000
YELLOW	4	10000			-220(N220)	2.2	-10000
GREEN	5		±0.5MMF	±5%	-330(N330)	3.3	+1
BLUE	6				-470(N470)	4.7	+10
VIOLET	7				-750(N750)	7.5	-100
GRAY	8	.01	±0.25MMF		+30(P030)		-1000
WHITE	9	.1	±1.0MMF	±10%	General Purpose Bypass & Coupling +100(P100) (Jan)		+10000

Ceramic capacitor voltage ratings are standard 500 volts. for some manufacturers, 1000 volts for other manufacturers, unless otherwise specified.

HIGH CAPACITY TUBULAR CERAMICS (INSULATED OR NON-INSULATED)

TEMPERATURE COMPENSATING TUBULAR CERAMICS

MOLDED-INSULATED AXIAL LEAD CERAMICS

TYPOGRAPHICALLY MARKED CERAMICS

Temperature Coefficient, Capacity, Tolerance

JAN LETTER	TOLERANCE	
	10MMF or LESS	OVER 10MMF
C	±0.25MMF	
D	±0.5MMF	
F	±1.0MMF	±1%
G	±2.0MMF	±2%
J		±5%
K		±10%
M		±20%

EXTENDED RANGE T.C. TUBULAR CERAMICS

MOLDED CERAMICS Using Standard Resistor Color-Code

Distinguishes Capacitor From Resistor

DURAMICA CAPACITORS

Value And Tolerance Stamped On The Body Of Each Capacitor

FEED-THRU CERAMICS

MOLDED MICA CAPACITOR CODES (Capacity Given In MMF)

COLOR	DIGIT	MULTIPLIER	TOLERANCE	CLASS OR CHARACTERISTIC
BLACK	0	1	20%	A
BROWN	1	10	1%	B
RED	2	100	2%	C
ORANGE	3	1000	3%	D
YELLOW	4	10000		E
GREEN	5		5%(RETMA)	F(JAN)
BLUE	6			G(JAN)
VIOLET	7			H(RETMA)
GRAY	8			J(RETMA)
WHITE	9			
GOLD		.1	5%(JAN)	
SILVER		.01	10%	

MOLDED PAPER CAPACITOR CODES (Capacity Given In MMF)

COLOR	DIGIT	MULTIPLIER	TOLERANCE
BLACK	0	1	20%
BROWN	1	10	
RED	2	100	
ORANGE	3	1000	
YELLOW	4	10000	
GREEN	5	100000	5%
BLUE	6	1000000	
VIOLET	7		
GRAY	8		
WHITE	9		10%
GOLD			5%
SILVER			10%
NO COLOR			20%

COLOR BAND SYSTEM EXAMPLE

Red = 2 Voltage + Two Zeros = 200V
 Black = 20% Tolerance
 Yellow = 10,000 Multiplier
 Black = 0 2nd Digit
 Brown = 1 1st Digit
 Brown=1, Black=0, Yellow=x 10,000, Black=20%, Red=200 = 100,000 MMF ±20%
 200V = 0.1 MFD 20%, 200V

Class or characteristic denotes specifications of design involving Q factors, temperature coefficients, and production test requirements.
 All axial lead mica capacitors have a voltage rating of 300, 500, or 1000 volts, or ±1.0 MMF whichever is greater.

CURRENT STANDARD JAN AND RETMA CODE

MOLDED FLAT PAPER CAPACITORS (COMMERCIAL CODE)

MOLDED FLAT PAPER CAPACITORS (JAN CODE)

CAPACITOR CONVERSION CHART

F = Farad
 MFD = Microfarad = .000001 Farad
 MMFD = Micromicrofarad = .000001 MFD Or .000 000 000 001 Farads
 Example; 0.1 MFD = 100000 MMFD Or 0.0000001 Farads

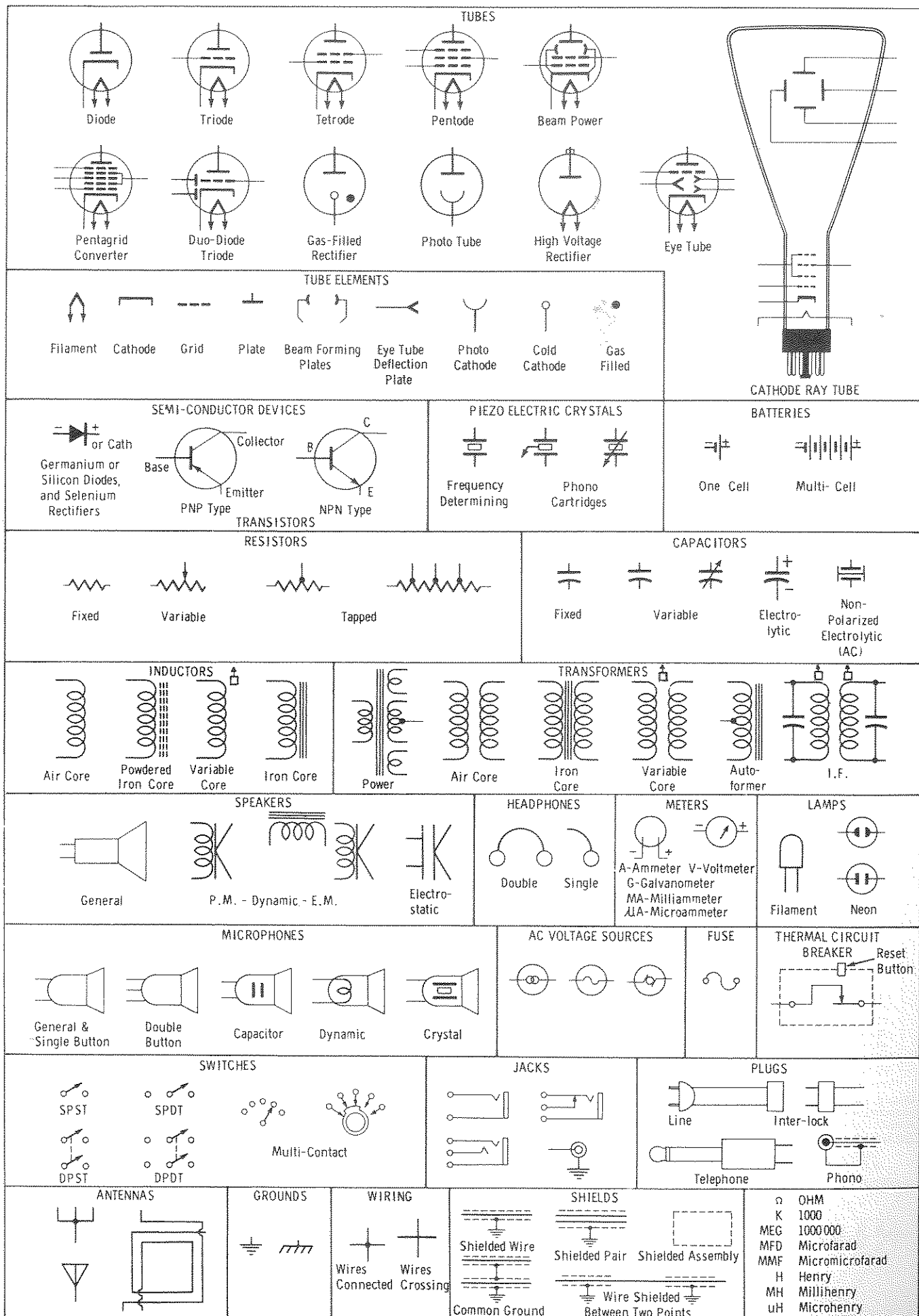

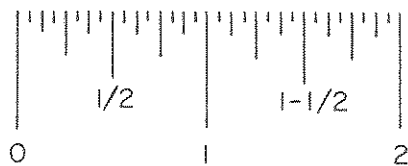

THE DIMENSION L MAY BE MEASURED BY USE OF THIS SCALE.

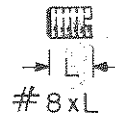

SET SCREWS

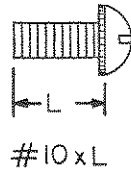
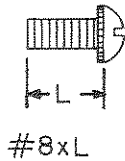
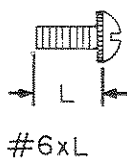
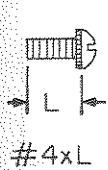

SEMS SCREWS

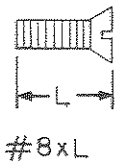
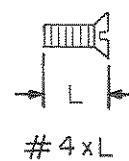

FLAT - HEAD SCREWS

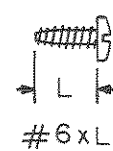
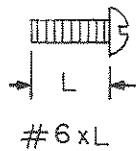
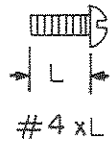

THREAD-FORMING SCREWS

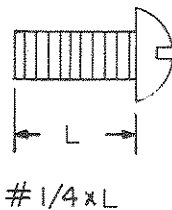
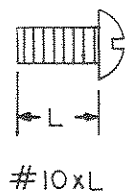
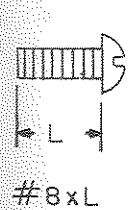

BINDING-HEAD SCREWS

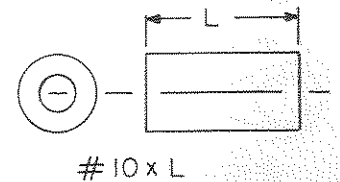
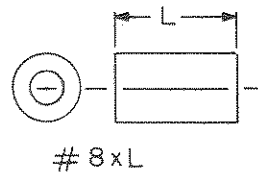
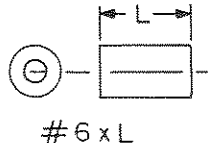
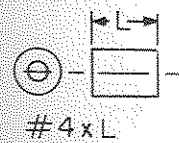

SPACERS (NOT THREADED) OR STAND-OFFS (THREADED)

092-011234-1

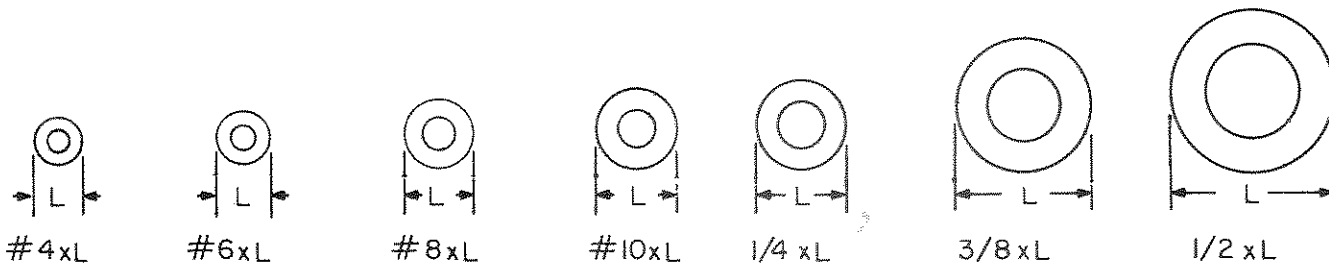

FLAT WASHERS

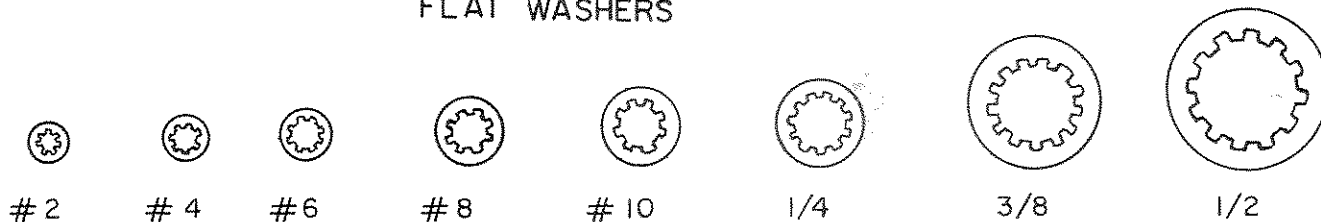

INTERNAL TOOTH LOCK WASHERS

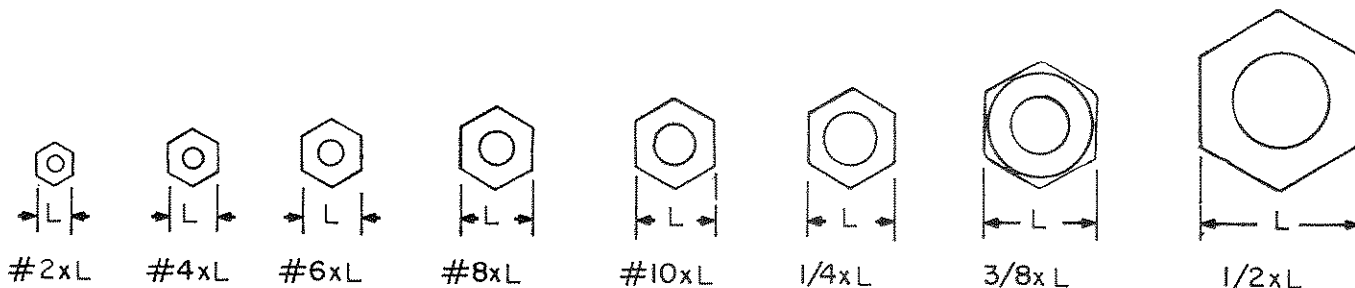

HEX NUTS

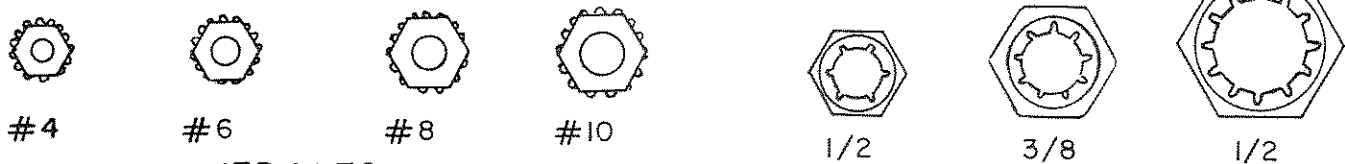

KEP NUTS

PALNUTS

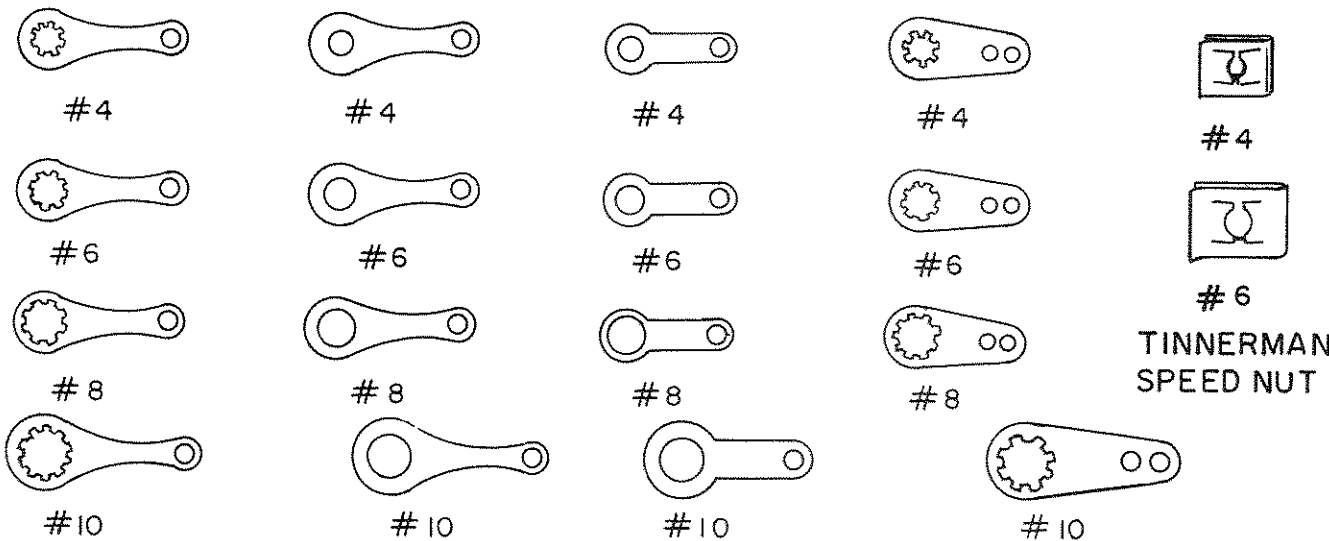

SOLDER LUGS

TINNERMAN SPEED NUT

092-011234-2

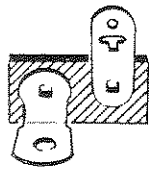

TS5

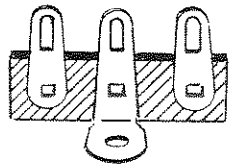

TS16, TS17, TS18

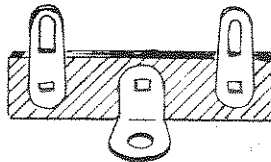

TS11, TS7

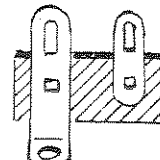

TS6, TS9

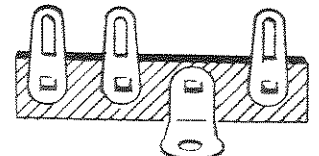

TS3, TS14

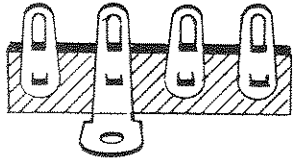

TS1, TS2, TS8

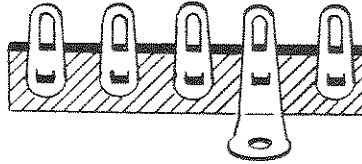

TS9

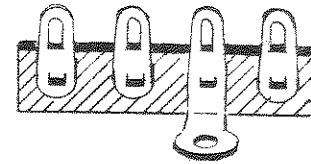

TS12

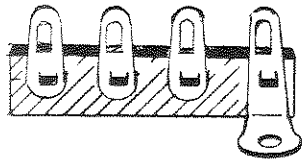

TS4, TS13

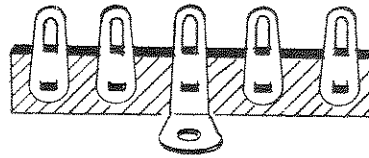

TS10

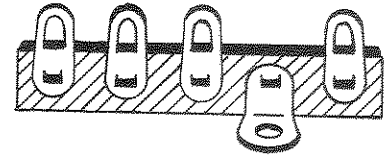

TS15

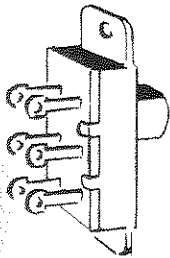

S4
DPDT

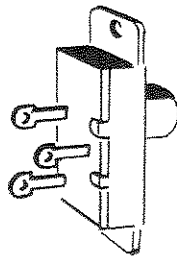

S1
SPDT

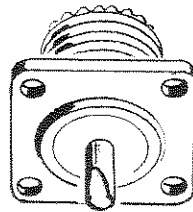

J5

ANTENNA
CONNECTOR

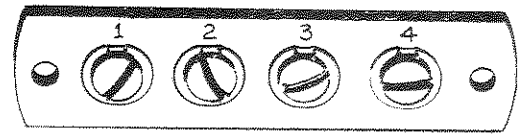

4-CONNECTOR BOARD TA1



LINE CORD LOCK

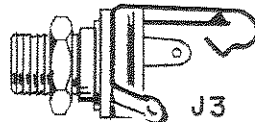

J3

KEY JACK



PILOT LAMP
MOUNTING CLIP



LMI, LM2
PILOT
LAMP

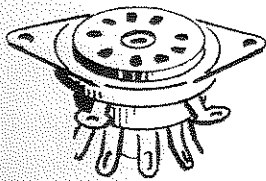

9-PIN MINIATURE
SOCKET
XV1, XV3, XV4

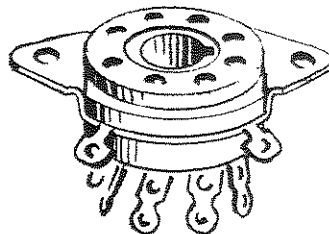

8-PIN OCTAL
SOCKET
XV2



J4

MICROPHONE
CONNECTOR



J1, J2

PIN JACK
(RED & BLACK)

092-010211B

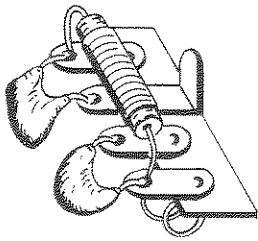

FRI

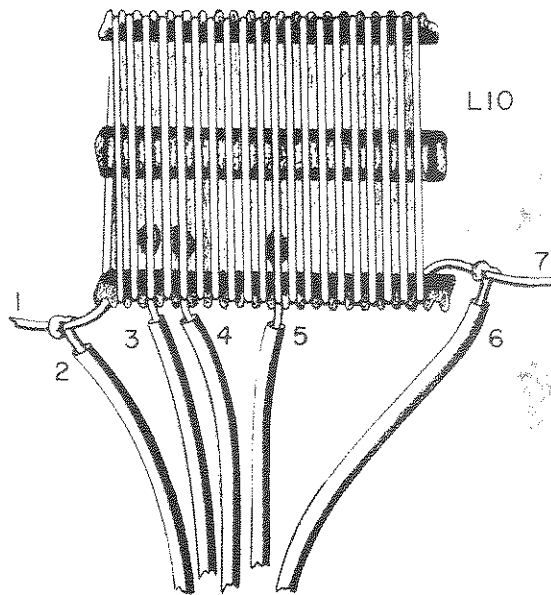

L10

OUTPUT TANK COIL 80 THRU 10 METERS

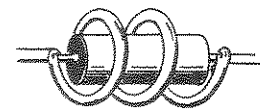

PARASITIC CHOKE
PSI



L9

OUTPUT
TANK COIL
6 METERS

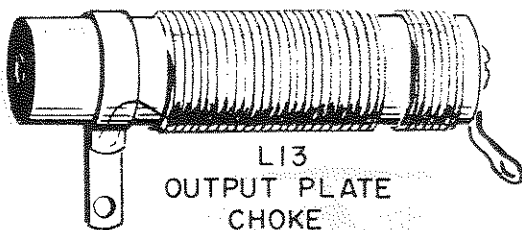

L13
OUTPUT PLATE
CHOKE

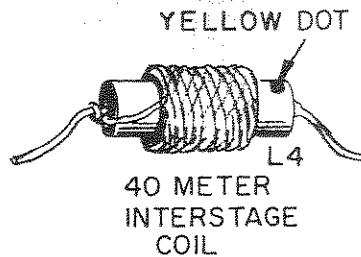

YELLOW DOT

L4
40 METER
INTERSTAGE
COIL

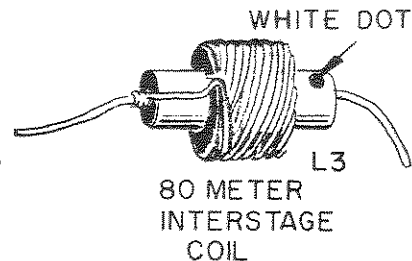

WHITE DOT

L3
80 METER
INTERSTAGE
COIL

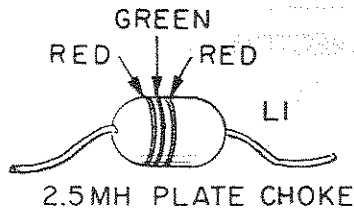

GREEN
RED RED

L1

2.5MH PLATE CHOKE

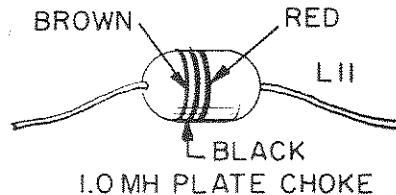

BROWN RED

L11

1.0MH PLATE CHOKE

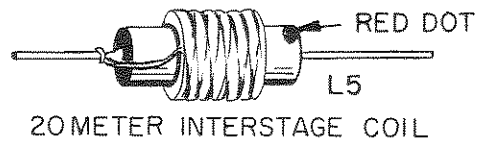

RED DOT

L5

20METER INTERSTAGE COIL

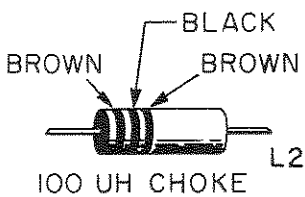

BROWN BLACK BROWN

L2

100 uH CHOKE

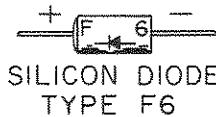

SILICON DIODE
TYPE F6

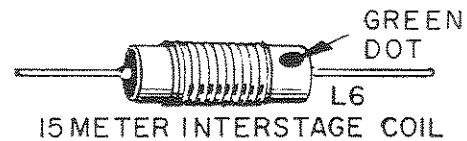

GREEN DOT

L6

15METER INTERSTAGE COIL

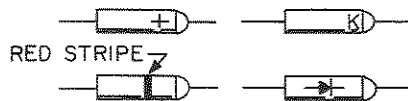

RED STRIPE

TYPES OF GERMANIUM
DIODES (TYPE IN295)
DIODES



BROWN DOT

L7

10METER INTERSTAGE COIL

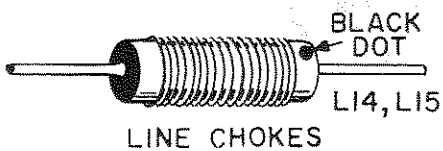

BLACK DOT

L14, L15

LINE CHOKES



BLUE DOT

L8

6 METER INTERSTAGE COIL

092-010210B

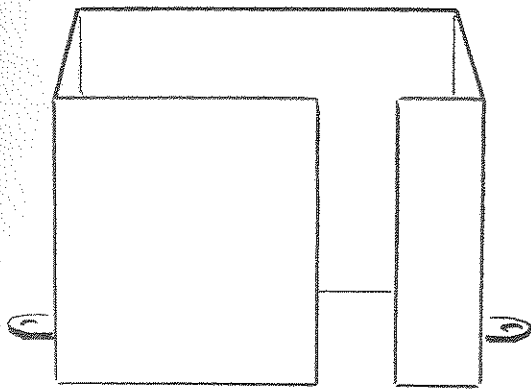

BANDSWITCH SHIELD

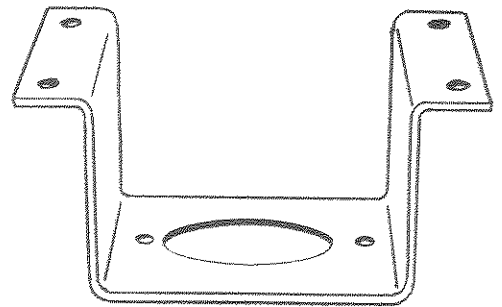

TUBE BRACKET

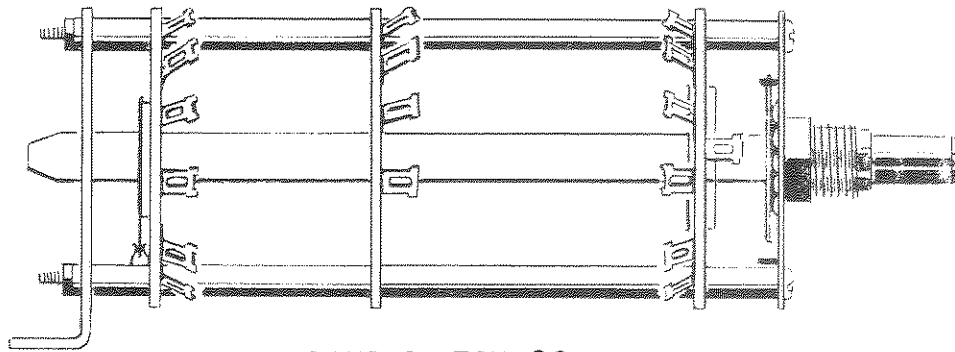

BAND SWITCH S2

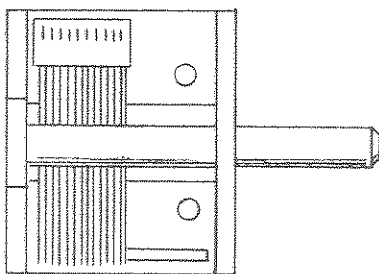

DRIVE CAPACITOR C15

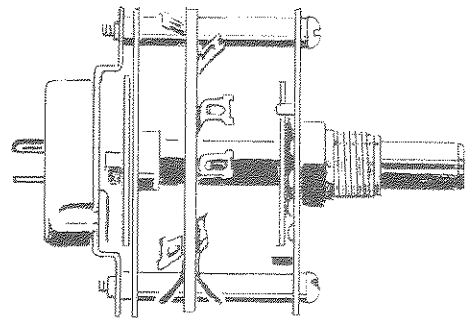

FUNCTION SWITCH S3

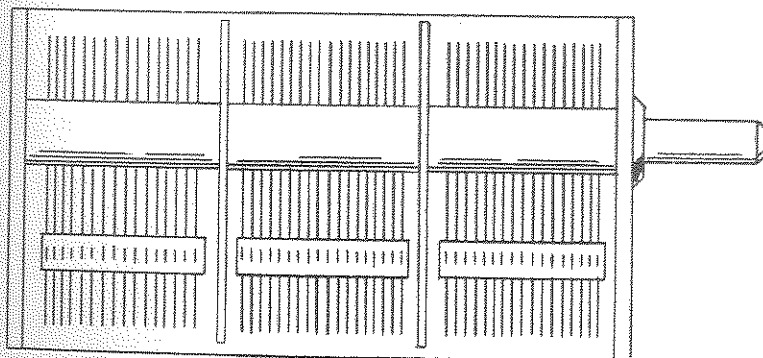

PLATE LOADING CAPACITOR
C25

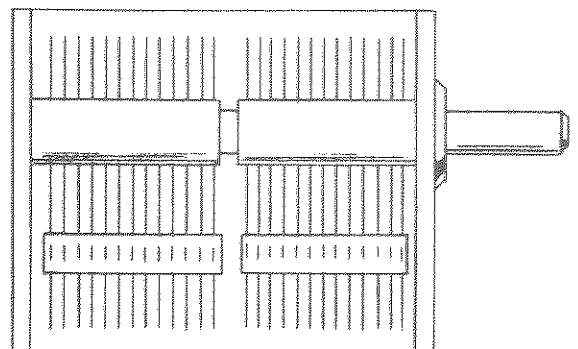
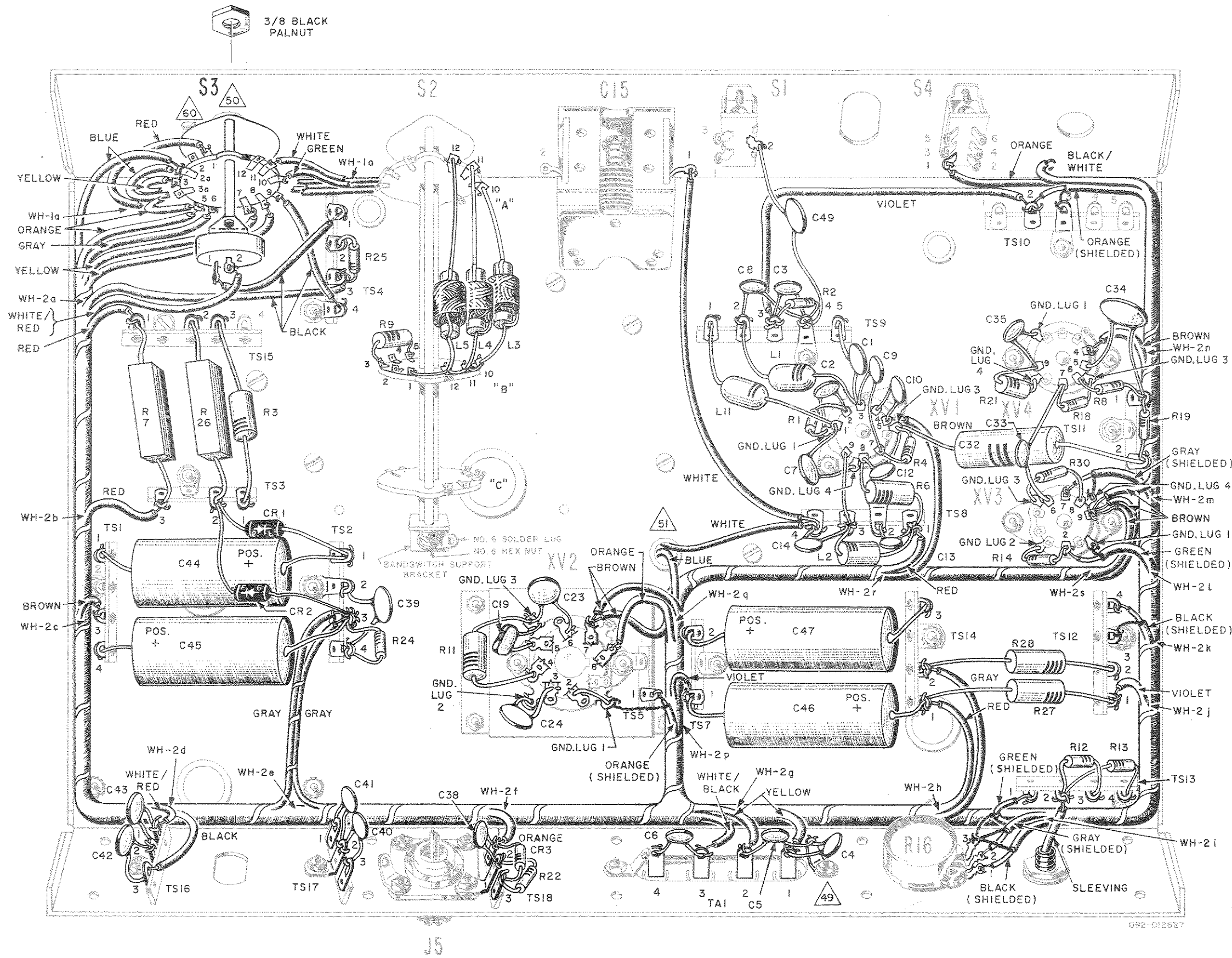

PLATE TUNING CAPACITOR
C17

092-010209B



Pictorial 4. Connecting Wiring Harness WH-2 and Components.

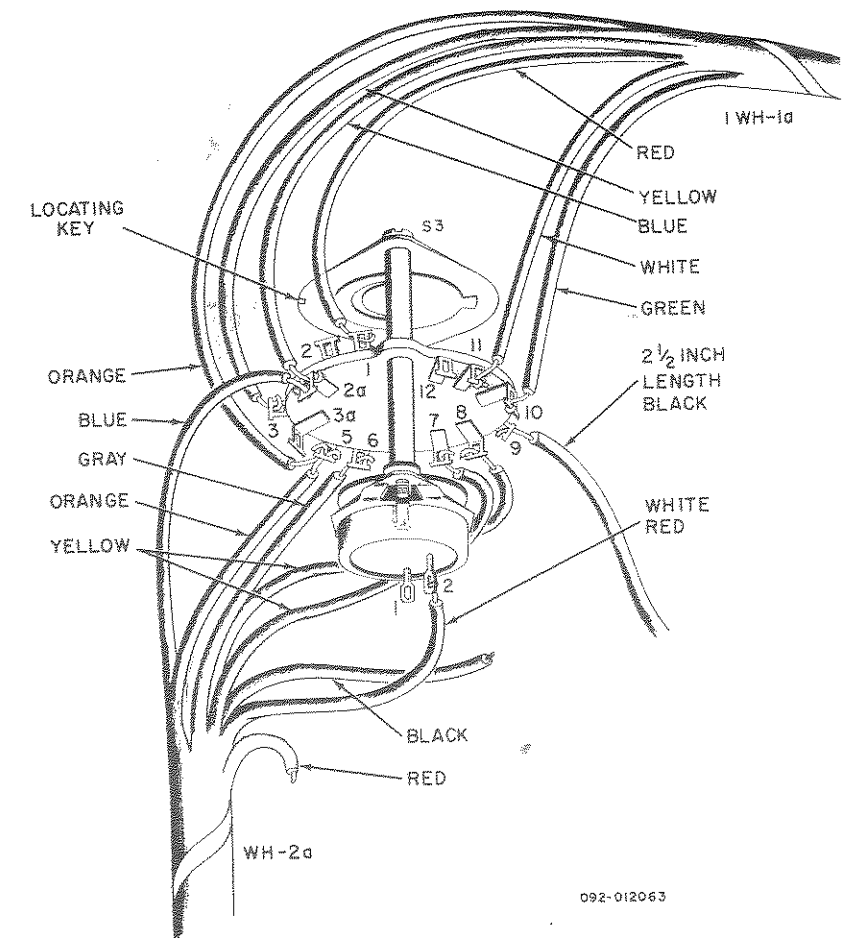

Figure 10. Wiring Switch S3.

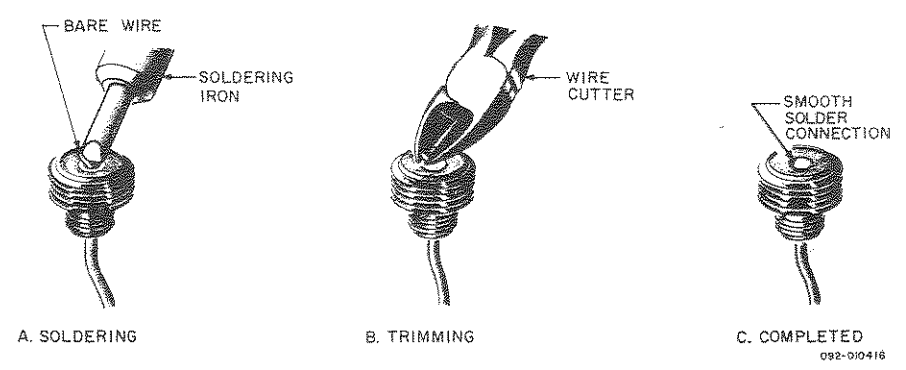

Figure 11. Wiring Microphone Connector.

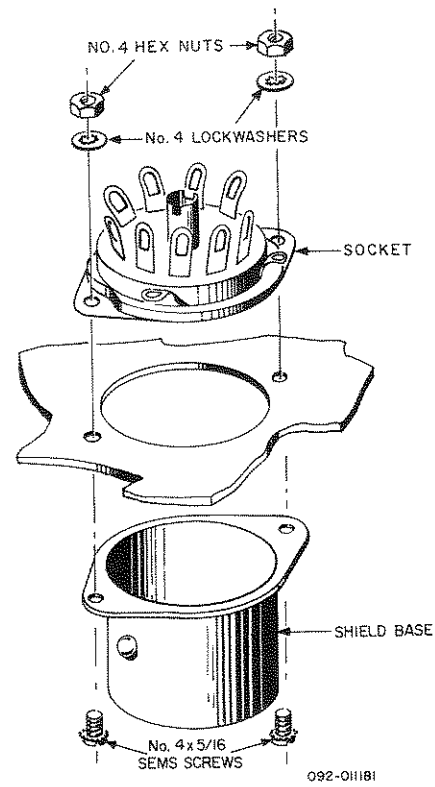

Figure 1. Tube Socket and Shield Base Mounting

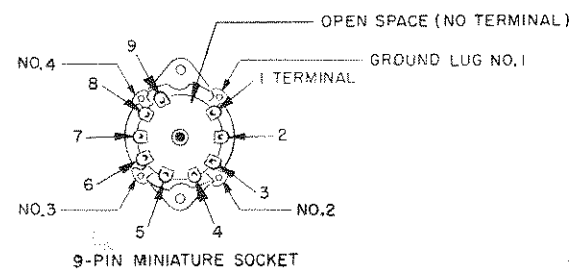

Figure 2. 9-Pin Miniature Socket.

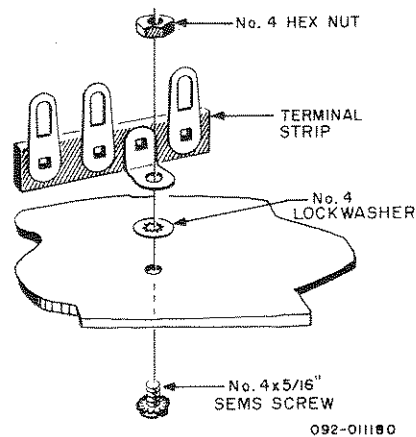
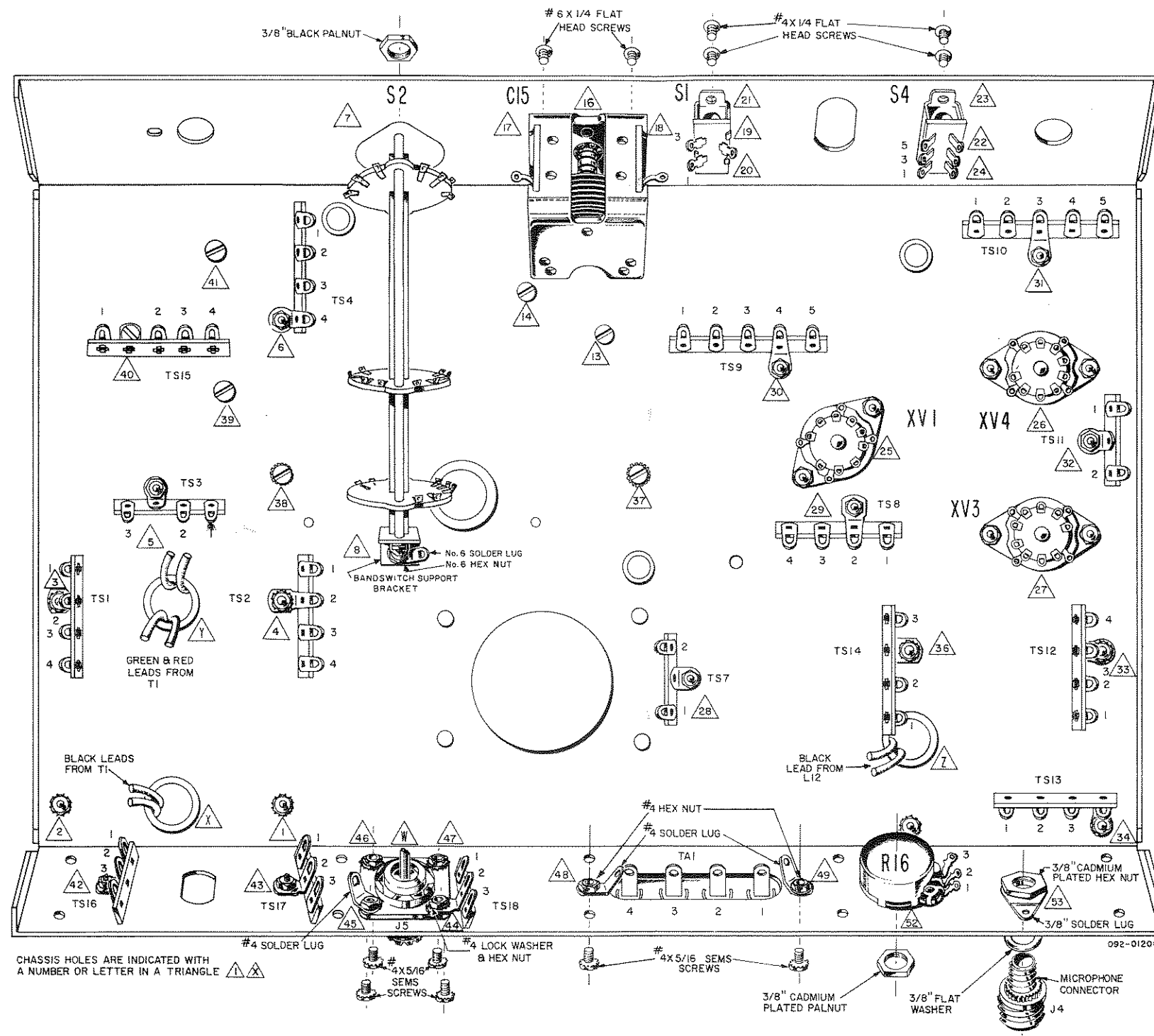

Figure 3. Terminal Strip Mounting.



Pictorial 2. Mounting Parts to the Bottom of the Chassis.

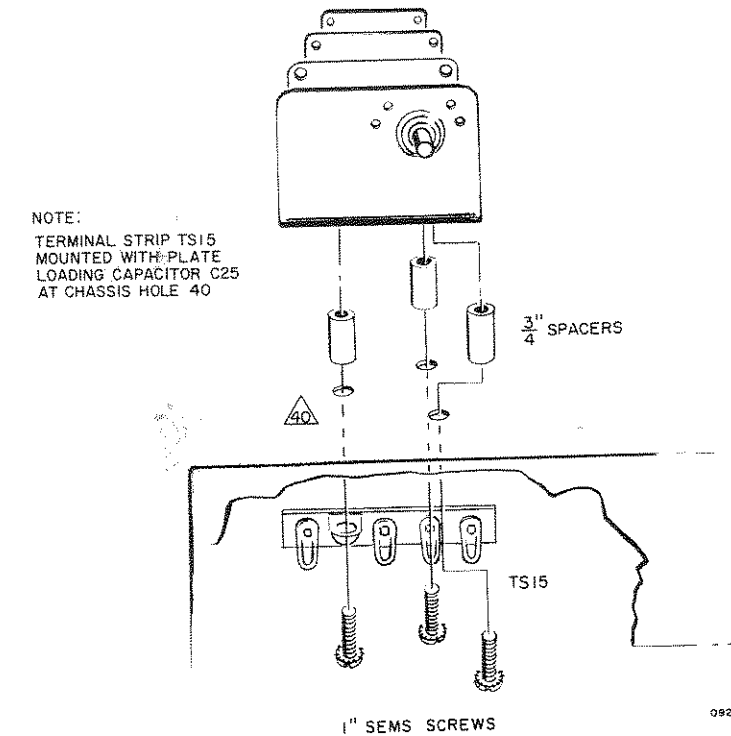

Figure 4. Plate Tuning and Loading Capacitor Mounting.

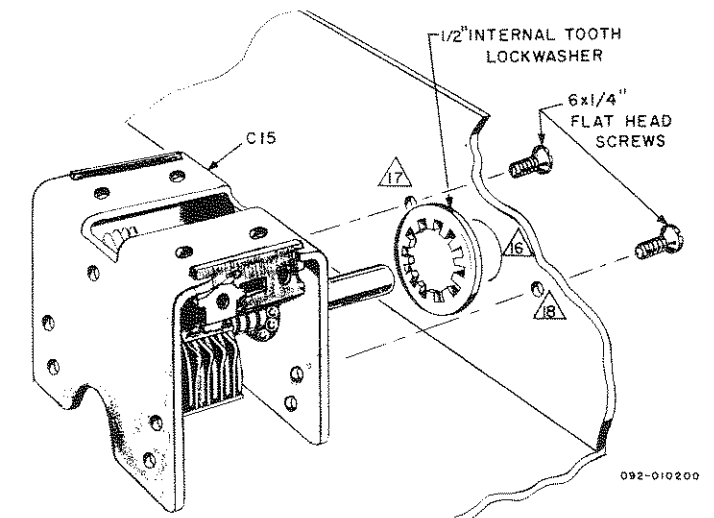

Figure 5. Drive Capacitor Mounting.

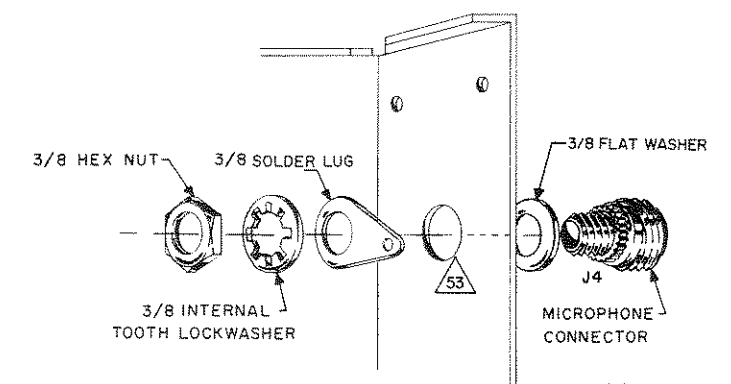
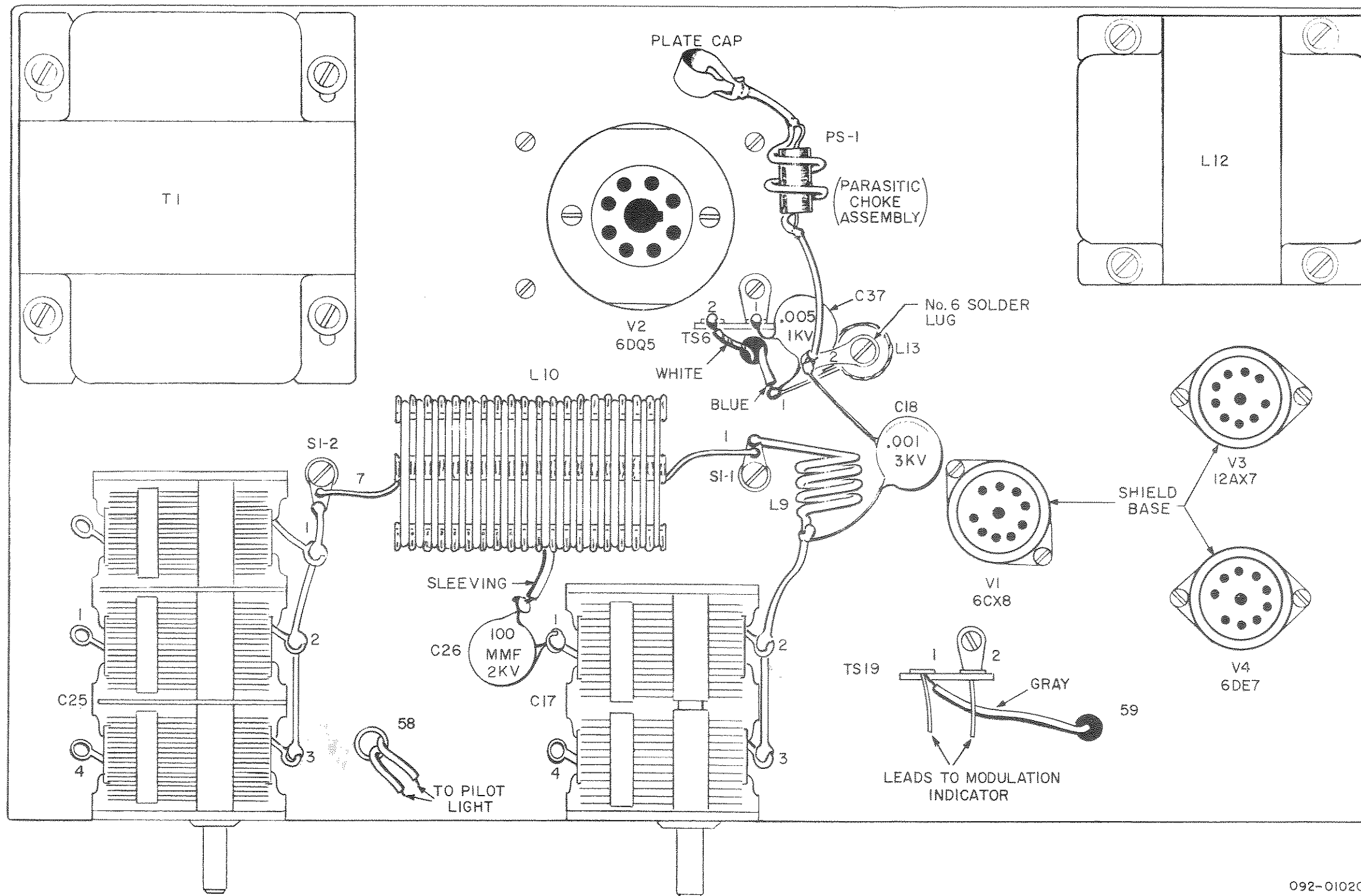

Figure 6. Mounting the Microphone Connector



Pictorial 5. Wiring Components on Top of Chassis.

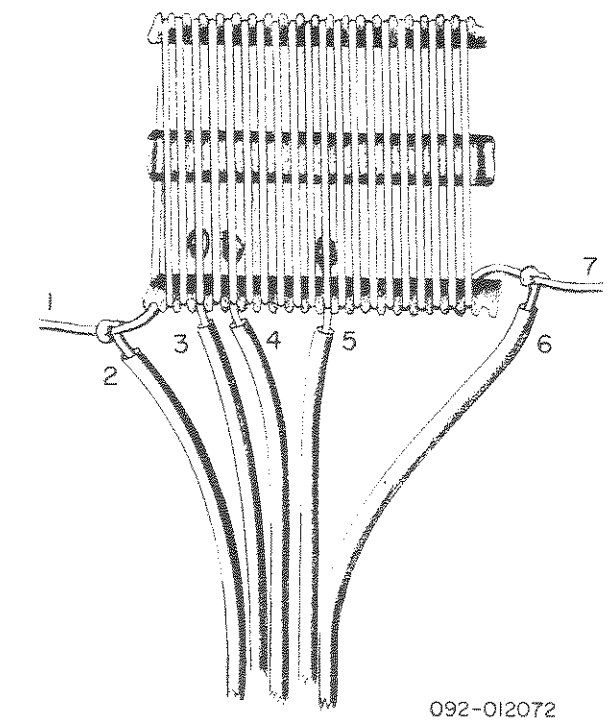
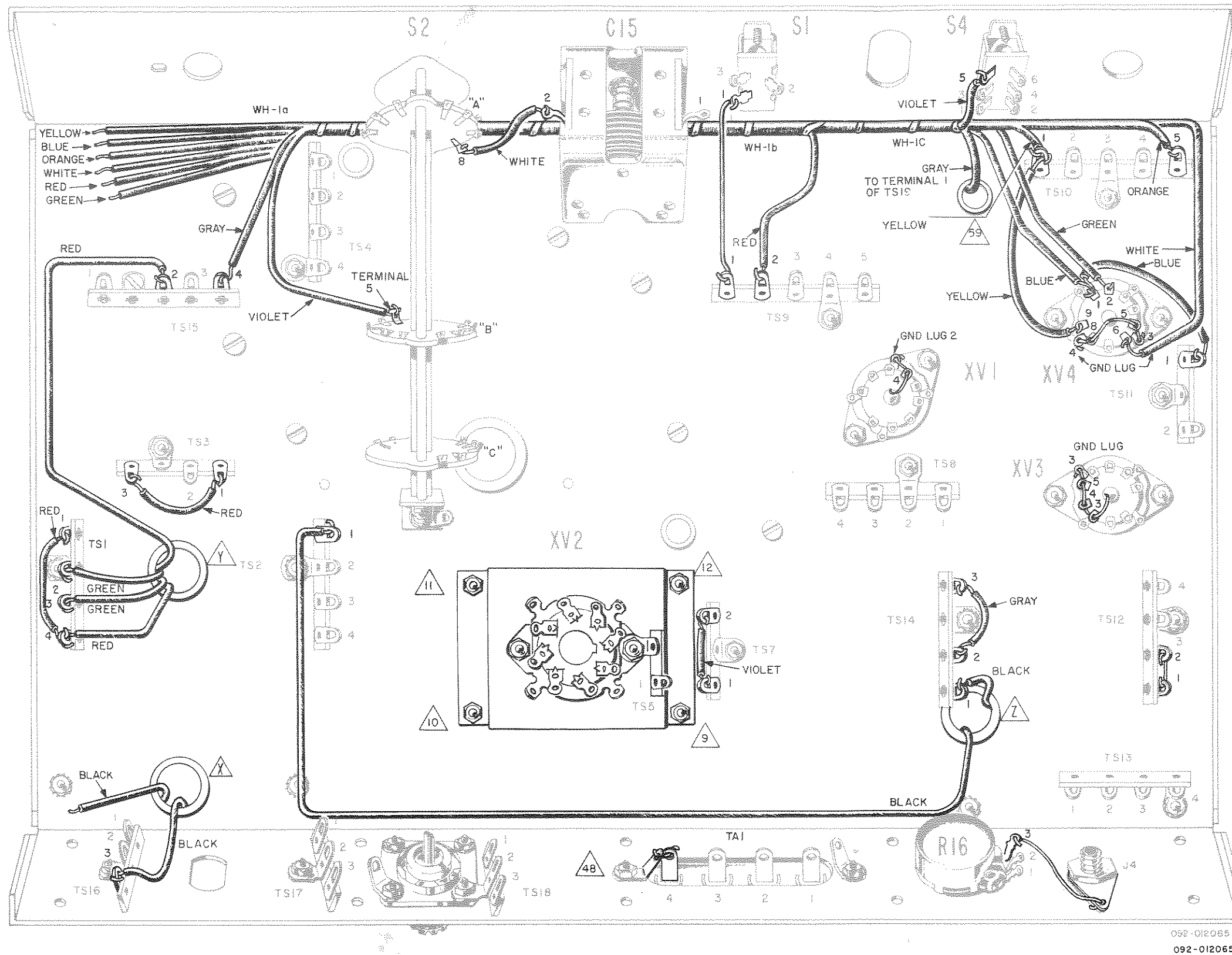

Figure 12. Wiring Tank Coil L10.

092-010207B



Pictorial 3. Connecting Wiring Harness WH-1.

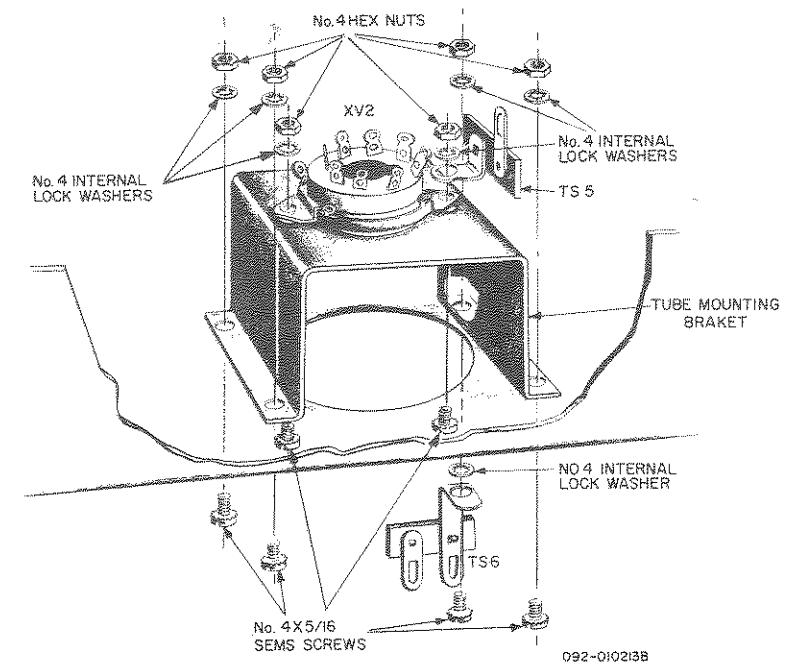

Figure 8. Mounting XV2 and Bracket.

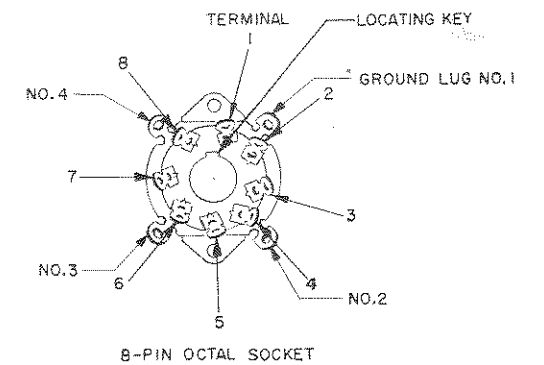
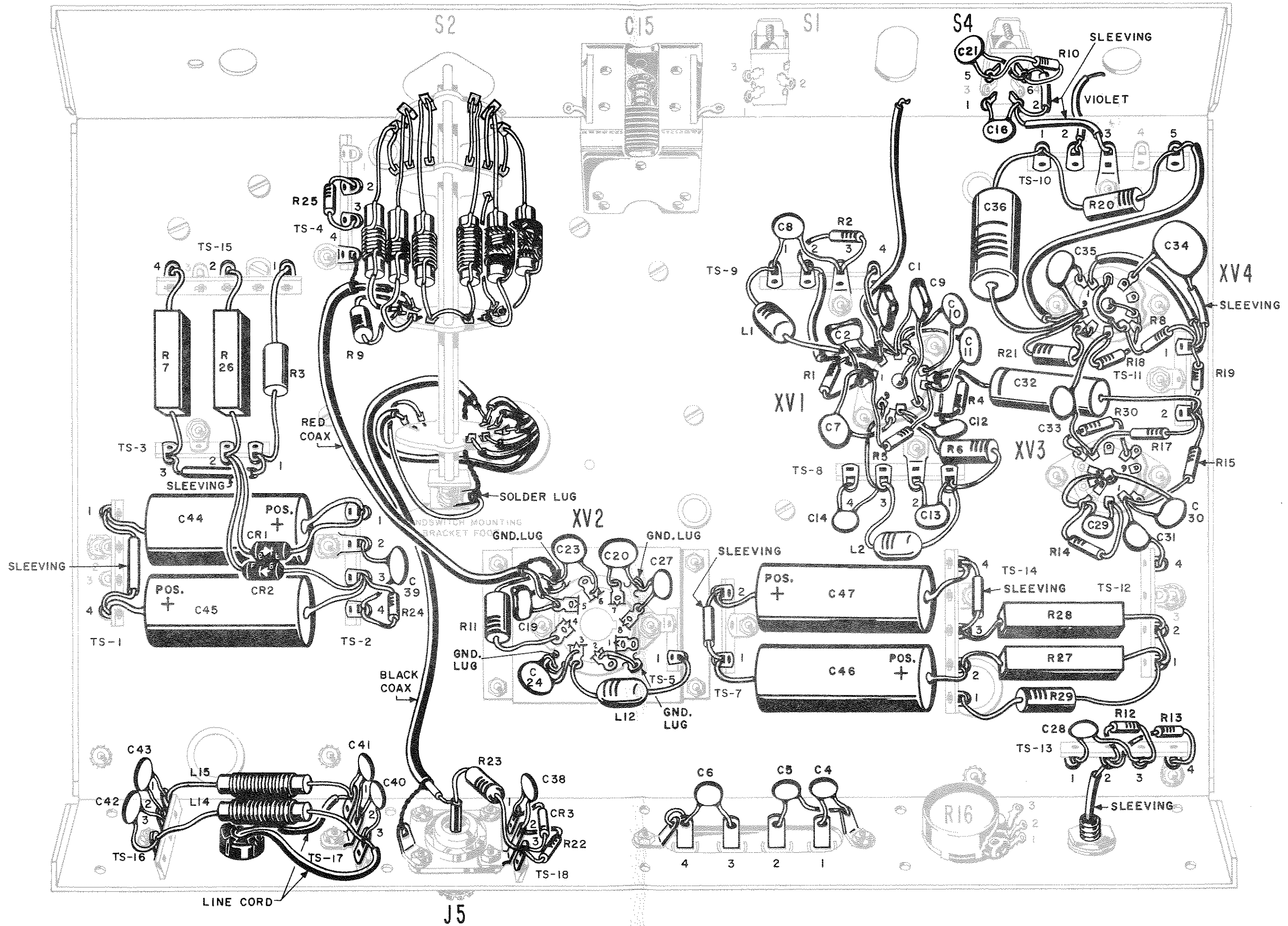
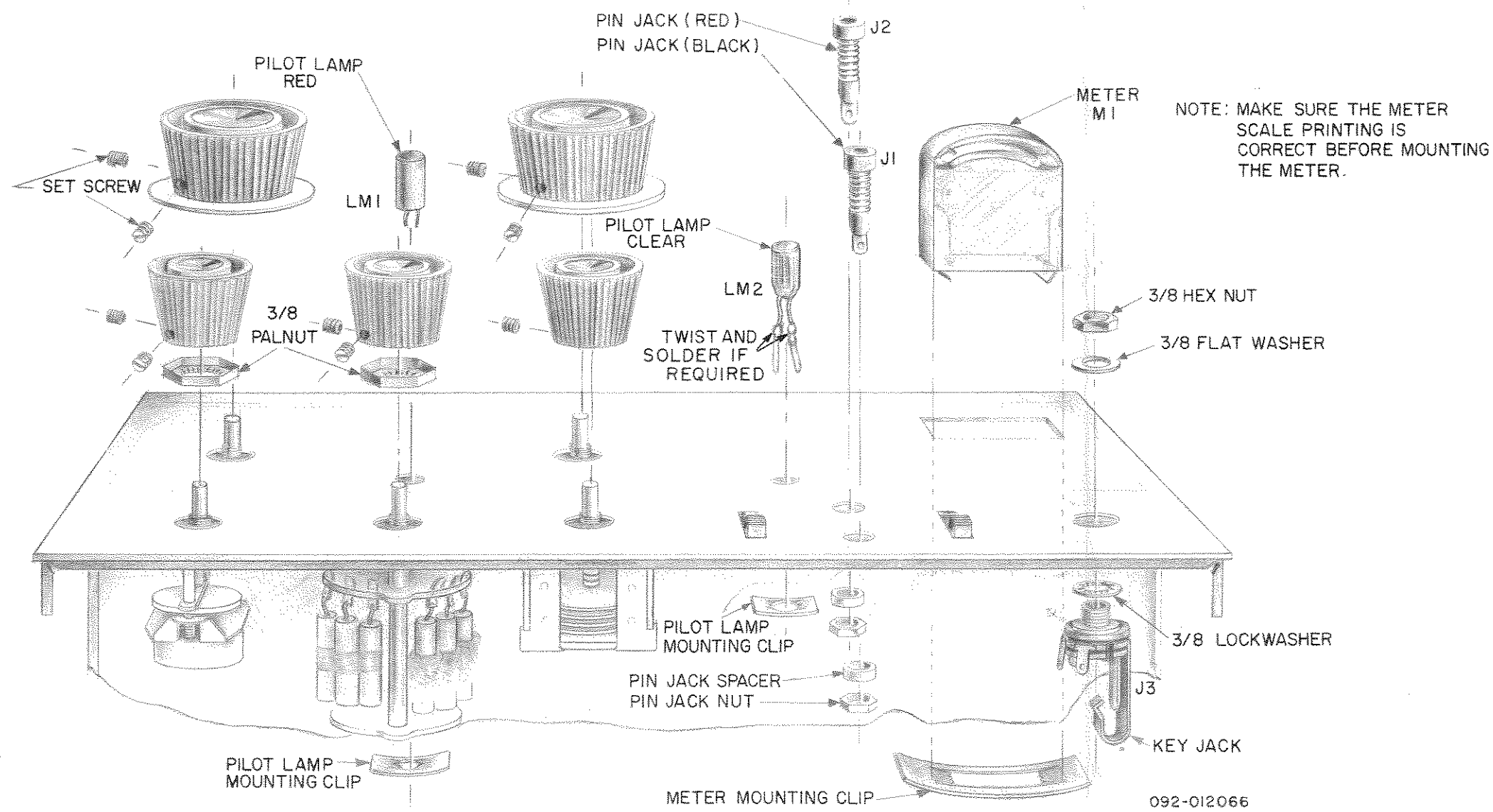

Figure 9. 8-Pin Octal Socket.



Pictorial 6. Wiring of Components.



Pictorial 6. Exploded View of Panel Controls.

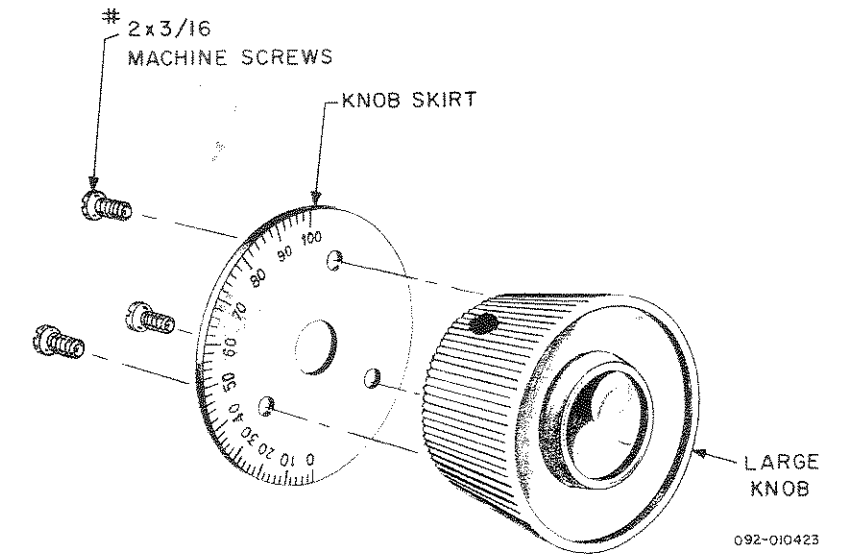

Figure 18. Knob Mounting Detail.

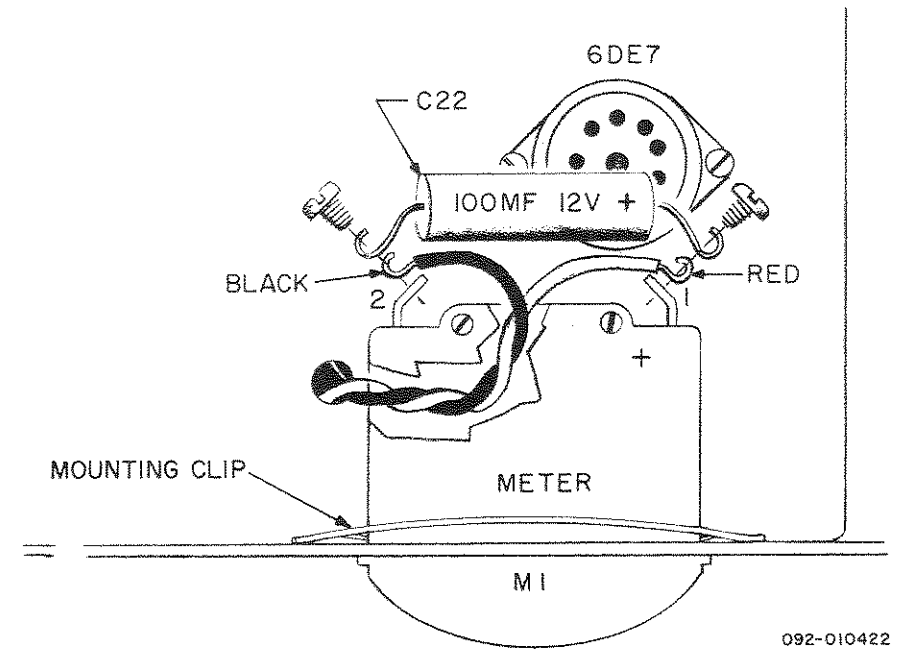
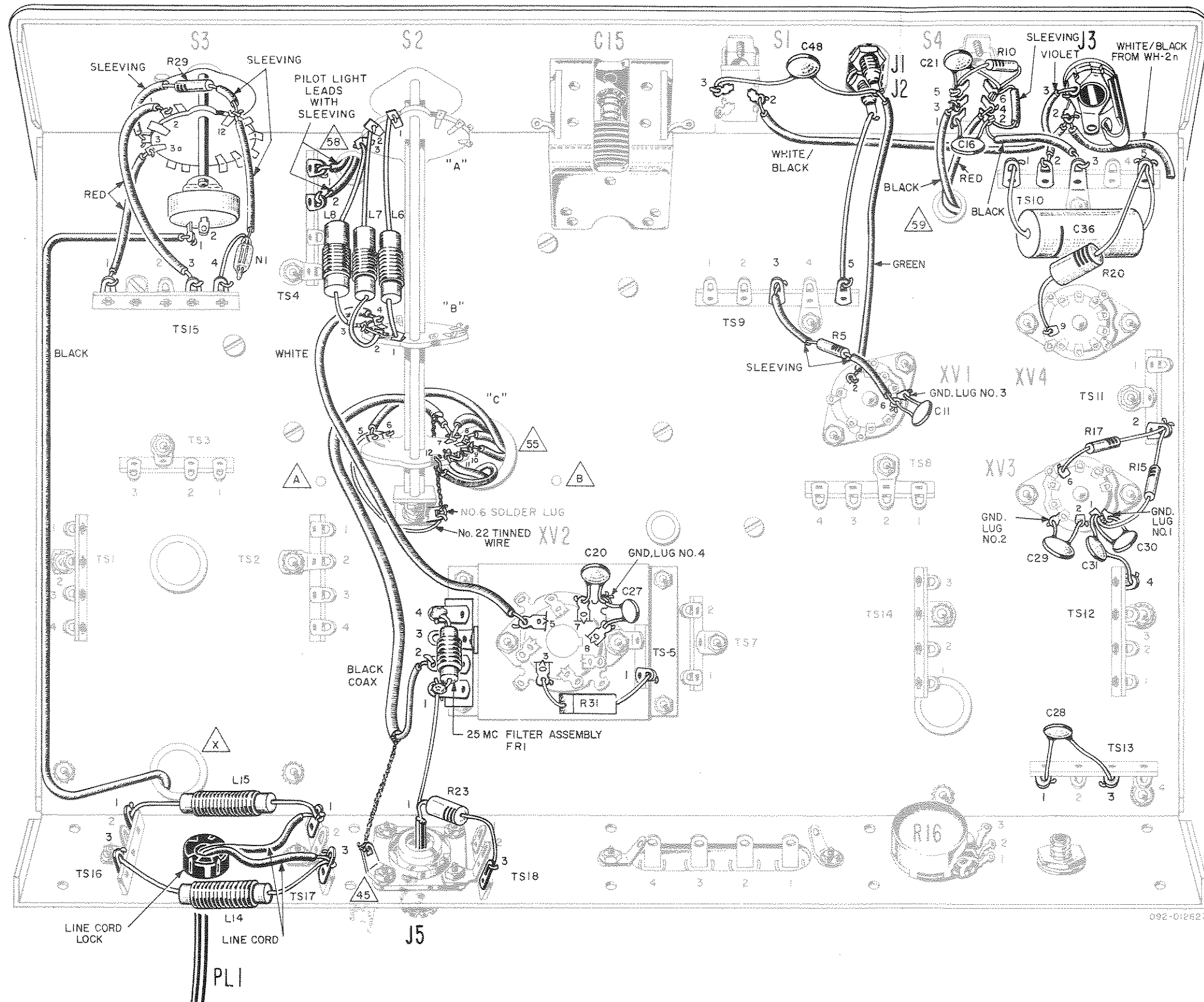

Figure 13. Wiring to Meter M1.



Pictorial 7. Final Component Wiring on Bottom of Chassis.

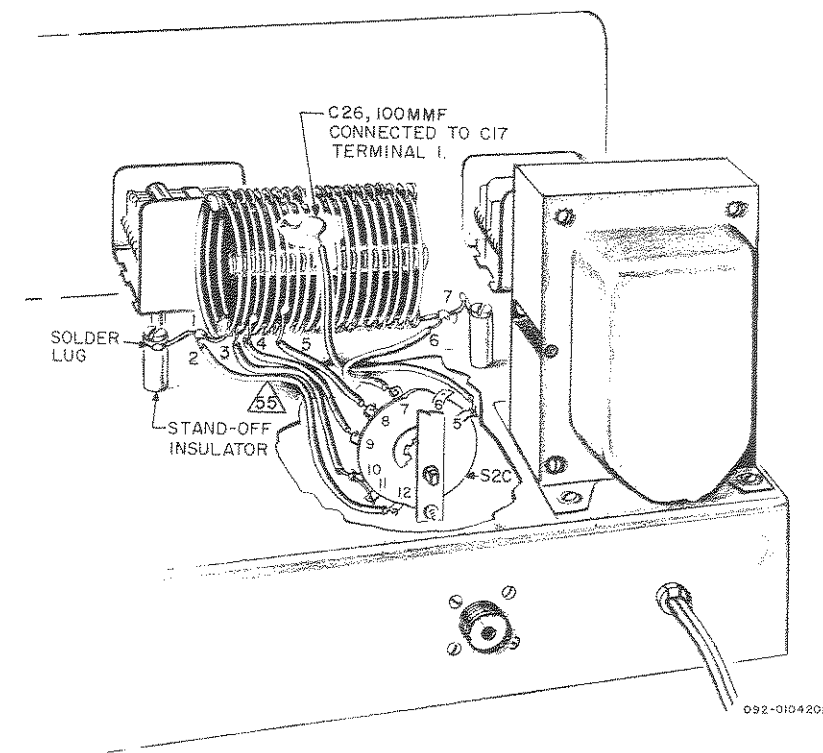

Figure 14. Wiring Between L10 and S2C.

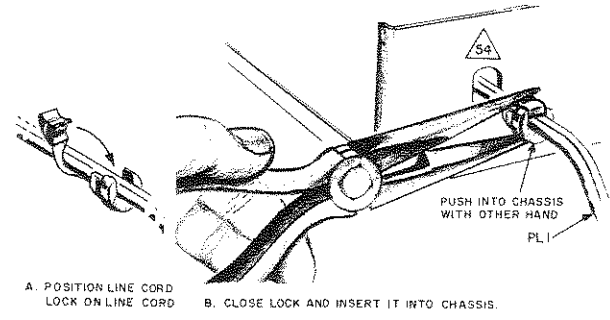

Figure 15. Mounting Line Cord and Lock.

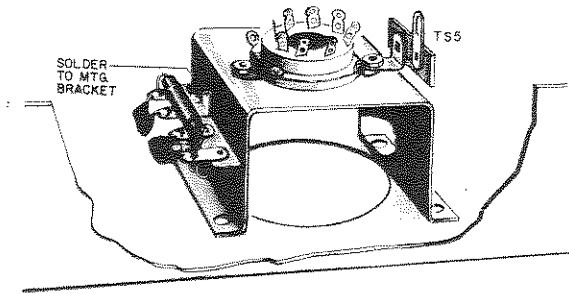

Figure 16. Mounting FR1.

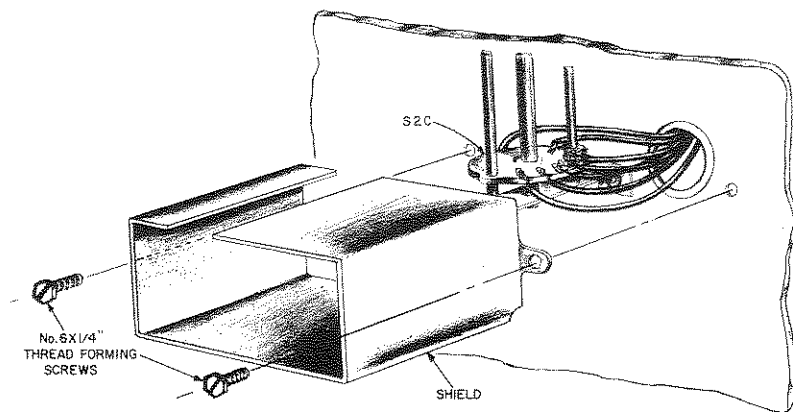
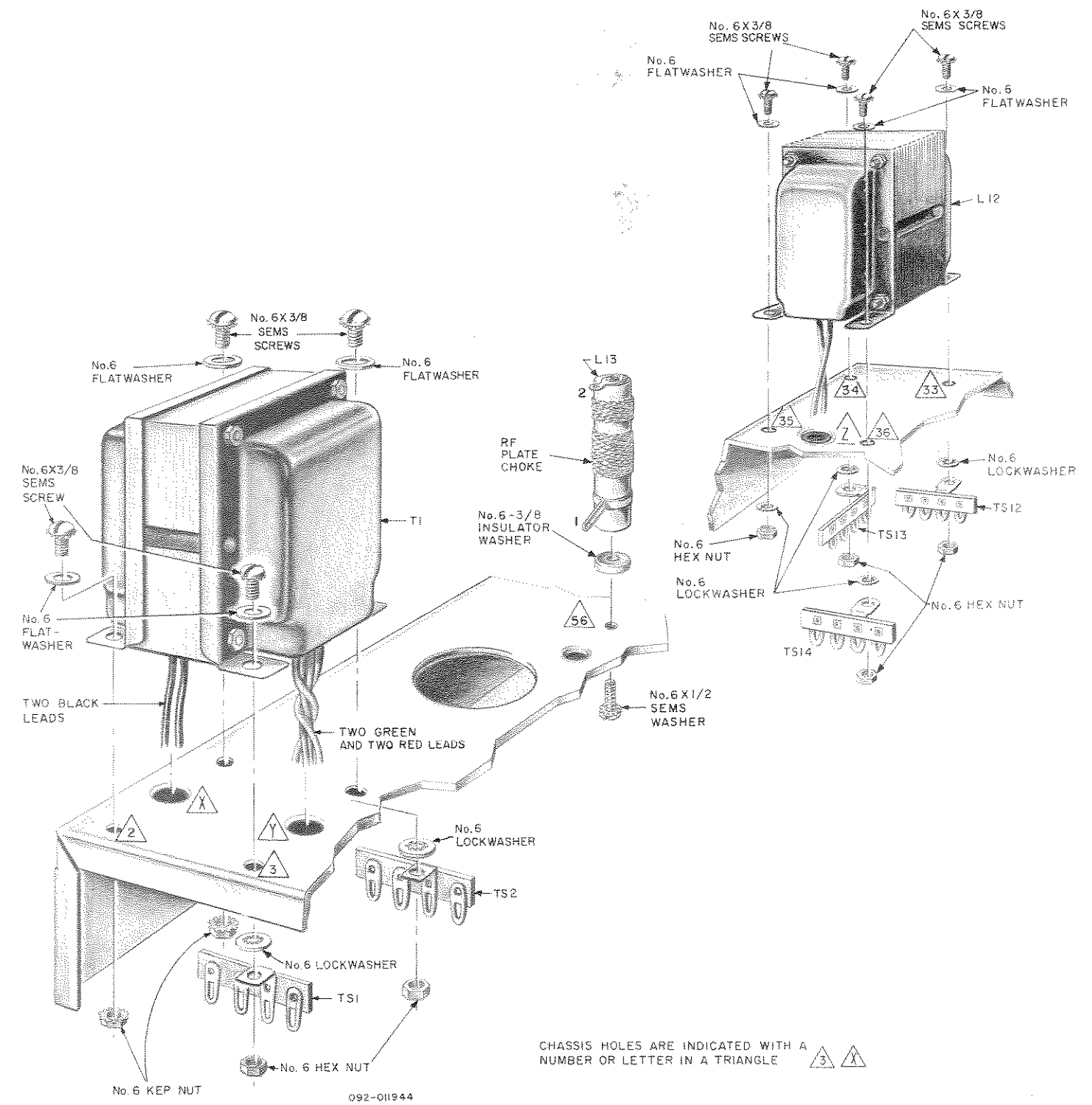

Figure 17. Mounting Shield on S2C.



Pictorial 1. Mounting the Transformers.