

**INSTRUCTION MANUAL**  
**FOR**  
**MODEL NRD-92/NRD-93 RECEIVER**



*Japan Radio Co., Ltd.*



MODEL NRD-92 RECEIVER  
OUTSIDE VIEW (DESK-MOUNT TYPE)



MODEL NRD-92 RECEIVER  
OUTSIDE VIEW (CONSOLE OR RACK TYPE)

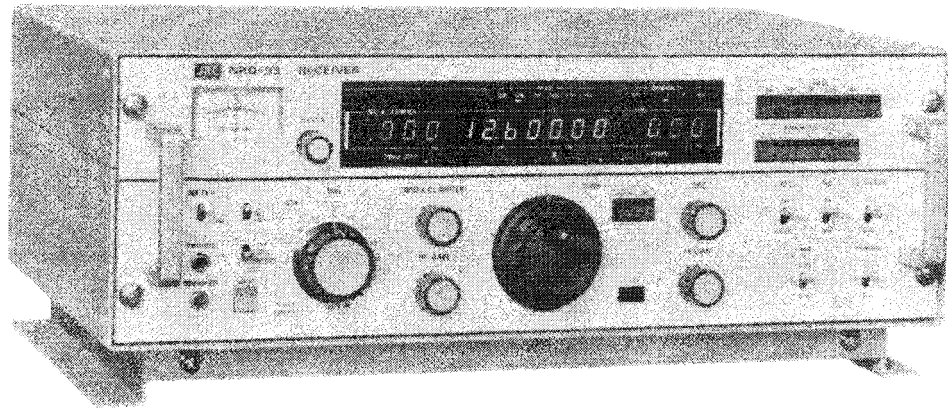

MODEL NRD-93 RECEIVER  
OUTSIDE VIEW (DESK-MOUNT TYPE)

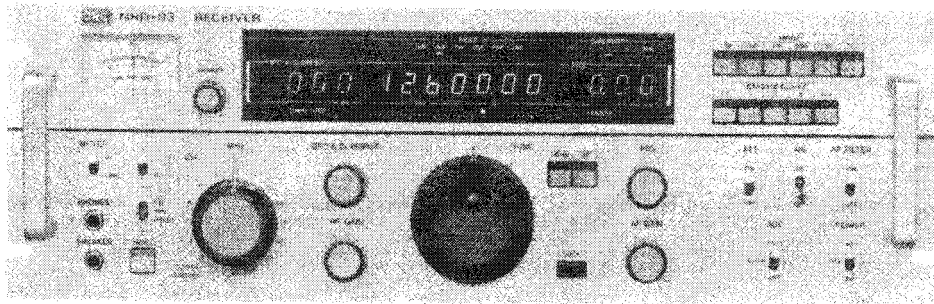

MODEL NRD-93 RECEIVER  
OUTSIDE VIEW (CONSOLE OR RACK TYPE)

# CONTENTS

	Page
CAUTION .....	1
<b>1. GENERAL DESCRIPTION .....</b>	<b>2</b>
1.1 Features .....	2
1.2 Specifications .....	2
<b>2. COMPOSITION .....</b>	<b>6</b>
2.1 Standard Composition .....	6
2.2 Option .....	6
<b>3. INSTALLATION .....</b>	<b>7</b>
3.1 Installation .....	7
3.2 Anti-induction of the Transmitting Wave .....	7
3.3 Connection of External Lines .....	7
<b>4. OPERATION .....</b>	<b>11</b>
4.1 Operation Panel of NRD-92 .....	11
4.2 Operation Panel of NRD-93 .....	13
4.3 Operating Procedure .....	14
4.3.1 Basic operation of SSB reception .....	14
4.3.2 Basic operation of CW reception (Morse telegraph) .....	14
4.3.3 Operation of DSB reception .....	15
4.3.4 Operation of FSK reception .....	15
4.3.5 Operation of FAX reception .....	15
4.3.6 Further operation .....	16
<b>5. CIRCUIT DESCRIPTION .....</b>	<b>19</b>
5.1 Receiving Section .....	19
5.2 Synthesizer Section .....	21
5.3 Control Section .....	23
5.4 Power Supply Section .....	24
<b>6. MAINTENANCE AND CHECK .....</b>	<b>25</b>
6.1 General Description .....	25
6.2 General Maintenance and Check .....	25
6.3 Troubleshooting .....	26
6.3.1 Decline of the sensitivity .....	26
6.3.2 No sound .....	27
6.3.3 Noise and beat .....	27
6.3.4 Interference by the transmitter of own station .....	28

6.3.5	Intermodulation .....	29
-------	-----------------------	----

### **Appended Drawings**

- Parts Arrangements
- Block Diagram
- Outline Drawing
- Circuit Diagram
- Speaker Unit

## CAUTION

1. Read this instruction manual thoroughly before turning on this receiver.
2. This receiver employs a little different indicating method of frequency, BFO & CLARIFIER and PBS (Passband-shift) etc., from those of existing receivers.  
If you have any questions while operating this receiver, please read Chapter 4, "OPERATION", again.
3. When connecting the BK cable and other cables, refer to Fig. 3-3 on page 9.
4. When the transmitting waves are strongly induced in the receiving antenna, take the countermeasure described in Paragraph 3.2 on page 7.
5. Do not turn screws locked with the green adhesive, and semifixed resistors and trimmer capacitors mounted on the printed circuit board unless absolutely necessary, because they are all preadjusted at the factory.
6. If the MHz knob is set at inadequate position, the receiver will operate erroneously. Therefore, the MHz knob must be set correctly.
7. This receiver has low-voltage-operatable ICs and transistors. Be sure to turn off both power switches when connecting or removing the printed circuit board and cables to external equipments.

# 1. GENERAL DESCRIPTION

The Model NRD-92/93 Receivers have been designed based on our many year's experiment and technical results, and manufactured under the strict quality control. These receivers have the 10Hz step digital synthesizer and 1Hz step BFO synthesizer which provide a high frequency stability and high accuracy of frequency setting. Therefore these NRD-92/93 are the most suitable for high quality communication such as narrow band direct printing, digital selective calling, Lincompex, etc. Since the double-tuning circuit, composed of our developed high-performance capacitor diode, is employed at the input part, the high sensitivity can be obtained even in the crowded communicating band. Besides the above functions, the receiver is provided with many functions such as the noise blanker, AF filter, pass band shift (PBS) (NRD-93), etc., so that NRD-92/93 can secure the important communication even under the bad condition.

## 1.1 Features

- (1) Fine step synthesizer  
10Hz step synthesizer is employed in the first local oscillator and 1Hz step frequency synthesizer in BFO circuit. These synthesizers ensure a high frequency stability and enable the smooth fine adjustment.
- (2) Tunable input filters  
Automatic tuning circuit, located at the input circuit, selects only desired frequency and signal near that frequency, so that the effective sensitivity becomes very high.
- (3) Atmospherics eliminating function  
The receiver is equipped with the noise blanker which cuts the pulse noise due to rain, snow, etc. and AF filter which improves S/N of the signal with a large amount of noise.
- (4) Anti-interference (only NRD-93)  
The interference signals around the desired frequency can be cut by PBS. (pass band shift).
- (5) Built-in preset channels (only NRD-93)  
The frequencies, reception modes and bandwidths of 60 channels can be stored in the memory, and can be read out from the memory at any time.
- (6) Entirely modular construction  
The circuits are accommodated in plug-in type printed circuit boards, thus forming a fully modular construction facilitating easy maintenance and checks.

## 1.2 Specifications

- (1) Receiving frequency range  
90KHz to 29.99999MHz
- (2) Receiving system  
Double superheterodyne with the up-conversion system using a phase-locked digital frequency synthesizer  
1st IF: 70.455MHz  
2nd IF: 455kHz
- (3) Reception mode  
CW (A1A), MCW (A2A, H2A), DSB (A3E), SSB (R3E, H3E, J3E), FSK (F1B) and FAX (F3C)  
The model NRD-93 is capable of selecting USB and LSB.

(4) Receiving frequency indication

Light emitting diode for seven-digit numerical display (10MHz- to 10Hz- digit)  
The mode NRD-93 is equipped with 20KHz step analogue display.

(5) Tuning method

- a) Tuning with MHz-band setting knob, UP/DOWN switch and 10KHz/rotation TUNE knob.  
Automatic carry and borrow function in MHz band display is provided.
- b) By MHz setting knob, preset channels of 2182KHz and 500KHz can be selected.
- c) Selection of 60 preset channels by setting MHz/CH knob to CH (NRD-93)

(6) Sensitivity

Mode \ Frequency	CW	DSB	SSB	
90kHz – 200kHz	20 $\mu$ V or less	60 $\mu$ V or less	–	Bandwidth 3kHz Output 100mW
0.2 – 1.6MHz	10 $\mu$ V or less	30 $\mu$ V or less	–	
1.6 – 29.99999MHz	2 $\mu$ V or less	6 $\mu$ V or less	3 $\mu$ V or less	

CW : (S + N)/N = 20dB,

DSB : (S + N)/N = 20dB 1kHz 30%,

SSB : (S + N + D)/(N + D) = 20dB

(7) Selectivity

Model	Attenuation	6dB bandwidth	60dB bandwidth
	Notch		
NRD-93	6kHz	4.5 – 6.5kHz	14kHz or less
	3kHz	2.4 – 3kHz	4.1kHz or less
	1kHz	1 – 1.5kHz	3.0kHz or less
	0.3kHz	0.24 – 0.4kHz	0.56kHz or less
NRD-92	6kHz	4.5 – 7kHz	14kHz or less
	3kHz	2.4 – 8kHz	4.1kHz or less
	0.5kHz	0.5 – 0.8kHz	1.6kHz or less

(8) Frequency stability

Condition \ Model	NRD-92	NRD-93
15 minutes after 20-minute pre-heating	Within $\pm 5$ Hz	Within $\pm 2$ Hz
1 hour after 20-minute pre-heating	$\pm 1 \times 10^{-6}$ or less	$\pm 5 \times 10^{-7}$ or less

(9) Image rejection ratio

NRD-92 : 60dB or more

NRD-93 : 70dB or more



- (10) IF rejection ratio  
 NRD-92 : 70dB or more  
 NRD-93 : 80dB or more
- (11) Spurious response  
 NRD-92 : 60dB or more  
 NRD-93 : 70dB or more
- (12) Blocking  
 The input level of the unwanted signal shall be more than 10mV which suppress the output level of the wanted signal by 3dB, under a condition where the unwanted signal is separated by 3kHz or more from the wanted signal of 10μV.  
 (SSB/USB mode, 3kHz, AGC ON)
- (13) Overall distortion  
 The ratio of 1000Hz output to its unwanted frequency component is 30dB or more under a condition where an output of 100mW is set by an input voltage of 30μV (SSB/USB mode, AGC ON, AF filter OFF)
- (14) Overall frequency response  
 The output deviation is 6dB or less for modulation frequency between 350Hz to 2700Hz.  
 (Mode SSB/USB, AF filter OFF, AGC OFF)
- (15) Group delay  
 3mS or less for modulation frequency between 350Hz to 2700Hz  
 (Mode SSB/USB, 3kHz, AF filter OFF)
- (16) AGC characteristic  
 The variation of the AF output is 10dB or less when varying the level of the input signal within the range from 3μV to 100mV.  
 (Mode SSB/USB, 3kHz, AGC S, Receiving frequency is higher than 400kHz)
- (17) Radiation  
 The power radiated to the antenna terminal is less than  $1 \times 10^{-9}W$
- (18) Nominal input impedance  
 50 – 75 ohms unbalanced
- (19) IF output  
 0.05Vrms or more at the input voltage of 3μV
- (20) Variable range of BFO and clarifier  
 BFO : ±2kHz 10Hz step (CW mode)  
 Clarifier : ±120Hz 1Hz step (modes except CW and DSB)  
 10Hz step (DSB mode)  
 BFO is set to 0.8kHz and clarifier to 0kHz at the initial setting
- (21) Variable range of P.B.S. (NRD-93)

Bandwidth	0.3kHz	1kHz	3kHz	6kHz	AUX
Variable range	±0.12kHz	±0.5kHz	±1.2kHz	±2.0kHz	±0.08kHz
	10Hz step				

(22) AF filter

Item \ Mode	CW mode	Modes other than CW mode
Nominal center freq.	750Hz	800Hz
20dB pass band	Approx. 100 – 2400Hz	Approx. 100 – 5000Hz

(23) AF characteristics

Item \ Output	Rated impedance	Nominal output level	6dB bandwidth
Speaker output	600Ω unbalanced	1W or more (5%)	300Hz – 6000Hz
Speaker output	4Ω unbalanced	1W or more (5%)	300Hz – 6000Hz
Headphone output	600Ω unbalanced	10mW or more	300Hz – 6000Hz
Line output	600Ω balanced	1mW or more	300Hz – 6000Hz

(24) RF attenuator

Approx. 20dB

(25) Power supply

AC power supply

100/110/115/220/230V ±10%

Single phase 50/60Hz

Power consumption is approx. 70VA

DC power supply

24V ±10% (negative grounded) approx. 50W

(26) Temperature range and relative humidity

-10°C to +50°C, less than 95% at +35°C

(27) Dimensions and weight

Without the cabinet case

149(H) × 480(W) × 294(D) excluding protuberance approx. 10.5kg

With the cabinet case

190(H) × 489(W) × 305(D) excluding protuberance approx. 15kg

## 2. COMPOSITION

The composition of this receiver depends on its type; it is available as a deskmount type, rack type or console type.

### 2.1 Standard Composition

Item	Model or code	Q'ty	Remarks
Receiver	NRD-92/NRD-93	1	
Cabinet case	MPBX10832	1	Provided for only the deskmount type
Speaker	NVA-92	1	600 ohms 1W
Power cable	6ZCJD00005	1	Approx. 2m
BK cable	MPKC03108	1	
Instruction manual		1	English
ANT connector	M-P-7	1	The receiver is shipped, equipped with this ANT connector
Spare parts	6ZXJD51039	1 set	*
Test data		1	

\* Spare parts include: Each of all types of fixed resistors, fixed capacitors and variable resistors, BK relay, and fuses (same number as those actually used)

### 2.2 Option

Item	Model or code	Usage or general
Scanning unit	NDH-93 W x H x D = 480 x 49 x 86 (without the cabinet)	Capable of performing pre-set reception, auto scanning reception and auto sweep reception. Capable of storing receiving frequencies, IF bandwidths and reception modes of 300 channels in the memory.
Cabinet case for scanning unit	MPBX 10828	W x H x D = 489 x 58 x 305
Headphone	ST-3	600 ohms
DC power cable	MPKC01741	
AUX filter	YF 455FM YF 455DE YF 455CB	Width 0.3kHz 1.0kHz 0.2kHz There is an installation space for one filter on the filter PC board of the receiver
Extention card for maintenance	CMH-330	Used for checking each PC board in operation.

### 3. INSTALLATION

#### 3.1 Installation

- (1) When installing this receiver on the 19-inch standard rack, place the guide bolt provided on the side of the chassis on the rail, and push the receiver inside the rack. Then, fix the receiver in position by screwing the 5-mm screws through the 4 mounting holes at the right and left of the front panel.
- (2) When installing the receiver on the desk, use the special cabinet (optionally available on separate order).  
Attach the slide rails (supplied with the cabinet case) onto left and right sides of chassis of the receiver and mount the receiver in the cabinet case. Fix the receiver to the cabinet case by screwing the 5-mm screws through four mounting holes on the front panel.

#### 3.2 Anti-induction of the Transmitting Wave

When the receiver is operated with a paired transmitter, it sometimes happens that the transmitting wave of own station is induced in the receiving antenna.

When the induction current of the transmitting waves is 1 ampere or less, the receiver is protected by the built-in input protective circuit. But if the induction current exceeds 1 ampere, it sometimes happens that the input circuit of the receiver is burnt out.

When the receiving antenna suffers from such an excessive induction current, move the receiving antenna as far as possible from the transmitting antenna, or insert the anti-inducer in series between the receiving antenna and antenna input connector as shown in Fig. 3-1.

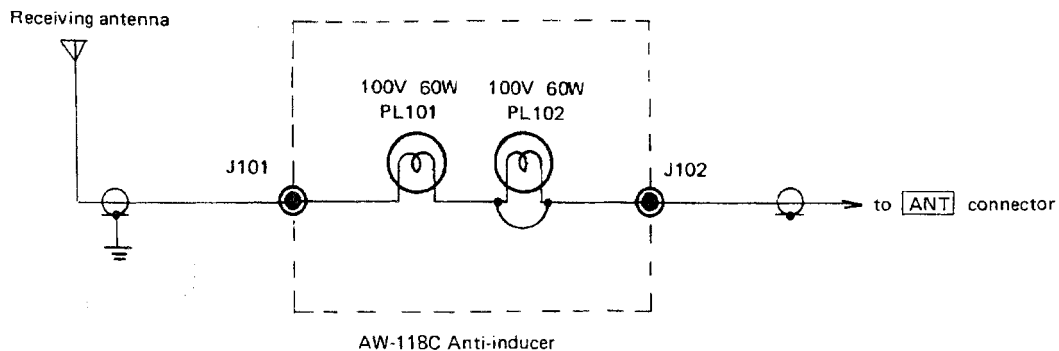

Fig. 3-1 Protection of the Receiver by the Anti-inducer

#### 3.3 Connection of External Lines

- (1) This receiver operates in DC24V  $\pm 10\%$  in case of the DC power operation.  
When JRC were informed about the working voltage, beforehand, the working voltage of AC power was adjusted to one among AC100/110/115/220/230V according to the customer's specification, and the label, on which the specified voltage is noted, is attached to the power input connector on the rear panel.  
When changing the power voltage at the installation place, change the terminal connection of the power transformer located inside the chassis as shown in Fig. 3-2.

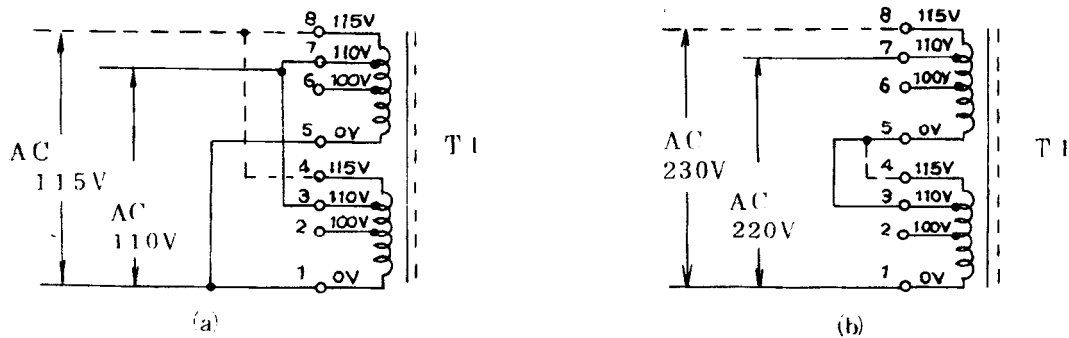

Fig. 3-2 Connection of the Power Transformer

For DC power operation, connect the power cable to **DC24V** connector located on the rear panel of the main frame.

For matching the polarity to that of the power supply, the wire (black) connected to pin 2 of the input connector is negative electrode and the wire (white) connected to pin 1 is positive electrode.

- (2) Connect the antenna cable to the **ANT** connector provided at the rear panel.
- (3) Connect the grounded wire to the terminal **E** on the rear panel.
- (4) Connect the **IF OUT** connector and the input connector of the external component by using the coaxial cable, when the IF output is to be used.
- (5) If the break-in relay circuit is to be used, connect the special cable (MPKC03108 or cable supplied with the console) to the **BK & LINE** connector. The AF output signal (600Ω/4Ω unbalanced speaker output, and 600Ω balanced line output) can be taken out from this connector. See Fig. 3-3 for details.
- (6) When the scanning unit (NDH-93, special order) is to be used, connect the cable supplied with the scanning unit to the **PRESET** connector.
- (7) When the external highly stable crystal oscillator is to be used, supply the output of the oscillator (10MHz, TTL level) to the **EXT 10MHz** connector and set the selector switch, S1, located on the rear panel to the **EXT** side (only NRD-93). Usually, since the built-in crystal oscillator is used, set this switch to the **INT** side.

**NOTE:** Note that the sound never comes out from the receiver, if this switch is set to the **EXT** side erroneously when the external 10MHz output is not to be used.

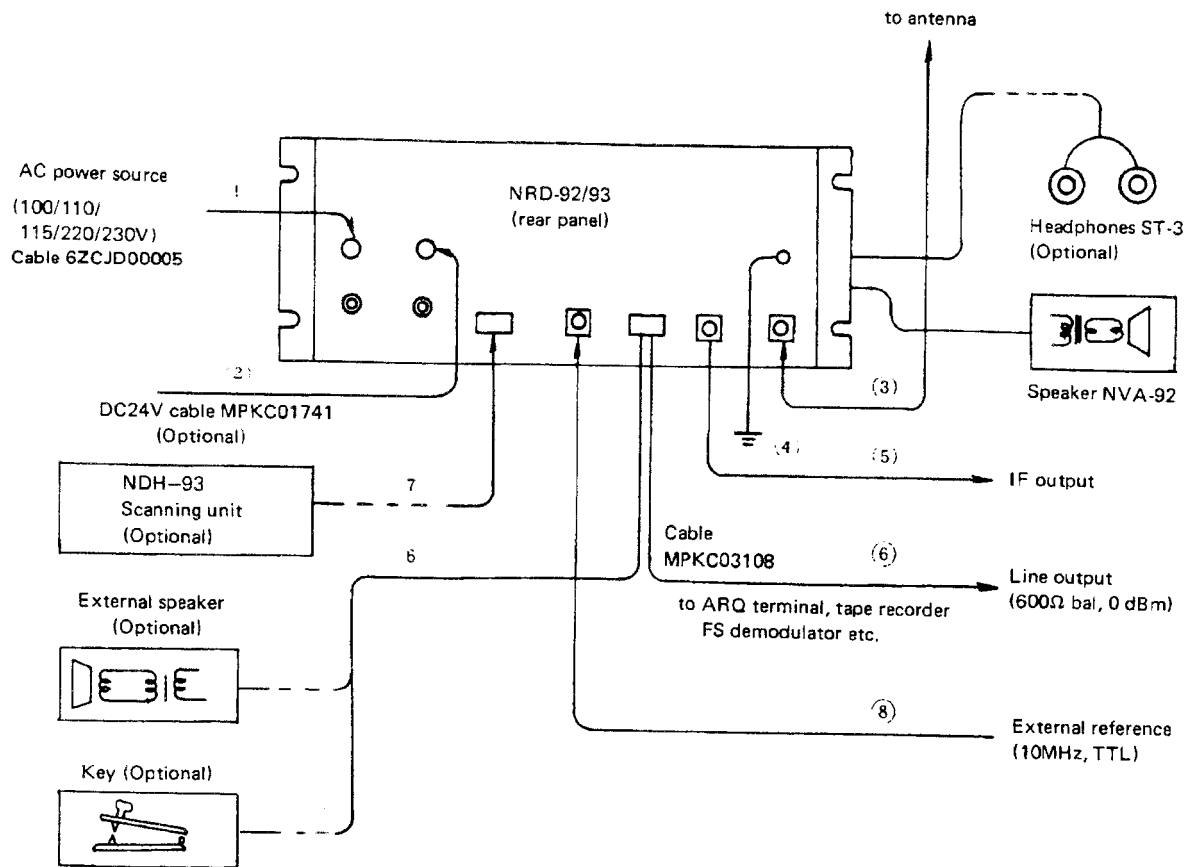

Fig. 3-3 External Connection

Item	Indication	Cable and cable side connector	Pin	Color	Explanation
1	AC100V220V 110V230V 115V	Connector HS16P-2 Cable 6ZCJD00005	1 2	White Black	AC power input The cable is attached with the receiver, only when receiver is mounted in the cabinet and shipped.
2	DC24V	Connector HS12P-2 Cable MPKC0174	1 2	White Black	+ side - side (grounded) (Cable is optional.)
3	ANT	M-P-3/5/7	-	-	Antenna input
4	E	MPTE0006	-	-	Grounded
5	IF OUT	3CV-P2	-	-	IF output
6	BK & LINE	Connector S-1312-CEA Cable MPKC03108  Note When the receiver is halfly muted or 4Ω speaker is connected, remove the green wire of pin 10 at the connector side of the cable and solder it to pin 6 or pin 12 of the cable connector.	1 2 3 4 5 6 7 8 9 10 11 12	White Red Black Green Silver - White Red Black Green Silver -	-BK (key signal) +BK (BK power +24V) E } 600Ω unbalanced SP } 1W output Shielded (common ground) For half muting (for JSB-550) Line } 600Ω Line } balanced, 0dBm, Center tap } AF output No use Shielded (common ground) No use (4Ω unbalanced, 1W output)
7	PRESET	Connector P-1308-CEA	-	-	Connector and cable are supplied with the optional units.
8	EXT 10MHz	3CV-P2	-	-	External 10MHz input (supplied only with NRD-93)

## 4. OPERATION

### 4.1 Operation Panel of NRD-92

Switches and controls shown in Fig. 4-1 are provided on the front panel.

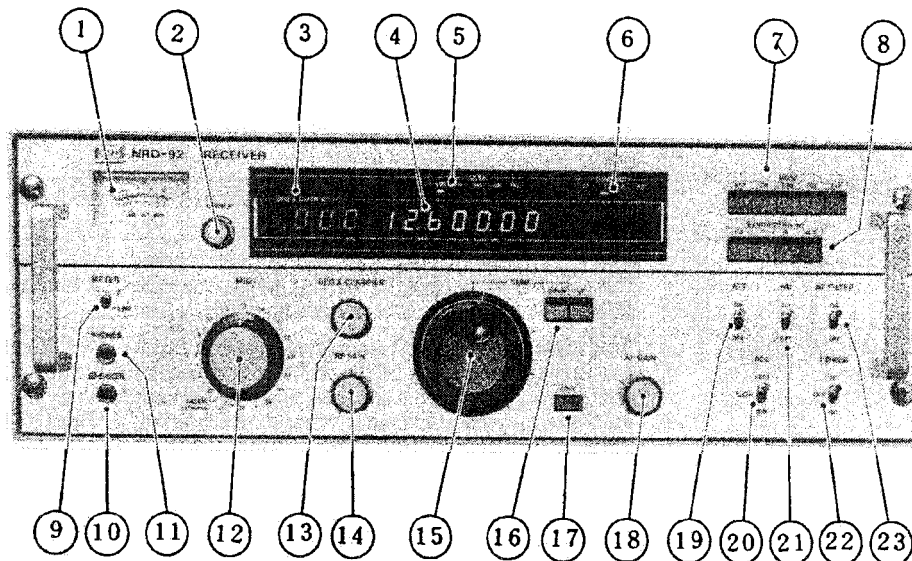

Fig. 4-1 Panel of NRD-92

No.	Control	Function
1	Meter	Indicating the strength of the receiving waves or level of the AF output (line output terminal)
2	DIMMER knob	Used for adjusting the brightness of all LEDs. Adjust the brightness by this knob according to the circumstance. It is advisable to set this knob to the position as near as possible to the minimum position with having sufficient brightness, for the less power consumption and longer lifetime of this equipment.
3	BFO & CLARIFIER	In case of CW mode (Morse telegraph), the deviated frequency of FBO from nominal frequency of 455kHz is displayed. In case of modes other than CW, the deviated frequency by CLARIFIER control from nominal receiving frequency is displayed. When the preset channel is read out from the external optional unit, BFO is initialized to 800Hz and CLARIFIER is initialized to 0Hz.
4	Receiving frequency	Displaying the receiving frequency by 7-digit numerical numbers. In case of SSB mode, the carrier frequency is displayed and in case of modes other than that, the assigned frequency is displayed.
5	MODE indicator	Displaying the reception mode specified by the MODE (7) switch or external optional unit.
6	BANDWIDTH indicator	Displaying the bandwidth of the IF filter specified by the BANDWIDTH selector switch (8) or the external optional unit. When the SSB mode is specified, 3kHz is automatically selected.



No.	Control	Function
7	MODE selector switch	Used for selecting the reception mode. When selecting SSB mode, the 3kHz band is automatically selected. In case of SSB mode, the frequency indicator ④ displays the carrier frequency and in case of modes other than this mode, it displays an assigned frequency. When the CW mode is selected, the BFO & CLARIFIER ③ serves as the BFO indicator. When selecting modes other than CW, it serves as the clarifier indicator.
8	BANDWIDTH selector switch	Selecting the bandwidth of the IF filter (intermediate frequency)
9	METER selector switch	Selecting the content to be indicated for the meter ①. When setting this switch to S, and turning RF GAIN ⑭ fully clockwise, setting the AGC switch ⑳ to [FAST] or [SLOW], the meter pointer indicates the relative signal strength of the HF input of the receiver. When setting this switch to [LINE], the meter indicates the AF output level of the line output terminal (600Ω balanced).
10	SPEAKER jack	Used for connecting the special speaker, NVA-92 or the speaker of 600Ω impedance.
11	PHONES jack	Used for connecting the optional headphone ST-3 or the headphone of 600Ω impedance.
12	MHz selector	Used for setting the MHz digit of the receiving frequency. When setting this selector to [2182kHz] or [500kHz], the receiving frequency, DSB mode and 6kHz filter are automatically selected.
13	BFO & CLARIFIER knob	This knob serves as BFO adjustment knob in case of the CW mode and can vary the frequency of the 455kHz beat oscillator up to ±2kHz in 10Hz steps. This knob also serves as an adjustment knob of the receiving frequency in modes other than CW (clarifier knob). The fine adjustment range covers ±120Hz around an indicated frequency, in 1Hz intervals. In either BFO or CLARIFIER, the amount of varied frequencies is displayed on BFO & CLARIFIER indicator ③. The knob itself turns endlessly. But variable range is limited to ±2kHz and ±120Hz for BFO and CLARIFIER respectively.
14	RF GAIN knob	This is a gain controller for the RF amplifier and IF amplifier. It is recommended to adjust according to the strength of the receiving frequency for obtaining the optimum volume.
15	TUNE knob	Used for setting the receiving frequency in 10Hz steps. The full rotation changes the receiving frequency by 10kHz.
16	UP/DOWN switch	Fast forward switch of the receiving frequency. While pressing [UP] (or [DOWN]), the frequency increases (or decreases) at a speed of approx. 125kHz/second.
17	LOCK switch	Used for locking the set frequency electrically so as not to be changed by careless misoperation. By setting this switch to the locked condition (pressed) the receiving frequency will not be changed even though operating the TUNE knob ⑬ and UP/DOWN switch ⑯. For releasing the locked condition, press this switch again.
18	AF GAIN knob	This is a volume adjustment knob for the speaker or headphone. And this knob does not effect the level of the line output (600Ω balanced) on the rear panel of the receiver.
19	Attenuator switch	Used for selecting the ON or OFF condition of the 20dB HF attenuator for the receiver input. Set this switch to ON for the better reception when the signal is received at the near distance and the desired signal is interfered due to the strong neighboring signals etc. But usually, set this switch to the OFF position.
20	AGC switch	Used for selecting the ON or OFF condition of the AGC circuit and selecting the discharging time constant. The [FAST] position is for the reception of DSB signals, and the [SLOW] position is normally for the reception of SSB signals. By setting this switch to OFF, the AGC circuit remains inoperative and signals are saturated. Thus, control the gain by the [RF GAIN] knob ⑭ for the best receiving condition.

No.	Control	Function
21	NB switch	When a large amount of pulse noise interfere the reception, set this switch to ON for optimum reception. But since it sometimes happen that the signal is distorted, this switch is usually set to the OFF position.
22	POWER switch	Used for turning ON or OFF the power. Also used for selecting AC or DC power supply.
23	AF FILTER switch	When receiving the noisy signal, set this switch to ON. S/N is improved and the sound becomes easier to hear. But normally, set this switch to OFF because the fidelity deteriorates a little.

#### 4.2 Operation Panel of NRD-93

The following controls are added besides controls of NRD-92.

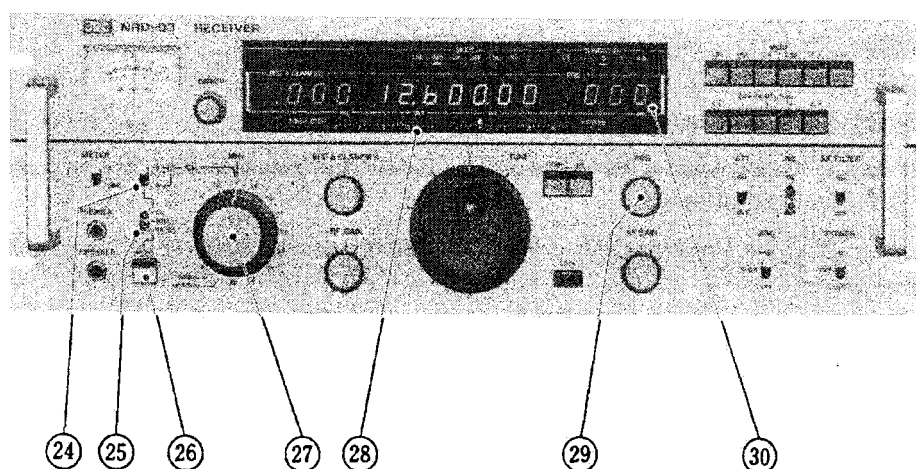

Fig. 4-2. Panel of NRD-93

No.	Control	Function
24	A/B group selector	Used for selecting the group of preset channels. 30 any desired frequencies can be programmed for each group of A and B.
25	CH/MHz selector	Used for selecting the function of MHz/CH knob ② . At the CH position, the 60 preset channels in total can be read out by operating the MHz/CH knob ② and A/B group selector ④ . At the MHz position, the MHz/CH knob ② works as the manual frequency setting control, and can specify the MHz-digit of the receiving frequency. At the [READY] position, frequencies of the built-in preset channels can be programmed and reloaded. For details, read the item (8) of 4.3.6.
26	MEMORY switch	Used for storing the frequency, bandwidth, and mode in the built-in preset channels. For details, read the item (8) of 4.3.6.
27	MHz/CH knob	Used for selecting the preset channel or specifying MHz-digit of the manual frequency setting.
28	Analogue dial	Indicating analogue frequencies (actually 20kHz step) less than MHz.
29	PBS knob	Used when the interference arises around the desired frequency. The knob turns endlessly, but the variation range is automatically limited according to the selected bandwidth. For details, read the item (4) of 4.3.6.
30	PBS indicator	Indicating how much extent the pass band is shifted. When operating the BANDWIDTH selector ⑧ , the displayed numerical number is cleared to 0. The variation range is limited according to the bandwidth. For details, read the item (4) of 4.3.6.

### 4.3 Operating Procedure

Before turning on the power switch, check the following items.

- (1) Power voltage check  
The label, which shows the nominal power voltage, is placed above the power connector located on the rear panel of the receiver. Check that the power voltage to be used is within the range of the nominal value  $\pm 10\%$ .
- (2) Antenna system check  
Check that each connecting part of the antenna cable to be connected to this receiver is firmly connected. When the antenna coupler and antenna changer are used, also check that they are correctly set.
- (3) Check of the connectors on the rear panel  
Check that each connector and grounded wire on the rear panel of the receiver are surely connected.
- (4) Connect the speaker or headphone to SPEAKER or PHONES jack.

#### 4.3.1 Basic operation of SSB reception

- (1) Set the **AF GAIN** knob to the position where the knob is turned clockwise by 2 or 3 graduations from the minimum position.
- (2) Set the **POWER** switch to **AC** in case of the AC power supply, or to **DC** in case of the DC power supply.
- (3) Press the **SSB** button among the **MODE** switches. (In case of NRD-93, press **USB**. Especially, only when receiving the radio wave of the LSB mode, press **LSB**.)
- (4) Set the desired receiving frequency by using the **MHz** knob, **UP/DOWN** switch and **TUNE** knob.
- (5) Set the **RF GAIN** knob to the maximum position and turn the AGC switch to **SLOW**.
- (6) After hearing the desired signal, turn the **AF GAIN** knob and set it for an optimum sound volume.
- (7) Adjust the **BFO & CLARIFIER** knob so as to set the tone the most natural to hear.
- (8) When the received radio wave is not strongly affected by fading, turn the **RF GAIN** knob slightly counterclockwise and **AF GAIN** knob slightly clockwise so as to obtain the best S/N of the reception voice.

#### 4.3.2 Basic operation of CW reception (Morse telegraph)

- (1) Set the **AF GAIN** knob to 2 or 3 graduations.
- (2) Press the **CW** button among the **MODE** switches. When setting the mode to **CW** for the first time, 0.80kHz is displayed on the **BFO & CLARIFIER** indicator.
- (3) Set the desired receiving frequency by using the **MHz** knob, the **UP/DOWN** switch and **TUNE** knob.
- (4) When the numerical number within  $\pm 0.4\text{kHz}$  is displayed on the **BFO & CLARIFIER** indicator, adjust the **BFO & CLARIFIER** knob so that the numerical number will be within the range between  $\pm 0.6$  and  $1.0\text{kHz}$ .
- (5) Press the **0.5kHz** button among the **BANDWIDTH** switches (in case of NRD-93, press the **1kHz** button).
- (6) Set the **RF GAIN** knob almost to the center position and the **AGC** switch to **OFF**.
- (7) When hearing the desired signal, set the volume to the optimum level by adjusting the **AF GAIN** knob.

- (8) By adjusting the **BFO & CLARIFIER** knob, set the tone most pleasant to hear.
- (9) Adjust **RF GAIN** and **AF GAIN** so that S/N of the receiving signal through the speaker will be the best.
- (10) When the receiving wave is affected by fading or the strong wave and weak wave are received reciprocally, set the **AGC** switch to **FAST** and turn the **RF GAIN** knob slightly clockwise.

#### 4.3.3 Operation of DSB reception

- (1) Press the **DSB** button among **MODE** switches, and **6kHz** button among **BANDWIDTH** switches.
- (2) Set the **RF GAIN** knob to the maximum position and set the **AGC** switch to **FAST**.
- (3) Set the desired receiving frequency by using the **MHz** knob, **UP/DOWN** switch and **TUNE** knob.
- (4) By adjusting the **AF GAIN** knob, set the volume to the optimum level.
- (5) In case of strong interference, press the **3kHz** button among **BANDWIDTH** switches.

#### 4.3.4 Operation of FSK reception

A teleprinter and FS demodulator are adaptative to this receiver to receive a FSK signal. Receive the FSK signal in the following procedures.

- (1) Press the **FSK** button among **MODE** switches.
- (2) Select the proper **BANDWIDTH** button in accordance with the frequency shift width and modulation speed of an FSK signal under reception. In case of the narrow band direct printing telegraph, select **0.5kHz** or **0.3kHz**.
- (3) Set the **AGC** switch to **SLOW** and the **RF GAIN** knob to the maximum position (fully clockwise).
- (4) Set the desired receiving frequency by using the **MHz** knob, **UP/DOWN** switch and **TUNE** knob.
- (5) After receiving the signal, adjust the **AF GAIN** knob so as to obtain the desired volume, as required.
- (6) Set the **METER** switch located on the front panel of the FS demodulator to **TUNE**.
- (7) Adjust the **BFO & CLARIFIER** knob so that the **TUNE** meter of the FS demodulator deflects maximumly and LEDs of both **MARK** and **SPACE** blink in the same brightness.

**NOTE:** When performing the teletype communication by connecting this receiver to the narrow band direct printing terminal, be sure not to change the **BANDWIDTH** after the circuit is connected once. Otherwise, it may happen that the phase is out due to the difference of the delay time of the filter.

#### 4.3.5 Operation of FAX reception

A radio facsimile equipment is also adaptative to this receiver to receive the FAX signal.

Receive the FAX signal in the following procedures.

- (1) Press the **FAX** button among **MODE** switches.
- (2) Select the proper **BANDWIDTH** button in accordance with the modulation speed and frequency shift width of the FAX signal under reception.  
In case of the broad band facsimile such as weather facsimile, etc., press **3kHz**.

- (3) Set the **AGC** switch to **FAST** and the **RF GAIN** knob to the maximum position (fully clockwise).
- (4) Set the desired receiving frequency by using the **MHz** knob, **UP/DOWN** switch and **TUNE** knob.
- (5) After receiving the signal, adjust the **AF GAIN** knob so as to obtain the desired volume, as required.
- (6) Adjust the **BFO & CLARIFIER** knob so that LEDs for tuning, located on the front panel of the facsimile recorder, **TUNE 1** and **TUNE 2** will light the most brilliantly in the same brightness.

#### 4.3.6 Further operation

- (1) Operation of noise blanker (NB)

When the signal is hard to be heard since the pulse noise such as the ignition noise, atmospherics, etc. interferes the signal, set the NB switch to ON. But since the pulse noise such as very weak noise, very strong noise, the pulse with the very short reciprocal cycle, pulse with the very broad width, are difficult to be distinguished from the normal signal, the noise blanker circuit can't suppress the noise. In case of the strong pulse noise, set the **ATT** (described later) to **ON**.

- (2) Operation of ATT

The receiving antenna catches many kinds of radio wave from the strong one to weak one. If many strong waves arrive at the high frequency stage of the receiver, interferences such as intermodulation, blocking, cross modulations and so on arise, so that sometimes the desired radio waves can't be received well. Also, when the partner stations located very close to own station, the sound is distorted because the AGC circuit can't control such a strong radio wave. In such a case, by setting **ATT** to **ON**, the receiving condition is greatly improved. If **S** meter deflects, the desired radio wave can be received even though **ATT** is set to **ON**.

Especially, when receiving the radio wave below 1.6MHz, it is recommended to always set **ATT** to **ON** except at the stand-by condition.

- (3) Operation of AF filter

If it is hard to hear the sound when receiving the signal with low S/N, set **AF FILTER** to **ON**. The frequency band of the AF amplifier stage becomes narrower, so that S/N of the output sound will be improved.

- (4) Operation of PBS in USB mode

Use PBS function when an interference exists near the desired signal (only for NRD-93).

- a) In case of interference at the higher frequency side (USB mode)

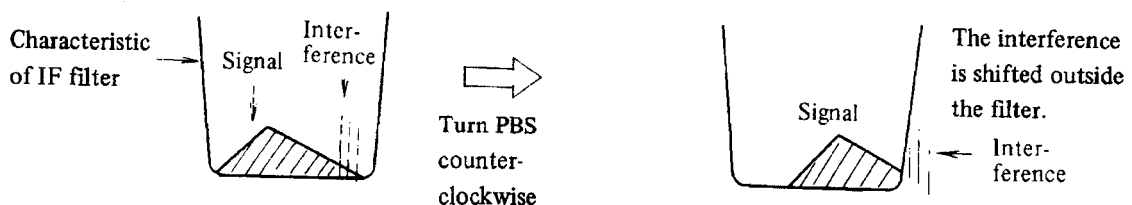

In this case, the spectrum of the signal is also cut, so that the demodulated sound quality will deteriorate a little.

- b) In case of interference at the lower frequency side

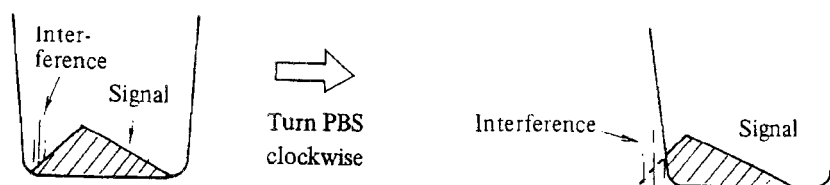

- c) In case of interference at both sides

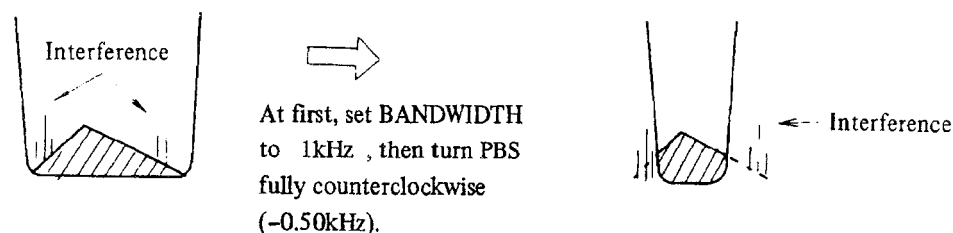

Even though setting the **BANDWIDTH** to 1kHz, the intelligibility of the sound will remain to some extent by operating PBS. Thus, this method is very effective not only for interference but also for very noisy receiving signals.

- d) Operation of PBS in modes other than USB, PBS works effectively in CW, DSB, FSK and FAX modes, too. Operate PBS in the same manner as those in the USB mode. Especially, in the CW mode, using PBS with setting the **BANDWIDTH** switch to **0.3kHz** gives the excellent separation characteristic.
- e) At the stand-by condition, return PBS to the center position (0kHz). Otherwise, the receiver may not be able to receive the signal because that frequency is outside the band of the filter when the frequency of the radio wave of the partner station is largely different from the nominal value. When changing the bandwidth, **PBS** is reset automatically to 0kHz (electrically).
- f) The variation range of PBS is automatically limited as shown in the following table, according to the selected bandwidth. But the knob can turn endlessly.

BAND	0.3kHz	1kHz	3kHz	6kHz	AUX
Variable range	±0.12kHz	±0.5kHz	±1.2kHz	±2.0kHz	±0.08kHz

(5) Reception of DSB signal in the SSB mode

If there is an interference or only carrier is faded when receiving the DSB signal of the SW broadcasting, etc., the DSB signal may be received better in SSB mode (in case of NRD-93, USB or LSB mode) than in DSB mode. For example, assuming to receive the broadcasting of 6055kHz, set the mode to SSB (USB/LSB) at first. 6253.5kHz appears on the frequency indicator (in case of the LSB mode, 6256.5kHz). Then, set the frequency to 6055.00kHz again by turning the TUNE knob. Set the tone the most natural to hear by turning **BFO & CLARIFIER**. It is recommended to set **AGC** to **SLOW**. If required, set **BANDWIDTH** to **3kHz**. Now DSB signal must be received better than in DSB mode. In case of NRD-93, use the side band, which has less interference by selecting either LSB or USB.

The BFO circuit, which performs 1Hz step control by using the phase-locked loop, can ensure such an attractive receiving method to NRD-92/93.

(6) Operation of AGC switch

In the **SLOW** position of **AGC** switch, the discharging time constant is set to about 3 seconds so as to suppress the noise between communications in the SSB mode, so that the pleasant communication can be obtained.

When performing the ARQ communication by connecting a direct printing telegraphy equipment, or receiving the Morse telegraph affected by moderate fading, the **SLOW** position seems to give better result, too.

However, if the receiver is called by the weak signal promptly after the strong wave is received, the signal may not be able to hear since the gain is not recovered yet. Therefore, when communicating with the ship at a far distance and the one at a near distance by turns, set the **AGC** switch to **FAST**.

Also when performing the search reception by operating the **TUNE** knob, set the **AGC** switch to **FAST**. S meter reacts more rapidly in the **FAST** position than in the **SLOW** position, and the most suitable tuning point can be found easily.

(7) Memory of the indication data

a) BFO & CLARIFIER indication when changing the mode

For example, if setting the **BFO** indication to **.85kHz** in the CW mode and next changing the mode to **SSB**, the BFO & CLARIFIER indication will be CLARIFIER. Then, if setting the indication to **.050kHz** by operating the knob, and resetting the mode to CW, the BFO & CLARIFIER indication will be **.85kHz**. Furthermore if setting the mode to SSB again, the indication will return to former **.050kHz**.

b) Indication when turning on the power again after turning off the power

All indicators show the same informations as they were before turning off the power.

(8) Program of the internal preset channel (NRD-93)

Program the internal preset channel in the following procedures.

Example: Assuming to program 12850.00kHz, USB, and 3kHz in 5ch of group A:

- a) Set the CH/MHz switch to **MHz** (center position).
- b) Press the USB button among **MODE** switches, and 3kHz among **BANDWIDTH** switches respectively.
- c) Set the frequency to 12850.00kHz by using the **MHz** selector knob, **UP/DOWN** switch and **TUNE** knob.
- d) Keep pressing the **CH/MHz** selector switch to **READY**.
- e) Set the A/B group selector switch to A.
- f) Select 5ch by using the **MHz** selector knob. (Keep pressing **CH/MHz** selector switch to **READY**.)
- g) Keeping the switch to **READY**, press the **MEMO** switch.
- h) Let go your hold of the switch (release the switch from **READY**).

With above operations, 12850.00kHz, USB mode and 3kHz are programmed in 5ch of group A. Other channels can be programmed in the same procedures.

Newly programmed contents of the channel can be confirmed by setting the **CH/MHz** switch to **CH** position.

## 5. CIRCUIT DESCRIPTION

### 5.1 Receiving Section

The circuit composition of this receiver is shown in the appended block diagram.

The receiving system is a double-superheterodyne type with a first intermediate frequency of 70.455MHz and a second intermediate frequency of 455kHz. All local signals of the receiver are supplied from the digitally controlled frequency synthesizer which is of phase-locked loop (PLL) with a reference oscillating frequency of 10MHz.

A receiving frequency signal of 90kHz to 29.99999MHz is supplied to the high frequency input tuning circuit after passing through the BK relay and the input protection circuit. When the relay of the input attenuator is operating, a 20dB attenuator is inserted to the signal route at the former stage of the tuning circuit.

The tuning circuit is composed of eight double tuning circuits using the capacitor diodes, and covers all receiving frequency range. Each double-tuning circuit divides the assigned frequency range by two and tunes. The built-in microcomputer controls the selection of the tuning circuit and the bias voltage to the capacitor diode, corresponding to the set receiving frequency.

The signal thus supplied to the double tuning circuit passes through the 35-MHz low pass filter. The signal then is fed through the wide band RF amplifier into the first mixer.

In the first mixer, the receiving signal is mixed with the local frequency signal of 70.545MHz to 100.45499MHz delivered from the synthesizer and is thereby converted into the first intermediate frequency of 70.455MHz.

The converted output passes through the crystal filter with a center frequency of 70.455MHz and a bandwidth of 12kHz, and then is amplified by the first intermediate frequency amplifier. Then, it is supplied to the second mixer, in which the receiving signal is mixed with the local frequency signal of 70MHz delivered from the synthesizer and is converted into a second intermediate frequency of 455kHz.

The converted output from the 2nd mixer is supplied to the input of the noise blanker gate after passing through the ceramic filter with a center frequency of 455kHz and a pass-band width of 25kHz. The other converted output passes through the noise blanker circuit composed of the noise amplifier, AGC detector, AGC amplifier, noise detector and noise blanker gate control amplifier and becomes the signal to control the noise blanker gate.

When the NB switch on the front panel is set to the operating condition, the noise blanker gate closes according to the pulse width of the impulsive noise and the signal route is interrupted temporarily, if the noise blanker circuit detects the impulsive noise.

The receiving signal, which have passed through the noise blanker circuit, passes through the selected one of the four filters with the nominal bandwidths of 6kHz, 3kHz, 1kHz and 0.3kHz, and the filtered signal is amplified by the 455kHz 2nd intermediate frequency amplifier.

The amplified output is supplied to AGC circuit, intermediate frequency output circuit and demodulating circuit respectively. AGC voltage for automatic gain control is applied to the high frequency amplifier.

455kHz intermediate frequency output is supplied to IF OUT connector on the rear panel. In case of DSB detection, the demodulating circuit takes out the carrier component from the receiving signal and operates as a synchronous detector. In case of other than DSB detection, the BFO signal for demodulating is supplied from the synthesizer section and the demodulating circuit operates as a product detector.

One demodulated output is supplied to the AF power amplifier for the speaker and headphone after passing through the AF GAIN controller on the front panel. When AF FILTER switch on the front panel



is set to the operating condition, the band pass filter is inserted into the signal route at the former stage of the AF power amplifier.

The other demodulated output is supplied to the line amplifier after passing through the semifixed resistor, and is connected to BK & LINE connector on the rear panel as the balanced line output with a center tap.

The BK signal supplied from the external equipment is supplied to the BK control circuit after passing through the photo coupler. The BK control circuit controls the BK relay in the RF input and AGC circuit in the 2nd IF amplifier.

The meter on the front panel is driven by the AGC voltage when the meter switch is set to S. On the other hand, when the meter switch is set to LINE, the meter amplifier amplifies a part of line amplifier output and this amplified output is detected by diodes. The meter is driven by this detected DC output.

The power supply circuit supplies the power to each circuit of the receiver; +15V is supplied as the power supply of IC for the AF power amplifier, +17V is supplied as the power supply of the semiconductor circuits such as transistor, FET and linear IC, etc. and +24V is supplied as the power supply for relay driving.

## 5.2 Synthesizer Section

The synthesizer in this equipment generates the first local signal of 70.545MHz to 100.45499MHz corresponding to the receiving frequency from 90kHz to 29.99999MHz, the 2nd local signal of 70MHz and demodulating BFO signal in 455kHz band, and provides those frequencies to each circuit.

As shown in the block diagram in Fig. 5-1, the synthesizer consists of a LOOP 1, REF & LOOP 2 and LOOP 3 & BFO circuits. These circuits are accommodated in three plug-in type printed circuit boards.

BFO signal, which is applied to the demodulator in the receiver section, is generated by the BFO loop shown in the block diagram in Fig. 5-1.

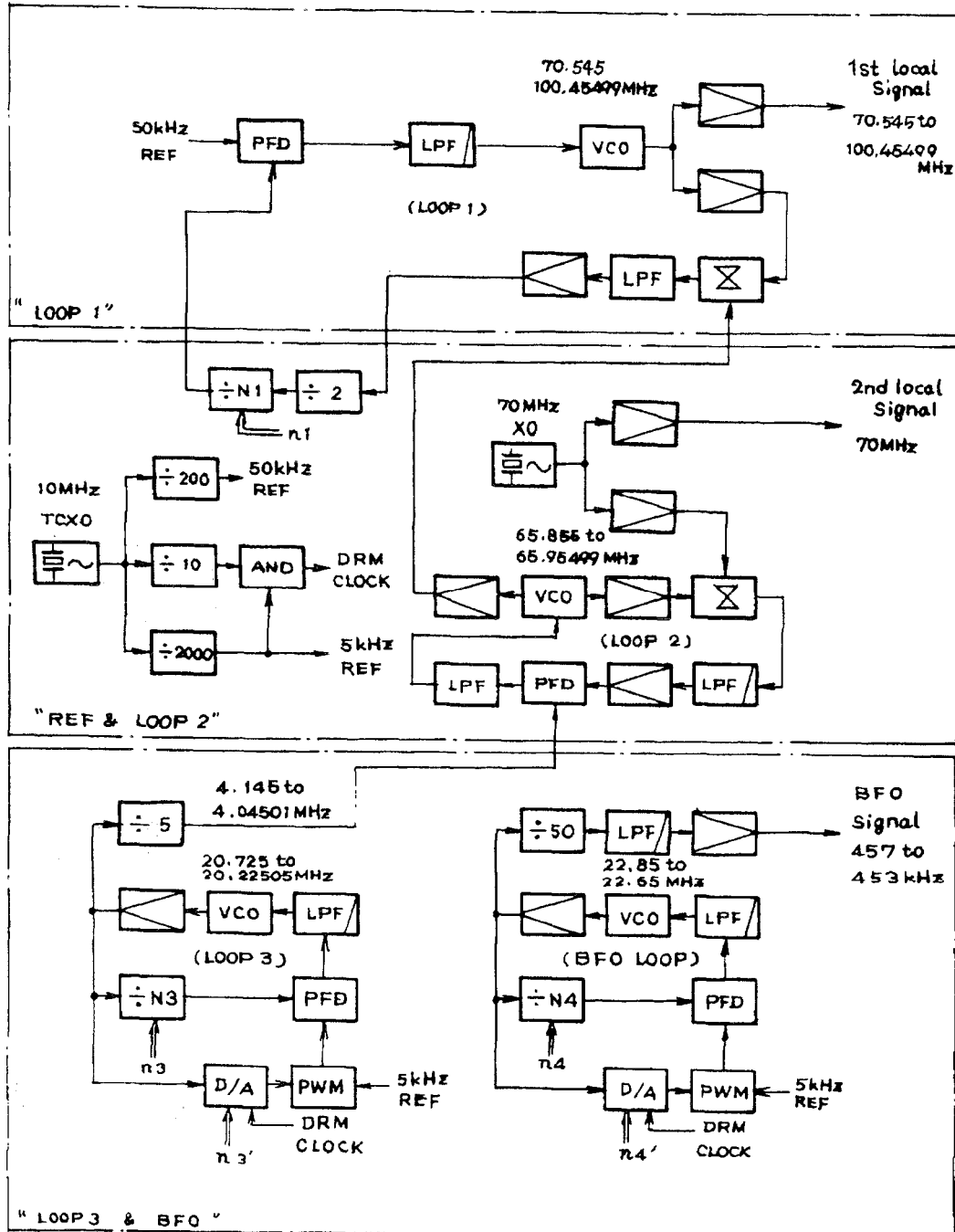

Fig. 5.1 Blockdiagram of Synthesizer

BFO loop is the phase-locked loop which is of the fractional dividing system whose reference signal is 5kHz. This BFO loop generates frequencies shown in Table 5-1 according to the receiving mode and the information set by BFO & CLARIFIER on the front panel.

Reception mode	BFO output frequency	
FAX	456.9kHz <sup>+0</sup> <sub>-9</sub> Hz/1Hz step	
FSK	456.7kHz "	
CW	455 ±2kHz/10Hz step	
USB	456.5kHz <sup>+0</sup> <sub>-9</sub> Hz/1Hz step	SSB in case of NRD-92
LSB	453.5kHz "	Only NRD-93

**Table 5-1 Output Frequency of BFO Loop**

The voltage control oscillator (VCO) in the BFO loop provides the frequency ranging from 22.85MHz to 22.65MHz in minimum 50Hz intervals.

The oscillating frequency of VCO is controlled by the set value n4 given to variable divider N4 and the set value n4' given to D/A converter. The reception mode, and information obtained by the BFO & CLARIFIER knob on the front panel are calculated by the micro computer and its calculated values are used as n4 and n4'.

The output signal of VCO is supplied to the modulator in the receiver section as the BFO signal after passing through the buffer amplifier, 1/50 fixed divider, LPF and tuning amplifier.

The loop 3 circuit shown in the block diagram in Fig. 5-1 is also the fractional dividing phase-locked loop in which the reference frequency is 5kHz. This loop 3 circuit generates the frequencies of 4.145MHz to 4.04501MHz according to the receiving frequency and information given by the BFO & CLARIFIER knob. VCO in the loop 3 circuit provides frequencies ranging from 20.725 to 20.22505MHz in minimum 50Hz intervals. The oscillating frequency of VCO is controlled by the set value n3 given to the variable divider N3 and n3' given to D/A converter.

The VCO output is supplied to the buffer amplifier and divided by 5 by the fixed divider. Thus this output becomes the signal in 10Hz intervals and is supplied to the phase-frequency detector (PFD) in the loop 2 circuit.

REF & loop 2 circuit consists of the reference signal generator, divider of loop 1, 2nd local oscillator and loop 2 circuit. The output signal of a 10MHz temperature-compensated crystal oscillator (TCXO) is divided by 1/200 fixed divider and 1/2000 fixed divider, and reference signals of 50kHz and 5kHz are generated. The reference signal of 50kHz is supplied to PFD in loop 1 and the 5kHz reference signal is supplied to the pulse width modulators (PWM) in loop 3 and BFO loop. The signal obtained by dividing 10MHz by 10 is sampled by 5kHz reference signal and becomes pulse train. Then, this signal is sent to DRM in the D/A converter in loop 3 and BFO loop as a clock signal.

The output signal of 70MHz crystal oscillator (XO) is fed to the 2nd mixer in the receiver as the local signal via the buffer amplifier and also fed to the heterodyne converter in loop 2.

In the receiver section, in the process where the receiving frequency is frequency-converted to the 2nd intermediate frequency (455kHz) by the 1st mixer and the 2nd mixer, the frequency drift component of 70MHz crystal oscillator is cancelled. Therefore, the frequency stability of this crystal oscillator does not affect the over-all frequency stability of the receiver. Thus, the over-all frequency stability of the receiver depends on only the frequency stability of 10MHz crystal oscillator.

The loop 2 circuit forms the phase-locked loop. VCO is controlled by the frequencies ranging from 4.145MHz to 4.0450MHz in 10Hz intervals, which is supplied from loop 3 circuit, and VCO generates frequencies of 65.855 to 65.95499MHz.

The operation of loop 2 circuit is equivalent to the operation of up converter converting the input signal from the loop 3 circuit by the 70MHz local signal. The output frequency is equal to the difference between frequencies of two signals.

The output signal of VCO is fed to the heterodyne converter in the loop 1 circuit, after passing through the tuning amplifier.

The loop 1 circuit mainly consists of VCO, heterodyne converter, divider and phase frequency detector. But the divider, composed of 1/2 fixed divider and variable divider, is physically accommodated in the plug-in unit of REF & loop 2 circuit.

The oscillating frequency of VCO is controlled by the set value n1 given to the variable divider N1 and the output signal of loop 2 circuit. The set value n1 is given from the microcomputer according to the receiving frequency information.

One output of VCO, controlled by the minimum step of 10Hz, is amplified by the buffer amplifier and supplied to the first mixer in the receiver section as the local signal. The other output is supplied to heterodyne converter in the loop.

For the power supply to each circuit in the synthesizer section +5V is supplied to the digital IC, and +17V is supplied to semiconductor circuits such as transistor, FET and linear IC, etc.

### 5.3 Control Section

The control section provides functions such as the function generating the signal required for controlling the receiver section and synthesizer section, described in paragraphs 5.1 and 5.2, according to the panel operation, information exchange function with the external units (scanning unit, timer unit, etc.) and indication control function of information. This section is mainly composed of controls on the front panel and microcomputer.

The microcomputer receives informations from controls on the front panel, such as MHz, BFO & CLARIFIER, TUNE, UP/DOWN, LOCK, MODE and BANDWIDTH informations as shown in the appended block diagram of the receiver. The microcomputer, furthermore, can receive informations sent in serial from the external units.

The microcomputer generates the band selection information (coded 4-bit information), based on the informations from controls of MHz, BFO & CLARIFIER, TUNE, UP/DOWN etc. concerning the receiving frequency and also generates the tuning voltage via the D/A converter and controls the tuning circuit of the receiver. Also this CPU controls the bandwidth selection of the IF filter by coding the selection information of the BANDWIDTH switch to 3 bits.

The microcomputer transfers the frequency setting information to loop 1, loop 3 and BFO loop in the synthesizer section via the bus line according to the information for the receiving frequency and reception mode, and controls each phase-locked loop.

The microcomputer also processes informations received from the controls on the front panel, and then sends the display information to BFO & CLARIFIER indicator, receiving frequency indicator, MODE indicator and BANDWIDTH indicator via the bus line.

When the external units are connected to PRESET connector on the rear panel, the microcomputer sends the information for the frequency, reception mode and bandwidth with the code format shown in Fig. 5-2, in serial at a speed of 2400 bits/sec., according to the request of the external unit.

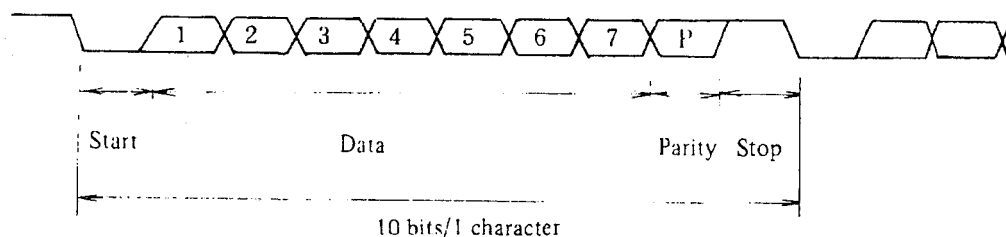

Fig. 5-2 Code format of serial data

When the power line is suddenly interrupted or the power supply is stopped, the microcomputer writes the required information in the memory element backed up by the built-in battery, as the misoperation protection function. Therefore, the conditions before the power trouble happens can appear on indicators, when the power line returns to the correct condition.

However, input attenuator, noise blanker, AGC, meter selection, and AF filter placed in the receiver, and dimmer function of the indicating circuit are controlled directly by each control on the operation panel, irrespective of the CPU operation.

#### **5.4 Power Supply Section**

The power supply section supplies the DC voltage required for the operations of the receiver section, synthesizer section and control section by converting voltage of the external AC power supply or the DC power.

The power section supplies 4 kinds of DC voltages; +24V for driving relays, +17V for analogue circuit, +15V for AF power amplifier and +5V for digital circuit.

Among those power voltages, +17V and +15V are stabilized by the series regulators and +5V is stabilized by the switching regulator.

## 6. MAINTENANCE AND CHECK

### 6.1 General Description

The receiver and synthesizer circuits are mounted on the plug-in type printed circuit boards, thus facilitating repair and replacement of defective circuit. Be sure to turn off the power switch when removing each plug-in type printed circuit board. It is noted that tools required for removing each printed circuit board are attached to the chassis.

The front panel is coupled with the chassis through three connectors and hence demountable with ease.

This receiver consists of the following sections in principle : receiver section, synthesizer section, control section, and power supply section. But physically, this receiver is taken to the following pieces; top cover, bottom cover, handles attached to the right and left sides on the front panel, 8 plug-in type printed circuit boards, front panel unit and main chassis.

It is essential for keeping the equipment always in the best operating condition and performing the proper maintenance and check to know the basic operating principle and correct operating condition of the equipment, ordinarily.

### 6.2 General Maintenance and Check

Table 6-1 shows the general maintenance and check using tester and some tools.

No.	Item	Maintenance and check
1	Cleaning	For cleaning the panel surface, knobs, switches, top cover and bottom cover, wipe off the stain with a soft cloth or silicon cloth. For the inside of the set, remove the dust with a brush or cleaner. Since no gear is equipped, lubrication is not required.
2	Looseness of parts	Check whether screws and nuts are loosened, knobs, switches and volumes are loosened, connectors are loosened and relays and ICs inserted into sockets are surely inserted, or not. Fasten them firmly and attach them surely.
3	Fuses	When fuses for the power supply blow, check the cause carefully and replace them. 1-ampere glass-tube fuse is used for AC power and 3-ampere glass-tube fuse for DC power (included in the spare parts).
4	Printed circuit board	Remove the plug-in type printed circuit board, and check whether the parts mounted on the PC board discolor or are burnt or not. When replacing parts, use the spare parts. When replacing the part excluded in the spare parts, give an order for parts to the sales agent or service station of JRC. When giving an order for the parts, please tell the circuit name of PC boards on which that part is mounted, and part No. correctly.
5	DC voltage	Check the DC voltage at the power input of the motherboard of the bottom of chassis by means of the tester. The standard values are +17V, +24V, +15V and +5V.

Table 6-1 Maintenance and Check

Four lock indicators by LEDs are provided on the top part of 3 PC boards of the synthesizer.

By inspecting the lock indicators with eyes through the hole placed on the top cover of the receiver, the operation of the synthesizer can be checked.

Four lock indicators correspond to four phase lock loops (BFO loop, loop 3, loop 2 and loop 1) described in paragraph 5.2. When those phase-locked loop operate correctly, all indicators go out. The lock indicators serve for locating a defective part in the synthesizer, as described in the following table. When an indicator is lighting, the receiver becomes muted.

Indicator				Defective circuit	PC board
BFO	LOOP 3	LOOP 2	LOOP 1		
ON	OFF	OFF	OFF	BFO loop	LOOP 3 & BFO
OFF	ON	ON	OFF	Loop 3	"
OFF	OFF	ON	ON	Loop 2	REF & LOOP 2
OFF	OFF	OFF	ON	Loop 1	LOOP 1
OFF	ON	ON	ON	Reference signal or others	REF & LOOP 2

**Table 6-2 Lighting Condition of Lock Indicators**

- Notes) 1. ON indicates the lock indicator lights, while OFF indicates the lock indicator goes off.  
 2. When changing the receiving frequency, the lock indicator instantaneously lights some-times, this, however, is not a trouble.

When one of LEDs light, check the defective PC board according to the above table and tell the name of the PC board correctly to JRC sales agent.

**NOTE:** When removing a PC board from the main chassis, be sure to turn off the power switch, and remove a PC board with two levers attached to the chassis.

### 6.3 Troubleshooting

A few kinds of troubles may happen sometimes while using a receiver for a long period. Some troubles are due to the receiver itself, but some of them may be caused by reasons other than the receiver. Thus, even if the receiver is under a trouble condition, do not conclude that the trouble is due to the receiver without checking the cause by yourself. Check the cause of a trouble according to the troubleshooting before contacting with JRC or JRC's sales agent or service station. The inspecting methods for typical troubles are described below.

#### 6.3.1 Decline of the sensitivity

The word "Sensitivity" is used ambiguously among users. In this section, the decline of sensitivity means not only that the sound volume is not large but also that S/N of the output signal of the receiver reduces.

##### Explanation

For some constant high frequency input signal, the sound volume does not depend on the performance of the receiver. This depends only on the gain from the input stage to the AF output stage of the receiver.

For example, "the former receiver could produce the sound loudly enough with RF GAIN set to 8 graduation and AF GAIN to 2. But the present receiver can't produce the sound loudly with the same gain settings, unlike the former receiver. This receiver has very bad sensitivity." This doesn't make sense at all. The effectiveness of RF GAIN volume and AF GAIN volume for the setting gradation is different among makers. Even in case of the same model receivers, there are some differences. Also, even though

the distance from the partner station and frequency are the same, the wave strength varies largely depending on the year, season, time, etc. Thus, in order to compare the sensitivity of the receivers, S/N of the receiver must be compared between receivers under the following conditions: Connect the same antennas to the receivers to be compared, and receive the same frequency at the same time, by setting the speaker sound volume to the almost same level.

#### Checking procedure

- (1) Check whether the receiver is misoperated or not. Check whether ATT is set to ON, or not. Receive the radio wave in other frequency band. When the sensitivity is very bad in the special band, receive that radio wave by other receiver, if possible. If the difference is remarkable between receivers when receiving the same signal in the same time by the same antenna, it can conclude that the trouble is due to the receiver itself. If that difference is not remarkable, that is not the trouble of the receiver itself. This difference depends on variation in receivers.
- (2) When the sensitivity reduces even if the frequency band is changed, start the check from the antenna system. When an antenna multi-coupler or antenna changer is inserted between the antenna and receiver, connect the antenna directly to the receiver. If the sensitivity is still bad, connect another antenna to the receiver. If the sensitivity is greatly improved when connecting the antenna directly to the receiver, check the cable, antenna multi-coupler and antenna changer successively.
- (3) When it is confirmed that the receiver itself is bad, replace the BK relay of the receiver and/or high frequency input circuit CFL-176.

#### 6.3.2 No sound

The sound does not come through the speaker even though the speaker is connected to the receiver correctly, and no defects have been found in the speaker and indications of the receiver. In such case, check the receiver in the following procedures.

#### Checking procedure

- (1) Remove the BK & LINE connector from the receiver.  
If the sound comes out through the speaker, -BK is grounded somewhere in the BK line.  
Check wirings of other receivers, transmitters and consoles to which -BK line is connected in parallel.
- (2) Lock-out check of the synthesizer  
Take out the receiver from the cabinet case or rack, and check LEDs from the top after turning on the power (see table 6-2).

#### 6.3.3 Noise and beat

Even though changing the receiving frequency band, noise or beat sound comes through the speaker. But that noise is evidently not external noise.

Especially, in the small ship, many kinds of electronic equipments are mounted in the small room, so that the mutual interference may happen among equipments. In many cases, the receiver suffers interference. When the mutual interference arises, search the surrounding for the source of noise. Especially, when mounting a new electronic equipment, you must check whether the new equipment give the noise interference to the receiver or not.

#### Checking procedure

- (1) Investigation of the source of noise  
At first, set the receiver to such a condition where the noise comes out through the speaker. Turn off the power of the equipments other than the receiver successively. If the noise stops when turning off the power of some equipment, it is considered that this equipment is the source of the noise. Sometimes, the power supply itself may generate the high frequency noise, not the electronic equip-



ment. In such a case, change the power system.

(2) Investigation of the route of noise

After checking the noise source, the route of the noise must be investigated.

The noise routes are largely classified as shown in the figure.

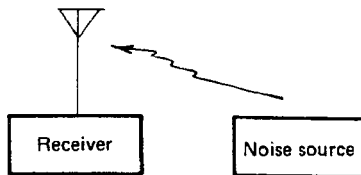

The noise goes to the antenna.

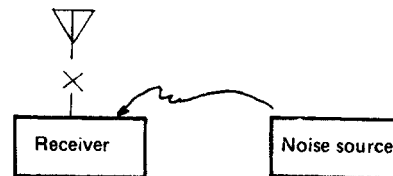

The noise goes directly to the receiver.

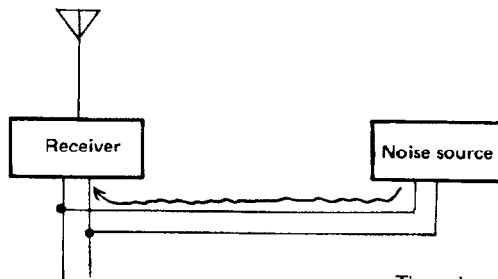

The noise goes to the receiver via the power cable.

By removing the antenna, connecting the receiver to other antenna, changing the power system and moving the installation place, the route can be found.

(3) Countermeasure

Basically, the countermeasure must be taken at the noise source side. In any cases, all equipments must be grounded. If the equipment is surely grounded by means of the wide copper board, the noise interference may be resolved. Also, a line filter which suppresses the HF noise is very effective at the power supply wire. After finding the noise source and noise route, please examine the trouble and ask the countermeasure to the maker or sales agent of that equipment which is of the noise source.

### 6.3.4 Interference by the transmitter of own station

At the station where many radio equipments are installed, when some transmitter transmits the radio wave, the receiver may catch the noise in spite of that frequencies are different. It is a rule that the receiver is muted while transmitting by using -BK signal. But when performing the simultaneous transmission and reception because of the duplex communication, it is important to separate transmitting antenna and receiving antenna as far as possible. Even though the antennas are located at the same distance from the transmitting antenna, the receiving antenna located not in parallel to the transmitting antenna has less interference.

Generally, the interference depends on the difference between receiving frequency and transmitting frequency. The bigger the difference is, the less the interference is. Also, the degree of the interference depends on the performance of the antenna multi-coupler, protective diode, etc.

#### Checking procedure

(1) Connect other antenna

Change the receiving antenna to the one placed at the position as far as possible from the transmitting

antenna which interferes the receiver.

- (2) When the antenna multi-coupler is used, connect the antenna directly to the receiver.
- (3) When the arrester-diode is mounted in the antenna system, add the same diodes in serial so as to increase the number of the diodes. (See paragraph 6.3.5.)

When the interference does not disappear even after checking with the above procedures, no counter-measure is effective. Thus, leave the record for the degree of interference, transmitting frequency and receiving frequency for future convenience, and avoid such a combinations of frequencies with the terrible interference. The receiver itself is designed so as to amplify enough even a signal of  $1\mu\text{V}$ , so that it can't be avoided that the some extent of interference occurs in the simultaneous transmission and reception when antenna installation places can't be separated enough in the small ships, etc.

### 6.3.5 Intermodulation

While receiving some frequency, it sometimes happen to hear several signals which can't be radiated by that frequency. This phenomenon is caused by intermodulation.

#### Checking procedure

- (1) When the antenna multi-coupler is connected to the receiving antenna for receiver, connect the antenna directly to the receiver.

If the above phenomenon disappears, it can be considered that the intermodulation arises at the antenna multi-coupler.

- (2) When the phenomenon does not disappear even though the receiver is connected to the antenna directly, check whether arrester-diode is inserted on the way of the feeder line, or not. If inserted, remove that arrester-diode and then receive the signal (at this time, do not operate the transmitter). If the phenomenon disappears by removing the arrester-diode, add arrester-diodes more or replace them with other type protecting element.

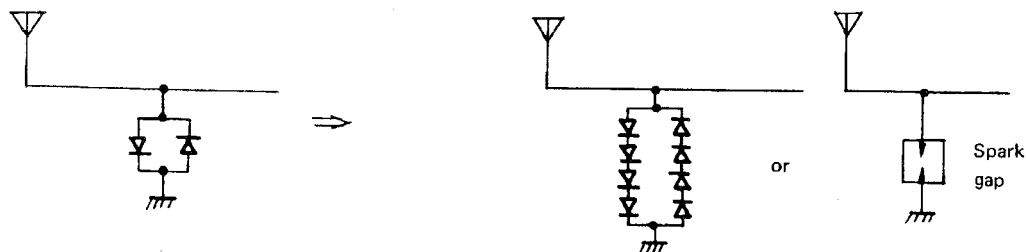

- (3) When the phenomenon does not disappear even though the receiver is connected to the antenna directly and the arrester-diodes are removed, this is caused by the trouble inside the receiver. At first, remove the arrester-diodes mounted on the input tuning circuit (CFL-176). When the phenomenon does not disappear still now, turn on the attenuator of the receiver.

#### Explanation

##### Intermodulation

Some radio waves with different frequencies are frequency-converted due to the antenna multi-coupler, arrester-diodes and the non-linearity of amplifiers and mixers in the receiver. This frequency-converted radio wave corresponds to the receiving frequency and interferes the reception. This phenomenon is called intermodulation. For example, assuming that the receiving frequency  $f_D$  is  $f_D = 3855\text{kHz}$ , and other strong interference wave  $f_{u1}$  is  $f_{u1} = 3925\text{kHz}$ ,  $f_D = 2f_{u1} - f_{u2}$ . If  $f_{u2}$ , in which a relation of  $3855\text{kHz} = 7850\text{kHz} - f_{u2}$  exists (in this case,  $3995\text{kHz}$ ), is very strong, the mixed signal of  $3925\text{kHz}$  and  $3995\text{kHz}$  will be heard through the receiver which is set to  $3855\text{kHz}$ .

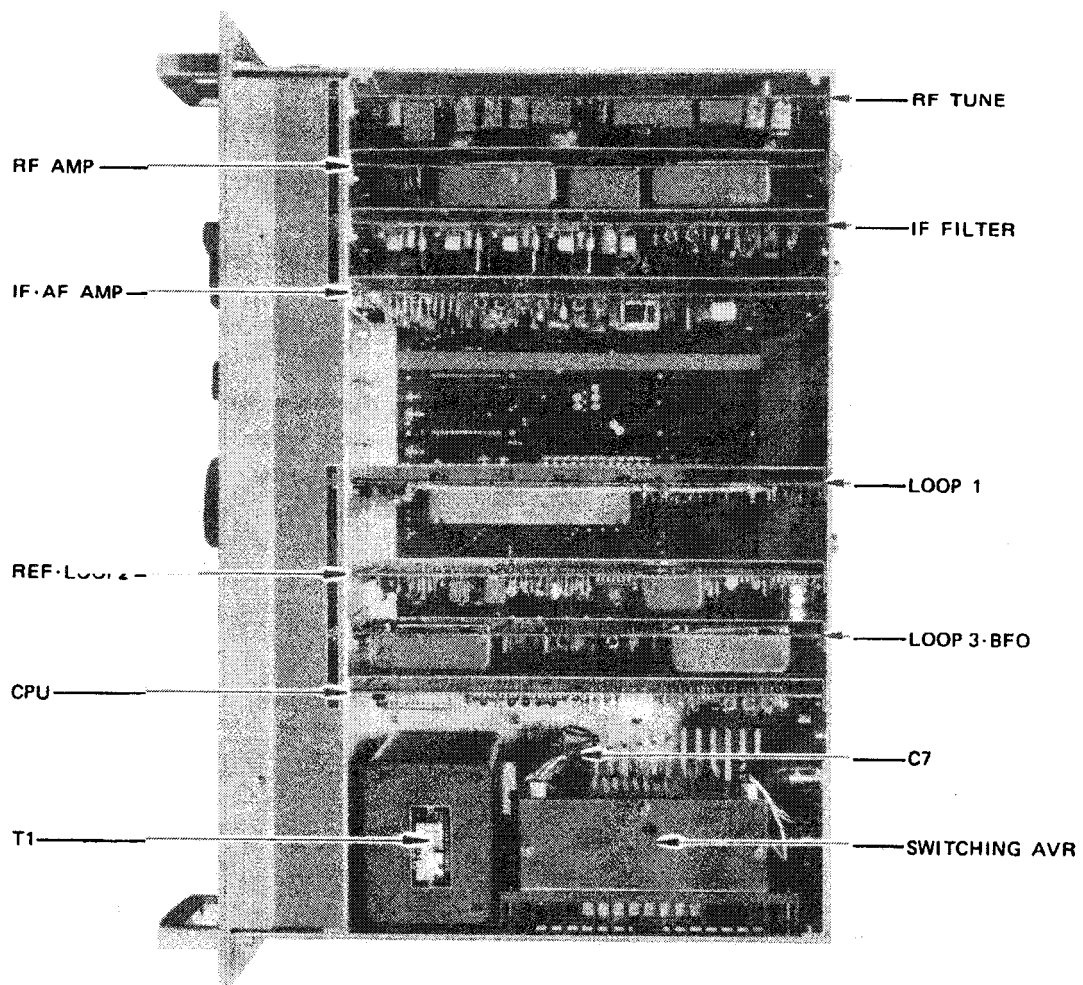

TOP PARTS ARRANGEMENT

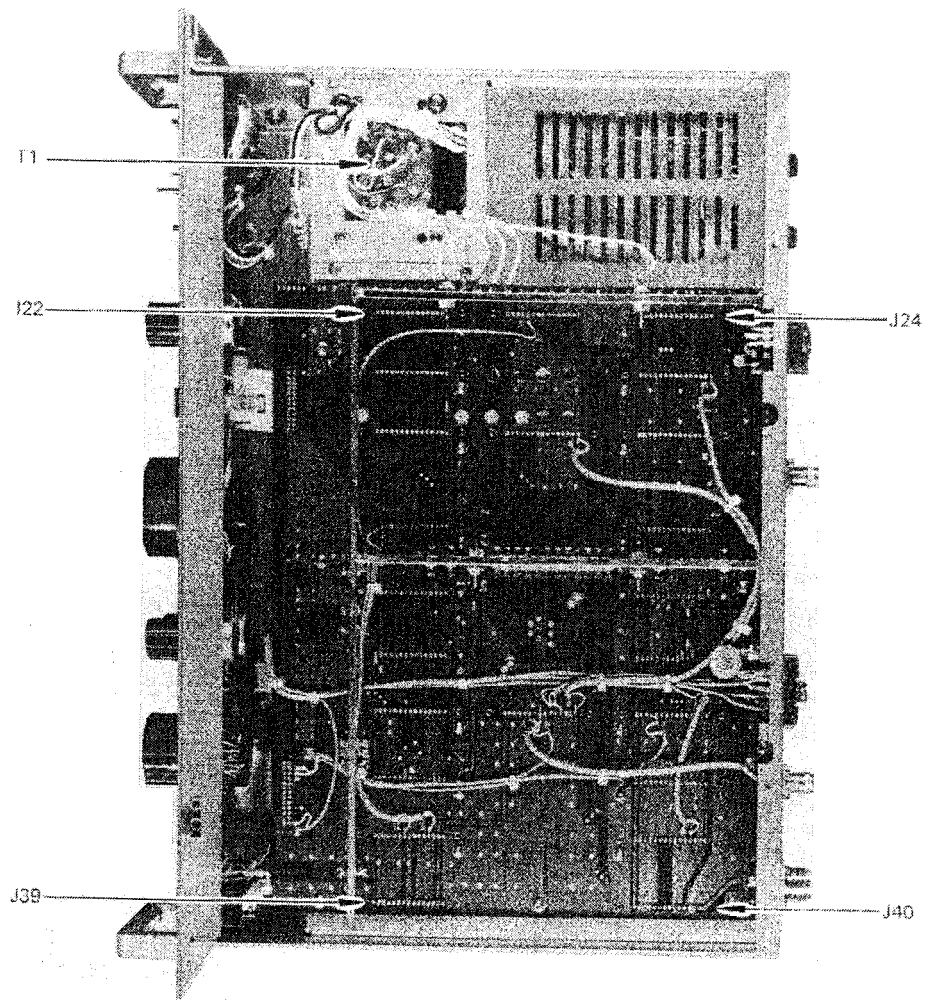

BOTTOM PARTS ARRANGEMENT

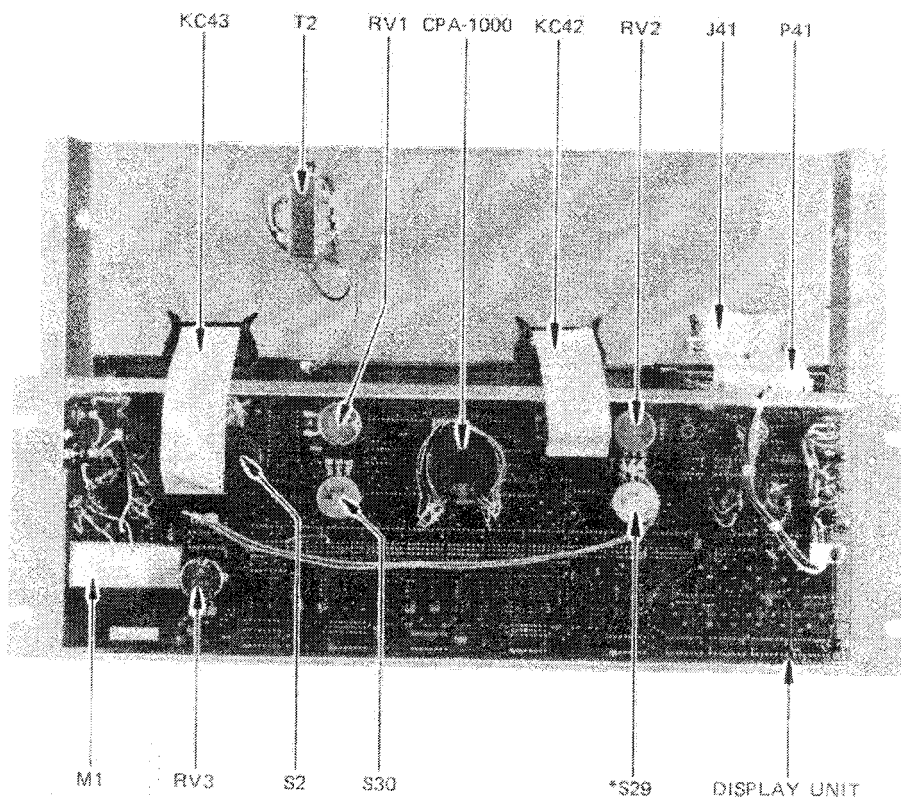

REVERSE SIDE PARTS ARRANGEMENT OF THE FRONT PANEL

(\* only NRD-93)

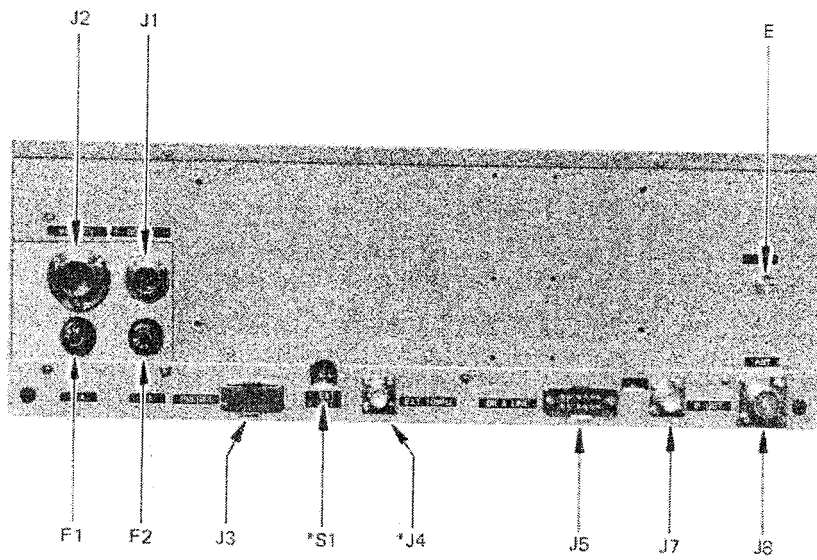

**REAR PARTS ARRANGEMENT**

(\* only NRD-93)

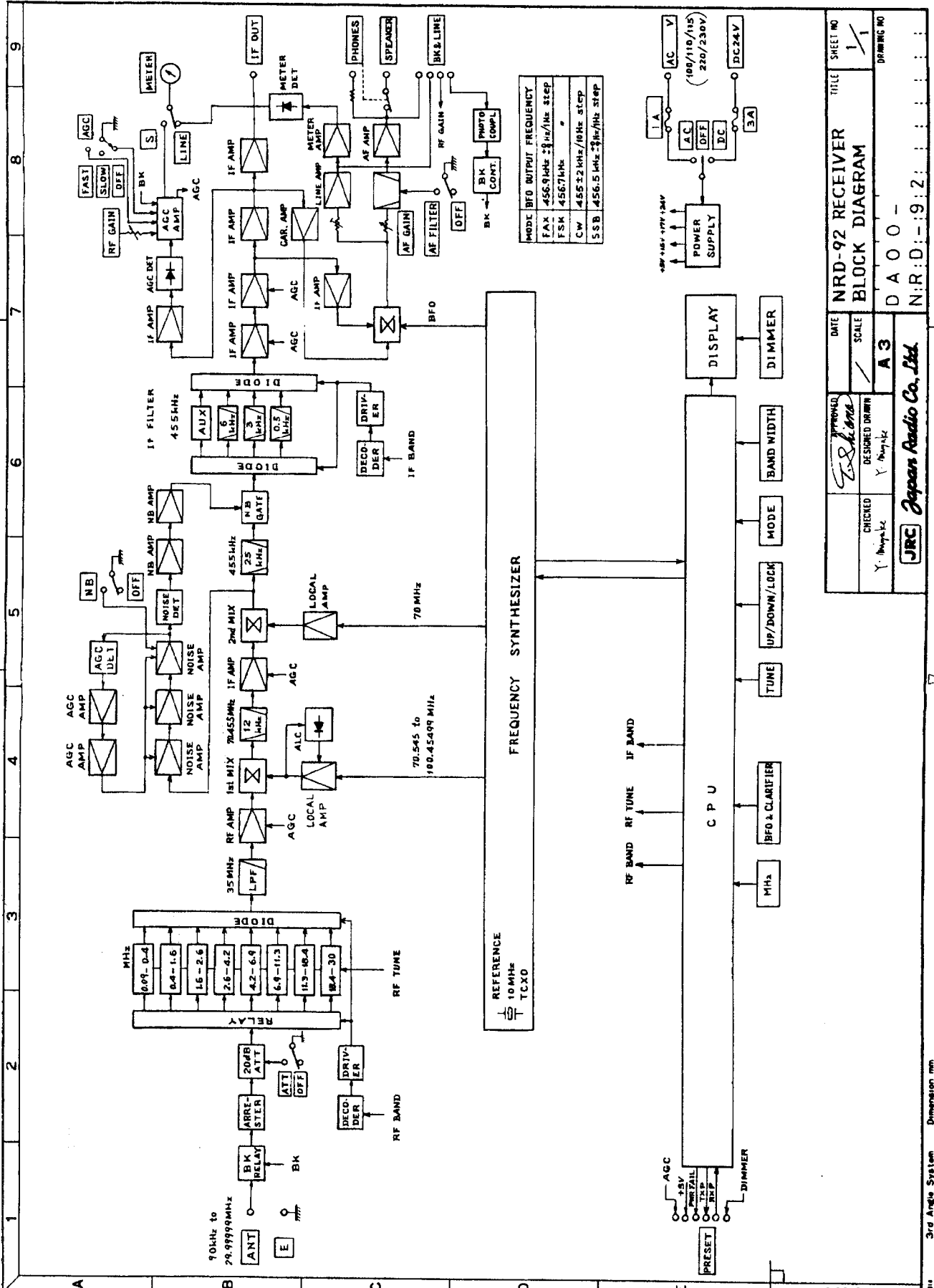

MODE	BFO OUTPUT FREQUENCY
FAX	456.9 kHz ± 2 Hz/Hz step
FSK	456.7 kHz
CW	455 ± 2 kHz / 10 Hz step
SSB	456.5 kHz ± 2 Hz/Hz step

ARRANGE NO	31
REVISIONS	
DATE	10/10/15
SCALE	A3
CHECKED	Y. Nishizaki
DESIGNED DRAWN	Y. Nishizaki
TITLE	NRD-92 RECEIVER BLOCK DIAGRAM
SHEET NO	1/1
DRAWING NO	DA000
N.R.D. - 92	
JIRC Japan Radio Co., Ltd.	

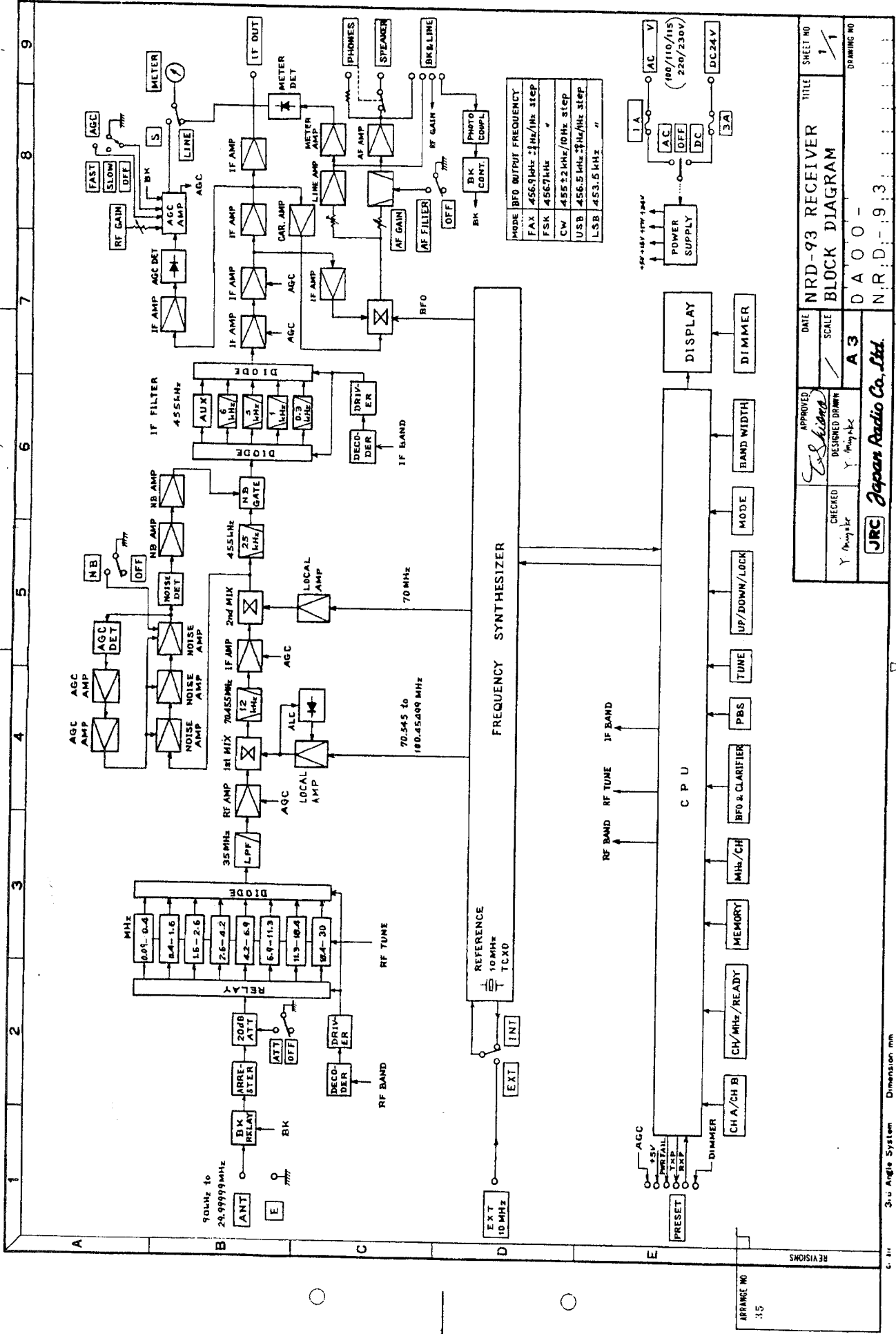

DATE: \_\_\_\_\_ TITLE: NRD-93 RECEIVER SHEET NO: 1/1

SCALE: \_\_\_\_\_ BLOCK DIAGRAM DRAWING NO: D A 0 0 -

APPROVED: *S. Nakano* A 3 N.R.D.-93.3

CHECKED: Y. Miyake DESIGNED DRAWN: Y. Miyake

JRC Japan Radio Co., Ltd.

REVISIONS

ARRANGE NO. 35

3.0 Angle System Dimension mm



8 7 6 5 4 3 2 1

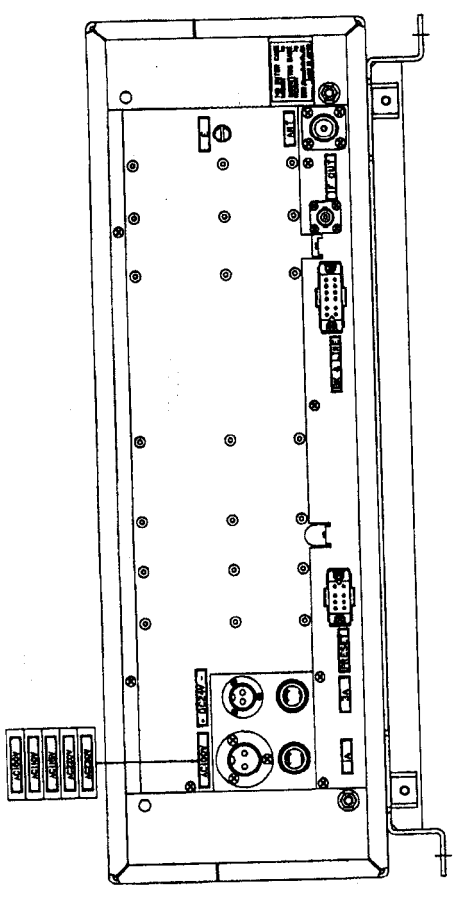

REAR VIEW

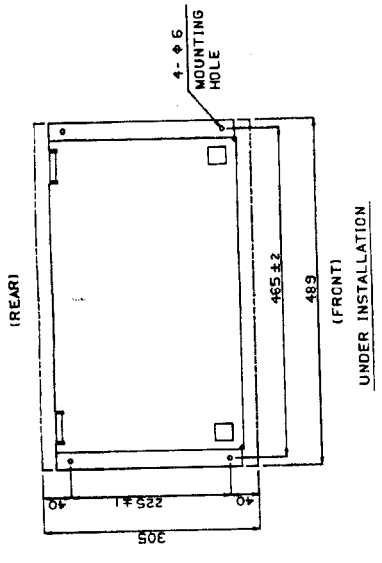

UNDER INSTALLATION

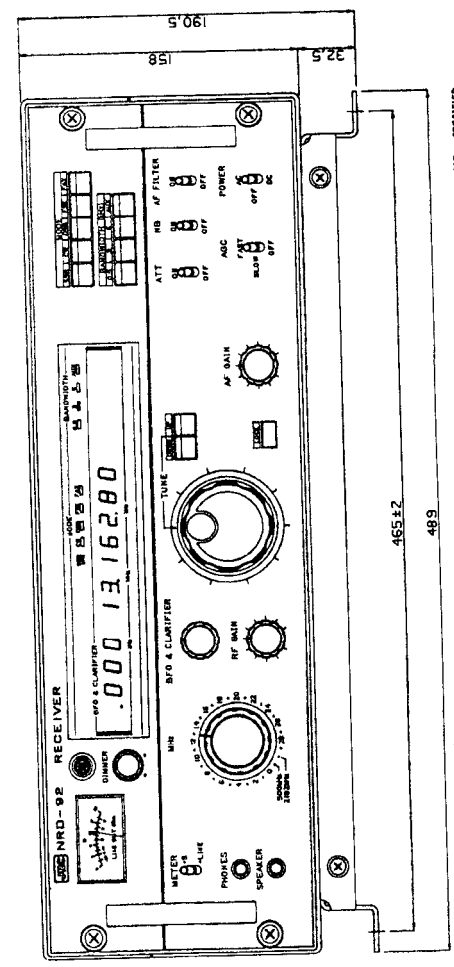

WEIGHT 15 kg

UNLESS OTHERWISE SPECIFIED

DIMENSION	SPECIFIED	TOLERANCE
0 TO 16		± 1
16 TO 50		± 2
50 TO 250		± 4
250 TO 1000		± 8
1000 TO 3000		± 12

APPROVED	JAN 1982	TITLE	NRD-92 RECEIVER	SHEET NO	1
CHECKED	H. Masuda	DESIGNED DIMEN	OUTLINE DRAWING	DRAWING NO	CCNRD6794
	S. Oka	SCALE	1/2		
	M. Tsuda	A 2			
JRC Japan Radio Co., Ltd.					

REVISONS

3.0 Audio System

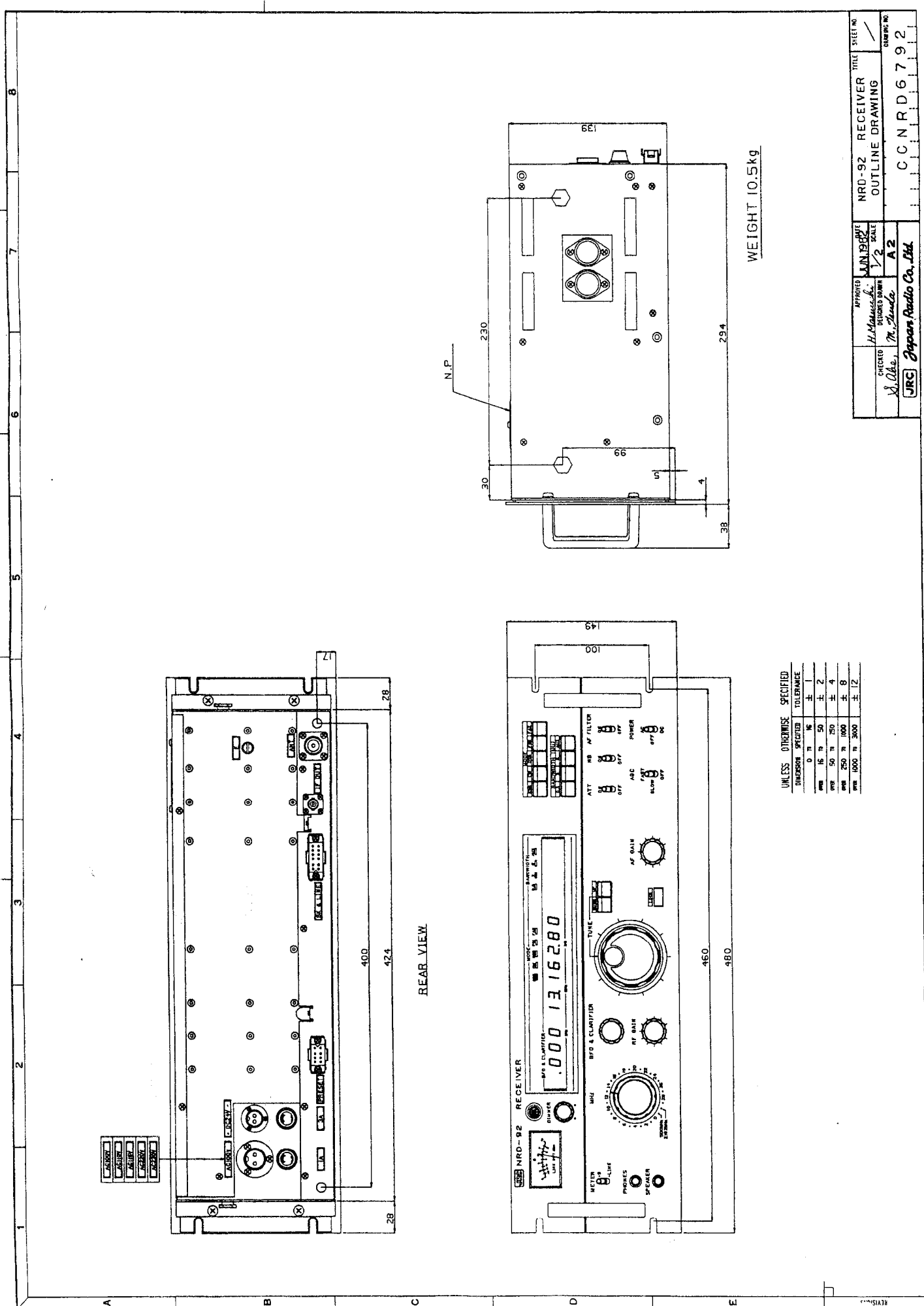

1 2 3 4 5 6 7 8

- ✓ AUDIO
- ✓ VOLUME
- ✓ TONE
- ✓ AF GAIN
- ✓ RF GAIN

REAR VIEW

WEIGHT 10.5kg

UNLESS OTHERWISE SPECIFIED

DIMENSION	SPECIFIED	TOLERANCE
mm	0 to 16	± 1
mm	16 to 50	± 2
mm	50 to 250	± 4
mm	250 to 1000	± 8
mm	1000 to 3000	± 12

APPROVED	JUN 1982	TITLE	NRD-92 RECEIVER	SHEET NO	1
CHECKED	H.M. MURAKAMI	SCALE	OUTLINE DRAWING	DRAWING NO	CCNRD6792
	S. Oba, M. Shindo				
JRC Japan Radio Co., Ltd.					

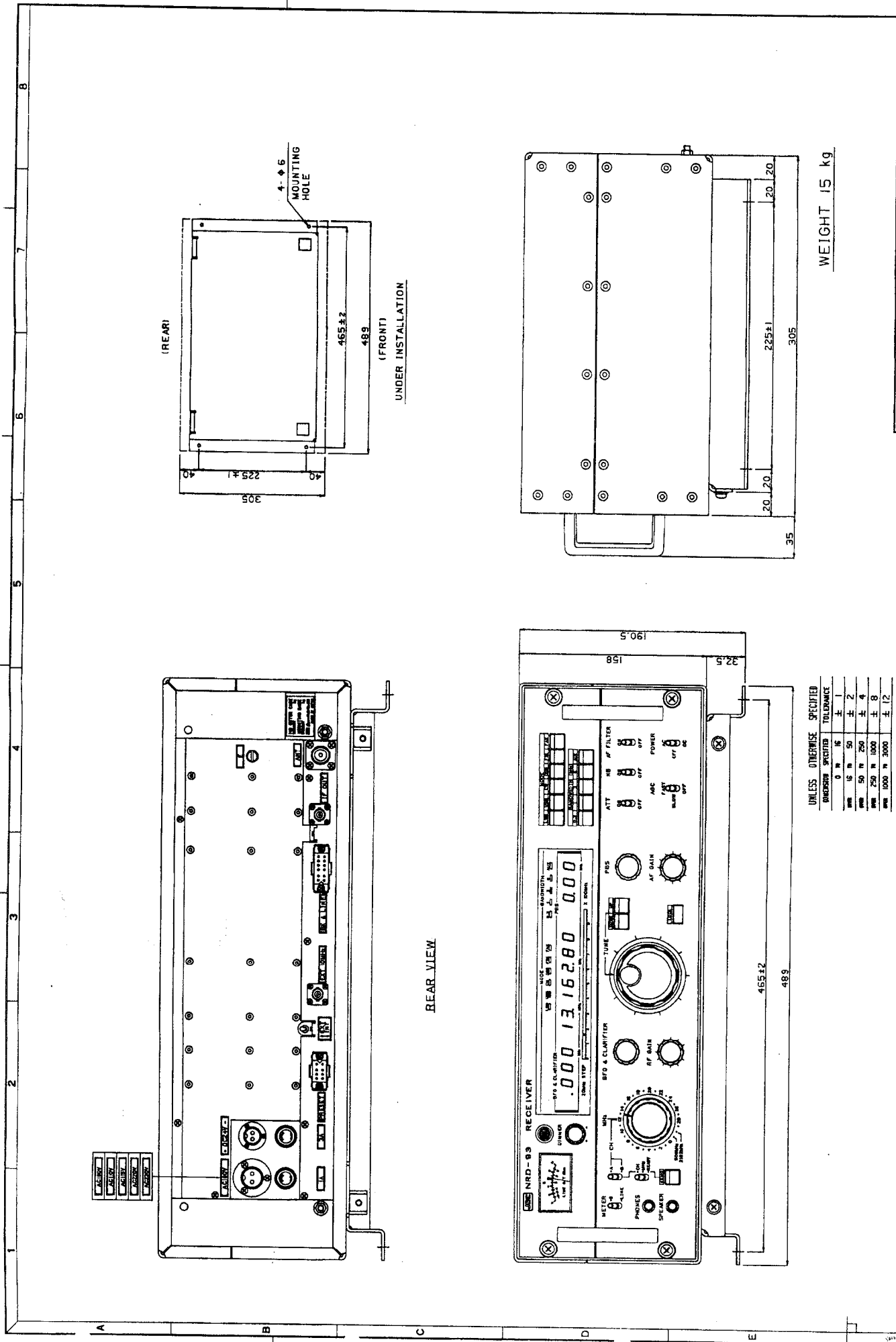

UNLESS OTHERWISE SPECIFIED

DIMENSION	SPECIFIED	TOLERANCE
mm	0 to 16	± 1
mm	16 to 50	± 2
mm	50 to 250	± 4
mm	250 to 1000	± 8
mm	1000 to 3000	± 12

WEIGHT 15 kg

APPROVED	JUN 1962	TITLE	NRD-93 RECEIVER	SHEET NO.	1
CHECKED	S. Ueda	DISK/DRAWN	OUTLINE DRAWING	DRAWING NO.	CCNRD6800
H. Matsuoka JUN 1962 1/2 SOKES		A2 JRC Japan Radio Co., Ltd.			

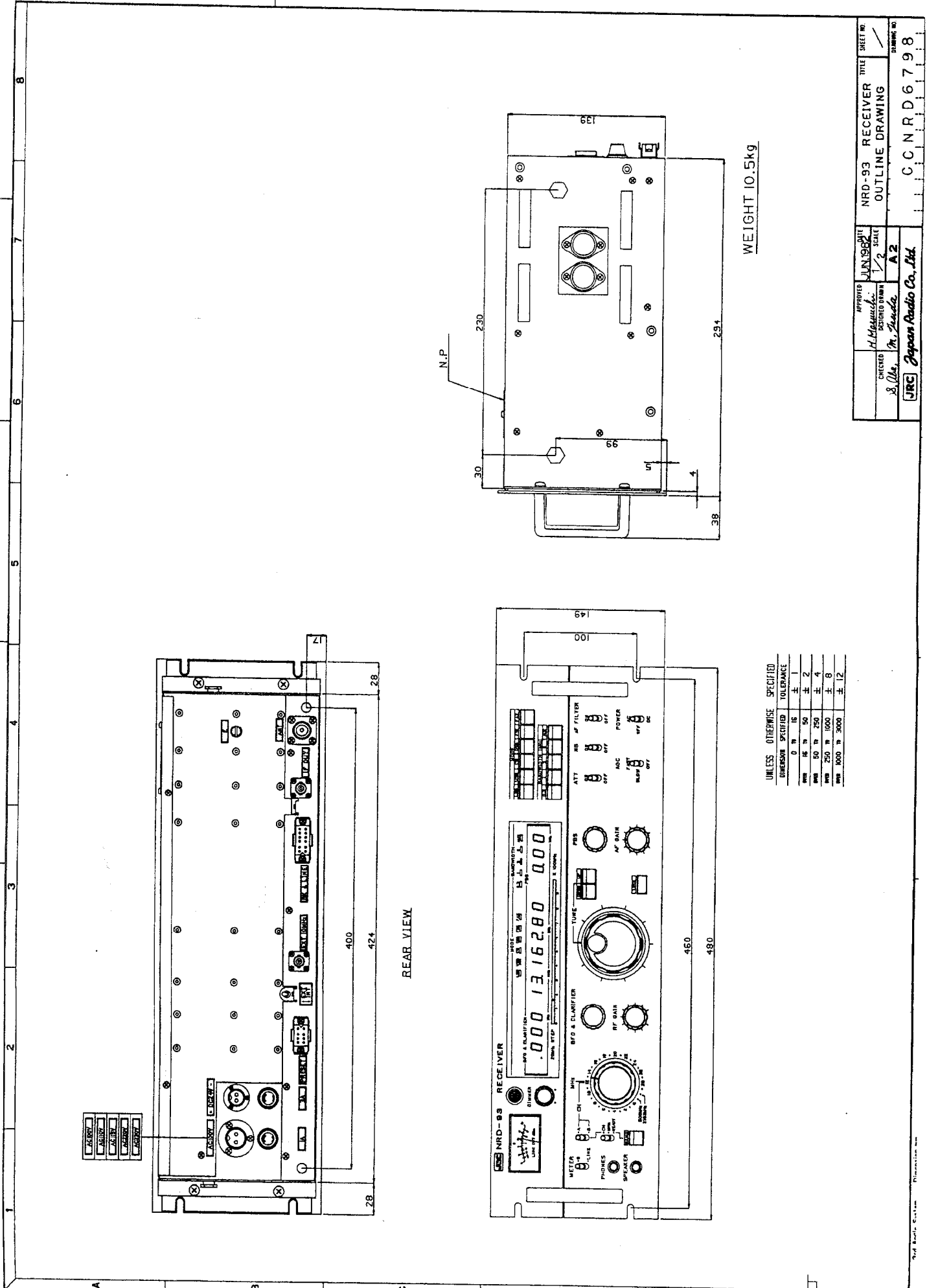

REAR VIEW

WEIGHT 10.5kg

UNLESS OTHERWISE SPECIFIED

DIMENSION	SPECIFIED	TOLERANCE
0 TO 16	±	1
16 TO 50	±	2
50 TO 250	±	4
250 TO 1000	±	6
1000 TO 3000	±	12

APPROVED	JUN 1982	DATE	NRD-93 RECEIVER	TITLE	SHEET NO.
CHECKED	H. Miyazaki	DESIGNED BY	OUTLINE DRAWING		
	S. Ueda				
	M. Saito	SCALE			
JRC	Japan Radio Co., Ltd.				DRAWING NO.
					C N R D 6 7 9 8

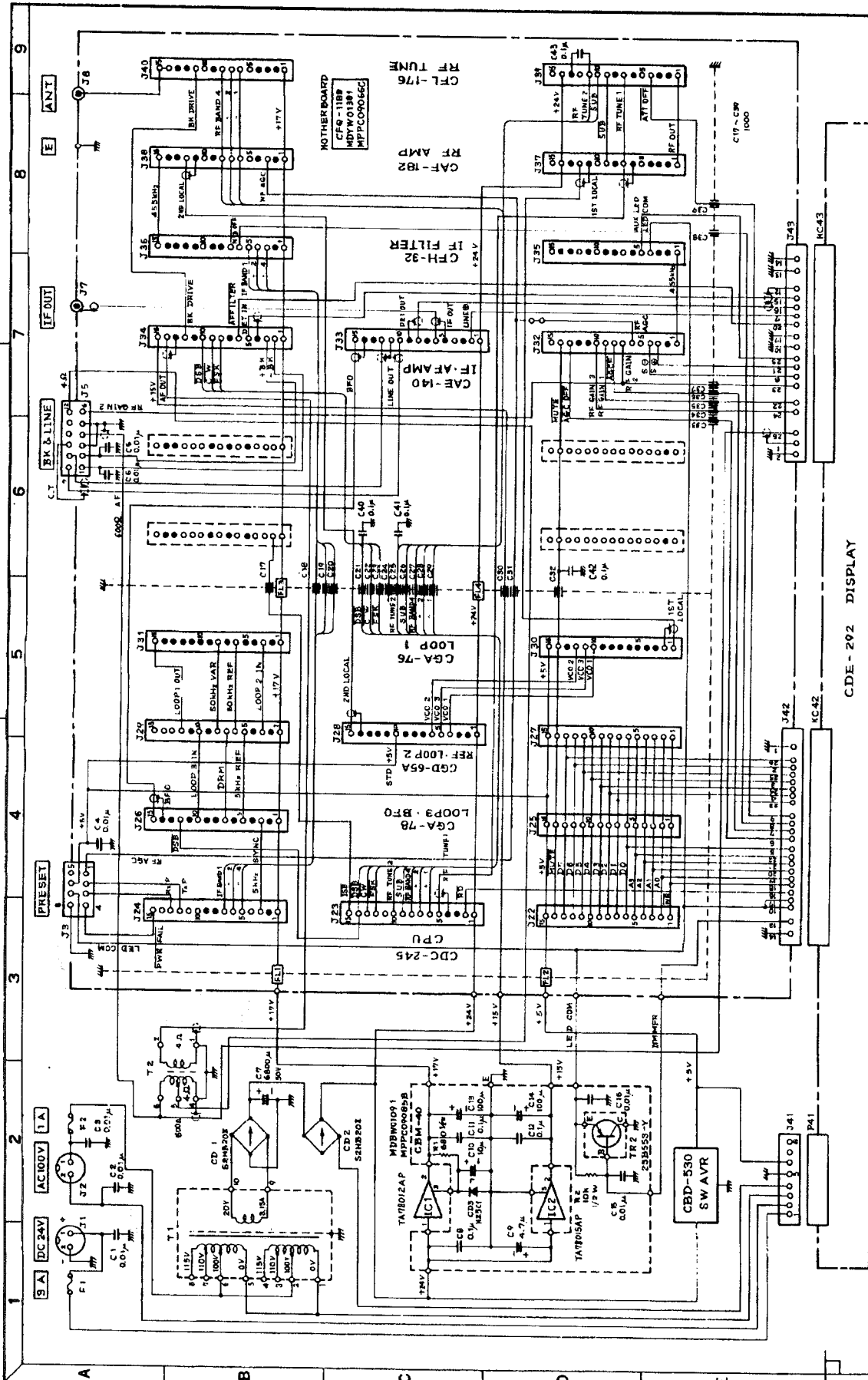

DATE	TITLE	SHEET NO
SCALE	NRD-92 MAIN CHASSIS	1/11
APPROVED	DESIGNED DRAWN	DRAWING NO
CHECKED	A 3	DD000 -
Y. Angyale		N.R.D.-92

APPROVED	DESIGNED DRAWN
CHECKED	A 3
Y. Angyale	
JRC Japan Radio Co. Ltd.	

CDE - 202 DISPLAY

NOTES (1) UNLESS OTHERWISE INDICATED RESISTANCES ARE IN OHMS  
AND CAPACITANCES ARE IN MICRO-MICRO FARADS.  
(2) \* VALUES ARE SELECTED IN MANUFACTURE.

3rd Angle System Dimension mm

ARRANGEMENT NO	REVISIONS
40	

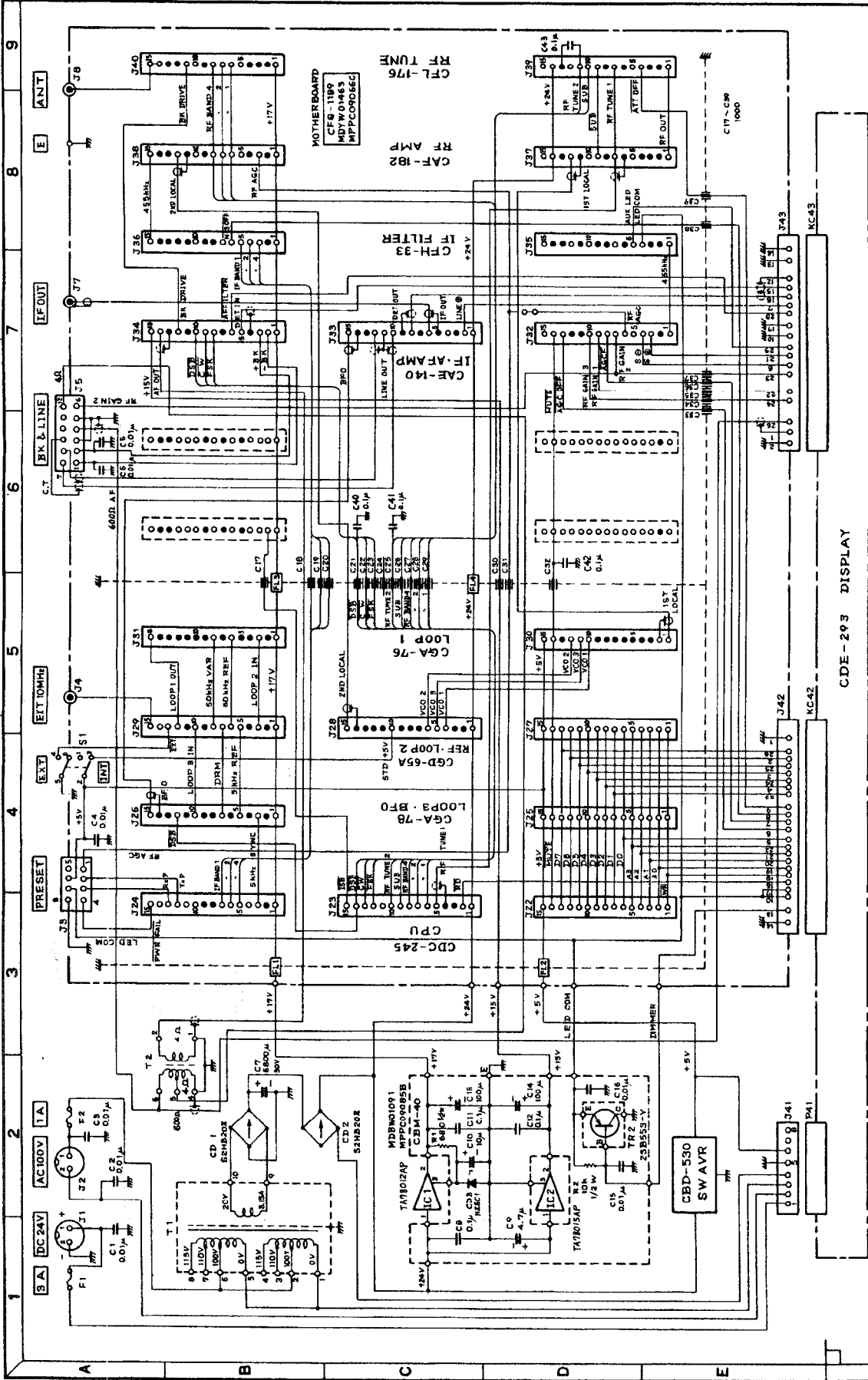

ARRANGE NO. 41	REVISEMENTS	APPROVED <i>[Signature]</i>	DATE	TITLE NRD-93 MAIN CHASSIS CONNECTION DIAGRAM	SHEET NO 1/11
		CHECKED Y. Miyake	DESIGNED Y. Kamikawa	SCALE A3	DRAWING NO
		JRC Japan Radio Co., Ltd.			DDOO - N.R.D. - 93

CDE-293 DISPLAY

NOTES (1) UNLESS OTHERWISE INDICATED RESISTANCES ARE IN OHMS  
AND CAPACITANCES ARE IN MICRO-MICRO FARADS.  
(2) \* VALUES ARE SELECTED IN MANUFACTURE.

Dimension mm

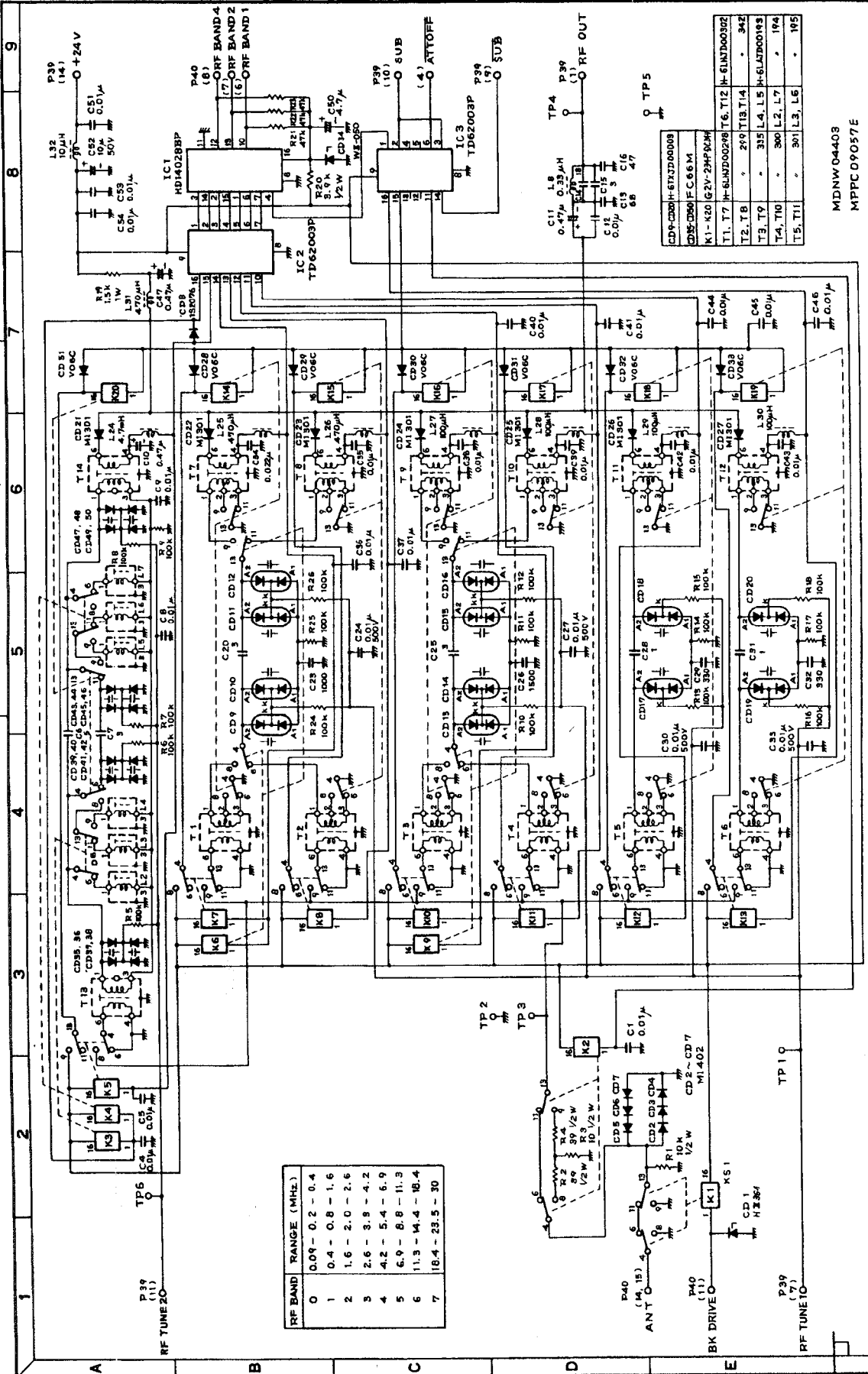

DATE: \_\_\_\_\_ TITLE: CFL-176 RF TUNE CONNECTION DIAGRAM SHEET NO: 2/11

CHECKED: Y. Miyake DESIGNED DRAWN: T. Ogawa SCALE: A3

APPROVED: *[Signature]*

REVISIONS: \_\_\_\_\_

ARRANGE NO: 42

NOTES (1) UNLESS OTHERWISE INDICATED RESISTANCES ARE IN OHMS AND CAPACITANCES ARE IN MICRO-MICRO FARADS. (2) \* VALUES ARE SELECTED IN MANUFACTURE.

3rd Angle System Dimension mm

JRC Japan Radio Co. Ltd.

N.R.D. 92/93

MDNW 04403 MPPC 09057E

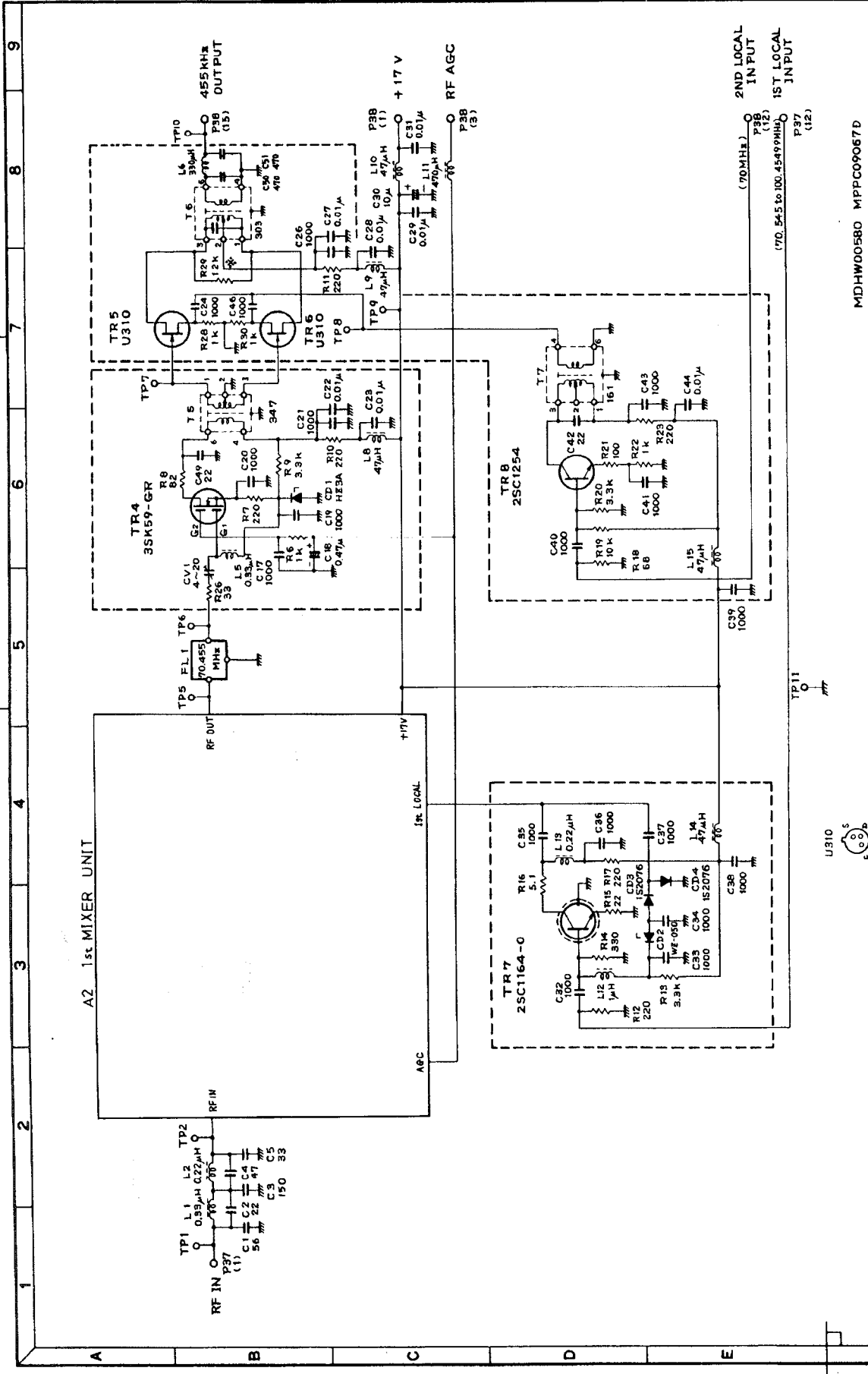

A2 1st MIXER UNIT

U310

BOTTOM VIEW

NOTES (1) UNLESS OTHERWISE INDICATED RESISTANCES ARE IN OHMS AND CAPACITANCES ARE IN MICRO-MICRO FARADS. (2) \* VALUES ARE SELECTED IN MANUFACTURE.

ARRANGE NO. 43

REVISIONS

Y. Nagaoka	Y. Kamekura	DATE	SCALE	TITLE	SHEET NO.
			A 3	CAF-182 RF AMP CONNECTION DIAGRAM	3 / 11
Japan Radio Co., Ltd.		N.R.D. 92 / 93			

MDHW00580 MPPC09067D



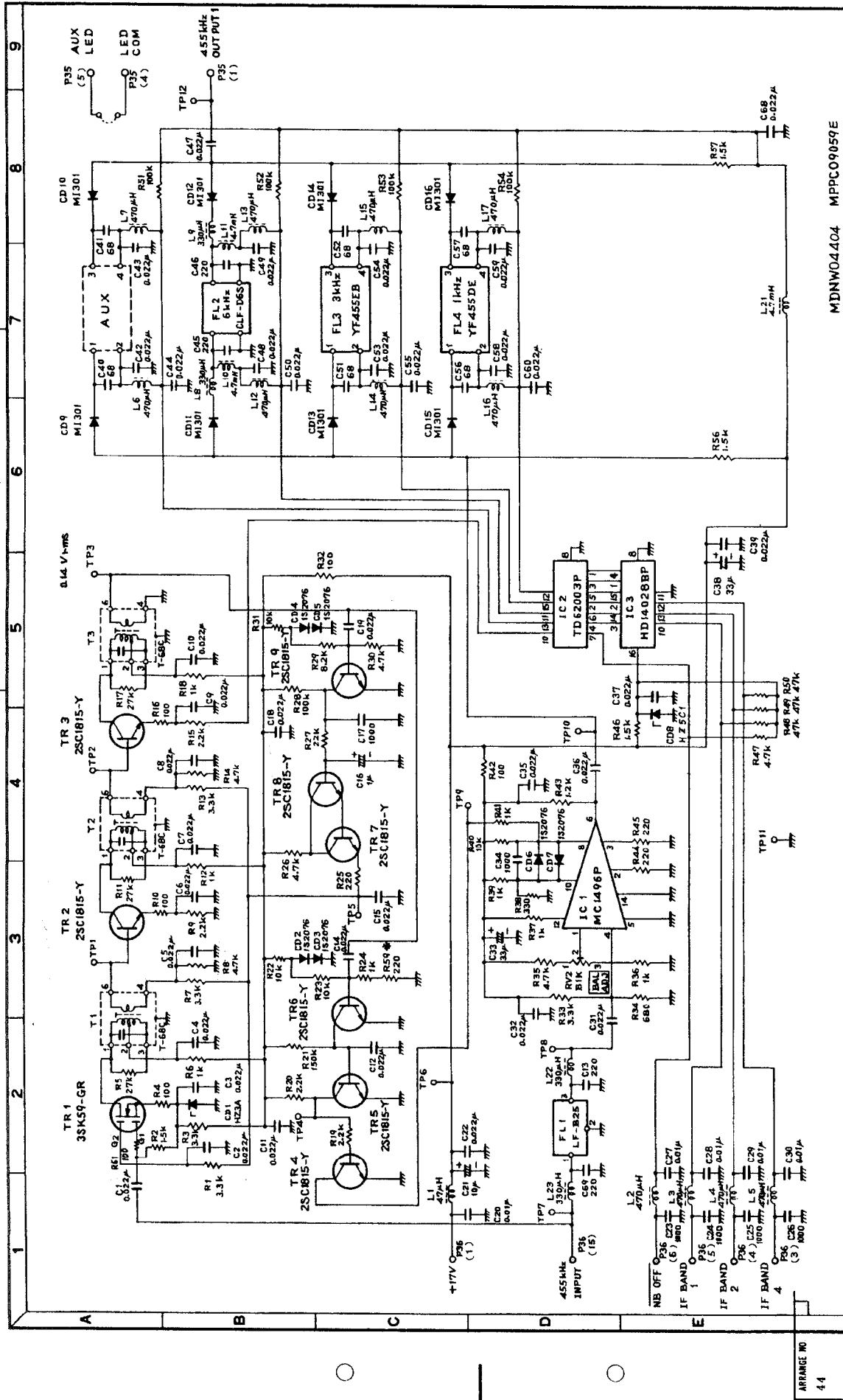

ARRANGE NO 4.4	REVISIONS	DATE	TITLE	SHEET NO
			CFH-32 IF FILTER CONNECTION DIAGRAM	4/11
		APPROVED	SCALE	
		DESIGNED DRAWN	A3	
		CHECKED		
		JRC Japan Radio Co., Ltd.		
		MDNW0404 MPPC09059E		
		N.R.D.-9.2		
		D D O O -		
		DRAWING NO		

NOTES (1) UNLESS OTHERWISE INDICATED RESISTANCES ARE IN OHMS AND CAPACITANCES ARE IN MICRO-MICRO FARADS.  
 (2) \* VALUES ARE SELECTED IN MANUFACTURE.

3rd Angle System Dimension mm

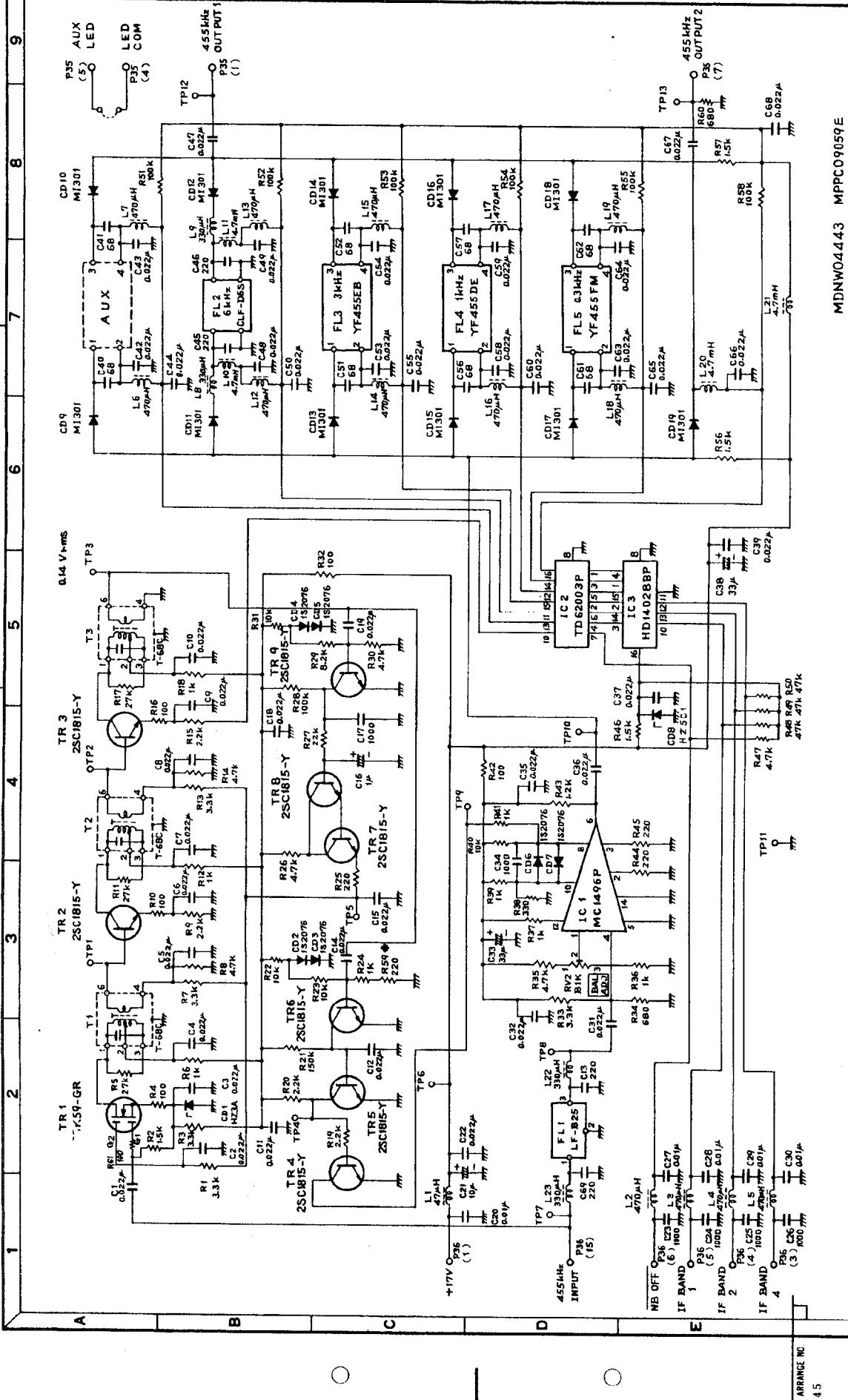

ARRANGE NO	45
REVISIONS	
DATE	
SCALE	A3
CHECKED	Y. Miyabe
DESIGNED DRAWN	Y. Kamikawa
APPROVED	<i>[Signature]</i>
TITLE	CFH-33 IF FILTER CONNECTION DIAGRAM
SHEET NO	4/11
DRAWING NO	DD000-
N.R.D.	9.3
MDNWO4443	MPPC09059E

NOTES (1) UNLESS OTHERWISE INDICATED RESISTANCES ARE IN OHMS AND CAPACITANCES ARE IN MICRO-MICRO FARADS.  
 (2) \* VALUES ARE SELECTED IN MANUFACTURE.

3rd Angle System Dimension mm

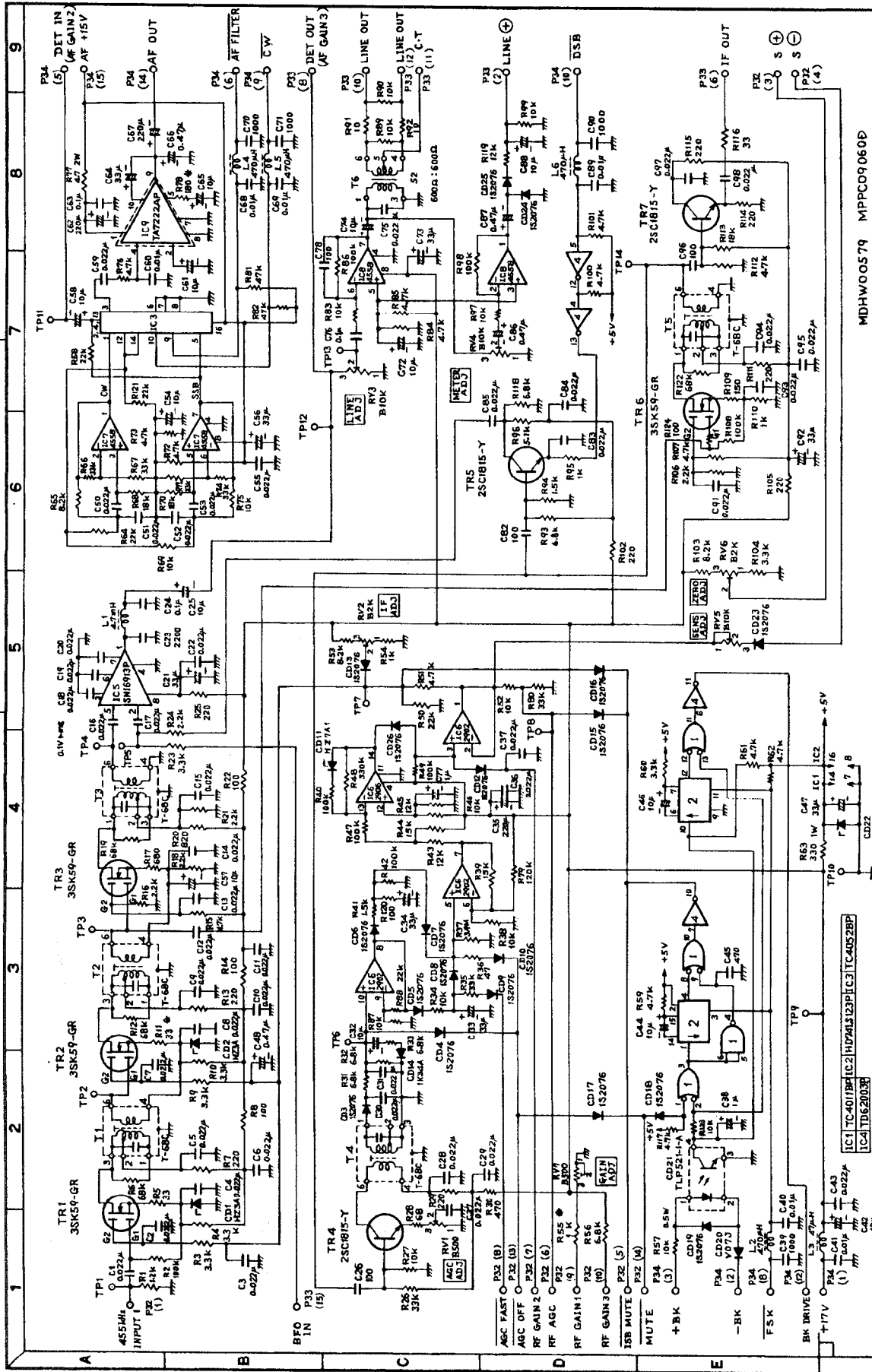

ARRANGE NO 46	REVISIONS	DATE	SCALE	TITLE SHEET NO CAE-140 IF-AF AMP CONNECTION DIAGRAM 5/11
		Y. Nishida	A 3	MDHWO0579 MPPC09060D
		Y. Nishida	DESIGNED DRAWN	DDO00
		JRC Japan Radio Co., Ltd.		N.R.D.-92/93

NOTES (1) UNLESS OTHERWISE INDICATED RESISTANCES ARE IN OHMS AND CAPACITANCES ARE IN MICRO-MICRO FARADS.  
(2) \* VALUES ARE SELECTED IN MANUFACTURE.

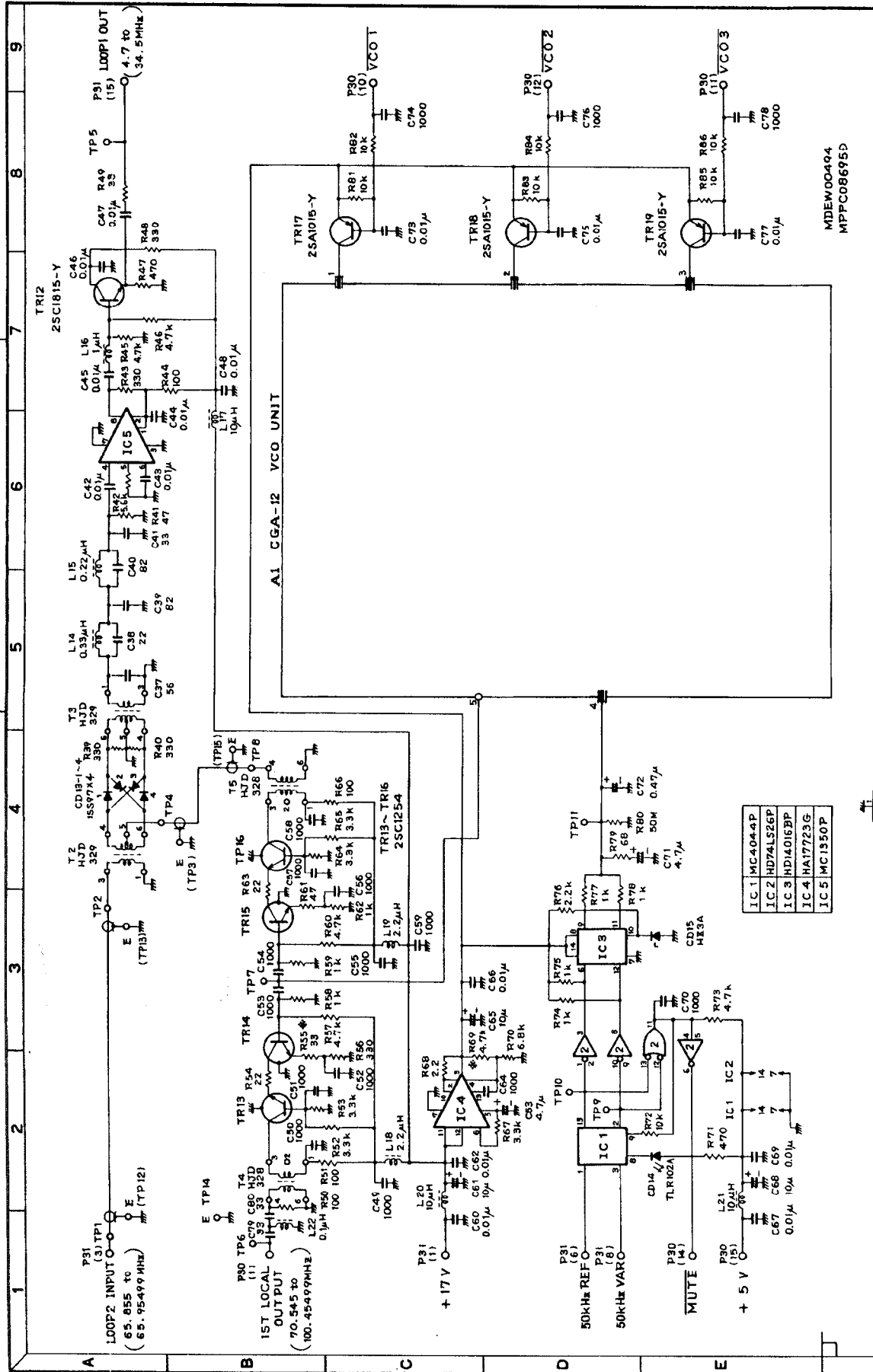

ARRANGE NO. 47	REVISIONS	DATE	TITLE	SHEET NO
			CGA-76 LOOP 1 CONNECTION DIAGRAM	6 / 11
	CHECKED Y. Nishiyama	SCALE		DRAWING NO
	DESIGNED DRAWN Y. Nishiyama	A3		DD00-
				N.R.D.: 9.2 / 9.3

APPROVED  
*[Signature]*  
DESIGNED DRAWN  
Y. Nishiyama

JRC Japan Radio Co., Ltd.

MD5W00494  
MPPC08695D

NOTES (1) UNLESS OTHERWISE INDICATED RESISTANCES ARE IN OHMS AND CAPACITANCES ARE IN MICRO-MICRO FARADS.  
(2) \* VALUES ARE SELECTED IN MANUFACTURE.

3rd Angle System Dimension mm

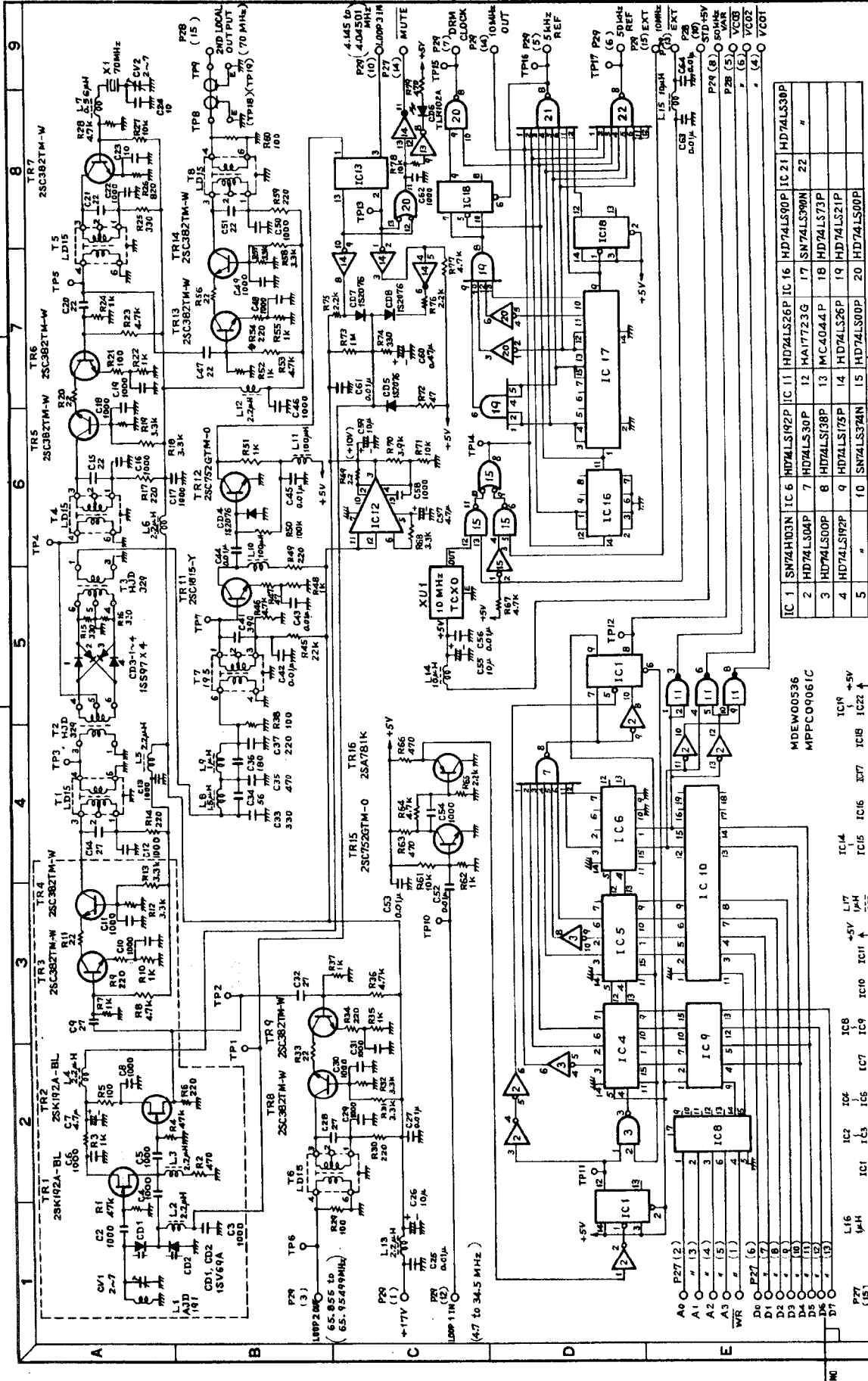

ARRANGE NO	REVISIONS	DATE	SCALE	DESIGNED DRAWN	CHECKED	APPROVED	TITLE	SHEET NO
18				Y. Nishibe	Y. Nishibe	Y. Nishibe	CGD-65A REF. LOOP 2 CONNECTION DIAGRAM	7/1

IC 1	IC 2	IC 3	IC 4	IC 5	IC 6	IC 7	IC 8	IC 9	IC 10	IC 11	IC 12	IC 13	IC 14	IC 15	IC 16	IC 17	IC 18	IC 19	IC 20	IC 21
SN74ALS00P	SN74ALS00P	SN74ALS00P	SN74ALS00P	SN74ALS00P	SN74ALS00P	SN74ALS00P	SN74ALS00P	SN74ALS00P	SN74ALS00P	SN74ALS00P	SN74ALS00P	SN74ALS00P	SN74ALS00P	SN74ALS00P	SN74ALS00P	SN74ALS00P	SN74ALS00P	SN74ALS00P	SN74ALS00P	SN74ALS00P

IC 1	IC 2	IC 3	IC 4	IC 5	IC 6	IC 7	IC 8	IC 9	IC 10	IC 11	IC 12	IC 13	IC 14	IC 15	IC 16	IC 17	IC 18	IC 19	IC 20	IC 21
SN74ALS00P	SN74ALS00P	SN74ALS00P	SN74ALS00P	SN74ALS00P	SN74ALS00P	SN74ALS00P	SN74ALS00P	SN74ALS00P	SN74ALS00P	SN74ALS00P	SN74ALS00P	SN74ALS00P	SN74ALS00P	SN74ALS00P	SN74ALS00P	SN74ALS00P	SN74ALS00P	SN74ALS00P	SN74ALS00P	SN74ALS00P

ARRANGE NO: 18

REVISIONS:

DATE: / /

SCALE: A3

DESIGNED DRAWN: Y. Nishibe

CHECKED: Y. Nishibe

APPROVED: Y. Nishibe

TITLE: CGD-65A REF. LOOP 2 CONNECTION DIAGRAM

SHEET NO: 7/1

Drawing No: D D O O - N.R.D. - 9 2 / 9 3

NOTES (1) UNLESS OTHERWISE INDICATED RESISTANCES ARE IN OHMS  
 (2) \* AND CAPACITANCES ARE IN MICRO-MICRO FARADS.  
 (3) \* VALUES ARE SELECTED IN MANUFACTURE.

3rd Angle System Dimension mm

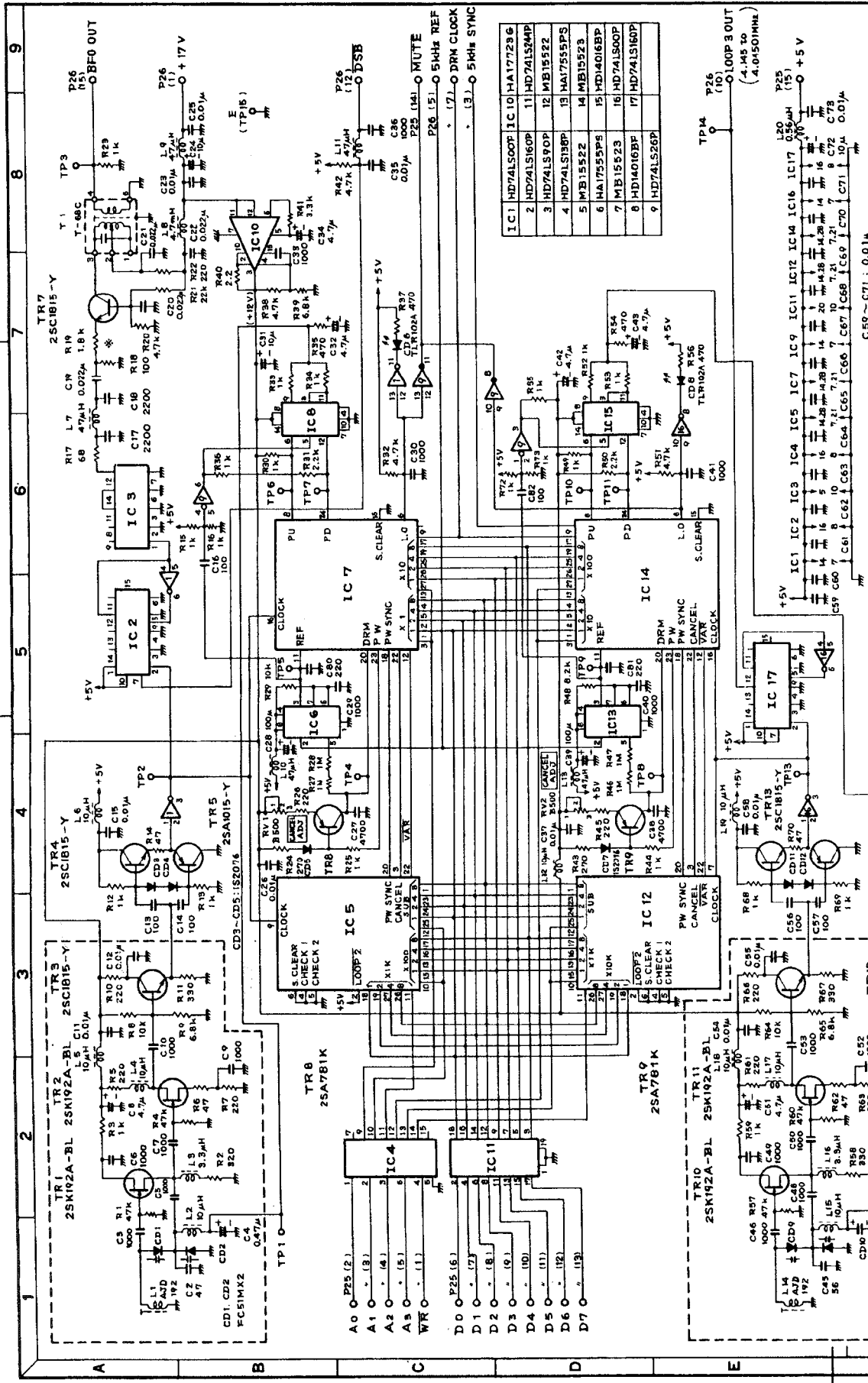

IC 1	HD74LS00P	IC 10	HA17723G
2	HD74LS160P	11	HD74LS94P
3	HD74LS90P	12	MB15522
4	HD74LS138P	13	HA17555PS
5	MB15522	14	MB15523
6	HA17555PS	15	HD14016BP
7	MB15523	16	HD74LS00P
8	HD14016BP	17	HD74LS160P
9	HD74LS26P		

DATE	CGA-78	LOOP 3	BFO	TITLE	SHEET NO
SCALE				CONNECTION DIAGRAM	8 / 11
APPROVED	<i>[Signature]</i>				
CHECKED	Y. Miyake				
DESIGNED DRAWN	Y. Miyake				
A 3		D D O O		N.R.D. 92/93	
JRC Japan Radio Co., Ltd.					

MDEWOOD587  
MPPC04062C

NOTES (1) UNLESS OTHERWISE INDICATED RESISTANCES ARE IN OHMS  
AND CAPACITANCES ARE IN MICRO-MICRO FARADS.  
(2) \* VALUES ARE SELECTED IN MANUFACTURE.

3rd Angle System Dimension mm

ARRANGE NO  
49

REVISIONS

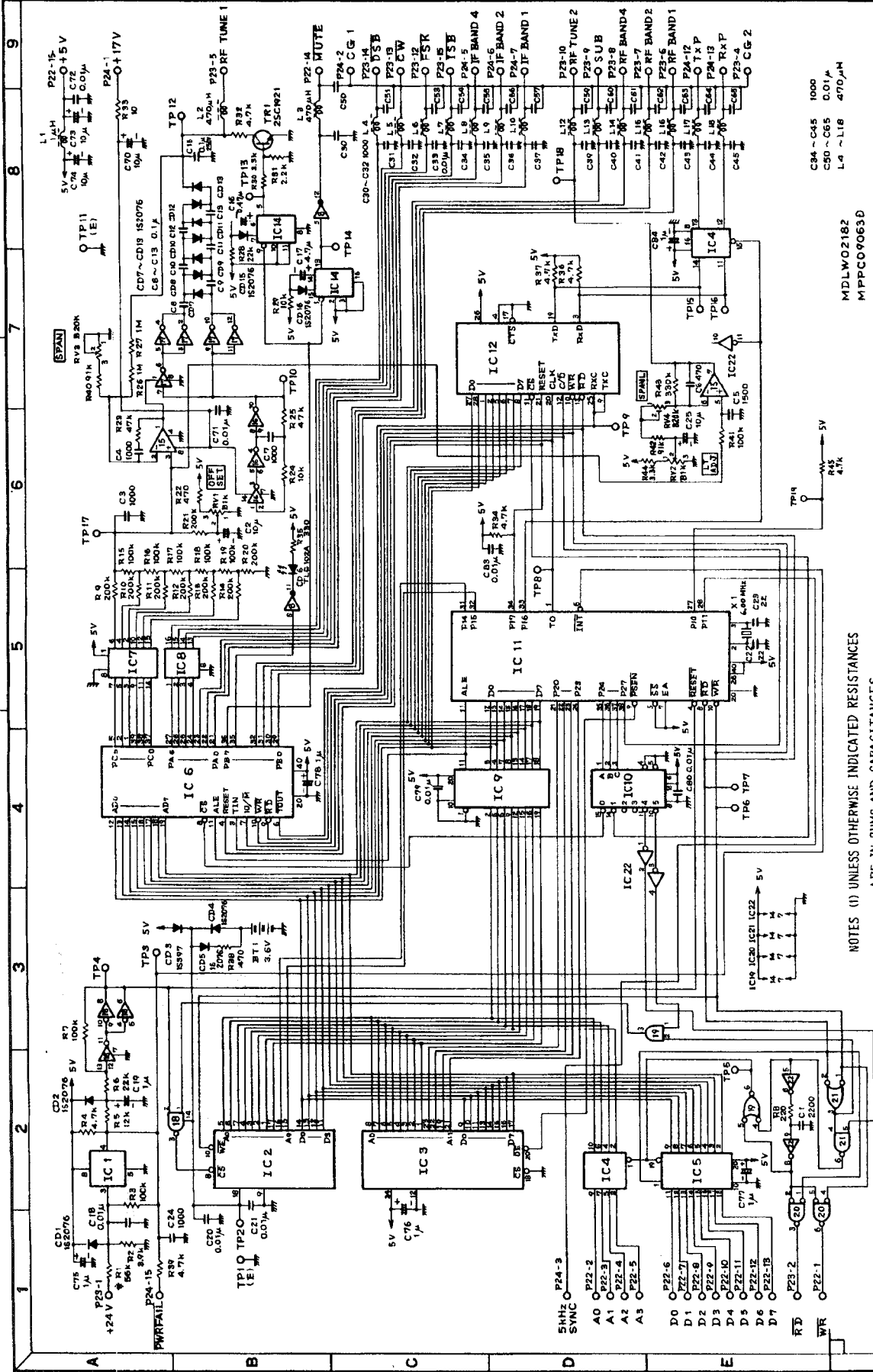

ARRANGE NO.	50	DATE	9/11	TITLE	CDC-245 CPU CONNECTION DIAGRAM	SHEET NO.	9/11
CHECKED	Y. Miyake	DESIGNED DRAWN	A3	APPROVED	J. Ogawa	DRAWING NO.	DDO00-
				<b>JRC</b> Japan Radio Co., Ltd. N.R.D.: 9:2/9:3			

NOTES (1) UNLESS OTHERWISE INDICATED RESISTANCES ARE IN OHMS AND CAPACITANCES ARE IN MICRO-MICRO FARADS. (2) \* VALUES ARE SELECTED IN MANUFACTURE.

REVISIONS	IC1	IC2	IC3	IC4	IC5	IC6	IC7	IC8	IC9	IC10	IC11	IC12
	ICL811CPA	IC71 TC4049BP	IC4 SN74LS22N	IC5 HA179G-4PS	IC6 HD74LS00P	IC7 TC4011BP	IC8 HD74LS04P	IC9 HD74LS24N	IC10 MDD8251AC	IC11 MDD8251AC	IC12 TC4049BP	

MDLW02182  
MPPCO9063D

ARRANGE NO. 50

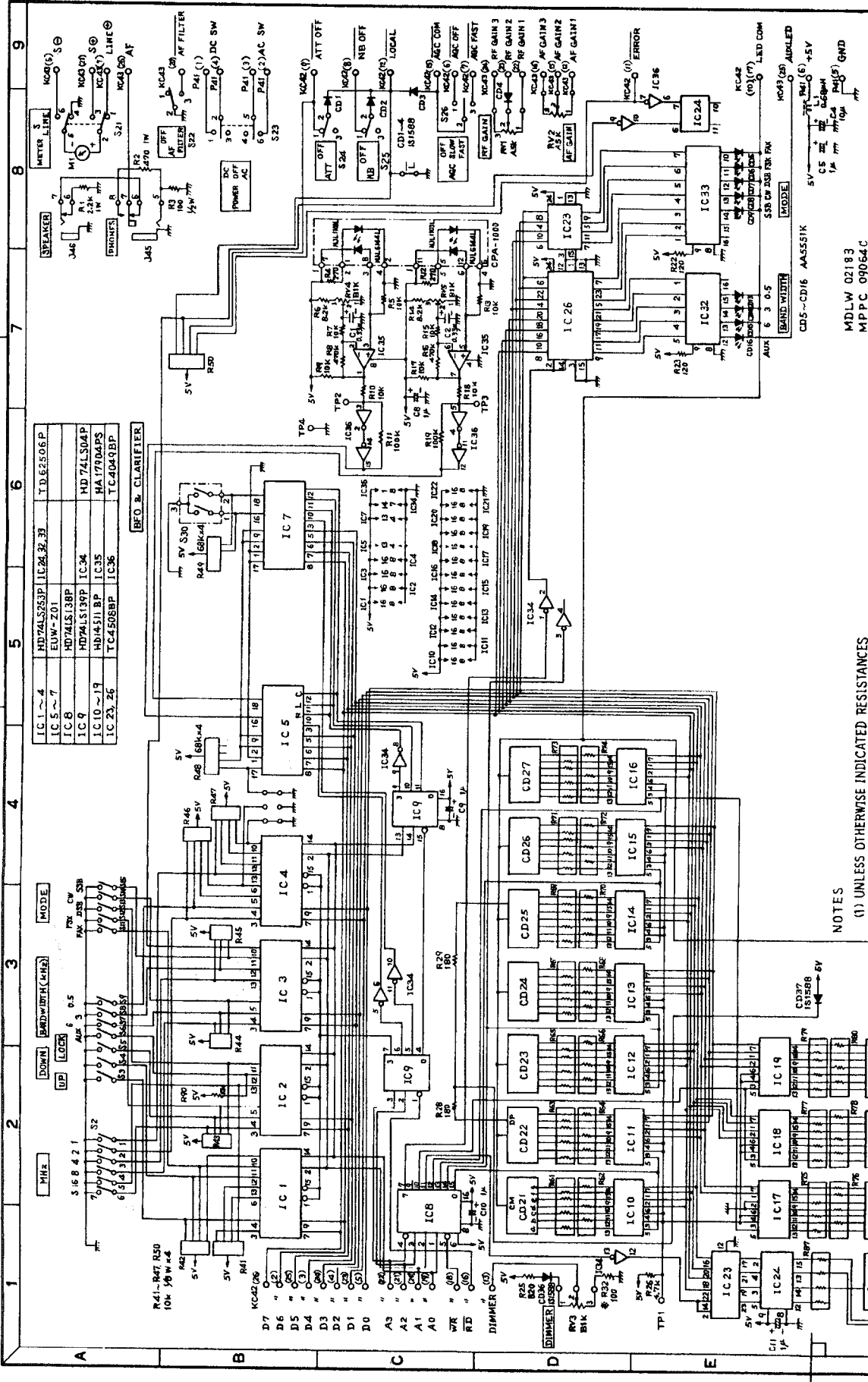

DATE	TITLE	SHEET NO.
SCALE	CONNECTION DIAGRAM	10/11
APPROVED	DRAWING NO.	
DESIGNED DRAWN	D D O O -	
CHECKED	N.R.D.: 9:2	
JRC	Japan Radio Co., Ltd.	
MDLW 02183	MPPC 09054C	

NOTES

(1) UNLESS OTHERWISE INDICATED RESISTANCES ARE IN OHMS AND CAPACITANCES ARE IN MICRO MICRO FARADS.

(2) \*VALUES ARE SELECTED IN MANUFACTURE.

ARRANGE NO. 51

REVISIONS

CD21 - CD27 SEL911  
 CD28 - CD31 SEL511  
 R61 ~ R87 100 1/8Wx4

BFO & CLARIFIER

3rd Angle System Dimension mm



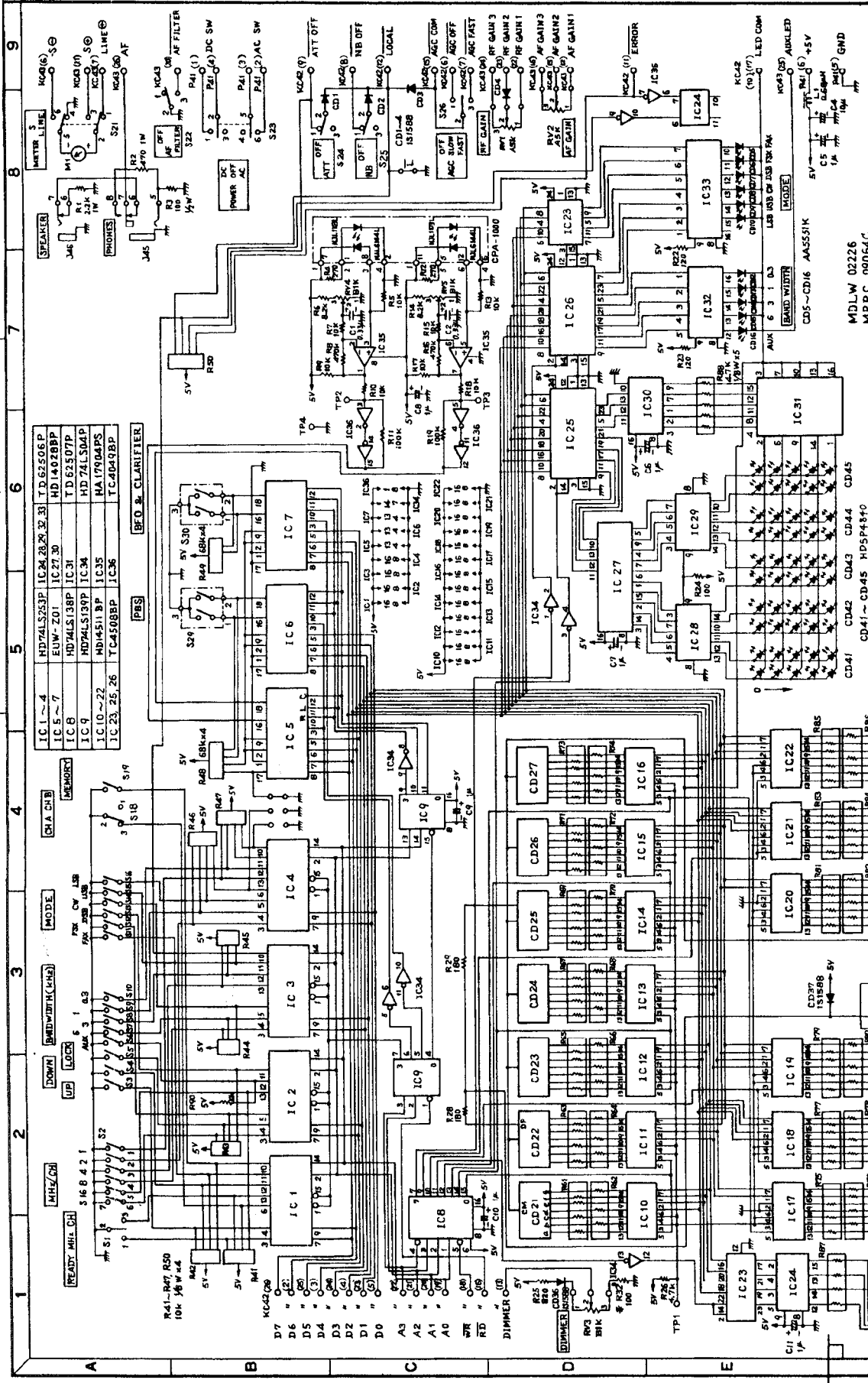

IC 1 ~ 4	HD74LS253P	IC 24, 28, 29, 30, 33	T D 62506P
IC 5 ~ 7	EUV Z01	IC 27, 30	HD14028BP
IC 8	HD74LS138P	IC 31	T D 62507P
IC 9	HD74LS139P	IC 34	HD74LS04P
IC 10 ~ 22	HD4511 BP	IC 35	MA17904PS
IC 23, 25, 26	TC4508BP	IC 36	TC4049BP

IC 1 ~ 4	HD74LS253P	IC 24, 28, 29, 30, 33	T D 62506P
IC 5 ~ 7	EUV Z01	IC 27, 30	HD14028BP
IC 8	HD74LS138P	IC 31	T D 62507P
IC 9	HD74LS139P	IC 34	HD74LS04P
IC 10 ~ 22	HD4511 BP	IC 35	MA17904PS
IC 23, 25, 26	TC4508BP	IC 36	TC4049BP

DATE: \_\_\_\_\_ TITLE: CDE-293 DISPLAY CONNECTION DIAGRAM SHEET NO. 10 / 11

SCALE: \_\_\_\_\_

APPROVED: *[Signature]* DESIGNED: *[Signature]* CHECKED: *[Signature]* DRAWN: *[Signature]*

MDLW 02226 MPPC 09064C

CD41 ~ CD45 HD5P48F0

CD41 ~ CD45 CD44 CD44 CD45

CD41 ~ CD45 HD5P48F0

CD41 ~ CD45 HD5P48F0

ARRANGE NO. 52

REVIEWS

NOTES:

R30 (80) UNLESS OTHERWISE INDICATED RESISTANCES ARE IN OHMS AND CAPACITANCES ARE IN MICRO-MICRO FARADS.

(1) UNLESS OTHERWISE INDICATED RESISTANCES ARE IN OHMS AND CAPACITANCES ARE IN MICRO-MICRO FARADS.

(2) \* VALUES ARE SELECTED IN MANUFACTURE.

BFO & CLARIFIER

3rd Angle System Dimension mm

JRC Japan Radio Co., Ltd.

N.R.D.: 9.3

0000

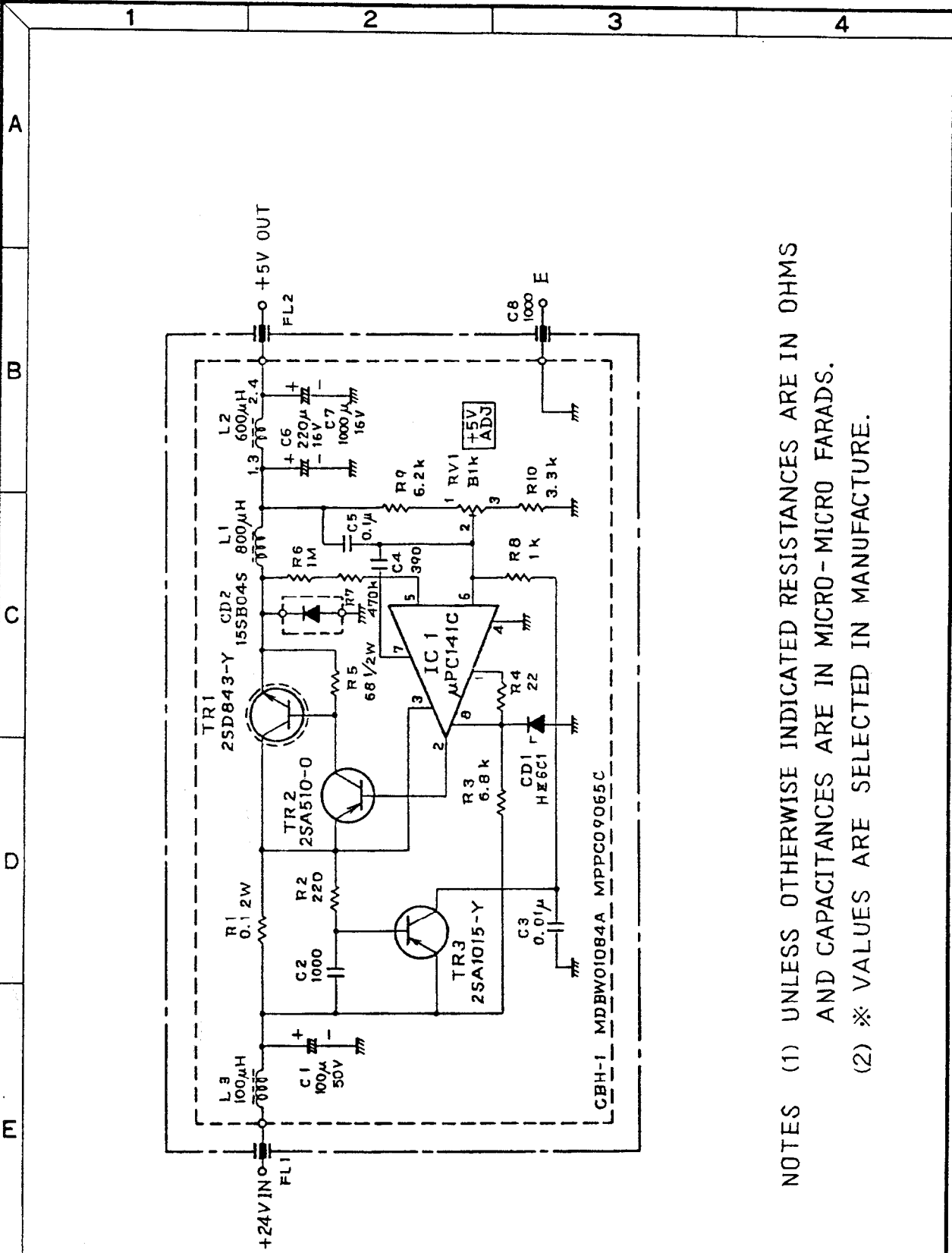

NOTES (1) UNLESS OTHERWISE INDICATED RESISTANCES ARE IN OHMS  
 AND CAPACITANCES ARE IN MICRO-MICRO FARADS.  
 (2) ※ VALUES ARE SELECTED IN MANUFACTURE.

ARRANGE NO.  
53

REVISIONS

APPROVED <i>[Signature]</i>		DATE	TITLE CBD-530 SWITCHING AVR CONNECTION DIAGRAM	SHEET NO. 11 / 11
CHECKED Y. Mizake	DESIGNED DRAWN Y. Kamikawa	SCALE A 4		
JRC Japan Radio Co., Ltd.			D D O O -	DRAWING NO.
			N R D - 9 2 / 9 3	

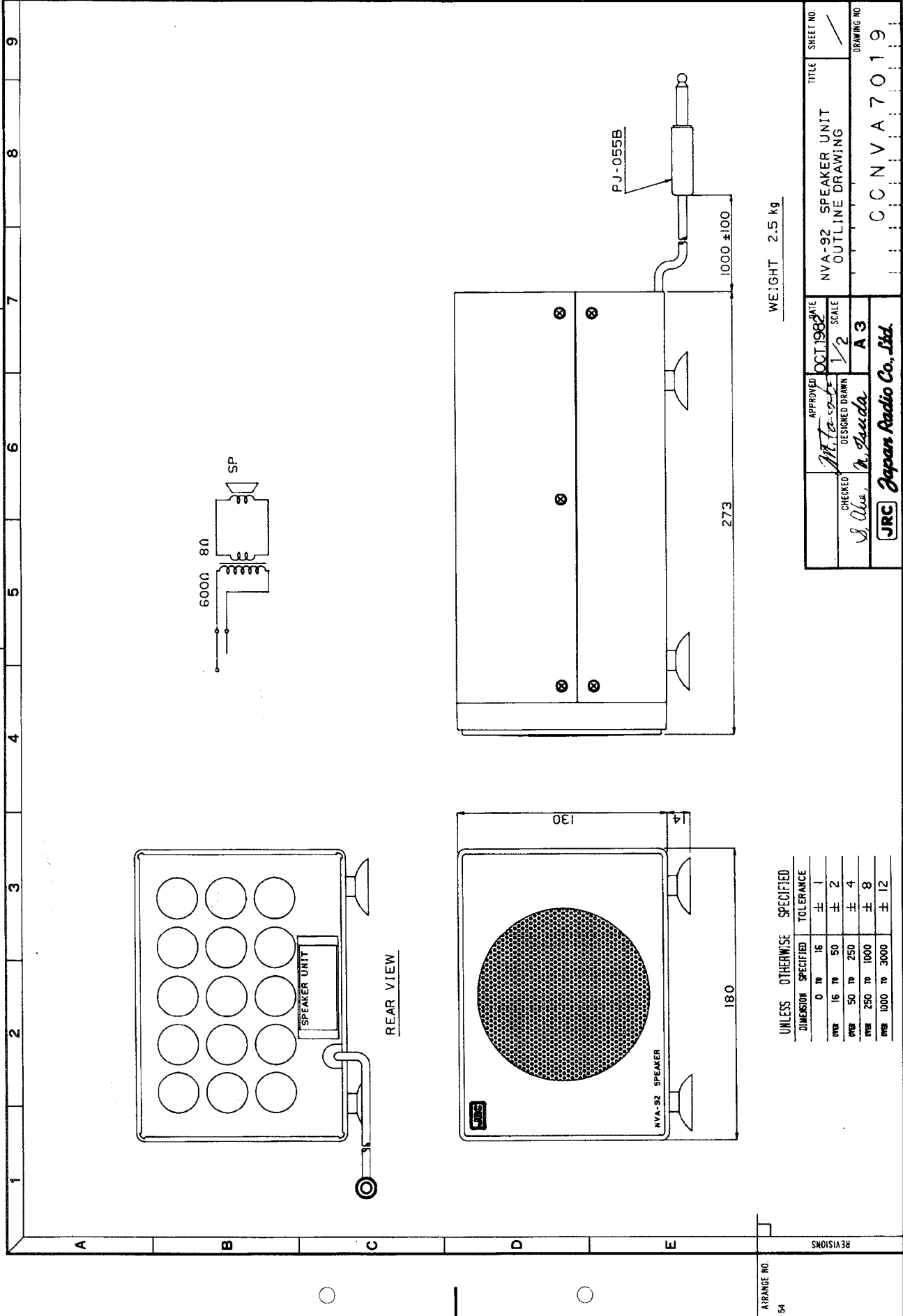

WEIGHT 2.5 kg

ARRANGE NO  
54

APPROVED	OCT. 1982	TITLE	SHEET NO.
<i>M. T. Saito</i>	DESIGNED DRAWN	NVA-92 SPEAKER UNIT	1
CHECKED	SCALE	OUTLINE DRAWING	
<i>S. Ota, K. Saito</i>	1/2		
	A 3		
JRC Japan Radio Co., Ltd.		DRAWING NO	
		CCNVA7019	

UNLESS OTHERWISE SPECIFIED

DIMENSION	SPECIFIED	TOLERANCE
mm	0 to 16	± 1
mm	16 to 50	± 2
mm	50 to 250	± 4
mm	250 to 1000	± 8
mm	1000 to 3000	± 12

3rd Angle System Dimension mm

REVISIONS

*For further information contact:*



*Since 1915*

*Japan Radio Co., Ltd.*

**HEAD OFFICE &  
SALES DEPT.**

17-22, Akasaka 2-chome, Minato-ku, Tokyo.  
Telephone : Tokyo(03)584-2411  
Telex : 0242-5420 JRCTOK J  
Cable Address : "JAPAN RADIO TOKYO"

**SALES OFFICE**

4-28, Dojima Hama 1-chome, Kita-ku, Osaka.  
Telephone : Osaka(06)344-1631  
Telex : 0523-6605 JRCOSA J

**MAIN FACTORY**

1-1, Shimorenjaku 5chome, Mitaka-shi, Tokyo.  
Telephone : Musashino(0422)44-9111  
Telex : 0282-2351 JRCMTK J

AB '84.8(1000)  
No. 61564