

**INSTRUCTION MANUAL**  
for  
**THE**  
**NATIONAL MODEL**  
**HRO - 5A1**  
**RADIO RECEIVING**  
**EQUIPMENT**

**An Outstanding Communications Receiver  
designed for optimum performance  
in Commercial and Amateur stations.**

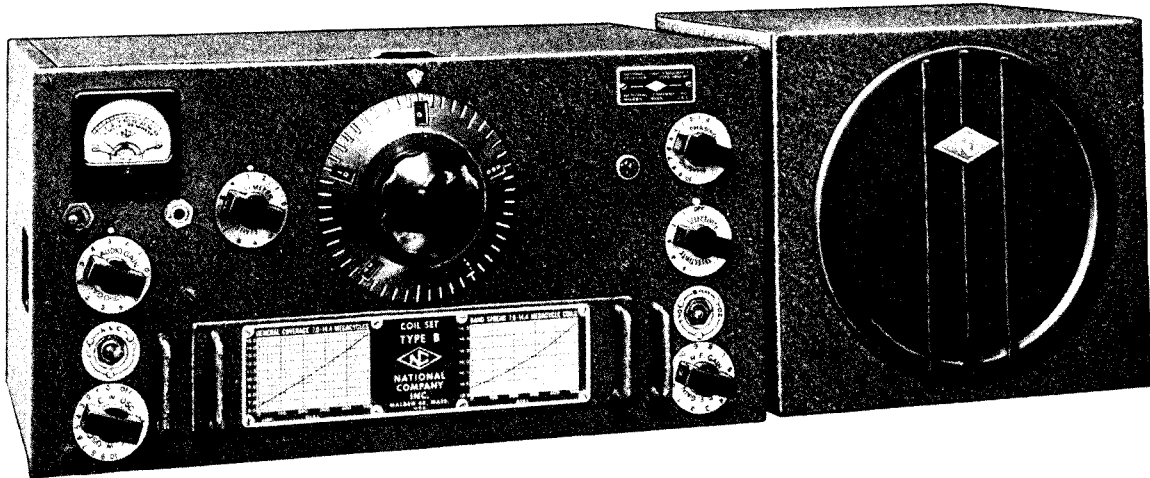



## HRO-5A1 RECEIVER

### FEATURES . . .

- Tuning Range 50-430 Kcs. and 480-30,000 Kcs..
- Nine Tuning Bands Accurately Calibrated
- Amateur Bands Calibrated to Within  $\pm 0.03\%$
- High Sensitivity
- Excellent Signal to Noise Ratio
- New, Flexible Crystal Filter
- Adjustable Threshold, Double Action Noise Limiter
- Temperature Compensation
- Plug-In Coils for Efficiency and Flexibility
- Separate Power Supply and Speaker

# THE HRO-5A1 COMMUNICATION RECEIVER

## SECTION I. DESCRIPTION

### I-1. General

The HRO-5A1 Radio Receiver is an eleven tube high-frequency superheterodyne suitable for C.W. and M.C.W. reception throughout the frequency range of 50 to 430 Kcs., and 480 Kcs. to 30,000 Kcs. This range is covered in nine bands as follows:

COIL SET	GENERAL COVERAGE	BANDSPREAD
A	14.0 - 30 Mc.	28.0-30.0Mc.
B	7.0 -14.4 Mc.	14.0-14.4Mc.
C	3.5 - 7.3 Mc.	7.0- 7.3Mc.
D	1.7 - 4.0 Mc.	3.5- 4.0Mc.
E	900 -2050 Kc.	
F	480 - 960 Kc.	
G	180 - 430 Kc.	
H	100 - 200 Kc.	
J	50 - 100 Kc.	

The Receiver may be obtained in either table or rack mounting models. Plug-in coil set Types A,B,C and D are normally supplied with the receiver, and coil set Types E,F,G,H and J may be obtained in addition, as desired. Coil set types A,B,C and D provide bandspread for the 10,20,40 and 80 meter amateur bands and each of these bands is spread over approximately 400 dial divisions on the main 500 division tuning dial. Coil set Types JA, JB, JC, and JD, which do not provide the bandspread feature, are available as may be desired.

### I-2. Circuit

The circuit employed on all bands comprises two tuned stages of radio frequency amplification, a tuned first detector, a high-frequency oscillator employing a tube separate from the first detector tube, a first intermediate frequency amplifier stage employing a variable-selectivity crystal filter, a conventional second intermediate frequency amplifier stage operating at 456 kilocycles, a combined second detector-automatic volume control - second audio stage, a first audio amplifier stage, an adjustable threshold series valve noise limiter, an audio output stage and a beat frequency oscillator coupled to the second

detector to provide for C.W. reception.

### I-3. Antenna Input

The Receiver is designed for operation with a single wire antenna or antennae employing transmission lines having impedances of 70 ohms or more. The actual antenna input impedance is between 300 and 600 ohms depending on the received frequency.

### I-4. Tube Complement

The HRO-5A1 Receiver is supplied complete with tubes which are tested in the receiver at the time of alignment.

The tubes employed are as follows:

First R.F. Amplifier.....	6K7
Second R.F. Amplifier.....	6K7
First Detector.....	6J7
High Frequency Oscillator.....	6J7
First I.F. Amplifier.....	6K7
Second I.F. Amplifier.....	6K7
First A.F. Amplifier.....	6J5
Diode Detector, AVC, Second Audio.....	6SQ7
Audio Output.....	6V6GT/G
Beat Frequency Oscillator.....	6J7
Noise Limiter.....	6H6

### I-5. Noise Limiter

The addition of a new, highly effective series valve noise limiter to the HRO-5A1 greatly improves the Receiver's capabilities under adverse receiving conditions. Its usefulness is most appreciated on the higher frequency bands of the receiver where automobile ignition noise and other high frequency disturbances are effectively suppressed. A front panel threshold control permits adjustment of the level at which limiting action starts. Since distortion effects are relatively unimportant in C.W. reception, the noise limiter may be advanced to a greater degree than would normally be employed on M.C.W. signals. In this operating condition there is provided a simulation of A.V.C. action for the reception of C.W. signals, a highly desirable feature. The noise limiter is of the double-acting type - limiting noise on both positive and negative peaks.

### 1-6. Crystal Filter

The crystal filter, located in the first intermediate frequency amplifier stage, is extremely flexible and of most efficient design. A six-position selectivity control and a crystal phasing control are front-panel mounted for adjustment of the crystal filter. Figure No. 1 shows the selectivity characteristics of the Receiver for each of the six positions of the selectivity control. The crystal filter may be used for either C.W. or M.C.W. reception; any degree of selectivity from true single-signal to broadcast reception being available. Operation of the phasing control provides for easy suppression of interfering signals which may produce objectionable heterodynes.

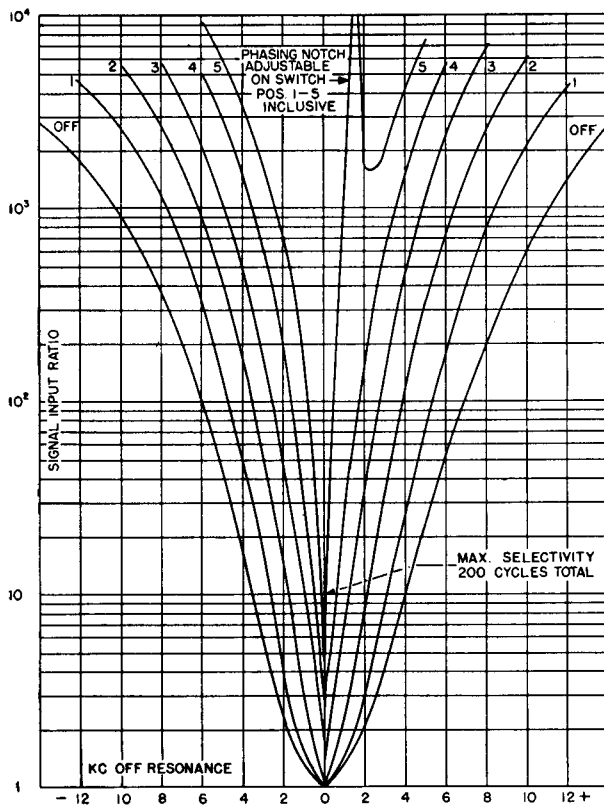

Figure No. 1. Crystal Filter Selectivity Curves.

### 1-7. Signal Strength Meter

Signal input readings are indicated in "S" units from 1 to 9 in 5 db. steps and in db. above S-9 from 0 db. to 40 db. on the

panel mounted signal strength meter. A reading of S-9 is obtained with an antenna input of approximately 50 microvolts. Accurate signal input readings from 0.5 microvolts to 5000 microvolts are possible. The meter employs a 0-1 milliamperere movement and is connected in a bridge circuit.

### 1-8. Audio Output

Two audio output circuits are provided. Loud-speaker terminals in the form of tip jacks, are located at the rear left-hand side of the receiver and a phone jack is mounted on the front panel. Normally, the plate circuit of the output tube is brought directly to the tip jacks and a separate permanent-magnet loud-speaker is connected to the tip jacks. The loud-speaker must have an impedance of from 5000 to 7000 ohms to properly load the output tube. The output transformer in this case is mounted on the loud-speaker and its primary carries the plate current of the output tube.

### 1-9. Power Supply

The Receiver can be used with the 697 Power Unit for 115 or 230 volt, 50 to 60 cycle A.C. operation or the 686S Power Unit for 6 volt D.C. operation. The Power Units are conservatively rated for use with the Receiver and will give long, trouble-free life.

### 1-10. Loud Speaker

RFSH or MCS Loud-speakers in rack or table mounting styles respectively can be used with the Receiver. These are permanent magnet type loud-speakers and have an output transformer which provides a proper impedance match for the output tube to the loud-speaker voice coil. This matching transformer has a primary impedance of 5000 ohms. In special models of the Receiver, an output transformer is mounted within the Receiver itself. In this case, the loud-speaker matching transformer must have a primary impedance which matches the Receiver output transformer secondary impedance. External means for supplying field excitation will be necessary if a dynamic speaker is to be used with the Receiver.

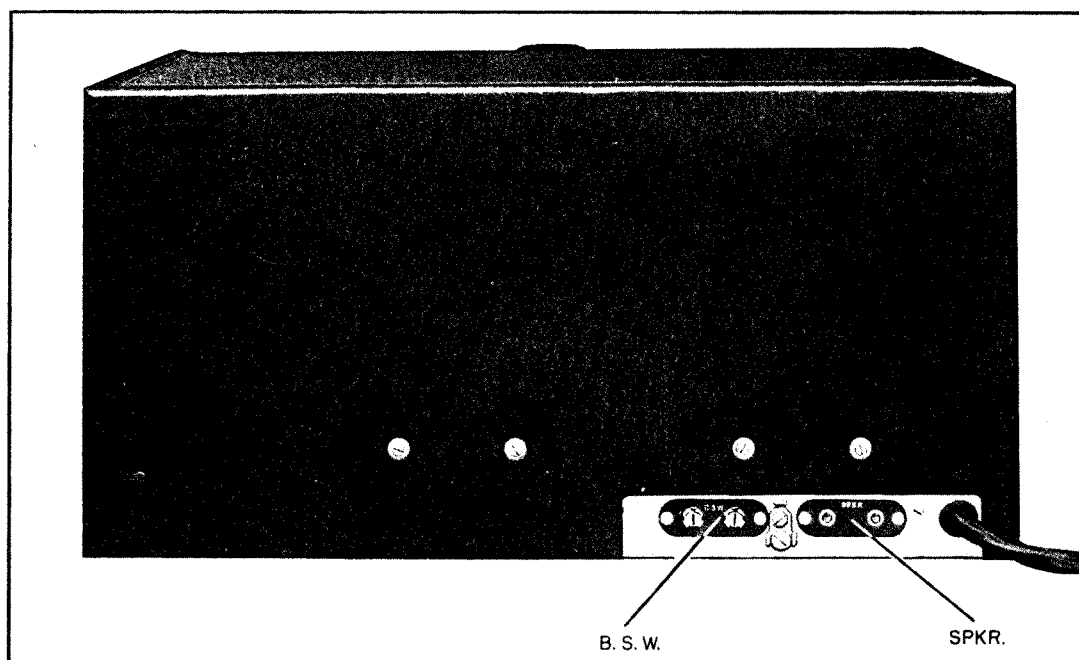

Figure No. 2. Rear View of Receiver

## SECTION 2. INSTALLATION

### 2-1. Arrangement

The Receiver, Power Unit and Loud-speaker may be arranged in any desired position although it is not recommended that the loud-speaker be placed on top of the Receiver as undesirable microphonics may result. Neither Power Unit nor Loud-speaker should be placed near the antenna terminals.

### 2-2. Antenna Recommendations

The radio frequency input of the Receiver is arranged for operation from either a single-wire antenna, a doublet antenna, or other types employing transmission lines having impedances of 70 ohms or more. There are two R.F. input binding posts at the left-hand end of the Receiver. A short, flexible, grounded lead is provided for grounding one input binding post in installations where a ground is required at the point of antenna input to the Receiver.

For best impedance matching to the Receiver input circuit an antenna with a 300 to 600 ohm transmission line is recommended. The antenna should be cut to the pro-

per length for the most used frequency. The antenna transmission line feeders should be connected to the antenna binding posts; the flexible grounding lead is not used. It must be remembered, however, that an antenna installation of this type will have maximum efficiency over a band of frequencies near that frequency for which it is designed and will be most useful in installations where the Receiver is tuned to one frequency or band of frequencies. For other frequencies, it would be desirable to connect the two transmission line leads together at the antenna post nearest the front panel of the Receiver, grounding the other binding post by means of the flexible lead. The antenna is thus utilized as a single wire type.

The most practical antenna for use in installations where the Receiver is to be used over a wide range of frequencies is the single-wire type. An antenna length of from 50 to 100 feet is recommended. The antenna lead-in should be connected to the antenna binding post nearest the front panel of the receiver; the other binding post should be grounded by means of the flexible

lead.

In an installation where the Receiver is to be used as the receiving unit in a transmitting station the most efficient operation will result from use of the transmitting antenna as receiving antenna also. This is especially true if the transmitting antenna is of the multi-element, directional type since the same antenna gain is available for both receiving and transmitting - a very desirable condition. Any transmission line of 70 ohms impedance or more may be used. For switching the antenna from receiver to transmitter, an antenna change-over relay should be used. A double pole, double throw relay possessing good high-frequency insulation is suitable. A second relay for controlling the transmitter plate supply and the Receiver B+ circuit may be used to achieve single-switch control of the station. This second relay should be a double pole, single throw type

having one normally open pair of contacts and one normally closed pair of contacts. The schematic diagram of this type of control circuit is shown in Figure 3. The relay contacts are shown in the normal or non-energized position. With S-1 OPEN (receive position) the antenna transmission line is connected to the Receiver by contacts 2 and 3 and contacts 5 and 6 on relay RY-1; contacts 7 and 8 on relay RY-2 are closed and complete the B+ circuit of the Receiver. With the switch S-1 closed (transmit position) RY-1 contacts 1 and 3 and 4 and 6 are closed transferring the antenna transmission line to the transmitter; contacts 9 and 10 of relay RY-2 close to complete the plate supply circuit to the transmitter. Contacts 9 and 10 of relay RY-2 should be in series with the primary of the transmitter plate supply transformer. Thus, the station is in the receiving condition with switch S-1 OPEN and in

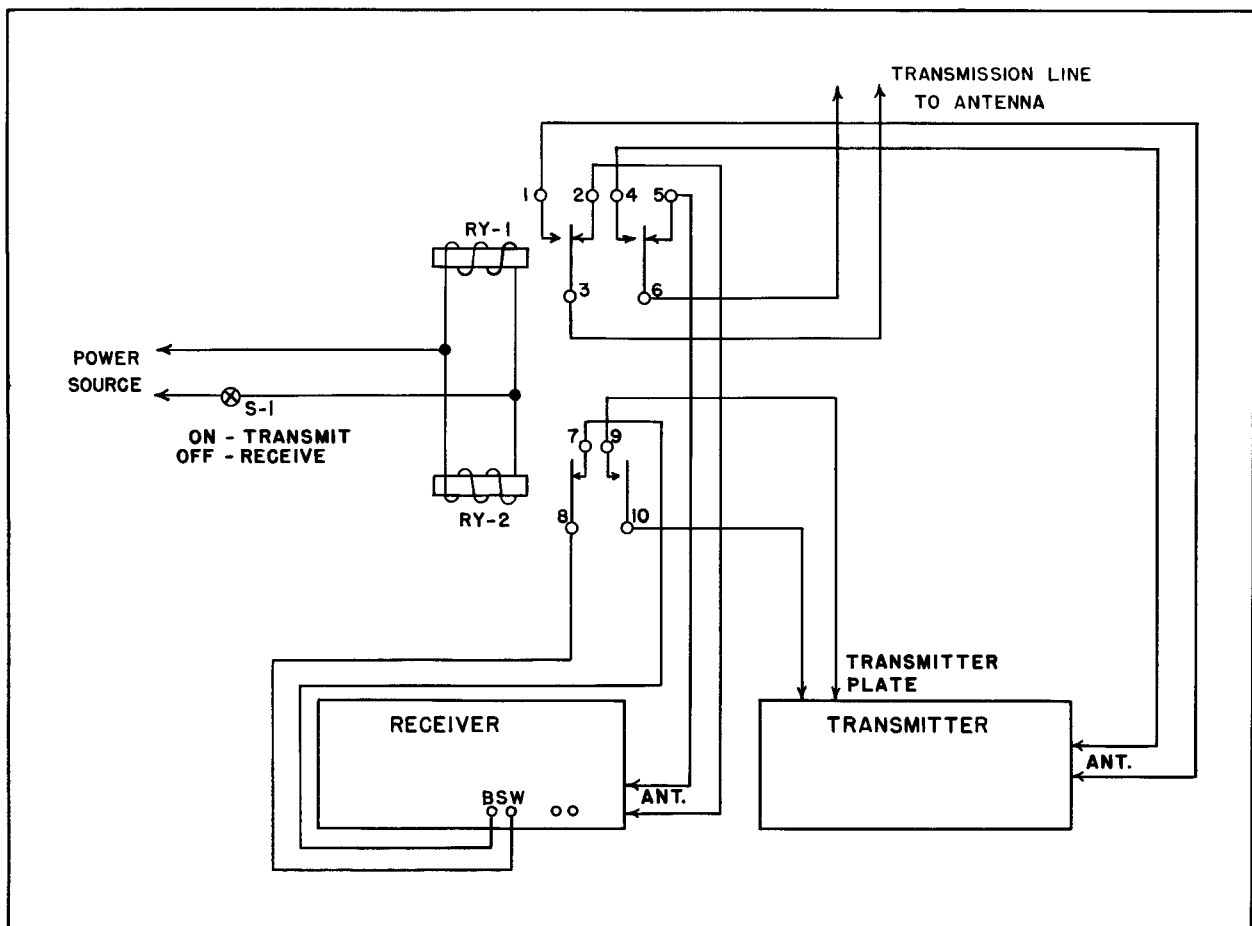

Figure No. 3. Typical Antenna Switching System

the transmitting condition with switch S-1 CLOSED. The power source for the relays RY-1 and RY-2 will be either 6 volts or 115 volts A.C. or D.C. depending on the power source available and the types of relays used.

When a doublet antenna is used, the antenna feeders or balanced transmission line are connected to the antenna binding posts. The flexible lead is not used.

The inner conductor of a concentric transmission line should be connected to the antenna binding post nearest the front panel of the Receiver. The outer conductor and the flexible grounding lead should be connected to the other binding post.

In some cases where a doublet antenna is used with a low impedance concentric or other type transmission line it may be necessary to re-trim the first R.F. amplifier at the high end of each band to provide a better impedance match between antenna and receiver input circuit. Paragraph 5-7 describes this procedure.

### **2-3. Installation Procedure**

After unpacking the Receiver and associated equipment, proceed as follows:

- (1) Make sure all tubes are seated firmly in their sockets.
- (2) Insert the Receiver power plug into the Power Unit output socket.
- (3) Connect Power Unit cord to proper source of voltage.
- (4) Connect antenna as recommended in Section 2-2.
- (5) Connect the loud-speaker to the tip jacks marked "SPKR" at the rear of the Receiver. If a loud-speaker is NOT going to be used a jumper MUST be connected between the "SPKR" tip jacks. If this precaution is neglected the output tube may be damaged due to excessive screen current.

The frequency at which reception is desired will determine the coil set used, in accordance with the calibration charts on the front panel of each coil set. If Bandsread coverage of one of the amateur bands is desired, as indicated by the calibration chart at the right-hand side of the front panel of coil sets A, B, C and D, the screws in each coil terminal panel should

be in the right-hand position. If General coverage is desired, the terminal panel screws should be in the left-hand position and calibration will be in accordance with the chart on the left-hand side of the coil set front panel. (See Section 4 concerning bandsread switching.) After selecting the proper coil set and adjusting for either Bandsread or General coverage, plug the coil set into the opening at the front of the Receiver. To avoid damage to the contacts it is important that the Receiver B+ switch be in the OFF position whenever coil sets are changed.

The Receiver is now ready for operation, and is turned on by means of the toggle switch mounted on the panel of the Power Unit. After allowing the tubes to reach operating temperature, the B+ circuit is completed by means of the toggle switch on the front panel of the Receiver, located directly above the R.F. GAIN control. This is a convenient stand-by switch.

A pair of terminals (BSW) at the rear of the Receiver provide a convenient means for connecting a relay or switch for remote control of the Receiver B+ circuits.

### **NOTE**

Where the Receiver is located in the R.F. field of a relatively powerful transmitter, it is advisable to provide some means of preventing damage to the Receiver R.F. coil. If a separate receiving antenna is used a means of disconnecting or grounding it during transmission periods should be provided.

### **2-4. Battery Operation**

The Receiver is readily adaptable to emergency or portable operation, or operation in locations where 115 or 230 volt A.C. power is not available. It may be operated directly from batteries or a National Type 686S Power Unit may be used for operation from a 6 volt storage battery. The Type 686S Power Unit draws 7.5 amperes at 6 volts when furnishing power to the Receiver. Battery drain may be decreased for headphone operation by removing the 6V6GT/G output tube from its socket. In this case, the Type 686S Power Unit draws 6 amperes at 6 volts.

The Schematic Diagram, Figure 8, shows a pin view of the Receiver power plug, thus providing the information necessary for wiring batteries to an auxiliary four-prong socket. The regular Receiver power plug may be inserted into this auxiliary socket to complete the power circuit. The normal B voltage required for operation of the Receiver is 240 volts at which voltage the receiver draws 70 milliamperes. Satisfactory headphone operation will result with a B voltage as low as 180 volts. The B battery life may be increased in this instance by removing the 6V6GT/G output tube from its socket as it is not used for headphone operation. With the output tube removed from its socket, the Receiver will draw 36 milliamperes at 180 volts. With the output

tube in operation the B battery drain is 65 milliamperes at 180 volts. To conserve battery power the Receiver power plug should be removed from the auxiliary battery socket when the Receiver is not being used. If greater convenience is desired, a single pole, single throw switch may be wired in series with the A+ lead to the battery to turn off the heater supply. If an A battery switch is used it is important that both the external A+ switch and Receiver B+ switch be turned OFF to conserve battery power when the Receiver is not being operated. The Receiver B+ switch will serve as a stand-by switch during transmission periods the same as for A.C. operation.

### SECTION 3. CIRCUIT FEATURES

#### 3-1. R.F. Amplifier Stages

The radio frequency amplifier stages are so designed that the receiver gain is essentially uniform throughout the entire tuning range of the Receiver. The impedance of a typical R.F. tuned secondary circuit decreases as the L/C ratio decreases, thus tending to reduce stage gain as the low frequency end of the tuning band is approached. Compensation for this effect is obtained by the use of high inductance primary coils in the interstage R.F. transformers. The high inductance primary is designed so that the primary circuit, as a whole, resonates broadly at a frequency outside the low frequency limit of the coil set tuning range. The primary circuit will, therefore, show increasing impedance as the tuning of the receiver approaches the low frequency end of the band. This resonant characteristic of the primary increases gain at low frequencies, over-compensating for the decreasing impedance of the secondary. In order to obtain the proper amount of compensation, a small coupling capacity is placed between the plate of the preceding tube, and the grid of the following tube. This capacity is most effective at the high frequency end of the band and combined with the resonant characteristic of the primary provides uniform

gain throughout the band.

A slightly different arrangement is employed for gain compensation in the 14 to 30 megacycle band. The interstage R.F. coupling transformers have three windings all closely coupled together. The primary winding connected in the plate circuit of the first R.F. tube is interwound with the tuned secondary winding and both have approximately the same number of turns. A third winding which feeds the control grid of the following R.F. amplifier tube is so designed that its natural period (or resonant frequency) falls just outside the low frequency end of the frequency band covered by the coil set. The impedance of this resonant secondary increases as the low frequency end of the tuning range is approached, thus tending to compensate for the unfavorable L/C ratio of the tuned secondary in much the same manner as the resonant primary system used in other coil sets. The self-resonant secondary arrangement is preferable, in the 14 to 30 Mc. band, as the resonant primary system is inadequate in its levelling action. It is not practical to include any gain compensation system in the coil sets for the 50 to 100 Kc. band.

#### 3-2. Band-Spread

The plug-in coil sets regularly sup-



plied with the receiver provide for band-spread of the 10, 20, 40 and 80 meter bands using coil sets A, B, C and D respectively. Each band is spread out so as to cover 400 dial divisions on the 500 division, main tuning dial. This is accomplished by placing small capacitors in series with each section of the main tuning capacitor, thus reducing its effective capacity range. These coil sets are aligned in the receiver at the National Laboratories using crystal controlled test oscillators assuring precise calibration. The frequency tolerance for the calibration of the amateur bands adhered to at the National Laboratories is  $\pm 0.03\%$ .

### **3-3. Temperature Compensation**

The receiver is compensated for frequency drift due to temperature changes occurring in circuits which may detune the receiver from the desired signal. While variations in room temperature are usually so gradual that drift resulting from this source is not objectionable, it is minimized through the use of air dielectric trimmer condensers, and the use of coil form material which has a small temperature coefficient. The cause of most objectionable frequency drift is the change of inductance of the high-frequency oscillator coil as heat from the tubes causes the interior of the receiver to increase in temperature. To minimize heating of the R.F. coils, the receiver is designed so that the coil sets are plugged into the very bottom of the receiver, underneath the chassis in a separate shielded compartment. The heat from the tubes will of course rise toward the top of the receiver and the R.F. coils will remain nearly at room temperature.

### **3-4. Crystal Filter**

A Crystal Filter affords six positions of selectivity in the HFO Receiver, ranging from broad-band selectivity for reception of broadcast signals to single signal selectivity for C.W. reception. The use of the Crystal Filter enables the operator to easily suppress an interfering signal by means of the PHASING control. With the SELECTIVITY switch in the OFF position, the PHASING control has little effect on receiver performance. In this

position, the nominal bandwidth is 8.0 Kc. at ten times down. Switching the Crystal Filter SELECTIVITY switch to position 1 gives a bandwidth of approximately 3.6 Kc., while with the SELECTIVITY switch in position 5 the bandwidth is about 1700 cycles. The PHASING control can be adjusted to suppress interfering signal frequencies differing from the desired signal by 300 cycles or more. The Crystal Filter employs a bridge type circuit which makes use of the high rate of reactance change with changes in frequency provided by a crystal to give the desired sharpness of selectivity. The reactance vs. frequency characteristic of the crystal is modified by damping, or loading the crystal by means of the tuned input circuit. When the input circuit is detuned, its effective resistance decreases and damping is greatly reduced, producing maximum selectivity. Detuning the input circuit does not materially affect the amplification of the receiver at the resonant frequency of the crystal since the series impedance of the circuit becomes very low when damping is reduced.

### **3-5. Beat Frequency Oscillator**

A beat frequency oscillator, which operates at or near the intermediate frequency is coupled to the second detector. The signal from this oscillator and the desired C.W. signal heterodyne at the second detector and produce an audio beat note thus providing a means for C.W. reception.

### **3-6. Automatic Volume Control**

Automatic Volume Control is provided for use only for M.C.W. reception. When the Beat Frequency Oscillator is turned on for C.W. reception it provides sufficient signal to operate the A.V.C. system and thus render the receiver extremely insensitive. For C.W. reception, therefore, the A.V.C. switch should be in the OFF position. However, the noise limiter, due to its peak limiting action, will provide A.V.C. action for the reception of C.W. signals. The limiter control may be advanced as desired to produce this A.V.C. action and may even be fully advanced to good advantage since the distortion is not detrimental to the reception of C.W. signals.

### 3-7. Noise Limiter

An adjustable threshold, series valve noise limiter provides very useful suppression of static peaks, automobile ignition noise and other high-frequency electrical noise fed to the receiver via the antenna. The degree of suppression and level at which noise limiter action occurs is adjustable by means of the limiter control on the front panel. When receiving M.C.W. signals, care in setting this control must be exercised since too much limiting action will cause audio distortion. However, when receiving C.W. signals the operator may take full advantage of the limiting action and provide AVC action as well as noise suppression, since distortion is not seri-

ous in this case. The 6H6 in the noise limiter stage is a duo-diode providing suppression of both the positive and negative peaks of noise.

### 3-8. Main Tuning Dial

The main tuning dial at the center of the front panel permits swift, accurate tuning and precise logging. This type of dial has an effective scale length of approximately twelve feet and is direct reading to one part in five-hundred. The dial drives the four-gang main tuning capacitor through a worm drive having a reduction ratio of 20 to 1. Back-lash is eliminated by the use of a spring-loaded split worm wheel which assures positive drive in either direction at all times.

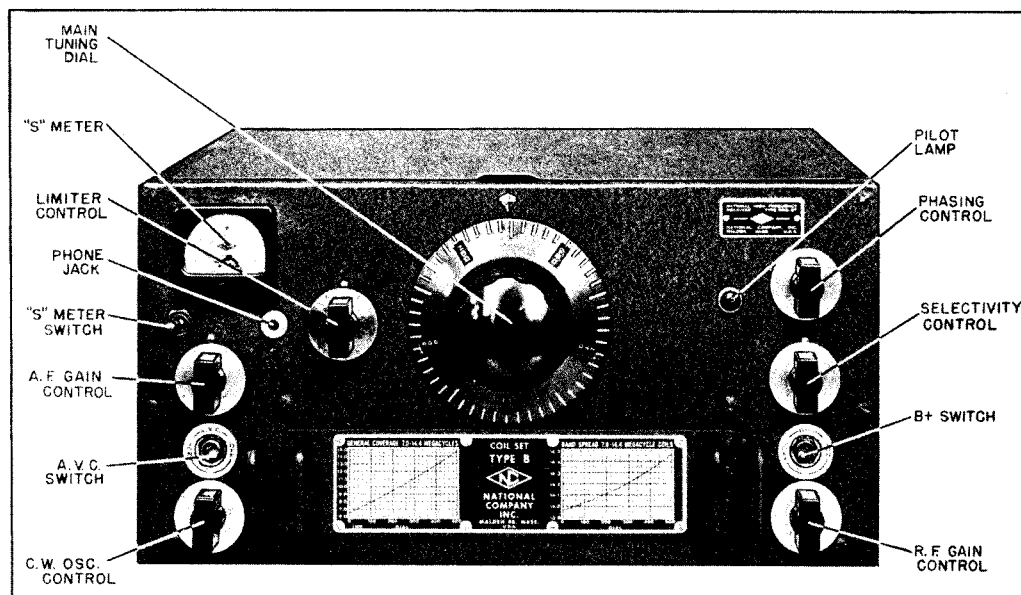

Figure No. 4. Front View of Receiver

## SECTION 4. OPERATION

### 4-1. Controls

The MAIN TUNING dial is located at the center of the front panel. The dial is so arranged that the frequency to which the receiver tunes increases as the dial reading increases. Each coil set is provided with a calibration chart showing the relationship between dial reading and frequency. An additional chart for bandsread calibration is provided on coil sets which

include the band-spread feature. Observation of each coil set tuning chart will show that the calibration is very nearly linear which eliminates considerable reference to the coil charts.

The R.F. GAIN control is located at the lower right-hand corner of the front panel and serves to adjust the amplification of the second B.F., first I.F. and second I.F. amplifier stages. Maximum sensitivity is obtained by rotating the con-

control knob to the extreme clockwise position, or 10, on its circular scale. In this position all tubes are operating at maximum gain with minimum bias. As the control is turned counter-clockwise, increasing bias is applied to the second R.F., the first I.F. and the second I.F. tubes, thus reducing their amplification.

The B+ ON-OFF switch is located directly above the R.F. GAIN control. This switch is connected in the positive lead of the power supply circuit and its purpose is to shut off the receiver during periods of transmission or WHEN CHANGING COIL SETS. This last function is important. The B+ circuits are completed when this switch is pushed to the right. Connected in parallel with the B+ switch and mounted at the rear of the chassis is a pair of contacts, marked B.S.W., intended for use with relay control of the receiver.

The PHASING and SELECTIVITY controls, located immediately above the B+ SWITCH, are a part of the crystal filter. When the SELECTIVITY control is set at OFF, the crystal is switched out of the circuit. With the crystal switched out, the phasing control has little influence on the receiver performance. With the SELECTIVITY control knob set at any point between 1 and 5, inclusive, the crystal filter is in operation, selectivity increasing as the knob is progressively advanced to position 5. The PHASING control is then used to balance the crystal bridge circuit and eliminate interfering signals or heterodynes.

The C.W. OSC. switch and vernier tuning control is located at the lower left-hand side of the front panel. The C.W. oscillator is used to produce an audible beat note when receiving C.W. signals or to locate the carrier of a weak M.C.W. station. Rotating the C.W. OSC. knob in a clockwise direction from OFF removes the ground from the cathode of the C.W. Oscillator, thus permitting it to oscillate. Further rotation of the knob from 0 on the scale to 10 varies the frequency of oscillation over a range of approximately 3 kilocycles. The C.W. Oscillator tunes to the receiver intermediate frequency at 9 on the graduated scale.

The A.V.C. switch is located directly

above the C.W. OSC. control. The automatic volume control circuits are operative when the toggle switch is pushed to the left.

The AUDIO GAIN control is located directly above the A.V.C. switch. Clockwise rotation of this control increases the signal applied to the triode section of the second audio tube. This control adjusts the volume level of the signal at both phone jack and loud-speaker terminals.

The LIMITER control, located just to the left of the MAIN TUNING dial, serves to adjust the D.C. potential applied to the elements of the series valve noise limiter tube. The limiter circuit is thus provided with an adjustable threshold at which limiting starts. Any audio voltages or noise peaks in excess of this threshold are prevented from reaching the audio amplifier. With the LIMITER control set at zero, the limiter circuits will pass all but the strongest audio peak voltages; when the control is set at ten, the threshold is lowered to a point where the audio signal will be distorted due to the suppression of the positive and negative peaks.

The S-METER for indicating carrier intensity or signal strength is on the upper left-hand corner of the front panel. Just below it and to the left, is a switch which connects the S-METER in the circuit.

The PHONE JACK is located just below and slightly to the right of the S-METER. When a phone plug is inserted into the PHONE JACK, the loud-speaker is automatically silenced.

The BANDSPREAD switch for each of the four bandsread coil sets is located on each coil set. Inspection of the coil set terminal panels will show several small rectangular metal pieces. There are two of these metal pieces or terminal blocks on each coil which are tapped and countersunk for a flat-head machine screw. With the screws in the left-hand position, the coil range will be that shown in the left-hand or general coverage chart. It is only necessary to move each of the four screws to the right-hand terminal block of each coil to change the calibration from general coverage to BANDSPREAD as shown on the right-hand chart.

#### **4-2. C.W. Reception**

After the HRO-5A1 is properly installed it is put in operation by turning both the Power Unit switch and the Receiver B+ switch to the ON position. The LIMITER control should be set at 0. The C.W. OSC. control should be turned on and the A.V.C. switch must be pushed to the right to render the A.V.C. circuits inoperative. If the A.V.C. switch is turned on with the C.W. oscillator in operation, the Receiver will block and become extremely insensitive. The Receiver is now adjusted for C.W. reception and will tune in accordance with the frequency calibration of the coil set in use.

Although the settings of the R.F. GAIN and A.F. GAIN controls will depend to some extent upon operating conditions, it is recommended that the A.F. GAIN control be set at 5 and the R.F. GAIN control advanced as may be required to provide a satisfactory audio signal. Advancing the R.F. GAIN control too much may cause I.F. or second detector overload. Such overload is indicated by a change in pitch of the C.W. beat note over the duration of a code character, or by excessive "thumping".

The best setting of the C.W. OSC. control will also depend upon operating conditions. When the received signal is free from interference and is sufficiently strong to override static and circuit noise, it is recommended that the C.W. OSC. control be set at the position which tunes the C.W. oscillator to the intermediate frequency of the receiver. This setting will normally be between 8 and 10 on the C.W. OSC. dial. As the control is turned toward 0, the C.W. oscillator is progressively detuned from the intermediate frequency of the receiver.

The operator can tell the extent of this deviation by listening to the characteristic pitch of background and circuit noises. When this pitch is 2000 or 3000 cycles per second, it will be found that the receiver has definite single-signal properties such that on one side of the carrier, the audio beat note of a received signal will be considerably louder than that of the other side. This characteris-

tic is helpful in receiving weak signals through interference and utilizes the maximum available sensitivity of the receiver.

If receiving conditions are such that static peaks or noise pulses of high intensity and short duration are present, the best signal-to-noise ratio is obtained by advancing the LIMITER CONTROL toward 10. Maximum limiter action is possible for reception of C.W. signals since audio distortion is not important. At the same time using strong limiter action has the further advantage of providing A.V.C. action for C.W. reception.

#### **4-3. Phone Reception**

The initial adjustment of the HRO-5A1 Receiver for reception of M.C.W. signals is the same as for C.W. reception except that the C.W. OSC. control should be turned off. For M.C.W. reception, the C.W. oscillator may be useful in locating the carrier of a weak phone or broadcast station. After the phone carrier has been located, the C.W. oscillator is turned off. With the A.V.C. OFF the setting of the A.F. GAIN and R.F. GAIN controls will depend to some extent upon operation conditions. It is recommended that the A.F. GAIN control be set at about 5 and the R.F. GAIN control advanced as may be required to provide a satisfactory audio signal. When receiving weak signals, best signal-to-noise ratio will be obtained by retarding the A.F. GAIN control and advancing the R.F. GAIN control to a point as near maximum as receiving conditions will permit. Care must be exercised to prevent overloading the I.F. or second detector stages under these conditions. Overload will be indicated by excessive audio distortion.

To receive M.C.W. signals with automatic volume control, the A.V.C. switch must be placed in the ON position. The R.F. GAIN control should be advanced to a point as near maximum as receiving conditions will permit. Audio output should be controlled entirely by means of the A.F. GAIN control. When the noise level is high, the R.F. GAIN control may be retarded to limit the overall sensitivity of the receiver to a definite maximum. It should be remembered, however, that the

full range of A.V.C. action cannot be obtained unless the R.F. GAIN control is fully advanced.

The action of the LIMITER control is similar to that described under Section 4-2. The best setting of the LIMITER control will be determined by trial since too much limiting action will cause distortion of the audio output. If the noise pulses and static peaks are of large amplitude or of long duration the best signal-to-noise ratio will be obtained with the A.V.C. switch in the OFF position. In this operating condition, the optimum signal-to-noise ratio must be obtained by careful adjustment of both the R.F. GAIN and LIMITER controls.

#### **4-4. Reception with Crystal Filter**

The crystal filter may be used advantageously in the reception of both C.W. and M.C.W. signals to adjust the selectivity of the receiver and also to suppress interfering signals or heterodynes.

For M.C.W. reception the normal setting of the SELECTIVITY control is at one of the positions affording broad selectivity. Positions 1 and 2 are recommended. Selectivity may be progressively increased by turning the SELECTIVITY control to positions 3, 4 and 5 although too sharp selectivity for M.C.W. reception will render phone signals unintelligible due to excessive side-band cutting. The PHASING control is used to attenuate, or eliminate, if possible, interfering signals. The PHASING control is normally set at 0 on the scale for reception of M.C.W. signals. If, after tuning in a signal, an interfering signal causes a heterodyne or whistle, the PHASING control should be adjusted until the interfering signal is reduced to a minimum. The setting of the PHASING control which gives maximum attenuation of the heterodyne will depend on the pitch of the heterodyne whistle. If the beat-note is above 1,000 cycles, the optimum PHASING control setting will be zero; if the beat-note is 300 or 400 cycles, the optimum PHASING control setting will be near one end of the scale or the other, depending upon whether the interfering signal is higher or lower in frequency than the desired signal.

For the reception of C.W. signals the action of the crystal filter is similar to that for M.C.W. reception except that full use of the sharp selectivity position may be used without the loss of intelligibility experienced in M.C.W. reception. When maximum selectivity is used, (SELECTIVITY control at position 5), care must be exercised since the tuning is very critical. When the receiver is slowly tuned across the carrier of a received signal, the beat-note produced will be very sharply peaked in output at a particular audio pitch. This peak in response indicates the correct receiver dial setting. The setting of the C.W. OSC. control must be such that the beat-note peak is well within the audible range so that the receiver peak response may be readily observed. A C.W. OSC. dial setting near 7 is recommended. After the receiver has been correctly tuned, the pitch of the beat-note peak may be adjusted by means of the C.W. OSC. control to provide an audio tone which is pleasing to copy, or coincides with any response peaks in the speaker or headphones. Under these conditions, the receiver will exhibit pronounced single-signal properties which may be demonstrated by tuning the receiver to the other side of "zero-beat" so that the pitch is the same as before and observe the marked reduction in output. This dial setting is not recommended for use other than to demonstrate the single-signal properties of the receiver. With the receiver tuned to "crystal peak", an interfering signal may be attenuated by proper setting of the PHASING control since this control has little effect on the desired signal.

#### **4-5. Measurement of Signal Strength**

To measure the strength or intensity of a signal, the R.F. GAIN control must be advanced to 9.5 and the A.V.C. switch turned to the ON position. The crystal filter should be turned OFF by means of the SELECTIVITY control, and the PHASING control set at 0. The LIMITER and A.F. GAIN controls do not affect the S-METER reading.

Tuning the receiver to a signal will cause the meter to read, indicating the signal input in S-units or in decibels a-

bove the S-9 level.

With no R.F. input to the receiver, or with the antenna disconnected, the S-meter should read 0, plus or minus 1 S-unit. If it does not, the S-meter circuit requires

adjustment. See Section 6.

Measurement of the signal strength of C.W. signals cannot be made with the C.W. oscillator in operation.

## SECTION 5. ALIGNMENT DATA

### 5-1. General

Should realignment of the HFO-5A1 Radio Receiver become necessary the following alignment data should be carefully studied before making any circuit adjustments. It is important that the function of each circuit element is understood so that correct alignment may be obtained quickly and accurately. Adjustments referred to by number are shown in Figures 5 and 7.

The complete alignment of the receiver may be divided into five steps:

- (a) Intermediate Frequency Amplifier alignment including crystal filter adjustments.
- (b) High Frequency Oscillator alignment.
- (c) Radio Frequency Amplifier alignment.

- (d) Tracking of High Frequency Oscillator and Radio Frequency Amplifier circuits.

- (e) Bandsread Adjustments.

### 5-2. I.F. Amplifier Alignment

The making of any adjustment indiscriminately is cautioned against and no circuit should be realigned unless tests definitely indicate that realignment is necessary.

The Alignment of the Intermediate Frequency Amplifier may be easily checked in the following manner. The receiver should be adjusted for normal operation with no antenna, AVC OFF, R.F. GAIN at 9, crystal Filter SELECTIVITY switch at 5, PHASING control at 0, and C.W. OSC. turned ON. The setting of the A.F. GAIN control does not affect the meas-

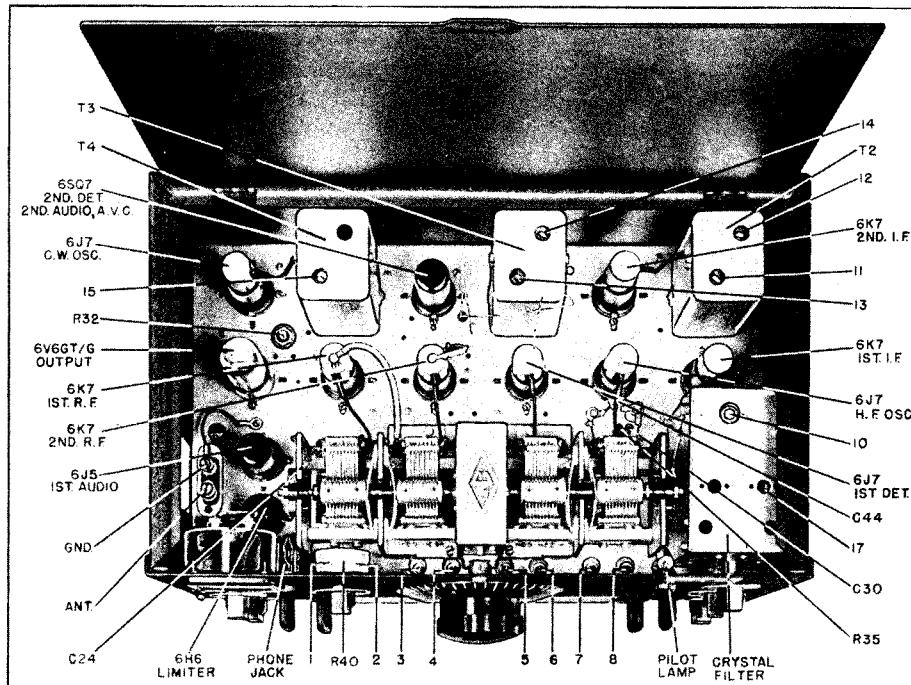

urement and may be adjusted to provide sufficient output to make the required observations. The C.W. OSC. control should then be turned until a point is found where the predominant pitch of the background noise is lowest and a crystal ring is heard. This setting of the C.W. OSC. control should occur near 9 on the C.W. OSC. scale and the exact setting should be noted. The crystal filter should then be disconnected from the circuit by turning the SELECTIVITY control to the OFF position. The C.W. OSC. control should again be adjusted for the lowest predominant pitch of background noise and this new setting noted. If the I.F. Amplifier alignment is correct, the setting of the C.W. OSC. control should be the same for both tests outlined above. The I.F. Amplifier should not be realigned, however, unless the test shows appreciable misalignment.

The intermediate frequency of the HRO-5A1 is 456 kilocycles, plus or minus 2 kilocycles. The exact frequency is determined by the quartz crystal resonator in the crystal filter.

Trimmer capacitors are provided on the crystal filter and on each I.F. transformer. These capacitors are numbered 9, 10, 11, 12, 13, 14, 17 on Figure No. 5.

The high output lead of an accurately calibrated signal generator should be connected to the grid terminal of the first detector tube and the ground lead to any convenient point on the chassis. The flexible lead need not be disconnected from the grid of the tube. A dummy antenna is not used. The C.W. OSC. should be turned on and the modulation of the signal generator turned off to provide a steady C.W. test signal. Set the PHASING control at 0, the SELECTIVITY control at 5, and the A.F. GAIN control at maximum or fully advanced. An output meter should be connected to the output terminals of the receiver.

The signal generator should be tuned to approximately 456 kilocycles and its output adjusted to give a convenient reading on the output meter. Tune the signal generator to the frequency producing maximum reading on the output meter; a definite sharply peaked response will be noted. The

signal generator output should be reduced now in order to avoid I.F. or audio overload and the C.W. OSC. should be adjusted to give an audio beat-note at some frequency between 400 and 1000 cycles per second.

The I.F. amplifier trimmer capacitors, numbers 9, 11, 12, 13 and 14, should be carefully tuned to produce a maximum reading on the output meter. The order of adjustment is not important. While tuning the I.F. amplifier trimmer capacitors it will be necessary to reduce the signal generator output if the I.F. amplifier gain increases to the overload point.

The crystal filter SELECTIVITY control should be set at 1 and the signal generator detuned between 3 and 4 kilocycles to one side of the crystal frequency, crystal filter trimmer capacitor Number 10 should be tuned for maximum output meter indication. After making this adjustment, the SELECTIVITY control should be set at off and the signal generator retuned to exact crystal frequency. Compensator trimmer capacitor Number 17 should then be tuned for maximum reading on the output meter.

After the I.F. amplifier has been aligned, the tuning of the C.W. OSC. should be checked. This may be readily accomplished by repeating the test previously described with the crystal filter off. If the setting of the C.W. OSC. control does not occur at or near 9, with this test, turn the C.W. OSC. control to 9 and carefully adjust trimmer Number 15 by ear for the lowest pitch of background noise.

### **5-3. High Frequency Oscillator Alignment**

The need for realignment of the high frequency oscillator of any band is indicated when the frequency calibration of the receiver dial is in error by more than 3% at the high frequency end of the band in question. If there is doubt concerning the necessity for high frequency oscillator realignment, this portion of the circuit should not be adjusted as correction can be made by R.F. amplifier trimmer adjustments.

If the frequency calibration of a coil set is in error by more than 3%, it should be corrected in the following manner:

(a) Adjust the receiver for normal operation as follows: R.F. GAIN at 9, C.W. OSC. off, A.V.C. off, Crystal Filter off, A.F. GAIN set to provide a suitable signal level.

(b) Adjust an accurately calibrated signal generator to provide a signal which should be tuned in near 490 on the receiver dial according to the general coverage calibration chart for the coil set in use.

(c) Tune the receiver to the test signal and compare the dial reading with the calibration chart.

(d) When the receiver dial reading is too low, more circuit capacity is required and is supplied by adjustment of trimmer Number 8. When the receiver dial reading is too high, less circuit capacity is required and is removed by adjustment of trimmer Number 8.

It is particularly important that the high frequency oscillator operates above the R.F. amplifier frequency and not below. This can be checked by tuning in the test signal as an image which is normally 912 kilocycles lower on the receiver dial. The image signal should be much weaker if the R.F. amplifier is correctly aligned and a stronger test signal may be required in order to hear the image. If the image signal appears at a higher dial setting rather than a lower dial setting, the high frequency oscillator is incorrectly adjusted and the capacity of trimmer, Number 8, must be decreased until the real signal and image signal each appear at the proper points on the dial.

#### **5-4. R.F. Amplifier Alignment**

The term R.F. amplifier alignment, as used in this section, includes alignment of both R.F. Amplifier and First Detector circuits.

The receiver should be adjusted as in paragraph (a) 5-3. No Antenna is required. Turn the receiver dial to 490 and adjust trimmers, Numbers 2, 4, and 6, for maximum background noise, which is the setting for maximum gain.

#### **5-5. Tracking of the H.F. Oscillator and R.F. Amplifier Circuits**

Tracking of the H.F. Oscillator and R.F. Amplifier circuits may be readily

checked by observing the background noise while tuning over the range of the coil-set in use. The background noise should not vary greatly as the dial is turned toward the low frequency limit of the coil set tuning range. The actual tracking of each stage near the low frequency limit of the tuning range may be checked by pressing the outside rotor plates of the main tuning condenser section toward or away from the stator, but not far enough to short the condenser or permanently bend the rotor plates. Any change in capacity should decrease the background noise indicating decreased sensitivity, if the stage is tracking properly. Coil sets which may require precise adjustment of circuit elements are provided with adjustable series padders in the high frequency oscillator position of the coil set, which can be adjusted to track with the average adjustment of the R.F. amplifier coils. This series padder is mounted inside the coil and is adjustable from the rear by means of a screwdriver. It should be remembered that the series padders found in the coils of coil-set types A, B, C and D are bandspread series padders and should not be adjusted except during bandspread alignment.

After calibration and alignment at the high-frequency end of the coil set have been accomplished, as explained in Section 5-3, the tracking may be adjusted as follows:

(a) With the receiver adjusted as in Section 5-4, turn the receiver dial to 20.

(b) Test the tracking of each stage in turn by bending the outside rotor plate of each section of the main tuning capacitor. DO NOT BEND the rotor plate of any section to such an extent that it will not spring back to its original position.

(c) Adjust the H.F. oscillator series padder to its optimum tracking position when step (b) above gives indication of poor tracking.

(d) Turn the receiver dial to 490 and adjust trimmer Number 8 to give the proper calibration with the new series padder adjustment.

(e) Repeat (a), (b), (c) and (d) until best tracking is obtained.

(f) Note any slight tracking errors occurring in the R.F. Amplifier stages so



that if the same error occurs in a majority of the coil sets, the outside rotor plate may be permanently bent to provide the best tracking for the stage involved.

### **5-6. Band-Spread Alignment**

The following data applies only to coil sets which include the bandspread feature; coil-set Types A,B,C and D. Adjustments made for general coverage will affect the bandspread adjustments, but the separate bandspread adjustments may be made without changing the general coverage alignment. The four screws used to switch from general coverage to bandspread must be shifted to the right-hand terminal blocks before any bandspread alignment adjustments are made.

The need for realignment of the H.F. oscillator section of any coil set is indicated when the frequency calibration of the main tuning dial is in error by more than 30 divisions at the high frequency end of the band in question.

(a) If the frequency calibration of a coil set is in error, realignment may be accomplished in the following manner:

(1) Repeat the procedure of Section 5-3 with the exceptions that the test oscillator frequency is chosen so as to be tuned in at 450 on the receiver dial as indicated by the bandspread tuning chart and correction for calibration error is made by adjustment of trimmer number 7.

(b) The alignment of the R.F. amplifier for bandspread operation is similar to that for general coverage so the procedure of Section 5-4 should be repeated with the exception that the receiver dial should be turned to 450 and trimmer Numbers 1,3 and 5 should be adjusted for maximum background noise.

(c) The adjustment and method of checking bandspread tracking is not similar to that for general coverage. The following procedure should be used for bandspread tracking adjustments.

(1) With the receiver adjusted as in paragraph (a) above turn the receiver dial to 50.

(2) Check the receiver calibration at dial reading 50 against an accurate test oscillator.

(3) Adjust the H.F. oscillator ser-

ies padder located inside the H.F.O. coil shield to provide the correct dial calibration.

(4) Turn the dial to 450 and adjust trimmer Number 7 to give the proper calibration.

(5) Turn the dial to 50 and check the calibration. Repeat (3) and (4) if necessary.

(6) With the receiver dial at 50 check the settings of trimmers, Numbers 1, 3 and 5 for the position of maximum background noise.

(7) If it is found that increasing or decreasing the capacity of trimmer 1,3 or 5 increases the background noise, adjust the associated series padder located inside the coil shields to provide the required capacity.

(8) Turn the receiver dial to 450 and adjust trimmers 1,3 and 5 for maximum background noise.

(9) Repeat (6) and (8), also (7) if necessary.

### **5-7. First R.F. Stage Alignment with Low Impedance Transmission Line**

If a low impedance transmission line is to be used with the Receiver, it may be necessary to realign the first R.F. amplifier at the high end of each band. The general coverage adjustments affect the bandspread adjustments and should be performed first. The following procedure should be adhered to:

(a) General Coverage:

(1) With the four screws used for switching from general coverage to bandspread in the left-hand (general coverage) position, adjust the receiver for normal operation as follows: R.F. GAIN at 9, C.W. OSC. off, A.V.C. off, CRYSTAL FILTER off, A.F. GAIN set to provide a suitable signal.

(2) Connect the antenna feeders to the Receiver antenna binding posts and tune the receiver to a Signal at approximately 490 on the Receiver dial. Adjust trimmer Number 2 for maximum signal output. If no signal can be received, the trimmer should be adjusted for maximum background noise.

(b) Bandspread:

(1) With the receiver adjusted the same as for general coverage, shift the

four screws on the coil terminal panels to the right-hand position (bandspread position).

(2) Connect the antenna feeders to the Receiver antenna binding posts and tune the receiver to a signal at approximately 450 on the Receiver dial. Adjust trimmer Number 1 for maximum signal output. If no signal can be received the trimmer should be adjusted for maximum background noise.

**5-8. S-Meter Adjustment**

The S-meter balancing resistor R-32, is used to obtain zero meter reading in the absence of signal input to the receiver. The adjustment is as follows: Set the R.F. GAIN control at 9.5, AVC ON, and disconnect the antenna. R-32 should now be adjusted until the S-meter reads zero.

**SECTION 6. MAINTENANCE**

**6-1. General Maintenance Data**

Any repairs in the HRO-5A1 Receiver which necessitate resoldering of joints should be made with care. A good mechanical connection should be made before the solder is applied.

Failure of a vacuum tube in the receiver may reduce the sensitivity, produce intermittent operation, or cause the equipment to be completely inoperative. In such cases, all tubes should be checked either in an analyzer or similar tube testing equipment, or by replacement with tubes of

proven quality. When any tube is tested, it should be tapped or jarred, to make sure that it has no internal loose connection or intermittent short circuit.

When tube replacements become necessary, substitution of new tubes may alter the alignment of the R.F. or I.F. circuits inasmuch as the replacement tubes may not be identical with those originally employed. The necessity for realignment as well as alignment procedure is discussed in Section 5

In case of breakdown or failure of the receiver, the fault must first be local-

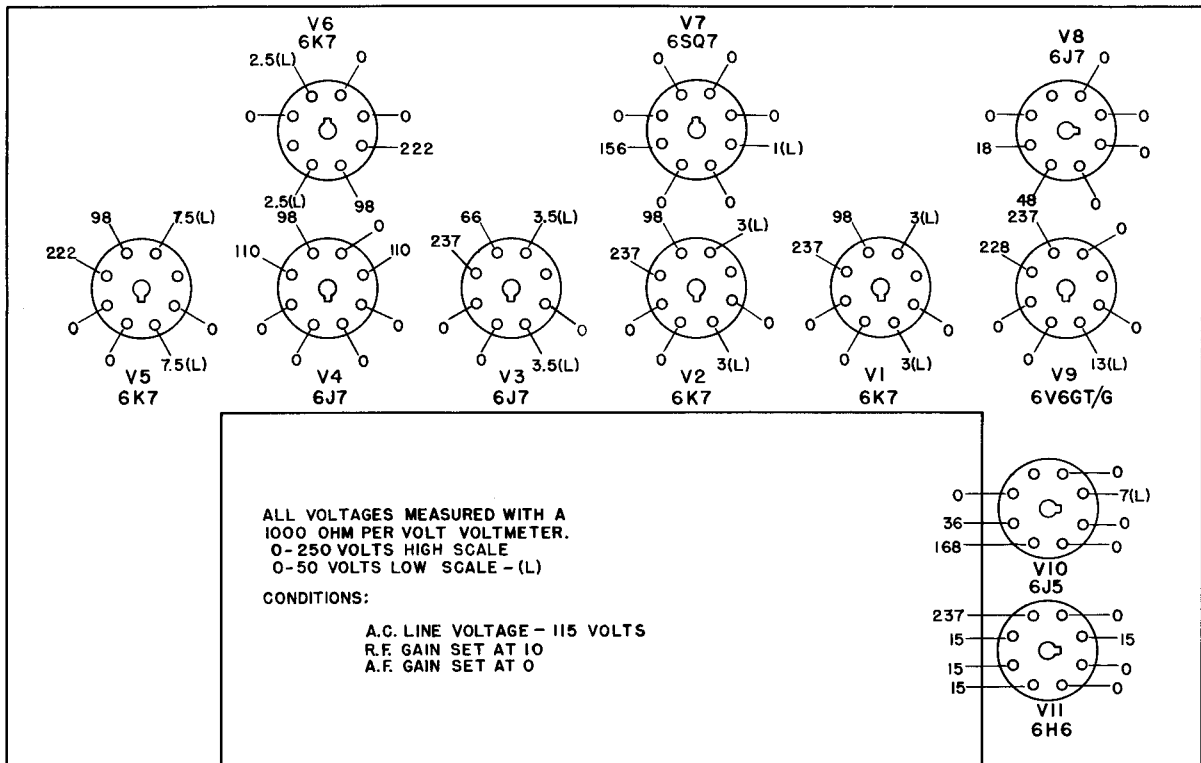

Figure No. 6. Tube Socket Voltages

ized. This can often be accomplished by observation of some peculiar action of one of the controls. Reference to the circuit diagram will aid in checking voltages at the various tube elements.

Bypass or filter capacitors which develop poor connections internally, or which become open-circuited, will cause decreased sensitivity, oscillation or poor stability. The defective unit can be located by temporarily connecting a good capacitor in parallel with each capacitor that is under suspicion.

Failure of any bypass or filter capacitor may seriously overload resistors in associated circuits. Overloads of sufficient magnitude to permanently damage a resistor will cause the surface of the resistor to be scorched, making the defective unit easy to locate by visual inspection.

Open or short-circuited resistors can be definitely located by measuring the resistance of each individual resistor. The wiring diagram should be consulted to make sure that any particular resistor under test is not connected in parallel with some other circuit element which might produce false measurement.

Loose connections which cause intermittent or noisy operation can often be found by tapping, or shaking, any component under suspicion, with the receiver adjusted for normal operation.

### **6-2. Main Tuning Dial**

The main tuning dial should normally give no trouble. If, however, the dial should become removed from the receiver it should NOT be operated until mounted on the condenser shaft WITH SET-SCREWS TIGHT. This is because the dial is only designed to rotate for ten revolutions (0 to 500) and if turned farther than this the mechanism will be damaged. When mounted on the condenser, limit stops protect the dial provided the assembly is properly done. The procedure for re-mounting the dial is as follows:

(a) Place dial on condenser shaft, tighten set-screws and turn dial counterclockwise to fully mesh condenser rotor plates so that the tips of the rotor plates are flush with the edge of the stator plates.

(b) Loosen set-screws and rotate dial slowly until dial reading has decreased to zero.

(c) Tighten the set-screws.

(d) Check position of rotor plates at zero. The tips of the rotor plates should be flush with the edge of the stator plates at zero. A slight adjustment may be necessary and this is done by loosening the set-screws, adjusting the position of the dial and tightening the set-screws again.

If it is necessary to remove the dial at any future time, turn to 250 before removing the dial, and do not disturb the setting of either the dial or condenser until reassembled. If in doubt about the correct position, inspect the springs on the back of the dial. When the dial reads 250 these springs should be straight-up-and-down, they must not be tipped to one side.

It is important that the backplate and dial do not become separated.

The backplate is held in place by two springs so that its gear teeth mesh with the dial gear teeth in correct relationship for proper dial operation. If this backplate should be sprung out of place, it may return to an incorrect position and the proper dial numbers will not appear in the windows when the dial is used. To ascertain that the two parts are in correct position, proceed as follows:

(a) Locate small window near outer periphery of dial backplate and also locate dial number window on face of dial which is 180° removed from the small backplate window.

(b) Hold dial so backplate lies flat in palm of left hand and with right hand rotate dial knob until 250 appears in previously located dial window.

(c) If dial is properly adjusted it will be noted that the pointer at the outer edge of the small window lines up with a marked tooth on the dial itself. It will be found that the dial and backplate can be moved so that the backplate pointer will mesh between teeth at points equi-distant from marked tooth in either direction.

(d) If by checking as in paragraph (c), the dial is found not properly adjusted, it will be necessary to separate the backplate from the dial far enough to bring

the two gears out of mesh and then re-mesh the two parts until the proper setting is

found. A number of trials may be required before the correct mesh is found.

## SECTION 7. POWER UNITS

### 7-1. Type 697 Table Model Power Unit

The National Type 697 Table Model Power Unit operates from 115 or 230 volts A.C., 50 or 60 cycles, to provide 240 volts at 70 milliamperes D.C. and 6.2 volts at 3.2 amperes A.C. The circuit diagram of this unit is shown in Figure 9. Output voltages for both A and B supply are available at a four prong socket for convenient connection of the receiver power plug. Section 7-3 shows typical operating voltages and currents when used with the HRO-5A1 Radio Receiver. The Type 697 Power Unit consists of a power transformer, glass Type 80 rectifier tube, and a single section condenser-input filter. B- is connected to the Power Unit Chassis. The Power Unit for rack mounting is designated as SPU-697.

### 7-2. Type 686S Table Model Power Unit

The National Type 686S Table Model Power Unit operates from a 6 volt D.C. supply to provide approximately 165 volts at 45 milliamperes D.C. Battery clips are provided for convenient connection to a 6 volt storage battery or similar source of power. Output voltages for both A and B supply are available at a four prong socket for convenient connection of the receiver

power plug. Figure 10 shows the schematic wiring diagram. Section 7-3 shows typical operating voltages and currents when used with the HRO-5A1 Radio Receiver. The 686S Power Unit consists of a vibrapack and a single section condenser-input filter. The vibrapack uses a 6X5 (or OZ4) type rectifier tube and a vibrator. It should be noted that B- is not connected to the Power Unit chassis; A- is connected to the chassis. The National Type SPU-686S Power Unit is the rack-mounted model.

### 7-3. Typical Operating Conditions for Power Units

The following table shows typical operating currents and voltages of the 697, 686S Power Units when used with HRO Series Receivers:

VARIABLE	697	686S
Primary Voltage	115 or 230 VAC	6V DC
Frequency	50/60 cps	0
Heater Voltage	6.2 VAC	6V DC
Heater Current	3.4 Amp. AC	3 Amp.
B Voltage	240 VDC	165V DC
B Milliamperes	70 DC	45 DC
Line Current	.65 Amp.	6.3 Amp.
Power Consumption	70 Watts	38 Watts

## SECTION 8

## PARTS LIST

Symbol	Function	Type	Rating
<b>CAPACITORS</b>			
C-1A	First R.F. Amplifier Tuning	Air	225 mmf. max.
C-1B	Second R.F. Amplifier Tuning	Air	225 mmf. max.
C-1C	First Detector Tuning	Air	225 mmf. max.
C-1D	H.F. Oscillator Tuning	Air	225 mmf. max.
C-2	First I.F. Grid Filter	Paper	.01 mfd., 600 VDCW
C-3	First Detector Cathode Bypass	Paper	.1 mfd., 400 VDCW
C-4	Second R.F. Plate Bypass	Paper	.1 mfd., 600 VDCW
C-5	H.F. Oscillator Screen Bypass	Paper	.1 mfd., 600 VDCW
C-6	First I.F. Cathode Bypass	Paper	.1 mfd., 400 VDCW

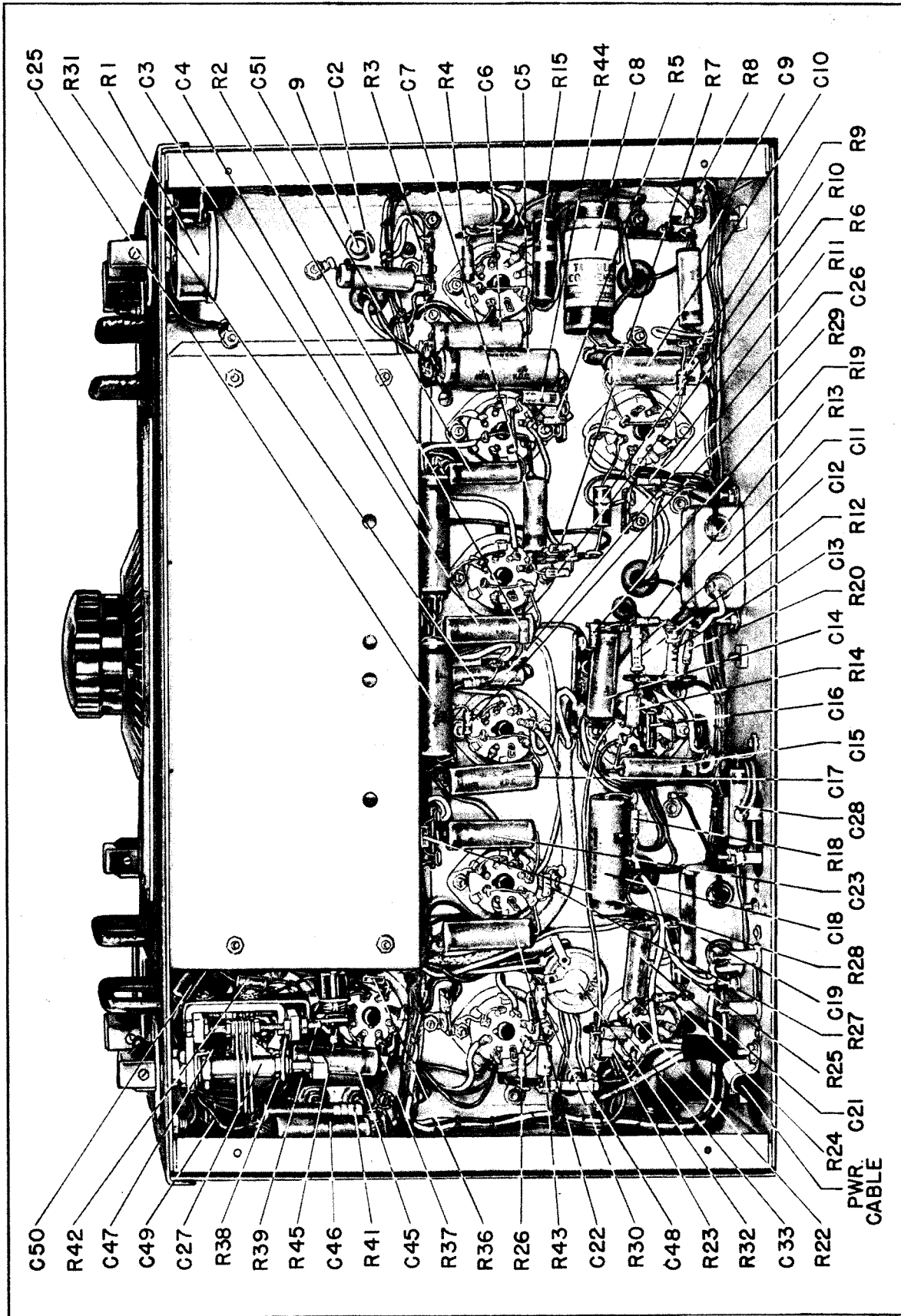

Figure No. 7. Bottom View of Receiver

## SECTION 8

## PARTS LIST (Continued)

Symbol	Function	Type	Rating
<b>CAPACITORS (Continued)</b>			
C-7	H.F. Oscillator Coupling	Paper	.01 mfd., 600 VDCW
C-8	First & Second I.F. Plate Bypass	Paper	.25 mfd., 600 VDCW
C-9	Second I.F. Grid Filter	Paper	.01 mfd., 600 VDCW
C-10	Second I.F. Cathode Bypass	Paper	.1 mfd., 400 VDCW
C-11	Second Detector Cathode Bypass	Elec.	10 mfd., 50 VDCW
C-12	Second Detector Filter	Ceramic	100 mmf., 500 VDCW
C-13	Second Detector Filter	Ceramic	270 mmf., 500 VDCW
C-14	V-7 to V-10 Coupling	Paper	.1 mfd., 400 VDCW
C-15	Second Detector Bypass	Paper	.01 mfd., 600 VDCW
C-16	Second Audio Plate Bypass	Mica	470 mmf., 500 VDCW
C-17	Second R.F. Cathode Bypass	Paper	.1 mfd., 400 VDCW
C-18	V-7 to V-9 Coupling	Paper	.1 mfd., 600 VDCW
C-19	Audio Output Cathode Bypass	Elec.	10 mfd., 50 VDCW
C-20	Not Used		
C-21	C.W. Oscillator Screen Bypass	Paper	.01 mfd., 600 VDCW
C-22	First R.F. Cathode Bypass	Paper	.1 mfd., 400 VDCW
C-23	V-1, V-2, V-5 and V-6 Screen Bypass	Paper	.1 mfd., 400 VDCW
C-24	First R.F. Grid Filter	Paper	.01 mfd., 600 VDCW
C-25	First R.F. Plate Bypass	Paper	.1 mfd., 600 VDCW
C-26	Second R.F. Grid Filter	Paper	.01 mfd., 600 VDCW
C-27	C.W. Oscillator Tuning	Air	30 mmf.
C-28	Audio Output Screen Bypass	Paper	.01 mfd., 600 VDCW
C-29	C.W. Oscillator Grid Coupling	Mica	.001 mfd., 500 VDCW
C-30	H.F. Oscillator Grid Coupling	Ceramic	100 mmf., 500 VDCW
C-31	Crystal Filter Bridge	Ceramic	100 mmf., 500 VDCW
C-32	Crystal Filter Bridge	Ceramic	100 mmf., 500 VDCW
C-33	V-8 to V-7 Coupling	Ceramic	2 mmf., 500 VDCW
C-34	Coil A-1 Antenna Coupling	Ceramic	39 mmf., 500 VDCW
C-35	Coil A-1 Series Padder	Mica	.0012 mfd., 500 VDCW
C-36	Coil A-4 Series Padder	Mica	.001 mfd., 500 VDCW
C-37	Coil B-4 Series Padder	Mica	.0026 mfd., 500 VDCW
C-38	Coil C-4 Series Padder	Mica	.0016 mfd., 500 VDCW
C-39	Coil D-4 Series Padder	Mica	900 mmf., 500 VDCW
C-40	Coil E-4 Series Padder	Ceramic	500 mmf., 500 VDCW
C-41	Coil F-4 Series Padder	Ceramic	350 mmf., 500 VDCW
C-42	Coil G-4 Series Padder	Ceramic	100 mmf., 500 VDCW
C-43	Coil J-4 Series Padder	Ceramic	50 mmf., 500 VDCW
C-44	H.F. Oscillator Temp. Compensating (Minus .00077 mmf./mmf./°C)	Ceramic	10 mmf., 500 VDCW
C-45	V-10 to V-11 Coupling	Paper	.1 mfd., 400 VDCW
C-46	Limiter Filter	Elec.	8 mfd., 250 VDCW
C-47	Limiter Output Coupling	Paper	.01 mfd., 600 VDCW
C-48	Audio Output Grid Filter	Ceramic	160 mmf., 500 VDCW
C-49	A.V.C. Filter	Mica	.001 mfd., 500 VDCW
C-50	A.V.C. Filter	Mica	.001 mfd., 500 VDCW
C-51	H.F. Oscillator Plate Bypass	Paper	.01 mfd., 600 VDCW

## PARTS LIST (Continued)

## SECTION 8

Symbol	Function	Type	Rating
<b>RESISTORS</b>			
R-1	R.F. Gain Control	W.W. Var.	10,000 Ohms, 1.5 W.
R-2	First Detector Cathode	Fixed	4,700 Ohms, 1/2 W.
R-3	First I.F. Grid Filter	Fixed	470,000 Ohms, 1/2 W.
R-4	First I.F. Cathode	Fixed	330/1000 Ohms, 1/2 W.
R-5	H.F. Oscillator Screen Filter	Fixed	47,000 Ohms, 1/2 W.
R-6	H.F. Oscillator Screen Filter	Fixed	100,000 Ohms, 1/2 W.
R-7	H.F. Oscillator Screen Bleeder	Fixed	100,000 Ohms, 1/2 W.
R-8	Second I.F. Grid Filter	Fixed	470,000 Ohms, 1/2 W.
R-9	Second I.F. Cathode	Fixed	330 Ohms, 1/2 W.
R-10	V-1, V-2, V-5, and V-6 Screen Filter	Fixed	15,000 Ohms, 2 W.
R-11	S-Meter Bridge	Fixed	2,200 Ohms, 1/2 W.
R-12	Second Detector Load	Fixed	470,000 Ohms, 1/2 W.
R-13	Second Detector Filter	Fixed	47,000 Ohms, 1/2 W.
R-14	Second Detector Equalizing	Fixed	220,000 Ohms, 1/2 W.
R-15	V-1, V-2, V-5, and V-6 Screen Bleeder	Fixed	27,000 Ohms, 2 W.
R-16	Not Used		
R-17	Not Used		
R-18	Second Audio Plate Load	Fixed	47,000 Ohms, 1/2 W.
R-19	A.V.C. Filter	Fixed	470,000 Ohms, 1/2 W.
R-20	Second Detector Cathode	Fixed	330 Ohms, 1/2 W.
R-21	Not Used		
R-22	C.W. Oscillator Screen Filter	Fixed	100,000 Ohms, 1/2 W.
R-23	C.W. Oscillator Plate	Fixed	220,000 Ohms, 1/2 W.
R-24	C.W. Oscillator Screen Bleeder	Fixed	100,000 Ohms, 1/2 W.
R-25	Audio Output Cathode	Fixed	330 Ohms, 2 W.
R-26	Audio Output Grid	Fixed	470,000 Ohms, 1/2 W.
R-27	First R.F. Cathode	Fixed	330 Ohms, 1/2 W.
R-28	First R.F. Grid Filter	Fixed	470,000 Ohms, 1/2 W.
R-29	Second R.F. Cathode	Fixed	330 Ohms, 1/2 W.
R-30	S-Meter Bridge	Fixed	1,800 Ohms, 1/2 W.
R-31	Second R.F. Grid Filter	Fixed	470,000 Ohms, 1/2 W.
R-32	S-Meter Zero Adjusting	W.W. Var.	1,000 Ohms, 1 W.
R-33	Audio Gain Control	Comp. Var.	500,000 Ohms, 1 W.
R-34	C.W. Oscillator Grid	Fixed	47,000 Ohms, 1/2 W.
R-35	H.F. Oscillator Grid	Fixed	22,000 Ohms, 1/2 W.
R-36	First Audio Grid	Fixed	1,000,000 Ohms, 1/2 W.
R-37	First Audio Cathode	Fixed	4,700 Ohms, 1/2 W.
R-38	Limiter Plate	Fixed	47,000 Ohms, 1/2 W.
R-39	Limiter Cathode	Fixed	47,000 Ohms, 1/2 W.
R-40	Limiter Threshold Control	W.W. Var.	10,000 Ohms, 1 W.
R-41	First Audio Plate	Fixed	47,000 Ohms, 2 W.
R-42	Limiter Plate	Fixed	220,000 Ohms, 1/2 W.
R-43	Audio Output Grid	Fixed	220,000 Ohms, 1/2 W.
R-44	H.F. Oscillator Plate	Fixed	22,000 Ohms, 1 W.
R-45	First Audio Plate Dropping	Fixed	33,000 Ohms, 1/2 W.
R-46	Second Detector Cathode	Fixed	470 Ohms, 1/2 W.

## SECTION 8

## PARTS LIST (Continued)

Symbol	Function	Type	Rating
<b>TRANSFORMERS</b>			
T-1	Crystal Filter		456 K.C.
T-2	Second I.F. Transformer	Air Tuned	456 K.C.
T-3	Second Detector Transformer	Air Tuned	456 K.C.
T-4	C.W. Oscillator Transformer	Air Tuned	456 K.C.
<b>VACUUM TUBES</b>			
V-1	First R.F. Amplifier	6K7	
V-2	Second R.F. Amplifier	6K7	
V-3	First Detector	6J7	
V-4	High Frequency Oscillator	6J7	
V-5	First I.F. Amplifier	6K7	
V-6	Second I.F. Amplifier	6K7	
V-7	Second Detector, A.V.C., Second Audio	6SQ7	
V-8	C.W. Oscillator	6J7	
V-9	Audio Output	6V6GT/G	
V-10	First Audio Amplifier	6J5	
V-11	Noise Limiter	6H6	
<b>SWITCHES</b>			
X-1	B+ Switch	Toggle	S.P.S.T.
X-2	C.W. Oscillator Switch	Toggle	S.P.S.T.
X-3	A.V.C. Switch	Toggle	S.P.D.T.
X-4	S-Meter Switch	Toggle	S.P.S.T.
X-5	Crystal Selectivity Switch	Rotary	Two Gang 6 Position
<b>TYPE 697 POWER UNIT</b>			
C-112, C-113, C-114	Filter Capacitor	Elec.	8+8+8 Mfd., 475 VDCW
L-102	Filter Choke	Potted	17 Henry
P-101	Power Cord and Plug		
S-101	115-230 Volt Switch	Toggle	D.P.D.T.
S-102	Power Switch	Toggle	S.P.S.T.
T-101	Power Transformer	Potted	
V-101	Rectifier Tube	80	
<b>TYPE 686S POWER UNIT</b>			
C-101	Filter Capacitor	Mica	500 Mfd., 15 VDCW
C-102, C-103	Filter Capacitor	Elec.	8+8 Mfd., 475 VDCW
E-101	Vibrapack		6.3 VDC Input
F-101	Fuse	3AG	10 Amperes
L-201	Filter Choke	Potted	17 Henry
L-202	Hash Choke	Potted	
S-101	Power Switch	Toggle	S.P.S.T.
V-101	Rectifier Tube	6X5	



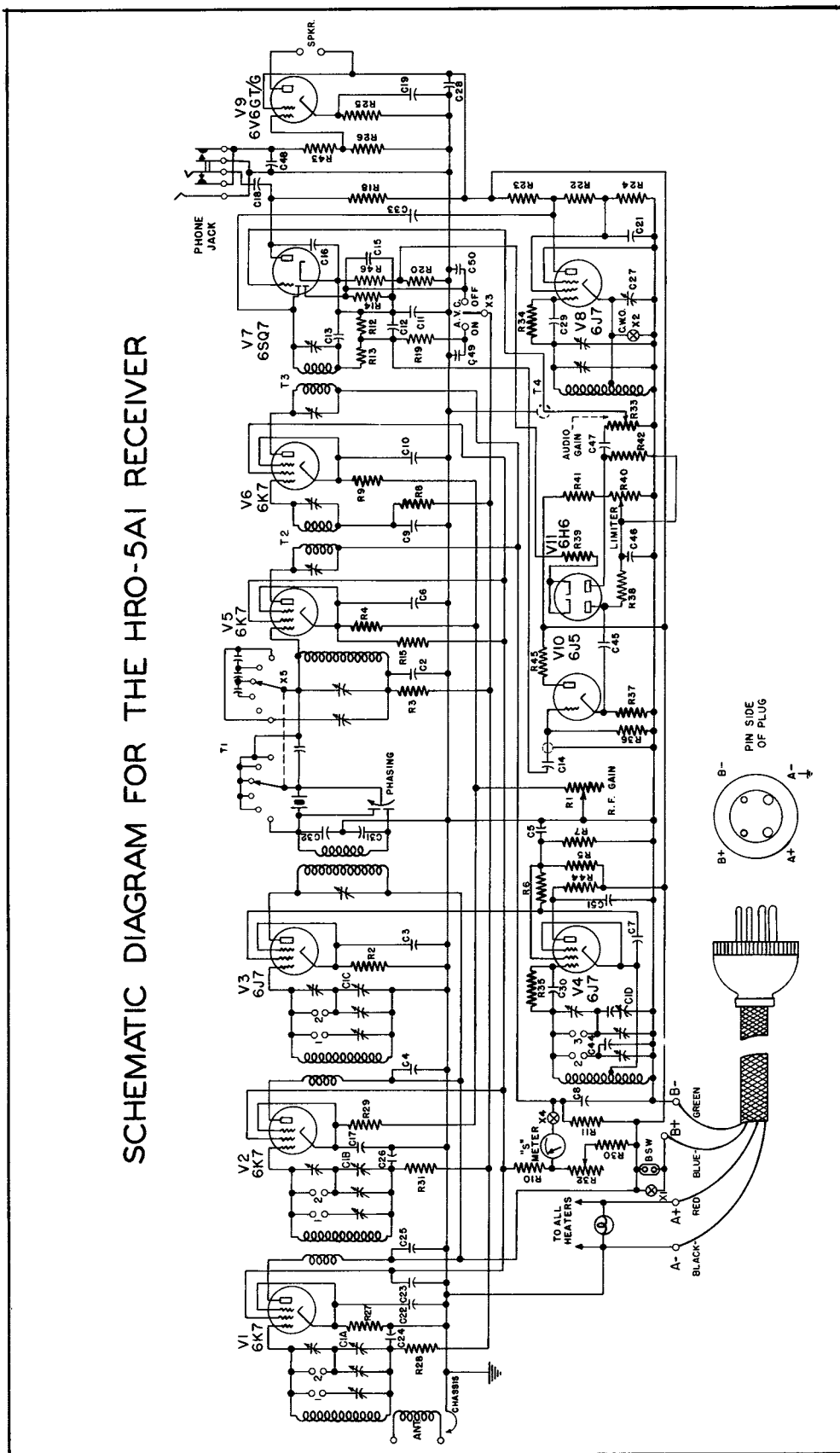

Figure No. 8. Schematic Diagram -- HRO-5A1 Radio Receiver

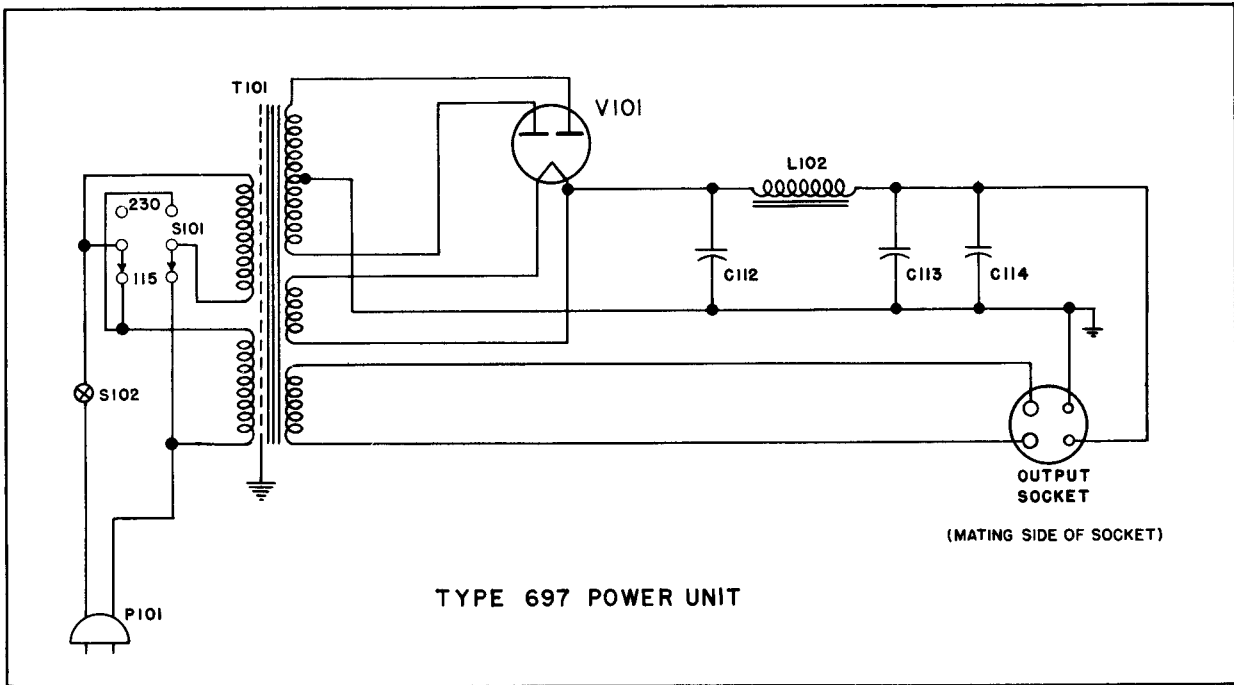

Figure No. 9. Schematic Diagram -- 697 Power Unit

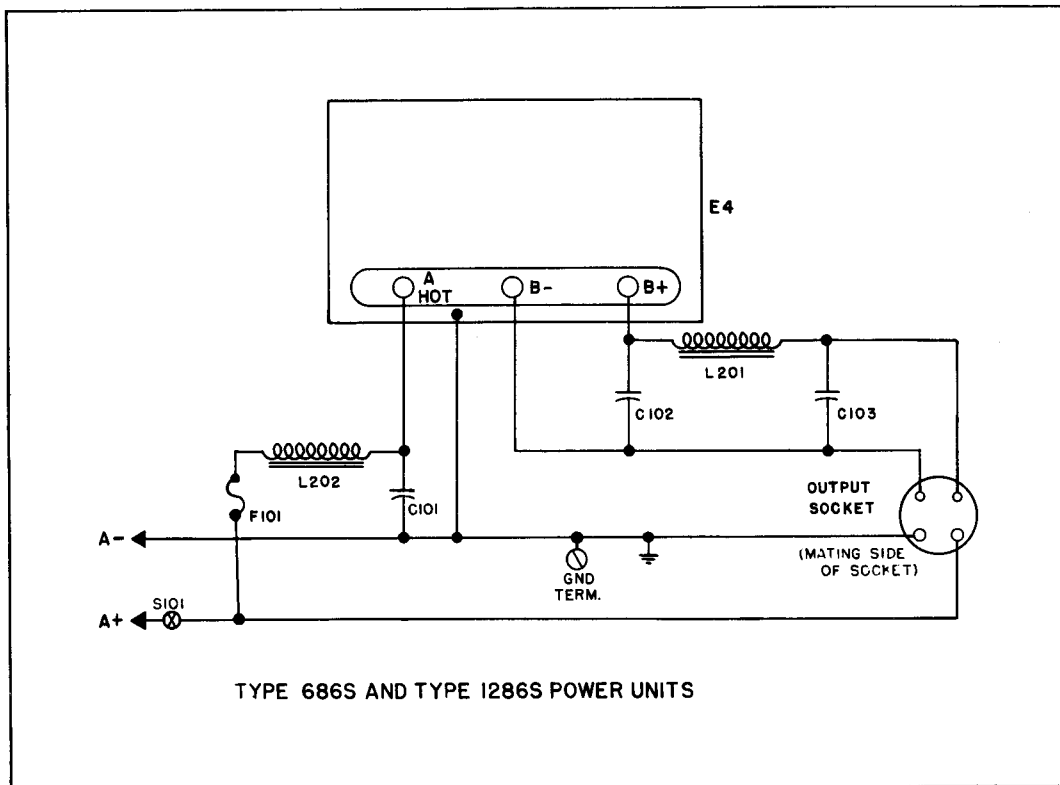

Figure No. 10. Schematic Diagram -- 686S Power Unit

# THE NATIONAL HRO-5A1 RECEIVER

## *Price List*

HRO-5TA1 Receiver, table mounting black finish, complete with tubes, crystal filter, noise limiter, and A,B,C,D, coil sets.

HRO-5RA1 Receiver, same as above but mounted on a  $\frac{1}{8}$ " steel standard rack panel  $10\frac{1}{2}$ " high.

697 Power Unit, table mounting, 115 and 230 volt, 50/60 cycle operation.

SPU-697 Power Unit, same as above but mounted on  $5\frac{1}{4}$ " high rack panel.

686S Power Unit, table mounting, 6 volt battery operated vibrapack.

MCS Table Model 8" PM dynamic loudspeaker with matching transformer.

RFSH Loudspeaker, same as above but mounted on  $8\frac{3}{4}$ " high rack panel.

SPC Combination Unit, an installation consisting of a power unit, coil container and 8" PM dynamic loudspeaker mounted on a single rack panel  $15\frac{3}{4}$ " high.

MRR Mounting Rack, a standard 19" panel width table rack with a panel capacity  $24\frac{1}{2}$ " high. Trim strips included.

*Prices on Application*



**National Co., Inc., Malden, Mass., U.S.A.**



**NATIONAL COMPANY, INC.**  
**MALDEN, MASS.**  
**U. S. A.**