

OPERATION AND MAINTENANCE

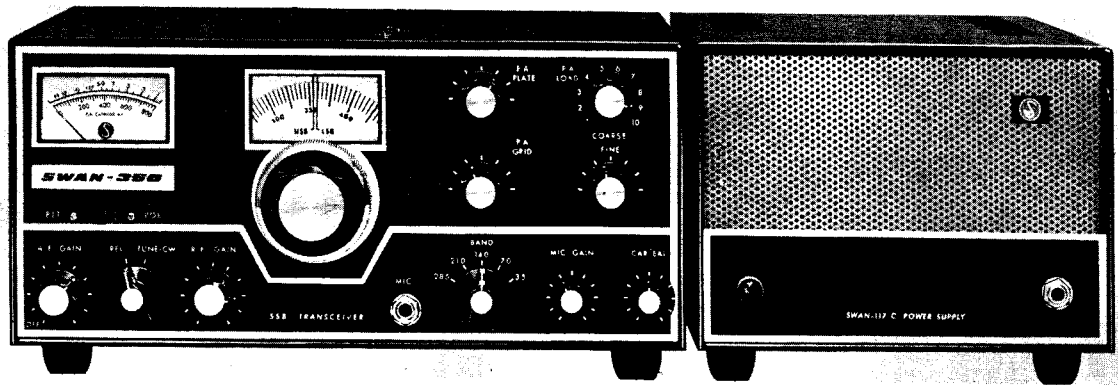

SWAN MODEL 350

Scanned by:
Laszlo I. Morocz, KF4PV
kf4pv@lmorocz.com

 **SWAN**
ELECTRONICS CORP.
Oceanside, California

1. Terms of Use

As far as I know, this manual is for obsolete equipment whose manufacturer has gone out of business and has allowed the copyrights to lapse. If not, the copyright holder should e-mail me at kf4pv@lmorocz.com. I claim copyright on all material I derived from copyright-lapsed material. I give permission for anyone to copy, distribute, incorporate and otherwise use this electronic manual as long as it and any derived materials are made available **free of charge only**. They may not be used for any commercial purposes whatsoever. They may be freely redistributed in any format, **as long as there is NO CHARGE of any sort** (including but not limited to covering the cost of distribution, media, duplication, etc., electronic or otherwise). These manuals are provided on an "as-is" basis as a public service. It is therefore the responsibility of users of the manuals to make sure that the information is accurate and applicable for their situations. Under no circumstances will users hold me responsible for damage or injuries caused by inaccuracies in the manuals. This manual may not be redistributed unless the notice is included in its entirety. Downloading or using the manuals indicates consent to these terms. If you do not consent to these terms, do not download or use the manuals.

2. History

I bought a used Swan 350 for \$125.00 at the 1984 Charlotte, NC Hamfest. This included the mobile power supply and manual. The Swan was my Novice rig and remained my main station until 1993 when I bought an ICOM-728. It's been my spare rig ever since. Its main use has been as an SSB station. The VFO stability (or lack thereof), slow switching speed and duty-cycle limitations preclude most digital modes, and I'm much more comfortable with CW on a rig with a tighter IF. But on SSB, boy, does it shine! With my Shure 254 crystal mike plugged in, I can routinely expect compliments on the audio quality from around the world.

The manual was in bad shape when I got the rig, and has been getting worse. The pages are soaked with oil and coffee, the staples have rusted and the paper is disintegrating. I decided to scan it into a digital form after I bought a scanner this year. Doug Hall, KF4KL, put me onto the method of converting scanned images to PDF files using ImageMagick. So I started scanning in the pages, estimating that it'd take me 2-3 weeks. Boy, was I wrong! Turns out that with all the damage to the manual, I had to do major digital reconstruction to get a readable image. This involved deleting all the marks and stains around the text and then working on the text itself. In some cases I had to manually erase and patch in individual pixels, in others I had no choice but to hunt for the same letters elsewhere in the manual and build the words up one character at a time. But the result was worth it. I've retired the original manual and am now using the electronic version only. I know that I find it useful, and I hope that the rest of the boat anchor community will, too.

Laszlo I. Morocz, KF4PV/3
Greenbelt, MD
December 10th, 1999

OPERATION and MAINTENANCE MODEL 350 SERIES Single Sideband Transceiver

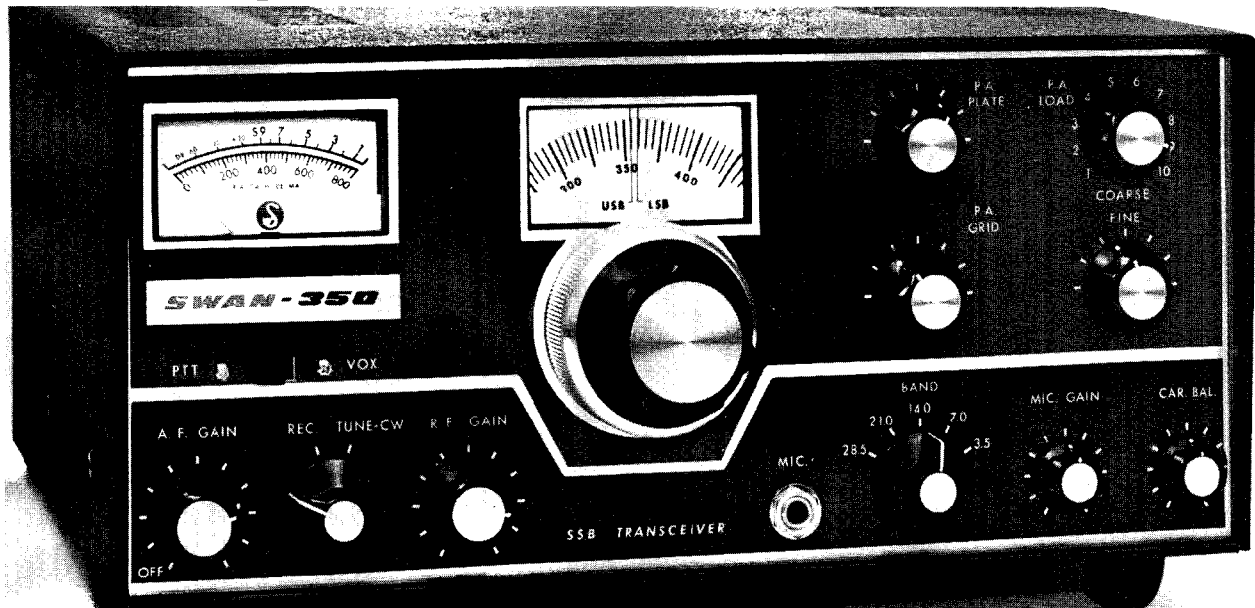

INTRODUCTION

The Swan Model 350 Single Sideband Transceiver together with its accessories and optional equipment, is designed to be used in either CW or SSB modes on all portions of the 80-, 40-, 20-, 15-, and 10-meter amateur radio bands. AM (SSB with carrier) operation is possible by zero-beating the received signal.

Model 350 generates the single sideband signal by means of a crystal lattice filter, and the transceiver operation automatically tunes the transmitter to the received frequency. Provisions are included in the transceiver for operation on the most used sideband for each frequency range, and provisions for other sideband coverage are available as an optional kit.

Basic circuitry of the single conversion design has been proven in thousands of hours of operation of the popular Swan 100 and 240 series of transceivers. Mechanical, electrical, and thermal stability are exceptionally high. All oscillators are temperature compensated and voltage regulated. Push-to-talk

operation is provided in all installations, and operation with a two-contact microphone is possible through use of the optional VOX accessory.

The basic transceiver provides coverage of all portions of the 80- through 15-meter bands, and one 500 kc portion of the 10-meter band. Complete coverage of the 10-meter band is possible through the use of an optional modification kit.

With a suitable power supply, operation may be fixed, portable, or mobile. Power input on all bands exceeds 400 watts, PEP, on single sideband, and 320 watts, dc input, on CW. The basic transceiver includes automatic gain control (AGC), automatic level control, (ALC), and grid-block CW keying.

Part I of the instruction manual covers the basic transceiver. Part II covers the recommended power supplies, Model 117C for ac operation, and Model 412 for 12-volt dc operation.

 **SWAN**
ELECTRONICS CORP.
Oceanside, California

SPECIFICATIONS

FREQUENCY RANGES

80 Meters	3.5 to 4.0 mc LSB
40 Meters	7.0 to 7.5 mc LSB
40 Meters	13.85 to 14.35 mc USB
15 Meters	21.0 to 21.5 mc USB
10 Meters	28.5 to 29.0 mc USB

Full coverage of 10-meter band possible through use of optional accessory kit.

POWER INPUT

Single Sideband Suppressed Carrier

400 watts, PEP, minimum on all bands

CW

320 watts dc input on all bands

AM (Single Sideband with Carrier)

125 watts dc input on all bands

DISTORTION

Distortion products down at least 30 db.

UNWANTED SIDEBAND SUPPRESSION

Unwanted sideband down at least 40 db

CARRIER SUPPRESSION

Carrier suppression at least 50 db

RECEIVER SENSITIVITY

Less than 0.5 microvolt at 50 ohms impedance for signal-plus-noise to noise ratio of 10 db

AUDIO OUTPUT AND RESPONSE

Audio output approximately 3 watts to 3.2 ohm load. Response essentially flat 300 to 3000 cps in both receive and transmit.

METERING

Power Amplifier cathode current 0-800 ma on transmit, S-Meter 0-70db over S9 on receive.

FRONT PANEL CONTROLS

REC-TUNE-CW, AF GAIN RF GAIN, MIC. GAIN, BANDSWITCH, CARRIER BALANCE, PA PLATE TUNE, PA GRID TUNE, PA LOAD COARSE, PA LOAD FINE, VOX-PTT SWITCH.

REAR PANEL CONTROLS AND CONNECTORS

Bias potentiometer, Grid-Block CW key jack, Jones plug power connector, Vox Connector, Antenna, S-Meter zero, SPDT relay terminal.

VACUUM TUBE COMPLEMENT

V1	6EW6 VFO Amplifier
V2	12BE6 Transmitter Mixer
V3	6GK6 Driver
V4	6HF5 Power Amplifier
V5	6HF5 Power Amplifier
V6	12BZ6 Receiver RF Amplifier
V7	12BE6 Receiver Mixer
V8	6EW6 First IF Amplifier
V9	12BA6 Second IF Amplifier
V10	12AX7 Product Detector/Receiver Audio
V11	6BN8 AGC Amplifier/Detector
V12	6GK6 Audio Output
V13	7360 Balanced Modulator
V14	12BA6 Carrier Oscillator
V15	12AX7 Mic. Amplifier/Transmit Audio
V16	OA2 Voltage Regulator

DIODE AND TRANSISTOR COMPLEMENT

Q1	2N706 Oscillator
Q2	2N706 Emitter Follower
D401	TS-2 ALC diode
D402	TS-2 ALC diode
D601	TS-2 S-Meter Delay diode
D1601	1N2974 Zener Voltage Regulator
D1602	TS-2 Relay Quietting Diode

TRANSMITTER OUTPUT

Wide-range Pi-network output matches antennas essentially resistive at 20 to 300 ohms impedance, with provisions for both coarse and fine loading adjust.

POWER REQUIREMENTS

Filaments	12.6 volts, 5.5 amp. ac or dc
Relay	12 volts dc, 250 ma
Bias	-110 volts dc, 100 ma
Medium Voltage	275 volts dc, 150 ma
High Voltage	800 volts dc, 500 ma

DIMENSIONS AND WEIGHT

Dimensions	5-1/2 in. high, 13 in. wide, 11 in. deep.
Weight	17-1/4 lb.

A. CIRCUIT THEORY

GENERAL DISCUSSION

The Swan 350 transceiver provides single sideband, suppressed carrier transceive operation, and generates the single sideband signal by means of a crystal lattice filter. To permit a logical discussion of this mode of operation, certain definitions are necessary. In a normal AM signal, (double sideband with carrier), a radio frequency signal is modulated with an audio frequency signal. This is considered by many to be merely a case of varying the amplitude of the carrier at an audio rate. In fact, however, there are actually sideband frequencies generated, which are the results of mixing the RF and the AF signals. These sidebands are the sum of, and the difference between the two heterodyned signals. For detection by means of conventional diode detectors, the two sidebands are mixed with the carrier to detect and demodulate the audio intelligence. This is an inefficient means of transmission, and permits only approximately 25 percent of the full transmitted power to be used to transmit intelligence. There are other attendant drawbacks, also. The bandwidth of the transmission is approximately 6 kc, while the actual demodulated audio is only approximately 3 kc. The result is very limited use of the frequency band, and over half of the allotted range is unusable due to the heterodynes, interference, and congestion.

In the single sideband, suppressed carrier mode of transmission, only one sideband of the RF and AF composite signal is transmitted. The other sideband and the carrier are suppressed to a level which in effect permits using only the audio intelligence bandwidth. In addition to increasing the transmission efficiency many times over, single sideband permits an effective doubling of the use of the frequency range.

It must be remembered that in the single sideband, suppressed carrier mode of transmitting, the unwanted sideband and carrier are only suppressed, not entirely eliminated. Thus, with a transmitted signal from a transmitter with 40 db sideband suppression, the other or unwanted sideband will be present, and will be transmitted, but its level will be 40 db below the wanted sideband. When this signal is received at a level of 20 db over S9, the unwanted sideband will be present at a level of approximately S5. The same is true of carrier suppression. With carrier suppression of 50 db, and a signal level of 20 db over S9, carrier will be present at a level of approximately S3 to S4.

In the Model 350 transceiver, the single sideband suppressed carrier signal is generated by the

crystal lattice filter method. For details, refer to the schematic diagram, and to Figures 1 and 2.

SIGNAL GENERATION

In the TRANSMIT position, or when the push-to-talk switch on the microphone is pressed, the transmitter portion of the transceiver is activated, and it generates a single sideband, suppressed carrier signal in the following manner. Carrier is generated by V14 Carrier Oscillator, which is a Pierce oscillator with the crystal operating in parallel resonance. This stage operates in both the transmit and receive modes. When transmitting, the RF output of the oscillator is injected into the control grid of the Balanced Modulator, V13. This balanced modulator is a beam deflection tube, and operates similar to a cathode ray tube in that the electron beam from the cathode is deflected to one output plate or the other by the charge appearing on the deflection plates. The RF energy fed to the control grid of the balanced modulator appears on both plates of the output, in the absence of audio signals to the deflection plates. The two output plates feed the carrier to Transformer Z1301 in push-pull, and the two RF signals cancel each other out in the output of Z1301. The deflection plate reference voltages are adjusted by means of the carrier balance control so that with no audio input, the RF being fed to the output plates will cancel out, and the output from Z1301 will be zero. Audio signals from the Microphone Amplifier, V15, are superimposed on one deflection plate, thereby unbalancing the modulator, and the two sidebands resulting from the sum and difference frequencies of the audio and carrier appear as a double sideband, suppressed carrier signal in the output of Transformer Z1301. The carrier suppression is approximately 50 db.

The double sideband, suppressed carrier signal is then coupled to the crystal filter, which suppresses one sideband, and permits the other sideband to be fed to the First IF Amplifier, V8. The carrier frequency crystal and the filter crystals are selected so that on 40 and 80 meters the sideband signal is generated at a carrier frequency of 5172.8 kc, and this signal falls within the bandpass of the filter such that the lower sideband will be attenuated by at least 40 db. Refer to Figure 3. With the optional other sideband crystal, the carrier crystal frequency will be 5176.8 kc, and this positions the double sideband signal on the other side of the filter response curve, attenuating the upper sideband by at least 40 db. In the single conversion mixing process, these sidebands become inverted.

I. MODEL 350 TRANSCEIVER

A. Circuit Theory (Cont)

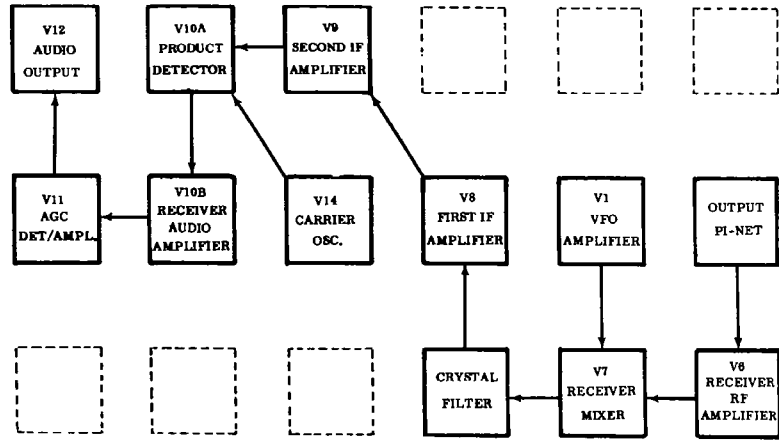

FIGURE 1 BLOCK DIAGRAM, RECEIVE

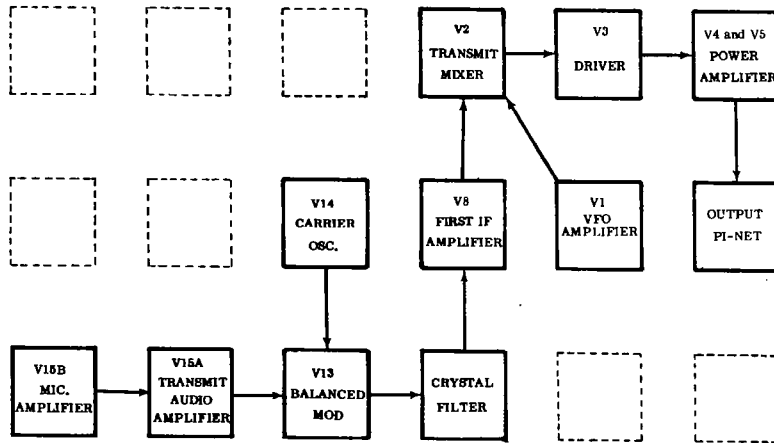

FIGURE 2 BLOCK DIAGRAM, TRANSMIT

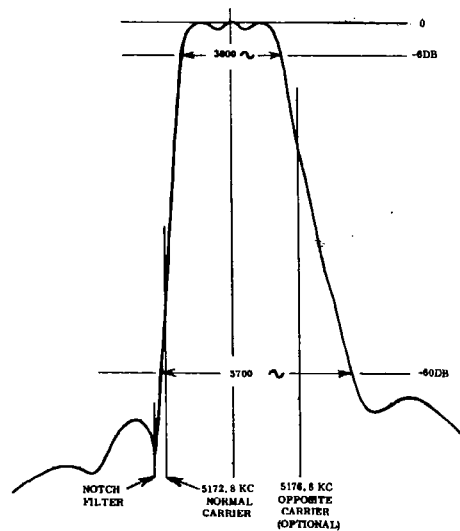

FIGURE 3 CRYSTAL FILTER RESPONSE CHARACTERISTICS (TYPICAL)

SIGNAL GENERATION (cont)

On 20, 15, and 10 meters, where operation is generally on upper sideband, the signal is generated with the same carrier crystal used in generating the lower sideband on 40 and 80 meters. The five crystal filter used in the transceiver results in an improved response characteristic on the low frequency end of the bandpass, and advantage is taken of this effect to provide better sideband suppression on the most used sideband for each frequency range.

Q1, the VFO 2N706 Oscillator, operates in the common base configuration as a Colpitts oscillator. Capacitors, C1712, C1713, C1714, and C1715, which are used for temperature compensation, are switched in series with the main tuning capacitor C1706 across the coil being used for the particular band. Capacitors C1701, C1710, and C1703 form a voltage divider, and effectively tap the oscillator across only about 10 percent of the oscillator tank circuit to give exceptional stability. Q2, the Emitter Follower is used primarily for impedance matching purposes, not to increase stability. The extremely good regulation achieved through using the Zener diode regulator D1601 across the bias supply voltage, also contributes to the stability. Bandswitching is accomplished by changing the tank circuit coil, and double slug tuning adjustments are used to set the low and high ends of the tuning range. Although no variable frequency oscillator will approach "rock" stability, the VFO in the Model 350 exhibits extremely good stability after the initial warm-up period. Drift from a cold start should not exceed 1 kc for the first hour on 80-, 40-, and 20-meter bands, and 2 kc on 10 and 15 meters. After the initial warm-up period, drift will be negligible.

The single sideband, suppressed carrier signal from the First IF Amplifier is fed to the Transmitter Mixer, V2, where signals from the VFO Amplifier are mixed, and the resultant signal at the final transmitted frequency is amplified through the Transmitter Mixer, the Driver, V3, and the Power Amplifiers, V4 and V5. The signal from the VFO Amplifier is initiated in the transistorized VFO-Emitter Follower circuit Q1, Q2. The signal from the VFO is routed to the VFO Amplifier, and on 40 and 80 meters, is subtractively mixed with the single sideband signal from the IF Amplifier to result in LSB operation. On 20, 15, and 10 meters, the frequencies are additively mixed, resulting in output on the opposite sideband.

When in TRANSMIT, the gain of the First IF

Amplifier is controlled through the Automatic Level Control network D401-D402, etc., to control the gain of the stage in response to the average input power to the Power Amplifiers. This ALC system will compensate for any extremely strong input signals, but does not completely eliminate the necessity of proper adjustment of the Mic. Gain Control. Although this feature will prevent the transmitter from flat-topping and spurious emissions, considerable distortion may occur if the Mic. Gain. Control is not properly adjusted. Refer to Operating Instructions.

TUNE AND CW OPERATION

Normally, the frequency of the carrier oscillator is approximately 300 cps outside the passband of the crystal lattice filter. In TUNE position, to enable the transmitter to be tuned to the maximum power output condition, the frequency of the carrier oscillator is moved approximately 500 cps to place it well within the passband of the crystal lattice filter. At the same time, one deflection plate of the balanced modulator is grounded, unbalancing the modulator and allowing full carrier input for tuning purposes. A similar procedure is followed for CW to allow full carrier output during CW operation. During CW operation, the cathode of V15A is opened from ground, cutting off the tube. This allows CW operation with no danger of pickup of audio through an open microphone. Attempts to operate on CW by keying the microphone jack, and inserting carrier, are not recommended.

RECEIVE

In RECEIVE position, or at any time when the transmitter is not in TRANSMIT, all circuits used in transmitting are disabled through the relay controlled circuits, K1, K2. The relays are energized for transmitting and de-energized for receiving. Relay K2, when de-energized, allows signals from the transmitting tank circuit and antenna to be fed to the Receiver RF Amplifier, V6, where they are amplified and then fed to the control grid of the Receiver Mixer, V7. The local oscillator signal from the VFO Amplifier is now used to heterodyne the received frequency to the IF frequency, either upper or lower sideband. All IF amplification is accomplished at this frequency, nominally 5174.5 kc, through V8 and V9 IF amplifiers. In the Product Detector V10A, the IF frequency is heterodyned with carrier frequency generated by Carrier Oscillator, V14, to result in detection of the same sideband used to generate the transmitted signal. It is thus not possible for the transceiver to properly receive a signal on any frequency other than

I MODEL 350 TRANSCEIVER

A. Circuit Theory (Cont)

RECEIVE (cont)

that to which the transmitter is tuned, nor to detect the wrong sideband. This simple single conversion design results in an extremely stable signal, and an image response down more than 80 db.

FREQUENCY CALIBRATION

Frequency calibration of the Model 350 is in increments of 5 kc. Two red lines are marked on the tuning dial to indicate the proper tuning for USB and LSB. All five frequency bands are covered in 500 kc segments. On 80-, 40, 15, and 10 meters, the dial reads directly in kilocycles above the lower frequency limit of the band. The calibrations must be added to the low frequency to arrive at the correct frequency. On 20 meters the red scale must be used to read the direct increment on this range.

Because of the extreme frequency coverage of the various bands, sometimes it is difficult to achieve perfect tracking across the entire 500 kc segment. On 80 meters, for example, the calibration is exact at 3800 and 4000 kc, but may be a few kc off at 3500 kc. If the optional calibrator kit is not installed, it is essential that some external means of monitoring exact frequency be available if the extreme lower portions of the bands, particularly the band edges, are to be used.

TRANSMIT AND RECEIVE SWITCHING

All transmit and receive switching is performed through K1, the transmit-receive switching relay. In TRANSMIT position, only those tubes that operate in the transmit mode are operative, all others being biased to cutoff through the relay contacts. In the RECEIVE position, with the relay de-energized, the tubes that are normally used only in transmitting are cut off in the same manner. Relay K2, which, when de-energized, feeds signals from the output pi-network to the receiver, also controls the S-Meter switching circuit. In the transmit position the meter indicates the combined cathode current of the two power amplifiers. In the receive position, it indicates the voltage across R902 in the cathode of the Second IF Amplifier, V9, which is inversely proportional to the AGC voltage used to control the gain of the tube. Thus, the meter reads left to right on transmit, and right to left on receive.

POWER RATING

The Swan 350 is capable of 400 watts, PEP in-

put under steady state two-tone test conditions, when operated with any of the recommended power supplies. The peak envelope power, when voice modulated, is considerably more, typically 500 watts, or more.

Recommended power supplies produce a no-load plate voltage of approximately 925 volts. Under TUNE conditions, or CW operation, this voltage may drop to as little as 720 volts. Under steady state two tone modulation, the voltage will drop to approximately 750 volts. If the power amplifier idling current is 50 ma, and the two-tone current, just before flat-topping, is 375 ma, the peak two-tone current will be 560 ma. Under these conditions the PEP input will be 750 volts times 560 ma = 420 watts. Under voice modulation, because the average power is considerably less, the power amplifier plate and screen voltages will be maintained higher, even during voice peaks, by the power supply filter capacitors. Peak voice plate current will therefore also be higher than with two-tone test conditions. Under typical operating conditions, peak plate current before flat-topping will be 625 ma at 800 volts, to result in an input of 500 watts, PEP. Readings of cathode current will not reflect this 500 watt power input, however, because of the damping in the cathode current meter. The meter damping is such that the meter is unable to respond to variations of cathode current in the audible range. Cathode current readings under normal voice input should not exceed approximately 150 to 200 ma.

POWER AMPLIFIER PLATE DISSIPATION

There is often a misunderstanding about the plate dissipation of tubes operated as AB₁ amplifiers under voice modulation. In the Swan 350¹, while in the transmit position, and with no modulation, the plate voltage will be 890 volts, the plate current 50 ma, and the power input will be 44.5 watts.

Authorities agree that the average voice power is 10 to 20 db below peak voice power. Normally some peak clipping in the power amplifier can be tolerated, and a peak-to-average ratio of only 6 db may sometimes occur. Under such a condition, the average power input will be 125 watts, and plate current will be about 156 ma. With an average power amplifier efficiency of 55 percent, plate dissipation will be 57 watts, or 28.5 watts per tube. The 6HF5 is rated at 28 watts, continuous duty cycle, in normal TV service. Thus it can be seen that under normal operating conditions, the power amplifier tubes in the Swan 350 are not being driven very hard. Only during tuneup is there any need to limit the length of time the unit is held in TUNE position to about 30 seconds at a time.

GENERAL

The Swan 350 transceiver has been designed to provide the utmost in ease of operation, stability, versatility, and enjoyment. Maximum enjoyment from your Swan will depend to a great extent on the installation. For fixed station or portable use, operation with the Model 117C power supply provides a compact arrangement with maximum ease of operation. All switching is performed in the transceiver. For mobile installations, the Model 412 supply provides similar switching arrangements, and speaker output may be fed through the car broadcast receiver speaker.

POWER SUPPLY

The Swan Models 117B and 117C power supplies provide all necessary voltages required by the transceiver. The supplies come equipped with a pre-wired plug and cable, all ready for plugging into the transceiver. The Model 412 supply for mobile operation includes all necessary cables, connector plug, fuses, and installation hardware. The Jones plug for connection to the transceiver is furnished with the unit.

Power requirements for the Swan 350 are listed in the following table. Pin connections to the Jones type power connector are also listed as an aid in connecting other brands or home-brew supplies.

EXTERNAL SPEAKER CONNECTIONS

Audio output from the transceiver is provided at pin 12 of the Jones plug. The other speaker lead goes to the common chassis ground at pin 6. Output impedance is between 3 and 4 ohms. For mobile installations, the car broadcast speaker may be used, in which case a DPDT selector switch should be installed to select either the broadcast receiver or transceiver output.

JONES PLUG CONNECTIONS

	Pin	Nominal	Minimum	Maximum
High Voltage	8	800 VDC 500 MA	600 VDC Low Pwr.	1000 VDC Hi. Power
Medium Voltage	10	275 VDC 150 MA	225 VDC	325 VDC
Bias Voltage	3	-110 VDC 100 MA	-100 VDC	-130 VDC
Filament Voltage	4	12.6 V* 5.5 amp	11.5 V	14.5 V
Relay Voltage	5	12 VDC 250 MA	10VDC	14.5 VDC
*AC or DC				

MICROPHONE

The microphone input is designed for high impedance microphones only. DO NOT ATTEMPT TO USE CARBON MICROPHONES. The choice of microphone is important, for good speech quality, and should be given serious consideration. The crystal lattice filter in the transceiver provides all the restriction necessary on audio response, and further restriction in the microphone is not required. It is more important to have a microphone with a smooth, flat response throughout the speech range. The microphone plug should be a standard 1/4 in. diameter three-contact type. The tip connection is for push-to-talk relay control, the ring connector is for the microphone terminal, and the sleeve is for the common chassis ground. The manufacturer's instructions should be followed in connecting the microphone cable to the plug. With many microphones, the push-to-talk button must be pressed to make the microphone operative. For VOX operation, this feature may be disabled, if desired, by opening the microphone case and permanently connecting the contacts which control the microphone.

ANTENNA

Any of the common antenna systems designed for use on the high frequency amateur bands may be used with the Swan transceiver, provided the input impedance of the transmission line is not outside the capability of the pi-output matching network. An antenna which reflects a standing wave ratio on 50 or 75 ohm transmission line, below approximately 3:1 at the proposed operating frequency, or a system that results in a transmission line input impedance that is essentially resistive and between 20 and 300 ohms will take power from the transceiver with little difficulty. If tuned open-wire transmission line is used to excite the antenna, a suitable antenna tuner should be used between the transceiver and the antenna to provide a reasonable impedance match between the unbalanced coaxial output and the balanced open-wire line. Methods of constructing and operating such tuners are described in detail in the ARRL Antenna Handbook, and similar publications. For operation on the 75- and 40-meter bands, a simple dipole antenna, cut to resonate in the most used portion of the band, will perform satisfactorily. For operation on the 10, 15, and 20 meter bands, the efficiency of the station will be greatly increased if a good directional rotary antenna is used. Remember that even the most powerful transmitter is useless without a proper and efficient antenna system.

I MODEL 350 TRANSCEIVER

B. Installation (Cont)

MOBILE ANTENNA

Mobile antenna installations are critical, since any mobile antenna for use on the high frequency bands represents a series of compromises. Many amateurs lose the efficiency of their antenna through improper tuning. Points to remember about the mobile antenna used with the Swan 350 are:

1. The "Q" of the antenna must be as high as possible. The radiation resistance of a center or base loaded antenna will seldom exceed 20 ohms. To keep the highest "Q" possible, the loading coil must provide the required inductance with the lowest resistance. There are several commercial models which use high "Q" coils.
2. The loading coil must be capable of handling the power of the Model 350 with No over heating. In TUNE position, the power output of the transceiver can exceed 240 watts. Wide spaced, heavy wire loading coils are essential.
3. The simple field strength meter is much better for tuning the antenna than a reflected power meter or SWR bridge. The feedpoint impedance of the antenna will usually be approximately 20 ohms, or less at resonance. When fed with 50 ohm coaxial cable the mismatch will be at least 2:1, and this condition cannot be rectified through use of the SWR bridge. In fact, it is possible to tune the antenna off resonance if the only criterion used is the standing wave ratio. This lowers the efficiency of the antenna to the point of uselessness.
4. Use a grid dip meter or field strength meter to resonate the antenna at the desired operating frequency. Then tune the transmitter for maximum field strength indication, irrespective of standing wave ratio or reflected power. The overall efficiency of the antenna system will be optimum with these adjustments.

CONTROL FUNCTIONS

ON-OFF SWITCH (On AF Gain Knob)	Controls main power to the transceiver.	AF GAIN	Controls potentiometer R1201 in grid circuit of V12 AF Output, and varies the gain of the final audio output amplifier.
REC-TUNE-CW		MAIN TUNING	Controls C1706 in frequency determining tank circuit of VFO.
Receive	All voltages are applied to transceiver.	PA GRID	Controls CIA and CIB in plate tanks of transmitter mixer and driver.
Transmit (Push-to-Talk)	12 volt dc circuit through relay K1 and K2 is completed, and all tubes used only in receive are biased to cutoff.	PA TUNE	Controls C417 in pi-network to tune final power amplifier plate to resonance.
Tune - CW	All circuits for transmit are energized, as above, but one deflection plate of the balanced modulator is grounded, capacitor C1401 in the carrier oscillator is removed from ground.	PA LOAD, Fine	Controls C420 in pi-network to match impedance of output load. Tunes input to Receiver RF Amplifier.
MIC. GAIN	Controls potentiometer R1503 in the grid of V15A and controls amount of audio to the balanced modulator.	PA LOAD, Coarse	Switches in progressively more capacitance in parallel with PA Load, Fine.
CAR. BALANCE	Controls potentiometer R1305 in the balanced modulator deflection plate circuit, and permits balancing of the carrier.	MAIN BANDSWITCH	Switches, plate coils, and associated capacitors of VFO, VFO Amplifier, V1, Transmitter Mixer, V2, and Driver, V3. Also switches tank coil of pi-coupling system and associated capacitors in PA output tank.
RF GAIN	Controls variable resistor R609, common in the cathodes of V6, RF Amplifier, V8 and V9 IF Amplifiers.		

C. OPERATION

WARNING

DANGEROUS HIGH VOLTAGE IS PRESENT ON THE PLATE OF THE POWER AMPLIFIER WHENEVER THE POWER SUPPLY IS ENERGIZED. NEVER TURN POWER ON WHEN THE POWER AMPLIFIER COVER IS REMOVED. HIGH VOLTAGE IS ALSO PRESENT AT PIN EIGHT OF THE POWER PLUG.

The Swan Model 350 may be operated from 117 volts, ac, 50 to 60 cycle power with the Model 117B, Model 117C, power supply or the Model 117AC power supply. The Model 350 may be operated from a 12.6 volt dc source with the Swan Model 412 or 512 power supplies.

The following modification must be made to most Model 117 AC power supplies.

1. Disconnect the supply from the power line.
2. Remove the bottom cover from the supply.
3. Locate R6, the 1000 ohm 1/2 watt resistor on the component board. Short out this resistor with a piece of hookup wire.
4. Locate R5, the 12 ohm 1/2 watt resistor connected to the red and black diode, remove this resistor and replace with 4.7 ohm, 1/2 watt.
5. Replace the bottom cover before applying power.

Before connecting any cables to the Swan 350 perform the following steps:

1. Rotate the PA BIAS control on the rear chassis apron, fully counter clockwise.
2. Rotate the REC-TUNE-CW located on the lower left of the front panel counter clockwise to REC.
3. Rotate the AF GAIN Control counter clockwise to operate the power switch to OFF.

POWER SUPPLY AND ANTENNA CONNECTIONS

1. Connect a 50 to 75 ohm antenna to the coaxial connector on the rear chassis panel.
2. Connect the power supply cable to the Jones connector on the rear chassis apron.
3. Connect the power supply to the proper voltage source.

RECEIVE OPERATION

1. Rotate the AF GAIN Control clockwise to about the 3 o'clock position. The power switch will operate applying filament, relay, bias, medium, and 800 volt high voltage to the transceiver.
2. Wait approximately one minute to allow the tube filaments to reach operating temperature. During this period, perform the following steps:
 - (a) Rotate the REC-TUNE-CW switch to REC.
 - (b) Rotate the BANDSWITCH to desired band.
 - (c) Rotate MIC. GAIN fully counter-clockwise.
 - (d) Rotate CAR. BAL. control to the mid-scale position, with white dot on knob aligned with the long index mark on the panel.
 - (e) Preset PA PLATE control to mid-position.
 - (f) Preset PA GRID control to mid-position.
 - (g) Preset PA LOAD FINE to mid-position.
 - (h) Rotate PA LOAD COARSE to position 6.
 - (i) Set tuning dial to desired operating frequency.
 - (j) Set RF GAIN control to approximately 3 o'clock position.
3. Carefully adjust the PA GRID and the PA PLATE controls for maximum receiver noise. Note: The PA GRID control resonates the transmitter driver stages and the receiver RF amplifier plate circuit. The PA PLATE and PA LOAD controls adjust the input and output capacitors in the transmitter power amplifier final plate circuit, as well as the receiver RF amplifier grid circuit. Proper adjustment of these controls in the receive position will result in approximately resonant conditions in the transmitter stages.

C. Operation (Cont)

TRANSMITTER TUNING

CAUTION

The Model 350 covers several frequency ranges outside the amateur bands. Care must be exercised not to transmit on these frequencies.

Tuning of the transmitter is not complicated, provided the few simple steps are followed in the correct order. Do not attempt initial tuneup without first performing the procedures for Receive operation described above. The following procedures assume that the unit has been checked out in Receive position, and a high impedance push-to-talk microphone is inserted in the MIC. JACK.

1. Press Push-to-Talk to place unit in TRANSMIT, read the cathode current on the meter.
2. Carefully rotate the CAR. BAL. control on the front panel until the meter reads minimum cathode current.
3. Carefully adjust the PA BIAS control on the rear of the chassis until the meter reads 50 ma.
4. Carefully rotate the CAR. BAL. control clockwise until a slight increase in cathode current is obtained. Leave the CAR. BAL. control in full clockwise position if no cathode current is obtained through the range.
5. Adjust the PA GRID control for maximum cathode current. Adjust CAR. BAL. control as necessary to maintain this current below 200 ma. Note: The carrier is severely attenuated by the crystal filter. It is not unusual to be unable to obtain PA cathode current in excess of 200 ma. This in no way indicates that a lack of drive is available at the sideband frequencies. Much higher cathode currents will be obtained during modulation.
6. Reset the CAR. BAL. control for minimum cathode current reading. If necessary, reset the PA BIAS control for a 50 ma reading. This sets the PA resting current at the proper value for best linearity with reasonable PA power dissipation.
7. Rotate the REC-TUNE-CW to the TUNE position and immediately dip the cathode current by means of the PA PLATE control. Note: The PA PLATE control should always be adjusted for minimum meter reading. The PA LOAD control will adjust the amount of loading. CCW settings of the LOAD controls will result in lighter loading and lower minimum current readings.
8. Adjust the PA PLATE and PA LOAD for a dip in cathode current to approximately 500 milliamperes. Note: Under conditions

of lower than normal supply voltage, tubes not quite up to par, or a combination of these factors, it may not always be possible to load up to a full 500 ma, particularly on 10 meters. This is not necessarily a sign of something being radically wrong. Peak input power will still be 400 watts when the Power Amplifier is loaded to 400 ma in TUNE position, and entirely satisfactory operation will result. In other words, don't panic if your Swan 350 will not load to 500 ma at all times--it may be a combination of low supply voltage and tube condition.

9. Rotate the REC-TUNE-CW switch to REC.
10. Depress the push-to-talk button on the microphone and while talking in a normal tone of voice, slowly rotate the MIC GAIN control clockwise until the PA cathode current meter reading averages 150 to 200 ma. This setting of the MIC GAIN control will result in peak input power in excess of 400 watts. The ALC circuit will operate to limit the average cathode current near this value, so that a further increase in MIC GAIN will not appreciably increase the meter reading. The normal MIC GAIN setting, with a high impedance hand-held microphone, will be between the 9 and 12 o'clock positions.

AM OPERATION (Single Sideband With Carrier)

1. Tune up transmitter to full output on single sideband on desired frequency band as described above.
2. Rotate MIC GAIN control to full CCW.
3. With Push-to-Talk pressed, rotate CAR. BAL. control until cathode current is approximately 150 ma.
4. While talking in a normal tone of voice into the microphone, increase MIC GAIN setting until variation is just discernible on meter. This setting will result in adequate modulation with one sideband.

TUNE CW POSITION SWITCHING

In the TUNE position, the REC-TUNE-CW switch, S2, removes C1401, which is effectively in parallel across the carrier crystal Y1401, thereby raising the carrier frequency to be within the passband of the crystal filter. Switch S2 also grounds one deflection plate of the Balanced Modulator, opens the cathode of V15A, Transmit AF Amplifier, and switches the grid block keying circuit into operation for CW. If the key jack is closed, the keying circuit is not effectively in the transmit control circuits which are controlled through the relay.

D. ALIGNMENT AND TROUBLESHOOTING

GENERAL

The following procedures are given in the order performed during the factory alignment for the transceiver. For home servicing only partial alignment may be necessary. Read all procedures carefully before commencing either partial or complete alignment. See Figures 4 and 5 for component placement.

Equipment Required

1. Calibrated audio frequency signal generator, range 200 to 5000 cps.
2. 500 watt dummy load with output meter
3. Vacuum tube voltmeter
4. Walsco 2543 coil adjustment tool
5. Field strength meter
6. Calibrated RF Signal Generator

Pre-Alignment Conditions

1. Neutralizing capacitors C413 set to mid-point and C315 set to approximately 3/4 turn from full compression.
2. Peak IF transformers for maximum background noise with AF and RF gain full clockwise (either bottom or top core adjustment).
3. Loosely, couple field strength meter to C318 (off pin 9 of V4) with alligator clip on ceramic capacitor body.
4. Transmit bias potentiometer full counter-clockwise (maximum bias).

VFO AMPLIFIER PLATE CIRCUIT ALIGNMENT

With VTVM from pin 1 of V7, Receiver Mixer, to ground, on -15 volt scale, and the VFO or a calibrated RF signal generator fed to pin 1 of J6, adjust VFO Amplifier Plate coils for peak VTVM heading as follows:

Band	RF Generator Frequency (kc)	Dial Frequency (kc)	Coil
80	8,975	3,800	L104
40	12,300	7,125	L103
15	16,050	21,225	L102
10	23,325	28,500	L101

TRANSMITTER MIXER AND DRIVER PLATE CIRCUIT ALIGNMENT

1. Remove screen voltage from V4 and V5 by disconnecting orange wire to terminal strip immediately adjacent to V5 base. (A, Fig. 5).

2. Connect VTVM across R412, 4.7K resistor between pins 1 and 2 of terminal strip immediately behind bifilar coil in crystal filter range -15 volt scale. (Points B and C, Fig. 5).
3. Set PA grid tuning fully clockwise, REC-TUNE CW switch in REC. position.

Procedure:

Adjust bandswitch to band shown, and adjust coils for peak VTVM reading as follows:

Function Switch	Band	RF Gen. Freq. (kc)	Dial Freq. (kc)	Adjust
Tune*	80	9,173	4,000	L205 Z1301 C1402 L305
Tune	40	12,525	7,350	L204, L304
Tune	20	9,325	14,350	L203, L303
Tune	15	16,325	21,500	L202, L302
Tune	10	24,525	29,000	L201, L301

*Note: If VTVM and field strength meter exceed full scale reading, switch to transmit position and insert carrier with carrier balance control to keep reading on scale. Field strength meter and VTVM must both peak at same time since it is possible to tune the coils to the VFO frequency on 10 meters. Care must be taken that the coils be tuned properly.

Following the above procedures, replace orange wire to pin 1 of terminal strip adjacent to V5.

ALIGNMENT OF 5175 KC FILTER TRAP

With RF and AF gain at midscale, feed 5175 kc signal to antenna connector and adjust L602 until heterodyne disappears or S-meter reads zero.

ALIGNMENT OF 13 MC FILTER TRAP

Tune VFO to 14,325 kc, insert RF signal to antenna at 13,000 kc and tune RF generator for beat signal in speaker. Adjust L603 and L604 for minimum beat signal.

ALIGNMENT OF CRYSTAL FILTER

1. With dummy load and output meter attached tuneup transceiver on 4,000 kc, for maximum output.
2. Null out carrier with PTT pressed and set resting plate current to 50 ma with bias pot.
3. Connect AF generator to MIC JACK, adjust MIC. GAIN full CCW.

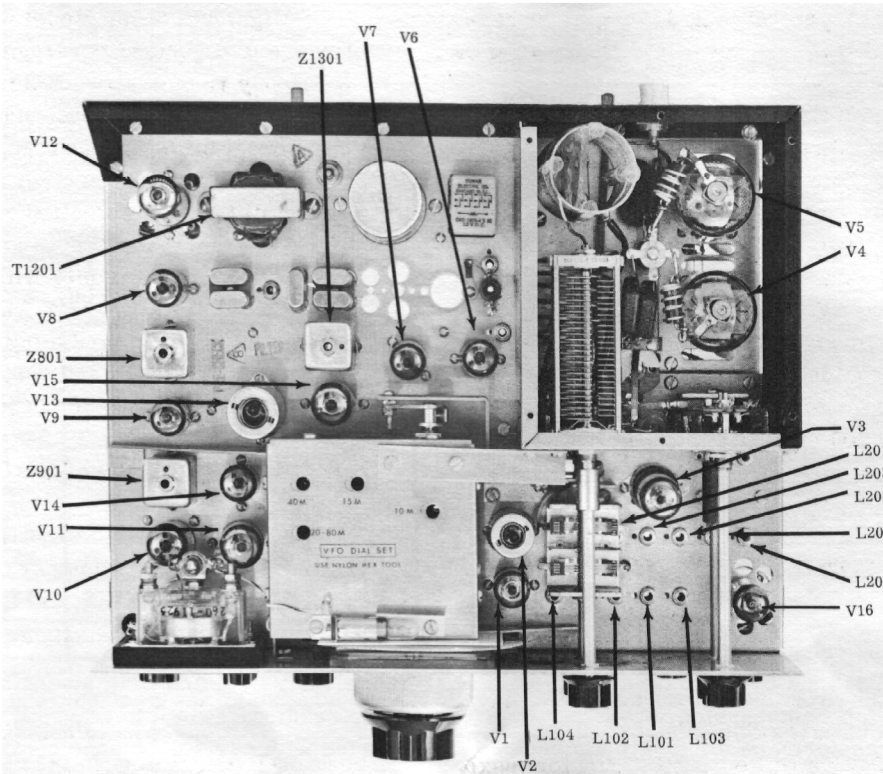

FIGURE 4 TOP VIEW, MODEL 350 TRANSCEIVER.

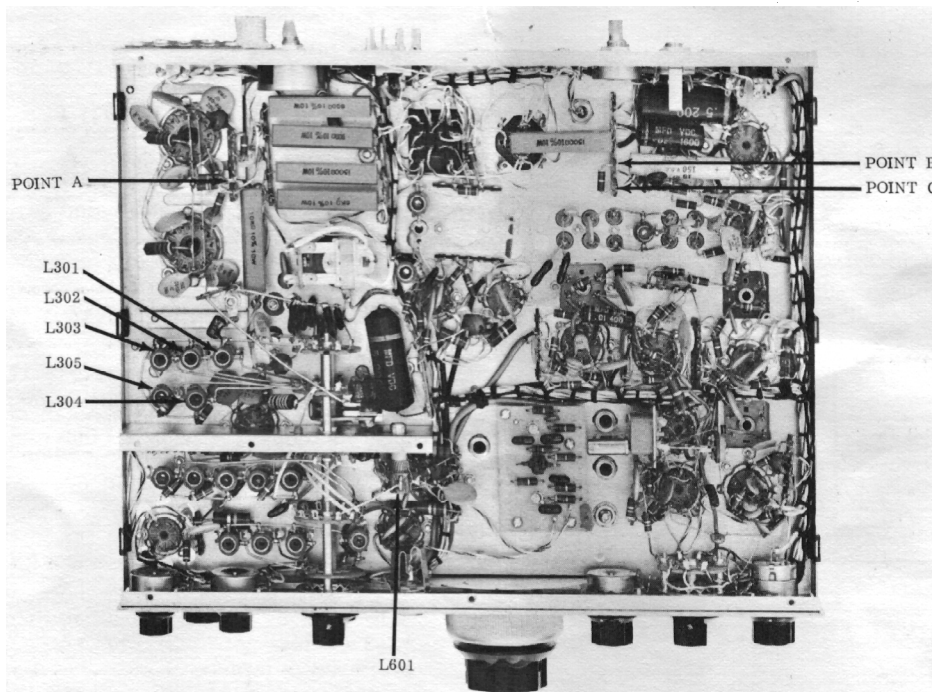

FIGURE 5 BOTTOM VIEW, MODEL 350 TRANSCEIVER

Procedure:

1. With AF generator at 1500 cps, increase MIC GAIN to result in 100 ma reading on cathode meter.
2. Readjust Z801 for maximum output meter or cathode current reading.
3. Adjust bottom slug on Z1301 for maximum output, then top slug for maximum output.
4. Adjust MIC GAIN for cathode current of 200 ma and note output meter reading.
5. Reduce AF input to zero and rotate CAR BAL for greatest deflection on meter, then adjust C1402 for meter null, then rotate capacitor to decrease capacity until meter reads 200 ma. Minimum capacity of C1402 is when silver quadrant is opposite the mounting screws.

PA NEUTRALIZATION

Procedure:

Tune transmitter to maximum output on any band, then remove all loading. Insert carrier to approximately 200 ma and peak PA GRID for maximum cathode current. Rotate PA TUNE control through range. Proper neutralization is indicated by a smooth, single dip in cathode current, with no erratic or excessive high current indication. The adjustment of neutralizing capacitors C315 and C413 must be accomplished in small increments on an adjust and try basis. C315 must be adjusted on 10 meters.

ADJUSTMENT OF L601

With transceiver tuned to 28.8 mc, and RF and AF gain at maximum, adjust L601 for maximum background noise.

S-METER ADJUSTMENT

With antenna disconnected and with RF gain fully clockwise, set R605, located on rear panel to read zero. Make sure no local signals are being received. Set RF GAIN fully CCW, meter should read 70 db over S9.

VFO ALIGNMENT

Alignment of the Model 350 VFO requires only the use of a general coverage receiver tuning the frequency ranges between 8 mc and 24 mc. Calibration of the receiver is not critical if the optional crystal calibrator in the transceiver is used for final adjustment, but the receiver must be accurate within 50 kc to permit selection of the proper 100 kc harmonic. Vernier dial set alignment may be made with the dial set knob provided with the calibrator kit. FOR MINOR FREQUENCY ADJUSTMENTS, which may be required after the initial aging period, simply turn the cabinet over and very carefully adjust the coil slug marked for the specific range.

FOR MAJOR FREQUENCY ADJUSTMENTS

Tune VFO to low end of frequency range, and locate heterodyne with general coverage receiver at frequency indicated in following table, adjust coil slug for zero beat with calibrator. Move tuning to high end of tuning range and adjust top slug for zero beat. Repeat high and low end adjustments until calibration is correct at both ends. Coil and capacitor locations are marked in the unit. On 80 meters, if calibration is exact at 3.8 and 4.0 mc, the dial will be a few kc off at 3.5 mc. If calibration is exact at 3.5 and 4.0 kc, tracking through the range will be slightly inaccurate.

Dial Frequency	Oscillator Frequency	Adjust Coil
3.5 mc	8673 kc	L1701
3.8 mc	8973 kc	L1701
4.0 mc	9173 kc	L1701
7.0 mc	12,173 kc	L1702
7.2 mc	12,373 kc	L1702
7.3 mc	12,473 kc	L1702
21.0 mc	15,827 kc	L1703
21.25 mc	16,077 kc	L1703
21.45 mc	16,277 kc	L1703
28.5 mc	23,327 kc	L1704
29.0 mc	23,827 kc	L1704

I MODEL 350 TRANSCEIVER
D. Alignment and Troubleshooting (Cont)

TROUBLESHOOTING GUIDE	
DEFECT	POSSIBLE CAUSE
PA IDLING CURRENT UNSTABLE	<ol style="list-style-type: none"> 1. Defective 6HF5 2. Defective Bias Potentiometer 3. Defective Bias Supply
INABILITY TO LOAD TO 500 MA (SEE PAGE 10)	<ol style="list-style-type: none"> 1. PA Grid Improperly Tuned 2. Bandswitch Improperly Set 3. Antenna Not Resonant at Frequency 4. Defective Transmission Line 5. Defective Mobile Antenna Coil 6. V2, V3, V4, V5 Defective 7. R407 or R408 Defective
INSUFFICIENT CARRIER SUPPRESSION	<ol style="list-style-type: none"> 1. Carrier Balance Control Improperly Adjusted. 2. Defective 7360 Balanced Modulator 3. Carrier Oscillator Frequency Incorrect.
INSUFFICIENT SIDEBAND SUPPRESSION	<ol style="list-style-type: none"> 1. Excessive MIC. Gain 2. Incorrect PA Load Adjustment 3. Carrier Oscillator Frequency Incorrect 4. Crystal Filter Mismatched
MICROPHONICS IN TRANSMITTER	<ol style="list-style-type: none"> 1. Excessive Mic. Gain 2. V13, V14, V15 Defective
MICROPHONICS IN RECEIVER	<ol style="list-style-type: none"> 1. Z901 Improperly Tuned 2. V14, V10, V9, V8, V7, or V6 Defective
LOW RECEIVER SENSITIVITY	<ol style="list-style-type: none"> 1. PA Grid, Plate, or Load Improperly Set 2. Bandswitch Improperly Set 3. K2 Back Contacts Defective 4. V6, V7, V8, V9, V10, V11, V12 Defective.

TUBE TYPE	VOLTAGE CHART											
	PIN NO.											
	1	2	3	4	5	6	7	8	9	10	11	12
V1 6EW6	R	0	.75	6.3	0	130	130	0				
	T	0	.75	6.3	0	125	125	0				
V2 12BE6	R	-90	0	12.6	0	245	240	-90				
	T	-2.0	0	12.6	0	245	100	0				
V3 6GK6	R	0	-30	0	6.3	0	0	255	255	0		
	T	0	-6.0	0	6.3	0	0	250	250	0		
V4 6HF5	R	6.3	-	-	0	-75	0	-	0	-75	0	0
	T	6.3	-	-	.12	-75	215	-	215	-75	.12	0
V5 6HF5	R	12.6	-	-	0	-75	0	-	0	-75	0	6.3
	T	12.6	-	-	.12	-75	215	-	215	-75	.12	6.3
V6 12BZ6	R	0	2.8	0	6.3	230	140	0				
	T	-85	0	0	6.3	230	0	0				
V7 12BE6	R	-3.0	0	12.6	0	235	75	0				
	T	-3.0	0	12.6	0	210	0	-75				
V8 6EW6	R	0	2.6	12.6	6.3	230	130	0				
	T	0.2	0.5	12.6	6.3	205	120	0				
V9 12BA6	R	0	0	12.6	0	230	105	3.2				
	T	-75	0	12.6	0	220	0	0				
V10 12AX7	R	155	-0.6	0	12.6	0	160	0	1.5	6.3		
	T	100	-75	0	12.6	0	155	0	1.5	6.3		
V11 6BN8	R	0.2	22	0.2	12.6	6.3	0	200	6	70		
	T	0	21	0	12.6	6.3	-70	100	3	40		
V12 6GK6	R	0	-6	-	12.6	6.3	-	240	230	0		
	T	0	-21	-	12.6	6.3	-	250	220	0		
V13 7360	R	0	245	-90	6.3	0	225	225	25	25		
	T	0	85	0	6.3	0	135	135	23	23		
V14 12BA6	R	-7	0	0	12.6	60	100	0				
	T	-7	0	0	12.6	60	100	0				
V15 12AX7	R	95	0	0.8	-	-	70	0.2	0	0		
	T	50	0	0.3	6.3	6.3	50	0.2	0	0		
V16 OA2	R	150	-	-	-	-	150	0				
	T	150	-	-	-	-	150	0				

All Voltage Measurements Made With Simpson 260, 20 K Ohms Per Volt, Or Equivalent

E. PARTS LIST

CAPACITORS

C101	.002, 20% 1KV Disc	C418	50 10% 6 KV Disc	C1304	.002, 20% 1 KV Disc
C102	.01, +80-20%, 500V Disc	C419	Two 50 10% 6 KV Discs	C1305	.01, +80-20% 500V Disc
C103	.002, +80-20% 500V Disc	C420	410 pf P.A. Fine Load	C1306	.01, +80-20% 500V Disc
C104	.01, +80-20% 1 KV Disc	C421	Two 150, 10% 1 KV NPO Discs	C1401	50, 5% 500V Mica
C105	.01, +80-20% 500V Disc	C422	Two 150 10% 1 KV NPO Discs	C1402	6-30 pf Ceramic Trimmer
C106	50, 5% 500V Mica	C423	330,10% 500V Mica	C1403	.01 +80-20% 500V Disc
C201	.01, +80-20% 500V Disc	C424	330, 10% 500V Mica	C1501	.01, +80-20% 500V Disc
C202	40-30-10-20 Mfd. 450-450-450-25 WV Elect.	C425	330, 10% 500V Mica	C1502	.01, +80-20% 500V Disc
C203	.002, 20% 1 KV Disc	C426	330, 10% 500V Mica	C1503	220, 20% 1 KV Disc
C204	.001, 5% 500V Mica	C427	330, 10% 500V Mica	C1504	100, 20% 1 KV Disc
C205	15, 5% 500V Mica	C428	330, 10% 500V Mica	C1505	.01, +80-20% 500V Disc
C206	24, 5% 500V Mica	C429	330, 10% 500V Mica	C1701	270, 2%, SM
C207	120, 5% 500V Mica	C430	.002, 80-20% 500V Disc	C1702	.0015, 500V, disc
C208	130, 5% 500V Mica	C431	.5 10% 200V Mylar	C1703	430, 2%, SM
C290	10, 5% 500V Mica	C601	.01 +80-20% 500V Disc.	C1704	27, 5%, SM
C210	12, 5% 500V Mica	C602	.01, +80-20% 500V Disc	C1705	430, 5%, SM
C211	15, 5% 500V Mica	C603	.01, +80-20% 500V Disc	C1706	5-12 Main Tuning
C212	50, 5% 500V Mica	C604	10, 5% 500V Mica	C1707	.01, 500V, Disc
C213	3.3 pf 10% 500V Ceramic	C605	5, 10% NPO	C1708	0-8.7 Trimmer
C301	.01 +80-20% 500V Disc	C606	100, 5%, MICA	C1709	27, N220
C302	.01 +80-20% 500V Disc	C701	30, 10% 1 KV Disc	C1710	30, N220
C303	100 5% 500V Mica	C702	30, 10% 1KV Disc	C1711	10, N220
C304	100 5% 500V Mica	C703	.01 +80-20% 500V Disc	C1712	50, N150
C305	68, 5% 500V Mica	C704	220 5% 500V Mica	C1713	50, NPO
C306	15, 5% 500V Mica	C705	430 5% 500V Mica	C1714	50, N80
C307	20, 5% 500V Mica	C706	5, 10% NPO Disc	C1715	50, N150
C308	68, 5% 500V Mica	C707	5, 10% NPO Disc	C1716	.01, 500V, Disc
C309	470, 5% 500V Mica	C708	39, 10% NPO Disc	CIA-B	85 pf per section
C310	510, 5% 500V Mica	C709	.01, +80-20% 500V Disc		
C311	30, 5% 500V Mica	C801	.01, +80-20% 500V Disc	RESISTORS	
C312	680, 5% 500V Mica	C802	.01, +80-20% 500V Disc	R101	75 ohms
C313	50, 5% 500V Mica	C803	.01, +80-20% 500V Disc	R102	56 ohms
C314	91, 5% 500V Mica	C804	10, 10% 1 KV Disc	R103	47K - 1 watt
C315	1.5/20 pf Mica Trimmer	C805	.002 20% 1 KV Disc	R104	12K - 2 watt
C316	15, 5% 500V Mica	C901	.01 +80-20% 500V Disc	R201	27K
C317	68, 5%, 500V Mica	C902	.01 +80-20% 500V Disc	R202	18K - 2 watt
C318	.002, 20% 1 KV Disc	C903	.01, +80-20% 500V Disc	R203	4.7K - 1 watt
C401	.002, 20% 1 KV Disc	C904	.01, +80-20% 500V Disc	R204	6.8 K
C402	.002, 20% 1 KV Disc	C1001	1 pf 10% Ceramic	R205	4.7K
C403	.01 +80-20% 500V Disc	C1002	.01, +80-20% 500V Disc	R206	4.7 K
C404	.01, + 80-20% 500V Disc	C1003	220, 20% 1 KV Disc	R301	100 K
C405	.01, +80-20% 500V Disc	C1004	.002, 20% 1 KV Disc	R302	270K
C406	10 mf 150WV Electrolytic	C1005	.002, 20% 1 KV Disc	R303	100 ohms
C407	.01, +80-20% 500V Disc	C1006	.002, 20% 1 KV Disc	R304	10K
C408	.01, +80-20% 500V Disc	C1007	500, 10%, 500KV Disc	R305	8.2K
C409	.01, +80-20% 500V Disc	C1101	.001, 20% 1 KV Disc	R306	10K
C410	.002, 20% 1 KV Disc	C1102	.01, +80-20% 500V Disc	R401	2 Meg
C411	.002, 20% 3 KV Disc	C1103	.5, 10% 200V Mylar	R402	1K
C412	.002, 20% 3KV Disc	C1104	.001, 500V Disc	R403	100 ohms
C413	20 pf P.A. Neut. Trimmer	C1201	.002, 20% 1 KV Disc	R404	100 ohms
C414	15, 20% 3 KV Disc	C1202	220, 20% 1 KV Disc	R405	Selected
C415	270, 5% 2500V Mica	C1203	.005, 10% 1600V Mylar	R406	2K - 5% - 1/2W
C416	270, 5% 2500V Mica	C1301	.01 +80-20% 500V Disc	R407	10K - 10 watt
C417	200 pf PA Tune	C1302	220 20% 1 KV Disc	R408	4.7 - 5% - 1 watt
		C1303	.01, +80-20% 500V Disc	R409	4.7 - 5% - 1 watt

I MODEL 350 TRANSCEIVER

E. Parts List (Cont)

RESISTORS (Cont)

R410 10K Bias Pot.
 R411 10K - 1 watt
 R412 4.7K
 R413 4.7 K
 R601 1 Meg.
 R602 56 ohms
 R603 47K - 1 watt
 R604 1K
 R605 1K - S-Meter Pot.
 R606 100 ohms
 R607 470K
 R608 150K
 R609 10K RF GAIN
 R701 27K
 R702 22K - 1 watt
 R801 470 ohms
 R802 56 ohms
 R803 47K
 R804 1K
 R805 100K
 R901 47K
 R902 100 ohms
 R903 47K
 R904 1K
 R905 100K
 R906 270K
 R1001 1 Meg.
 R1002 100K
 R1003 270K
 R1004 270K
 R1005 2.7K
 R1006 100K
 R1101 470K
 R1102 1K
 R1103 47K
 R1104 27K
 R1105 270K
 R1106 120, 1w
 R1201 1 Meg. A. F. Gain Pot.
 R1202 1 Meg.
 R1203 270K
 R1301 47K
 R1302 47K
 R1303 150K
 R1304 4.7K
 R1305 5K CAR BAL. Pot.
 R1306 47K
 R1307 47K
 R1308 100K
 R1309 100K
 R1310 27K
 R1311 47K
 R1401 1 Meg.
 R1402 27K
 R1403 27K

R1404 1K
 R1501 150K
 R1502 1K
 R1503 1 Meg. MIC GAIN Pot.
 R1504 270K
 R1505 2.2 Meg.
 R1506 47K
 R1601 800 - 10 watts
 R1602 900 - 10 watts
 R1603 27K
 R1604 27K
 R1605 1.5K - 10 watts
 R1606 6K - 10 watts
 R1607 1.5K - 10 watts
 R1701 1K, 5%
 R1702 1K, 5%
 R1703 1K, 5%
 R1704 470, 5%
 R1705 2.7K
 R1706 2.7K
 R1700 470, 5%

COILS

L101 23 mc - 2 uh
 L102 23 mc - 2 uh
 L103 12 mc - 7 uh
 L104 9 mc - 4 uh
 L201 28 mc - 2 uh
 L202 21 mc - 2 uh
 L203 14 mc - 3.2 uh
 L204 7 mc - 3.6 uh
 L205 4 mc - 11 uh
 L206 RFC - 200 uh
 L301 28 mc - 2 uh
 L302 21 mc - 2 uh
 L303 14 mc - 3.2 uh
 L304 7 mc - 3.6 uh
 L305 4 mc - 11 uh
 L306 RFC - 200 uh
 L401 14 mc - 0.8 uh
 L402 4 mc - 6 uh
 L403 RFC - 1 uh
 L404 RFC - 200 uh
 L405 RFC - 17 uh
 L406 RFC - 55 uh
 L601 28 mc - 1.2 uh
 L602 5175 kc - 90 uh
 L603 13 mc, 30 uh
 L604 13 mc, 1.5 uh
 L701 RFC - 200 uh
 L1001 RFC - 200 uh
 L1706 RFC

TRANSFORMERS

Z301 Parasitic Suppressor
 Z401 Parasitic Suppressor

Z501 Parasitic Suppressor
 Z801 5175 kc I. F. Trans.
 Z901 5175 kc I. F. Trans.
 Z1301 5175 kc BAL MOD. Trans.
 T701 Bifilar Filter Coil
 T1201 A. F. Output Trans.

SWITCHES

S-1 Power On-Off Ganged
 w/ R1201 AF GAIN
 S-2 REC-TUNE-CW
 S-3 VOX PTT
 S-4 A-B-C-D-E-F-G
 Bandswitch
 S-5 PA Coarse Load

DIODES

D401 - TS-2 ALC Diode
 D402 TS-2 ALC Diode
 D601 TS-2 S-Meter Diode
 D1602 TS-2 Relay Quieting
 D1601 IN 2974RB Zener

RELAYS

K1 4PDT Relay, 12 VDC Coil
 K2 2PDT Relay, 12 VDC Coil

CRYSTALS

Y701 5175.5 KC Series Res.
 Y702 5175.5 KC Series Res.
 Y703 5173.5 KC Series Res.
 Y704 5173.5 KC Series Res.
 Y705 5173.3 KC Series Res.
 Y1401 5172.8 KC Car. Osc.

TUBES

V1 6EW6 VFO Amplifier
 V2 12BE6 Trans. Mixer
 V3 6GK6 P. A. Driver
 V4 6HF5 Power Amplifier
 V5 6HF5 Power Amplifier
 V6 12BZ6 Rec. R. F. Amp.
 V7 12BE6 Rec. Mixer
 V8 6EW6 1st I. F. Amp.
 V9 12BA6 2nd I. F. Amp.
 V10 12AX7 Prod. Det./Rec. A. F.
 V11 6BN8 AGC Amp./Rect.
 V12 6GK6 A. F. Output Amp.
 V13 7360 Bal. Mod.
 V14 12BA6 Carrier Oscillator
 V15 12AX7 Mic. Amplifier
 V16 OA2 Voltage Regulator

II POWER SUPPLIES

GENERAL

Recommended power supplies for the Swan 350 are the Model 117C ac supply, and the Model 412 dc power supply. Model 117AC power supplies may be used, providing the modifications shown in Part I, on Page 9, are made. Model 117C power supplies are provided with a power cable with Jones plug attached for plugging into the transceiver. Model 412 power supplies are manufactured with a pre-wired cable to which must be connected a Jones plug after installation of the cable through the firewall of the automobile.

MODEL 117C POWER SUPPLY

Model 117C power supply is an all solid state bridge-type power supply, with the medium voltage supply provided through the center tap of the high-voltage transformer. All components of the unit are capable of handling maximum power requirements of the transceiver under all normal operating conditions. All switching for the power supply is performed in the transceiver. See Figure 6, Schematic Diagram

MODEL 412 DC POWER SUPPLY

The Model 412 power supply is a transistorized dc-to-dc converter designed for use in systems with negative grounds only. It supplies all power requirements for mobile operation of the transceiver. The Model 412 employs an entirely new design concept to provide the highest efficiency possible in mobile use. See Figure 7 for a schematic diagram of the unit.

INSTALLATION

The Model 412 may be mounted in any convenient location within the automobile. The engine compartment, near the battery, is an excellent location, since lead length will be minimized. Make all of the connections shown in Figures 8 and 9. Hardware is provided for complete installation of the supply. The power supply should be mounted with star washers on all mounting bolts to break through the anodized finish to provide a good ground. The charging rate of the generator or alternator should not exceed 13.5 to 14.0 volts.

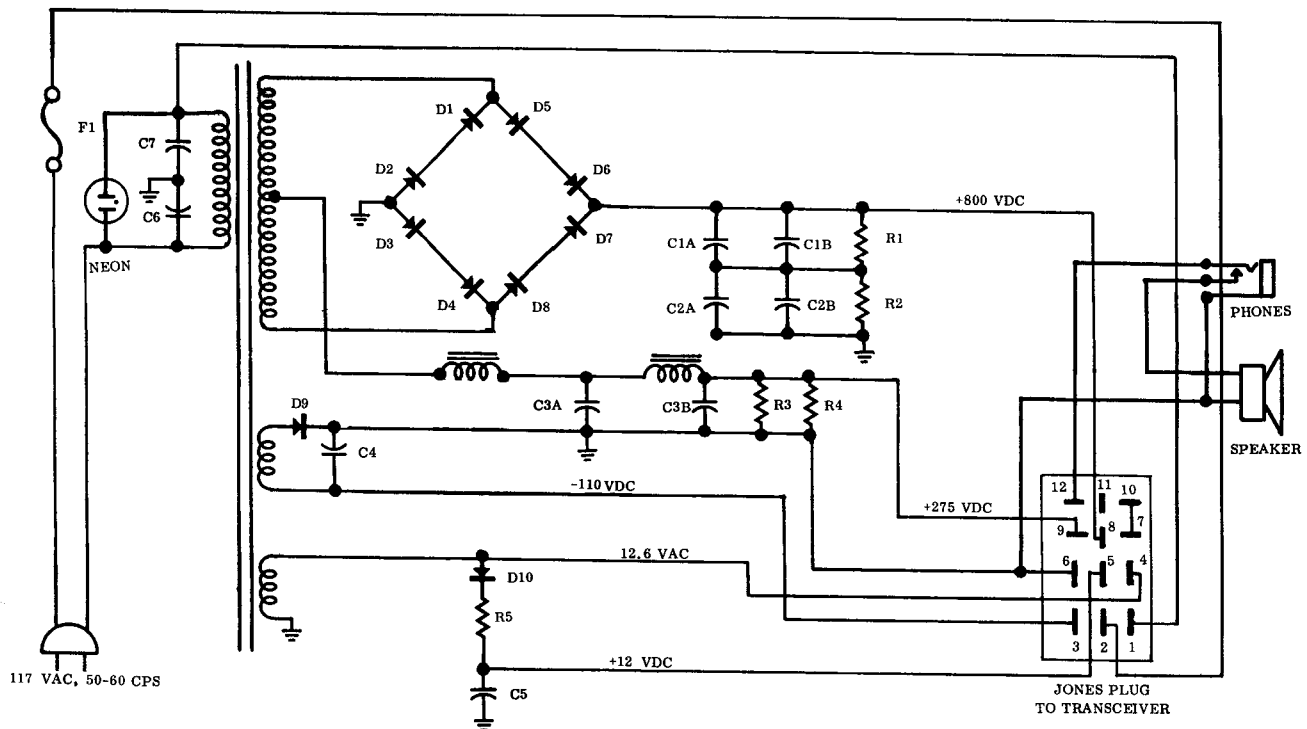

PARTS LIST

R1, R2	150K 2WATT	C3	40/40 MFD 450 WV	F1	3AB 10 A. 125 VAC
R3, R4	68K 2WATT	C4	100 MFD 150 WV	D1-8	.75 A. 600 PIV SILICON
R5	4.7 1/2 WATT	C5	100 MFD 25 WV	D9	.75 A 400 PIV SILICON
C1, C2	80/50 MFD 500WV	C6, C7	.0047 MFD 150 VAC	D10	.75 A 200 PIV SILICON

FIGURE 6 SCHEMATIC DIAGRAM, MODEL 117C POWER SUPPLY

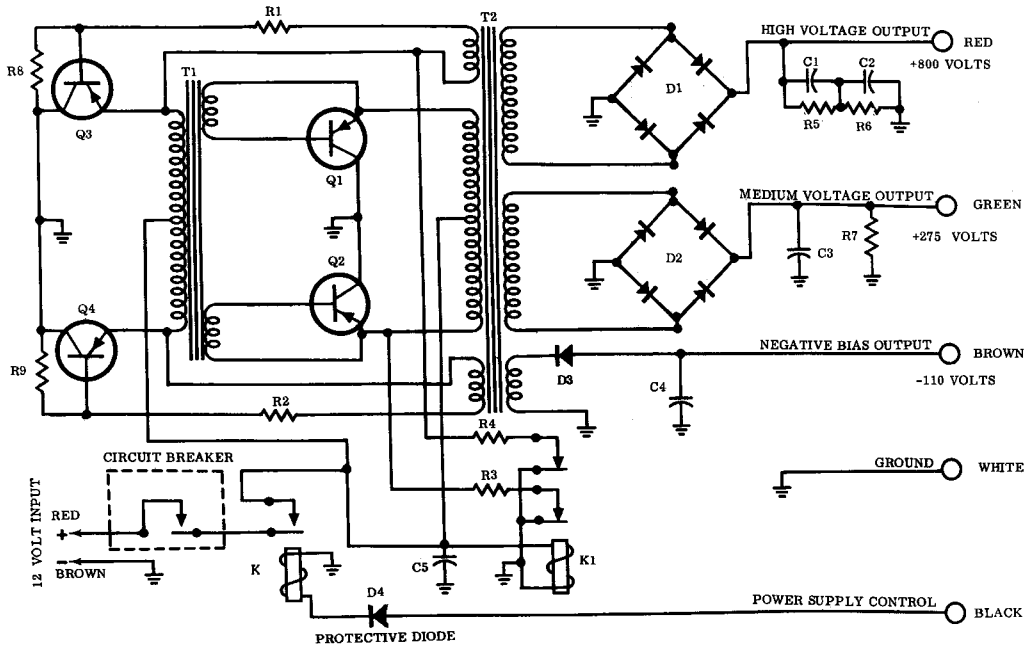

FIGURE 7 SCHEMATIC DIAGRAM, MODEL 412 DC POWER SUPPLY

PARTS LIST

Part No.	Description	Part No.	Description
R1	270 ohms, 1/2 Watt, Carbon	Q1, Q2	Swan Part No. LS605S (Special)
R2	270 ohms, 1/2 Watt, Carbon	Q3, Q4	Swan Part No. LS605B (2N555)
R3	0.50 ohm, 5 Watt, Wirewound	D1	Swan Part No. DB1K5ADI
R4	5.6 ohm, 2 Watt, Wirewound	D2, D3	Diodes, Swan Part No. D-6K-5ADI
R5, R6, R7	100K ohms, 2 Watt, Carbon	D4	Swan Part No. D-1K-5ADI
R8, R9	3.3K ohms, 1/2 Watt, Carbon	T1	Swan Part No. 4041-1
C1, C2	20MFD, 500 Volts, Electrolytic	T2	Swan Part No. 50012STI
C3	40MFD, 450 Volts, Electrolytic	K1	Swan Part No. GR11D
C4	50MFD, 150 Volts, Electrolytic	K2	Swan Part No. MAGW88DX-2
C5	2000 MFD, 15 Volts, Electrolytic	CB	Circuit Breaker, Swan Part No. L1303

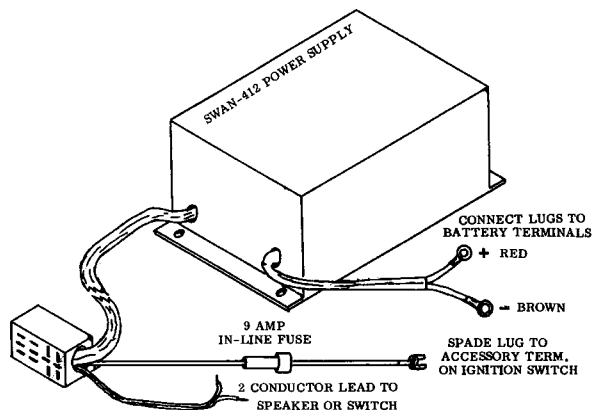

FIGURE 8 CABLING DIAGRAM

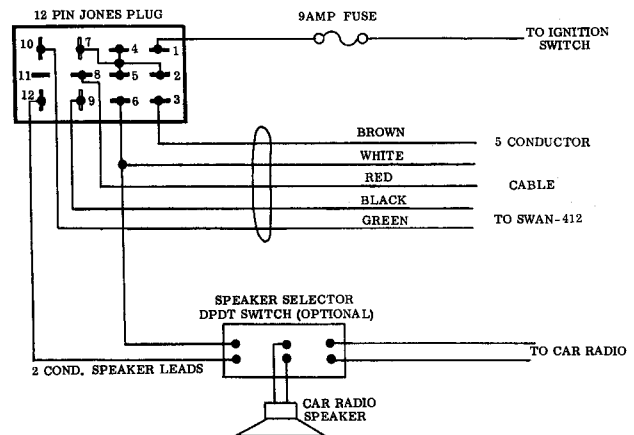
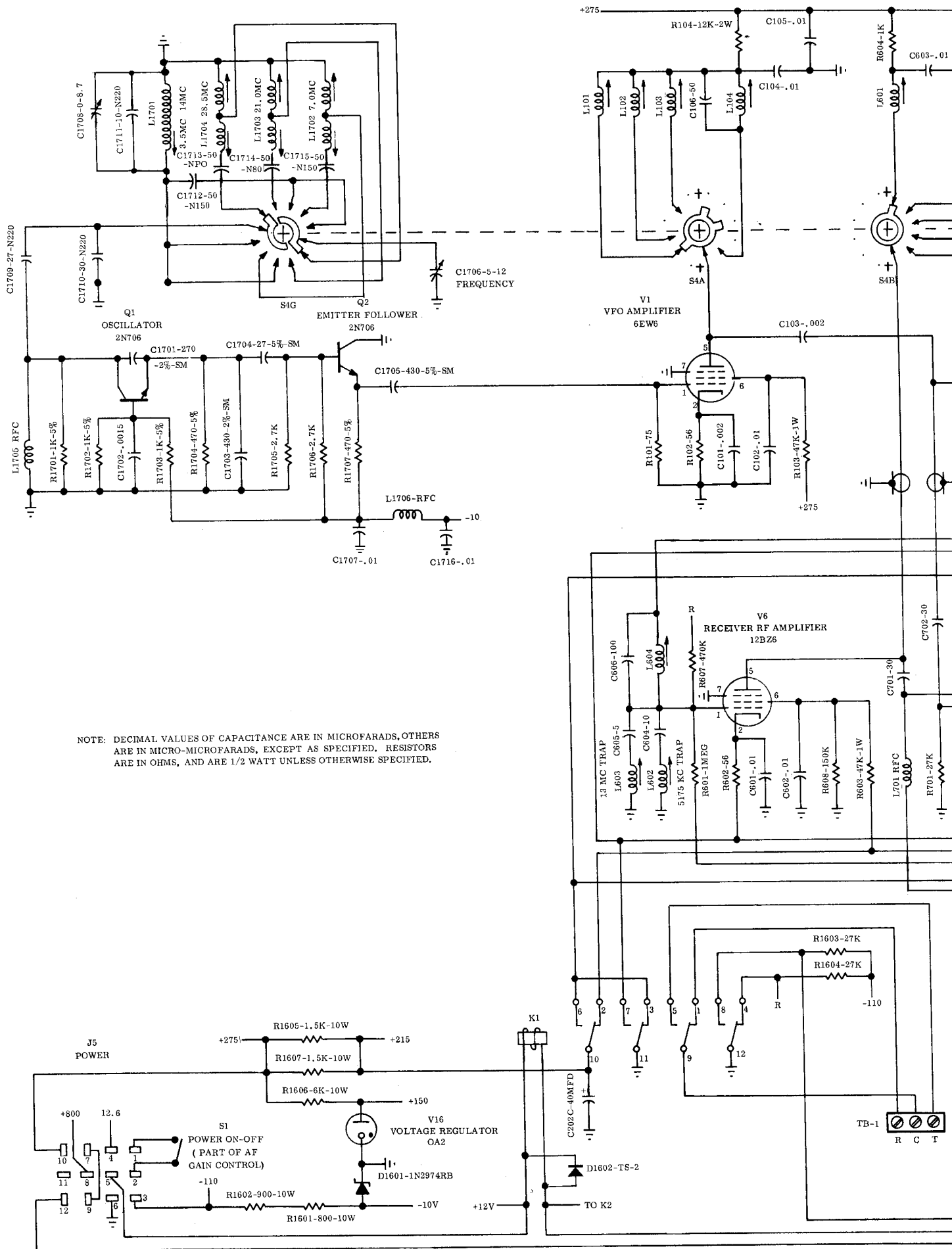
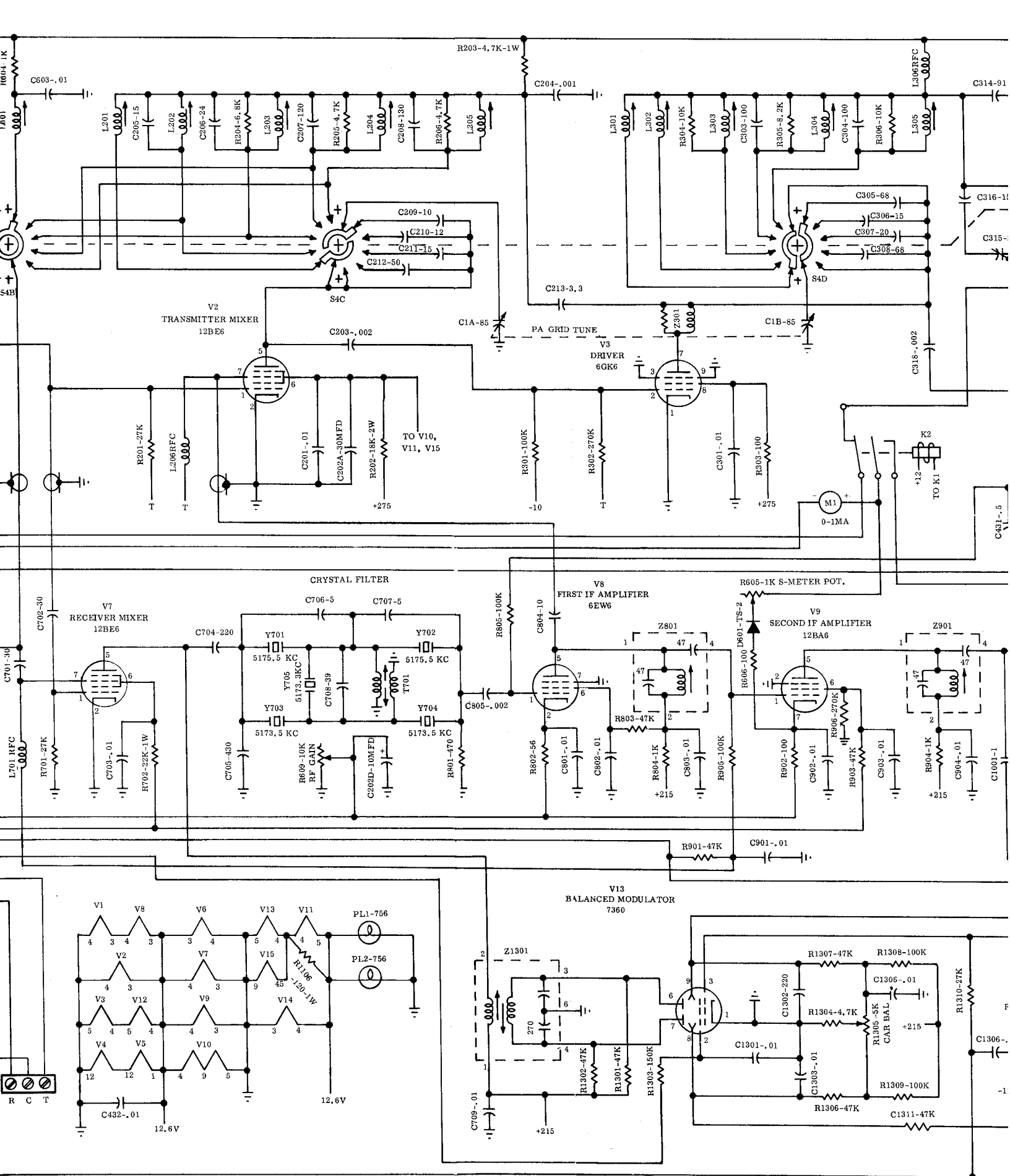
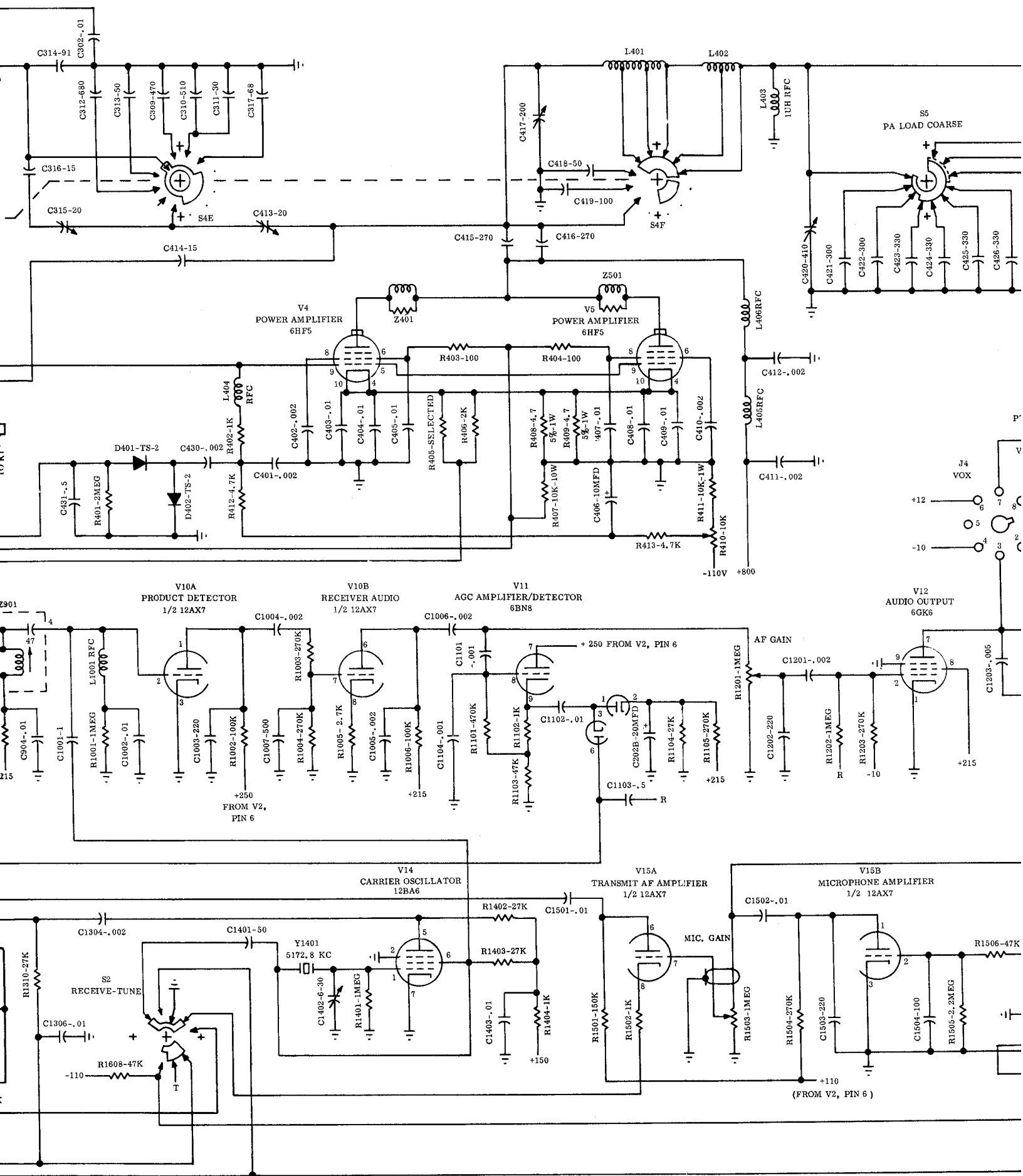

FIGURE 9 JONES PLUG WIRING DIAGRAM



NOTE: DECIMAL VALUES OF CAPACITANCE ARE IN MICROFARADS, OTHERS ARE IN MICRO-MICROFARADS, EXCEPT AS SPECIFIED. RESISTORS ARE IN OHMS, AND ARE 1/2 WATT UNLESS OTHERWISE SPECIFIED.





SCHMATIC DIAGRAM - SWAN MODEL 350 SINGLE SIDEBAND TRANSCEIVER

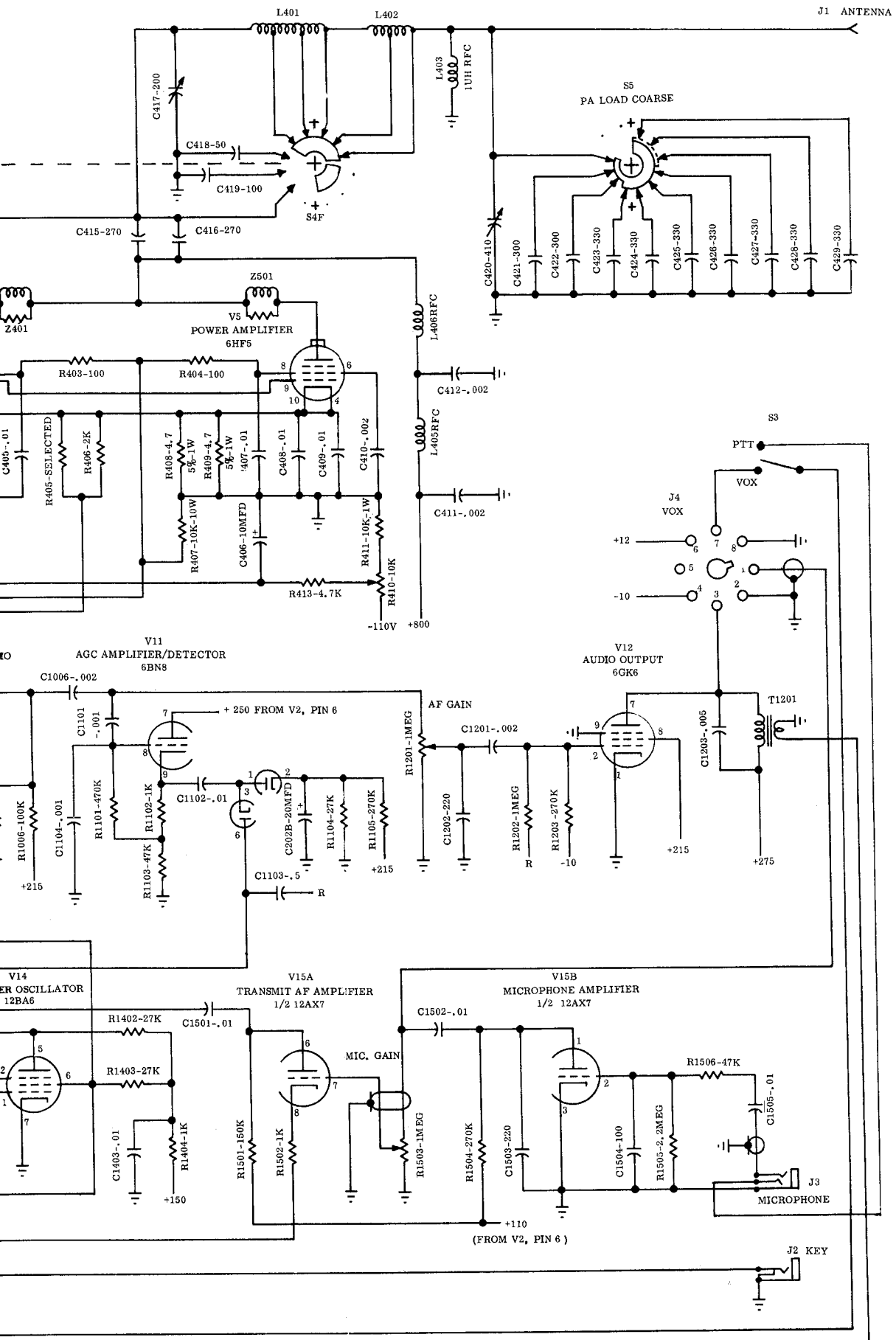

GRAM - SWAN MODEL 350 SINGLE SIDEBAND TRANSCEIVER



WARRANTY POLICY

SWAN ELECTRONICS CORPORATION WARRANTS THIS EQUIPMENT AGAINST DEFECTS IN MATERIAL OR WORKMANSHIP, EXCEPT FOR TUBES, TRANSISTORS, AND DIODES, UNDER NORMAL SERVICE FOR A PERIOD OF ONE YEAR FROM DATE OF ORIGINAL PURCHASE. THIS WARRANTY IS VALID ONLY IF THE ENCLOSED CARD IS PROPERLY FILLED IN AND MAILED TO THE FACTORY WITHIN TEN DAYS OF DATE OF PURCHASE. DO NOT SHIP TO THE FACTORY WITHOUT PRIOR AUTHORIZATION. THIS WARRANTY IS LIMITED TO REPAIRING OR REPLACING ONLY THE DEFECTIVE PARTS, AND IS NOT VALID IF THE EQUIPMENT HAS BEEN TAMPERED WITH, MISUSED, OR DAMAGED.