

# IC-M700

HF SINGLE SIDEBAND  
RADIOTELEPHONE

## INSTRUCTION MANUAL



## TABLE OF CONTENTS

SECTION	1	SPECIFICATIONS .....	1
SECTION	2	FEATURES .....	2
SECTION	3	INSTALLATION .....	3
SECTION	4	OPERATING CONTROLS.....	5
	4-1	FRONT PANEL.....	5
	4-2	REAR PANEL CONNECTIONS.....	6
SECTION	5	OPERATING INSTRUCTIONS.....	7
	5-1	HOW TO TUNE .....	7
	5-2	RECEIVING.....	9
	5-3	TRANSMITTING .....	9
	5-4	ANTENNA TUNER.....	9
	5-5	ALARM FUNCTION (OPTION).....	10
SECTION	6	CIRCUIT DESCRIPTION .....	11
SECTION	7	BLOCK DIAGRAM .....	16
SECTION	8	SCHEMATIC DIAGRAM.....	SEPARATE

## SECTION 1 SPECIFICATIONS

### GENERAL

#### Frequency Coverage:

Receive	1.6MHz ~ 23.9999MHz
Transmit	2.0MHz ~ 2.9999MHz
	4.0MHz ~ 4.9999MHz
	6.0MHz ~ 6.9999MHz
	8.0MHz ~ 8.9999MHz
	12.0MHz ~ 13.9999MHz
	16.0MHz ~ 17.9999MHz
	22.0MHz ~ 22.9999MHz

#### Frequency Control:

CPU based 100Hz step Digital PLL synthesizer.  
Independent Transmit-Receive Frequency Programmable on any band.

#### Frequency Readout:

6 digit 100Hz readout.

#### Frequency Stability:

Less than  $\pm 20$ Hz in the range of  $-30^{\circ}\text{C} \sim +60^{\circ}\text{C}$

#### Memory Channel Capacity:

48 Simplex or Semi-duplex Channels owner Programmable

#### Power Supply Requirements:

DC 13.6V  $\pm 15\%$  Negative ground Current drain 25A max.

AC power supply is available for AC operation.

#### Current Drain:

Receiving;	Stand by	1.2A
	Max. audio output	1.6A
Transmitting;	Average voice	12A
	Two tone	19A

#### Antenna Impedance:

50 ohms Unbalanced

#### Weight:

7.2kg (15.8 lb)

#### Dimensions:

112(124)mm(H) x 287(297)mm(W) x 356(376)mm(D)

( ): Shows the dimensions including projections

### TRANSMITTER

#### Emission Modes:

A3J	(J3E; USB and LSB)
A3A	(R3E; USB)
A3H	(H3E; USB)

#### RF Output Power:

150 Watts PEP.

#### Spurious Emissions:

-65dB

#### Carrier Suppression:

A3J (J3E)	40dB
A3A (R3E)	16dB $\pm 2$ dB
A3A (H3E)	3-6dB

#### Unwanted Sideband:

-55dB

#### Microphone:

600 ohms with push-to-talk switch

### RECEIVER

#### Receiving System:

Double-conversion Superheterodyne

#### Receiving Modes:

A3J (J3E; USB and LSB)
A3 (A3E, H3E)

#### Intermediate Frequencies:

1st	70.4515MHz
2nd	9.0115MHz (A3J)
	9.0100MHz (A3)

#### Sensitivity:

A3J (J3E)	12dB SINAD at $-6\text{dB}\mu$ (0.5 $\mu\text{V}$ ) input
A3 (A3E)	12dB SINAD at $3\text{dB}\mu$ (1.4 $\mu\text{V}$ ) input

#### Selectivity:

A3J (J3E)	2.3KHz/6dB, 4.2KHz/60dB
A3 (A3E)	6.0KHz/6dB, 20.0KHz/60dB

#### Spurious and Image Rejection:

70dB

#### Clarifier Range:

$\pm 150$ Hz

#### Audio Output:

5 watts (4 ohms, 10% distortion)

#### AF Output Impedance:

2 - 8 ohms

## SECTION 2 FEATURES

### 48 MEMORY CHANNELS

The IC-M700 can be operated simplex or semi-duplex covering all ship-to-shore, High Seas telephone and ship-to-ship SSB channels. Independent transmit and receive frequency programming in 100Hz steps provides complete flexibility.

A quartz-locked rock-solid synthesized tuning system provides superb stability without ever having to purchase expensive crystals or PROMs. Memories are fully programmable from the front panel keyboard, and are field programmable.

### ALL MODES

All radiotelephone channels are accessible with the IC-M700. High Seas transmission modes A3J (SSB suppressed carrier at least -40dB) and A3A (SSB reduced carrier -16dB) are provided for as well as A3H (SSB full carrier; Emulated AM).

### FULL COVERAGE

The IC-M700 features full transmit and receive coverage of all marine bands through 23.999MHz, as well as general coverage reception of UPI/AP news broadcasts, weather reports, WWV time signals, FAX weather charts and foreign broadcasts.

### SUPERIOR AUDIO

A heavy-duty speaker provides five watts of receive audio.

### OTHER FEATURES

Additional features include a wide-range clarifier, audio activated squelch (radio remains silent unless a human voice is detected), noise blanker (eliminates interference from shipboard electrical sources), modern digital readout, noise-canceling microphone, telephone-style microphone handset for privacy (optional), PLUS a heavy-duty mounting bracket. The IC-M700 is compatible with most existing antenna tuners.

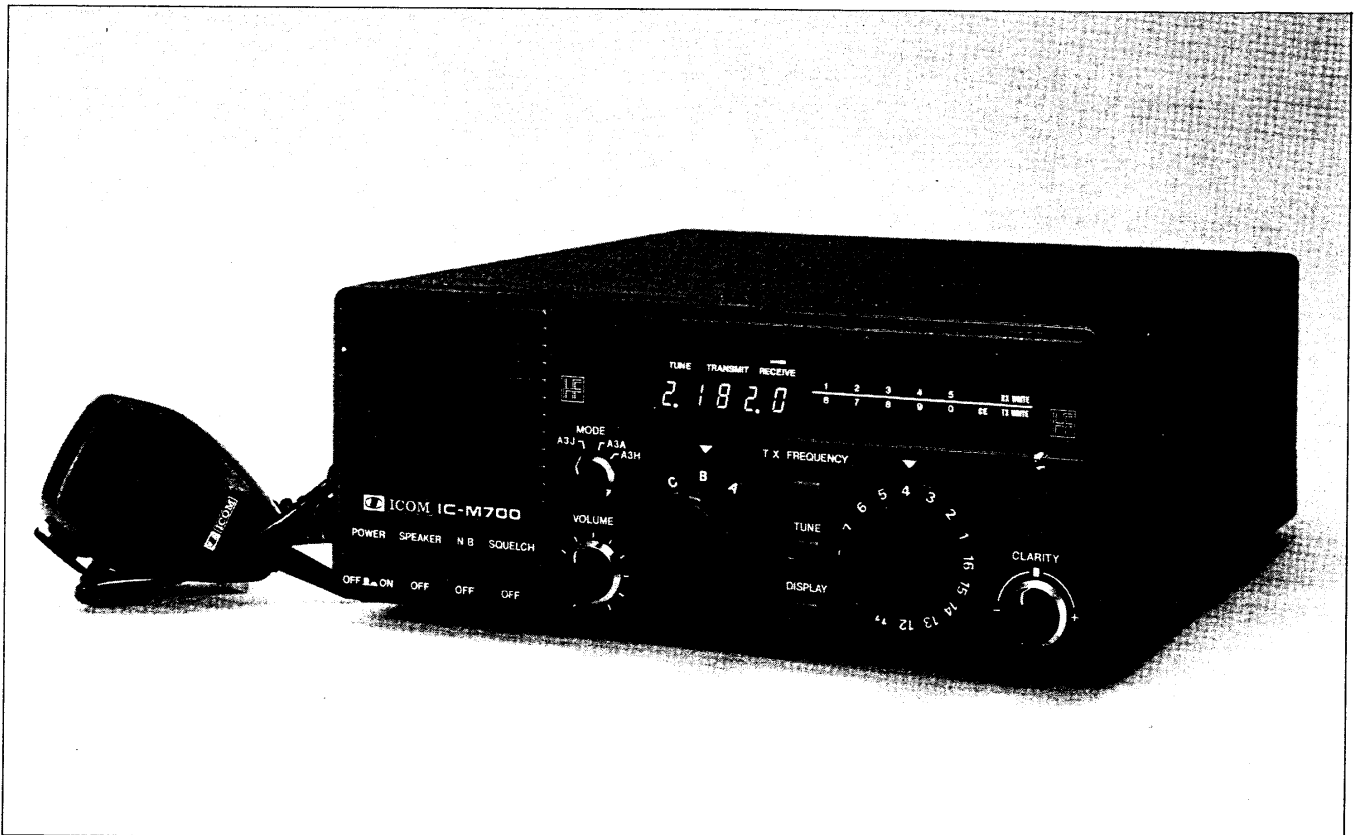

## SECTION 3 INSTALLATION

BE SURE TO READ THE FOLLOWING INSTRUCTIONS CAREFULLY BEFORE OPERATION

### 3-1 UNPACKING

Carefully remove your transceiver from the packing carton and examine it for signs of shipping damage. Should any be apparent, notify the delivering carrier or dealer immediately, stating the full extent of the damage. It is recommended you keep the shipping cartons. In the event storage, moving, or reshipment becomes necessary they will be handy. Accessory cables, plugs, etc., are packed with the transceiver. Make sure you have not overlooked anything.

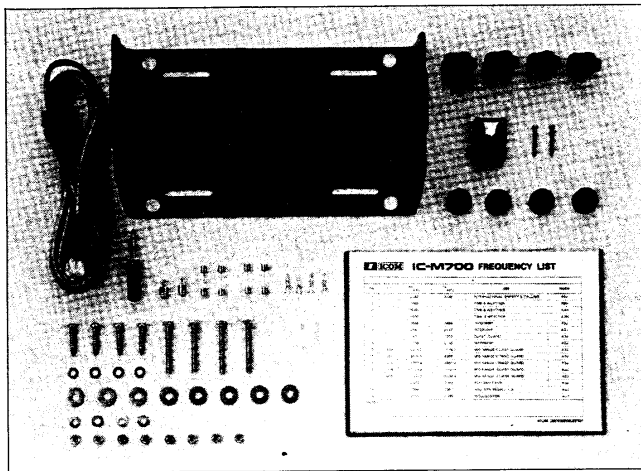

- |  |   |
|--|---|
| 1. Power Cord . . . . .                                  | 1 |
| 2. External Speaker Plug . . . . .                       | 1 |
| 3. Pin Plugs . . . . .                                   | 2 |
| 4. Fuses (30A) . . . . .                                 | 2 |
| 5. Fuses (5A) . . . . .                                  | 2 |
| 6. Antenna Tuner Connector (with contact pins) . . . . . | 1 |
| 7. Mounting Bracket . . . . .                            | 1 |
| 8. Mounting Screw Knobs . . . . .                        | 4 |
| 9. Flat Washers (M5) . . . . .                           | 4 |
| 10. Bracket Fixing Screws (Tapping Screws) . . . . .     | 4 |
| 11. Bracket Fixing Screws (Hex Head Screws) . . . . .    | 4 |
| 12. Flat Washers (M6) . . . . .                          | 8 |
| 13. Spring Washers (M6) . . . . .                        | 4 |
| 14. Bracket Fixing Screw's Nuts (M6) . . . . .           | 8 |
| 15. Microphone Hanger . . . . .                          | 1 |
| 16. Microphone Hanger Fixing Screws . . . . .            | 2 |
| 17. Frequency Chart (with Plastic Case) . . . . .        | 1 |
| 18. Rubber Cushion Feet . . . . .                        | 4 |

### 3-2 PLANNING

Select a location for your transceiver which will allow free access to the front controls, good air circulation and rear clearance for access to the fuse and cable connectors. Provide the best protection you can from direct rain or heavy seas.

Avoid long cable runs to the antenna and power source. At the same time, keep power and antenna cables as far as possible from electrical sources i.e. generators, alternators, electrical pumps, etc. Stay away from the magnetic compass with the cables, and avoid running the antenna cable near electronic instruments.

### 3-3 MOUNTING THE TRANSCEIVER

Your ICOM transceiver is supplied with a universal bracket which allows "over" or "under" mounting by placing the bracket where the unit is adequately supported when wave shock and vibration are considered.

The mounting hardware supplied will fit most installations, but should you need special mounting fasteners any good marine supply store will be able to assist you. As in any marine installation it is recommended that high quality marine fasteners be used. Try to avoid drilling new mounting holes in the bracket, as the balance of the set may be affected.

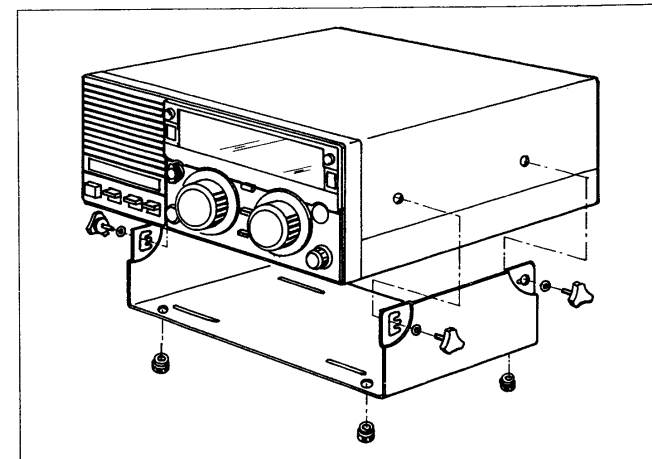
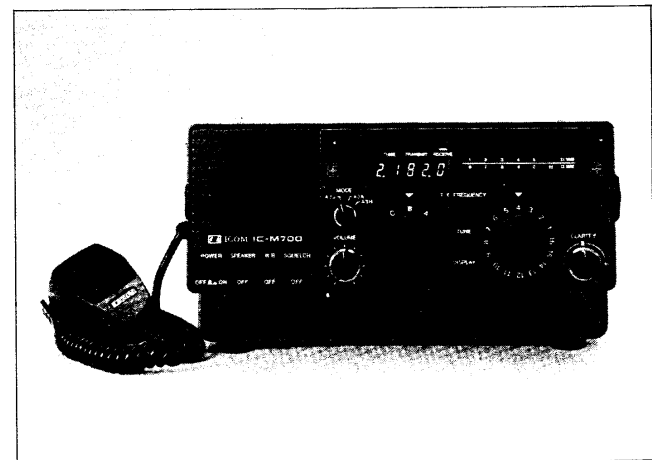
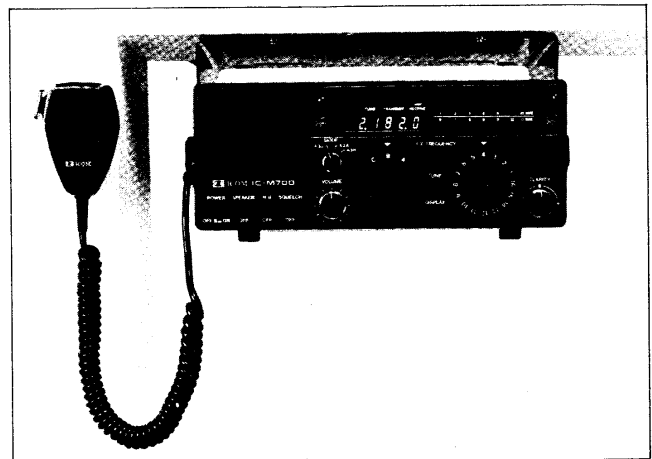

### 3-4 TYPICAL INSTALLATION

The following figure shows a typical installation. Any radio communications system operating with a whip antenna or long wire antenna (insulated back stay) must have an adequate ground connection, otherwise the overall efficiency of the radio installation is degraded especially at lower frequencies.

The 50 ohm output impedance of the transceiver makes it necessary to employ antennas of the trapped or externally matched type. The use of an antenna coupler in conjunc-

tion with a whip antenna or long wire antenna (insulated back stay) allows an efficient installation which will cover all HF marine bands. The transceiver was designed to easily interface with most existing antenna couplers for marine applications.

On wooden or fiberglass boats, the use of a copper ground plate as the ground portion of the keel on a saliboat will often perform adequately. The ground system must be joined to the antenna coupler with a heavy copper strap.

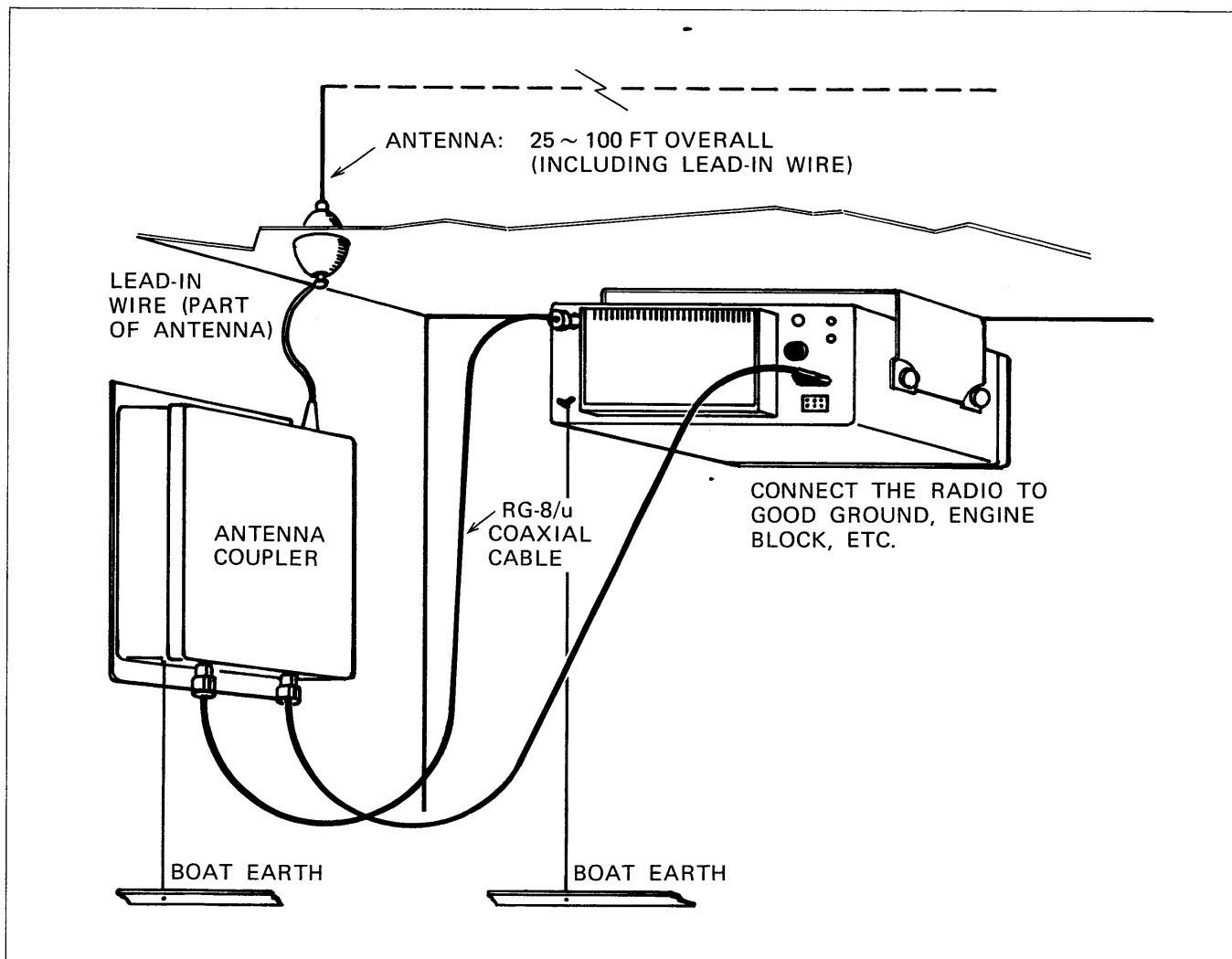

### 3-5 PRIMARY POWER

If at all possible, do not exceed the 10 feet length of the power cable supplied, if it is necessary to make a run over 10 feet use #6 cable, and more than 20 feet should not be used. Use a direct run to the power source. Connect the power cable to the DC power source with the RED lead to the positive terminal and the BLACK lead to the negative terminal. When hooking up the cable, solder all connections and insure that all connections are clean, tight and moisture free.

Be sure to leave a service margin in the power cable so that should the transceiver have to be removed from the bracket it can slide out without straining the cable.

### 3-6 EXTERNAL SPEAKER

The IC-M700 contains an internal speaker, and is also designed so that it can drive an external speaker from the external (EXT) speaker jack on the rear panel. Be sure the impedance of the external speaker is 4 - 8 ohms, and connect it with supplied 1/4 inch standard phone plug.

The external speaker is paralleled to the internal speaker and actuated even if the speaker switch on the front panel is turned off. Thus the external speaker jack can also be used as an AF output terminal for a FAX machine or tele-typewriter.

## SECTION 4 OPERATING CONTROLS

### 4-1 FRONT PANEL

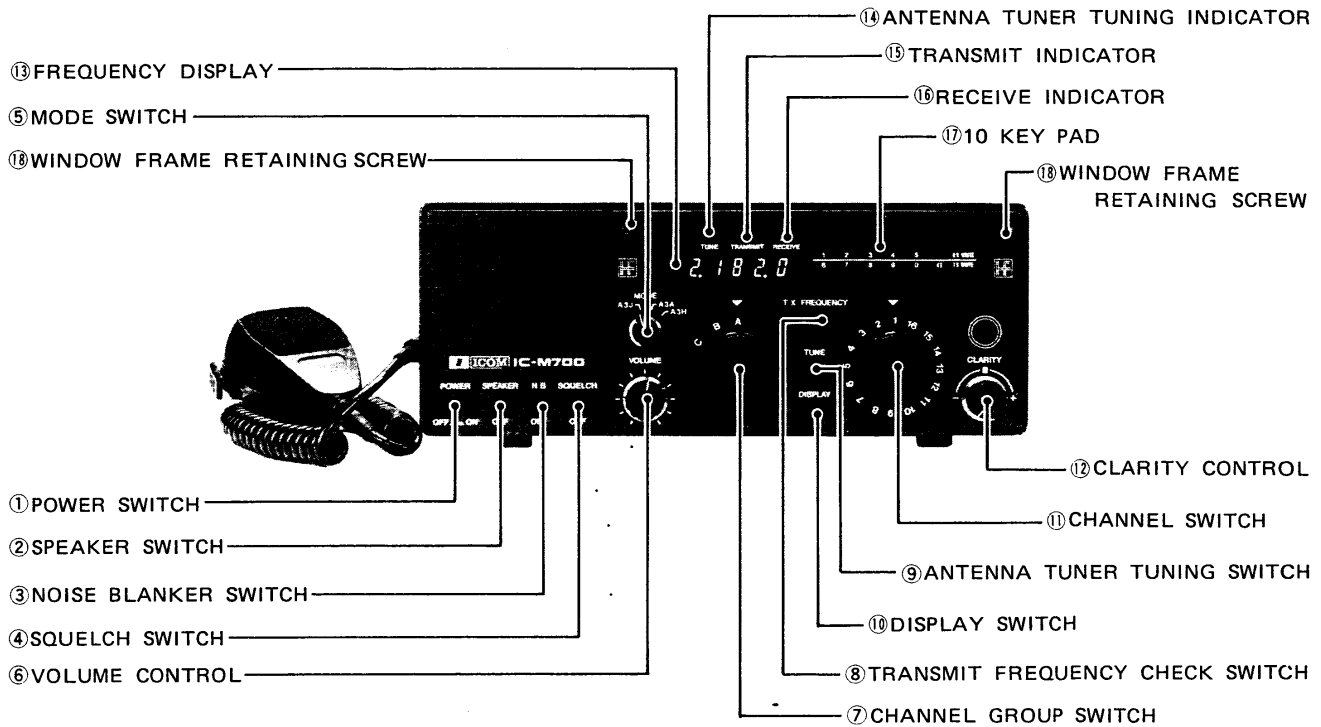

#### 1. POWER SWITCH

The POWER SWITCH is a push-lock type switch which controls the input DC power to the IC-M700. When the switch is pushed in and locked, power is supplied to the set. When the switch is pushed again and released, power is cut to all circuits except the PA unit.

#### 2. SPEAKER SWITCH

Switches the internal speaker ON and OFF. When connecting an external speaker to the external speaker jack, the external speaker will be actuated even if this switch is turned OFF.

#### 3. NOISE BLANKER SWITCH

Switches the noise blanker circuit ON and OFF. When the switch is turned ON (up position), pulse-type noises will be reduced to provide acceptable reception.

#### 4. SQUELCH SWITCH

Switches the squelch function ON and OFF. When the squelch is turned ON, the radio maintains silent until a human voice signal is received.

#### 5. MODE SWITCH

Selects the operation mode, one of A3J (J3E), A3A (R3E) and A3H (H3E). Turning this switch counterclockwise further from A3J position, selects A3J LSB mode.

#### 6. VOLUME CONTROL

Controls the audio output level in the receive mode. Clockwise rotation increases the level.

#### 7. CHANNEL GROUP SWITCH

Selects a channel group, one of A, B and C. Each group has 16 channels, and a channel can be selected by the CHANNEL SWITCH.

#### 8. TRANSMIT FREQUENCY CHECK SWITCH

While holding this switch, the receive frequency changes to the transmit frequency. Thus the transmit frequency may be checked.

#### 9. ANTENNA TUNER TUNING SWITCH

Starts tuning function of the automatic antenna tuner installed. By holding this switch, the radio is turned in the transmit mode and a low power signal is transmitted (this level can be adjusted by an internal control) to tune the antenna tuner. At this time, the ANTENNA TUNER TUNING INDICATOR is ON. When the tuning has been finished, the TUNING INDICATOR goes off and the radio returns to the receive mode.

#### 10. DISPLAY SWITCH

Turns all the display illuminations ON and OFF.

#### 11. CHANNEL SWITCH

Selects a channel, of 16 channels which has been selected by the CHANNEL GROUP SWITCH.

#### 12. CLARITY CONTROL

Shifts the receive frequency 150Hz (maximum) to either side of the displayed receive frequency. This allows clear reception for an off frequency signal. Rotating this control clockwise (+ side) raises the receive frequency and counterclockwise (- side) lowers the receive frequency.

### 13. FREQUENCY DISPLAY

Shows the operating frequency (receiving frequency or transmitting frequency) of the selected channel. The frequency indicated is the carrier frequency of each mode.

### 14. ANTENNA TUNER TUNING INDICATOR

Illuminates when the ANTENNA TUNER TUNING SWITCH is depressed and the antenna tuner is tuning automatically.

### 15. TRANSMIT INDICATOR

Illuminates when the radio is in the transmit mode.

### 16. RECEIVE INDICATOR

Illuminates when the squelch is opened in the receive mode.

### 17. 10 KEY PAD

By pushing these keys, receive frequency and transmit frequency of each channel can be memorized.

### 18. WINDOW FRAME RETAINING SCREWS

By removing these screws, the window frame of the frequency display can be removed and this allows to push the keys of the 10 key pad.

## 4 - 2 REAR PANEL CONNECTIONS

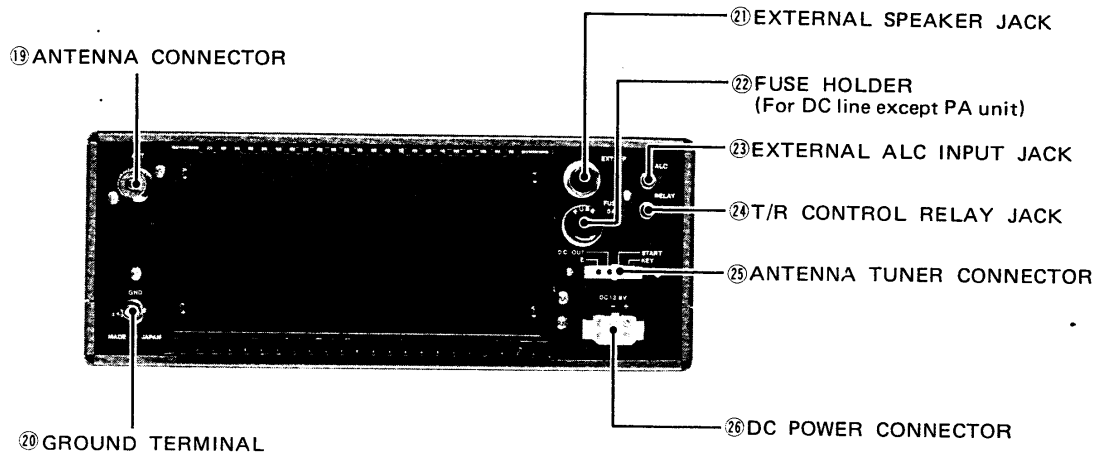

### 19. ANTENNA CONNECTOR

This is used to connect an antenna to the radio. Its impedance is 50 ohms and connect with a PL-259 connector. When using a whip antenna or single wire antenna, use an antenna coupler (antenna tuner) for matching.

### 20. GROUND TERMINAL

To prevent electrical shock, interferences for other electronic equipment and other problems, be sure to ground the radio to good ground such as the engine block through the GROUND TERMINAL. For best results use as heavy a gauge wire or strap as possible and make the connection as short as possible.

### 21. EXTERNAL SPEAKER JACK

When an external speaker is used, connect it to this jack. Use a speaker with an impedance of 4 - 8 ohms. The external speaker is paralleled to the internal speaker and actuated even if the speaker switch is turned off. This jack can also be used as an AF output terminal for a FAX machine or tele-typewriter.

### 22. FUSE HOLDER

This holds a fuse for the DC circuits except the PA unit. If the fuse is blown, replace it with a new 5 Amp fuse. Open the fuse holder with a Philips head screwdriver.

### 23. EXTERNAL ALC INPUT JACK

This jack can be used for input terminal of external ALC (Auto Level Control) signal from a linear amplifier. The ALC voltage should be in 0V ~ -4V.

### 24. T/R CONTROL RELAY JACK

Controls Transmit/Receive for an external linear amplifier or other equipment. This relay can be used to switch 24V 1A DC. Don't exceed this limit.

### 25. ANTENNA TUNER CONNECTOR

This connector is for an automatic antenna tuner (antenna coupler), and puts out a start signal, inputs tuning signal and supplies 13.6V DC for the antenna tuner.

### 26. DC POWER CONNECTOR

For connection of 13.6V DC power source.



## SECTION 5 OPERATING INSTRUCTIONS

### 5-1 HOW TO TUNE

The following instructions are for tuning in any mode. Please read carefully and understand fully before turning ON your unit.

#### 5-1-1 CHANNEL SELECTION

The frequencies shown in the following charts are memorized in the radio already.

To select a channel which is memorized the desired operation frequency, first, select the group, A, B or C, including the desired channel with the CHANNEL GROUP SWITCH. Then, select the channel with the CHANNEL SWITCH.

Set operation mode to the desired one, A3J, A3A or A3H, if it differs.

GROUP		A			
CH	ITU	RX KHz	TX KHz	USE	MODE
1		2182	2182	INTERNATIONAL SAFETY & CALLING	A3J
2		5000	—	TIME & WEATHER	A3H
3		10000	—	TIME & WEATHER	A3H
4		15000	—	TIME & WEATHER	A3H
5		2638	2638	INTERSHIP	A3J
6		2142	2142	INTERSHIP	A3J
7		2670	2670	COAST GUARD	A3J
8		2738	2738	INTERSHIP	A3J
9	424	4428.7	4134.3	MID RANGE/COAST GUARD	A3J
10	601	6506.4	6200	MID RANGE/COAST GUARD	A3J
11	816	8765.4	8241.5	MID RANGE/COAST GUARD	A3J
12	1205	13113.2	12342.4	MID RANGE/COAST GUARD	A3J
13	1625	17307.3	16534.4	MID RANGE/COAST GUARD	A3J
14		2450	2003	KLH/SAN FRAN.	A3J
15		2466	2382	KOU/SAN PEDRO CA	A3J
16		2450	2366	WOU/BOSTON	A3J

GROUP		B				GROUP		C			
CH	ITU	RX KHz	TX KHz	USE	MODE	CH	ITU	RX KHz	TX KHz	USE	MODE
1	401	4357.4	4063.0	KMI TELEPHONE	A3J	1	1609	17257.7	16484.8	WOM TELEPHONE	A3J
2	804	8728.2	8204.3	KMI TELEPHONE	A3J	2	2215	22639.4	22043.4	WOM TELEPHONE	A3J
3	809	8743.7	8219.8	KMI TELEPHONE	A3J	3	2216	22642.5	22046.5	WOM TELEPHONE	A3J
4	1201	13100.8	12330.0	KMI TELEPHONE	A3J	4	410	4385.3	4090.9	WOO TELEPHONE	A3J
5	1202	13103.9	12333.1	KMI TELEPHONE	A3J	5	411	4388.4	4094.0	WOO TELEPHONE	A3J
6	1602	17236.0	16463.1	KMI TELEPHONE	A3J	6	808	8740.6	8216.7	WOO TELEPHONE	A3J
7	1603	17239.1	16466.2	KMI TELEPHONE	A3J	7	811	8749.9	8226.0	WOO TELEPHONE	A3J
8	2214	22636.3	22040.3	KMI TELEPHONE	A3J	8	1203	13107.0	12336.2	WOO TELEPHONE	A3J
9	2223	22664.2	22068.2	KMI TELEPHONE	A3J	9	1210	13128.7	12357.9	WOO TELEPHONE	A3J
10	403	4363.6	4069.2	WOM TELEPHONE	A3J	10	1605	17245.3	16472.4	WOO TELEPHONE	A3J
11	412	4391.5	4097.1	WOM TELEPHONE	A3J	11	1620	17291.8	16518.9	WOO TELEPHONE	A3J
12	802	8722.0	8198.1	WOM TELEPHONE	A3J	12	2201	22596.0	22000.0	WOO TELEPHONE	A3J
13	805	8731.3	8207.4	WOM TELEPHONE	A3J	13	2205	22608.4	22012.4	WOO TELEPHONE	A3J
14	1206	13116.3	12345.5	WOM TELEPHONE	A3J	14		2482	2382	WOX/NEW YORK	A3J
15	1208	13122.5	12351.7	WOM TELEPHONE	A3J	15		2450	2366	WGB/NORFOLK	A3J
16	1601	17232.9	16460.0	WOM TELEPHONE	A3J	16		2442	2400	WDR/MIAMI	A3J

When a channel is selected, the memorized frequency is displayed on the FREQUENCY DISPLAY with 5 or 6 digits down to 100Hz digit. Since the 1MHz and 1KHz

decimal points are displayed, the frequency can be easily read. The frequency indicated is the carrier frequency of each mode.

**5 - 1 - 2 MEMORY WRITING (PROGRAMMING THE CHANNELS)**

When you wish to rewrite the frequency memorized in a channel or to write a new frequency into a channel, the following steps are taken.

1. Select the channel you wish to rewrite or to write a frequency with the CHANNEL GROUP SWITCH and CHANNEL SWITCH. The frequency memorized in the channel is displayed on the FREQUENCY DISPLAY (if no frequency has been memorized in the channel, only the MHz and KHz decimals are displayed).
2. Remove the WINDOW FRAME RETAINING SCREWS and WINDOW FRAME.
3. Set the desired frequency by pushing digit keys of the 10 KEY PAD representing the frequency desired, beginning with the 10MHz digit (or 1MHz digit depending on the desired frequency) and ending with the 100Hz digit.
4. If illegal digits or out of band frequency have been entered, the entered digits are canceled and the FREQUENCY DISPLAY will be blanked (only MHz and KHz decimals are displayed).
5. When wrong key has been pushed, push the "CE" key, the entered digits are canceled and the previous memorized frequency will be recalled.
6. When the entered digits are correct, push the "RX WRITE" key for receive frequency, or the "TX WRITE" key for transmit frequency. The entered frequency will be memorized into the selected memory channel.
7. When a transmit frequency has been memorized, the memorized transmit frequency is not shown on the FREQUENCY DISPLAY. To check the transmit frequency, push the TRANSMIT FREQUENCY CHECK SWITCH. While depressing the CHECK SWITCH, the memorized transmit frequency will be shown on the FREQUENCY DISPLAY.
8. Memorize not only the receive frequency, but also the transmit frequency, even if the both frequencies are the same.
9. If you wish to memorize only a receive frequency into a channel, enter "0" as the transmit frequency (push "0" key, then "TX WRITE" key).
10. Memorize frequencies into other channels with the same manner.

**FOR EXAMPLE:**

When memorizing the receive frequency at 12345.6KHz;

Push key	Display	
	12.357.0	(Previous Frequency)
1	00.000.1	
2	00.001.2	
3	00.012.3	
4	00.123.4	
5	0 1.234.5	
6	12.345.6	
<input type="checkbox"/> RX WRITE	12.345.6	(Memorized into the selected channel.)

When memorizing the transmit frequency at 13210.5KHz;

Push key	Display	
	12.357.0	(Previous Frequency)
1	00.000.1	
3	00.001.3	
2	00.013.2	
1	00.132.1	
0	0 1.321.0	
5	13.210.5	
<input type="checkbox"/> TX WRITE	12.345.6	(This shows the receive frequency.)

**NOTE:** 13210.5KHz has been memorized into the selected channel, but the FREQUENCY DISPLAY will show the receive frequency.

To check the memorized transmit frequency, push the TRANSMIT FREQUENCY CHECK SWITCH.

TX FREQUENCY

	13.210.5
--	----------

## 5 - 2 RECEIVING

After connecting the power cable, an antenna, etc., set knobs and switches as follows:

POWER SWITCH	OFF (OUT)
SPEAKER SWITCH	ON (UP)
NOISE BLANKER SWITCH	OFF (DOWN)
SQUELCH SWITCH	OFF (DOWN)
VOLUME CONTROL	Fully Counterclockwise
MODE SWITCH	Desired Mode
CHANNEL GROUP SWITCH	Desired Group including channel desired
CHANNEL SWITCH	Desired Channel memorized frequency desired
DISPLAY SWITCH	ON (OUT)
CLARITY CONTROL	Center (12 o'clock) position

Now push the POWER SWITCH in. The FREQUENCY DISPLAY will show a receiving frequency and the RECEIVE INDICATOR will be illuminated.

The IC-M700 provides USB (upper sideband) signals in all modes. If you wish to operate on LSB (A3J), turn the MODE SWITCH further counterclockwise from the A3J position.

Slowly turn the VOLUME CONTROL clockwise to a comfortable level.

If squelch function is required to cut out noise when no signal is received, turn the SQUELCH SWITCH on (UP position), and the noise from the speaker stops and the RECEIVE INDICATOR goes off. The radio will now remain silent until an incoming signal (modulated with human voices) is received which opens the squelch and lights the RECEIVE INDICATOR. If the squelch is unstable due to the reception of weak signals or mobile stations, turn off the SQUELCH SWITCH.

When a receiving signal's frequency is slightly off the receiving frequency, adjust the CLARITY CONTROL so that the signal can be heard clearly.

When pulse type noise such as ignition noise is audible, set the NOISE BLANKER SWITCH to the ON (UP) position. The noise will be reduced to provide comfortable reception.

If you wish to cut off the internal speaker when using an external speaker or receiving a FAX or tele-typewriter signal, set the SPEAKER SWITCH to the OFF (DOWN) position.

## 5 - 3 TRANSMITTING

Before transmitting, listen in the receive mode to make sure your transmissin will not interfere with other communications. If the transmit frequency differs with the receive frequency, push the TRANSMIT FREQUENCY CHECK SWITCH, and the radio receives on the transmit frequency while the switch is depressed.

By depressing the PTT (push-to-talk) switch on the microphone, the radio is turned to the transmit mode and the TRANSMIT INDICATOR is illuminated. By speaking into the microphone, transmit signals will be transmitted.

To return to the receive mode, just release the microphone PTT switch.

## 5 - 4 ANTENNA TUNER (ANTENNA COUPLER)

The IC-M700 provides the antenna tuner connector which outputs and/or inputs control signals to control an automatic antenna tuner. The control signal levels can be selected by internal switches, thus most existing antenna tuners can be used.

When S1 (TUNE switch) on the MIC-C unit is set in the "1" position (indicated on the PC board), the "START" terminal of the ANTENNA TUNER CONNECTER is usually grounded (0V), and by pushing the ANTENNA TUNER TUNING SWITCH, the START terminal supplies 8V DC through a 1K ohm resistor.

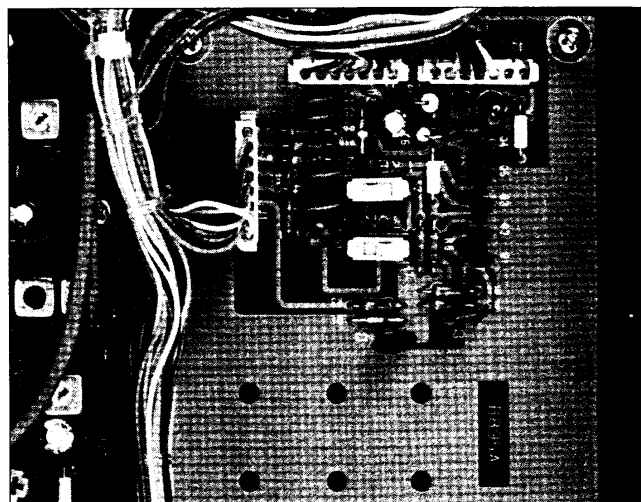

When S1 is set in the "2" position, the "START" terminal usually supplies about 8V DC through a 22K ohm resistor, and by pushing the TUNING SWITCH, the START terminal is grounded (0V) and sinks a current put out from the ANTENNA TUNER.

When S2 (KEY switch) on the MIC-C unit is set in the "1" position (indicated on the PC board), the "KEY" terminal of the ANTENNA TUNER CONNECTER accepts a DC voltage (2V ~ 15V) which is put out from the ANTENNA TUNER, and the radio keeps the tuning function until the antenna tuner has finished the tuning and stops to put out the DC voltage.

When S2 is set in the "2" position, the "KEY" terminal usually supplies about 8V DC through a 22K ohm resistor, and by starting the TUNING function of the ANTENNA TUNER, the KEY terminal is grounded (0V) by the ANTENNA TUNER, and the radio keeps the tuning function until the antenna tuner has finished the tuning and stops to ground the KEY terminal.

When no antenna tuner is connected, the "TUNE" switch does not function.

## 5 - 5 ALARM FUNCTION (OPTION)

The ALARM UNIT will be supplied as an option. When the optional unit is installed, the international alarm signal can be automatically transmitted on 2182KHz by pushing the ALARM SWITCH (included with the ALARM UNIT and installed on the front panel).

### TO TEST THE ALARM FUNCTION

When the radio is set in the receive mode, by just pushing the ALARM SWITCH, the operation frequency is set on 2182.0KHz and the mode is A3H (H3E), even if a different frequency and mode have been set previously, and international alarm signal tones can be heard from the speaker and the ALARM INDICATOR (located next to the ANTENNA TUNER TUNING INDICATOR on the front panel) is lit. The tones will be made for a period of 50 seconds.

To stop the tones, push the ALARM switch again.

To clear the alarm function and to return to the previous operation frequency and mode, push the TRANSMIT FREQUENCY CHECK switch.

### TO TRANSMIT THE ALARM SIGNALS

**CAUTION:** Never transmit the alarm signals except when your ship is in distress.

Push the ALARM SWITCH while depressing the PTT (Push-To-Talk) switch on the microphone, and the operation frequency is set on 2182.0KHz and the mode is A3H (H3E), even if a different frequency and mode have been set previously, and international alarm signals are transmitted. At the same time, the signal tones can be heard from the speaker and the ALARM INDICATOR on the front panel is lit. The radio will be kept in the transmit mode, even if the PTT switch is released, during a period of 50 seconds.

When an antenna tuner is connected, first, the radio is set in the ANTENNA TUNING mode. After the tuner has been tuned on 2182KHz, the radio is turned in the transmit mode automatically and transmits the alarm signals.

After the period of 50 seconds, the radio returns to the receive mode, but the operation frequency and mode will be maintained 2182KHz and A3H (H3E) respectively.

To transmit distress messages, depress the PTT switch and talk into the microphone with normal and clear voices in the usual way.

To clear the alarm function and to return to the previous operation frequency and mode, push the TRANSMIT FREQUENCY CHECK switch.

## SECTION 6 CIRCUIT DESCRIPTION

### 6 - 1 RECEIVER CIRCUITS

#### 6 - 1 - 1 RF CIRCUITS

The received signal is passed from J606 through the 1.6MHz high-pass filter consisting of L666 through L668 and C736 through C741. After the strong broadcast signals are removed, the signal passes the filter which is designed for the desired frequency. This filter is switched by D606 through D619 from among 6 band-pass filters and 1 low-pass filter.

These 7 filters are designed for the following bands:

1.6MHz ~ 3.0MHz	B1
3 MHz ~ 5 MHz	B2
5 MHz ~ 7 MHz	B3
7 MHz ~ 10 MHz	B4
10 MHz ~ 14 MHz	B5
14 MHz ~ 18 MHz	B6
18 MHz ~ 24 MHz	B7

Then the image interference is removed and the 1st and 2nd local oscillator frequencies leaking to the ANT terminal are suppressed by the low-pass filter consisting of L620, L621, C638 through C641, and C743. The signal is then fed to the 1st mixer.

The 1st mixer, featuring low noise and high dynamic range, consists of JFETs Q607 and Q608, and converts the receiving signal into the 1st IF frequency of 70.4515MHz. The 1st local oscillator frequency (70.4515MHz higher than the receiving frequency) from the PLL unit passes the high-pass filter, is amplified by Q609, has its harmonics removed by the low-pass filter, and is applied to the gates of Q607 and Q608.

The signal, converted to 70.4515MHz, passes monolithic crystal filter F11-B, is amplified by Q606, passes a receive/transmit switching diode D604 and a monolithic crystal filter F11-A, and is fed to the 2nd mixer.

The total passband of both F11-A and F11-B is 70.4515MHz  $\pm$ 7.5KHz ( $-3$ dB). The AGC voltage is applied to the 2nd gate of Q606.

The 2nd mixer is a diode DBM (double balanced mixer), IC604 and is injected with the 2nd local oscillator frequency of 61.44MHz from the PLL unit. The 70.4515MHz IF frequency is converted to the 2nd IF frequency (9.0115 MHz) and is fed to the MAIN unit.

#### 6 - 1 - 2 9.0115MHz IF CIRCUIT

The signal, converted to 9.0115MHz by the 2nd mixer in the RF unit, is amplified by Q307 after the mixer's spurious components are removed by the double tuned circuit of L305 and L306.

F1301 (FL-30) and F1302 (FL-33) are crystal filters and their passbands are 2.3KHz/ $-6$ dB and 6KHz/ $-6$ dB, respectively. Q311 switches between these two filters so that F1301 is selected when the mode switch is set to J3E (A3J) or R3E (A3A) and F1302 is selected when the mode is H3E (A3H).

The 2nd IF signal, amplified by approx. 50dB by Q312 and Q313, is fed to the SSB detector IC302, the AM detector D327, and the AGC detector D323.

#### 6 - 1 - 3 DETECTION CIRCUIT

The J3E (A3J) and R3E (A3A) signals are mixed with the 9.013MHz carrier signal at IC302, converted to AF signals, and fed to the emitter follower Q316.

The H3E (A3H) signals are converted to an AF signal at the diode detector D327 and amplified at the buffer amplifier Q317 to match the output level in the SSB mode.

These outputs are fed to the volume control (on the front panel) and the audio controlled squelch circuit.

#### 6 - 1 - 4 NOISE BLANKER CIRCUIT

A portion of the 2nd IF signal from L305 is fed to the noise amplifier, Q301. This signal is amplified by approx. 80dB at Q301, Q302 and Q303, and then rectified by D301 and D302. Q304 is the AGC amplifier for the noise amplifiers and adjusts the gain of the noise amplifiers approx. 50dB. Q305 and Q306 switch on and off the balanced noise gate consisting of D304, D305, D306, and D307.

#### 6 - 1 - 5 AGC CIRCUIT

The voltage rectified by D323 is amplified by Q314 and controls the AGC voltage. The AGC time constant is set to the fast attack/slow release by R372, R373, C376, and C377. The AGC voltage is applied to the 2nd gate of the RF unit Q606, MAIN unit Q307, Q312, and Q313, and is capable of a gain control of 80dB or more.

#### 6 - 1 - 6 BFO CIRCUIT

The 9.013MHz carrier signal is generated by mixing a 10.24 MHz signal, the output of the highly stable PLL reference oscillator divided into 1/3, with a 1.227MHz signal. The 1.227MHz signal is obtained by dividing the oscillation frequency of X301 into 1/4 by CMOS IC312 to get an accurate frequency. For A3H reception, the dividing operation of IC312 is stopped to prevent beat reception.

The clarifier operates during receive by varying the bias voltage of D346 connected in series with X301. To remove the spurious signals of the carrier, the double balanced mixer IC304 is used to mix 10.24MHz and 1.227MHz, and a filter circuit is provided at the input of each frequency. A LPF and double tuned circuit is also provided for the 9.013 MHz output to prevent the generation of spurious signals.

### 6 - 1 - 7 AUDIO CONTROL LED SQUELCH CIRCUIT

A portion of the detector output signal enters the squelch circuit. The input signal is amplified by IC305 to the saturation level and a 3 through 5Hz component is detected by the F-V converter of IC306. IC307 is a full-wave rectifier circuit and rectifies the 3 through 5Hz signal into a DC voltage. IC308 is a switch circuit with hysteresis and becomes L (low) level during audio detection. The output of IC308 is connected to the base of Q329. The collector of Q329 switches the analog switch device IC309 and turns ON/OFF the AF signal. At the same time Q329 lights up the receive LED to indicate the squelch is opened.

### 6 - 1 - 8 AF POWER AMPLIFIER

IC310 is an audio power amplifier from which an output of 5W or more can be obtained. This IC has a low impedance output and has sufficient drive even if a 4 ohm speaker is externally connected in parallel with the built-in 4 ohm speaker.

## 6 - 2 TRANSMITTER CIRCUIT

### 6 - 2 - 1 BALANCED MODULATOR

Audio signals from the microphone are fed to the base of Q315 through the mic gain control R391 and amplified by Q315.

The amplified signals are fed to the double balanced modulator IC301 with the carrier signal the same as for the receiver detector.

### 6 - 2 - 2 9.0115MHz IF CIRCUIT

The DSB signal generated in the balanced modulator IC301 is fed into FI301 (in the reverse direction of the receive mode) and results in the SSB signal. During transmit, FI301 is selected regardless of the operating mode and an SSB signal is obtained. The carrier signal necessary for modes other than J3E (A3J) is combined in the linear amplifiers of Q308 and Q309, following FI301.

The transmitting IF signal is amplified to the rated output of -10dBm and then fed to the RF unit.

### 6 - 2 - 3 RF CIRCUITS

The 9MHz transmitting output from the MAIN unit is mixed with the 61.44MHz local oscillator signal at L611 through 2 and IC604, and converted to the 70.4515MHz IF signal. The spurious components are removed at the crystal filter FI1-A. The signal passes the transmit/receive switching diode D605 and attenuator R645 through 7, then enters the transmitting mixer.

The attenuator acts as a matching network between FI1-A and the mixer and improves the mixer's frequency characteristics.

The transmitting mixer of Q610 and Q611 is fed the local

oscillator signal which goes into the 2nd gate. To improve the frequency characteristics, the output has a resistive load of approximately 500 ohms so that the frequency characteristics are not affected at the output, and the signal is sent through the 25MHz low-pass filter of L629, L630 and C664 through C668, then fed to Q612.

The FET amplifier Q612 has an input impedance of 470 ohms to match the low-pass filter. The drain also has a resistive load. The 2nd gate of Q612 is applied with a control voltage for protection against overcurrents and high SWR, and to control output power.

The output of Q612 is amplified by Q613. To improve the frequency characteristics at Q613, the impedance between Q612 and Q613 is low impedance so input capacitance can be ignored. Further, to compensate the frequency characteristics at the output, C673 is added to the emitter.

The output of Q613, after passing the 1.6MHz high-pass filter, passes through the attenuator of R670 through R672 and is output to the PA unit. The attenuator acts as a buffer to the PA unit. This output is approximately +6dBm when the output is 150W.

To get stable operation, the transmitting circuits are supplied with T8V regulated power supply from the MAIN unit. The local oscillator frequency amplifier circuit also is supplied with an 8V regulated power supply from IC601.

### 6 - 2 - 4 PA PROTECTION CIRCUIT

The voltage of the 2nd gate of Q612 is lowered and the gain is reduced for lower power to protect the final transistors from a temperature rise caused by increased collector loss of the final transistors and overcurrent due to high SWR. This is accomplished by the circuit of IC603, Q605, and Q614.

IC603B is a differential amplifier and amplifies the potential difference generated at R871 (located in the PA unit) due to the current flowing through the PA. Q614 buffers the reflected wave voltage from the SWR detector circuit in the FILTER unit. If either or both voltages exceed the voltage determined by R614 and R681, the inverted amplifier IC603A begins amplification. Normally, the output voltage of IC603B is determined by R614 and R681 through R684. The voltage is lowered due to overcurrent or high SWR and the transmitting power is also lowered.

When the temperature rises, the voltage from J602 pin 4 (POL) turns Q605 on. The output voltage from IC603B is divided by R620 and R621 to lower the voltage and the power is lowered.

Further, when the antenna tuner is connected, the key signal turns Q603 off and Q604 on. The tuning power is set by the voltage divided by R620 and R619.

### 6 - 2 - 5 PA UNIT

This unit consists of 3 boards (PA, ANT SW, and connector) and the rear panel chassis to which they are attached.

The PA board is a linear amplifier with an output of 150W and amplifies the transmitting signal from the RF unit. The ANT SW board performs antenna switching for transmit/receive and has a protection circuit to prevent damage to the receiving unit caused by a strong input during receive when the output of an adjacent transmitter is induced by the antenna. The connector board and rear panel chassis holds the various boards and the wiring for the connectors mounted on the rear panel chassis.

### 6 - 2 - 6 PA CIRCUIT

The power amplifier is a 3-stage wide band linear amplifier and consists of a class A single amplifier for the input stage and class AB push-pull amplifiers for the driver and final stages. This unit produces an output of 150W PEP with an input of approximately 6dBm PEP. Further, each stage uses negative feedback and RC frequency compensation for a total gain variation of  $\pm 1.5$ dB or less (at an output of 55W).

### 6 - 2 - 7 BIAS CIRCUIT

Although the input stage has a fixed bias due to the class A operation, the driver and final stages have adjustable biases due to their class AB operation.

The bias of the driver stage is adjusted by varying the current flowing through D801 with R827. Further, D801 and Q803 are thermally coupled to minimize the variations of the idling current due to temperature changes.

The final stage is provided with emitter follower Q806 since the current flow is greater than in the driver stage. The bias of the final stage is adjusted by varying with R823 the current flowing through D802 and D804. D804 compensates for the voltage drop between the base and emitter of Q806. D802 and Q804 are thermally coupled with Q806 for stability.

### 6 - 2 - 8 THERMAL PROTECTION CIRCUIT

To prevent the final transistors (Q804, Q805) from excessive temperature rises and damage due to continuous transmitting, thermal switches S801 and S802 are thermally coupled to Q804 and Q805, respectively. When the temperature rises, the fan motor provided for the heat sink is turned on for forced air cooling. The fan motor has 4 speeds, transmit high speed, receive high speed, transmit low speed, and receive low speed.

S802 is a 50°C thermal switch and turns on the fan for low speed when Q805 reaches approximately 50°C. At this time, resistors R832 and R834 are connected in series within the motor. S801 is a 90°C thermal switch and turns on when Q804 reaches approximately 90°C. Then R831 is added in parallel to R832 and the motor voltage is

raised. Simultaneously, the POL voltage is supplied to the RF unit to lower the transmitting output by approximately half. Further, during transmit, Q807 shorts R834 to raise the motor voltage higher than during receive, thus increasing the fan speed.

### 6 - 2 - 9 ANTENNA SWITCHING CIRCUIT

Separate relays are used for antenna switching for transmit and receive. The receiving unit is connected to the antenna connector by RL851 and the transmitting unit by RL852. The antenna connector is provided with a surge absorber to prevent damage to the transmitting and receiving units due to high voltages such as induced lightning.

Further, if there is an input at the antenna connector of 1W or more during receive, its voltage is detected and the control voltage of RL852 is switched off by Q854 and Q853. The antenna is then disconnected from the RF unit to protect the receiving circuits.

A low-pass filter with a cutoff frequency of approximately 30MHz consisting of L851, L852, C852, and C854 is provided between the receive switching relay and the receiving input of the RF unit to reduce the incidental radiation from the antenna during receive.

### 6 - 2 - 10 FILTER UNIT

This unit is located between the PA unit and the antenna connector and suppresses the harmonics found in the transmitting output from the PA unit to -65dB or below. Chebyshev low-pass filters are used and 7 filters having different cutoff frequencies are switched depending on the transmitting frequency.

Filter switching is performed by driving the relay with the signal from the LOGIC unit.

At the output is an SWR detection circuit which uses a toroidal core. The detected traveling wave voltage is sent to the MAIN unit to control the ALC and the reflected wave voltage is sent to the RF unit as a control voltage for the protection circuit used to prevent an overload on the PA stage caused by a mismatched antenna.

### 6 - 2 - 11 ALC CIRCUIT

A peak ALC circuit is provided so that the transmit peak level does not exceed the rated output. The traveling-wave voltage detected from the FILTER unit is amplified at operational amplifier IC303 and compared with the reference voltage set by R463 to generate the ALC voltage. This ALC voltage is applied to the 1st gate of Q309 to control the output level of the SSB signal. The ALC voltage is also inverted and amplified by the same IC303 to light up the transmit LED.

Since the circuit for IC303 requires a negative power supply, the oscillator output from IC311 is rectified to produce a -4V.

### 6 - 2 - 13 POWER SUPPLY CIRCUIT

The power supply circuit consists of 11 transistors. Q318 eliminates the chattering of the PTT switch.

Transistors Q319, Q320, Q321, Q323, and Q325 switches REGs T8V and R8V on/off and controls the switching timing. Q319 also controls the linear standby relay. Q322 and Q324 clamps the line to 8V with REGs R8V and T8V, respectively. The 8V of REG Q328 is the reference for all voltages and is made especially stable. A constant current bias is applied to D334 and is obtained after being buffered by Q327. To prevent transmissions on frequencies other than the marine band, a control signal from the LOGIC unit is applied to Q318 and a circuit is provided so that the equipment does not transmit even if the PTT switch is pressed.

### 6 - 3 PLL CIRCUITS

This unit generates 2 oscillating outputs (first and second local oscillator signals) required by the RF unit and another oscillating output (third local oscillator signal) used to produce the BFO frequency within the MAIN unit. Among these, the first local oscillator is a frequency variable output in the 72 ~ 95MHz band and is generated by the PLL circuit having 2 locked loops. The second and third local oscillator outputs are fixed and are produced by multiplying or dividing the reference frequency signals.

The oscillating outputs produced within this unit are all determined by a single reference frequency. Adjusting this frequency corrects all the oscillating outputs.

#### 6 - 3 - 1 REFERENCE OSCILLATOR CIRCUIT

The third overtone oscillator circuit of Q10 and X1 oscillates at 30.72MHz. Since this oscillation frequency determines the frequency within the PLL unit, high stability is required. A thermostatic oven is used for X1 and a stability of  $\pm 0.5\text{ppm}$  at  $-30^{\circ}\text{C} \sim +60^{\circ}\text{C}$  is obtained.

#### 6 - 3 - 2 SECOND LOCAL OSCILLATOR OUTPUT

The output of the reference oscillator circuit is doubled at Q14, has its spurious components removed by the band pass filter of L3 ~ L5, and fed to the RF unit. The output is +3dBm/50 ohms at 61.44MHz.

#### 6 - 3 - 3 THIRD LOCAL OSCILLATOR OUTPUT

The output of the reference oscillator circuit is divided by 3 at IC5 to obtain 10.24MHz. It is fed to the MEIN unit through emitter follower Q203.

#### 6 - 3 - 4 FIRST LOCAL OSCILLATOR OUTPUT

The PLL circuit composed of 2 locked loops, a main loop and sub-loop are used. The sub-loop is used for the heterodyne signal within the main loop and the VCO output from the main loop is used for the first local oscillator output. The sub-loop causes VCO Q201 to oscillate at approximately 115 ~ 120MHz. This signal passes buffer amplifier Q202 and is locked by PLL ICs IC201 and IC202. The phase comparator frequency of this loop is 5KHz and varies

the dividing ratio of the programmable divider within IC201. A frequency variation of 5MHz in 50KHz steps is obtained. The locked VCO output passes through IC204 and IC203, is divided into 1/500 to a frequency of 230 ~ 240KHz. This is mixed by IC4 with the frequency of the reference oscillator circuit and is applied to IC3 within the main loop as a signal having a 10KHz variation in 100Hz steps within 30.95 ~ 30.96MHz.

The main loop switches 4 VCOs to oscillate at a frequency within 72.053MHz ~ 94.4529MHz, required by the first local oscillator. The lock is accomplished by the loop consisting of IC1, IC2, IC3, etc. The phase comparator frequency is 10KHz and varies the dividing ratio of the programmable divider within IC1 to vary the frequency in 10KHz steps. Further, mixer IC3 is provided within the loop. The signal obtained from the sub-loop having a frequency variable in 100Hz steps is used as a heterodyne signal. This covers the frequency variation in 100Hz steps required by the first local oscillator.

The comparator frequency for both the main and sub loops is produced by dividing the frequency of the reference oscillator circuit.

#### 6 - 3 - 5 MUTE CIRCUIT

When the lock of the main or sub loop becomes "unlocked" or when the frequency is varied, the outputs of the first and second local oscillator are blocked to prevent transmitting or receiving on a frequency other than the desired one. The unlock signal output from IC1 and IC201 is given a suitable time constant by Q8 and Q9 and applied to Q24 and Q13 to stop the operation of the amplifiers in the first and second local oscillators, respectively, so that there are no outputs.

### 6 - 4 LOGIC CIRCUITS

All control of the receive and transmit frequencies of this equipment is performed by IC1005.

When the power is turned on, the signal from IC1008 (B) resets IC1005. The receiving and transmitting signal is fetched from the S input terminal and the frequency data stored in the RAM from the port F. (port H is for the control signal for the RAM) Next, IC1005 outputs, from port G, frequency data, PLL's N data (PLL control data), and switching data for the band pass filter and low-pass filter.

As a result of the data from port G and control signals D7 ~ D9, IC1006 outputs band switching data to P60 ~ P73 (Table 1), PLL control signals to P50 ~ P52, and mute signals for outside the marine bands to P41 ~ P42.

IC1007 buffers the outputs for the data from port G of IC1005 and the control signal from P52 of IC1006. IC1009 is the buffer for the low-pass filter switching relay. IC1008 (A) generates the mute signal output for frequencies outside 1600KHz to 23.99MHz.



**TABLE 1**

Port P	Band	B.P.F.	L.P.F.	VCO	Transmit Enable Band
P60	1.6000 ~ 2.9999MHz	B1	L1	V1	2.0000 ~ 2.9999MHz
P61	3.0000 ~ 4.9999MHz	B2	L2	V1	4.0000 ~ 4.9999MHz
P62	5.0000 ~ 6.9999MHz	B3	L3	V1	6.0000 ~ 6.9999MHz
P63	7.0000 ~ 9.9999MHz	B4	L4	V2	8.0000 ~ 8.9999MHz
P70	10.0000 ~ 11.9999MHz	B5	L5	V2	—————
P71	12.0000 ~ 13.9999MHz	B5	L5	V3	12.0000 ~ 13.9999MHz
P72	14.0000 ~ 17.9999MHz	B6	L6	V3	16.0000 ~ 17.9999MHz
P73	18.0000 ~ 23.9999MHz	B7	L7	V4	22.0000 ~ 22.9999MHz

The RAM can memorize 48 channels each for receive and transmit frequencies and can store them for 5 years by means of a lithium battery.

**6 - 5 CIRCUITS ON THE FRONT PANEL**

IC1203 is a latched driver used to drive the 7-segment LEDs (DS1201-DS1206) for frequency display with data from the RAM unit.

Because the LEDs are dynamically lit, the BCD-coded signal from IC1005 in the LOGIC unit is converted to 7-segment data and passes through buffer IC1201 to light up an LED digit.

The output of IC1204 is used as a key scan signal when writing frequency data.

The output from IC1202, Q1202, and Q1203 is used as a control signal to light the MHz and KHz decimal points for zero blanking of the 10MHz LED.

IC1205, Q1205, and Q1206 comprise the key input gate for the frequency data and is used to output key scan data from IC1204 to port F of IC1005 in the LOGIC. (IC1205 uses a 3-state gate since port F is used while switching the input and output.)

S1228 is used to disable the key input and a key cannot be input in the open state.

Q1219 and Q1213 checks for receive and transmit based on the signal from the MAIN unit and outputs to IC1005 in the LOGIC unit.

Q1208 to Q1212 buffer the signal for mode switch S1224 and outputs to the MAIN unit.

**6 - 6 CIRCUITS ON THE MIC UNIT**

This board receives the signal from the MIC connector. This board is selectable according to the type of MIC and antenna tuner.

J1303 is a connector for the MIC. The use of each pin is as follows.

1. AF AF output from the main board.
2. PTT PTT pin. Transmits when shorted with pin 3.
3. PTTE Ground pin for the PTT.
4. MIC MIC ground pin.
5. MIC MIC pin. When shipped from the factory, a DC voltage is applied but becomes input through a capacitor when W1301 is cut.
6. NC
7. AF Connected to the built-in speaker. When the speaker switch is turned on while shorting pins 1 and 7, the built-in speaker is used.

**USE OF THE SWITCHES**

The 2 switches are for the antenna tuner which uses the output voltages from KEY (pin 1) and START (pin 2) of the tuner connector on the rear panel.

**S1 TUNE SWITCH**

1. Right side (as seen from the front): Normally, approximately 8V appears at the START pin. It is grounded when the tune switch on the front panel is depressed. (0V, sink)
2. Left side: Normally 0V. Approximately 8V appears at the START pin (internal resistance approximately 1K ohm) when the switch on the front panel is depressed.

**S2 KEY PIN SWITCH**

1. Right side: Tuning operation. The tuner sinks current. (approximately 0.4mA flows out) Normally open. (8V, 22K ohm)
2. Left side: Tuning operation. Voltage appears from the tuner side. (2 - 15V) Current: 50 - 400µA.

**6 - 7 OTHER CIRCUIT**

The rear panel chassis is mounted with the power input connector and other accessory connectors and serves to handle their wiring as well as those to each unit. Directly after the power connector is a reverse connection protection circuit of D872 and D873 which prevents damage to the equipment when the (+) and (-) terminals of the power cord have been inadvertently connected in reverse.

# SECTION 7 BLOCK DIAGRAM

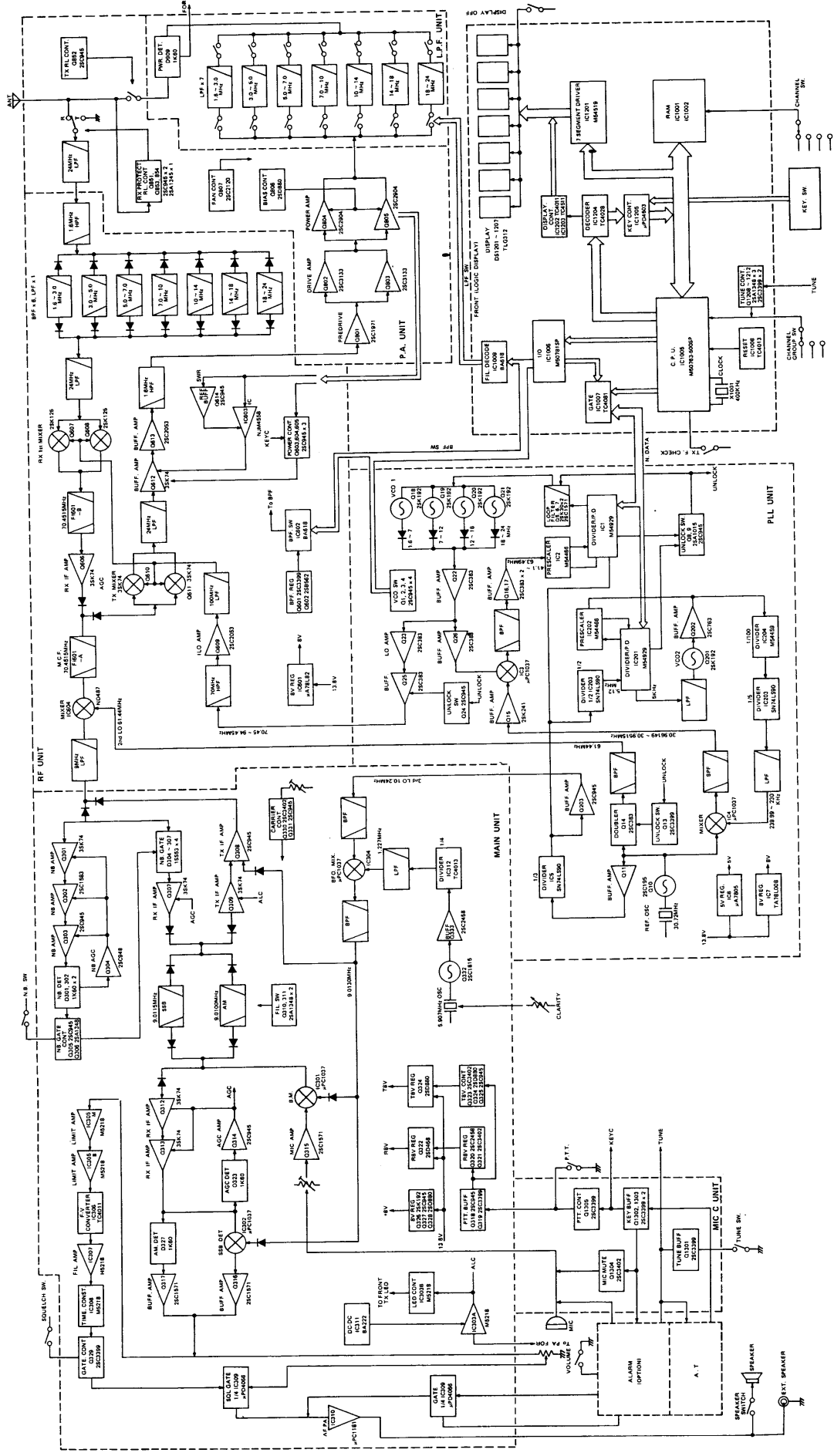



**ICOM INCORPORATED**  
1-6-19, KAMI KURATSUKURI, HIRANO-KU,  
OSAKA JAPAN