

ADMINISTRATION and MARKETING
Pembroke House, Campsbourne Road
Hornsey, London N8
Telephone 01-340 3291
Telex 267727 BATGRP G

FACTORY
231-235 Liverpool Road
London N1 1LY
Telephone 01-607 8271 (5 lines)

SYNCON RECORDING CONSOLE
OWNERS MANUAL Issue two 1979

PRODUCT LIABILITY:

SOME OF THE PROCEEDURES DESCRIBED IN THE MANUAL INVOLVE
THE USE OF ELECTRICAL TOOLS. ANY DAMAGE CAUSED BY MISUSE
OF SUCH TOOLS WILL NOT BE RECTIFIED UNDER GUARANTEE.
IF YOU ARE IN ANY DOUBT AS TO THE CORRECT PROCEEDURE PLEASE
CONTACT A QUALIFIED AUDIO TECHNICIAN.

Issued with unit
Serial Number.....
Date...SEPT '79

CAREY

SYNCON MANUAL CONTENTS

SECTION ONE : RECEIPT OF GOODS

SECTION TWO : PREPARATION

SECTION THREE : INSTALLATION

- 3: 1 Assembly of stand
- 3: 2 Assembly of Jackbay/producer's desk option
- 3: 3 Power supplies
- 3: 4 Audio earthing
- 3: 5 Console termination systems
- 3: 6 Connection of microphones
- 3: 7 Connection of tape recorders
- 3: 8 Connection of monitor power amplifiers
- 3: 9 Connection of auxiliary outputs
- 3: 10 Connection of echo return inputs
- 3: 11 Connection of jackbay systems
- 3: 12 Options:
 - 1. Phantom power off
 - 2. Mixdown mode defeat
 - 3. Routing assignment
 - 4. Reduced monitor level
 - 5. Expansion of small format consoles
 - 6. Metering mixdown mode

SECTION FOUR: COMMISSIONING

- 4: 1 System checkout
- 4: 2 Reissue of printed circuit boards

SECTION FIVE: SCHEMATICS AND DRAWINGS

	REF NUMBER
Stand assembly	Fig 1
Stand/Jackfield fixing details	Fig 2
Jackfield fitting	Fig 3
Jackfield front joiner	Fig 4
Stand position and console dimensions	Fig 5
Power supply connections	SM01
Discrete op-amp S02 circuit detail	SM02
Chassis wiring schematic	SM07
Meterhood schematic	SM08
Bus jumper detail	SM09
General arrangement diagram I/O module	SM04
General arrangement diagram stereo module	SM05
General arrangement diagram monitor module	SM06
Circuit diagram I/O module type SC7	SC02
Circuit diagram stereo module SS6	SC03
Circuit diagram monitor module ST6	SC04

SECTION ONE: RECIEPT OF GOODS

The items listed below are packed in one carton and comprise the standard SYNCON package. If any items have suffered damage in transit immediately notify Allen & Heath Brenell Ltd, and the shipping agent. Delay may jeopardise insurance claim validity.

<u>ITEM</u>	<u>QUANTITY</u>
Power supply NTS305	1
Power supply NS305	1
Power supply NS500	1
8 meter power cable	1
Service kit	1 Spare amplifiers & fuses Terminal strips Service extender connectors Zero Volt PSU jumper
Manual	1
Stand tube	2
Stand feet	2 pairs
Stand brackets	2 L.H. 2 R.H. (1 each per stand)
Syncon Console	1

SECTION TWO: PREPARATION

STANDS: If the hollow stands are to be used as audio harness trunking refer to figure 5 for positioning and cable dress information. Console may be attached to stands at the final location or in advance. A 10mm A.F. (O.B.A) spanner is required.

POWER SUPPLIES: The standard power connecting cable allows location of supplies up to 24 feet total cable length from the console. Storage space should be suitably ventilated. All connections to supplies are from the front panels. The supplies measure 2ft x 1ft x 1ft; 2ft x 9ins x 1ft; 9ins x 9ins x 4ins; and the total weight is 60. lbs.

CONSOLE: The console weight is 300 lbs (150 kg) approximately. If access to the control room included staircases it is recommended that the channel modules are unloaded at the delivery point. The stereo output and monitor modules do not contribute significant weight and may be left in place. The console weight is then reduced to 80 lbs. When handling the console grip the main frame directly, do not lift by the wood side trims. The meterhood is hinged and the console should not be tilted more than 45° down at the meter hood side.

REMOVAL OF CHANNEL MODULES.

To lighten the console for carrying on staircases remove channel modules following the procedure below. Left hand end channel should be left in place if the stereo output and monitor modules are not removed to balance support of the meter hood.

- 1). With console out of its packaging and on a flat surface raise the hinged meter hood. Release arm rest catch beneath each end of arm rest and open it.
- 2). Using 2PT Pozidrive screwdriver release the fixing at each end of the channel modules. It is unnecessary to remove these screws completely, they are self retaining.
- 3). Lift the fader end of the module from the frame slightly to free the edge connector circuits, then lift the module clear from the frame enough to gain access to the phono plug at the meter hood end. Pull the phono plug free. Withdraw module completely and store on a flat surface. Avoid impact with any part of the module/printed circuit board assembly.

When console is transported to its destination replace the modules, locate the fixing screws in receptacles before applying light pressure to mate the edge connectors.

Drawings SMO4, SMO5, SMO6 show the arrangement of audio terminations which are fanning strips soldered to the audio lines. The ^{se}screw down onto receptacles on the rear of the channel modules. ^

CAUTION: Do not plug modules into the console chassis while Test-tone, or any other signal source is connected and power is on. This is likely to blow the module supply fuses. Modules can be plugged into the chassis when power is on and all signal sources muted without risk.

SECTION THREE: INSTALLATION

3: 1 FITTING THE STANDS TO SYNCON

The two stands should be pre-assembled with the two folding "feet" at the bottom and the rigid supports at the top. The "V" shaped cutout being at the top of the "leg". Ref Fig 1. The stand is assembled with ten M6 X 15mm long, hexagon headed screws, (an O.B.A. or 10mm A.F. spanner is suitable).

Select whether the SYNCON is to be operated flat, or at 5° tilt using the lower row of holes when fitting the top supports.

Remove the M6 screws and nuts from the rear cable trough of the SYNCON. (Beneath hinging meter hood). The SYNCON should now be supported in a perpendicular position with its arm cushioned on a soft pad. It is important not to lift the SYNCON by its wooden side trims as they are not intended for mechanical support. Also, be sure sufficient manpower is available as the SYNCON weighs 100 kgs, (220 lbs) approximately.

Offer up the assembled stands to the underside of the SYNCON. Note that the single hole in the top of the supports goes towards the front of the mixer. Fig 2. shows the location of the stand supports and its fixing points. It is suggested that the M6 screws in positions 'a' (four per stand) should be fitted first into the threaded inserts in the chassis.

Unless a Jackbay is to be attached, fit the remaining M6 screws with nuts into the rear cable trough, also the self tapping No. 10 screws into the chassis as shown in Fig 2. The self tapping screws require a 2PT Pozi screwdriver.

The SYNCON can now be lifted into its intended operating position. Check that all screws and so on are tight.

The legs of the SYNCON stand are hollow to allow interconnection cables to be ducted from underfloor trunking to the Console rear cable trough. Details of stand positions for cable ducting are given in Fig 5.

3: 2 FITTING OF AH/B SYNCON JACKBAY/PRODUCERS DESK

The SYNCON Jackbay is designed to fit at either end of the Console.

- a) Having decided which end to fit the Jackbay, it is necessary to remove the long wooden side trim on that side. To do this, remove the adjacent modules from the SYNCON (consult service instructions concerning their removal - Section 3: 6). Undo the three wingnuts on the inside of the chassis side plate. Remove the wooden side trim and its spacers. The spacers will not be required on the Jackbay. The modules may now be replaced into the chassis and screwed down. Note that the wood trim at the end of the meter hood is not removed.
- b) Fit the SYNCON wooden side trim flush to the metal side of the Jackbay using the three wingnuts. It may be necessary to relocate

3: 2 b) continued

the black rear panel so that it butts against the inside face of the wooden trim. This is held in position by four self tapping screws. The "overhanging" end of the rear panel on the opposite side is to cover up the gap between the SYNCON and the Jackbay. See Fig 3.

Due to the interference of the rack panel fixing screws on the horizontal Jackbay mounting area to the top edge of the wooden side trim, it may be necessary to undo the panel fixing screws a couple of turns and then to re-tighten them once the wood side trim has been fitted. This will prevent damage to the top edge of the wood trim.

- c) Remove the fasteners marked on Fig 2 with a 'b' from the underside of the SYNCON.

Slide the Steel Centre Joiner and the right angled Rear Joiner into the square and rectangular holes respectively in the SYNCON chassis side.

- i) The Rear Joiner should be located firmly against the inside wall of the cable trough. The clearance holes in the Joiner allow for the protrusion of the Pop rivet heads from the chassis.

The Joiner locates approximately half way into the console, the large holes for the M6 screws and nuts will only coincide between Joiner and chassis in one position. Fix with five M6 X 15mm long hexagon headed screws.

- ii) Slide the steel Centre Joiner into the chassis (square hole) so that the end without the threaded inserts protrudes the same distance from the side of the Console as the Rear Joiner.

Fit the five M6 screws and the two No. 10 self tapping screws through the chassis and stand supports, as shown on Fig 2, into the Centre Joiner.

- d) Slide the Jackbay assembly onto the two protruding joiners, so that the ends of the joiners locate in the cutouts of the Jackbay side member, see Fig 3.

From the underside of the Jackbay fit two No. 10 X 10mm ($\frac{3}{8}$ ") long self tapping screws through the clearance holes in the flanges of the Jackbay side members into the Centre Joiner. (2PT Pozi screw drivers required).

As in Fig 3, locate spacer washers between Rear Joiner and Jackbay side member flanges (to lower effective height by 2mm).

Fix in position using two No. 10 self tapping screws.

- e) In order to offer complete support to the Jackbay and producers desk, the front joiner should now be attached. To do this, fold the arm rests down on both SYNCON and Jackbay by pushing back the release levers underneath.

The front Joiner supports as per Fig 4. It is anchored in position using the eight M5 screws and nuts. (These may be 2BA in some cases).

3: 2 continued

f) SYNCON Jackbay Rack.

The Jackbay has facilities for mounting standard G.P.O. 19 inch Rack size units. Depending upon the section of the Jackbay chosen, the different unit depths can be accommodated. The horizontal mounting area is shallow, restricted by the strengthening flanges in the Jackbay chassis side members. The area is ideally suited to 96 way Bantam or T.T. type Jack panels as supplied by Switchcraft, A.D.C., etc.

Details of 96 way 5 point (balanced) jacks are as follows:-

SWITCHCRAFT:-

Available in UK from Canadian Instruments & Electronics Ltd. Harris-Bass House, Station Road Ilkeston, Derby.

ADC

Available in the UK from CAE Ltd. 77, Akenman Street, Tring, Herts.

or

Future Film Developments
36-38 Lexington Street,
London, W1R 3HR.

SWITCHCRAFT:-

No. 1634B Double Row Panel Assembly with 96 "T.T. JAX" (Part No. TT34B JAX) Ready Assembled with Designation strips and wiring bars
As in Switchcraft Catalogue J110A
Switchcraft Modular (TT51-02534B) "Tini-Telephone" Jack Panel Assembly Fitted with two "FFD" Miniature Lacing Bars.

ADC

No. PJ 739 Double Row panel Assembly with 96 "BANTAM JACKS" (Part No. PJ839 with Solder Tails) Ready Assembled Complete with Designation strips and wiring bars

PATCH CORDS:-

24" TT124	24" PJ714
18" TT123	18" PJ713
12" TT122	12" PJ712

g) Cable from the pre-wired jack panels for channel insertion points should run to the front of the Jackbay and lay in the front cable trough beneath the arm rests.

Cable wired from the mixer's rear terminations to appear at the jackbay can be passed through the rectangular hole, common to SYNCON and Jackbay where the rear joiner is attached.

Refer to section 3: 11 for connection of jackbay systems.

3: 3 POWER SUPPLIES

Note: For the purpose of earthing arrangement descriptions the following glossary of terms applies:

- 1) A.C. earth: the non current carrying safety wire included in electricity supply Company terminations. Usually connected to a conductor buried in the ground to provide a low impedance path. European convention for A.C. Power earth in equipment power cables is YELLOW/GREEN colour coded insulation.
- 2) CHASSIS: The metal structure housing the equipment circuits. for reasons of safety this is usually connected via the power cable to A.C. Power earth.
- 3) GROUND, COMMON: The return path for signal current in unbalanced equipment terminations. Also the zero volt side of the equipment internal electronic power supply circuit.
- 4) SCREEN: Metallic foil or Braided conducting sheath around one or more signal wires between equipment.

SYNCON has three power circuits, refer to diagram SM01 for the schematic of power distribution.

SUPPLY FUNCTION	SUPPLY TYPE
AMPLIFIER ELECTRONICS \pm 24 volts	KINGSHILL NTS305
LAMP & RELAY CIRCUITS + 24 volts	KINGSHILL NS305
MICROPHONE PHANTOM POWER +48 volts	KINGSHILL NS500

All three supplies are regulated and stabilised, in addition they include output current limiting and short circuit protection. The NTS305 supply is fitted with output over-voltage protection.

Each supply requires connection to A.C. Power. The maximum A.C. Power consumption is 500VA. unless requested otherwise all supplies are set for 240v AC 50/60Hz operation and will tolerate a 10% deviation in supply voltage. For use on other supply voltage the internal connections to power supply mains transformer primary should be re connected as required. Refer to manufacturers data book.

Connection to the console.

The power supply outputs are connected to the mixer using the six way cable and plug card provided. The console power input socket is located at the rear of the console beneath the hinged meter hood.

- 1) Disconnect supplies from AC power
- 2) Following diagram SM01 and the cable 'A' 'B' identification connect the cable to the supply output terminals. Connect the short black lead between NS500 48 volt supply black (0V) terminal and NTS305 0 volt terminal.
- 3) Raise meterhood to open position. Insert plug in socket. Engage plug retaining clip.

3: 4 AUDIO EARTHING

Due to the number of separate units in any studio complex operating from AC power, and the signal interconnections between them, hum sensitive earth loops are a danger to low level audio signals. A hum loop occurs when two separate pieces of equipment are connected to A.C. earth by more than one path e.g. between unbalanced console and power amplifier; both chassis connected to AC earth (path 1), mixer ground connected to amplifier ground along the signal cable screen (path 2). The loop is sensitive to all types of interference and can cause instability due to inaudible high frequency signals as well as audible hum which degrades the wanted signal. It is good practice to make the console the central AC earth point by connecting the console amplifier supply 0 volts and chassis ground, which are common, to AC earth via a substantial conductor. The terminal beneath the console power input socket is provided for this purpose. Other unbalanced equipment may then be connected with chassis AC earthed in the normal way and the signal cable screen connected only at the console end via the audio ground terminals 'E'.

When balanced, 3 wire outputs or inputs are connected to the console the cable screen and black (cold, -ve phase) conductor should be connected together at the console audio ground terminals and the screen not connected at the other end.

If hum and interference problems persist when equipment connections follow this system, it is possible that the studio complex AC earth is introducing interference from other power users in the same building. This may warrant the installation of an independent studio technical earth which is a substantial conductor buried in the building foundations to provide a low impedance interference free path. This conductor is then terminated at the studio central earth point and original AC power earth circuit disconnected. Because this process involves the safety of mains powered equipment, it should be carried out only by qualified engineers.

3: 5 CONSOLE TERMINATIONS

SYNCON uses two termination systems for audio lines:

- 1) Module interface for microphone, tape recorder and monitor amplifier circuits use two-part 12 way screw down terminal strips to accept soldered connections. These are located beneath the hinged meter hood.
- 2) Module insertion points terminate on $\frac{1}{4}$ inch three pole jack sockets. These accept the AHB pre-wired plug in jack strips and are located inside the hinged arm-rest (All).

3: 5 continued

SYNCON uses the low output impedance, high input impedance system for matching to external equipment. The impedance of output lines is less than thirty ohms and will give excellent interference rejection provided care is taken with audio earthing. Refer to section 3: 4. Maximum output level from SYNCON is +24dBm, and 2dB higher into bridging loads. Ensure that external equipment can accept these signal levels without overload. Output line amplifiers are protected against continuous short circuits to ground. The minimum recommended load impedance is two hundred ohms.

SYNCON input circuits are voltage operated, minimum input impedance is ten kilo - ohms, and will accept all external line level sources without significant loading effects.

When adjusted for unity gain SYNCON input circuits will overload when the incoming signal exceeds +26dBm. External equipment with operating levels higher than SYNCON (0vu = +4dBm) and output level capability higher than +26dBm should be adjusted or suitably padded down to prevent overload distortion.

3: 6 CONNECTION OF MICROPHONES

Each SYNCON Channel module (A) has three terminals on the rear 12 way strip for connection of microphone sources. These are marked H1, LO and E. A positive going pulse at the H1 terminal will generate a same phase pulse at the channel output. Input impedance is optimised for balanced output 200 ohm microphones. + 48 volts is distributed to each H1, LO terminal via 6.8 kilo ohm resistors to drive condenser microphone capsules. The microphone load is a floating transformer primary preceded by a pad bypass switch. The pad provides 20dB attenuation and substitutes a resistive load network at the input terminals. The input E terminal is the ground for the channel and should not be earthed via control room/studio wiring to any other earthed equipment, trunking or panelling.

Normal procedure for connecting three wire cables to three pin XLR type studio sockets should be followed. Connect H1 terminal to microphone cable + Ve phase terminal, LO terminal to -V phase and 'E' terminal to pin 1 only. Microphones and cables with either signal line connected to pin 1 (unbalanced type) should not be connected into this system due to the action of phantom power current when unbalanced.

If certain channels are required without phantom power for unbalanced sources follow the procedure below:-

- 1) Raise hinged meter hood to open position.
Release 12 way screw terminals on barrier connector.
- 2) Remove fixing screws from each end of the module using No. 2 pt. pozidriver blade.
These screws are self retaining.
- 3) Release arm rest catch at each end of the arm rest and hinge out.

3: 6 continued

- 4) Lift module vertically free from location at fader end first. Remove phono plug from meter send socket and rest it outside the module location to prevent accidental short ccts.
- 5) Remove module and place on a smooth surface component side up.
- 6) Identify bare wire link 'B' located between MIC/LINE gain controls and 12 way terminal strip. To disconnect + 48v supply to the MIC input terminals cut link 'B'.
- 7) Replace meter send phono plug in socket. Relocate channel in chassis using only light pressure to drive edge connectors home when module is correctly positioned.
- 8) Refit 12 way terminal and module fixing screws.

Note: When removing and replacing channel modules it is not normally necessary to switch power off. However, if high level signals e.g. slate tone, is live on channel input during plugging the additional current surge may blow the supply line fuses located between the centre pair of edge connectors. In case of problems check fuses first and switch off all signal sources.

3: 7 CONNECTION OF TAPE RECORDERS

The channel output, line input and tape monitoring system in SYNCON are designed for use with all types of multitrack and master recorders currently available. Two connection systems are described.

- 1) Recorders with single outputs per channel selectable either to replay or sync. Connect channel line output to track record input. See section 3: 4 for wiring configuration and earthing details.

Connect track output to channel line input. To provide a signal to channel monitoring section link terminals 'LINE IN' and 'TAPE IN' on 12 way terminal strips.

- 2) Recorders with separate replay and sync outputs. Connect channel line output to track record input. Connect track replay output to channel line input. Connect track sync output to channel tape input.

CONNECTION OF MASTER RECORDERS (B4, C4)

The SYNCON Mixdown/Monitor master faders (B2) provide final level control for the quad monitoring or mastering mix.

3: 7 continued

The quadrophonic image conversion is:

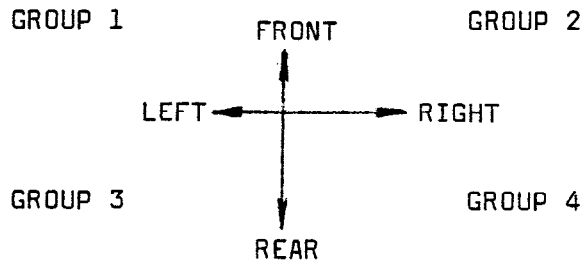

The quad line outputs appear on stereo module 12 way terminals as 'QUAD MAIN OUT'. Master recorder record inputs connect to these terminals. Stereo master recorders should use the front groups. Back groups are available for simultaneous stereo copying. Additional recording outputs in stereo (L = 1 + 3; R = 2 + 4) and mono are permanently available from terminals 'STEREO MIX L, R' and 'MONO'. Master recorder outputs connect to the monitor module (C) 12 way terminals 'TAPE MONITOR 1, 2, 3, 4; L, R; MONO'. These are selected for monitoring by the monitor buttons 'TAPE' (C4).

3: 8 CONNECTION OF MONITORING POWER AMPLIFIERS

Console outputs for loudspeaker monitoring appear at the rear of the monitor module (C) on the 12 way barrier strip terminal groups "Mon 1, 2, 3, 4E", "Studio L, R, E" "Squawk L, R, E". Each output is a line level signal with full output capability and low output impedance. The three groups of monitor outputs provide:

- 1) Main control room monitoring,
in quad "mon 1, 2, 3, 4",
or stereo "mon 1, 2".
- 2) Alternative domestic quality control room monitoring,
in stereo "squawk L, R".
- 3) Studio playback monitoring in stereo, including talk back,
"studio L, R".

Each of the three systems requires a power amplifier with the appropriate number of channels and power capability. When connecting to power amplifier inputs which are unbalanced (input ground = chassis), care must be taken to avoid earth hum loops. Refer to section 3: 4 on audio earthing. Amplifier manufacturers usually quote sensitivity figures for maximum rated output. This sensitivity ranges between 100mV RMS (-18dBm) and 1.4 volts RMS (+4dBm = SYNCON OVU). The output of the SYNCON monitoring section is adjustable using the monitor level control (C3) over a 40dB range, +14dBm to -24dBm. When sensitive amplifiers are used this control will normally be at a setting below half, reducing the available control. If it is required to reduce the monitoring output level for this reason refer to section 3: 12 OPTIONS: (4) REDUCED MONITOR OUTPUT LEVEL.

3: 9 CONNECTION OF AUXILIARY SENDS (B2)

The four master level controls located in pairs on the two SYNCON stereo modules (B) provide a total of six line level output circuits terminating on the 12 way terminal strips at the rear of the modules. Terminals are identified according to the send control markings on the channel modules as Aux send A, B left, B right, C, D left, D right. Connection of individual circuits to effects units and fold back systems is determined by particular studio requirements. For wiring configurations and earthing details refer to section 3: 4.

3: 10 CONNECTION OF ECHO RETURN SYSTEMS (B1, B3)

Access to all mixing points in SYNCON for echo return mixing is provided by the three echo return systems on the SYNCON stereo modules (B). The line level inputs are available on the 12 way terminal strips at the rear of the modules. Basis requirements for wet recording and monitoring of echo plate or reverb signals is met by connecting inputs 'ECHO RET BUSS' and 'QUAD ECHO RET 1 to 4' in parallel to the output of the effect unit. Connection of inputs 'ECHO RET AUX' is determined by allocation of Auxiliary sends A to D as fold back and echo send systems. More flexible echo return facilities are provided by channels 25-28 which are not normally required as multitrack record outputs. Connect effect unit outputs to the line inputs of these channels and use the equalisation, auxiliary sends and routing for more adventurous effects.

3: 11 CONNECTION OF JACKBAY SYSTEMS (A11)

Accessory consoles complementing the SYNCON profile are manufactured by AH/B. These accept the AH/B 19 inch panel 96 way TT/Bantam type assembly pre-wired on on the first 30 pairs to 3 pole $\frac{1}{4}$ inch jacks for use with the channel module jack socket breakpoints located inside the hinged arm rest. The remaining 18 pairs are available for studio custom wiring.

Each channel module has three $\frac{1}{4}$ inch 3 pole jack sockets available for insertion,

- 1) CHANNEL OUTPUT
- 2) CHANNEL PREFADER
- 3) CHANNEL POST MIC/LINE, PRE EQ.

This is the sequence of sockets as seen when the armrest is hinged open.

Internal circuitry around each breakpoint preserves the low output impedance high input impedance format in addition to full drive capability. Breakpoints for the monitor-mixdown master groups, pre master fader, are located on the stereo modules. Tone oscillator output is available from the monitor module socket. All sockets except oscillator are wired:

SLEEVE = GROUND (0v)
RING = RETURN (Oscillator no circuit)
TIP = SEND

3: 11 continued

The wiring and contact configuration of the standard AH/B pre-wired jack strips is shown below with a recommended system for wiring of additional balanced circuits (e.g. Microphone inputs) between external equipment and SYNCON 12 way terminal strips.

AH/B PLUG IN CONFIGURATION

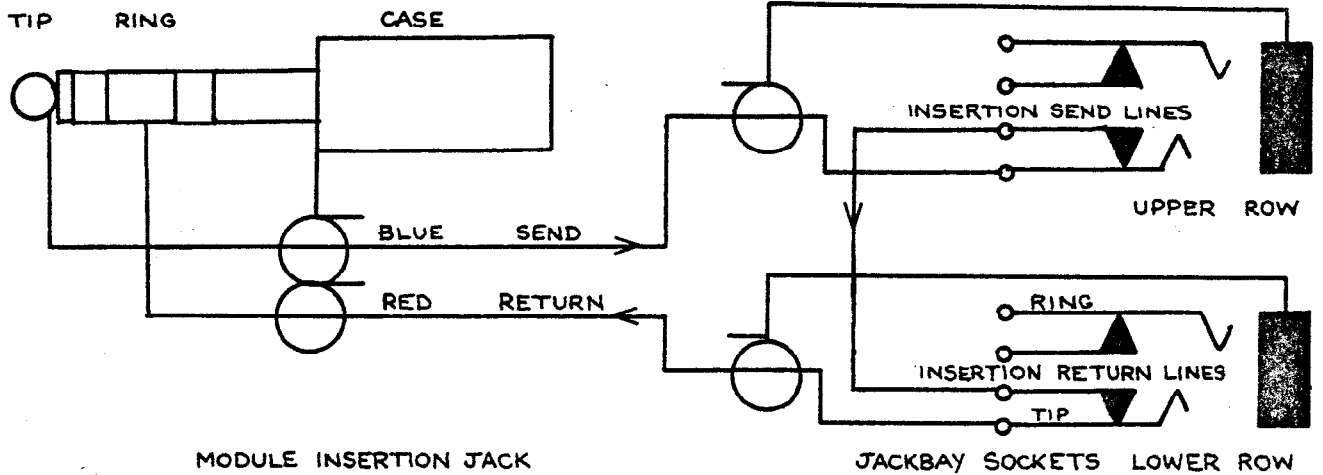

CONNECTION OF BALANCED CIRCUITS

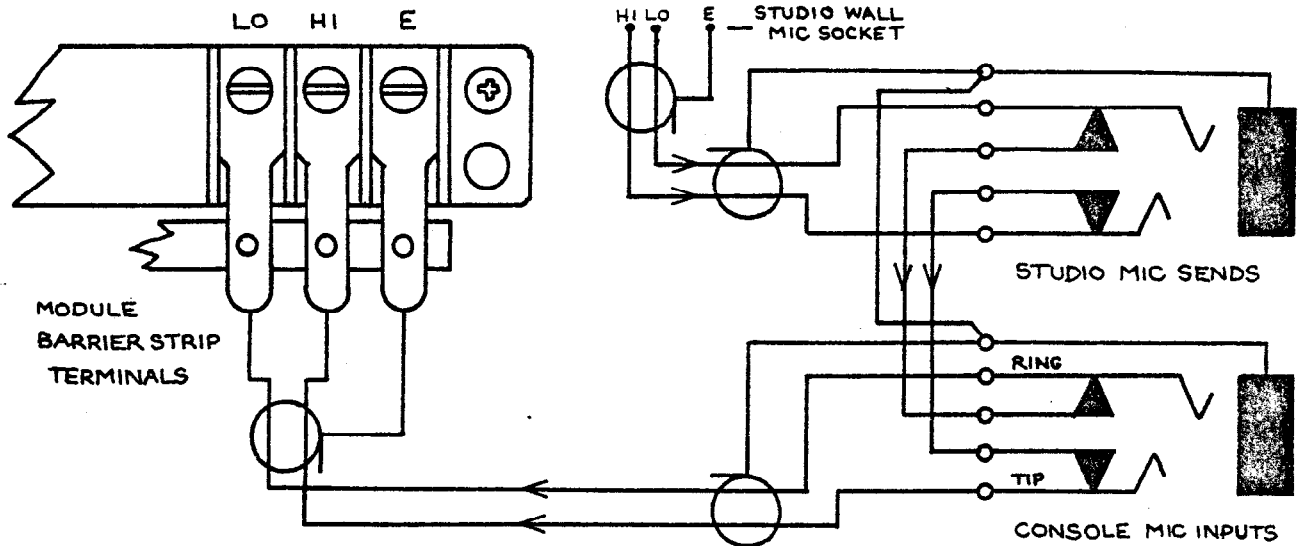

See section 3: 2 for assembly and attachment of AH/B plug in Jackbay console.

3: 12 OPTIONS

1) DISCONNECTION PHANTOM POWER

To remove the 48v supply to all microphone inputs disconnect the positive terminal from the kingshill NS500 supply and reconnect it to the negative terminal (Black).

To remove the + 48v supply to particular channel module refer to section 3: 6 connection of microphones.

2) MIXDOWN MODE DEFEAT

This may be desirable on one or more channel modules to permit overdubbing live vocals or instruments as required during final mixing sessions. The modification restores the normal microphone line selection available at the channel input and defeats track metering and monitoring status on the channel selected.

To defeat mixdown mode on a channel module:

- i) Remove channel module from chassis and transfer to a suitable level work surface. Refer to section 3: 6. connection of microphones for procedures when removing channel modules.
- ii) Locate edge connector pin no. 35. Sequence starts with no. 1 pin at terminal strip end of module. Pin 35 carries the D.C. control to the mixdown relays (C5, 1 to 5) diagram SCol. Using instrument cutters cut pin 35 between the edge connector and the printed circuit board. Trim the break to prevent intermittent reconnection.
- iii) Replace channel module in chassis following procedure of section 3: 6.
Repeat for required number of channels.

ERRATUM

The relay C5 is shown on diagram SCol as C5 1 to C5.5. Note that switch position C5.3 is shown in the Mixdown Position and not the Record Position as intended.

- 3) The available chassis buss bars for use as mixing points to channel outputs total sixteen. These 3 buss bars are accessed through the Module routing button section (A5) and pan pot. Each buss bar is connected to one channel summing amplifier and the channel receives its number from the buss bar i.e. channel one receives the sum of signals on buss one. There is no limitation other than ergonomic sense dictating module sequence across the console. Since the maximum SYNCON module capacity is greater than the number of mixing busses provision has been made to subdivide the sixteen busses into groups. The division is made between channel module locations sixteen and seventeen. All sixteen mixing buss bars are interrupted at this point and are brought through the chassis on the buss bar jumper assembly. Using this assembly a number of mixing buss configurations are possible, three useful options are detailed.

3: 12 3) continued

- i) STANDARD FORMAT: For use with 16 or 24 track recorders. To eliminate microphone re patching as many channel outputs (track record inputs) as possible are made available from the channel routing sections.

BUSS FORMAT

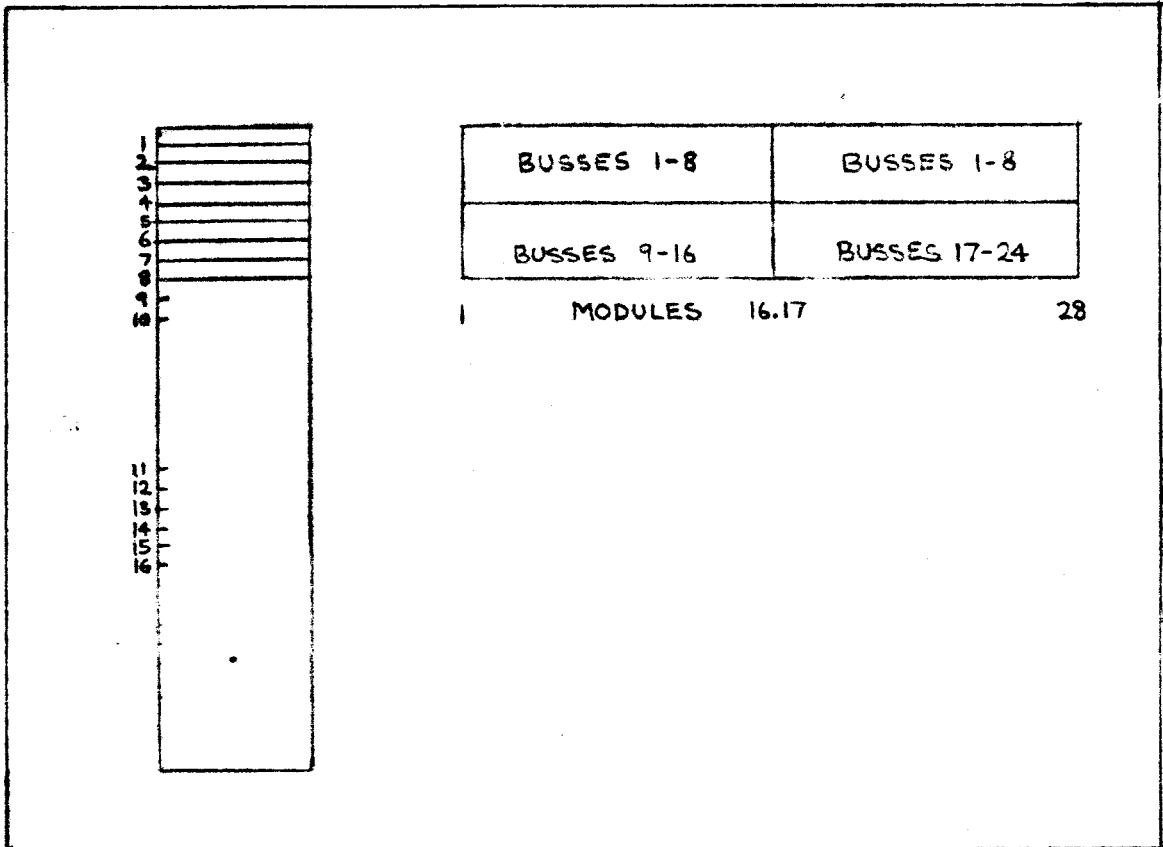

Any channel module can access outputs 1 through 8.
Channel modules 1 through 16 can access outputs 9 through 16.
Channel modules 17 through 28 can access outputs 17 through 24.
Modules 25 through 28 are not used as record outputs unless directly assigned (see A9).

3: 12 3) continued

iii) Options for 16 track recorders.

All sixteen mixing busses run full chassis length.

BUSS FORMAT

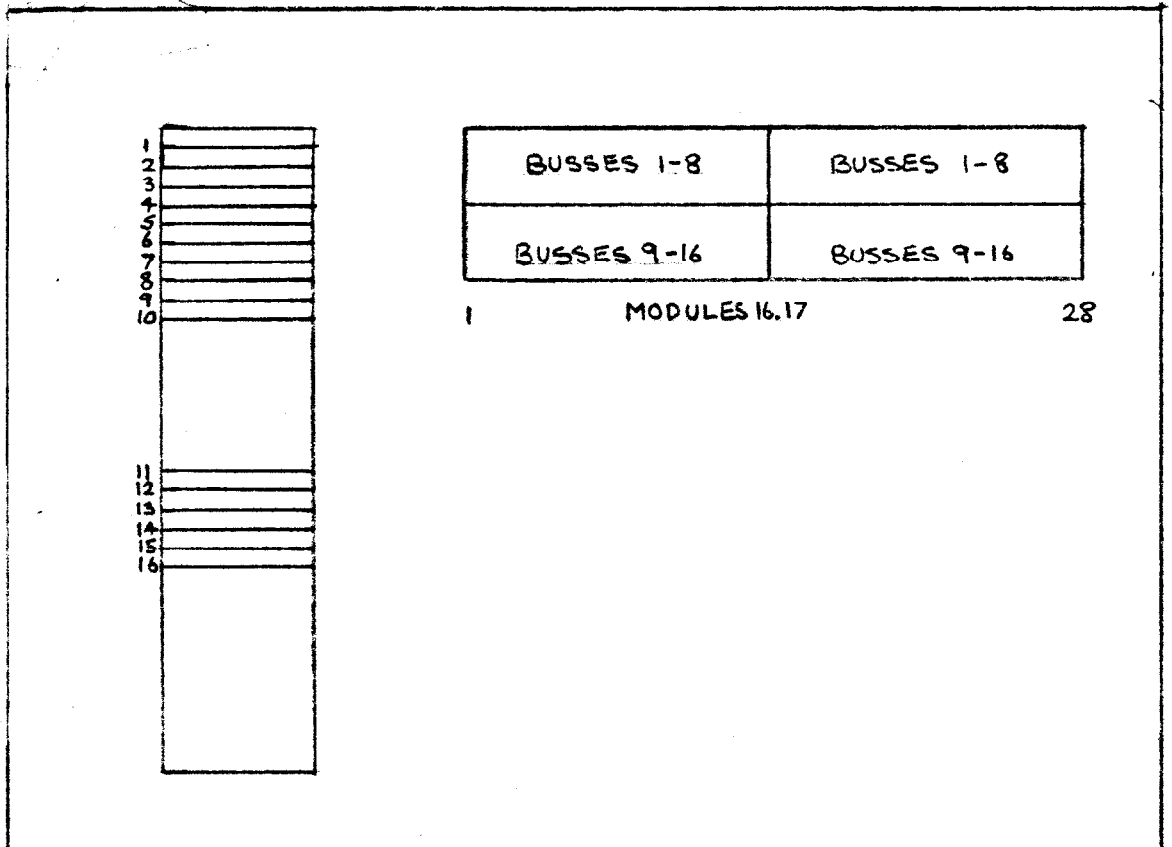

Any channel module 1 through 28 can access outputs 1 through 16.

Modules 17 through 28 are not used as record outputs.

In all cases the buss format is indicated by the number sequence on the channel routing button markings. Alternative sets of buttons for the optional configurations are available to order. When ordering please specify in detail the quantity and type of button required or quote option type from the three detailed.

3: 12 3) continued

- iv) Rearrangement of buss jumper assembly.
The buss jumper assembly is installed in the SYNCON during manufacture to original order specification.
Other configurations can be selected following the procedure below:
- a) Remove channel modules 16 and 17 from chassis following procedure in section 3: 6 connection of microphones.
 - b) Remove buss jumper from chassis sockets.
When viewed in the installed position buss link one is the first pair of pins counting from meter end to arm rest end. Edge connector fingers have polarising keyways down the right hand faces.
 - c) Using 20 swg or similar tinned copper wire rearrange the connection format across the two halves of the buss jumper. Insulate the joining links.

Form the links to preserve the separation of the edge connector fingers throughout the assembly, degradation of channel crosstalk will result if adjacent links are in close proximity. Do not attach any circuits to edge connector pins 17, 18, 19 and 20 these these carry supply voltages.
 - d) Check modified buss jumper assembly for correct circuits and accidental short circuits. Replace the assembly in the chassis sockets followed by modules 16 and 17 (follow procedure in section 3: 6.
- v) Procedure
- a) Remove channel module from chassis. See section 3: 6 for procedure.
 - b) Refer to channel module general arrangement drawing and locate channel summing amplifier first stage
The input circuit is via the black wire between the edge connector and the input capacitor 100 uF, 3v Tantalum type. Assign the channel by resoldering this wire to minimum length and form it to avoid all other components and edge connector pins.
 - c) Replace the module CUT/IDENT button with appropriate new number. The button cap/black extender assembly should be eased from the switch actuator shaft. Only light pressure is needed to relocate the assembly which snaps positively into the correct position.

Replace the channel routing buttons to make the new assignment and module location.

Replace channel module in the chassis. (see section 3: 6).

3: 12 continued

RE-ASSIGNMENT OF CHANNEL MODULE TO ALTERNATIVE BUSS FORMAT

It is important that only one channel summing amplifier is assigned to any one mixing buss. If two or more are connected there will be loss of level and increases in noise and distortion.

If one were changing the console format from split buss routing to continuous buss routing (option 3) it would be necessary to change the buss assignment of channel modules 17 to 24 from busses 17 to 24 (in the case of option 1) to an unterminated state.

If this were not done then, for example, mixing buss 16 would feed channel summing amplifiers on modules 16 and 24.

Any module can be assigned to pick up any of the sixteen busses available at a given point within the chassis. Obviously in a split buss console module 1 cannot pick up buss 24 as this buss does not reach that end of the console.

4) REDUCED MONITOR OUTPUT LEVEL

Some monitoring power amplifiers in current use will be driven beyond maximum output when console mix is to normal 0vu levels and the monitor level control set to normal (number seven position), due to high power amplifier input sensitivity.

The following procedure reduces the monitor output levels at terminals "mon 1, 2, 3, 4" and "squawk L, R" by approximately 20dB to match such power amplifiers.

- i) Remove all four monitor module (C) fixing screws using Pozidrive no. 2 point driver. The screws are self retaining. Withdraw the $\frac{1}{4}$ inch plug from the tone output socket inside the hinged armrest if this has been used, remove both 12 way terminal strips.
- ii) Lift the module vertically until the edge connectors are free. Raise the meter hood end of the module and remove the four meter send phono plugs. Hang the free plugs over the rear frame to avoid accidental short circuits. Withdraw the module completely and remove it to the work bench.
- iii) On the main pcb (telesyncon ST5) six $\frac{1}{4}$ watt 10 kilohm resistors are located beneath the barrier strip terminal block. These will be used to form an attenuator pad on the output circuits.
 - a) Identify the six barrier terminals "mon 1, 2, 3, 4" and "squawk L, R". Trace these through the panel to the short links onto the main pcb. Remove these links. Replace each link with one $\frac{1}{4}$ watt 5% resistor, value 82 kilohms.
 - b) Lift the ends of the six 10 kilohm resistors further from the panel by unsoldering on the reverse side. Reform each resistor end to reach the appropriate barrier terminal end and solder it to the terminal with the 82 kilohm resistor.

3. 12; 5 SYNCON: Addition of modules to small format consoles

This information applies to units ordered and shipped with less than sixteen channel modules.

When less than 16 channel modules are fitted in the main-frame some of the 16 mixing buses will not be terminated in a channel bus mixing amplifier, in these cases the mixing bus assembly is modified during manufacture to prevent abnormally high bus-to-bus crosstalk caused by the higher (+60 to +70 dB) signal level on an unterminated mixing bus. The bus-jumper assembly (see diagram SMO9) has a circuit added which connects the unterminated mixing buses to audio ground. Example: Buses 13 to 16 incl. grounded in a 12 channel console.

When updating a console of this reduced format the mixing bus assembly needs to be returned to its unmodified state. For each new channel module added to the main-frame the corresponding bus grounding circuit should be removed. Follow the procedure below.

Procedure when adding modules.

- 1) Remove grounding link "A" on the bus-jumper assembly. (Refer to diagram). Note that if the new module complement remains under sixteen some buses will remain grounded.
- 2) Assign new modules to the bus system. Each module bus input receives the signal from the bus of the same number. Assignment uses the black conductor on the channel P.C.B. which terminates on the corresponding edge connector terminal. Before inserting additional modules in the frame check that the module edge connector wiring corresponds to the channel number. Refer to diagram schematics SMO4, SCO2.

Note: The function of the channel assignment wiring changes with the console bus system. When the format is 16 buses over the full console width all modules above 16 will have no assignment circuit attached to the edge connector. When the split bus format is applied modules 25 to 28 will have no bus assignment. Refer to manual section 3.12.3.

Should two modules accidentally be assigned to the same bus the result for both modules is a drop in output level, increased distortion and noise. The fault will be indicated by simultaneous meter indication from two channels when only one has been routed to.

3.12:6 METERING : MIXDOWN MODE.

The twenty-four channel meters are under the control of the channel DUB switches and the 24T master monitor selector. These controls provide meter reading of channel output and channel tape input. When console is in the MIXDOWN mode all meters are switched to channel TAPE input. In operation these input are connected to taperecorder SYNC outputs or linked to the channel LINE inputs. As a result it is possible for the meters to show SYNC while mixing takes place on REPRO signal, meter indication will be fractionally ahead of the audio.

The following modification allows the meters to read line input REPRO signal when the console is in MIXDOWN. Other functions are not affected.

- 1) Remove each channel module to be modified from the chassis. Refer to section 3.6.
- 2) Locate PCB link 'A' on the component side of the PCB between large four pole relay RLA and the small single pole relay RLB. This link carries TAPE input signal to RLA.
- 3) Do not disturb the link end soldered both sides. Cut and remove the other piece of link.
- 4) Connect RLA to the channel LINE input signal by adding a piece of screened wire between the vacant link hole and the LINE input terminal at the barrier strip. Terminate the screen at the barrier strip E, screen should be cut back and insulated at the other end.

SECTION FOUR: COMMISSIONING

4: 1 SYSTEM CHECKOUT

- 1) Verify that power supplies are delivering correct output on load. Voltages quoted in section 3:3 are nominal and may vary by plus or minus 0.5 volt. Phantom power distribution should be checked at the studio outlets or jack bay. A fault on individual microphone circuits will not affect others.
- 2) Place meterhood in operating position. Verify that each meter pointer rests over the zero, end of scale, point. Adjust if necessary with the black button beneath each meter to obtain mechanical zero setting.
- 3) Raise meter hood to open position. Remove spring wire shorting shunt from the meter signal terminals behind each meter. Store these for use to prevent shock damage to meters if console is removed at a later time.

TONE TEST (C1)

This test verifies basic operation of the console and the wiring between console and tape recorders. Console should be out of 'MIXDOWN' mode. Release Red button on monitor module. (C5).

- 1) Select tone on, slate, 1KHz 'level' to middle setting. Select monitor mode 'QUAD' (C4). Channel meters 1-8, 17-24 read signal level. Adjust tone pot for OVU. (A9)

Select 'ON', 'SUB' on channel one. Raise channel fader (A10) to normal position. Set panpot central. Route to channels 9-16 (A5)

- 2) Raise any monitor fader (A8) 1-24 to normal position and Quad faders 1 - 4 to normal position. Large quad meters 1 -4 read OVU.
- 3) Select 'SOLO' channel one. Solo indicator illuminates. Large meters 3 and 4 read channel solo level.
- 4) Release 'SOLO' channel, select 'SOLO' monitor (A9). Other indicator illuminates. Large meters 3 and 4 read monitor solo level.
- 5) Release 'SOLO' monitor. Either set tape machine in record or select tape channel monitor mode to return incoming signals back to mixer tape inputs.

Select console '24T' monitor mode on monitor module (C4), channel meters now show incoming signal.

- 6) Record tone on tape. Playback in replay mode. Select desk 'QUAD' monitor mode and 'MIXDOWN' mode. Channel meters show incoming line input signal.

NOTE: If short circuits exist in the wiring between console output and tape recorder the channel meter indication will be removed in all modes.

In the event of a failure, before attempting any work to the printed circuit boards in this console, please telephone the Factory (Factory telephone number 01 607 8271) and request SYNCON TECHNICAL ADVICE.

4.2 REISSUE OF PRINTED CIRCUIT BOARDS AUGUST 1979

INPUT/OUTPUT MODULE.

Original PCB designation SC5
Updated to SC7 August 1979

CHANGES: Components reference added.
Tape input buffer changed to S02 plug-in.
Equaliser circuitry changed to include input buffer in signal path when EQ CUT selected.
Pre EQ insertion point PCB tracking deleted and replaced with screened wire.
Solo switches changed to ground the solo mix-resistors when in the un-operated position.

Modules fitted with SC7 pcbs are compatible with the previous issues and may be fitted in the standard chassis.

STEREO MASTER MODULE

Original PCB designation SS5
Updated to SS6 August 1979

CHANGES: Solo switches changed to ground solo mix-resistors when in the un-operated position.
Minor pcb track modifications to improve reliability and manufacturing efficiency.

Modules fitted with SS6 pcbs are compatible with the previous issues and may be fitted in the standard chassis.

MONITOR MODULE

Original PCB designation ST5
Updated to ST6 August 1979

CHANGES: Add-on relay-control pcb ccts transferred to the main pcb.
Minor pcb track modifications to improve reliability and manufacturing efficiency.

Modules fitted with ST6 pcb are compatible with the previous issues and may be fitted in the standard chassis.

When requesting spare parts or service information please specify the PCB issue number (below the barrier terminals, component side.)

NOTES

A basic stand is assembled using M6x15 hexagon headed screws. (10 off)

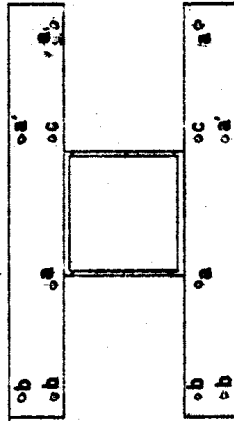

For horizontal operation

For 5 degree tilt, use this row of holes.

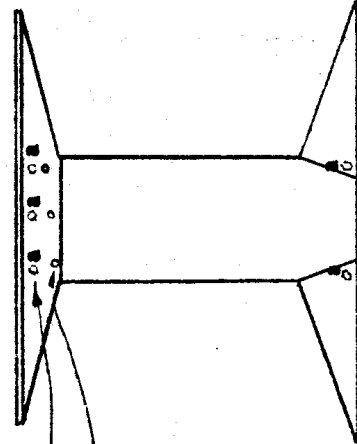

FRONT

To fit stand to Syncon :

Support mixer in perpendicular position, using soft cushion pads as shown.

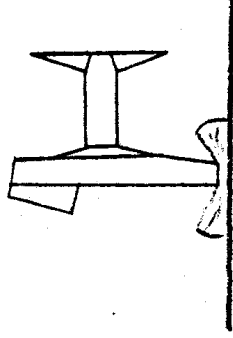

Attach using :-

- a - M6 x 15 hexagon head screw into tapped insert
- b - M6 x 15 hexagon head screws and M6 nuts.
- c - No.10 x $\frac{3}{8}$ " self tapping pan head screw, into chassis.
- a' - Used when Jackfield is fitted.

Allen and Heath Limited.

Pembroke House, Campsbourne Road.
London. N8. 7BR. Tei: 01-340-3291.

STAND ASSEMBLY

SYNCON

FIG. 1

M.A.

7/4/78

SYNCON CHASSIS VIEWED FROM UNDERSIDE

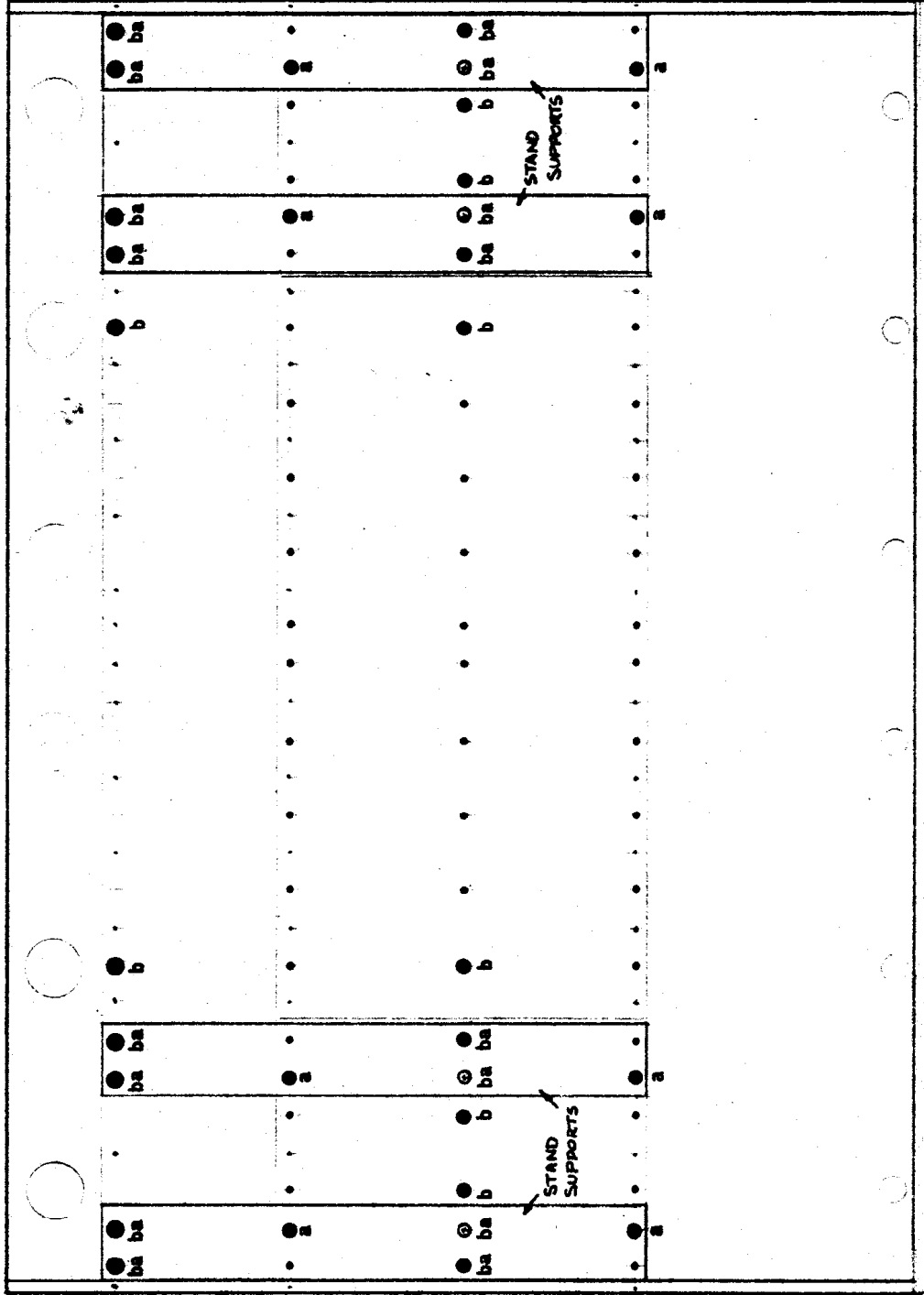

- No. 6ABx ³/₈ " self tap. screws, holding base plates to chassis
- No. 10x ³/₈ " self tap. screws.
- M6x15 hex-head screws into tapped inserts in chassis.
- M6x15 hex-head screws and M6 nuts.
- Used to fit Stands
- Used to fit Jackfield joiners.

Allen and Heath Limited.

Pembroke House, Campsbourne Road.
London. N8, 7BR. Tel: 01-340-3291.

SYNCON STAND & JACKFIELD FIXING DETAILS.

FIG 2

MARTE 4/4/78

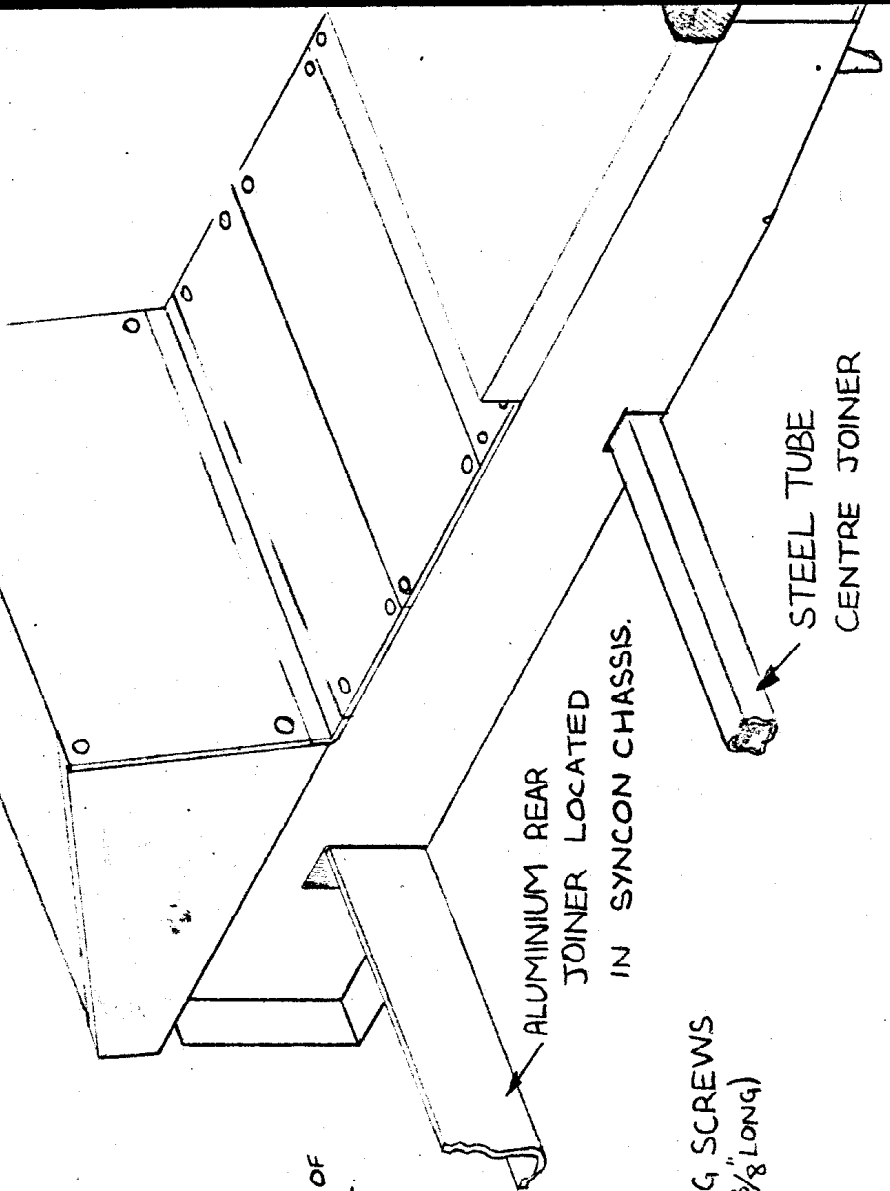

JACKBAY SHOWN RIGHT HANDED

ALUMINIUM REAR JOINER LOCATED IN SYNCON CHASSIS.

STEEL TUBE CENTRE JOINER

NOTE POSITION OF REAR PANEL.

4 SELF TAPPING SCREWS (No. 10AB x 3/8" LONG)

VIEWED FROM UNDERSIDE LEFT HANDED

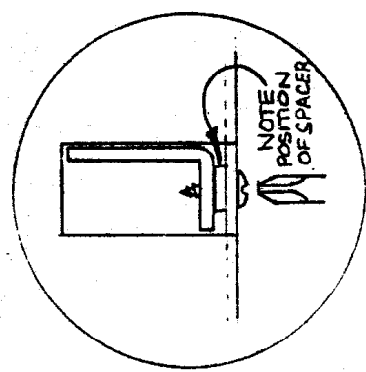

NOTE POSITION OF SPACER

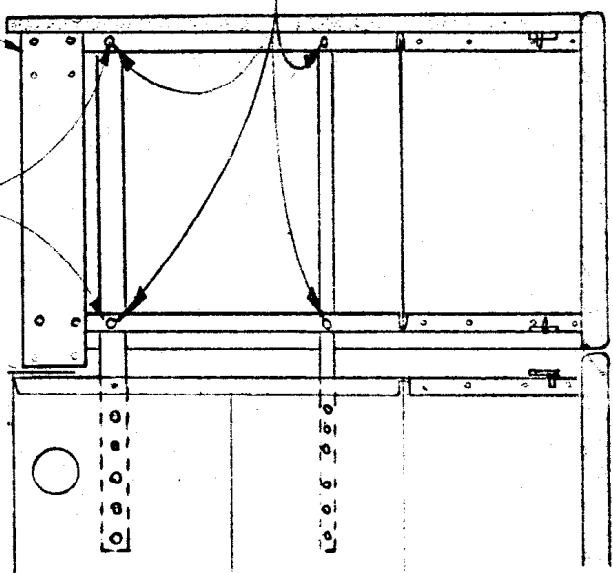

SYNCON JACKBAY FITTING

Allen and Heath Limited.

Pembroke House, Campsbourne Road,
London, N8, 7BR. Tel: 01-340-3291.

FIG 3

MA 3-10-78

ALUMINIUM FRONT JOINER

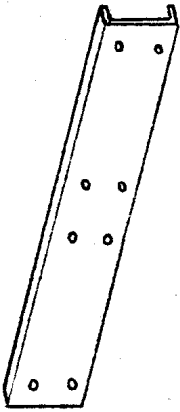

* = FIXING HOLES FOR FRONT JOINER.

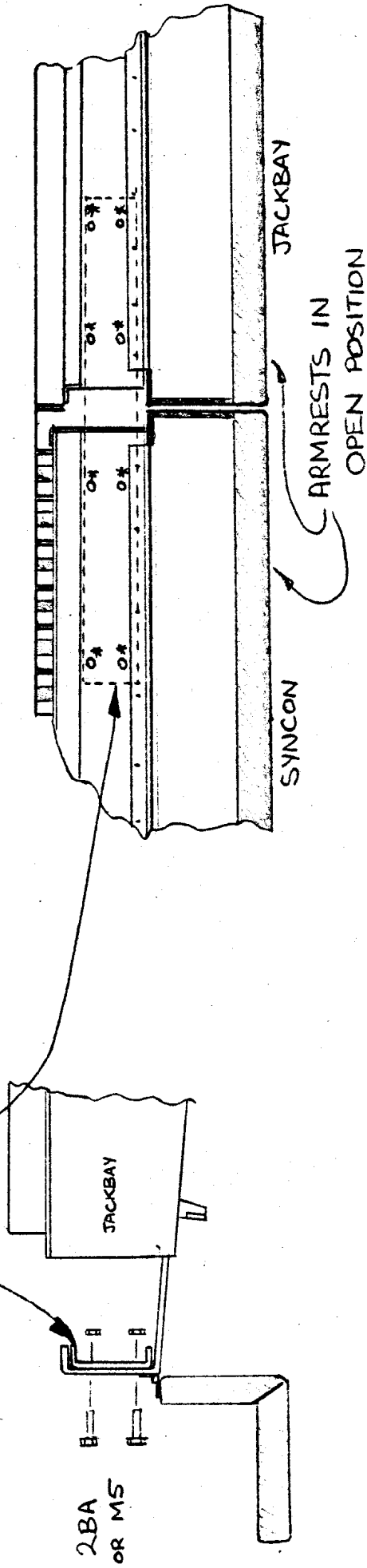

Allen and Heath Limited.

Pembroke House, Campsbourne Road.

London. N8, 7BR. Tel: 01-340-3291.

FITTING JACKBAY FRONT JOINER

FIG. 4

MA 3.10.78

ADD THIS
HEIGHT IF 5° TILT
USED
(SEE FIG 1.)

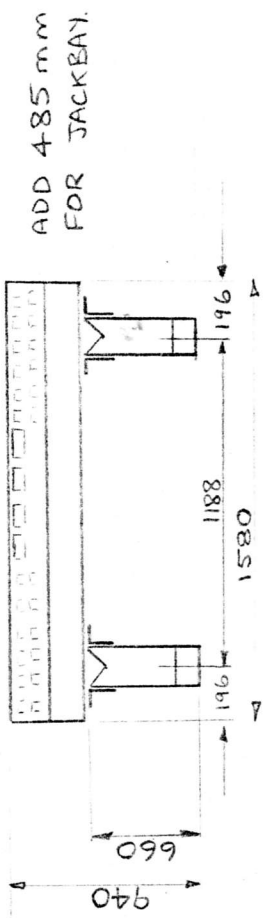

ADD 485 mm
FOR JACKBAY.

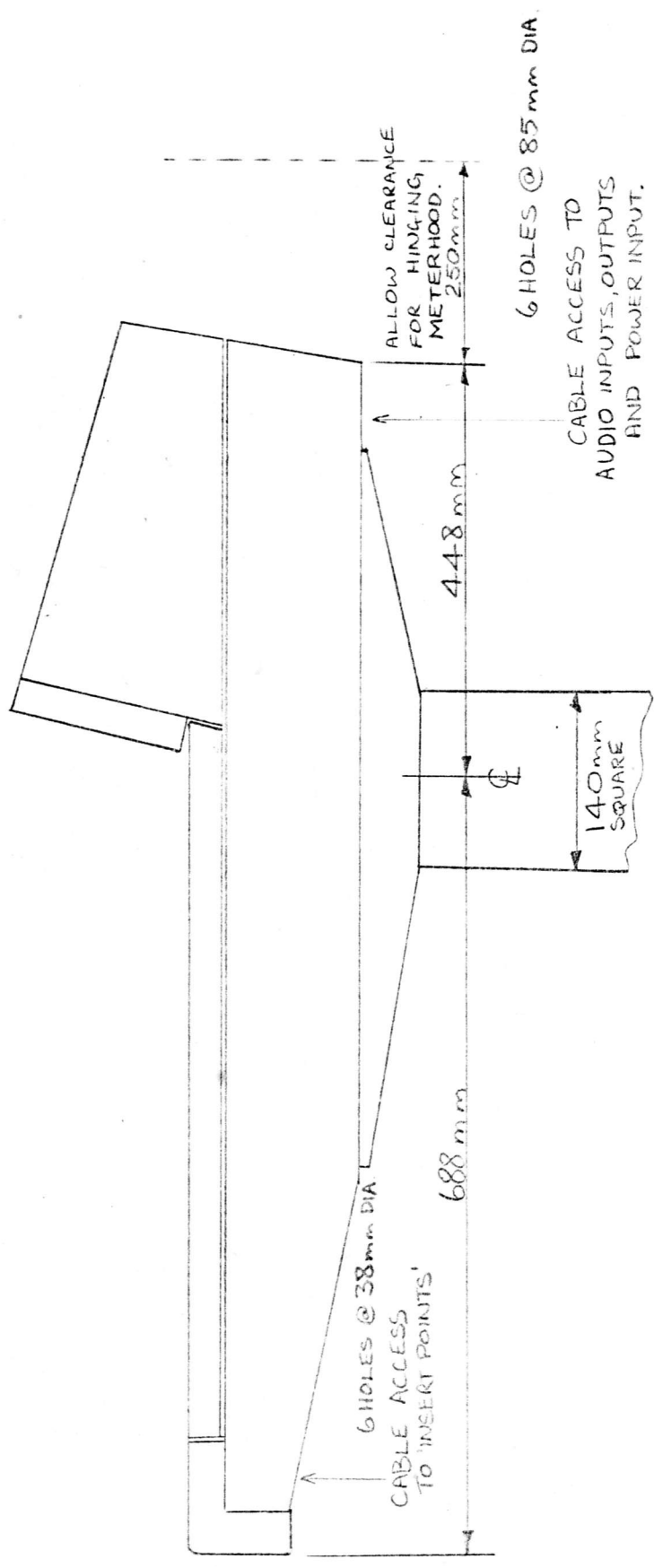

Allen and Heath Limited.
Pembroke House, Campsbourne Road.
London, N8, 7BR. Tel: 01-340-3291.

SYNCON STAND POSITIONS FOR CABLE DUCTING.

FIG. 5

MA 3-10-18

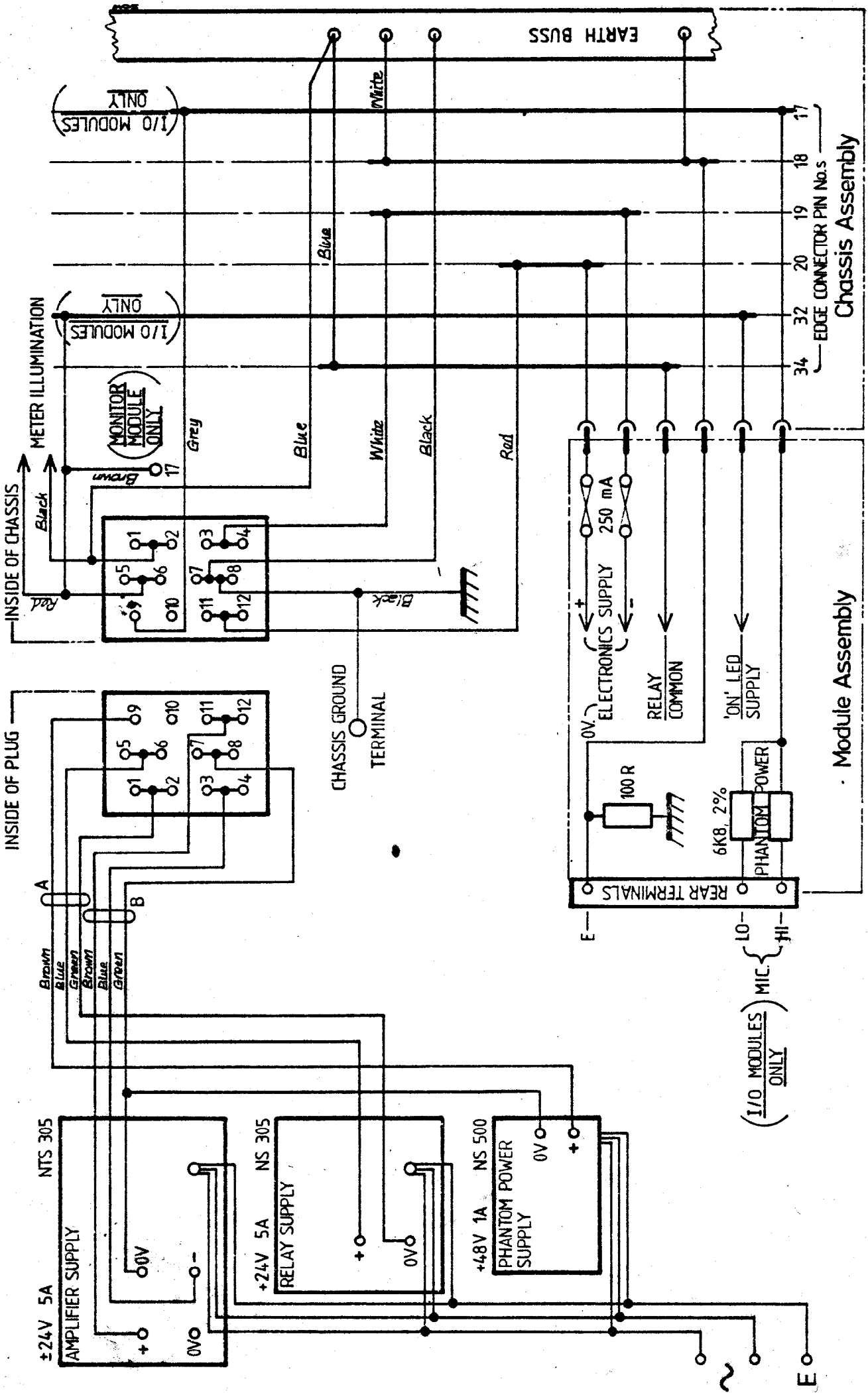



Q1-Q5 Q6, Q7

TRANSISTOR PINS
(VIEWED FROM PIN SIDE)

INVERTING INPUT

NON-INVERTING INPUT

TRANSISTORS	
No.	TYPE
Q1, Q2, Q3, Q5	ZTX 107 B
Q4	ZTX 212
Q6	BFR 40
Q7	BFR 80

— IN4148 or EQUIVALENT

ALL RESISTORS 1/4W. CARBON FILM 5%

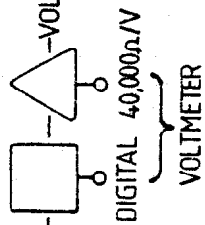

NO SIGNAL/D.C. CONDITIONS — — VOLTS W.R.T. POWER SUPPLY 0V.

DIGITAL 40,000n/V
VOLTMETER

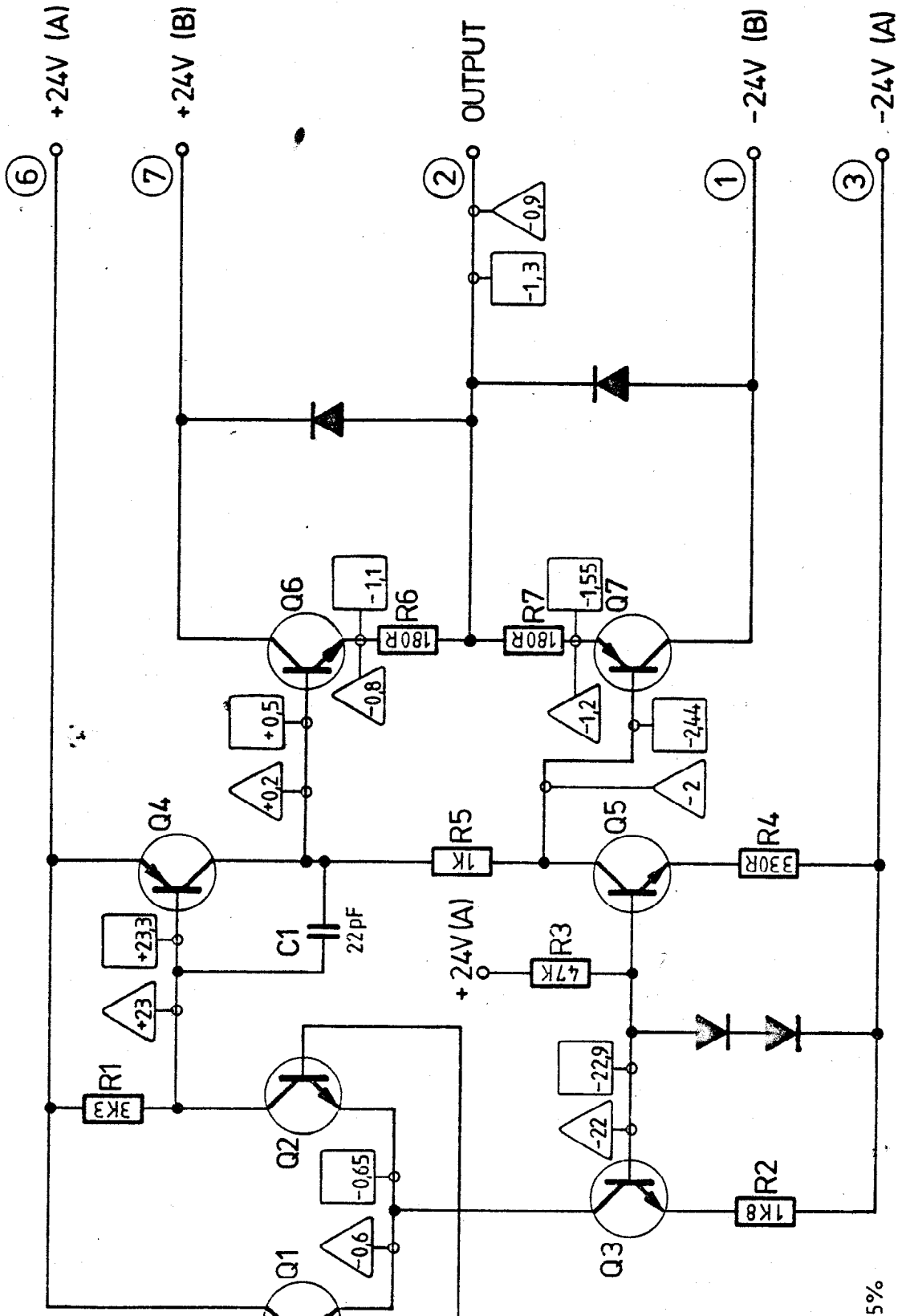

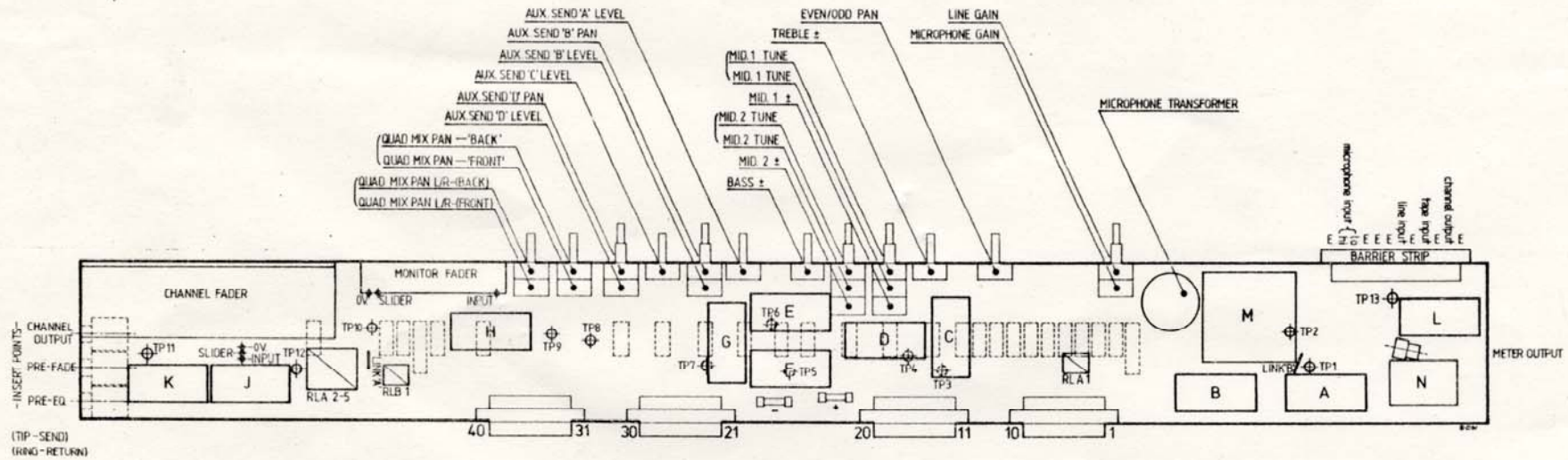

EDGE-CONNECTOR		PIN FUNCTIONS	
PIN	FUNCTION	PIN	FUNCTION
1	ROUTING BUSS SEND	1	1
2	" " "	2	2
3	" " "	3	3
4	" " "	4	4
5	" " "	5	5
6	" " "	6	6
7	" " "	7	7
8	" " "	8	8
9	" " "	9	9
10	" " "	10	10
11	" " "	11	11
12	" " "	12	12
13	" " "	13	13
14	" " "	14	14
15	" " "	15	15
16	" " "	16	16
17	+48V PHANTOM POWER INPUT	17	17
18	0V SIGNAL ELECTRONICS SUPPLY	18	18
19	-24V " " "	19	19
20	+24V " " "	20	20
		21	AUX A SUMMING BUSS
		22	" B LEFT " "
		23	" B RIGHT " "
		24	" E " "
		25	" D LEFT " "
		26	" D RIGHT " "
		27	QUAD 1 (LEFT FRONT) SUMMING BUSS
		28	0V SCREEN BUSS
		29	QUAD 2 (RIGHT FRONT) SUMMING BUSS
		30	QUAD SUMMING 0V
		31	QUAD 3 (LEFT BACK) SUMMING BUSS
		32	+24V LED SUPPLY
		33	QUAD 4 (RIGHT BACK) SUMMING BUSS
		34	0V RELAY SUPPLY
		35	MIXDOWN (RLA 1-5) DC CONTROL
		36	24T (HLB 1) DC CONTROL
		37	MONITOR SOLO DC CONTROL
		38	CHANNEL SOLO DC CONTROL
		39	LEFT SOLO SUMMING BUSS
		40	RIGHT " " "

LINK FUNCTION	
LINK	FUNCTION
A	MIXDOWN METER MODE
B	PHANTOM POWER

PLUG-IN AMPLIFIER MODULES	
AMP	FUNCTION
A	INPUT PREAMPLIFIER
B	CHANNEL MIX AMP 1st STAGE
C	EQUALISER AMP: TREBLE & MID 2 MIXER
D	" " " MID 1 TUNED AMPLIFIER
E	" " " BASS & MID 1 MIX OUTLINE AMP
F	" " " MID 2 TUNED AMPLIFIER
G	PRE EQ INSERTION RETURN BUFFER
H	MONITOR LINE AMPLIFIER
J	CHANNEL FADER LINE AMPLIFIER
K	CHANNEL MIX AMP 2nd STAGE
L	TAPE INPUT BUFFER
M	MICROPHONE PREAMP (ON MAIN CHAN BOARD)
N	METER AMPLIFIER " " " "

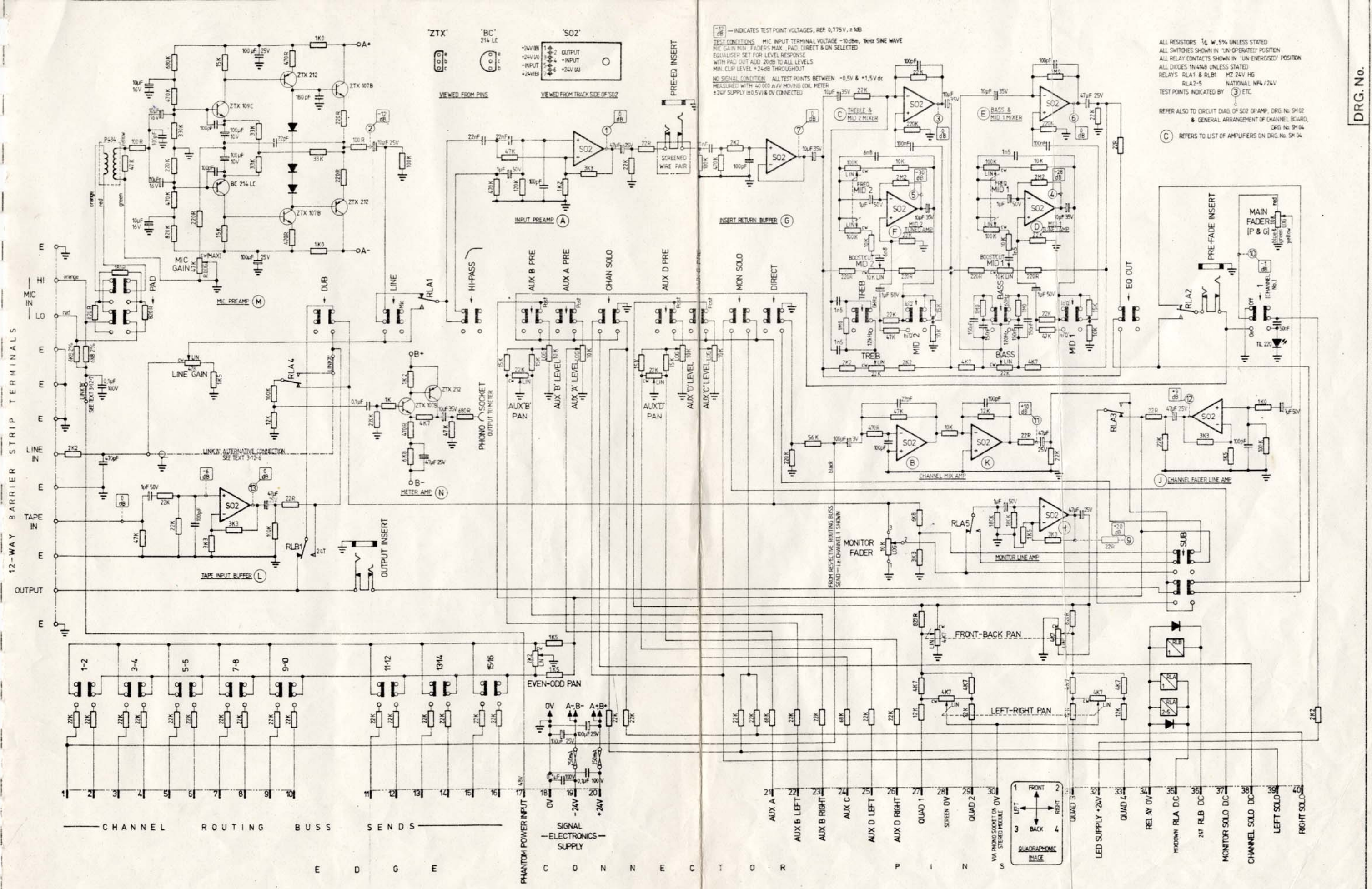

DRG. No.

EQ CUT SWITCH DRIVEN BY EQ INPUT BUFFER (C)	
SOLO SW OUTPUT WIPER, \pm N.C. SO2 AMP (L) ADDED	
UPDATED TO SC7	7-6-79
DESCRIPTION	CHKD APP'D DATE
ALTERATIONS	

SYNCON INPUT/OUTPUT MODULE - CIRCUIT DIAGRAM
 (SC7 SERIES CCT. BOARD)

Allen & Heath / Brenell Ltd.

DRAWN	TRACED	CHECKED	APPROVED	DATE	SCALE
S. C. W.		R	R	30.10.78	

DRAWING No. SC 02

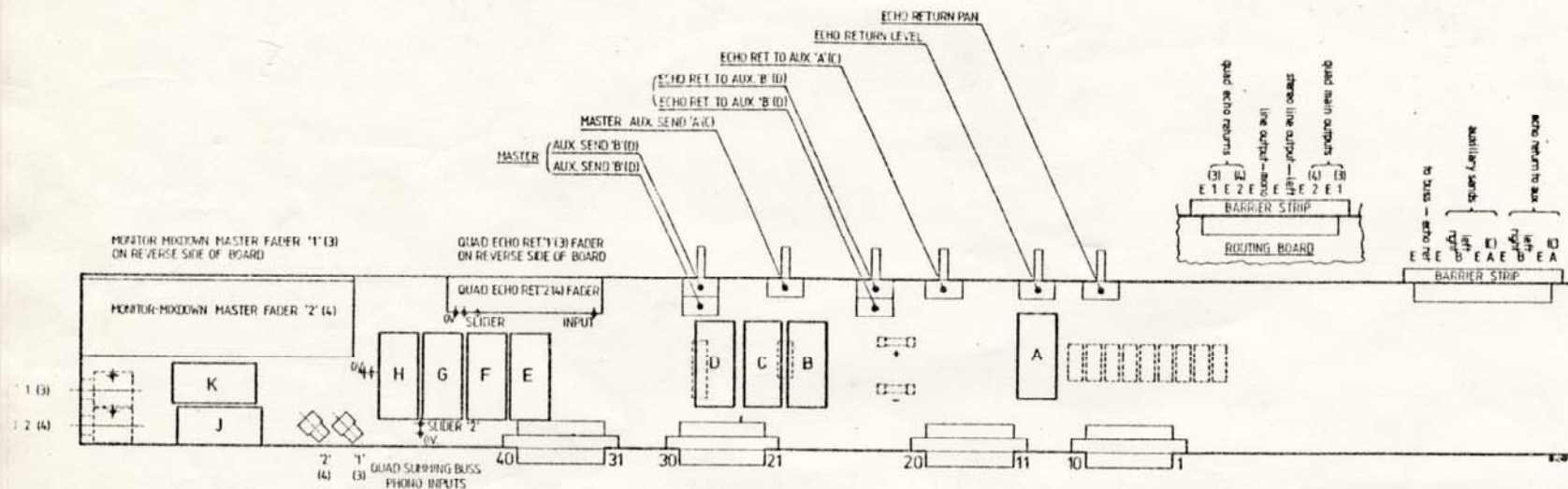

1 (3)
2 (4)

EDGE-CONNECTOR		PIN FUNCTIONS	
PIN	FUNCTION	PIN	FUNCTION
1	CHANNEL MIX BUSS 1	21	AUX 'A'(C) SLIPPING BUSS
2	" " " 2	22	" 'B'(D) LEFT " "
3	" " " 3	23	" 'B'(D) RIGHT " "
4	" " " 4	24	0V
5	" " " 5	25	"
6	" " " 6	26	"
7	" " " 7	27	QUAD MIX 1 SEND TO MONITOR MODULE
8	" " " 8	28	" " 2 " " " "
9	" " " 9	29	" " 3 " " " "
10	" " " 10	30	" " 4 " " " "
11	" " " 11	31	STEREO LEFT SEND TO MONITOR MODULE
12	" " " 12	32	" " RIGHT " " " "
13	" " " 13	33	MONO MIX SEND TO MONITOR MODULE
14	" " " 14	34	0V RELAY SUPPLY
15	" " " 15	35	N/C
16	" " " 16	35	"
17	N/C	37	MONITOR SOLD BY CONTROL
18	0V SIGNAL ELECTRONICS SUPPLY	38	N/C
19	-24V " " "	39	LEFT SOLO MIX BUSS
20	+24V " " "	40	RIGHT " " "

'LEFT-HAND' MODULE DEPICTED
 FIGURES IN PARENTHESIS APPLY TO 'RIGHT-HAND' MODULE.
 NB: ROUTING BOARD BARRIER STRIPS ARE DIRECTLY BEHIND
 RESPECTIVE MAIN BOARD BARRIER STRIPS

PLUG-IN AMPLIFIER MODULES	
AMP	FUNCTION
A	ECHO RETURN LINE AMPLIFIER
B	AUX 'A'(C) OUTPUT AMPLIFIER
C	AUX 'B'(D) LEFT OUTPUT AMPLIFIER
D	AUX 'B'(D) RIGHT OUTPUT AMPLIFIER
E	MONO MIX OUTPUT AMPLIFIER
F	STEREO MIX OUTPUT AMPLIFIER
G	QUAD MIX OUTPUT AMPLIFIER '2'(4)
H	" " " " '1'(3)
J	QUAD MIX AMPLIFIER '2'(4)
K	" " " " '1'(3)

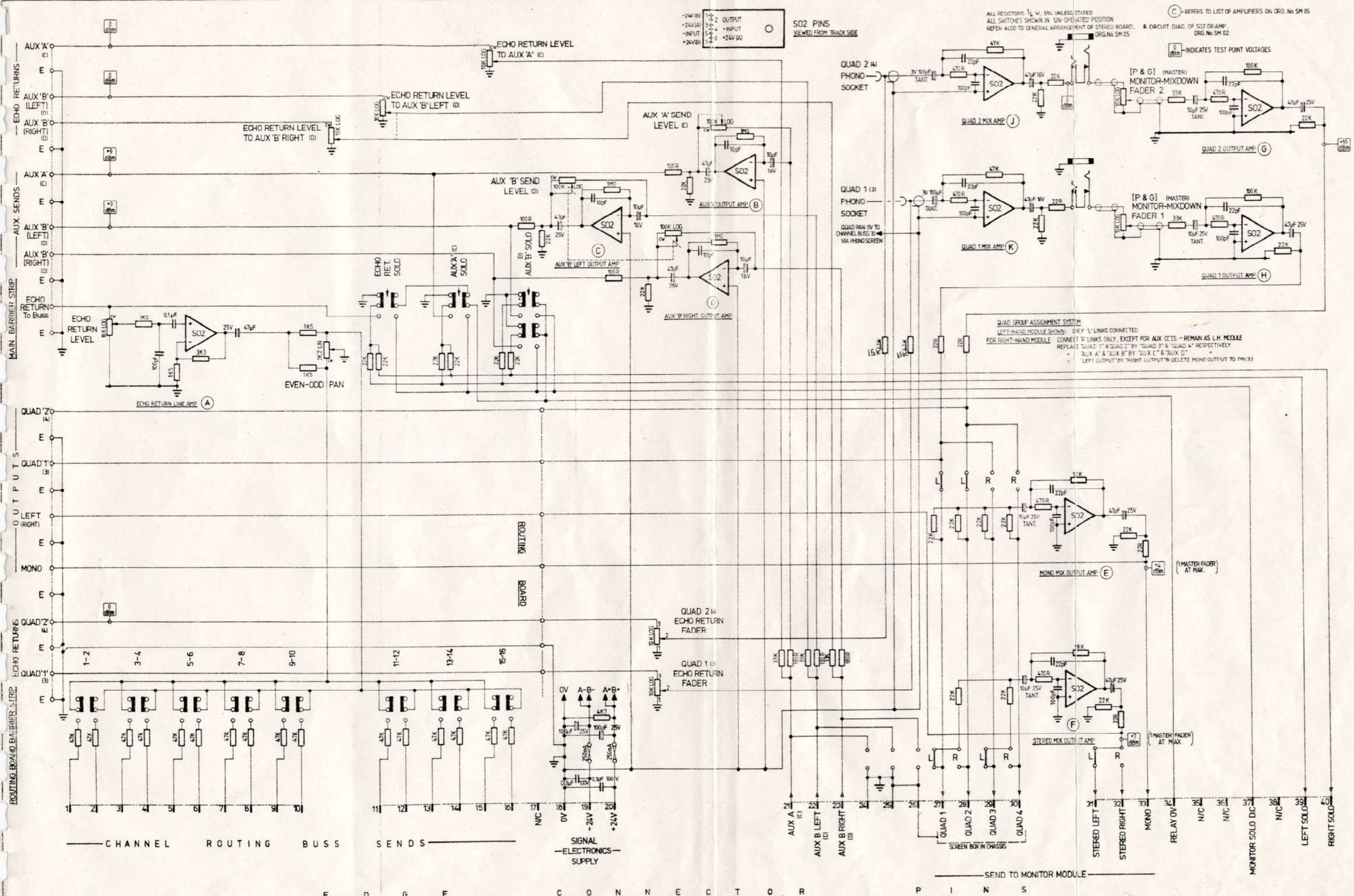

ALL SOLD SWITCHES CHANGED TO DP-WIPER, $\text{NC} = \text{N.C.}$	CHK'D APP'D DATE
ALTERATIONS	

SYNCON STEREO/QUAD MASTER MODULE - CIRCUIT DIAGRAM
 (ONLY ONE MODULE OF TWO SHOWN - REFER TO NOTES)

Allen & Heath/Brenell Ltd.

DRAWN	TRACED	CHECKED	APPROVED	DATE	SCALE
S.C.W		R		28-11-78	

DRAWING No. SC 03

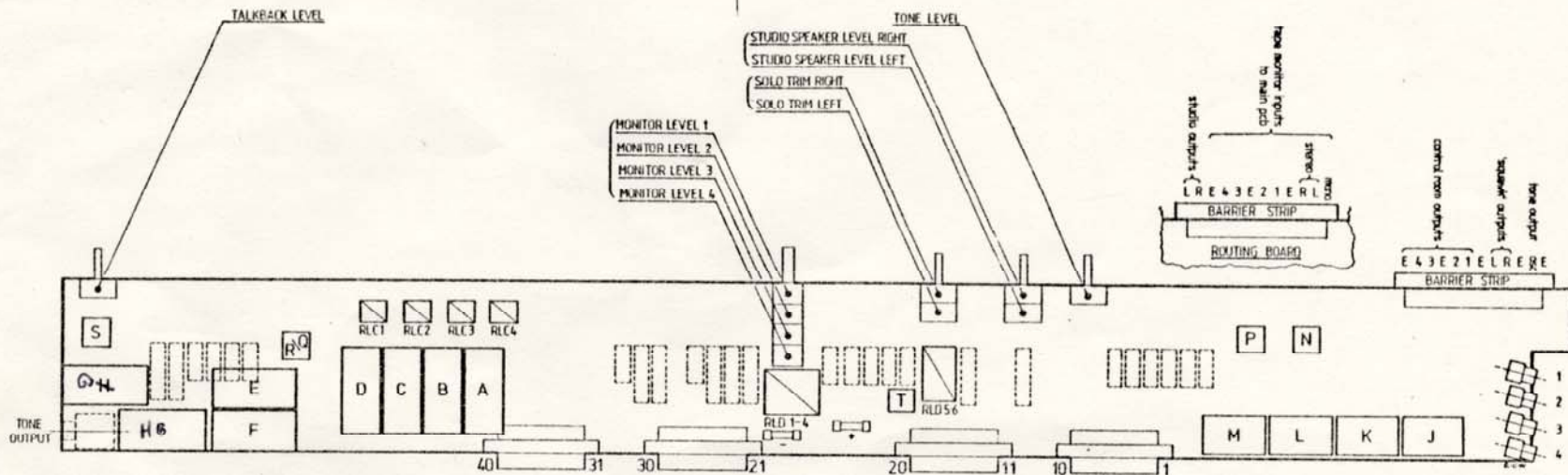

EDGE-CONNECTOR PIN FUNCTIONS			
PIN	FUNCTION	PIN	FUNCTION
1	CHANNEL MIX BUSS 1	21	TALKBACK TO AUX 'A'
2	" " " 2	22	" " " " " 'B'
3	" " " 3	23	" " " " " 'C'
4	" " " 4	24	TALKBACK TO AUX 'D'
5	" " " 5	25	" " " " " 'D'
6	" " " 6	26	0V
7	" " " 7	27	QUAD MIX 1 INPUT
8	" " " 8	28	" " " 2 "
9	" " " 9	29	" " " 3 "
10	" " " 10	30	" " " 4 "
11	" " " 11	31	STEREO MIX LEFT INPUT
12	" " " 12	32	" " " RIGHT "
13	" " " 13	33	MONO MIX INPUT
14	" " " 14	34	0V RELAY SUPPLY
15	" " " 15	35	MIX/DUAL TRIA 1-51 DC CONTROL
16	" " " 16	36	24T (RI B 1) DC CONTROL
17	+24V RELAY SUPPLY	37	MONITOR SOLO DC CONTROL
18	0V SIGNAL ELECTRONICS SUPPLY	38	CHANNEL SOLO DC CONTROL
19	-24V " " "	39	LEFT SOLO MIX INPUT
20	+24V " " "	40	RIGHT " " "

NB: ROUTING BOARD BARRIER STRIP IS DIRECTLY BEHIND MAIN BOARD BARRIER STRIP

'ON-BOARD' AMPLIFIERS	
AMP	FUNCTION
J	METER AMP 1
K	" " " 2
L	" " " 3
M	" " " 4
N	TONE AMPLIFIER
P	TONE OSCILLATOR
Q	2"Hz SLATE TONE GEN.
R	TALKBACK PREAMPLIFIER
S	" " MIXER
T	SOLO RELAY DRISGER

PLUG-IN AMPLIFIER MODULES	
AMP.	FUNCTION
A	MONITOR LINE AMP 4
B	" " " 3
C	" " " 2
D	" " " 1
E	SOLO MIX AMP RIGHT
F	" " " LEFT
G	STUDIO LINE OUTPUT AMP RIGHT
H	" " " " LEFT

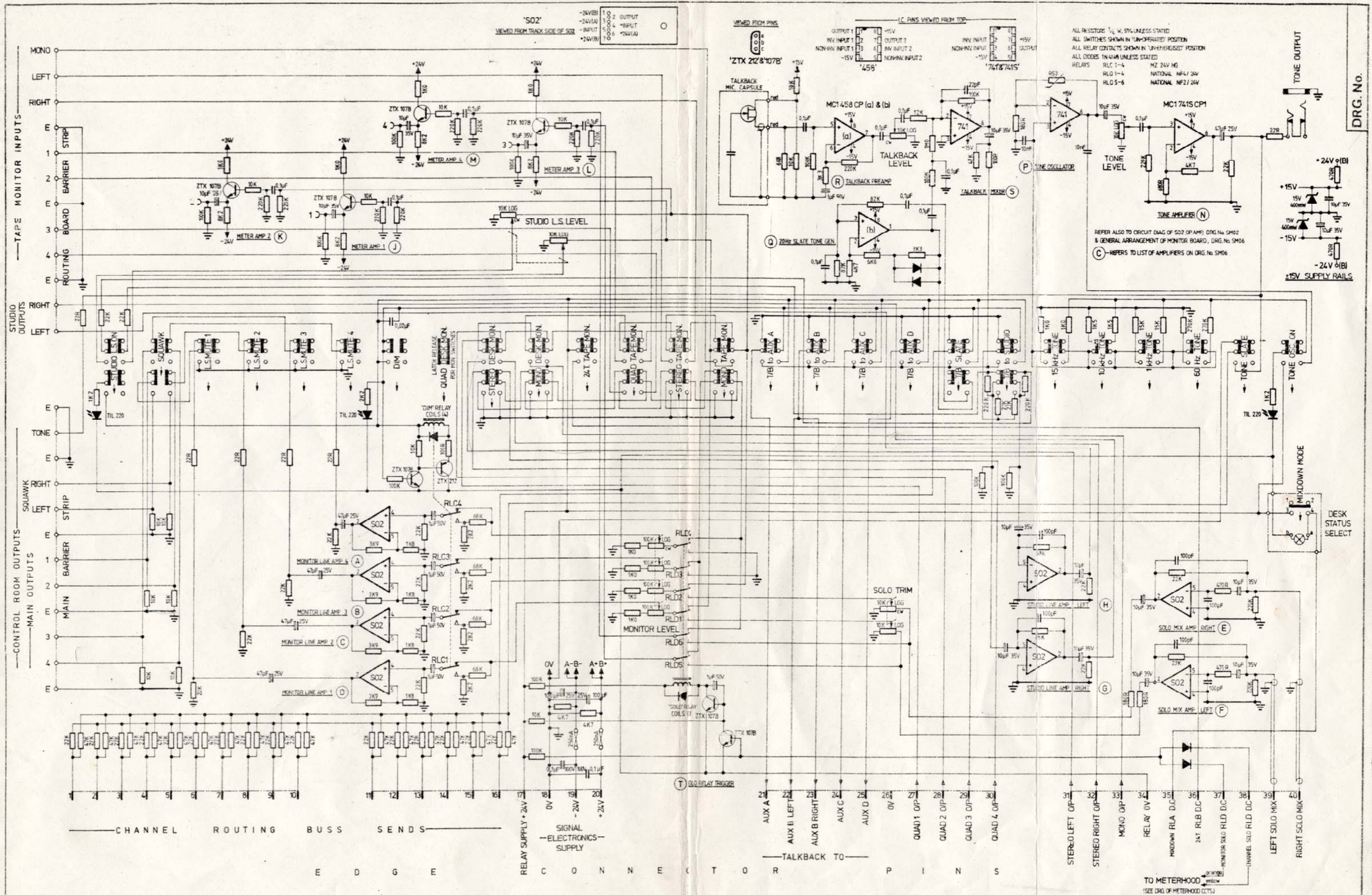

DRG. No.

No.	DESCRIPTION	CHK'D/APP'D	DATE
ALTERATIONS			

SYNCON MONITOR MODULE — CIRCUIT DIAGRAM

Allen & Heath / Brenell Ltd.

DRAWN	TRACED	CHECKED	APPROVED	DATE	SCALE
S.C.W.				20-12-78	

DRAWING No. SC 04

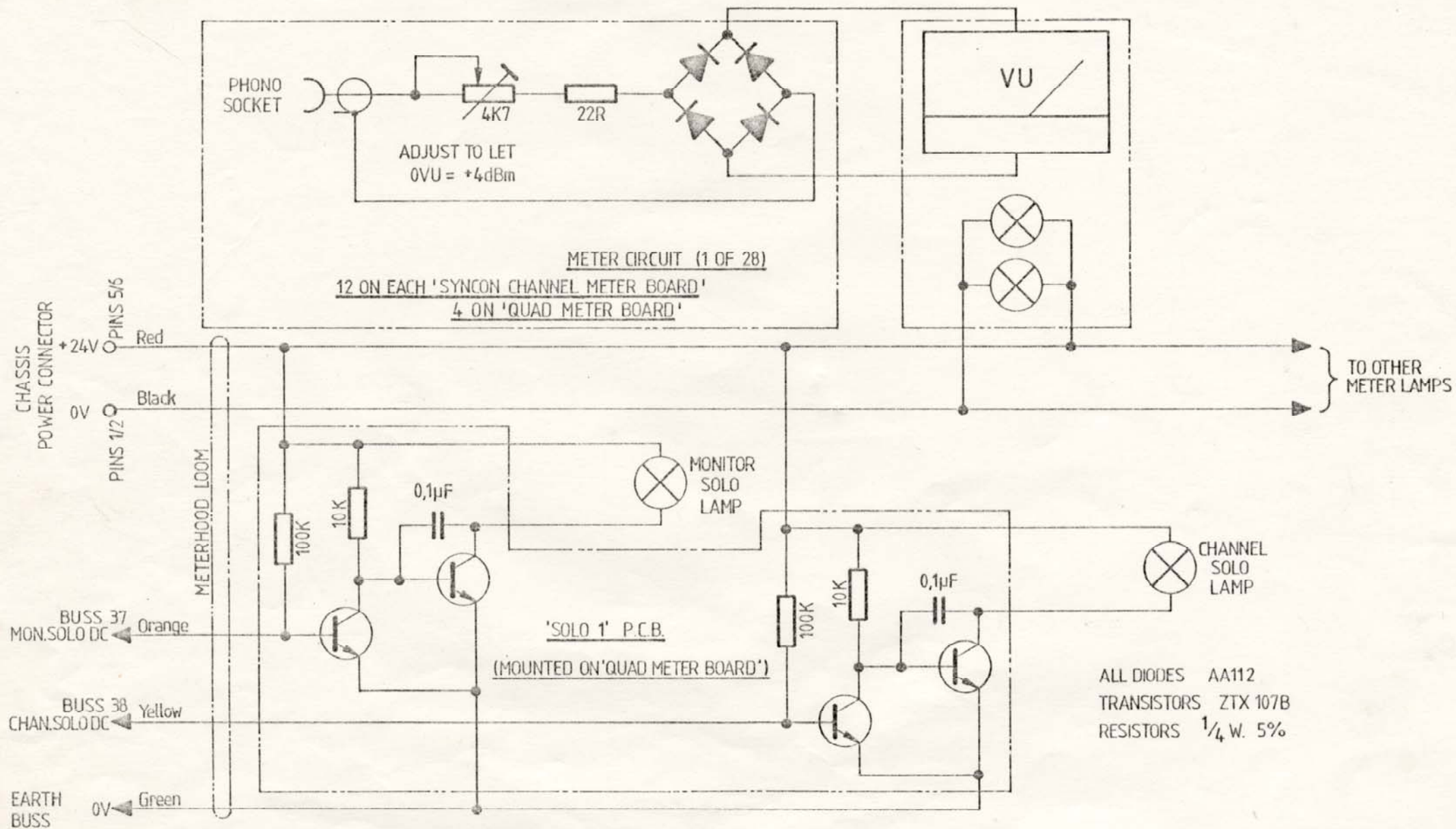

METERHOOD CIRCUIT DIAGRAM

SYNCON

SM 08

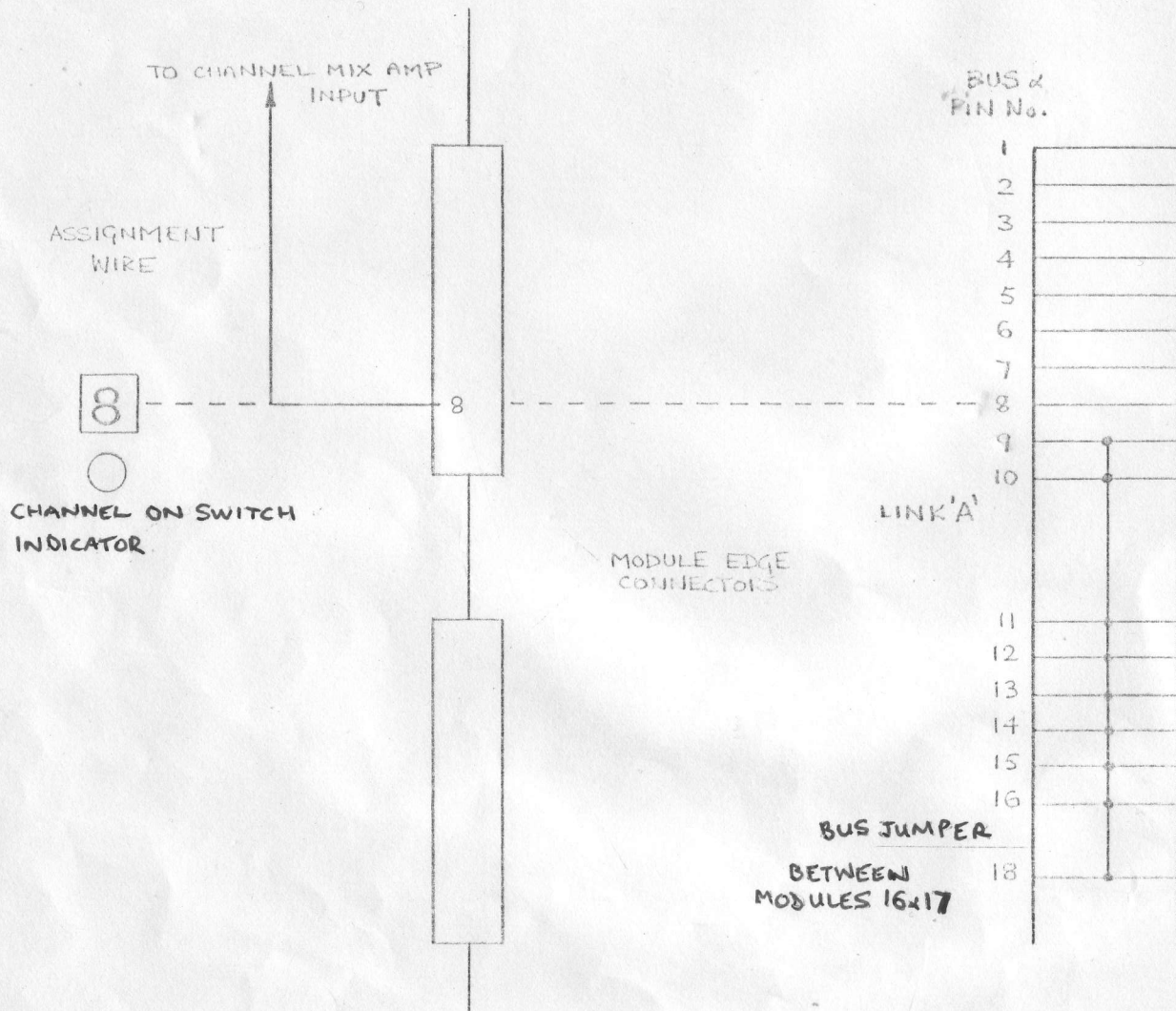

DIAGRAM
 JUMPER STANDARD FORMAT,
 MODIFIED FOR USE WITH
 CONSOLES HAVING LESS THAN
 SIXTEEN CHANNEL MODULES.
 EIGHT CHANNEL VERSION SHOWN,
 WHEN ADDING CHANNEL NINE
 REMOVE LINK 'A' FROM LINK NINE
 ON THE BUS JUMPER, ALSO
 CHECK THAT MODULE ASSIGNMENT
 WIRE TERMINATES ON EDGE -
 CONNECTOR PIN NINE.

SYNCON : CHANNEL ASSIGNMENT & BUS JUMPER : CONSOLE LESS THAN 16 CHANNELS.