

Service *Manual*

**MODEL: PBM8.250 MKII
PBM8.500 MKII**

CONTENT

1. Introduction.....	1
2. Specification.....	2
3. Block Diagram.....	4
4. Schematic Diagram.....	5
5. Wiring Diagram.....	19
6. PCB Layout.....	20
7. Test Procedure.....	36
8. Exploded View & Mechanical Parts List.....	37
9. BOM.....	40

1. Introduction

MODEL NO:PBM8.250 MKII

FEATURE:

- 2X250 Watts at 4 Ohms RMS EIAJ
- One stereo and one mono graphic EQ
- Digital effects with with 256 effects
- Feedback locator on both MAIN and MONITOR output
- 8 XLR inputs with 48 Volt phantom power
- One tape input channel assignable to MAIN or to CH9-10
- Each channel has 3-band EQ, one monitor, one effect send, one line, and one XLR input
- Two stereo channels
- Stereo or Monitor/Main mode
- RCA L/R tape in and L/R tape out

MODEL NO:PBM8.500 MKII

FEATURE:

- 2X250 Watts at 4 Ohms RMS EIAJ
- One stereo and one mono graphic EQ
- Digital effects with with 256 effects
- Feedback locator on both MAIN and MONITOR output
- 8 XLR inputs with 48 Volt phantom power
- One tape input channel assignable to MAIN or to CH9-10
- Each channel has 3-band EQ, one monitor, one effect send, one line, and one XLR input
- Two stereo channels
- Stereo or Monitor/Main mode
- RCA L/R tape in and L/R tape out

2. Technical Specification

Mono input channels		
	Microphone input	Electronically balanced, discrete input configuration
	Frequency response	10Hzto55kHz,+3dB
	Distortion(THD&N)	0.006%at4dBu,1kHz
	Gain	50dB(MIC)
	SNR(Signal to Noise Ratio)	>90dB
	Line input	Electronically balanced
	Frequency response	10Hz to 55kHz, 3dB
	Distortion (THD&N)	0.04% at 4dBu,1kHz
	Gain	30dB
Stereo input channels		
	Line input	Unbalanced
	Frequency response	10Hz to 55kHz, 3dB
	Distortion (THD&N)	0.006% at +4dBu, 1kHz
Impedances		
	Microphone input	1.4kOhm
	Stereo return	2.5kOhm
	All other inputs	10kOhm or greater
	Tape out	1kOhm
	All other output	120 Ohm
Equalization		
	Hi shelving	+/- 15dB@12kHz
	Mid bell	+/- 15dB@2.5kHz
	Low shelving	+/- 15dB@80Hz
DSP Section		
	A/D and D/A converters	24 bit
	DSP resolution	24 bit
	Type of effects	Hall, Room, Vocal & Plate REVERBS
		Mono & Stereo DELAY (max DELAYTIME 650ms)
		Chorus, Flanger & Reverb MODULATIONS
		REVERB+DELAY, REVERB+CHORUS,
		REVERB+FLANGER combinations
	Presets	256
	Controls	16-position PRESET Selector
		16-position VARIATION selector
		CLIP LED
		MUTE SWITCH with LED indicator

Main Mix Section		
	Noise (Bus noise)	Fader 0dB, channels muted:85dBr (ref.: +4dBu)
		Fader 0dB,all input channels assigned and set to
		UNITY gain:71dBr (ref.: +4dBu)
	Max output	+27dBu balanced, +22dBu unbalanced, 1/4" jacks
	AUX Sends max out	+22dBu
Power supply		
	Main voltage	100VAC~60Hz 230VAC~50Hz 120VAC~60Hz 240VAC~50Hz
	Power Consumption	
		PBM8.250MKII Stereo mode: 250W@4ohm 190W@8ohm
		Bridge mode: 500W@8ohm 300W@8ohm
		Bridge mode: 1000W@8ohm
	Fuse	
		PBM8.250MKII 100~120V:T6.3AL 210~240V:T3.15AL
		PBM8.500MKII 100~120V:T10AL 210~240V:T6.3AL
Physical		
	Dimension(W × D × H)	550mm × 220mm × 310mm (8.66" × 12.20" × 21.65")
	Weight	
		PBM8.250MKII (Net): 14kg(30.86lb) (Gross): 15kg(33.07lb)
		PBM8.500MKII (Net):15kg(33.07lb) (Gross):16kg(35.27lb)

3. Block Diagram

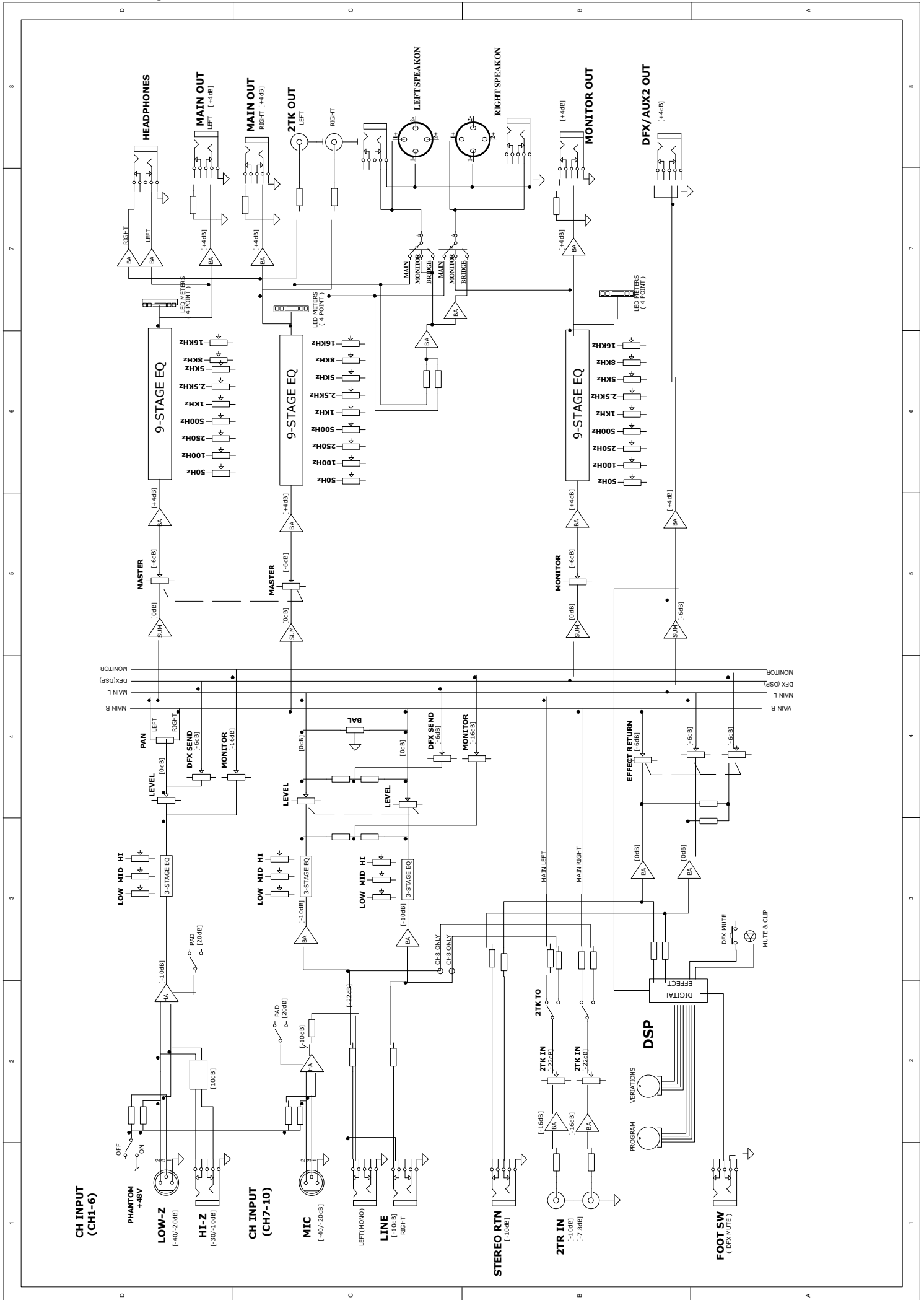

4. Schematic Diagram

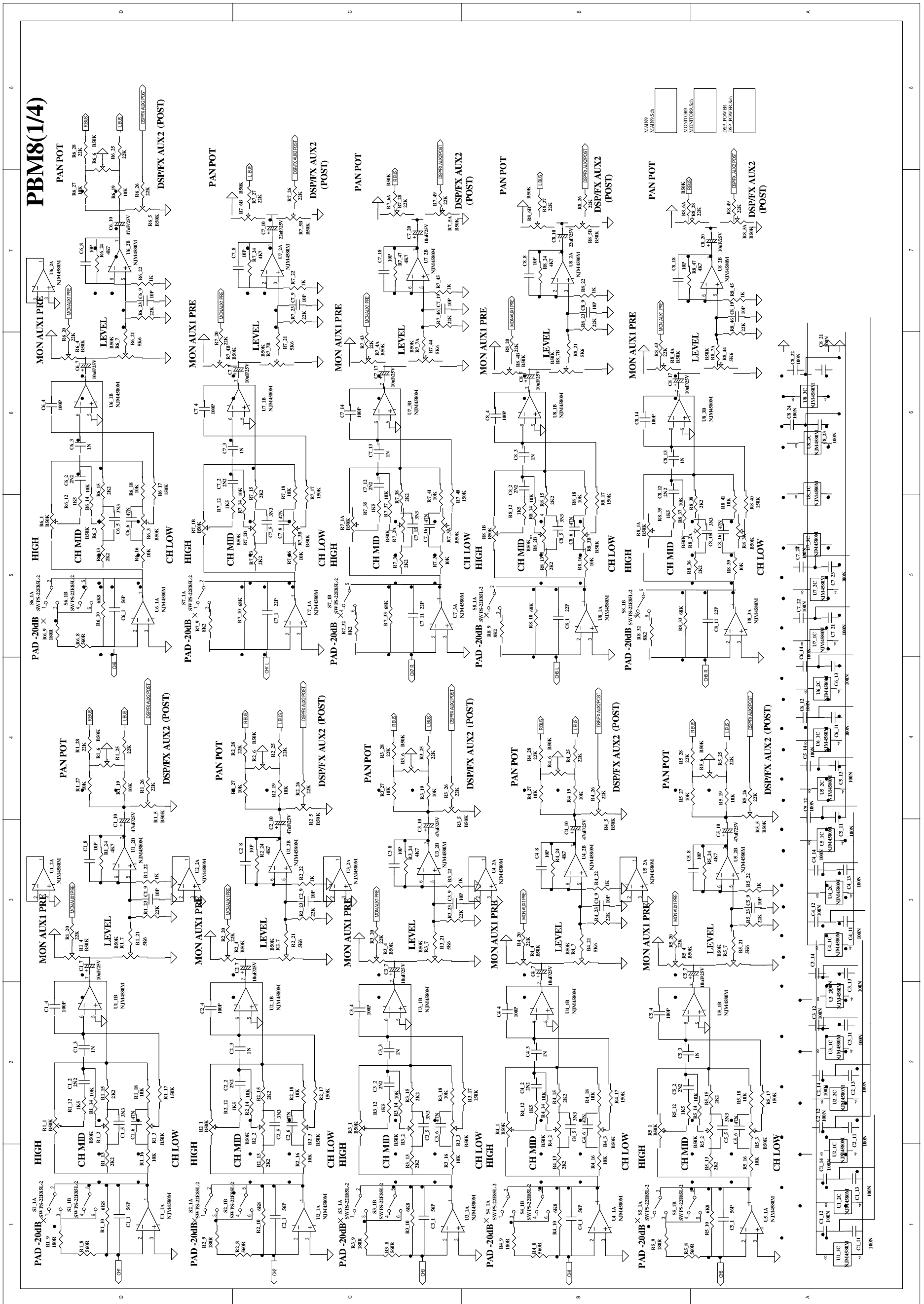

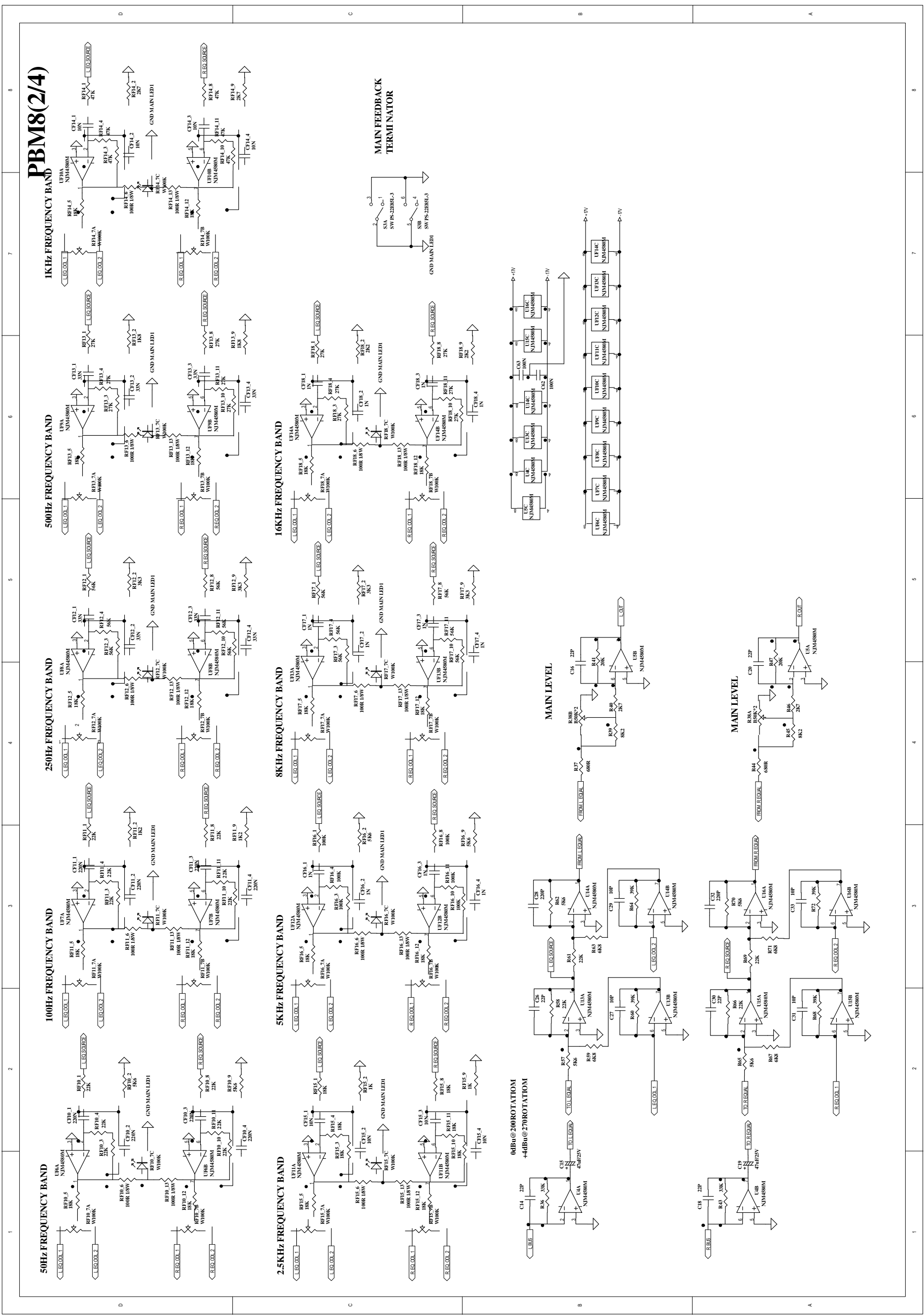

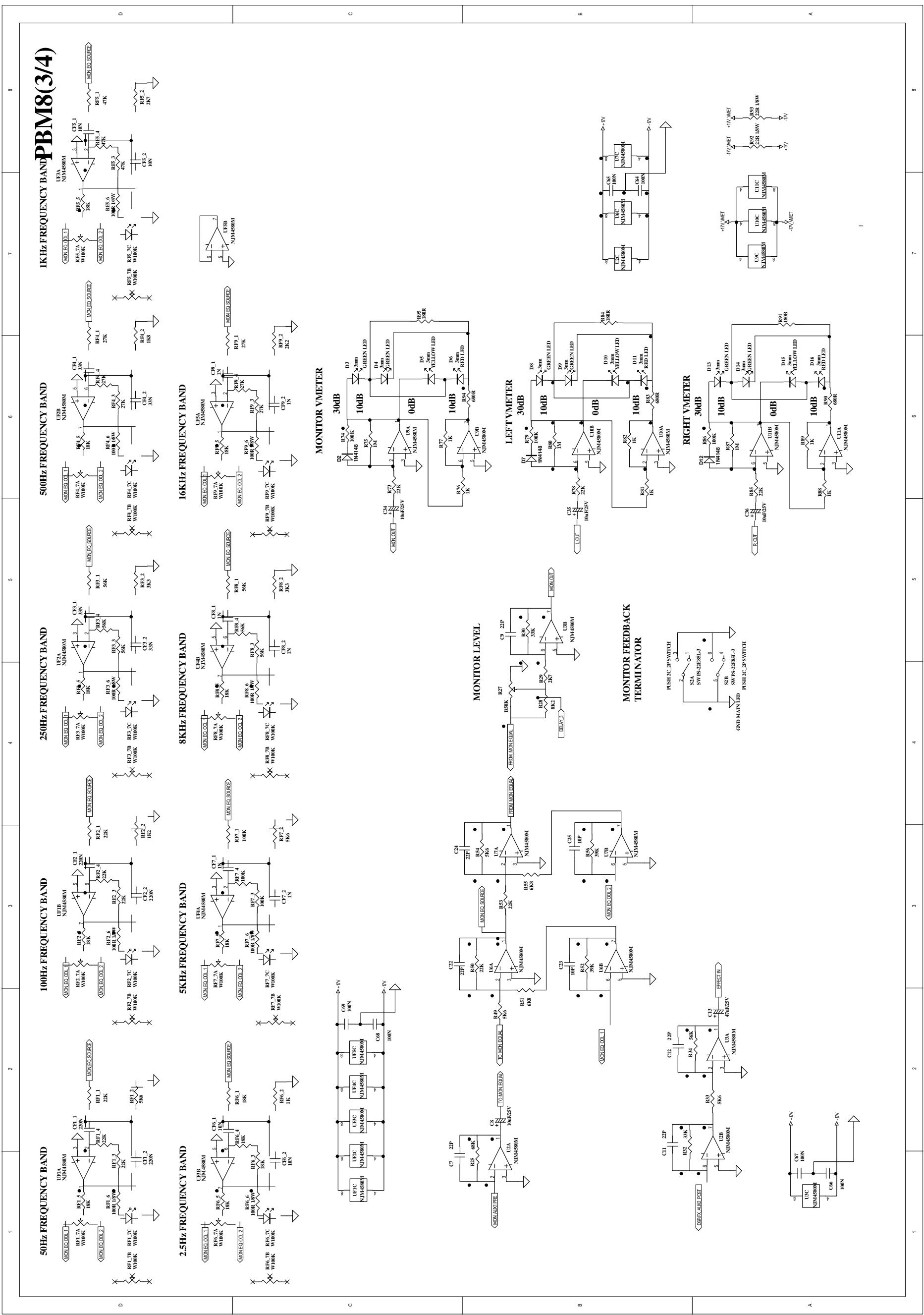

PBM8(4/4)

DSP MUTE

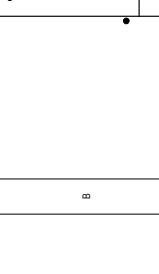
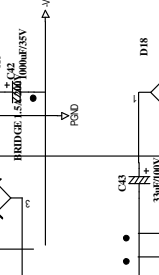
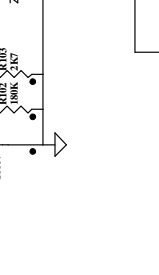
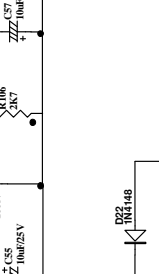
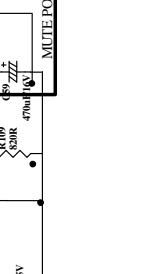
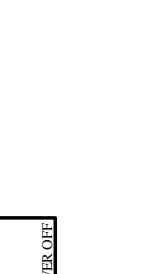
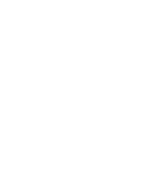
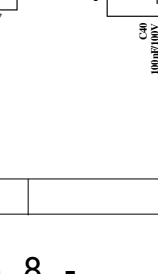
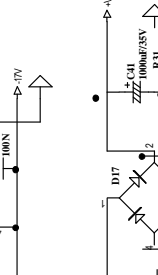
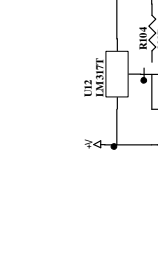
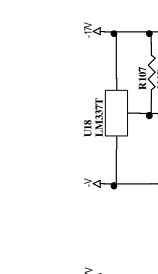
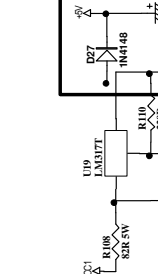
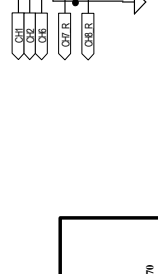
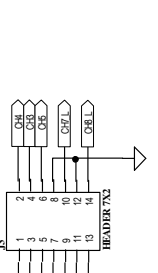
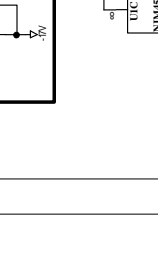
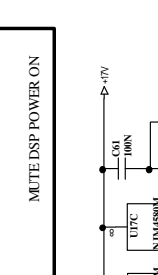
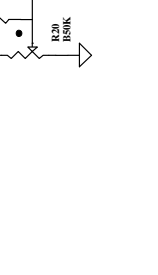
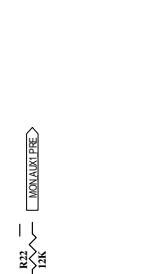
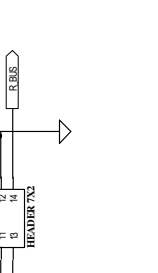
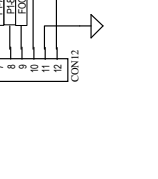
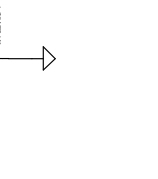
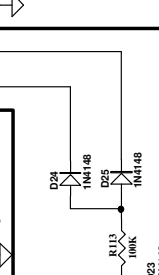
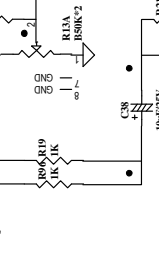
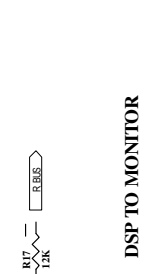
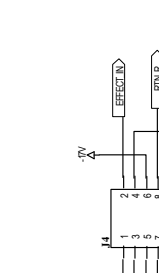
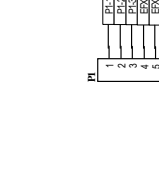
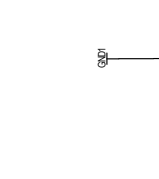
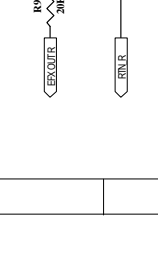
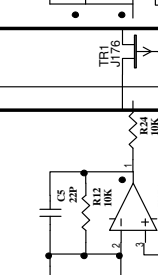
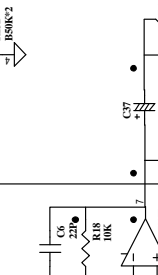
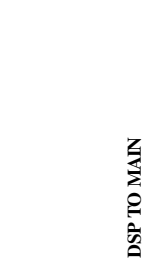
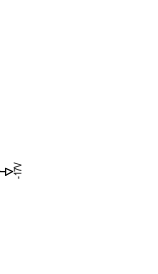
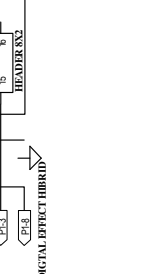
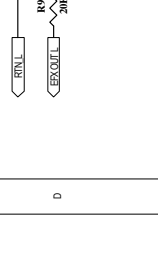
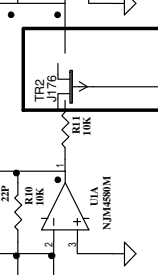
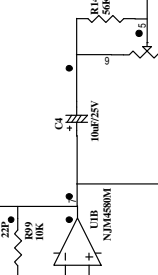
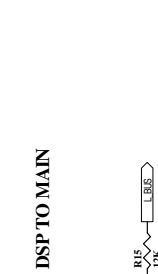
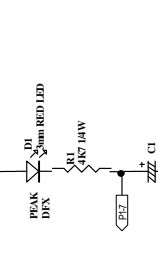
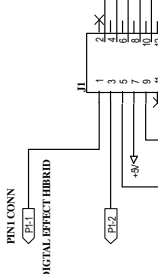
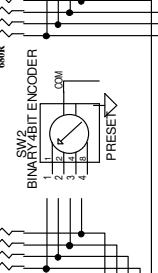
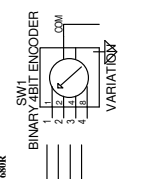
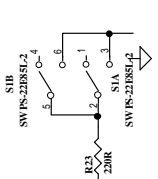

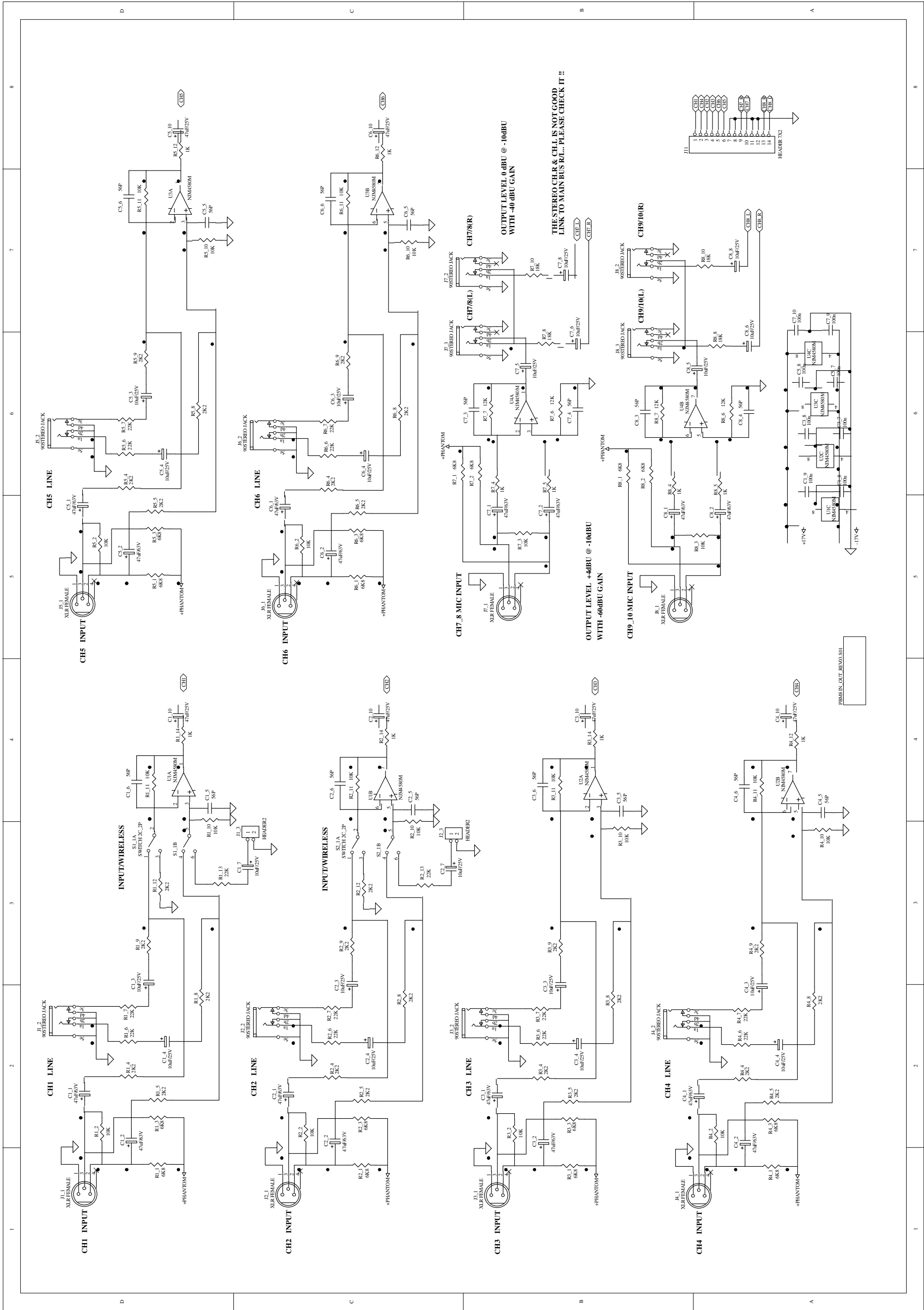

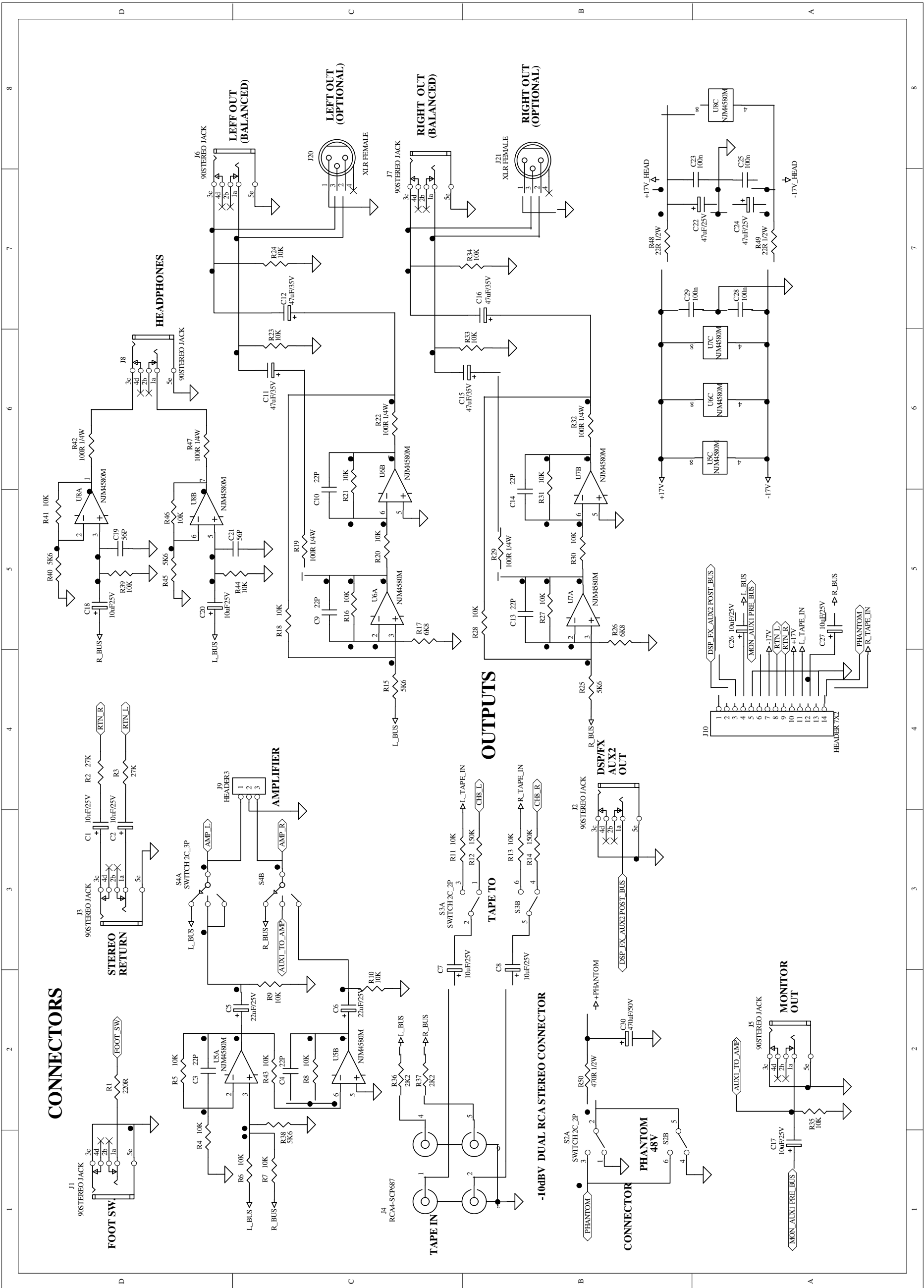

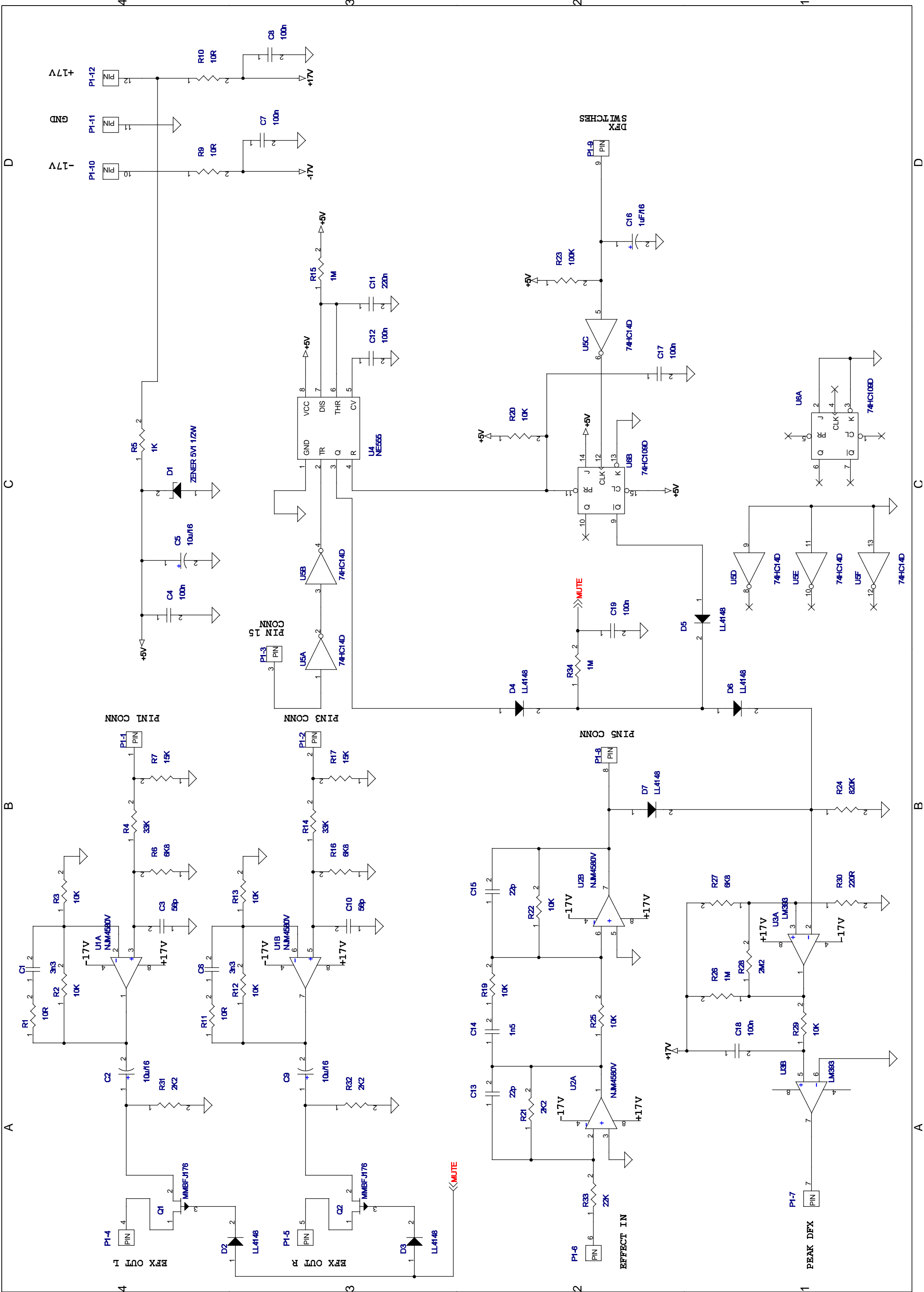

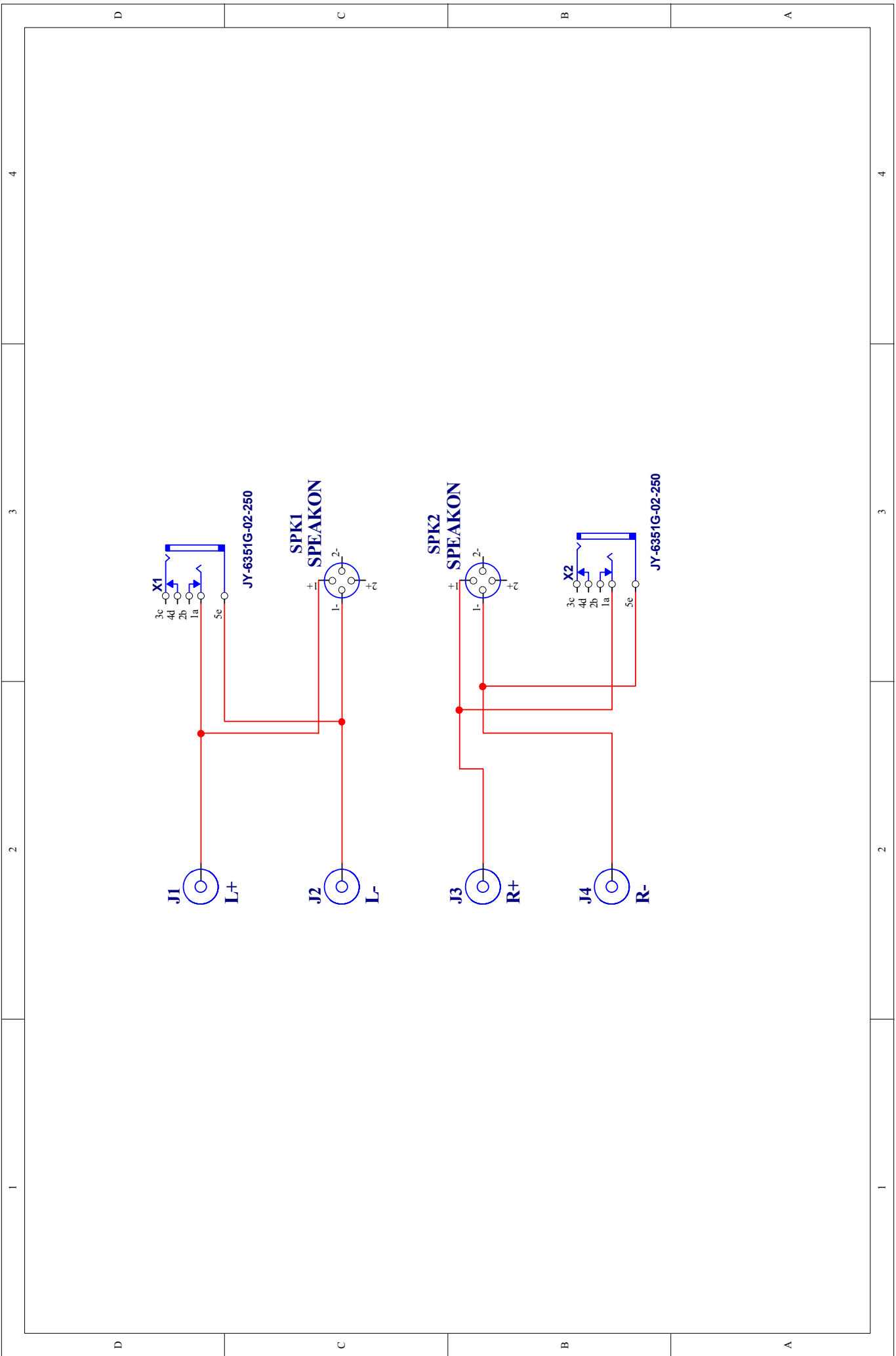

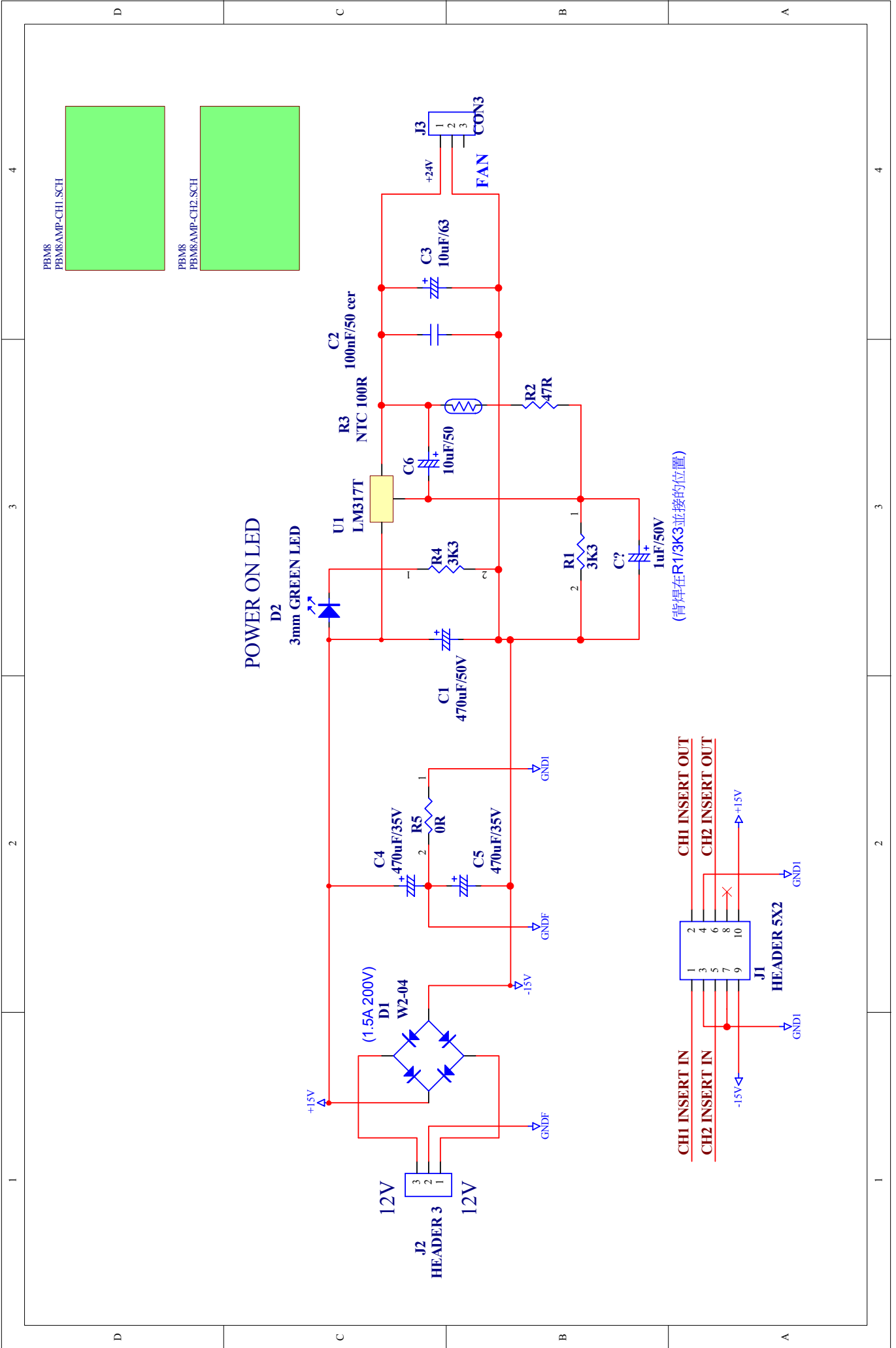

POWER ON LED

D2
3mm GREEN LED

(背焊在R1/3K3並接的位置)

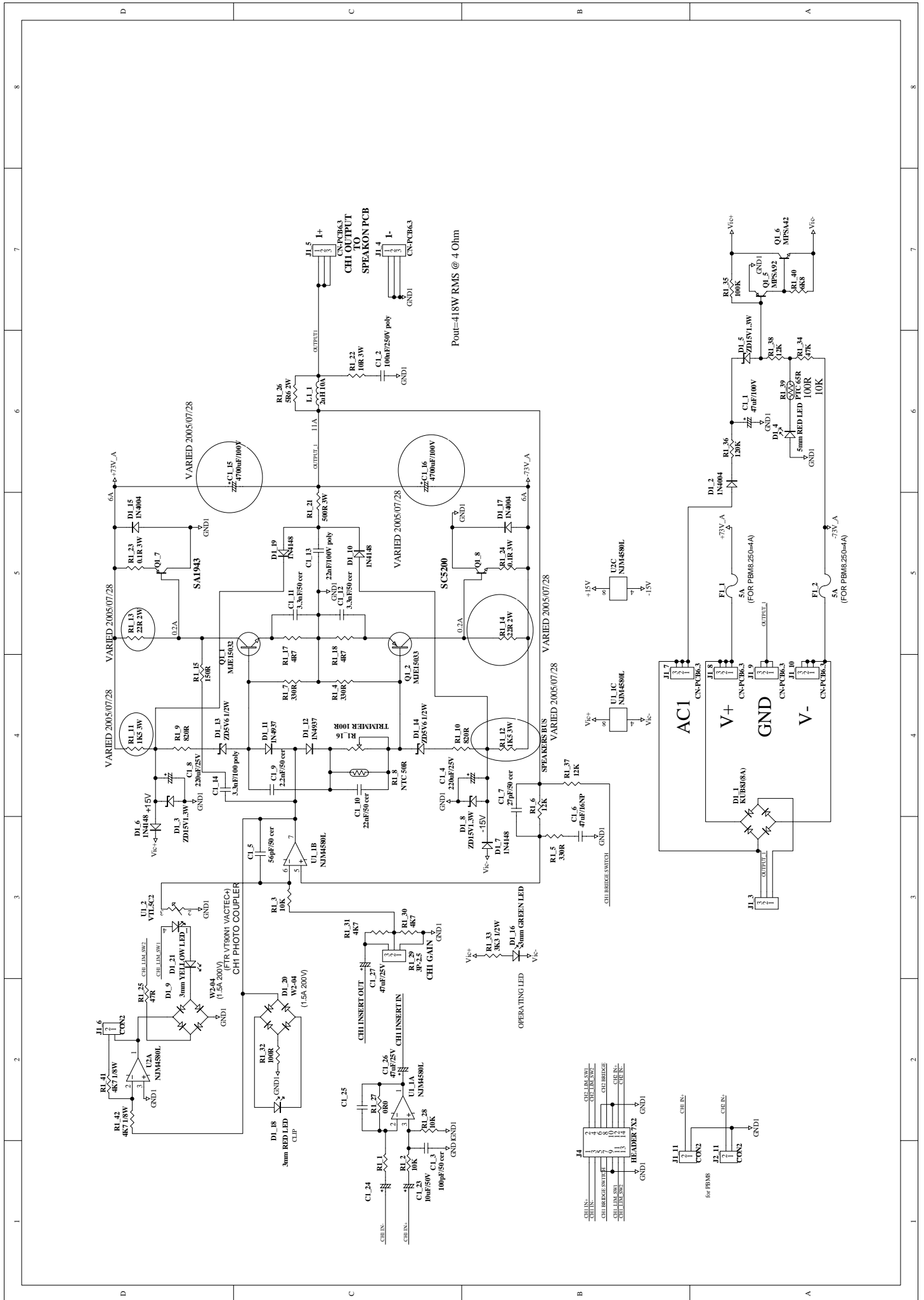

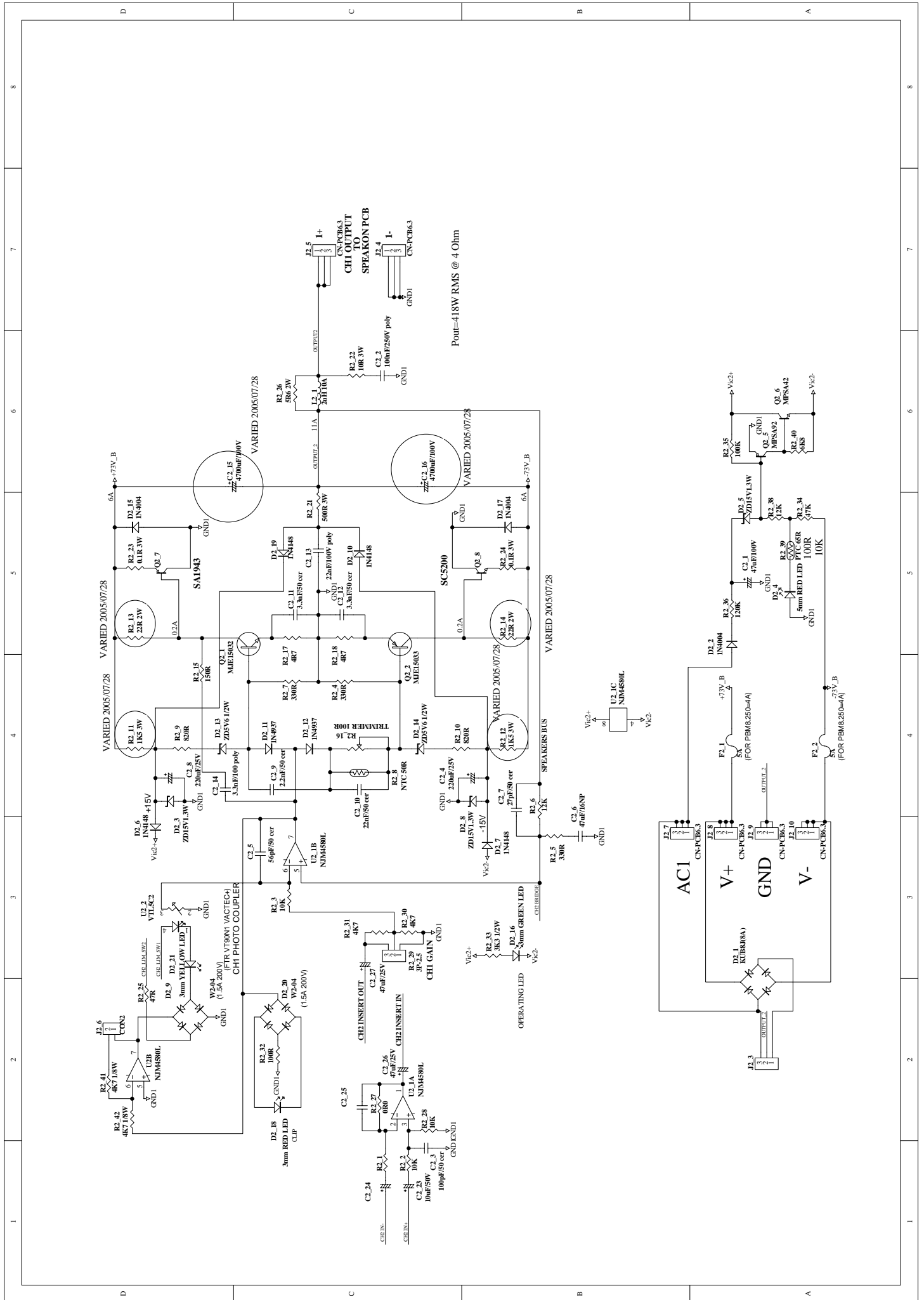

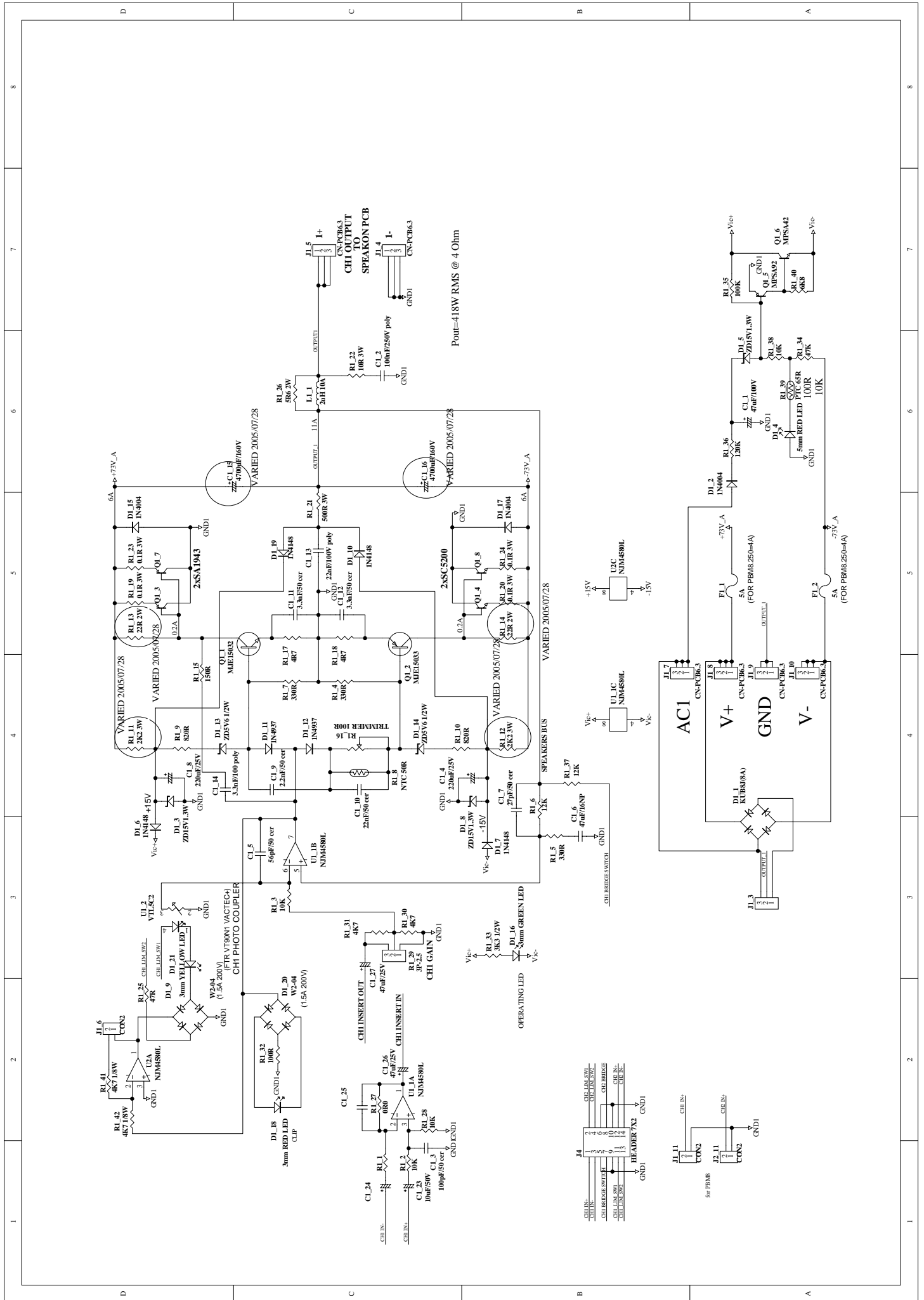

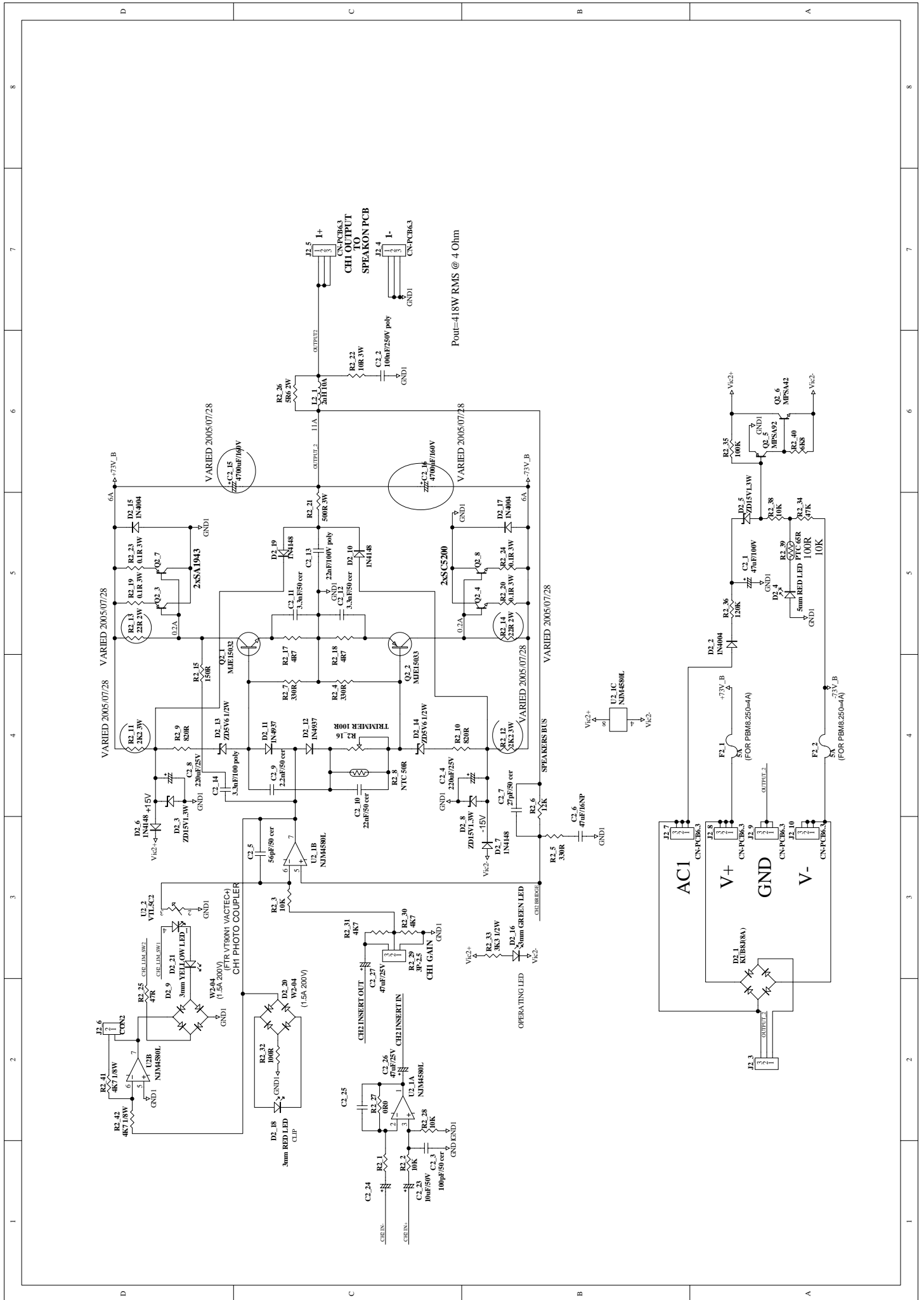

Change values of R5,7,8,9,10,11,12,13 to 1.5K (030326).

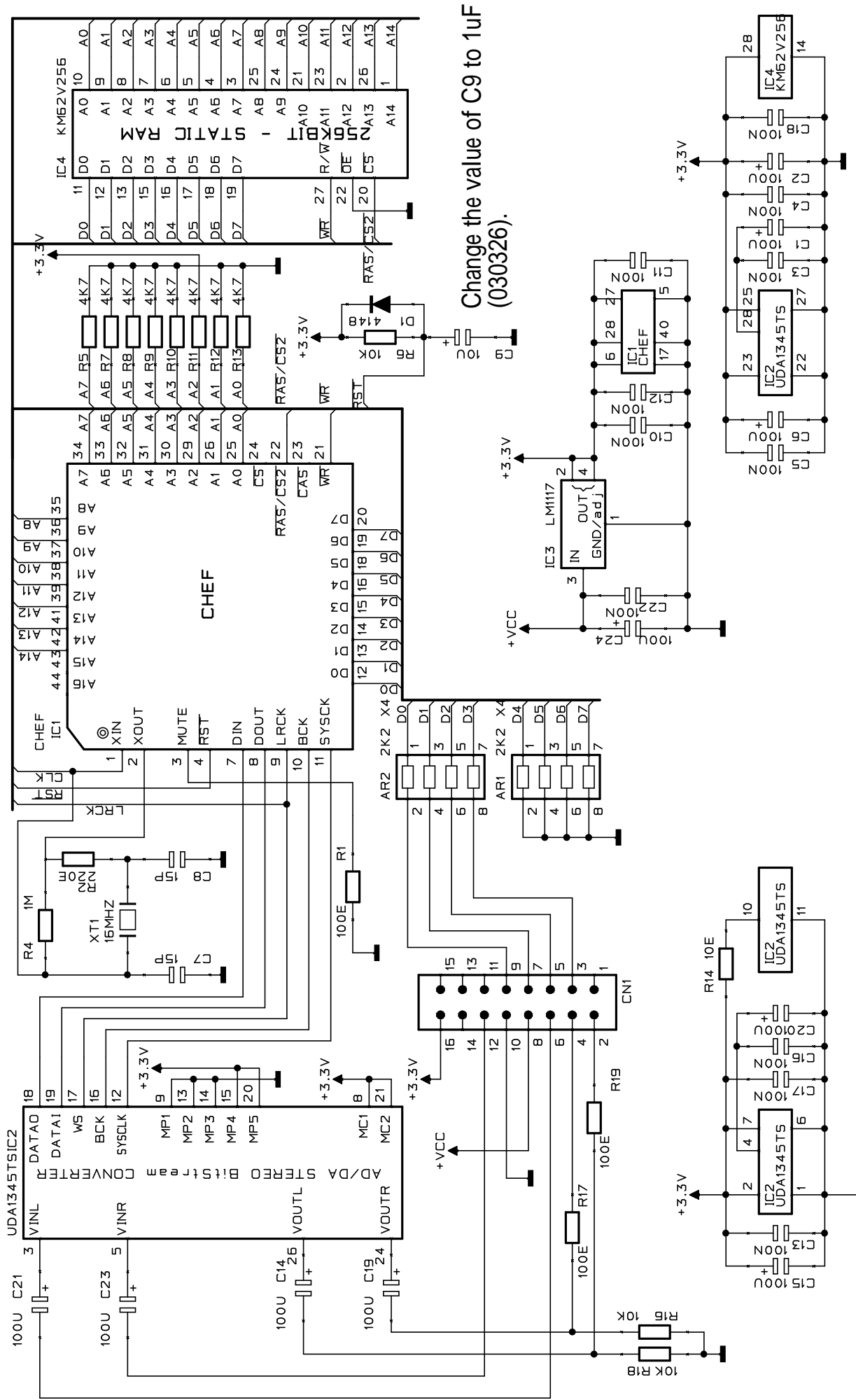

Change the value of C9 to 1uF (030326).

5. Wiring Diagram

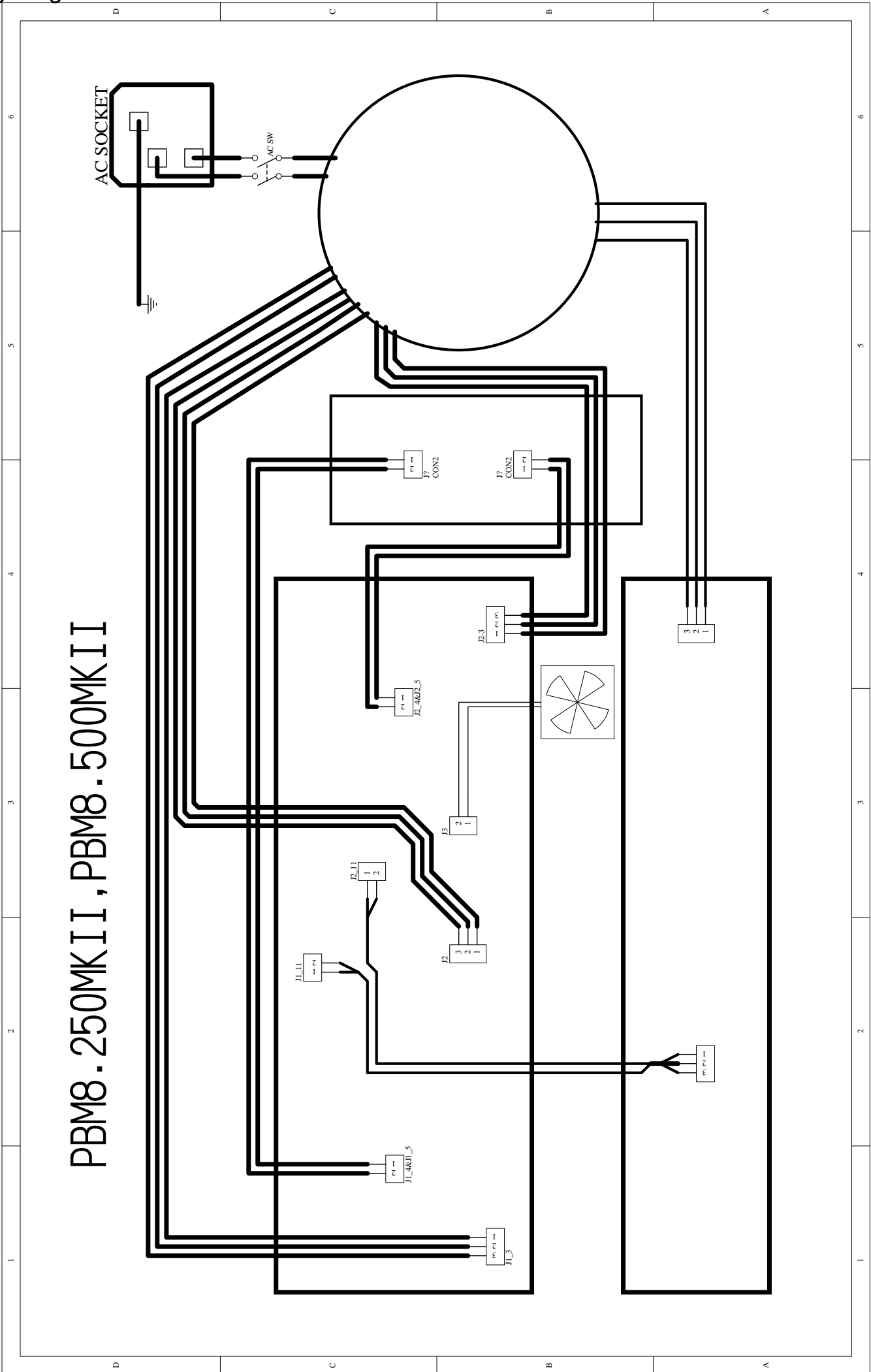

PBM8-250MKII, PBM8-500MKII

7. PBM8.AMP (PBM500, PBM8.250) BIAS Adjustment Procedure

1. Test Instruments

- 1) Digital multi-meter

2. Procedure and Specification

- 1) No signal input to CH1 (J1-11) and CH2 (J2-11): switch on the power supply on the front panel, three green LEDs will light up (D2, D1-16, and D2-16); moreover, D1-4 and D2-4 will light up dimly. Measure R1-11, R2-11(+15V)...R2-12, R1-12(-15V) by using the multi-meter.
- 2) No the signal input, and adjust R1-16(CH1) and R2-16(CH2) to set the values of R1-17/R2-17 as $125 \pm 2 \text{mV}$ (PBM8.250)/ $130 \pm 2 \text{mV}$ (PBM8.500).

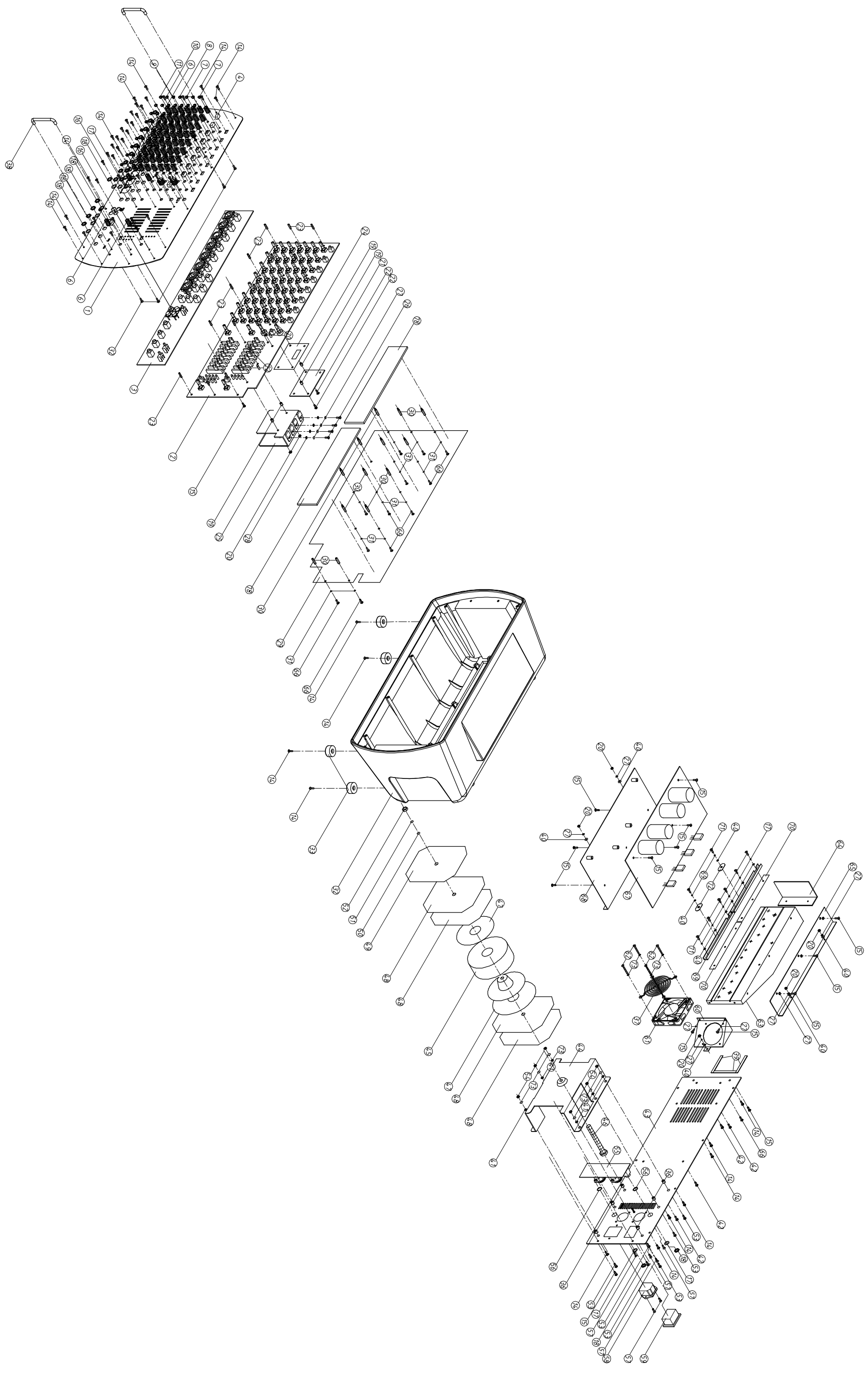

Part List

Mechanical Parts List				
No.	Item NO.	Item Description	Specification	pcs
1	MA05516	front panel	PBM8.250MKII_V1.0	1
2	HK00758	PCB semi-finished product	P-PBM8-CTRL-DIP	1
3	HK00759	PCB semi-finished product	P-PBM8-IN-OUT-DIP	1
4	NI02957	key	9.8*5.5*11.2 black	11
5	NI00359	plastic knob	10*16.5 COOL GRAY 8C	49
6	NI00399	plastic knob	11*19 COOL GRAY 8C	11
7	NI02252	knob nut	7*3.5 072C blue	24
8	NI01147	knob nut	7*3.5 white	8
9	NI02100	knob nut	7*3.5 222C	9
10	NI02692	knob nut	7*3.5 black	8
11	NI02677	knob nut	8.5*4 534C blue	10
12	NI02101	knob nut	8.5*4 222C	1
13	NI02386	plastic knob	outer: 14*13 8C inner:072C	2
14	MG00437	black-plated screw iron-board flat	M3*16	40
15	MG00041	black-plated screw-pill	M3*6	34
16	MG00061	black-plated screw iron-board pill	M3*10	17
17	MF00061	MIC socket washer	circle 1G-02-250	19
18	ME00060	MIC socket nut	hexagon JY-6351G-02-250	19
19	MG00243	copper pillar	M3*5*0.5PH	4
20	ME00015	color nut	3mm	7
21	HK03893	PCB semi-finished product	P-313123-DIP(L-8)	1
22	MG00326	black-plated screw-pill	M3*4	4
23	MG00248	copper pillar	M3*15*0.5PH	15
24	NI02620	insulated board	1*86.5*53 L-8	1
25	MJ02137	heat sink	2t*26*70*73	1
26	MG00166	Ni screw-pill	M3*10	4
27	MF00037	spring washer	3*φ5*1t	13
28	NI02249	cushion (for transistor)	TW-1(TO-220)	4
29	MI02121	insulated board	0.8t*223*420	1
30	MG00363	copper pillar	M3*14*0.5PH	13
31	MF00014	outer gear washer	3*φ6.5*0.5t	13
32	NI03760	rear cover	553.3*275.6*208	2
33	NI02728	rubber foot cushion	29.5*14 black	2

34	MI02203	fixed bracket	11*10*106.2*1.2T	2
35	ND00325	EV foam	5.0T*150*20	2
36	MG00527	copper pillar	M4*8	6
37	MD00444	fan cover- Ni plated	80*80(K-G08a05-4HA)	1
38	MI03003	handle	6*63*18	2
39	ND00388	EV foam black	2.0t*88*6	3
40	MF00030	Ni washer	3* ψ 8*0.8t	11
41	MF00018	color washer	4* ψ 10*1t	6
42	MG00167	Ni screw-flat	M3*10*0.5PH	6
43	MB03525	rear panel	PBM8.500	1
44	MI01876	fixed bracket	PBM-8 1.5t*170*96.5*16.5	1
45	TD00255	loop transformer	PT-PBM8.500_230V	1
46	MG00526	Zn screw –T- square	M8*84*1.25PH	1
47	NI00437	rubber coil	20* ϕ 120*2tB	2
48	MI01630	separating shade	140*140*0.3t	4
49	MJ00326	separating shade	140*140*1.5t	1
50	MF00055	Zn washer	8* ϕ 18*1.5t	1
51	MF00041	spring washer	8* ϕ 13.5*2t	1
52	ME00026	Zn nut	M8	1
53	MG00173	Ni screw- flat	M4*20	6
54	ME00016	color nut	4mm	6

9. Bom

No.	Part No.	Description	Specification	Remark
1	TD00254	transformer	PT-PBM8.250_230V	
2	NI00437	rubber coil	φ20*φ120*2tB	
3	NI01627	fixed bracket	CM-19S	
4	NI00252	sleeve	φ4*20mm	
5	NI00248	sleeve	φ4*1000mm	
6	MA05545	panel	PBM8.250 MK ALTO_V1.1	
7	MA05636	panel	PBM8.250MK	
8	MA05516	panel	1.5t*475.23*257.4_V1.2	
9	MJ00088	single light board	1.5*2135*1220 30.67kg	
10	AE00055	solvent	solvent	
11	MB04375	rear board	PBM8.250 MK ALTO_V1.2	
12	MB04506	rear board	PBM8.250MK 1.5t*460*164	
13	AE00343	.	.	
14	AE00177	paint	4866	
15	MB04354	rear board	PBM8.250 MK 1.5t*460*164_V1.1	
16	MJ00088	single light board	1.5*2135*1220 30.67kg	
17	ME00097	screw pillar	M3*10*0.5PH	
18	MG00127	color screw	M4*8	
19	NI03760	rear cover	553.3*275.6*208 PBM8.250 MK black_V1.0	
20	MI03003	handle	PBM8.250 MK φ6*63*18_V1.0	
21	NB04045	cushion	PBM8.500MK _V1.0	
22	NB04087	gift carton	PBM8.250 MK ALTO_V1.0	
23	NE14892	label	PBM8.250 MK _V1.0	
24	NI00014	membrane	0.035*1M	
25	NH00012	bond paper	0.04*1M	
26	NF02299	user manual	PBM8.250 MK /PBM8.500 MK ALTO_V1.0	
27	NH00149	paper	889*640mm	
28	NI02728	rubber foot	φ29.5*14 black	
29	MF00041	washer	φ8*φ13.5*2t	
30	MF00038	washer	φ4*φ7*1t	
31	MG00041	screw	M3*6	
32	MG00437	screw	M3*16	
33	NI00359	knob	φ10*16.5	
34	NI00399	knob	φ11*19mm	
35	NI00218	cable tie	ALT-102SB	
36	NI02692	knob cover	φ7*3.5 black	
37	NI02957	knob	9.8*5.5*11.2mm black_V1.0	
38	NI02620	insulation board	1*86.5*53 L-8	
39	NC00010	insulation board	0.65M*60M*1t	
40	NI02100	knob cover	φ7*3.5 222C	
41	NI02101	knob cover	φ8.5*4 222C	
42	NI02386	knob	φ14*13mm	

No.	Part No.	Description	Specification	Remark
43	NI02677	knob cover	φ8.5*4 534C blue	
44	NI02252	knob cover	φ7*3.5 072C	
45	NI01147	knob cover	φ7*3.5	
46	NE11347	label	ALTO PI	
47	NH00334	cone paper	0.040*1m	
48	NF00061	assurance card	ALTO	
49	ND00388	EV foam	2.0t*88*6_V1.0	
50	NE00840	label	SOLTON	
51	NH00115	paper	0.045*1M	
52	NI00015	membrane	0.04*1M	
53	NB02912	carton	PBM8.250/PBM8.500 ALTO_V1.1	
54	ND00325	EV foam	5.0t*150*20mm_V1.0	
55	NC00131	washer	1*φ11.3*φ15.3 red	
56	MI02132	fixed bracket	PBM-8 L short type_V1.0	
57	MI02133	fixed bracket	PBM-8 L short type_V1.0	
58	MJ00088	single light board	1.5*2135*1220 30.67kg	
59	MI01876	fixed bracket	PBM-8 1.5t*110*60*120_V1.2	
60	MJ00069	iron board	1.5*2135*1220 30.67kg	
61	MI02121	separating shade	PBM-8_V1.0	
62	MJ00999	AL plate-RS	1*2000*1000 5.44kg	
63	MI02128	fixed bracket	PBM-8 L type_V1.0	
64	MI02129	fixed bracket	PBM-8 L type_V1.0	
65	MJ00058	single light board	1*2135*1220 20.45kg	
66	NA00279	clip-chain bag	0.04t*100*150mm_V1.0	
67	NA00135	PE bag	0.05t*610*500mm	
68	NA00137	clip-chain bag	5*7	
69	MJ00326	barrier	PBM-8_V1.2	
70	MJ00092	AL plate-RS	1.5*2000*1000 8.16kg	
71	MJ00229	barrier	PBM-8_V1.3	
72	MJ00087	iron board	0.3*200*3000 1.431kg	
73	MI02294	fixed bracket	PBM8.500_V1.0	
74	MJ00059	single light board	1.2*2135*1220 24.54kg	
75	MG00042	screw	M3*10	
76	MG00061	screw	M3*10	
77	MG00161	screw	M3*6	
78	MG00173	screw	M4*20	
79	MF00018	washer	φ4*φ10*1t_V1.0	
80	MF00105	washer	φ4*φ10*1t_V1.0	
81	MJ00058	single light board	1*2135*1220 20.45kg	
82	MG00167	screw	M3*10	
83	MF00037	washer	φ3.2*φ5.5*1t	
84	MF00055	washer	φ8*φ18*1.5t	

No.	Part No.	Description	Specification	Remark
85	MF00048	washer	φ4*φ8*0.5t	
86	ME00016	color nut	4m/m	
87	ME00015	color nut	3m/m	
88	MF00061	MIC jack	φ9.6*φ13*0.5t	
89	ME00026	nut	8m/m	
90	MG00111	color screw	pill 4*30	
91	MF00014	washer	φ3*φ6.5*0.5t	
92	ME00060	MIC jack	JY-6351G-02-250	
93	MD00444	protective cover	80*80mm(K-G08A05-4HA)	
94	MG00363	copper pillar	M3*14*0.5PH	
95	MG00248	copper pillar	M3*15*0.5PHdouble plane	
96	MG00243	copper pillar	M3*5*0.5PH	
97	MG00526	screw	M6*75*1.0PH	
98	MG00527	copper pillar	M4*8*0.7PH	
99	HK01409	PC board	P-313123-DIP(AMX-140FX)	
100	SC00004	crystal oscillator	16.00MHZ	XT1
101	HC00484	connector	2.54 180° 2*8P(gold-plated) 13.5/19mm	CN2
102	SG00193	SMD integrated circuit	AT27LV010A-90JC/L-8	IC4
103	SG00139	SMD integrated circuit	AT27LV010A-90JC	
104	HK03894	PC board	P-313123-SMD(L-8)	
105	HB00895	PCB	313123/2(1*6)	
106	CI00049	SMD ceramic capacitor 0603	15PF/50V C0G±5%(C1608C0G1H150JT)/TDK	C8,C9
107	CI00075	SMD ceramic capacitor 0603	0.1uF/50V Y5V +80,-20%	C17,C15,C18,C6,C10,C22,C20,C13,C14,C1,C3,C4,C11
108	RD00061	SMD fixed resistor 1/10W	10Ω ±5% 0603	R22
109	RD00068	SMD fixed resistor 1/10W	100Ω ±5% 0603	R12,R14,R7,R8,R34,R17,R13,R33
110	RD00073	SMD fixed resistor 1/10W	220Ω ±5% 0603	R3
111	RD00085	SMD fixed resistor 1/10W	1.5KΩ ±5% 0603	R16,R15,R21,R20,R4,R19,R10,R18,R9,R5
112	RD00088	SMD fixed resistor 1/10W	2.2KΩ ±5% 0603	R28,R27,R23,R24,R29,R30,R25,R26
113	RD00101	SMD fixed resistor 1/10W	10KΩ ±5% 0603	R32,R31,R1
114	RD00125	SMD fixed resistor 1/10W	1.0MΩ ±5% 0603	R2
115	RE00006	SMD resistor networks	100Ω*4 ±5% 8P 0603	AR1,AR2
116	SE00011	SMD rectifier diode	RLS4148 0.5A (LL-34)	D1
117	SG00068	SMD integrated circuit	74HC14DT(SO-14)/(PHI)	IC1
118	SG00410	SMD integrated circuit	IC41LV16256-35KG(SOJ40)/(ICSI)	IC6
119	SG00166	SMD integrated circuit	TY-2 ALTO(GMCODE:105022)	IC3
120	SG00147	SMD integrated circuit	CHEF DSP(GMCODE:105022)	
121	SG00037	SMD integrated circuit	LD1117DT33C(TO-252)	IC2
122	HC00611	IC socket (SMD)	PLCC32 (AMP S/N:822498)	IC4
123	SG00016	SMD integrated circuit	UDA1345TS (Philips)	IC5
124	AE00221	tin soldering paste	SJ-617	
125	NE11475	label	L-8	

No.	Part No.	Description	Specification	Remark
126	NH00221	paper	0.055*1M	
127	NI00016	membrane	0.05*1M	
128	AC00002	solder wire	63/37%	
129	CB00166	electrolytic capacitor	100uF/16V φ6*5mm	C19,C12,C5,C2,C24,C16,C21
130	HK00758	PC board	P-PBM8_CTRL-DIP	
131	CB00009	electrolytic capacitor	1uF/50V φ4*7mm	C1
132	CB00199	electrolytic capacitor	10uF/25V φ4*7mm	C4,C8,C1-7,C2-7,C34,C35,C36,C3-7,C37,C38,C4-7,C55,C5-7,C57,C6-7,C7-7,C8-7,C1-10,C2-10,C3-10,C4-10,C5-10,C6-10,C7-10,C7-17,C7-20,C8-10,C8-17,C8-20
133	CB00039	electrolytic capacitor	47uF/25V φ5*11mm	C13,C15,C19
134	CB00139	electrolytic capacitor	4.7uF/63V NP φ6.3*11mm	C39
135	CF00032	metal-film capacitor MSC	0.1uF/100V 5% CASE01	C53,C40
136	CB00073	electrolytic capacitor	1000uF/35V φ13*20mm	C41,C42
137	CB00186	electrolytic capacitor	33uF/100V φ8*11.5mm	C44,C43
138	CB00058	electrolytic capacitor	220uF/35V φ10*12mm	C47
139	CB00187	electrolytic capacitor	100uF/100V φ10*20mm	C48,C49
140	CB00137	electrolytic capacitor	2.2uF/100V φ5*11mm	C51
141	CB00127	electrolytic capacitor	47uF/63V φ6*11mm	C52
142	SA00053	L.E.D	φ3 round(red)long foot 26mm	D1,D6,D11,D16
143	SA00093	rectifier diode	1N4148 0.5A	D2,D7,D12,D22
144	SA00052	L.E.D	φ3 round(green)long foot 26	D3,D4,D8,D9,D13,D14,D21
145	SA00054	L.E.D	3m/m round(yellow)long foot 26	D5,D10,D15
146	NI01786	LED spacer support	LEDS-12 12mm	
147	SA00167	bridge rectifier	2A W2-04	D18,D17
148	SA00098	rectifier diode	1A/400V IN4004	D19,D20
149	HC00644	connector(male)	3P 3.96mm 90°	J2
150	HC00473	connector	2.45mm 180° 2*8P B25-2*8BG1(B)H=5mm	J1
151	HA02076	header wiring	14P-14P 30mm PH=1.27mm	J4,J3
152	RC00365	slide potentiometer	W100KΩ RA3072-20R-9.5LC-W100K-C04	RF1-7,RF2-7,RF3-7,RF4-7,RF5-7,R F6-7,RF7-7,RF8-7,RF9-7,RF10-7,R F11-7,RF12-7,RF13-7,RF14-7,RF1 5-7,RF16-7,RF17-7,RF18-7
153	RA00231	fixed resistor 1/4W	4.7KΩ M type	R1
154	RC00358	potentiometer	B50KΩ-RD09F113A223-50K2BT(SAS1);30F-C	R1-1,R1-2,R1-3,R1-4,R1-5,R1-6,R1-7,R20,R 2-1,R2-2,R2-3,R2-4,R2-5,R2-6,R2-7,R27,R3- 1,R3-2,R3-3,R3-4,R3-5,R3-6,R3-7,R4-1,R4-2 ,R4-3,R4-4,R4-5,R4-6,R4-7,R5-1,R5-2,R5-3, R5-4,R5-5,R5-6,R5-7,R6-1,R6-2,R6-3,R6-4, R6-5,R6-6,R6-7
155	RC00360	potentiometer	B50KΩ RD12L12CA23A-50K3BT*2(SAS1);30F-C	R13,R38,R7-1,R7-2,R7-3,R7-4,R7-5,R7-6,R 7-7,R8-1,R8-2,R8-3,R8-4,R8-5,R8-6,R8-7
156	RA00119	fixed resistor 1/2W	220Ω M type	R35,R42
157	RA00324	fixed resistor 1/8W	22Ω M type	R92,R93
158	RA00955	metal-oxide-film resistor 5W	82Ω P type	R108
159	RA00139	fixed resistor 1/2W	3.9KΩ M type	R111
160	HI00317	rotary switch	RE2001-40E2-155F-4B	SW1,SW2

No.	Part No.	Description	Specification	Remark
161	HI00238	push-button switch-RS	2 stage 6P PS-9226A(NON-LOCK)	S1
162	HI00236	push-button switch-RS	2-stage 6P PS-9226A(SELF-LOCK)	S2,S3,S1-1,S2-1,S3-1,S4-1,S5-1,S6-1,S7-1,S8-1
163	SD00032	integrated circuit	LM317T	U8,U12,U19
164	SD00033	integrated circuit	LM337SP(1.5A)(TO-220)	U18
165	NI00863	plastic washer	TO220B	
166	ME00015	color nut	3m/m	
167	MF00037	washer	φ3.2*φ5.5*1t	
168	MG00166	screw	M3*10	
169	MG00243	copper pillar	M3*5*0.5PH	
170	MG00326	screw	3*4	
171	MI02137	heat sink	PBM-8_V1.0	
172	MJ00055	AL plate	2*2000*1000 10.88kg	
173	HK00756	PC board	P-PBM8_CTRL-SMD	
174	HB01097	PCB	PBM8-CTRL_VER051124.	
175	CI00146	SMD ceramic capacitor 0805	0.22uF/50V X7R ±10%	CF1-1,CF1-2,CF2-1,CF2-2,CF10-1,CF10-2,CF10-3,CF10-4,CF11-1,CF11-2,CF11-3,CF11-4
176	CI00098	SMD ceramic capacitor 0805	0.033uF/50V X7R ±10%	CF3-1,CF3-2,CF4-1,CF4-2,CF12-1,CF12-2,CF12-3,CF12-4,CF13-1,CF13-2,CF13-3,CF13-4
177	CI00112	SMD ceramic capacitor 0805	0.01uF/50V X7R ±10%	CF5-1,CF5-2,CF6-1,CF6-2,CF14-1,CF14-2,CF14-3,CF14-4,CF15-1,CF15-2,CF15-3,CF15-4
178	CI00021	SMD ceramic capacitor 0805	0.001uF/50V NPO ±5%	C1-3,C2-3,C3-3,C4-3,C5-3,C6-3,CF7-1,CF7-2,CF7-3,CF8-1,CF8-2,CF8-3,CF9-1,CF9-2,CF16-1,CF16-2,CF16-3,CF16-4,CF17-1,CF17-2,CF17-3,CF17-4,CF18-1,CF18-2,CF18-3,CF18-4,C7-13,C8-13
179	CI00007	SMD ceramic capacitor 0805	22PF/50V NPO	C2,C3,C5,C6,C7,C9,C11,C12,C14,C16,C18,C20,C22,C24,C26,C30,C7-1,C8-1,C7-11,C8-11
180	CI00013	SMD ceramic capacitor 0805	56PF/50V NPO	C1-1,C2-1,C3-1,C4-1,C5-1,C6-1
181	CI00024	SMD ceramic capacitor 0805	0.0022uF/50V X7R ±10%	C1-2,C2-2,C3-2,C4-2,C5-2,C6-2,C7-2,C8-2,C7-12,C8-12
182	CI00016	SMD ceramic capacitor 0805	100PF/50V NPO	C1-4,C2-4,C3-4,C4-4,C5-4,C6-4,C7-4,C8-4,C7-14,C8-14
183	CI00026	SMD ceramic capacitor 0805	0.0033uF/50V X7R ±10%	C1-5,C2-5,C3-5,C4-5,C5-5,C6-5,C7-5,C8-5,C7-15,C8-15
184	CI00133	SMD ceramic capacitor 0805	0.047uF/-50V X7R ±10 %	C1-6,C2-6,C3-6,C4-6,C5-6,C6-6,C7-6,C8-6,C7-16,C8-16
185	CI00001	SMD ceramic capacitor 0805	10PF/50V NPO	C1-8,C1-9,C23,C25,C27,C2-8,C2-9,C2-9,C31,C33,C3-8,C3-9,C4-8,C4-9,C5-8,C5-9,C6-8,C6-9,C7-8,C7-9,C8-8,C8-9,C7-18,C7-19,C8-18,C8-19
186	CI00018	SMD ceramic capacitor 0805	220PF/50V NPO ±5%	C28,C32
187	CI00100	SMD ceramic capacitor 0805	0.1uF/50V X7R ±10%	C45,C46,C54,C58,C60,C61,C62,C63,C64,C65,C66,C67,C68,C1-11,C1-12,C1-13,C1-14,C2-11,C2-12,C2-13,C2-14,C3-11,C3-12,C3-13,C3-14,C4-11,C4-12,C4-13,C4-14,C5-11,C5-12,C5-13,C5-14,C6-11,C6-12,C6-13,C6-14,C7-21,C7-22,C7-23,C7-24,C8-21,C8-22,C8-23,C8-24,C69,C50,C56

No.	Part No.	Description	Specification	Remark
188	RD00038	SMD fixed resistor 1/8W	22KΩ ±5% 0805	RF1-1,RF1-3,RF1-4,RF2-1,RF2-3,RF2-4,R50,R53,R58,R61,R66,R69,R73,R78,R85,RF10-1,RF10-3,RF10-4,RF10-8,RF11-1,RF11-3,RF11-4,RF11-8,R1-20,R1-23,R1-25,R1-26,R1-28,R2-20,R2-23,R2-25,R2-26,R2-28,R3-20,R3-23,R3-25,R3-26,R3-28,R4-20,R4-23,R4-25,R4-26,R4-28,R5-20,R5-23,R5-25,R5-26,R5-28,R6-20,R6-23,R6-25,R6-26,R6-28,R7-20,R7-23,R7-26,R7-27,R7-28,R7-43,R7-46,R7-49,R8-20,R8-23,R8-26,R8-27,R8-28,R8-43,R8-46,R8-49,RF10-10,RF10-11,RF11-10,RF11-11
189	RD00028	SMD fixed resistor 1/8W	5.6KΩ ±5% 0805	RF1-2,R33,R49,R54,R57,R62,R65,R70,RF7-2,RF10-2,RF10-9,R1-21,RF16-2,RF16-9,R2-21,R3-21,R4-21,R5-21,R6-21,R7-21,R7-44,R8-21,R8-44
190	RD00036	SMD fixed resistor 1/8W	18KΩ ±5% 0805	RF1-5,RF2-5,RF3-5,RF4-5,RF5-5,RF6-1,RF6-3,RF6-4,RF6-5,RF7-5,RF8-5,RF9-5,RF10-5,RF11-5,RF12-5,RF13-5,RF14-5,RF15-1,RF15-3,RF15-4,RF15-5,RF15-8,RF16-5,RF17-5,RF18-5,RF10-12,RF11-12,RF12-12,RF13-12,RF14-12,RF15-10,RF15-11,RF15-12,RF16-12,RF17-12,RF18-12
191	RD00019	SMD fixed resistor 1/8W	1.2KΩ ±5% 0805	RF2-2,RF11-2,RF11-9
192	RD00046	SMD fixed resistor 1/8W	56KΩ ±5% 0805	R14,R16,R21,RF3-1,RF3-3,RF3-4,RF8-1,RF8-3,RF8-4,RF12-1,RF12-3,RF12-4,RF12-8,RF17-1,RF17-3,RF17-4,RF17-8,RF12-10,RF12-11,RF17-10,RF17-11,R34
193	RD00025	SMD fixed resistor 1/8W	3.3KΩ ±5% 0805	RF3-2,RF8-2,RF12-2,RF12-9,RF17-2,RF17-9
194	RD00040	SMD fixed resistor 1/8W	27KΩ ±5% 0805	RF4-1,RF4-3,RF4-4,RF9-1,RF9-3,RF9-4,RF13-1,RF13-3,RF13-4,RF13-8,RF18-1,RF18-3,RF18-4,RF18-8,RF13-10,RF13-11,RF18-10,RF18-11
195	RD00021	SMD fixed resistor 1/8W	1.8KΩ ±5% 0805	RF4-2,RF13-2,RF13-9
196	RD00044	SMD fixed resistor 1/8W	47KΩ ±5% 0805	RF5-1,RF5-3,RF5-4,RF14-1,RF14-3,RF14-4,RF14-8,RF14-10,RF14-11
197	RD00454	SMD fixed resistor 1/8W	2.7KΩ ±5% 0805	R29,R40,R46,RF5-2,R103,R106,RF14-2,RF14-9
198	RD00018	SMD fixed resistor 1/8W	1.0KΩ ±5% 0805	R19,RF6-2,R76,R77,R81,R82,R88,R89,R96,R1-22,RF15-2,RF15-9,R2-22,R3-22,R4-22,R5-22,R6-22,R7-22,R7-45,R8-22,R8-45
199	RD00049	SMD fixed resistor 1/8W	100KΩ ±5% 0805	RF7-1,RF7-3,RF7-4,R74,R79,R86,RF16-1,RF16-3,RF16-4,RF16-8,RF16-10,RF16-11
200	RD00023	SMD fixed resistor 1/8W	2.2KΩ ±5% 0805	RF9-2,R1-13,R1-15,RF18-2,RF18-9,R2-13,R2-15,R3-13,R3-15,R4-13,R4-15,R5-13,R5-15,R6-13,R6-15,R7-13,R7-15,R7-36,R7-38,R8-13,R8-15,R8-36,R8-38
201	RD00016	SMD fixed resistor 1/8W	680Ω ±5% 0805	R2,R3,R4,R5,R6,R7,R8,R9,R37,R44,R83,R90,R94
202	RD00015	SMD fixed resistor 1/8W	560Ω ±5% 0805	R1-8,R2-8,R3-8,R4-8,R5-8,R6-8
203	RD00479	SMD fixed resistor 1/8W	180Ω ±5% 0805	R1-9,R2-9,R3-9,R4-9,R5-9,R6-9,R84,R91,R95

No.	Part No.	Description	Specification	Remark
204	RD00032	SMD fixed resistor 1/8W	10K Ω \pm 5% 0805	R10,R11,R12,R18,R24,R99,R1-14, R1-16,R1-18,R1-19,R1-27,R2-14,R 2-16,R2-18,R2-19,R2-27,R3-14,R3- 16,R3-18,R3-19,R3-27,R4-14,R4-1 6,R4-18,R4-19,R4-27,R5-14,R5-16, R5-18,R5-19,R5-27,R6-14,R6-16,R 6-18,R6-19,R6-27,R7-14,R7-16,R7- 18,R7-37,R7-39,R7-41,R8-14,R8-1 6,R8-18,R8-37,R8-39,R8-41,R97,R 98
205	RD00033	SMD fixed resistor 1/8W	12K Ω \pm 5% 0805	R15,R17,R22
206	RD00009	SMD fixed resistor 1/8W	220 Ω \pm 5% 0805	R23,R48,R101,R104,R107,R110
207	RD00480	SMD fixed resistor 1/8W	68K Ω \pm 5% 0805	R25,R7-10,R7-33,R8-10,R8-33
208	RD00481	SMD fixed resistor 1/8W	8.2K Ω \pm 5% 0805	R28,R39,R45,R7-9,R8-9,R10 0,R7-32,R8-32
209	RD00042	SMD fixed resistor 1/8W	33K Ω \pm 5% 0805	R32,R36,R43
210	RD00043	SMD fixed resistor 1/8W	39K Ω \pm 5% 0805	R52,R56,R60,R64,R68,R72
211	RD00056	SMD fixed resistor 1/8W	1.0M Ω \pm 5% 0805	R75,R80,R87
212	RD00030	SMD fixed resistor 1/8W	6.8K Ω \pm 5% 0805	R1-10,R2-10,R3-10,R4-10,R5-10,R 6-10,R51,R55,R59,R63,R67,R71
213	RD00020	SMD fixed resistor 1/8W	1.5K Ω \pm 5% 0805	R1-12,R2-12,R3-12,R4-12,R5-12,R 6-12,R7-35,R8-35,R7-12,R8-12
214	RD00050	SMD fixed resistor 1/8W	150K Ω \pm 5% 0805	R1-17,R2-17,R3-17,R4-17,R5-17,R 6-17,R7-17,R7-40,R8-17,R8-40
215	RD00027	SMD fixed resistor 1/8W	4.7K Ω \pm 5% 0805	R1-24,R2-24,R3-24,R4-24,R5-24,R 6-24,R7-24,R7-47,R8-47,R8-24
216	RD00051	SMD fixed resistor 1/8W	180K Ω \pm 5% 0805	R102
217	SG00122	SMD integrated circuit	NJM4580M-TE3	UF1,U1,UF2,U2,UF3,U3,UF4,U4,U F5,U5,UF6,U6,UF7,U7,UF8,UF9,U9 ,UF10,U10,UF11,U1-1,U11,UF12,U 1-2,UF13,U13,UF14,U14,U15,U16, U17,U2-1,U2-2,U3-1,U3-2,U4-1,U4- 2,U5-1,U5-2,U6-1,U6-2,U7-1,U7-2, U7-3,U8-1,U8-2,U8-3
218	RD00037	SMD fixed resistor 1/8W	20K Ω \pm 5% 0805	R41,R47,R30
219	RD00017	SMD fixed resistor 1/8W	820 Ω \pm 5% 0805	R109
220	RD00052	SMD fixed resistor 1/8W	220K Ω \pm 5% 0805	R112
221	SE00011	SMD rectifier diode	RLS4148 0.5A (LL-34)	D23,D24,D25,D27
222	SF00051	transistor	SST176(S6)(SOT-23)/(VISHAY)	TR1,TR2
223	AE00221	tin soldering paste	SJ-617	
224	HK00669	PC board	P-DIGIT_EFFECTD_REV04-DIP(RX700)	P1
225	HC00618	connector	2.54 90° 12P 4.0/13.31mm	P1
226	HK00668	PC board	P-DIGIT_EFFECTD_REV04-SMD	
227	HB01092	PCB	DIGIT_EFFECT_REV04	
228	CI00026	SMD ceramic capacitor 0805	0.0033uF/50V X7R \pm 10%	C1,C6
229	CJ00005	SMD AL electrolytic capacitor	10uF/16V CASE4 ϕ	C2,C5,C9
230	CI00013	SMD ceramic capacitor 0805	56PF/50V NPO	C3,C10
231	CI00100	SMD ceramic capacitor 0805	0.1uF/50V X7R \pm 10%	C4,C7,C8,C12,C17,C18,C19
232	CI00146	SMD ceramic capacitor 0805	0.22uF/50V X7R \pm 10%	C11

No.	Part No.	Description	Specification	Remark
233	CI00007	SMD ceramic capacitor 0805	22PF/50V NPO	C15,C13
234	CI00145	SMD ceramic capacitor 0805	0.0015uF/50V X7R ±10%	C14
237	SE00011	SMD rectifier diode	RLS4148 0.5A (LL-34)	D2,D3,D4,D5,D6,D7
238	SF00051	transistor	SST176(S6)(SOT-23)/(VISHAY)	Q1,Q2
239	RD00003	SMD fixed resistor 1/8W	10Ω ±5% 0805	R1,R9,R10,R11
240	RD00032	SMD fixed resistor 1/8W	10KΩ ±5% 0805	R2,R3,R12,R13,R19,R20,R22,R25,R29
241	RD00042	SMD fixed resistor 1/8W	33KΩ ±5% 0805	R4,R14
242	RD00018	SMD fixed resistor 1/8W	1.0KΩ ±5% 0805	R5
243	RD00030	SMD fixed resistor 1/8W	6.8KΩ ±5% 0805	R6,R16,R27
244	RD00034	SMD fixed resistor 1/8W	15KΩ ±5% 0805	R7,R17
245	RD00056	SMD fixed resistor 1/8W	1.0MΩ ±5% 0805	R15,R26,R34
246	RD00023	SMD fixed resistor 1/8W	2.2KΩ ±5% 0805	R21,R31,R32
247	RD00049	SMD fixed resistor 1/8W	100KΩ ±5% 0805	R23
248	RD00267	SMD fixed resistor 1/8W	820KΩ ±5% 0805	R24
249	RD00057	SMD fixed resistor 1/8W	2.2MΩ ±5% 0805	R28
250	RD00009	SMD fixed resistor 1/8W	220Ω ±5% 0805	R30
251	RD00038	SMD fixed resistor 1/8W	22KΩ ±5% 0805	R33
252	SG00200	SMD integrated circuit	NJM4580V-TE1/(JRC)	U1,U2
253	SG00306	SMD integrated circuit	LM393DR(TI)/(MEXICO)	U3
254	SG00094	SMD integrated circuit	NE555DT/(ST)	U4
255	SG00068	SMD integrated circuit	74HC14DT(SO-14)/(PHI)	U5
256	SG00164	SMD integrated circuit	74HC109D	U6
257	AE00221	tin soldering paste	SJ-617	
258	AC00002	solder wire	63/37%	
259	RA00157	fixed resistor 1/4W	0.0Ω	R31
260	CB00050	electrolytic capacitor	100uF/50V φ8*11mm	C71
261	CB00069	electrolytic capacitor	1000uF/6.3V φ8*11mm	C70
262	CB00064	electrolytic capacitor	470uF/16V φ10*12mm	C59
263	NC00005	silicone insulator	TO-220 square type	
264	AC00002	solder wire	63/37%	
265	RA00957	fixed resistor 1/8W	100Ω	RF1-6,RF2-6,RF3-6,RF4-6,RF5-6,RF6-6,RF7-6,RF8-6,RF9-6,RF10-6,RF11-6,RF12-6,RF13-6,RF14-6,RF15-6,RF16-6,RF17-6,RF18-6,RF10-13,RF11-13,RF12-13,RF13-13,RF14-13,RF15-13,RF16-13,RF17-13,RF18-13
266	HK00759	PC board	P-PBM8-IN_OUT-DIP	
267	CB00199	electrolytic capacitor	10uF/25V φ4*7mm	C1,C2,C7,C8,C1-3,C1-4,C1-7,C17,C18,C20,C2-3,C2-4,C26,C2-7,C27,C3-3,C3-4,C4-3,C4-4,C5-3,C5-4,C6-3,C6-4,C7-5,C7-6,C7-8,C8-5,C8-6,C8-8
268	CB00033	electrolytic capacitor	22uF/25V φ6*7mm	C5,C6
269	CB00203	electrolytic capacitor	47uF/35V φ5*11mm	C11,C12,C15,C16,C22,C24
270	CB00127	electrolytic capacitor	47uF/63V φ6*11mm	C1-1,C1-2,C2-1,C2-2,C3-1,C3-2,C4-1,C4-2,C5-1,C5-2,C6-1,C6-2,C7-1,C7-2,C8-1,C8-2
271	HC00371	MIC jack	SCJ-0658-1-Y	J1,J2,J3,J5,J6,J7,J8,J1-2,J2-2,J3-2,J4-2,J5-2,J6-2,J7-2,J7-3,J8-2,J8-3
272	HC00403	RCA jack	SCP6873NS3232T2 4P	J4
273	HC00077	connector(male)	3P 2.5mm 180°	J9
274	HC00126	balance MIC jack-RS	JY-5042-030G female plug 180°	J1-1,J2-1,J3-1,J4-1,J5-1,J6-1,J7-1,J8-1

No.	Part No.	Description	Specification	Remark
275	HC00076	connector(male)	2P 2.5mm 180°	J1-3,J2-3
276	HC00365	connector(male)	14P 2.54mm 180°(C03-14AG1)	J10,J11
277	RA00184	fixed resistor 1/4W	100Ω M type	R19,R22,R29,R32,R42,R47
278	RA00103	fixed resistor 1/2W	22Ω M type	R48,R49
279	HI00246	slide switch	2 stages 6P SS-22H23-G14(2P2T)	S2,S3
280	HI00247	slide switch	3 stages 8P SS-23D14-G14(2P3T)	S4
281	HA01918	jump	4mm	S1-1,S2-1
282	HK00760	PC board	P-PBM8-IN_OUT-SMD	
283	HB01098	PCB	PBM8-IN_OUT_REV05	
284	CI00007	SMD ceramic capacitor 0805	22PF/50V NPO	C3,C4,C9,C10,C13,C14
285	CI00013	SMD ceramic capacitor 0805	56PF/50V NPO	C1-5,C1-6,C19,C21,C2-5,C2-6,C3-5,C3-6,C4-5,C4-6,C5-5,C5-6,C6-5,C6-6,C7-3,C7-4,C8-3,C8-4
286	CI00100	SMD ceramic capacitor 0805	0.1uF/50V X7R ±10%	C1-8,C1-9,C23,C25,C28,C29,C3-7,C3-8,C5-7,C5-8,C7-9,C7-10
287	RD00009	SMD fixed resistor 1/8W	220Ω ±5% 0805	R1
288	RD00040	SMD fixed resistor 1/8W	27KΩ ±5% 0805	R2,R3
289	RD00032	SMD fixed resistor 1/8W	10KΩ ±5% 0805	R4,R5,R6,R7,R8,R9,R10,R11,R1-2,R13,R16,R18,R20,R21,R2-2,R23,R24,R27,R28,R30,R31,R3-2,R33,R34,R35,R39,R41,R4-2,R43,R44,R46,R5-2,R6-2,R7-3,R8-3,R1-10,R1-11,R2-10,R2-11,R3-10,R3-11,R4-10,R4-11,R5-10,R5-11,R6-10,R6-11
290	RD00030	SMD fixed resistor 1/8W	6.8KΩ ±5% 0805	R1-1,R1-3,R17,R2-1,R2-3,R26,R3-1,R3-3,R4-1,R4-3,R5-1,R5-3,R6-1,R6-3,R7-1,R7-2,R8-1,R8-2
291	RD00023	SMD fixed resistor 1/8W	2.2KΩ ±5% 0805	R1-4,R1-5,R1-8,R1-9,R2-4,R2-5,R2-8,R2-9,R3-4,R3-5,R36,R37,R3-8,R3-9,R4-4,R4-5,R4-8,R4-9,R5-4,R5-5,R5-8,R5-9,R6-4,R6-5,R6-8,R6-9,R1-12,R2-12,R1-13
292	RD00038	SMD fixed resistor 1/8W	22KΩ ±5% 0805	R1-6,R1-7,R2-6,R2-7,R3-6,R3-7,R4-6,R4-7,R5-6,R5-7,R6-6,R6-7,R2-13
293	RD00050	SMD fixed resistor 1/8W	150KΩ ±5% 0805	R12,R14
294	RD00028	SMD fixed resistor 1/8W	5.6KΩ ±5% 0805	R15,R25,R38,R40,R45
295	RD00018	SMD fixed resistor 1/8W	1.0KΩ ±5% 0805	R7-4,R7-5,R8-4,R8-5,R1-14,R2-14,R3-14,R4-12,R5-12,R6-12
296	RD00033	SMD fixed resistor 1/8W	12KΩ ±5% 0805	R7-6,R7-7,R8-6,R8-7
297	RD00036	SMD fixed resistor 1/8W	18KΩ ±5% 0805	R7-8,R8-8,R7-10,R8-10
298	SG00122	SMD integrated circuit	NJM4580M-TE3	U1,U2,U3,U4,U5,U6,U7,U8
299	AE00221	tin soldering paste	SJ-617	
300	CB00040	electrolytic capacitor	47uF/25V φ5*11mm	C1-10,C2-10,C3-10,C4-10,C5-10,C6-10
301	RA00125	fixed resistor 1/2W	470Ω M type	R50
302	CB00217	electrolytic capacitor	470uF/50V φ10*20mm	C30
303	AC00002	solder wire	63/37%	
304	HK04256	PC board	P-PBM8_SPEAKER	
305	HB01216	PCB	PBM8_SPEAK_VER040306	
306	HC00442	speaker socket	NL4MP (NEUTRIK)	
307	HC00371	MIC jack	SCJ-0658-1-Y	
308	MJ00942	fixed bracket	CS12/600	
309	MJ00061	iron board	1*2135*1220 20.45kg	
310	HA01209	single terminal wiring	450 black 450 red (PC250C)	

No.	Part No.	Description	Specification	Remark
311	AC00002	solder wire	63/37%	
312	HJ00006	dessicant	30g	
313	HI00022	power switch-RS	4p black frame red key	
314	HE00049	fan	24V/0.21A 80*80*25mm 360mm JST2P	
315	HD00071	ceramic tube fuse	3.15A 250V ϕ 5.2*20mm CSA/S/T/UL/VDE	
316	HC00008	AC socket	3515 A TYPE(RF-2004-C-4.8)	
317	HA00861	power cord Europe 3P	LT-312+LT-501	
318	HA02276	wire	90mm	
319	HA02774	wire	3P-2P/2P 500mm UL1185 26AWG blue/red	
320	HA02278	wire	90mm	
321	HA01825	wire	100 red	
322	HA01828	P.V.C single wave wired UL1015	230 green	
323	HA01315	single terminal wiring	100 green/yellow	
324	AD00012	twin adhesive	90*120mm_V1.0	
325	HK05800	PC board	P-PBM8AMP(PBM8.250 MKII)	
326	RC00319	semi-fixed resistor	B100 Ω PT1030-V1B101-C1-H10	R1-16,R2-16
327	RA00722	metal-oxide-film resistor 3W	500 Ω P type	R1-21,R2-21
328	RA01106	metal-oxide-film resistor 3W	10 Ω RSS P type	R1-22,R2-22
329	RA00851	metal-oxide-film resistor 2W	22 Ω RSS M type	R1-13,R1-14,R2-13,R2-14
330	RA00138	fixed resistor 1/2W	3.3K Ω M type	R1-33,R2-33
331	RA00051	metal-oxide-film resistor 2W	5.6 Ω P type	R1-26,R2-26
332	RA00071	metal-oxide-film resistor 3W	0.1 Ω RSS P type	R1-23,R1-24,R2-23,R2-24
333	RA00063	metal-oxide-film resistor 3W	1.5K Ω RSS P type	R1-11,R1-12,R2-11,R2-12
334	SB00130	transistor	MPSA42/(PHILIPS)	Q1-6,Q2-6
335	SB00129	transistor	MPSA92(TO92)/(PHI)	Q1-5,Q2-5
336	SB00021	power transistor	2SC5200	Q1-8,Q2-8
337	SB00023	power transistor	2SA1943-O	Q1-7,Q2-7
338	SD00032	integrated circuit	LM317T	U1
339	SD00173	integrated circuit	NJM4580L(JRC)	U2,U1-1,U2-1
340	SA00167	bridge rectifier	2A W2-04	D1,D1-9,D2-9,D1-20,D2-20
341	SB00042	transistor	MJE15032	Q1-1,Q2-1
342	SB00044	transistor	MJE15033	Q1-2,Q2-2
343	RH00018	thermistor	100 Ω (PDBS8101MS)	R1-39,R2-39
344	RH00021	thermistor	500 Ω (TDC5C150L)	R3
345	RH00017	thermistor	50 Ω (TDC05A050J)	R1-8,R2-8
346	SA00007	bridge rectifier	8A KBU-806 comb type	D1-1,D2-1
347	SA00002	high speed diode	1A/600V 1N4937	D1-11,D1-12,D2-11,D2-12
348	SA00054	L.E.D	3m/m round(yellow)long foot 26	D1-21,D2-21
349	SA00026	L.E.D	ϕ 5 circle red B1115	D1-4,D2-4
350	SA00052	L.E.D	ϕ 3 round(green)long foot 26	D2,D1-16,D2-16
351	SA00053	L.E.D	ϕ 3 round(red)long foot 26mm	D1-18,D2-18
352	NI02384	LED spacer support	LEDS-4 4mm	
353	NC00182	insulator	MISTRAL900 1.6t*130*16mm	
354	NC00041	insulation board	1.6t*0.65M*70M	
355	NC00005	silicone insulator	TO-220 square type	
356	MI02134	fixed bracket	PBM-8 L long type_V1.0	
357	MI02135	fixed bracket	PBM-8 I long type_V1.0	

No.	Part No.	Description	Specification	Remark
404	SA00257	Zener diode	1/2W 3.9V	D1-13,D1-14,D2-13,D2-14
405	RA01113	fixed resistor 1/4W	10KΩ	R1-2,R1-3,R2-2,R2-3,R1-28,R2-28
406	RA01328	fixed resistor 1/8W	12KΩ	R1-6,R2-6,R1-37,R1-38,R2-38
407	HB01263	PCB	PBM8AMP_VER050825	
408	HC00064	FUSE holder	JEF-503B (5.2mm)	F1-1,F1-01,F1-2,F1-02,F2-1,F2-01, F2-2,F2-02
409	HC00365	connector(male)	14P 2.54mm 180°(C03-14AG1)	J4
410	HC00172	connector(male)	3P 3.96mm 180°	J2,J1-9,J2-9
411	HC00076	connector(male)	2P 2.5mm 180°	J1-11,J2-11,J3
412	HD00079	ceramic tube fuse	4A250V φ5.2*20mm CSA/S/T/UL/VDE	
413	HC00504	connector(male)	10P 2.54mm 180°	J1
414	HC00324	connect terminal	6.5m/m (PC250)	J1-4,J1-5,J2-4,J2-5
415	HC00034	short circuit connector	NO.2700 2.54mm/6mm OPEN	
416	CF00033	metal-film capacitor MEF	0.1uF/250V	C1-2,C2-2
417	CB00009	electrolytic capacitor	1uF/50V φ4*7mm	
418	CN00060	fixed inductance	2uH 10A(CSAF-302824)(φ1.5mm*12 1/2T)	L1-1,L2-1
419	CB00208	electrolytic capacitor	4700uF/100V φ30*50mm	C1-15,C1-16,C2-15,C2-16
420	CB00217	electrolytic capacitor	470uF/50V φ10*20mm	C1
421	CB00067	electrolytic capacitor	470uF/35V φ10*20mm	C4,C5
422	HA01933	jump	2.5mm	R1-29,R2-29,J1-6,J2-6
423	CB00043	electrolytic capacitor	47uF/100V φ10*12mm	C1-1,C2-1
424	CB00056	electrolytic capacitor	220uF/25V φ8*11mm	C1-4,C2-4,C1-8,C2-8
425	AC00002	solder wire	63/37%	
426	MI01956	fixed bracket	MISTRAL900 1.5t*130*5*16mm left	
427	MJ00069	iron board	1.5*2135*1220 30.67kg	