

Service Manual

Model: α COMP

24x32 Bit Digital Compressor Module



www.altoproaudio.com

Version: 1.1

CONTENTS

- 1. Specification**
- 2. Block Diagram**
- 3. Schematic Diagram**
- 4. Printed Circuit Board**
- ~~**5. Wiring Diagram**~~
- 6. Test Procedure**
- 7. Electrical Parts List**
- 8. Exploded Views & Mechanical Parts List**
- 9. Notes**

1. SPECIFICATION (aCOMP)

Electrical

Frequency Response:	+0.5 / -1.5 dB from 20Hz to 20 kHz
S/N Ratio (process)	80 dB "A" wtg, 20 Hz-22kHz
S/N Ratio (bypass)	>90 dB "A" wtg, 20 Hz-22kHz
THD+Noise:	<0.008% @ 1kHz (0dBV, bypass)

Input

Number of Channels:	2
Format:	1/4" unbalanced
Maximum Level (bypass):	+9 dBu
Impedance:	>500 Kohms

A/D - D/A Conversions

A/D converter:	1 bit Sigma-Delta
D/A converter:	1 bit Sigma-Delta

Output

Number of Channels:	2
Format:	1/4" unbalanced
Maximum Level (bypass):	+9 dBu
Output Impedance:	<500 ohms

Front Panel

Controls	Input/Output Levels (ANALOG) PROGRAM selections (2 knobs)
Indicators	Power, Signal clip LED

Rear Panel

IN/OUT levels (ANALOG)	1/4" 2-conductor (mono)
Output (LEFT, RIGHT)	1/4" 2-conductor (mono)
BYPASS	1/4" 2-conductor (auto-sense pedal type) for momentary footswitches
Power	9 Volt AC Power Transformer

Processing and Memory

Processor Speed:	12 MIPS (million instructions per second)
Internal DSP resolution:	52 bit MPY accumulator
Main Preset Programs	16
Preset Total Combinations	256
Internal digital audio memory:	3000 milliseconds

Physical

Net Weight:	1kg(2.20lb)
Dimension(WxDxH):	200(mm) 150(mm) 45(mm) (7.87" x 5.91"x 1.77")

2. Block Diagram

alphaverb BLOCK DIAGRAM

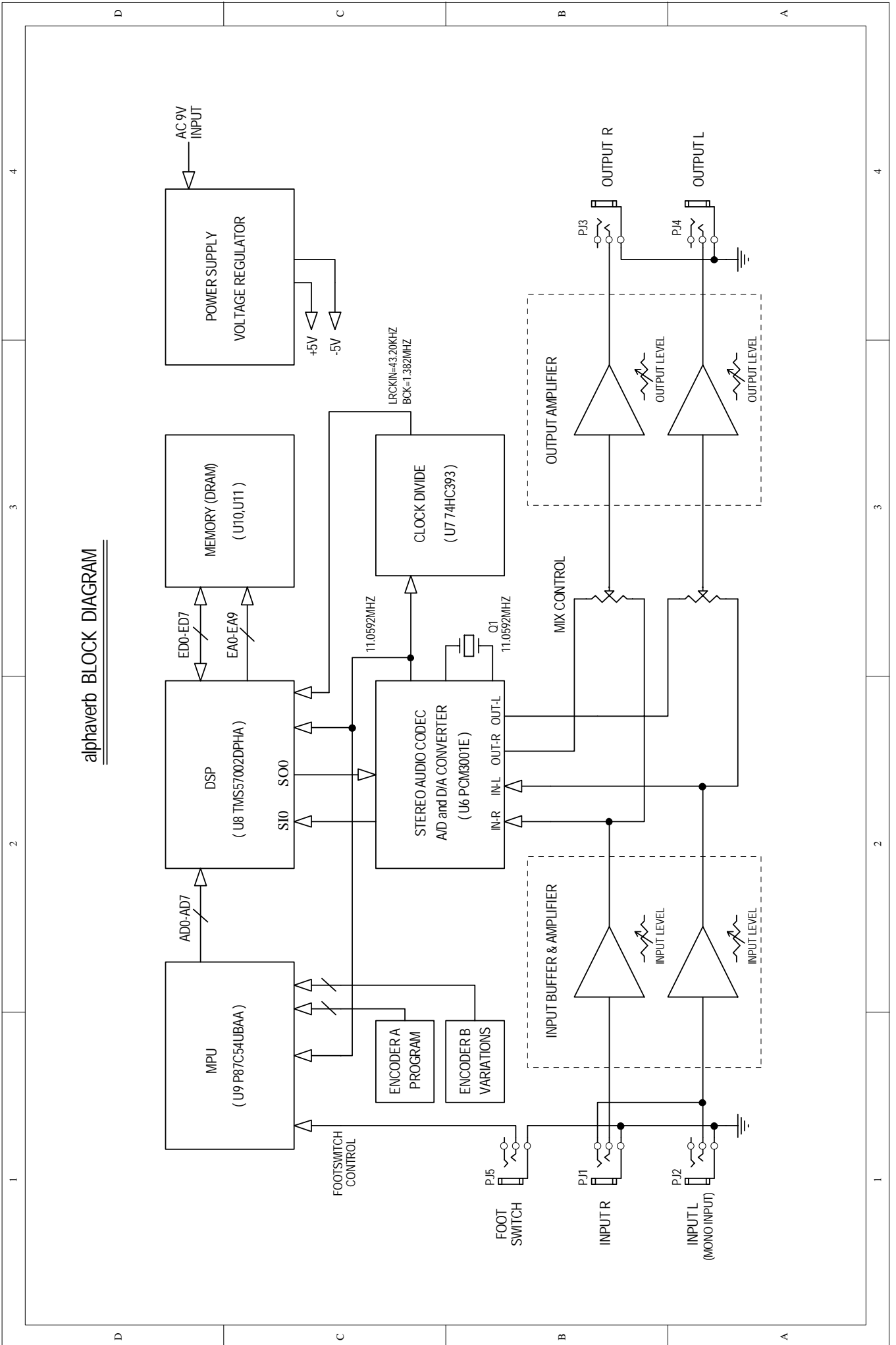

3. Schematic Diagram

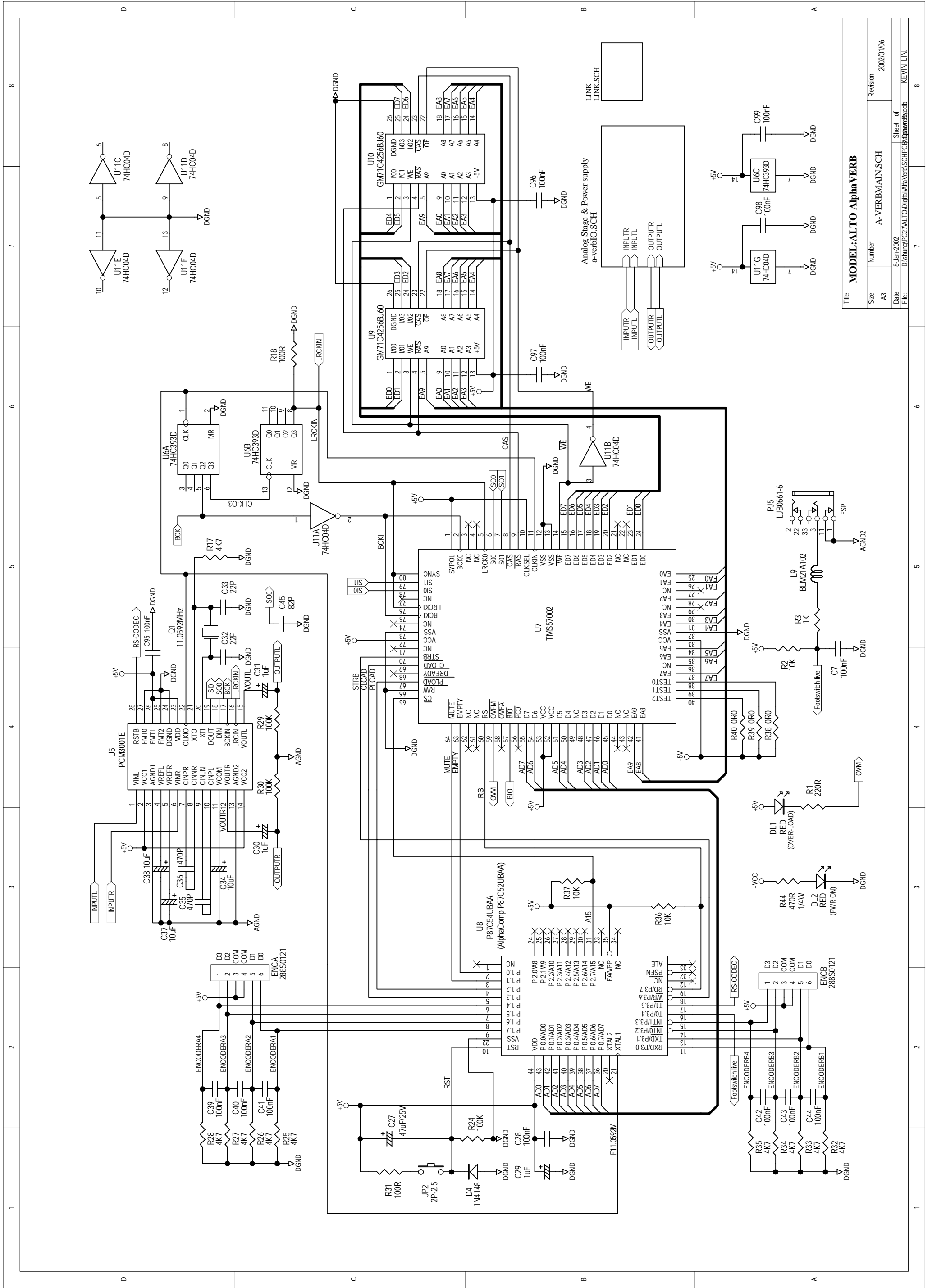

Title		MODEL:ALTO AlphaVerb	
Size	Number	A3	A-VERBMAIN.SCH
Date:	Revision	8-Jan-2002	2002/01/06
File:	Sheet of	D:\stung\PC7\VALTO\Digital\AlphaVerb\SCHPC7\AlphaVerb.dtb	8

1 2 3 4 5 6 7 8

1 2 3 4 5 6 7 8

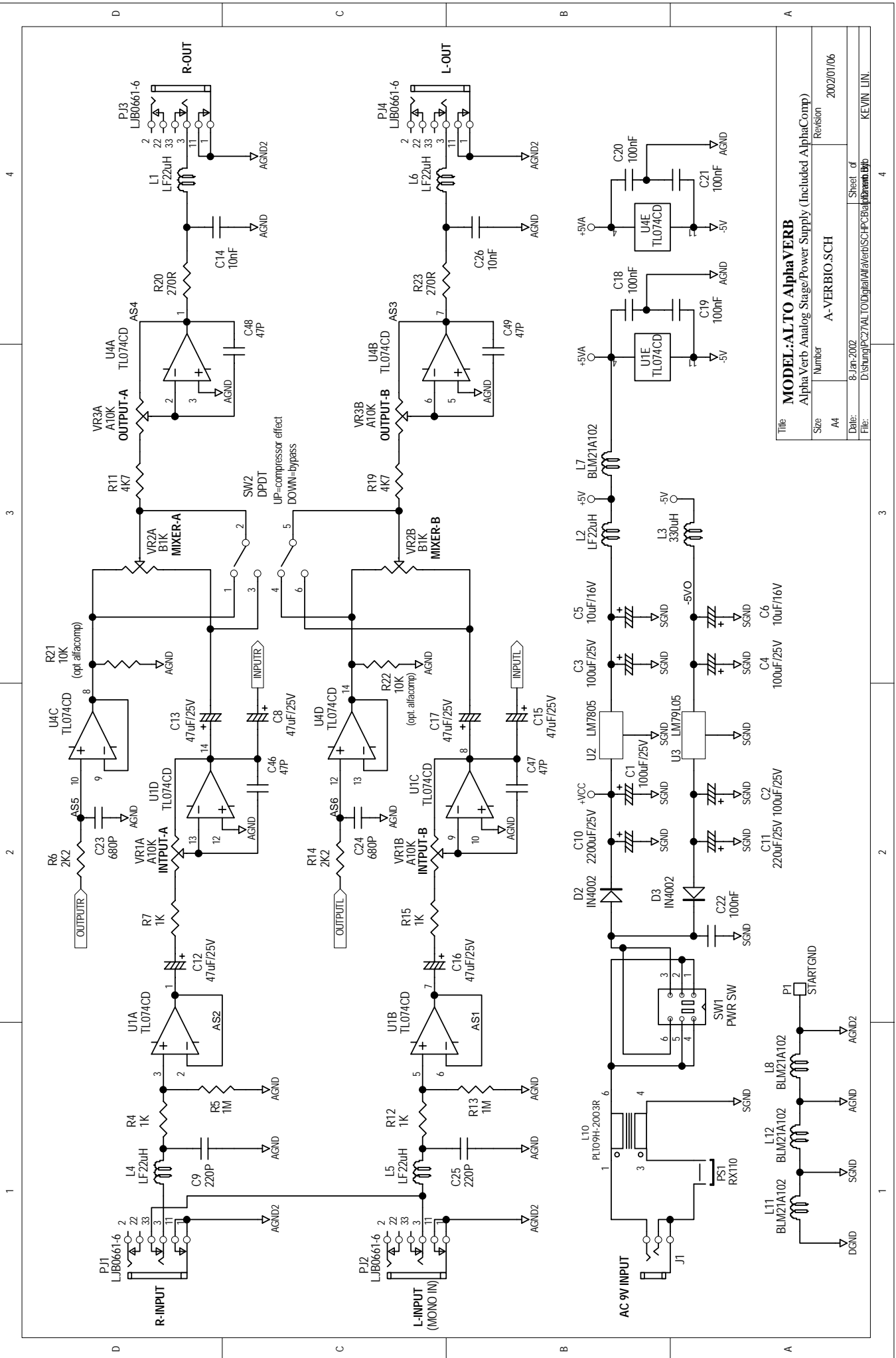

Title		MODEL:ALTO AlphaVerb	
Alpha Verb Analog Stage/Power Supply (Included AlphaComp)		Revision	
Size	Number	A4	2002/01/06
Date:	8-Jan-2002		Sheet of
File:	D:\shung\PC27\ALTO\Digital\AlphaVerb\SCH\PCB\alphaVerb.brd		4

Title		MODEL:ALTO AlphaVerb	
Alpha Verb Analog Stage/Power Supply (Included AlphaComp)		Revision	
Size	Number	A-VERBIO.SCH	2002/01/06
Date:	8-Jan-2002		Sheet of
File:	D:\shung\PC27\ALTO\Digital\AlphaVerb\SCH\PCB\alphaVerb.brd		4

Title		MODEL:ALTO AlphaVerb	
Alpha Verb Analog Stage/Power Supply (Included AlphaComp)		Revision	
Size	Number	A-VERBIO.SCH	2002/01/06
Date:	8-Jan-2002		Sheet of
File:	D:\shung\PC27\ALTO\Digital\AlphaVerb\SCH\PCB\alphaVerb.brd		4

4. Print Circuit Board

BOTTOM LAYER

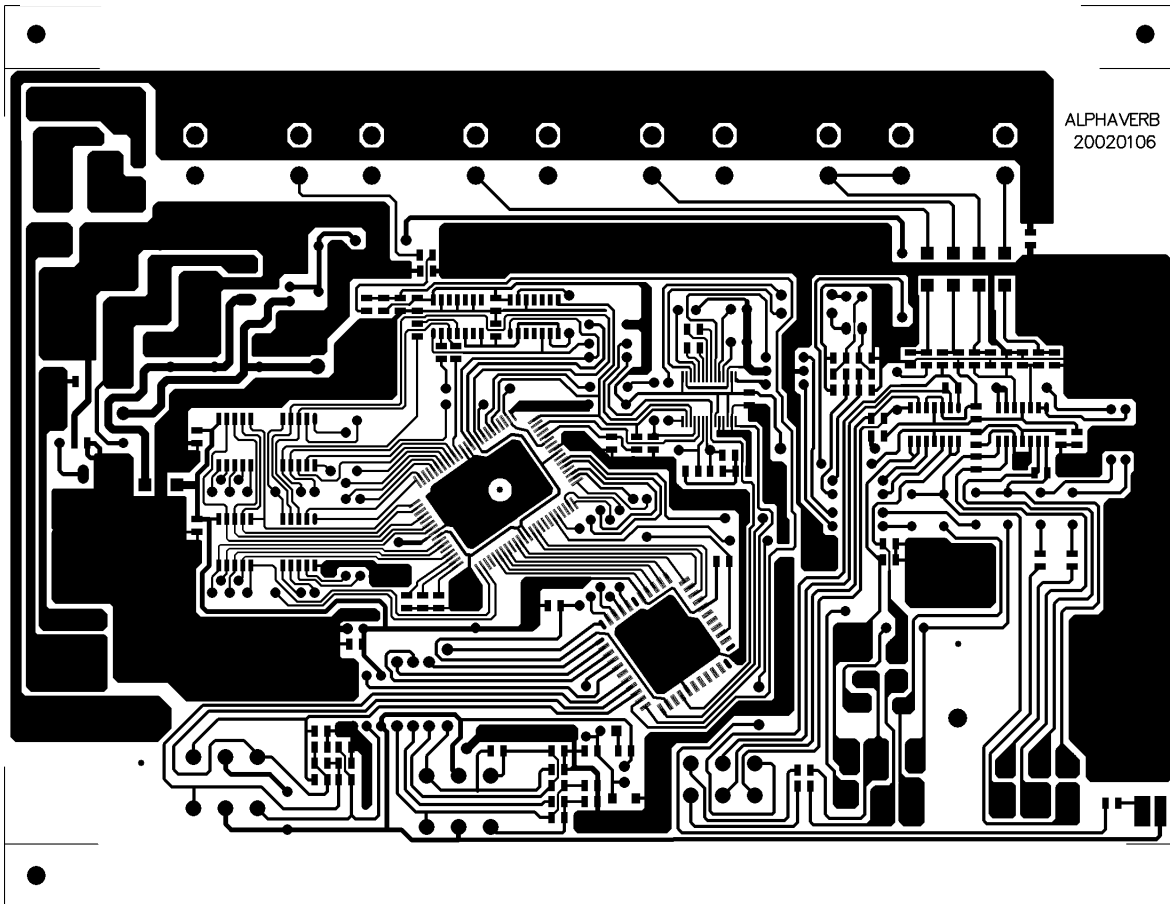

BOTTOM SOLDER MASK

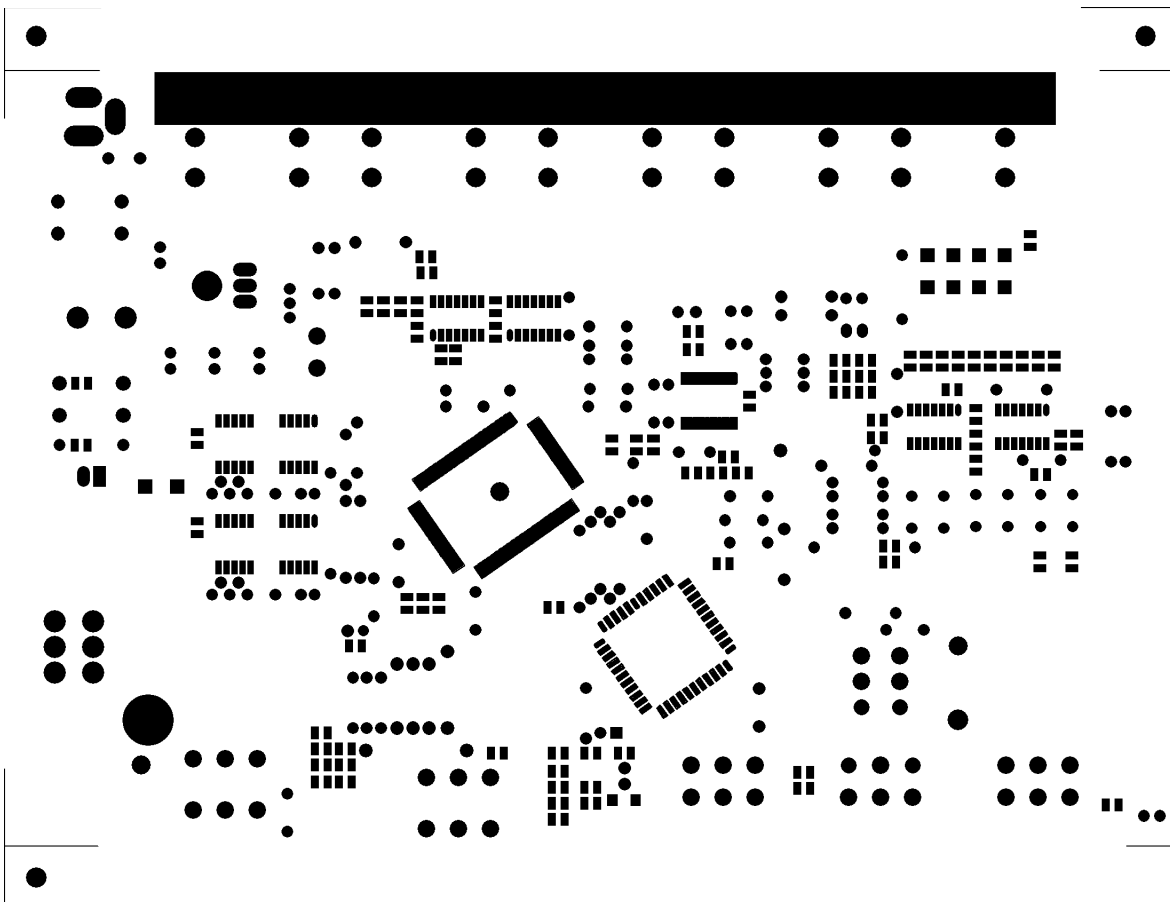

DRILL DRAWING

A = BUTTONHOLE 1.3*2.6-2HOLES
 B = BUTTONHOLE 1.3*3.3-1HOLES



Tool	Hole Size	Hole Count Plated
T1	31mil (0.80mm)	203
T2	39mil (1.00mm)	13
T3	47mil (1.20mm)	42
T4	59mil (1.50mm)	30
T5	98mil (2.50mm)	1
T6	118mil (3.00mm)	3
T7	138mil (3.50mm)	2
Totals		294

AlphaVerb
20020106

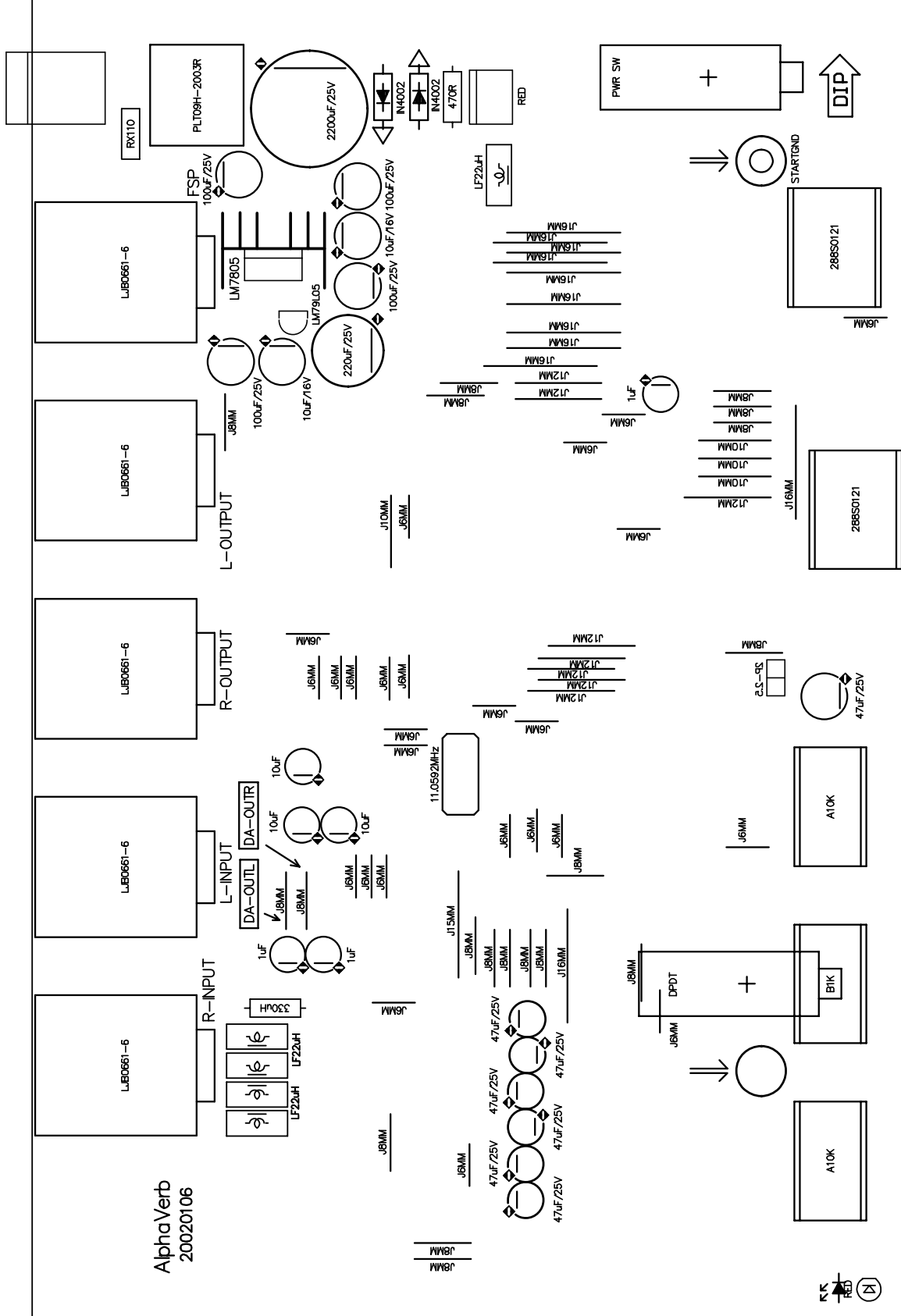

K.S.

G1 Test Procedures (aCOMP)

Required Equipment

Audio Precision System 2 with APWin software
100 Mhz oscilloscope connected to APS2 Analyzer Signal Monitor outputs (Ch. A and Ch. B)

Connection Mode

Use Audio Precision System 2 analog unbalanced (BNC) inputs/outputs.

Test Procedures for AlphaComp

Amplitude response test

On PC:

-Load file: **alfacomp_amplitude** (APWin File menu / Open / Test)

Test Connections:

- Output A of Audio Precision System Two --> LEFT input of the device under test.**
- LEFT output of the device under test --> A input of Audio Precision System Two**
- RIGHT output of the device under test --> B input of Audio Precision System Two**

On the Alphacomp:

- Turn on the power switch.
- Set INPUT volume to maximum.
- Set OUTPUT volume to maximum.
- Set PROGRAM to **AGC PURE**.
- Set VARIATION to 1.

Start the sweep (F9) and control the results (Page3 – Graph) in the following conditions:

- hardware bypass switch pressed.**
- hardware bypass switch released.**

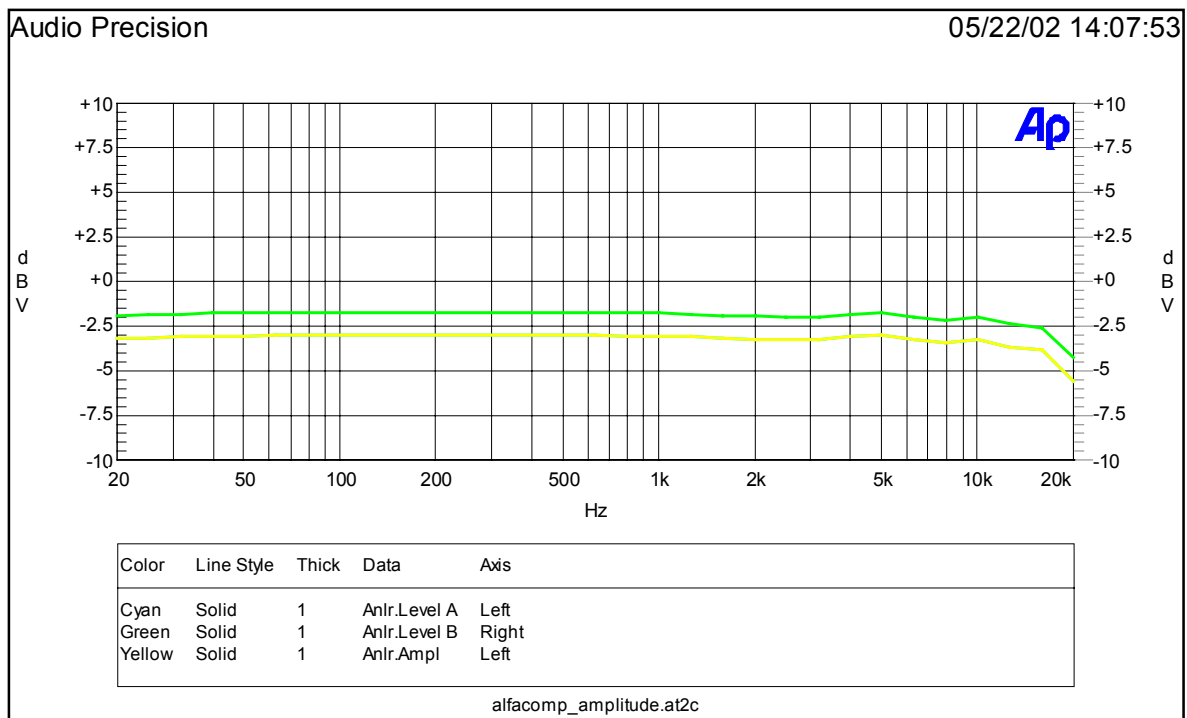

THD test

On PC:

-Load file: **alfacomp_THD** (APWin File menu / Open / Test)

Test Connections:

-Output A of Audio Precision System Two --> LEFT input of the device under test.

On the Alphacomp:

-Turn on the power switch.

-Set INPUT volume to maximum.

-Set OUTPUT volume to maximum.

-Set PROGRAM to **AGC PURE**.

-Set VARIATION to 1.

Start the sweep (F9) and control the results (Page3 – Graph) in the following conditions:

-LEFT output of the device under test --> A input of Audio Precision System Two / hardware bypass switch released.

-RIGHT output of the device under test --> B input of Audio Precision System Two / hardware bypass switch released.

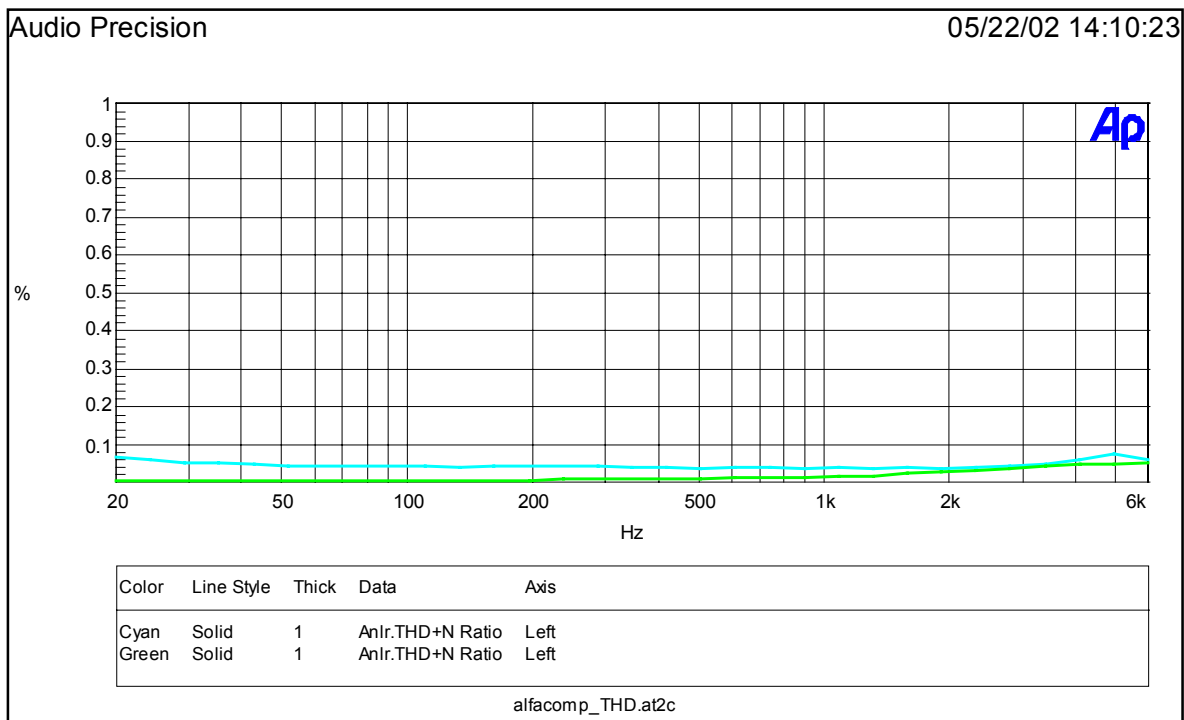

S/N test

On PC:

-Load file: **alfacomp_SN** (APWin File menu / Open / Test)

Test Connections:

-Output A of Audio Precision System Two --> LEFT input of the device under test.

On the Alphacomp:

-Turn on the power switch.

- With hardware bypass switch in COMP position and both outputs connected to the Audio Precision, increase the INPUT level until the device's outputs clip, and after reduce the INPUT level itself until the outputs exit from clipping state.

-Set OUTPUT volume to maximum.

-Set PROGRAM to **AGC PURE**.

-Set VARIATION to 1.

Start the sweep (F9) and control the results (Page3 – Graph) in the following conditions:

-LEFT output of the device under test --> A input of Audio Precision System Two / hardware bypass switch pressed.

-RIGHT output of the device under test --> B input of Audio Precision System Two / hardware bypass switch pressed.

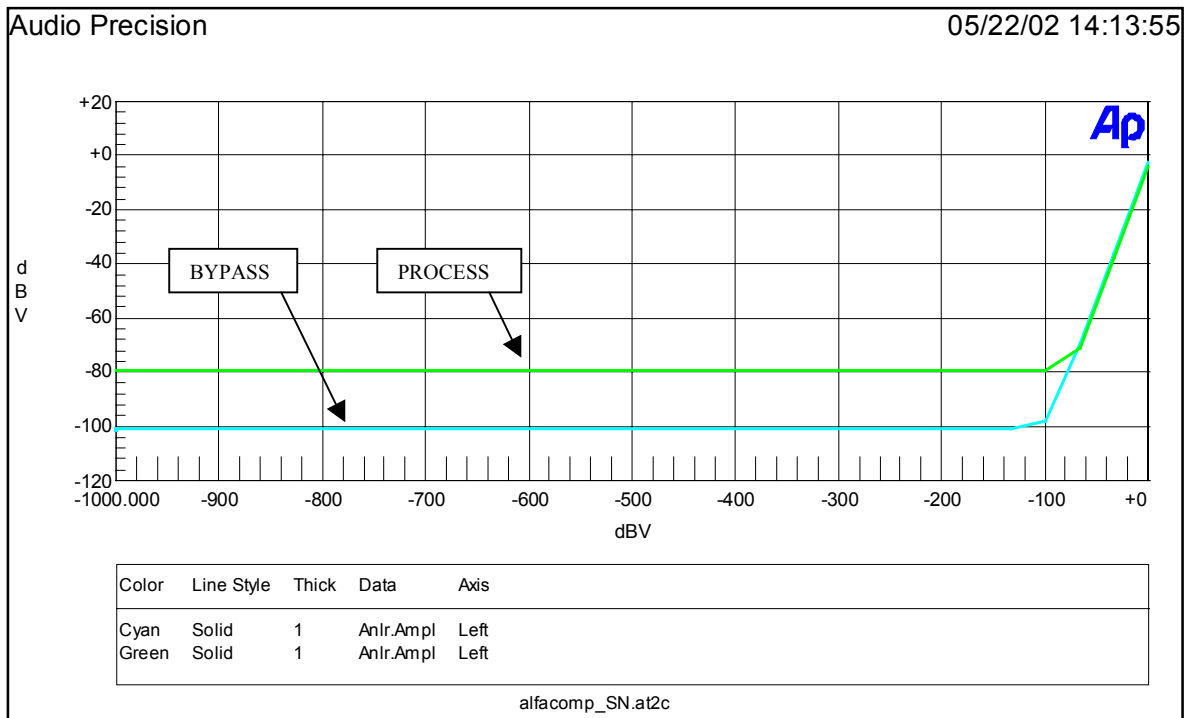

Dynamics test

On PC:

-Load file: **alfacomp_dyn** (APWin File menu / Open / Test)

Test Connections:

-**Output A of Audio Precision System Two --> LEFT input of the device under test.**

On the Alphacomp:

- Turn on the power switch.
- Set INPUT volume to maximum.
- Set OUTPUT volume to maximum.
- Set PROGRAM to **AGC PURE**.
- Set VARIATION to 1.

Start the sweep (F9) and control the results (Page3 – Graph) in the following conditions:

-**LEFT output of the device under test --> A input of Audio Precision System Two / hardware bypass switch pressed.**

-**RIGHT output of the device under test --> B input of Audio Precision System Two / hardware bypass switch pressed.**

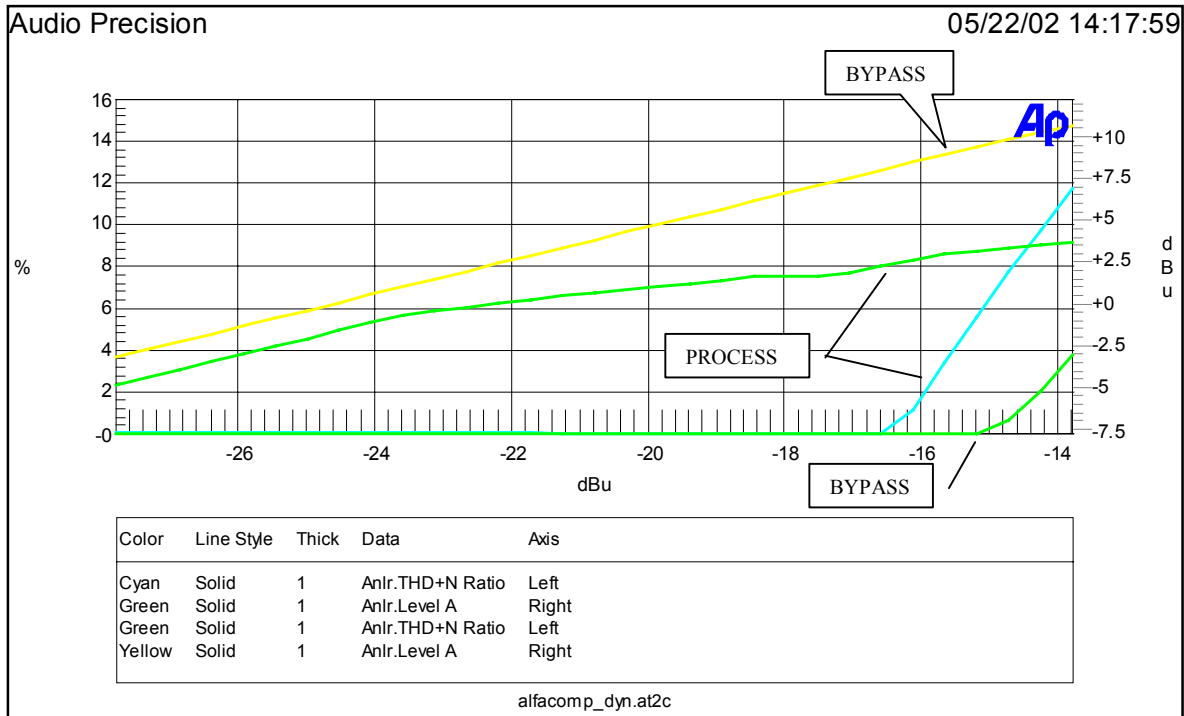

Stability test

On PC:

-Load file: **alfacomp_stability** (APWin File menu / Open / Test)

Test Connections:

- Output A of Audio Precision System Two --> LEFT input of the device under test.**
- LEFT output of the device under test --> A input of Audio Precision System Two**
- RIGHT output of the device under test --> B input of Audio Precision System Two**

On the Alphacomp:

- Turn on the power switch.
- Set OUTPUT volume to maximum.
- Set PROGRAM to **AGC PURE**.
- Set hardware bypass switch to BYPASS (released).
- Set VARIATION to 1.

Test:

Move the input level knob from 0 to maximum 3 times and control the output waveforms: NO PERMANENT SINE WAVEFORMS should be visible. IF PERMANENT WAVEFORMS WITH FREQUENCY > 20 kHz should become visible on whatever output channel, THE UNIT IS TO BE INSPECTED.

Multi-Level BOM Structure Listing

Report No.: IEBO_P02
 Prepared by 000011[YAFEN]
 Item No. PF00076 Version
 DESCRIPTIO aCOMP

Date 2003/08/20
 Page No.: 1/9

UNIT: PCS
 Date: 2002/04/16

aCOMP_ALTO_230V_歐規_無

Version	Item No	Loss %	Ver.	Unit	Cardinal	Effective Date
Component Remark	Item Description				Usage Rate	@:Phantom Layer Attrition Rate
0001-----	MA02918 panel(white) Comp LTO			PCS	1.0000 1 0.00 %	2002/04/16 N
0002-----	MB01615 bottom board a verb			PCS	1.0000 1 0.00 %	2002/04/16 N
0003-----	MC00371 top cover aVERB			PCS	1.0000 1 0.00 %	2002/04/16 N
0004-----	MB01957 rear board a verb			PCS	1.0000 1 0.00 %	2002/04/16 N
0005-----	NI00363 plastic knob 21*16			PCS	1.0000 1 0.00 %	2002/04/16 N
0006-----	NI00362 plastic knob (COOL GRAY 8C/white)			PCS	3.0000 1 0.00 %	2002/04/16 N
0007-----	NI00896 knob cover-ABS 8.5*4 bule 072C			PCS	3.0000 1 0.00 %	2002/04/16 N
0008-----	NI00307 power sw bottom 15*12			PCS	1.0000 1 0.00 %	2002/04/16 N
0009-----	NI01160 power switch cap 14.5*10 YELLOW C			PCS	1.0000 1 0.00 %	2002/04/16 N
0010-----	NI00314 power sw bottom 6.5*16(inner 3.3*3.3)black			PCS	1.0000 1 0.00 %	2002/04/16 N
0011-----	MG00025 screw M3*6			PCS	10.0000 1 0.00 %	2002/04/16 N
0012-----	MG00163 Ni-screw M3*8			PCS	2.0000 1 0.00 %	2002/04/16 N
0013-----	MG00045 screw M3*7			PCS	4.0000 1 0.00 %	2002/04/16 N
0014-----	NI00002 nut of plastic-HC00108 Appendix 7/16"*G20/15*4.8(hexagon)			PCS	5.0000 1 0.00 %	2002/04/16 N
0015-----	MF00014 outter gear washer 3* 6.5*0.5t			PCS	2.0000 1 0.00 %	2002/04/16 N

Multi-Level BOM Structure Listing

Report No.: IEBO_P02
 Prepared by 000011[YAFEN]
 Item No. PF00076 Version
 DESCRIPTIO aCOMP

Date 2003/08/20
 Page No.: 2/9

UNIT: PCS
 Date: 2002/04/16

aCOMP_ALTO_230V_歐規_無

Version	Item No Item Description	Loss %	Ver.	Unit	Cardinal Usage Rate	Effective Date @:Phantom Layer Attrition Rate
0016-----	HA01388 row-wire connector wiring 2P 100			PCS	1.0000 1 0.00 %	2002/04/16 N
0017-----	NC00131 washer 1* 11.3* 15.3 red			PCS	5.0000 1 0.00 %	2002/05/05 N
0018-----	SA00065 L.E.D LG2043 green			PCS	1.0000 1 0.00 %	2002/05/05 N
0019-----	NI00240 sleeving flame retardant 2.5*10mm			PCS	2.0000 1 0.00 %	2002/05/05 N
0020-----	TG00023 voltage transformer 230V/50Hz_AC9V/300mA_ET-35_CE			PCS	1.0000 1 0.00 %	2002/05/05 N
0021-----	NF00124 instruction aCOMP			PCS	1.0000 1 0.00 %	2002/05/05 N
0022-----	HJ00002 desiccant 10g			PCS	1.0000 1 0.00 %	2002/05/05 N
0023-----	NA00122 PE bag 0.04t*350*230mm		KG	PCS	1.0000 1 0.00 %	2002/05/05 N
0024-----	NA00137 clip-chain bag 5*7			PCS	1.0000 1 0.00 %	2002/05/05 N
0025-----	NI01825 ZD-cushion-aVERB-10 0.5* 3.3* 8.3 aVERB			PCS	1.0000 1 0.00 %	2002/05/05 N
0026-----	NA00146 bubble bag 13*16			PCS	1.0000 1 0.00 %	2002/05/05 N
0027-----	NI00501 foot cushion 12.7*9*3t(SF-004)			PCS	4.0000 1 0.00 %	2002/05/05 N
0028-----	NI02085 power switch fixed sleeve 22*9.69 072C blue			PCS	1.0000 1 0.00 %	2002/07/19 N
0029-----	NE03118 program adhesive paper 12*9mm aCOMP CKS:C47F			PCS	1.0000 1 0.00 %	2002/07/19 N
0030-----	NB01480 colour box aCOMP ALTO			PCS	1.0000 1 0.00 %	2002/07/19 N

Multi-Level BOM Structure Listing

Report No.: IEBO_P02
 Prepared by 000011[YAFEN]
 Item No. PF00076 Version
 DESCRIPTIO aCOMP

Date 2003/08/20
 Page No.: 3/9

UNIT: PCS
 Date: 2002/04/16

aCOMP_ALTO_230V_歐規_無

Version	Item No Item Description	Loss %	Ver.	Unit	Cardinal Usage Rate	Effective Date @:Phantom Layer Attrition Rate
0031-----	NB02141 outter carton 8 hole aVERB aCOMP aMICTUBE ALTO			PCS	1.0000 8 0.00 %	2002/12/05 N
0032-----	MI00408 conduct electricity board aVERB			PCS	1.0000 1 0.00 %	2002/07/19 N
0033-----	NE05008 ZC-bar shape code abhesive paper 30*11m ACOMP			PCS	4.0000 1 0.00 %	2002/07/19 N
0034-----	NE05004 number bar shape adhevis paper 30*11mr ALTO PF			PCS	4.0000 1 0.00 %	2002/07/19 N
0035-----	HK00337 PC board P-aCOMP-DIP			PCS	1.0000 1 0.00 %	2002/07/19 N
0001-----	RA00204 fixed resistor 1/4W 470 M type R44			PCS	1.0000 1 0.00 %	2002/04/16 N
0002-----	CB00009 electrolytic capacitor 1uF/50V 4*7mm C29 C30 C31			PCS	3.0000 1 0.00 %	2002/04/16 N
0003-----	CB00024 electrotytic capacitor 10uF/16V 4*7mm R34 R37 R38 R5 R6			PCS	5.0000 1 0.00 %	2002/04/16 N
0004-----	CB00040 electrotytic capacitor 47uF/25V 5*11mm C12 C13 C15 C16 C17 C8			PCS	6.0000 1 0.00 %	2002/04/16 N
0005-----	CB00039 electrotytic capacitor 47uF/25V 5*11mm C27			PCS	1.0000 1 0.00 %	2002/04/16 N
0006-----	CB00047 electrotytic capacitor 100uF/25V 6*11mm C1 C2 C3 C4			PCS	4.0000 1 0.00 %	2002/04/16 N
0007-----	CB00056 electrolytic capacitor 220uF/25V 8*11mm C11			PCS	1.0000 1 0.00 %	2002/04/16 N
0008-----	CB00080 electrotytic capacitor 2200uF/25V 16*25mm			PCS	1.0000 1 0.00 %	2002/04/16 N

Multi-Level BOM Structure Listing

Report No.: IEBO_P02
 Prepared by 000011[YAFEN]
 Item No. PF00076 Version
 DESCRIPTIO aCOMP

Date 2003/08/20
 Page No.: 4/9

UNIT: PCS
 Date: 2002/04/16

aCOMP_ALTO_230V_歐規_無

Version	Item No	Loss %	Ver.	Unit	Cardinal	Effective Date
Component Remark	Item Description				Usage Rate @:	Phantom Layer Attrition Rate
	C10					
0009-----	SA00094				2.0000	2002/04/16
	rectifier diode			PCS	1	N
	1N4002/100V				0.00 %	
	D2 D3					
0010-----	SD00074				1.0000	2002/04/16
	integrated circuit			PCS	1	N
	7805(TO-220)				0.00 %	
	U2					
0011-----	SB00083				1.0000	2002/04/16
	voltage stabilized transistor			PCS	1	N
	79L05(TO-92)				0.00 %	
	U3					
0012-----	SC00002				1.0000	2002/04/16
	quartz crystalloid			PCS	1	N
	11.0592MHZ HC-49/US ±20PPM				0.00 %	
	Q1					
0013-----	CN00026				1.0000	2002/04/16
	inductor			PCS	1	N
	330uH(LGA0307-331K)				0.00 %	
	L3					
0014-----	CG00018				5.0000	2002/04/16
	filter-EMI FILTER			PCS	1	N
	LF-22UH(WAH TAYI)				0.00 %	
	L1 L2 L4 L5 L6					
0015-----	HI00073				2.0000	2002/04/16
	waveband switch			PCS	1	N
	288S0121				0.00 %	
0016-----	HI00047				1.0000	2002/04/16
	button SW(double link-action))			PCS	1	N
	PS-9AN-022-18B long foot				0.00 %	
	SW1					
0017-----	HI00051				1.0000	2002/04/16
	key swith (double-link)			PCS	1	N
	PS-9AN-022-18A				0.00 %	
	SW2					
0018-----	RC00086				2.0000	2002/04/16
	potentiometer			PCS	1	N
	A10K *2 RV16A01-20-20F-A14-301				0.00 %	
	VR1 VR3					
0019-----	HC00108				5.0000	2002/04/16
	MIC jack			PCS	1	N
	6.3 stereo LJB0661-6				0.00 %	
	PJ1 PJ2 PJ3 PJ4 PJ5					
0020-----	HC00183				1.0000	2002/04/16
	DC jack			PCS	1	N

Multi-Level BOM Structure Listing

Report No.: IEBO_P02
 Prepared by 000011[YAFEN]
 Item No. PF00076 Version
 DESCRIPTIO aCOMP

Date 2003/08/20
 Page No.: 5/9

UNIT: PCS
 Date: 2002/04/16

aCOMP_ALTO_230V_歐規_無

Version	Item No	Loss %	Ver.	Unit	Cardinal	Effective Date
Component Remark	Item Description				Usage Rate @:	Phantom Layer Attrition Rate
	DJ-005A				0.00 %	
	J1					
0021-----	SA00053				1.0000	2002/04/16
	L.E.D high intensity			PCS	1	N
	3m/m round(red)long foot 26mm				0.00 %	
	DL1					
0022-----	NI01776				1.0000	2002/04/16
	LED separating pillar			PCS	1	N
	LED-3 3mm				0.00 %	
0023-----	HC00076				1.0000	2002/04/16
	row-wire header			PCS	1	N
	2P 2.5mm 180°				0.00 %	
	DL2					
0024-----	HC00134				1.0000	2002/04/16
	row-pin(single)#1100			PCS	1	N
	2.54 180° 2P(gold-plated) 6/11.6mm				0.00 %	
	JP2					
0025-----	CG00024				1.0000	2002/04/16
	filter-EMI FITER			PCS	1	N
	PLT09H-2003R				0.00 %	
	L10					
0026-----	MI00256				1.0000	2002/04/16
	heat-sink			PCS	1	N
	25*15*10.6-1PIN SCL-2020				0.00 %	
0027-----	MG00160				1.0000	2002/04/16
	Ni-screw			PCS	1	N
	M3*6 P0.5				0.00 %	
0028-----	MF00037				1.0000	2002/04/16
	spring washer			PCS	1	N
	3* 5*1t				0.00 %	
0029-----	NC00005				1.0000	2002/04/16
	silicone insulator			PCS	1	N
	TO-220 square type				0.00 %	
0030-----	NE03118				1.0000	2002/04/16
	ZC-program adhesive paper 12*9mm			PCS	1	N
	aCOMP CKS:C47F				0.00 %	
0031-----	HK01577				1.0000	2003/07/29
	PC board			PCS	1	
	P-aCOMP-AI				0.00 %	
0001-----	HA01920				25.0000	2003/07/14
	jumper wire			PCS	1	N
	6mm				0.00 %	
	JP10 JP11 JP12 JP13 JP14 JP16 JP17 JP18 JP19 JP20 JP21JP22 JP23 JP24					
	JP26 JP3 JP37 JP42 JP47 JP48 JP49 JP50 JP64 JP70 JP8					
0002-----	HA01922				19.0000	2003/07/14
	jumper wire			PCS	1	N

Multi-Level BOM Structure Listing

Report No.: IEBO_P02 Date: 2003/08/20
 Prepared by 000011[YAFEN] Page No.: 6/9
 Item No. PF00076 Version UNIT: PCS
 DESCRIPTIO aCOMP Date: 2002/04/16
 aCOMP_ALTO_230V_歐規_無

Version	Item No	Loss %	Ver.	Unit	Cardinal	Effective Date
Component Remark	Item Description				Usage Rate @:	Phantom Layer
					Attrition Rate	
	8mm				0.00 %	
	JP27 JP28 JP29 JP30 JP31 JP32 JP33 JP34 JP35 JP36 JP39 JP4 JP40 JP41					
	JP5 JP6 JP67 JP7 JP9					
0003-----	HA01925				4.0000	2003/07/14
	jumper wire			PCS	1	N
	10mm				0.00 %	
	JP25 JP43 JP44 JP45					
0004-----	HA01928				8.0000	2003/07/14
	jumper wire			PCS	1	N
	12mm				0.00 %	
	JP46 JP51 JP52 JP53 JP54 JP62 JP68 JP71					
0005-----	HA01930				1.0000	2003/07/14
	jumper wire			PCS	1	N
	15mm				0.00 %	
	J65					
0006-----	HA01931				11.0000	2003/07/14
	jumper wire			PCS	1	N
	16mm				0.00 %	
	JP38 JP55 JP56 JP57 JP58 JP59 JP60 JP61 JP63 JP66 JP69					
0007-----	HK00338				1.0000	2003/07/14
	PC board			PCS	1	Y
	P-aCOMP-SMD				0.00 %	
0001-----	HB00007				1.0000	2002/04/16
	PCB-CEM-1			PCS	1	N
	ALPHAVERB_VER030517				0.00 %	
0002-----	RD00002				10.0000	2002/04/16
	SMDfixed resistor 1/10W			PCS	1	N
	0 ±5% 0805				0.00 %	
	JR1 JR10 JR11 JR12 JR4 JR6 JR7 JR38 JR39 JR40					
0003-----	RD00006				2.0000	2002/04/16
	SMDfixed resistor 1/10W			PCS	1	N
	100 ±5% 0805				0.00 %	
	R18 R31					
0004-----	RD00009				1.0000	2002/04/16
	SMDfixed resistor 1/10W			PCS	1	N
	220 ±5% 0805				0.00 %	
	R1					
0005-----	RD00010				2.0000	2002/04/16
	SMDfixed resistor 1/10W			PCS	1	N
	270 ±5% 0805				0.00 %	
	R20 R23					
0006-----	RD00018				5.0000	2002/04/16
	SMDfixed resistor 1/10W			PCS	1	N
	1.0K ±5% 0805				0.00 %	
	R12 R15 R3 R4 R7					
0007-----	RD00023				2.0000	2002/04/16

Multi-Level BOM Structure Listing

Report No.: IEBO_P02
 Prepared by 000011[YAFEN]
 Item No. PF00076 Version
 DESCRIPTIO aCOMP

Date 2003/08/20
 Page No.: 7/9

UNIT: PCS
 Date: 2002/04/16

aCOMP_ALTO_230V_歐規_無

Version	Item No	Loss %	Ver.	Unit	Cardinal	Effective Date
Component Remark	Item Description				Usage Rate @:	Phantom Layer
					Attrition Rate	
	SMDfixed resistor 1/10W 2.2K ±5% 0805 R14 R6			PCS	1 0.00 %	N
0008-----	RD00027				11.0000	2002/04/16
	SMDfixed resistor 1/10W 4.7K ±5% 0805 R11 R17 R19 R25 R26 R27 R28 R32 R33 R34 R35			PCS	1 0.00 %	N
0009-----	RD00032				5.0000	2002/04/16
	SMDfixed resistor 1/10W 10K ±5% 0805 R2 R21 R22 R36 R37			PCS	1 0.00 %	N
0010-----	RD00049				3.0000	2002/04/16
	SMDfixed resistor 1/10W 100K ±5% 0805 R24 R29 R30			PCS	1 0.00 %	N
0011-----	RD00056				2.0000	2002/04/16
	SMDfixed resistor 1/10W 1.0M ±5% 0805 R13 R5			PCS	1 0.00 %	N
0012-----	CI00007				2.0000	2002/04/16
	SMDceramic capacitor0805 22PF/50V NPO C32 C33			PCS	1 0.00 %	N
0013-----	CI00012				4.0000	2002/04/16
	SMDceramic capacitor0805 47PF/50V NPO C46 C47 C48 C49			PCS	1 0.00 %	N
0014-----	CI00015				1.0000	2002/04/16
	SMD ceramic capacitor0805 82PF/50V NPO C45			PCS	1 0.00 %	N
0015-----	CI00018				2.0000	2002/04/16
	SMDceramic capacitor0805 220PF/50V NPO ±5% C25 C9			PCS	1 0.00 %	N
0016-----	CI00019				2.0000	2002/04/16
	SMDceramic capacitor0805 470PF/50V NPO ±5% C35 C36			PCS	1 0.00 %	N
0017-----	CI00020				2.0000	2002/04/16
	SMDceramic capacitor0805 680PF/50V NPO C23 C24			PCS	1 0.00 %	N
0018-----	CI00028				2.0000	2002/04/16
	SMDceramic capacitor0805 0.01uF/50V Y5V			PCS	1 0.00 %	N

Multi-Level BOM Structure Listing

Report No.: IEBO_P02 Date: 2003/08/20
 Prepared by 000011[YAFEN] Page No.: 8/9
 Item No. PF00076 Version UNIT: PCS
 DESCRIPTIO aCOMP Date: 2002/04/16
 aCOMP_ALTO_230V_歐規_無

Version	Item No	Loss %	Ver.	Unit	Cardinal	Effective Date
Component Remark	Item Description				Usage Rate @:	Phantom Layer
					Attrition Rate	
	C14 C26					
0019-----	CI00029				18.0000	2002/04/16
	SMDceramic capacitor0805			PCS	1	N
	0.1uF/50V Y5V				0.00 %	
	C18 C19 C20 C21 C22 C28 C39 C40 C41 C42 C43 C44 C7 C95 C96 C97 C98 C99					
0020-----	SE00011				1.0000	2002/04/16
	SMD rectifier diode			PCS	1	N
	RLS4148 0.5A (LL-34)				0.00 %	
	D4					
0021-----	SG00067				1.0000	2002/04/16
	SMD integrated circuit			PCS	1	N
	74HC04DT				0.00 %	
	U11					
0022-----	SG00070				1.0000	2002/04/16
	SMD integratd circuit			PCS	1	N
	74HC393DT				0.00 %	
	U6					
0023-----	SG00001				2.0000	2002/04/16
	SMD integrated circuit			PCS	1	N
	TL074CDT				0.00 %	
	U1 U4					
0024-----	SG00036				1.0000	2002/04/16
	SMD integratd circuit			PCS	1	N
	PCM3001E				0.00 %	
	U5					
0025-----	SG00088				1.0000	2002/04/16
	SMD integratd circuit			PCS	1	N
	P87C52SBAA(UBAA)				0.00 %	
	U8					
0026-----	SG00114				1.0000	2002/04/16
	smd integrated circut			PCS	1	N
	TMS57002DPHA				0.00 %	
	U7					
0027-----	SG00115				2.0000	2002/04/16
	smd integrated circut			PCS	1	N
	MB81C4256A-60PJ				0.00 %	
	U10 U9					
0028-----	CO00006				5.0000	2002/04/16
	SMD inductor			PCS	1	N
	BLM21A102SPT				0.00 %	
	L11 L12 L7 L8 L9					
0036-----	NE05249				1.0000	2002/12/24
	ZC- program adhesive paper 30*11mm			PCS	1	
	aCOMP				0.00 %	
0037-----	NI02408				3.0000	2003/03/05

Multi-Level BOM Structure Listing

Report No.: IEBO_P02
 Prepared by 000011[YAFEN]
 Item No. PF00076 Version
 DESCRIPTION aCOMP
 aCOMP_ALTO_230V_歐規_無

Date 2003/08/20
 Page No.: 9/9

UNIT: PCS
 Date: 2002/04/16

Version	Item No	Loss %	Ver.	Unit	Cardinal	Effective Date
Component Remark	Item Description				Usage Rate @:	Phantom Layer
					Attrition Rate	
	fixed piece-ABS			PCS	1	
	15*2.7mm white CONTROL30				0.00 %	
0038-----	NI02409				1.0000	2003/03/05
	fixed piece-ABS			PCS	1	
	25*2.5mm aVERB				0.00 %	
0039-----	NF00061				1.0000	2003/05/15
	assurance card			PCS	1	
	ALTO				0.00 %	

8. Exploded Views

機種: averb
圖號: averb-00
日期: 20020124

