

NOTE: SET BIAS VOLTAGE FROM COLD START ACROSS R72 - R75 , 15 -20 mV DC AVERAGE , NO SIGNAL, NO LOAD.

TEST POINT CONDITIONS NOTE :  
 1 KHz INPUT SINEWAVE 170mV @ 0 dB INPUT JACK. 120VAC LINE, VOLUME & LEVEL @ "10" TONES @ "5" , DC VOLTAGES WITH NO SIGNAL APPLIED.

CAUTION:  
 THIS SCHEMATIC IS PROVIDED FOR USE BY QUALIFIED PERSONNEL. TO AVOID RISK OF ELECTRIC SHOCK, REFER SERVICING TO QUALIFIED SERVICE PERSONNEL. DO NOT PERFORM ANY SERVICING BEYOND THAT EXPLAINED IN THE OPERATING INSTRUCTIONS.

NOTES:  
 1) CAUTION: SHOCK HAZARD!! THIS UNIT CONTAINS HAZARDOUS VOLTAGE. DISCONNECT POWER AND BE SURE POWER SUPPLY IS DISCHARGED BEFORE TOUCHING INTERNAL PARTS.  
 2) UNLESS NOTED, RESISTOR VALUES IN OHMS, 1/4W-5% TOL. CAPACITOR VALUES IN MICROFARADS, 50V-10% TOL.  
 3) VOLTAGES ARE MEASURED WITH 1 MEGOHM OSCILLOSCOPE AND 10 MEGOHM DIGITAL VOLTMETER.

REV	Date	DESCRIPTION	Ecr(s)/Ecn(s)	Chgd By	Appvd by	Date
0	03/23/06	CONTROL ISSUE		WFB		
D	2-15-06	ADDED R7	R01852	RLB		
C	2-2-06	CHANGED J14 TO J19 ON WIRING DIAGRAM	R01846	RLB		
B	01/04/06	CHG C55 P/N, DEL DNP NOTES	R01838	WFB		
A	12-29-05	INITIAL ISSUE				

THE INFORMATION CONTAINED ON THIS DRAWING IS PROPRIETARY TO ST. LOUIS MUSIC, INC

Signatures:		Date:	 1901 Congressional, St. Louis, MO 63146
Drawn:	RLB	5-9-05	
Checked:			First Used On:
Released:			
Plot Date: Thu Mar 23, 2006	Drawing Size: C	Drawing Title: BASS AMP	
Plot Time: 14:45:37	Drawing Type: Schematic	Drawing Number: 07S697	
Tolerance:	Class Code: NONE	Sheet 1 of 3	

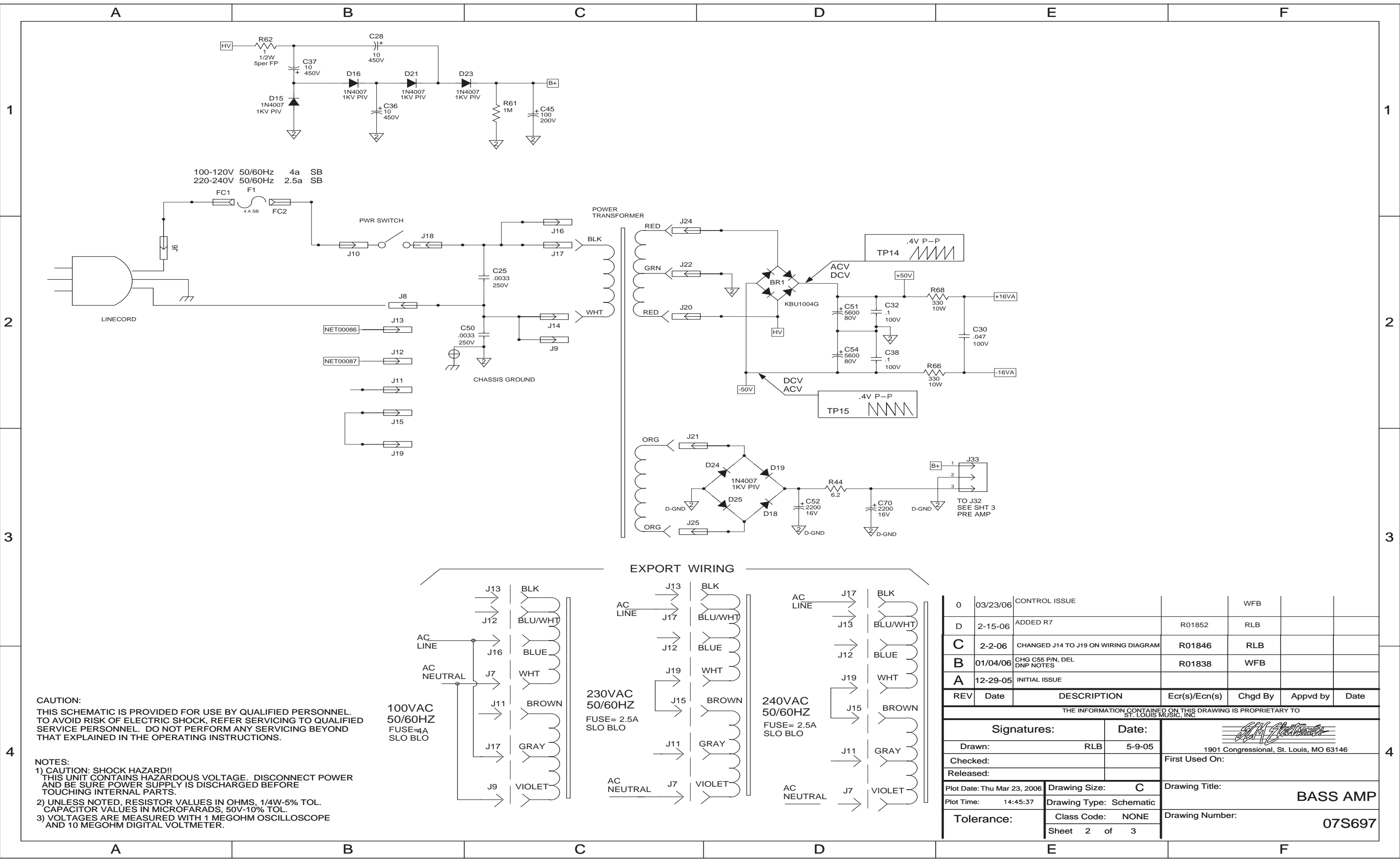

**CAUTION:**  
THIS SCHEMATIC IS PROVIDED FOR USE BY QUALIFIED PERSONNEL. TO AVOID RISK OF ELECTRIC SHOCK, REFER SERVICING TO QUALIFIED SERVICE PERSONNEL. DO NOT PERFORM ANY SERVICING BEYOND THAT EXPLAINED IN THE OPERATING INSTRUCTIONS.

**NOTES:**  
1) CAUTION: SHOCK HAZARD!! THIS UNIT CONTAINS HAZARDOUS VOLTAGE. DISCONNECT POWER AND BE SURE POWER SUPPLY IS DISCHARGED BEFORE TOUCHING INTERNAL PARTS.  
2) UNLESS NOTED, RESISTOR VALUES IN OHMS, 1/4W-5% TOL. CAPACITOR VALUES IN MICROFARADS, 50V-10% TOL.  
3) VOLTAGES ARE MEASURED WITH 1 MEGOHM OSCILLOSCOPE AND 10 MEGOHM DIGITAL VOLTMETER.

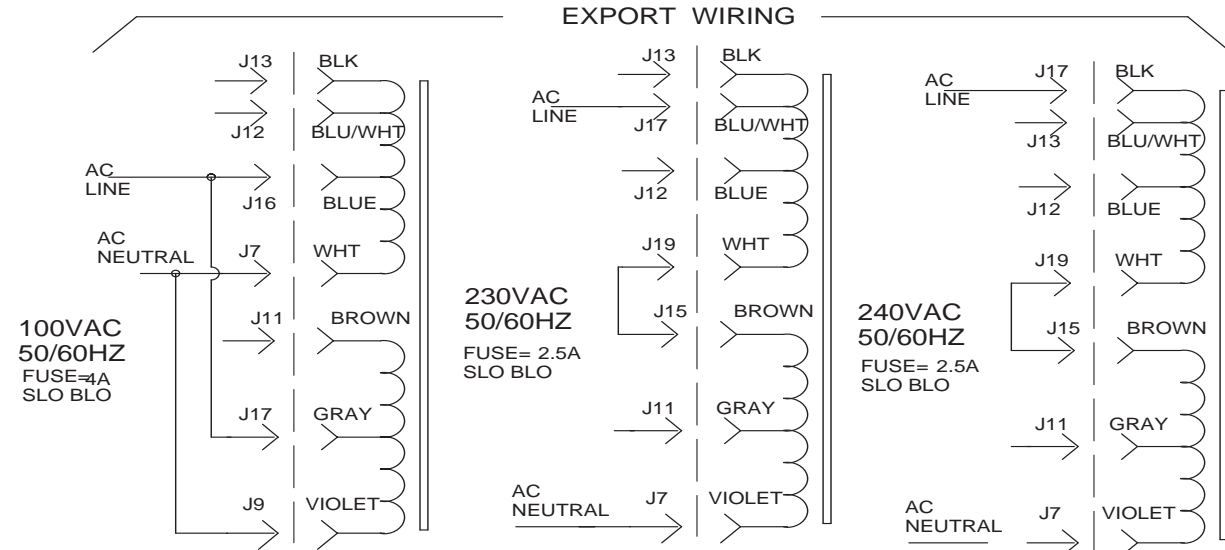

0	03/23/06	CONTROL ISSUE		WFB	
D	2-15-06	ADDED R7	R01852	RLB	
C	2-2-06	CHANGED J14 TO J19 ON WIRING DIAGRAM	R01846	RLB	
B	01/04/06	CHG C55 P/N, DEL DNP NOTES	R01838	WFB	
A	12-29-05	INITIAL ISSUE			

REV	Date	DESCRIPTION	Ecr(s)/Ecn(s)	Chgd By	Appvd by	Date
THE INFORMATION CONTAINED ON THIS DRAWING IS PROPRIETARY TO ST. LOUIS MUSIC, INC.						
Signatures:		Date:		 1901 Congressional, St. Louis, MO 63146		
Drawn: RLB		5-9-05				
Checked:				First Used On:		
Released:						
Plot Date: Thu Mar 23, 2006		Drawing Size: C		Drawing Title: BASS AMP		
Plot Time: 14:45:37		Drawing Type: Schematic		Drawing Number: 07S697		
Tolerance:		Class Code: NONE		Sheet 2 of 3		

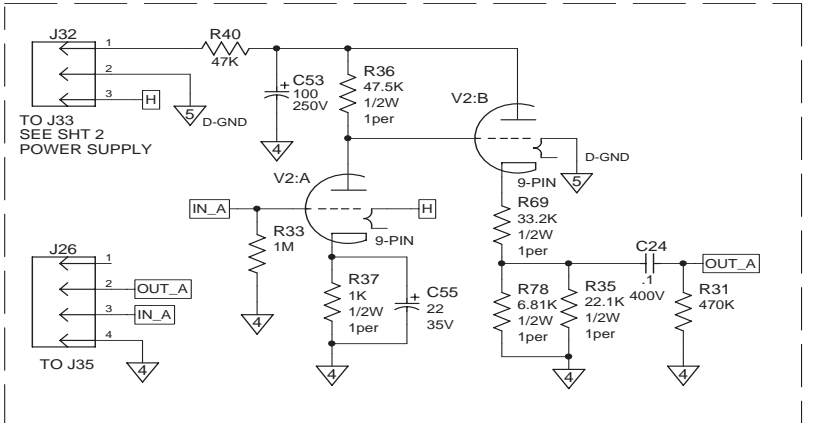
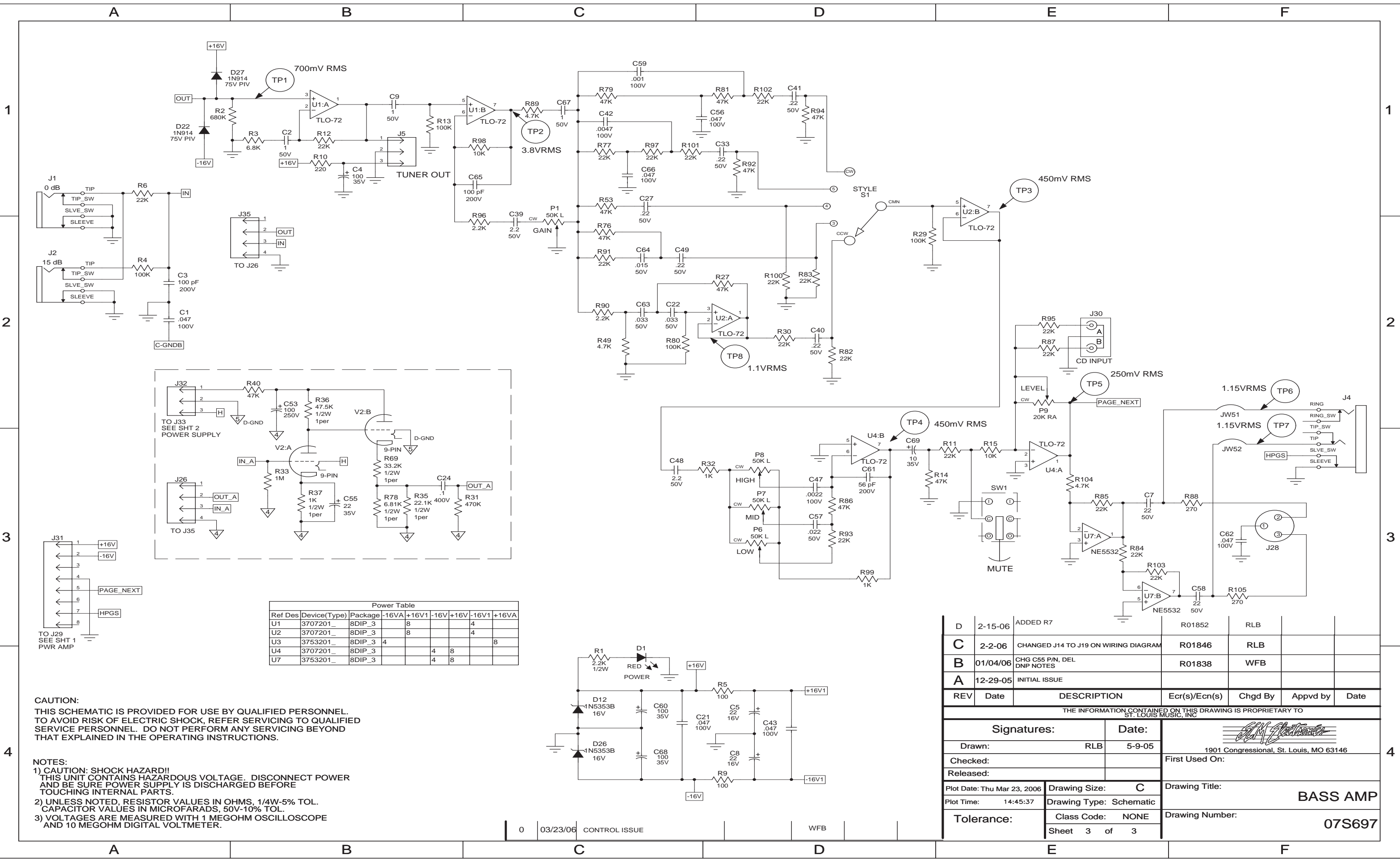

Power Table						
Ref Des	Device(Type)	Package	-16VA	+16V1	-16V	+16V1
U1	3707201_	8DIP_3	8		4	4
U2	3707201_	8DIP_3	8		4	4
U3	3753201_	8DIP_3	4			8
U4	3707201_	8DIP_3		4	8	
U7	3753201_	8DIP_3		4	8	

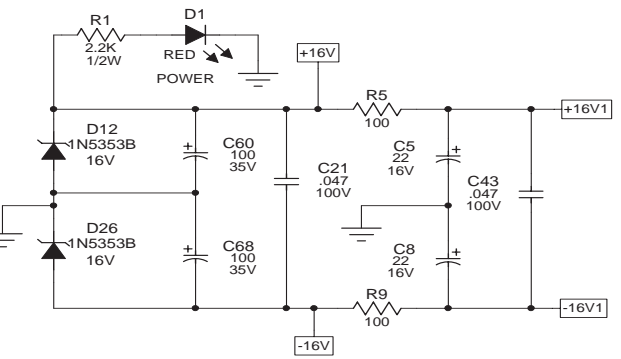

REV	Date	DESCRIPTION	Ecr(s)/Ecn(s)	Chgd By	Appvd by	Date
D	2-15-06	ADDED R7		R01852	RLB	
C	2-2-06	CHANGED J14 TO J19 ON WIRING DIAGRAM		R01846	RLB	
B	01/04/06	CHG C55 P/N, DEL DNP NOTES		R01838	WFB	
A	12-29-05	INITIAL ISSUE				

**CAUTION:**  
THIS SCHEMATIC IS PROVIDED FOR USE BY QUALIFIED PERSONNEL. TO AVOID RISK OF ELECTRIC SHOCK, REFER SERVICING TO QUALIFIED SERVICE PERSONNEL. DO NOT PERFORM ANY SERVICING BEYOND THAT EXPLAINED IN THE OPERATING INSTRUCTIONS.

- NOTES:**
- 1) CAUTION: SHOCK HAZARD!! THIS UNIT CONTAINS HAZARDOUS VOLTAGE. DISCONNECT POWER AND BE SURE POWER SUPPLY IS DISCHARGED BEFORE TOUCHING INTERNAL PARTS.
  - 2) UNLESS NOTED, RESISTOR VALUES IN OHMS, 1/4W-5% TOL. CAPACITOR VALUES IN MICROFARADS, 50V-10% TOL.
  - 3) VOLTAGES ARE MEASURED WITH 1 MEGOHM OSCILLOSCOPE AND 10 MEGOHM DIGITAL VOLTMETER.

THE INFORMATION CONTAINED ON THIS DRAWING IS PROPRIETARY TO ST. LOUIS MUSIC, INC.

Signatures:		Date:
Drawn: RLB		5-9-05
Checked:		1901 Congressional, St. Louis, MO 63146
Released:		First Used On:
Plot Date: Thu Mar 23, 2006	Drawing Size: C	Drawing Title: BASS AMP
Plot Time: 14:45:37	Drawing Type: Schematic	Drawing Number: 07S697
Tolerance:	Class Code: NONE	
	Sheet 3 of 3	

0 03/23/06 CONTROL ISSUE WFB



BA-115HPT

©2007 LOUD Technologies Inc. All rights reserved

Bass Amplifier PCB Schematics

PAGE 3