

This Manual or Schematic is a

FREE DOWNLOAD

For everyone...

From the archives of

Analogrules.com

and

AudioSchematics.com

**If you have paid anything for this
Manual or Schematic**

You have been

RIPPED OFF

**Demand your money back
And let us know who is stealing
our files and charging for
our free downloads**

TABLE OF CONTENTS

| PARAGRAPH NO. | TITLE | PAGE NO. |
|-------------------------------|---------------------------------------------------------|----------|
| SECTION 1 DESCRIPTION | | |
| 1-1 | General | 1-1 |
| 1-2 | Tape Transport Assembly | 1-1 |
| 1-3 | Supply and Takeup Reel Assemblies | 1-1 |
| 1-4 | Capstan Drive Assembly | 1-1 |
| 1-5 | Pinch Roller Assembly | 1-2 |
| 1-6 | Tension Sensor Assembly | 1-2 |
| 1-7 | End-of-Tape Arm and Threading Switch Assembly | 1-3 |
| 1-8 | Tape Lifter Assembly | 1-4 |
| 1-9 | Search-to-Cue/Tape Timer Accessory | 1-4 |
| 1-10 | Transport Control Assembly | 1-5 |
| 1-11 | Motor-Drive Amplifier Assembly | 1-5 |
| 1-12 | Head Assembly | 1-5 |
| 1-13 | Electronics Assembly | 1-6 |
| 1-14 | Control Box Assembly | 1-7 |
| 1-15 | Meter Panel Assembly | 1-7 |
| 1-16 | Power Supply | 1-7 |
| 1-17 | Optional Equipment | 1-11 |
| 1-18 | Specifications | 1-11 |
| SECTION 2 INSTALLATION | | |
| 2-1 | Equipment Siting | 2-1 |
| 2-2 | Unpacking | 2-1 |
| 2-3 | Power Requirements | 2-1 |
| 2-4 | Cable Connections | 2-2 |
| 2-5 | Initial Adjustments | 2-2 |
| 2-6 | Input Signal Setup | 2-2 |
| 2-7 | Balanced Line | 2-3 |
| 2-8 | Unbalanced Line | 2-3 |
| 2-9 | Output Signal Setup | 2-3 |
| 2-10 | Balanced Output | 2-3 |
| 2-11 | Unbalanced Output | 2-3 |
| 2-12 | Sync Transfer Switch | 2-3 |
| 2-13 | Speed Selection | 2-3 |
| 2-14 | Fixed Speed Mode | 2-3 |
| 2-15 | Variable Speed Mode | 2-3 |
| 2-16 | Search-to-Cue and Tape Timer | 2-4 |

TABLE OF CONTENTS (Continued)

| PARAGRAPH NO. | TITLE | PAGE NO. |
|--------------------------------------|------------------------------------------------------|----------|
| SECTION 3 OPERATION | | |
| 3-1 | General | 3-1 |
| 3-2 | Controls and Indicators | 3-1 |
| 3-3 | Speed Selection | 3-1 |
| 3-4 | Fixed Speed Mode | 3-1 |
| 3-5 | Variable Speed Mode | 3-1 |
| 3-6 | Line/Monitor Output Signals | 3-1 |
| 3-7 | Operating Procedures | 3-7 |
| 3-8 | Making a Recording – Without Sel Sync | 3-7 |
| 3-9 | Making a Recording – With Sel Sync | 3-8 |
| 3-10 | Reproducing a Previously Recorded Tape | 3-9 |
| 3-11 | Fast Winding | 3-10 |
| 3-12 | Fast Winding – Search-to-Cue | 3-10 |
| 3-13 | Tape Lifter Defeat | 3-10 |
| SECTION 4 THEORY OF OPERATION | | |
| 4-1 | General | 4-1 |
| 4-2 | Audio Electronics | 4-1 |
| 4-3 | Record | 4-1 |
| 4-4 | Reproduce | 4-2 |
| 4-5 | Individual Channel Audio Switching | 4-5 |
| 4-6 | INPUT/REPRO/S/SYNC Switch Circuit | 4-5 |
| 4-7 | Sync Transfer Switch | 4-6 |
| 4-8 | Audio Mute Function | 4-6 |
| 4-9 | Record Function | 4-6 |
| 4-10 | Master and Standby Monitor Audio Switching | 4-8 |
| 4-11 | STANDBY MONITOR Switch Circuit | 4-9 |
| 4-12 | MASTER MONITOR Switch Circuit | 4-10 |
| 4-13 | LIFT DEFEAT Switch Circuit | 4-10 |
| 4-14 | READY/SAFE Switch Circuit | 4-10 |
| 4-15 | Status Display Circuits | 4-10 |
| 4-16 | TAPE SPEED Switch Circuit | 4-10 |
| 4-17 | MASTER MONITOR Switch Circuit | 4-10 |
| 4-18 | STANDBY MONITOR Switch Circuit | 4-12 |
| 4-19 | INPUT/REPRO/S/SYNC Switch Circuit | 4-12 |
| 4-20 | READY/SAFE Switch Circuit | 4-12 |
| 4-21 | Bias Amp Module | 4-12 |
| 4-22 | Record Amplifier | 4-12 |
| 4-23 | Reproduce Amplifier | 4-13 |

TABLE OF CONTENTS (Continued)

| PARAGRAPH NO. | TITLE | PAGE NO. |
|--------------------------------------------------|------------------------------------------|----------|
| SECTION 4 THEORY OF OPERATION (Continued) | | |
| 4-24 | Transport Control | 4-14 |
| 4-25 | Stop and Braking Logic | 4-14 |
| 4-26 | Initial Turn On | 4-14 |
| 4-27 | Brake Release | 4-16 |
| 4-28 | End-of-Tape (EOT) | 4-16 |
| 4-29 | Record Stop | 4-16 |
| 4-30 | Dynamic Braking | 4-16 |
| 4-31 | Tape Lifter Logic | 4-17 |
| 4-32 | Lift Defeat Logic | 4-17 |
| 4-33 | Play Logic | 4-18 |
| 4-34 | Record Logic | 4-18 |
| 4-35 | Fast Forward Logic | 4-20 |
| 4-36 | Rewind Logic | 4-20 |
| 4-37 | Tape Tension Control and Servo | 4-20 |
| 4-38 | Tension Error Amplifier | 4-20 |
| 4-39 | Play/Record Mode | 4-22 |
| 4-40 | Rewind Mode | 4-22 |
| 4-41 | Fast Forward | 4-22 |
| 4-42 | Stop | 4-24 |
| 4-43 | End-of-Tape | 4-24 |
| 4-44 | Search-to-Cue and Tape Timer | 4-24 |
| 4-45 | Tape Timer | 4-24 |
| 4-46 | Search-to-Cue | 4-26 |
| 4-47 | Reel Motor Drive Amplifiers | 4-28 |
| 4-48 | Capstan Servo | 4-29 |
| 4-49 | Block-Diagram Description | 4-29 |
| 4-50 | Circuit Description | 4-30 |
| 4-51 | Power Supply | 4-33 |
| 4-52 | 39-Vdc Regulator | 4-34 |
| 4-53 | Bias Oscillator | 4-35 |
| 4-54 | 27-Vdc Regulator | 4-35 |
| 4-55 | 15-Vdc Regulator | 4-35 |
| 4-56 | 5-Vdc Regulator | 4-36 |
| SECTION 5 MAINTENANCE | | |
| 5-1 | General | 5-1 |
| 5-2 | Test Equipment | 5-1 |
| 5-3 | Cleaning | 5-2 |

TABLE OF CONTENTS (Continued)

| PARAGRAPH NO. | TITLE | PAGE NO. |
|------------------------------------------|----------------------------------------------------------------|----------|
| SECTION 5 MAINTENANCE (Continued) | | |
| 5-4 | Demagnetization | 5-2 |
| 5-5 | Lubrication | 5-3 |
| 5-6 | Scrape-Flutter Idler Lubrication | 5-3 |
| 5-7 | Maintenance Adjustments | 5-3 |
| 5-8 | Power Supply | 5-3 |
| 5-9 | 39-Volt Regulator Adjustment | 5-3 |
| 5-10 | 15/27-Volt Regulator Adjustment – 27-Volt Section | 5-3 |
| 5-11 | 15/27-Volt Regulator Adjustment – 15-Volt Section | 5-4 |
| 5-12 | Overcurrent Protection Adjustment | 5-4 |
| 5-13 | 5-Volt Regulator Adjustment | 5-5 |
| 5-14 | Motor Drive Amplifier | 5-5 |
| 5-15 | Transport Control | 5-5 |
| 5-16 | Preliminary Setup | 5-5 |
| 5-17 | Tension Sensor Arm Calibration | 5-8 |
| 5-18 | Normalizing Reel Servos | 5-8 |
| 5-19 | Tension Adjustments | 5-8 |
| 5-20 | Capstan Servo System | 5-12 |
| 5-21 | Search-to-Cue/Tape Timer | 5-12 |
| 5-22 | Checkout | 5-12 |
| 5-23 | Adjustment | 5-12 |
| 5-24 | Alignment of Photo-Isolators | 5-13 |
| 5-25 | Mechanical Adjustments | 5-16 |
| 5-26 | Takeup Reel Brake Adjustment | 5-16 |
| 5-27 | Brake Check and Adjustment | 5-16 |
| 5-28 | Brake Solenoid Air Damping | 5-17 |
| 5-29 | Supply Reel Brake Adjustment | 5-17 |
| 5-30 | Capstan Servo Motor | 5-18 |
| 5-31 | Tape Lifter Assembly Adjustments | 5-18 |
| 5-32 | Tape Lifter Solenoid Air Damping | 5-19 |
| 5-33 | Head Assembly | 5-19 |
| 5-34 | Pinch Roller | 5-20 |
| 5-35 | Check | 5-20 |
| 5-36 | Adjustment | 5-21 |
| 5-37 | End-of-Tape Arm | 5-21 |

TABLE OF CONTENTS (Continued)

| PARAGRAPH NO. | TITLE | PAGE NO. |
|------------------------------------------|-----------------------------------------------------|----------|
| SECTION 5 MAINTENANCE (Continued) | | |
| 5-38 | Audio Adjustments | 5-23 |
| 5-39 | 7-1/2-In/S Reproduce Alignment | 5-23 |
| 5-40 | 7-1/2 - 15 In/S Record Alignment | 5-26 |
| 5-41 | 15-30 In/S Reproduce Alignment | 5-29 |
| 5-42 | 15-30 In/S Record Alignment | 5-30 |
| 5-43 | Distortion Measurement | 5-33 |
| 5-44 | Noise and Erasure Depth | 5-33 |
| 5-45 | Bias Amp Module Alignment | 5-34 |
| 5-46 | Troubleshooting | 5-35 |
| 5-47 | Possible Corrective Actions | 5-35 |
| 5-48 | Causes of Tape Speed Error | 5-35 |
| 5-49 | Causes of Noise | 5-35 |
| 5-50 | Causes of Distortion | 5-36 |
| 5-51 | Causes of Flutter | 5-36 |
| 5-52 | Flutter Troubleshooting Hints | 5-36 |
| 5-53 | Transport Control | 5-36 |
| 5-54 | Audio Switching | 5-38 |
| 5-55 | Audio Signal | 5-38 |
| 5-56 | Reproduce Amplifier | 5-38 |
| 5-57 | Record Amplifier | 5-38 |
| 5-58 | Bias Amp Module | 5-38 |
| 5-59 | Power Supply | 5-38 |
| 5-60 | Removal and Replacement | 5-39 |
| 5-61 | Control Box Assembly | 5-39 |
| 5-62 | Disassembly | 5-39 |
| 5-63 | Toggle Switch Removal and Replacement | 5-39 |
| 5-64 | Pushbutton Switch Removal and Replacement | 5-41 |
| 5-65 | LED Removal and Replacement | 5-42 |
| 5-66 | Reassembly | 5-42 |
| 5-67 | Reel Motors | 5-42 |
| 5-68 | Capstan Motor | 5-44 |
| 5-69 | Head Assembly | 5-44 |
| 5-70 | Tension Sensor | 5-46 |
| 5-71 | Pinch Roller Assembly | 5-46 |
| 5-72 | End-of-Tape Arm and Tape Threading Switch | 5-47 |
| 5-73 | Search-to-Cue and Tape Timer Assembly | 5-48 |
| 5-74 | Tape Lifter Assembly | 5-48 |
| 5-75 | Power Supply | 5-49 |
| 5-76 | Motor Drive Amplifier Assembly | 5-49 |
| 5-77 | Meter Panel Assembly | 5-50 |

TABLE OF CONTENTS (Continued)

| TITLE | PAGE NO. |
|---------------------------------------------------|----------|
| SECTION 6 PARTS LISTS AND SCHEMATICS | |
| Indented List of Assemblies | 6-ii |
| Numerical List of Assemblies | 6-vi |
| Numerical List of Schematics | 6-ix |
| APPENDIX A | |
| Integrated Circuits | A-1 |
| APPENDIX B | |
| Transport Control PWA 4050706 Alignment | B-1 |

LIST OF ILLUSTRATIONS

| FIGURE NO. | TITLE | PAGE NO. |
|------------|----------------------------------------------------------------|----------|
| 1-1 | Location of Components (Front) | 1-2 |
| 1-2 | Location of Components (Rear) | 1-3 |
| 1-3 | Tape Transport Assembly | 1-4 |
| 1-4 | Transport Control Assembly | 1-5 |
| 1-5 | Motor-Drive Amplifier Assembly | 1-6 |
| 1-6 | Head Assembly (Typical) | 1-7 |
| 1-7 | Electronics Assembly (Typical) | 1-8 |
| 1-8 | Control Box Assembly | 1-8 |
| 1-9 | Meter Panel Assembly | 1-10 |
| 1-10 | Power Supply | 1-11 |
| | | |
| 2-1 | Input/Output Connector Panel | 2-2 |
| 2-2 | Input/Output Cable Wiring | 2-2 |
| 2-3 | Capstan Servo PWA | 2-4 |
| 2-4 | Search-to-Cue and Tape Timer PWA | 2-5 |
| | | |
| 3-1 | Tape Threading Path | 3-8 |
| 3-2 | Head Usage for Different Operating Modes | 3-9 |
| | | |
| 4-1 | MM-1200 Block Diagram | 4-2 |
| 4-2 | Record Signal Path Partial Schematic | 4-3 |
| 4-3 | S/Sync and Repro Signal Path Partial Schematic | 4-4 |
| 4-4 | Audio Control Partial Schematic | 4-7 |
| 4-5 | Divider Voltages with Neutral Control Signal (REPRO) | 4-8 |
| 4-6 | Divider Voltages with +27V Control Signal (S/SYNC) | 4-8 |
| 4-7 | Divider Voltages with Ground Control Signal (INPUT) | 4-8 |
| 4-8 | Control Panel Simplified Schematic, Channel 1 Shown | 4-11 |
| 4-9 | Stop and Braking Logic Partial Schematic | 4-15 |
| 4-10 | Play and Record Logic Partial Schematic | 4-19 |
| 4-11 | Fast Forward and Rewind Logic | 4-21 |
| 4-12 | Tension Servo Circuits Partial Schematic | 4-23 |
| 4-13 | Tape Timer Block Diagram | 4-25 |
| 4-14 | Search-to-Cue Block Diagram | 4-27 |
| 4-15 | Reel Motor Drive Amplifier Simplified Schematic | 4-29 |
| 4-16 | Capstan Servo Block Diagram | 4-30 |
| 4-17 | Capstan Phase Comparator, Typical Waveform | 4-32 |
| 4-18 | Power Supply Block Diagram | 4-33 |
| | | |
| 5-1 | Power Supply Test Points and Adjustments | 5-4 |
| 5-2 | MDA PWA Test Point Location | 5-6 |

LIST OF ILLUSTRATIONS Continued)

| FIGURE NO. | TITLE | PAGE NO. |
|------------|-----------------------------------------------------------------------------------------------------|----------|
| 5-3 | Transport Control PWA, Control Locations | 5-7 |
| 5-4 | Tension Sensor Arm Calibration | 5-9 |
| 5-5 | Tape Tension Adjustments | 5-9 |
| 5-6 | Positioning Tension Sensor Arm | 5-11 |
| 5-7 | Servo PWA Test Points and Adjustments | 5-13 |
| 5-8 | Waveform at TP2 on Servo PWA | 5-13 |
| 5-9 | Tachometer Preamplifier Adjustment | 5-15 |
| 5-10 | Tachometer Preamplifier Adjustment Waveforms With Tape Moving in the Forward Direction | 5-15 |
| 5-11 | Transport Adjustment Points | 5-16 |
| 5-12 | Servo Motor Maintenance | 5-19 |
| 5-13 | Tape Lifter Adjustment | 5-20 |
| 5-14 | Pinch Roller Adjustment | 5-21 |
| 5-15 | End-of-Tape Arm | 5-22 |
| 5-16 | Tension Arm Dashpot Assembly | 5-23 |
| 5-17 | End-of-Tape Arm and Threading Switch Adjustment | 5-24 |
| 5-18 | 30-Hz to 18-kHz Band Limiting Filter | 5-26 |
| 5-19 | ASA 'A' Weighted Filter | 5-34 |
| 5-20 | Control Box Case Removal | 5-40 |
| 5-21 | Control Box Assembly | 5-40 |
| 5-22 | Switch PWA Disassembly | 5-41 |
| 5-23 | Switch Replacement | 5-41 |
| 5-24 | Transport Disassembly (Top) | 5-43 |
| 5-25 | Transport Disassembly (Bottom) | 5-45 |

LIST OF TABLES

| TABLE | TITLE | PAGE NO. |
|-------|----------------------------------------------------------------------------|----------|
| 1-1 | Optional Equipment | 1-9 |
| 1-2 | Specifications | 1-11 |
| 2-1 | Power Supply Strapping | 2-1 |
| 2-2 | Speed Strapping | 2-3 |
| 2-3 | Tape Speeds for Various Input Frequencies | 2-4 |
| 3-1 | Control Box Assembly – Controls and Indicators | 3-2 |
| 3-2 | Search-to-Cue and Tape Timer Controls and Indicators | 3-5 |
| 3-3 | Electronics Assemblies – Operator Controls for a Typical Channel | 3-5 |
| 3-4 | Line Output/Monitor Signals | 3-6 |
| 4-1 | Audio Switching Bus Levels | 4-9 |
| 4-2 | High-Frequency Equalization Components | 4-13 |
| 5-1 | Test Equipment and Maintenance Materials | 5-1 |
| 5-2 | Transport Brake Torques | 5-17 |
| 5-3 | Electronics Assembly – Alignment Adjustments | 5-25 |
| 5-4 | Ampex Alignment Test Tapes | 5-26 |
| 5-5 | Rotational Rates (Revolutions/Second) | 5-36 |
| 5-6 | Troubleshooting Hints – Transport System | 5-37 |
| 5-7 | Troubleshooting Hints – Audio Switching System | 5-38 |
| 5-8 | Troubleshooting Hints – Power Supply | 5-39 |

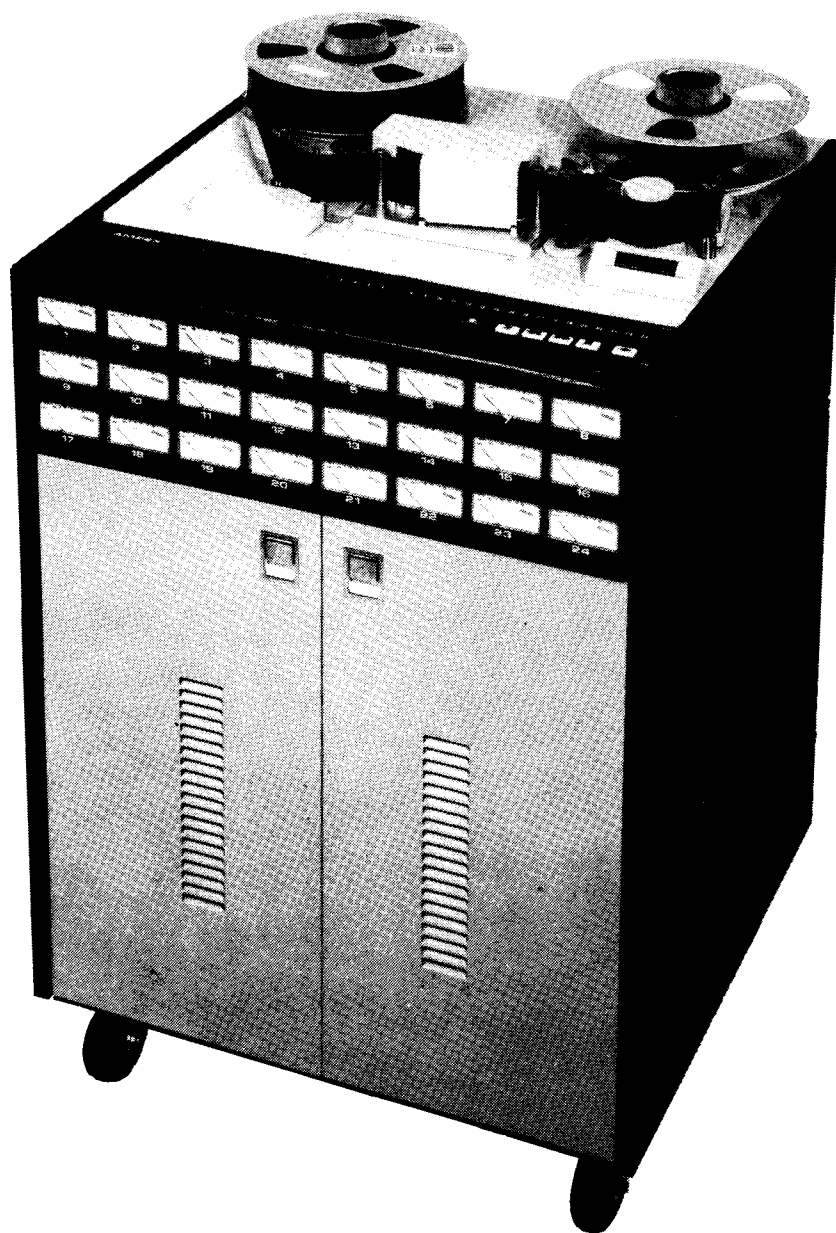

13550-1

MM-1200 Multichannel Recorder/Reproducer

SECTION 1

DESCRIPTION

1-1. GENERAL

This manual, Catalog No. 4890400, provides installation instructions, operation instructions, maintenance and troubleshooting instructions, and theory of operation for the Ampex MM-1200 Multichannel Recorder/Reproducer, Part No. 4010240, versions -13 through -24.

The Ampex MM-1200 Multichannel Recorder/Reproducer provides up to 24 channels of audio recording/reproducing capability using one-inch or two-inch audio recording tape. The 8-channel version uses one-inch tape and the 16- and 24-channel versions use two-inch tape. The machine is capable of operating in any of three speeds; i.e., 7-1/2 in/s, 15 in/s and 30 in/s. When the associated PWA is properly strapped, any two adjacent speeds are front-panel selectable by means of a high/low speed switch. NAB and IEC (CCIR) equalization capabilities are also provided.

The MM-1200 provides the capability of recording on one or more channels simultaneously while monitoring one or more previously recorded channels. A Sel Sync* (Selective Synchronization) feature permits monitoring a previously recorded channel while recording in synchronization on one or more channels. This feature is enabled by using the record head of that previously recorded channel in a playback mode while one or more record heads are in the record mode.

The MM-1200 Recorder/Reproducer, shown in the frontispiece, consists of a tape transport assembly, a transport control assembly, a frame assembly, a motor-drive amplifier assembly, a head assembly, audio electronics assemblies, a control box assembly, a power supply assembly, a meter panel

assembly, an accessory panel, and an input/output panel assembly. Multi-pin connectors are used extensively between units to facilitate removal and replacement of various components and assemblies. Location of the various components and assemblies are shown in Figures 1-1 and 1-2.

1-2. TAPE TRANSPORT ASSEMBLY

The tape transport assembly (Figure 1-3) consists of a supply reel assembly, a takeup reel assembly, a capstan drive assembly, a pinch roller assembly, a tension sensor assembly, an end-of-tape sensor and tape threading switch assembly, a tape lifter assembly, and a search-to-cue/tape timer assembly. Also mounted on, but not considered part of, the tape transport assembly is the head assembly consisting of erase, record and reproduce heads, and a scrape-flutter idler, mounted in a housing. All of the above components of the tape transport assembly are discussed in the following paragraphs.

1-3. Supply and Takeup Reel Assemblies

The supply and takeup reel assemblies each consist of a split-phase, four-pole ac torque motor and a mechanical brake. These motors drive the tape reel turntables. The brake assemblies are spring-loaded and solenoid-actuated, and are adjustable for correct braking tension. The reel assemblies are removable through the top of the transport deck plate for servicing.

1-4. Capstan Drive Assembly

The capstan drive assembly consists of a dc servo controlled motor with an internal tachometer assembly. The extended shaft of the motor is the capstan for the tape transport. The tachometer assembly consists of a pickup coil and inner and

*Ampex Trademark

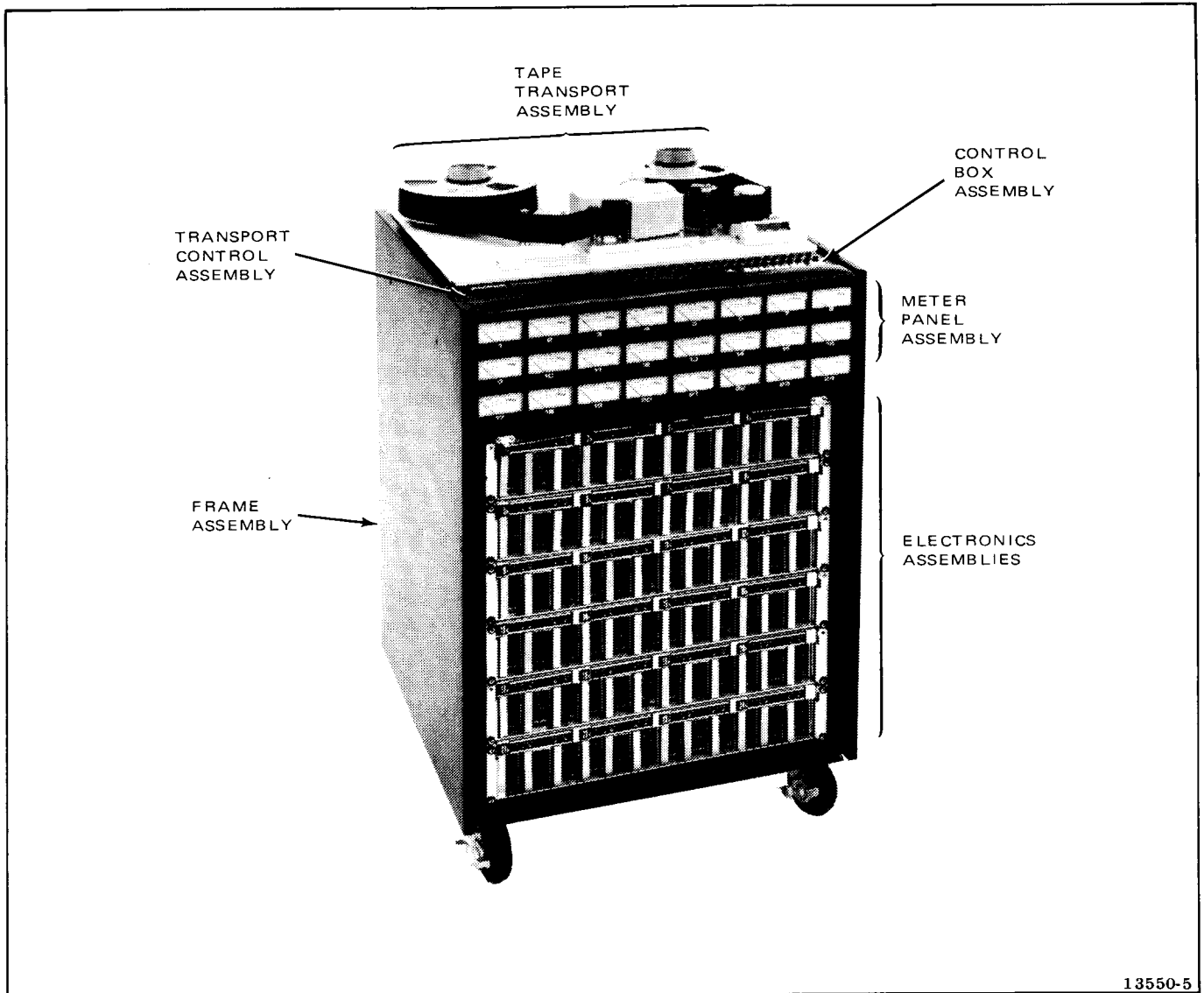

13550-5

Figure 1-1. Location of Components (Front)

outer tachometer wheels mounted on the motor shaft and housing. The use of inner and outer tachometer wheels minimizes flutter in the tachometer output signal.

1-5. Pinch Roller Assembly

The pinch roller assembly consists of a solenoid-operated, shaft-mounted arm on which is mounted a rubber pinch roller. The pinch roller is fitted with ball bearings at each end of the roller shaft. An adjustable pressure spring is used to maintain the correct force of the pinch roller against the capstan.

1-6. Tension Sensor Assembly

The tension sensor assembly, adjacent to the supply reel assembly, consists of two photovoltaic cells and an incandescent lamp mounted on a fixed bracket. The three active components are wired to a connector plug that interconnects with the transport harness. A movable window attached to the sensor arm in the tape path passes an amount of light, proportional to the amount of tape tension, from the lamp to the photovoltaic cells. This signal is used by the motor-drive amplifiers to maintain correct tape tension.

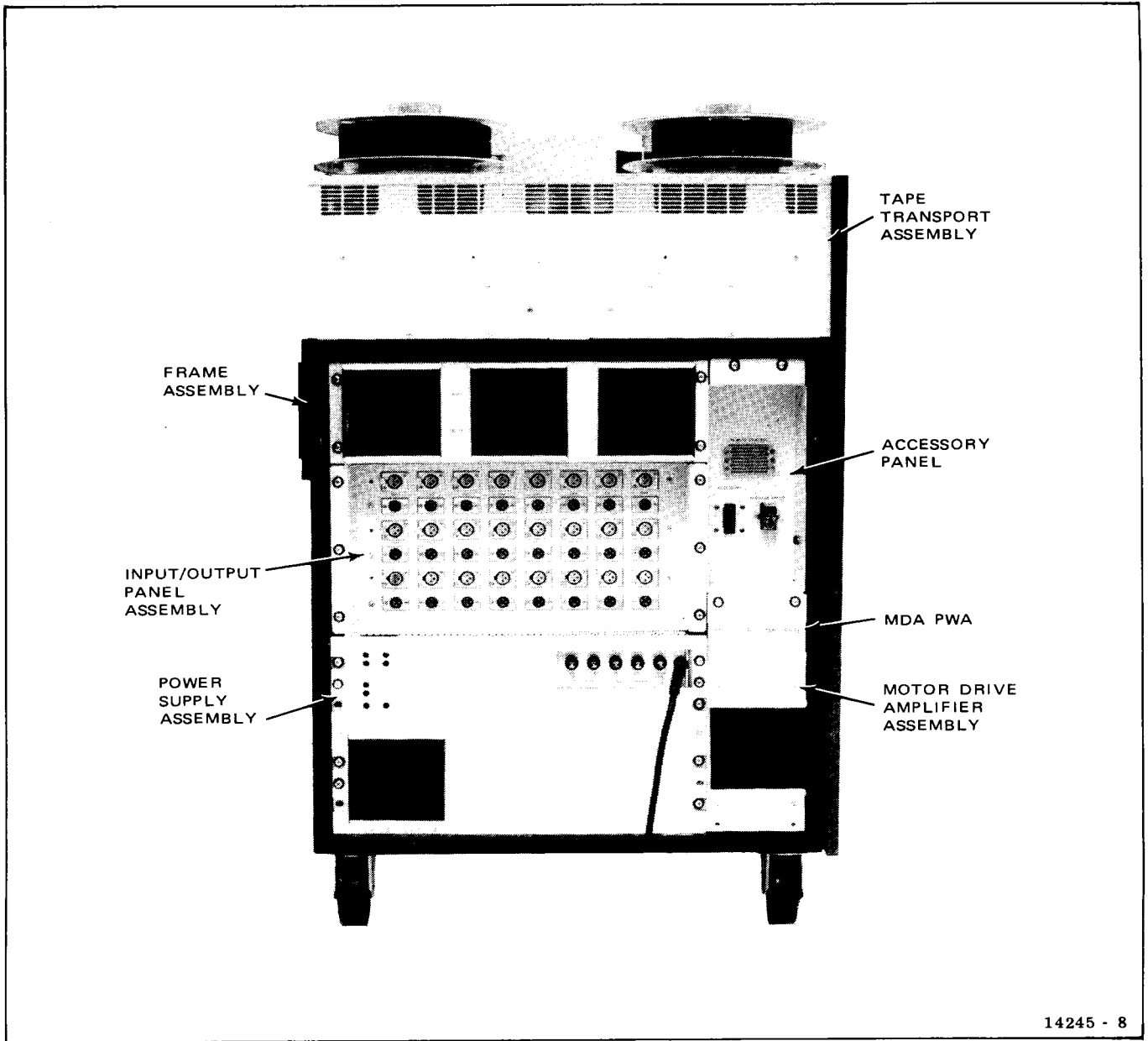

14245 - 8

Figure 1-2. Location of Components (Rear)

1-7 End-of-Tape Arm and Threading Switch Assembly

The end-of-tape arm and threading switch assembly, adjacent to the takeup reel, is contained in a housing and consists of a spring-loaded tension arm fitted with a tape guide at the free end. The

post to which the tension arm is attached extends through the transport chassis and is mechanically coupled to a dashpot assembly to damp the motion of the spring-loaded arm. The end-of-tape arm is equipped with an actuator that activates a switch when there is no tape pressure against the arm, thereby signaling end-of-tape and applying the reel motor brakes.

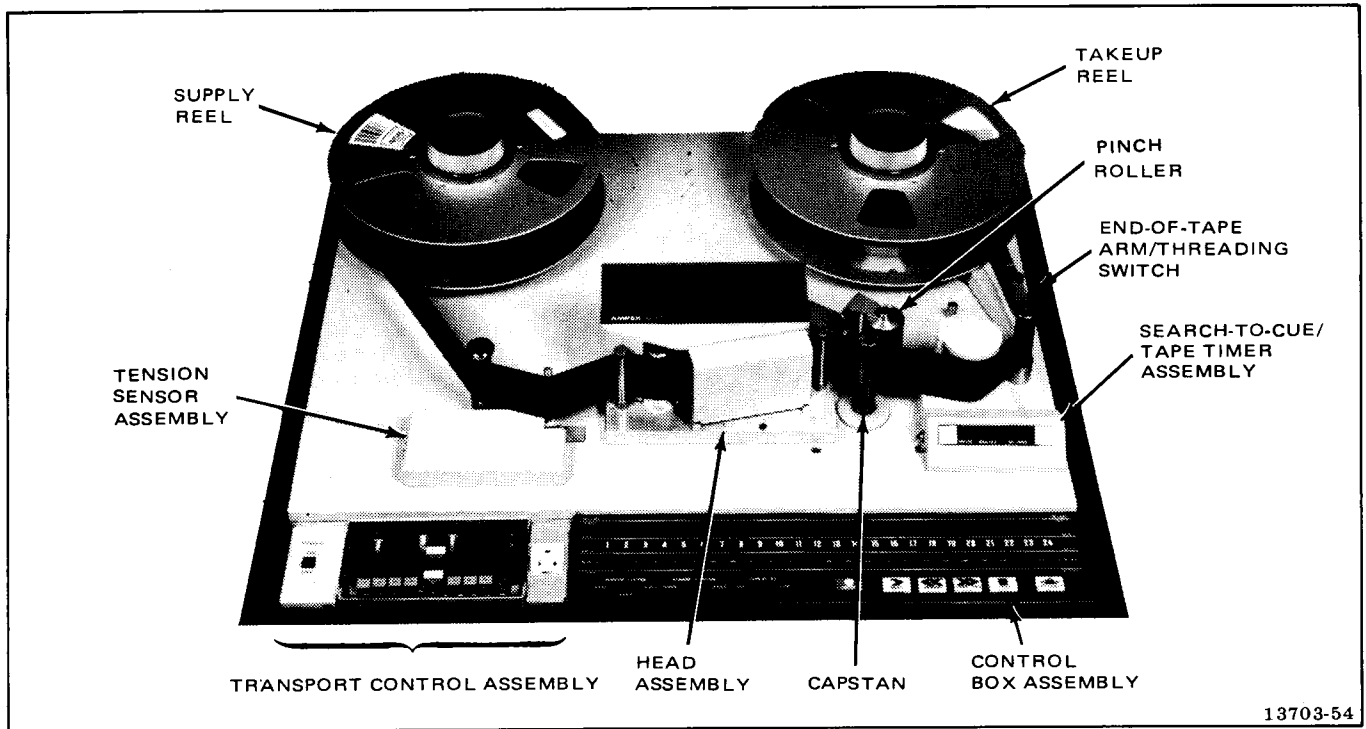

Figure 1-3. Tape Transport Assembly

The end-of-tape arm may also be moved to the full counterclockwise position, which activates another switch that performs the same function as the end-of-tape switch, i.e., applies the reel motor brakes. The end-of-tape arm is held in the threading position by a magnetic catch mechanism beneath the transport chassis.

1-8. Tape Lifter Assembly

The tape lifter assembly is a solenoid-operated, spring-return, pivoted assembly. The tape lifter pins extend upward through the head assembly and are moved outward of the head assembly automatically during the fast wind modes of transport operation, thereby lifting the tape away from the heads. The lifter operation can be defeated by the operator during the fast wind modes of operation for cueing purposes. The lifters can also be operator-activated while the transport is in the standby mode and in the play and record modes of operation.

1-9. Search-to-Cue/Tape Timer Accessory

The tape timer consists of a tape-driven idler attached to a mounting housing. The timer idler roller drives a disc that has alternate opaque and transparent segments. As this disc rotates, caused by tape motion, it interrupts light sources that are focused on a pair of photosensitive diodes. The diodes trigger an electronic counter as the light sources are interrupted by the moving disc, and the counter and its associated decoder translate the elapsed time into increments of + (plus) or - (minus) hours, minutes, and seconds. The counter will count up or down according to the tape direction and will indicate the tape position in terms of elapsed time, regardless of speed. The direction from zero is indicated by a + or - symbol at the left of the hours display. The counter also has an output that sends a motion-sense signal to the transport control assembly when the tape is in motion. The search-to-cue feature is controlled by a part of the tape timer and will permit exact return to any predetermined point on the tape, regardless of the direction of tape travel.

1-10. Transport Control Assembly

The transport control assembly (Figure 1-4) is in an enclosed chassis having a lift-up cover and containing three separate printed wiring assemblies, the main power switch, and the ac utility outlet accessory. The three PWAs contain the transport control electronics, the capstan servo electronics, and the search-to-cue/tape timer electronics. Each of the PWAs plugs into a 56-pin connector receptacle which is hardwired to the connector cable that interconnects with the tape transport assembly, the search-to-cue/tape timer assembly, the remote control connector, the local control box assembly, the capstan tachometer, and the electronics assembly. The transport control chassis is mounted at the rear of the meter panel adjacent to the control box assembly.

1-11. Motor-Drive Amplifier Assembly

The motor-drive amplifier (MDA) assembly consists of a printed wiring assembly and two heat-sinks, each with three power transistors, all contained in a common housing. The printed wiring assembly contains the preamplifiers for each of the reel motors. Four of the transistors on two of the heatsinks are the drive transistors for each of the two reel motors. The remaining two transistors are the drive transistors for the capstan motor. The MDA is connected by means of a multi-pin

connector to the main transport control harness of the MM-1200. There is sufficient slack in the wiring harness such that the entire MDA assembly may be removed for servicing. Figure 1-5 shows the MDA assembly and the MDA printed wiring assembly.

1-12. HEAD ASSEMBLY

Eight-track, 16-track, and 24-track head assemblies are available for use with the MM-1200 in the standard configuration. The 8-track head assembly utilizes one-inch-wide recording tape; and the 16-track and the 24-track head assemblies utilize two-inch tape. Each head assembly contains three headstack assemblies; i.e., the record head, the erase head, and the reproduce head. The head assembly also contains one scrape-flutter idler with a provision for another optional scrape-flutter idler. The record and reproduce head stacks are magnetically shielded with laminated mu-metal. A hinged head shield assembly is mounted in front of the record and reproduce heads. In addition, a precision tape guide is mounted adjacent to the erase head at one end of the assembly, and another is mounted adjacent to the reproduce head at the other end. The record heads are identical to the reproduce heads and, at 15 and 30 in/s, provide Sel-Sync response comparable to that of conventional reproduce heads. Figure 1-6 shows a typical head assembly.

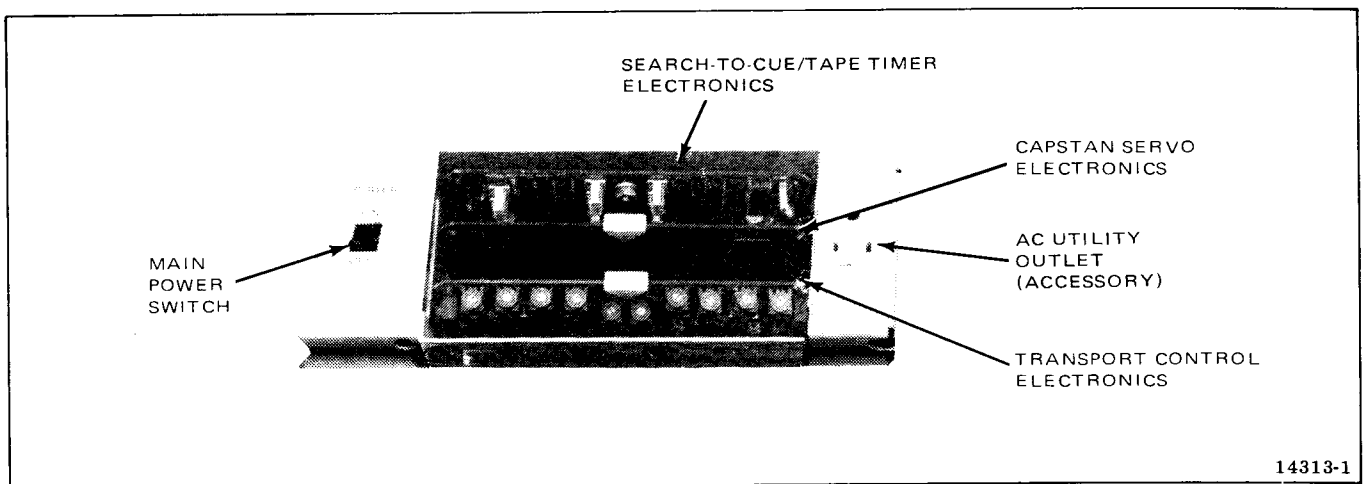

Figure 1-4. Transport Control Assembly

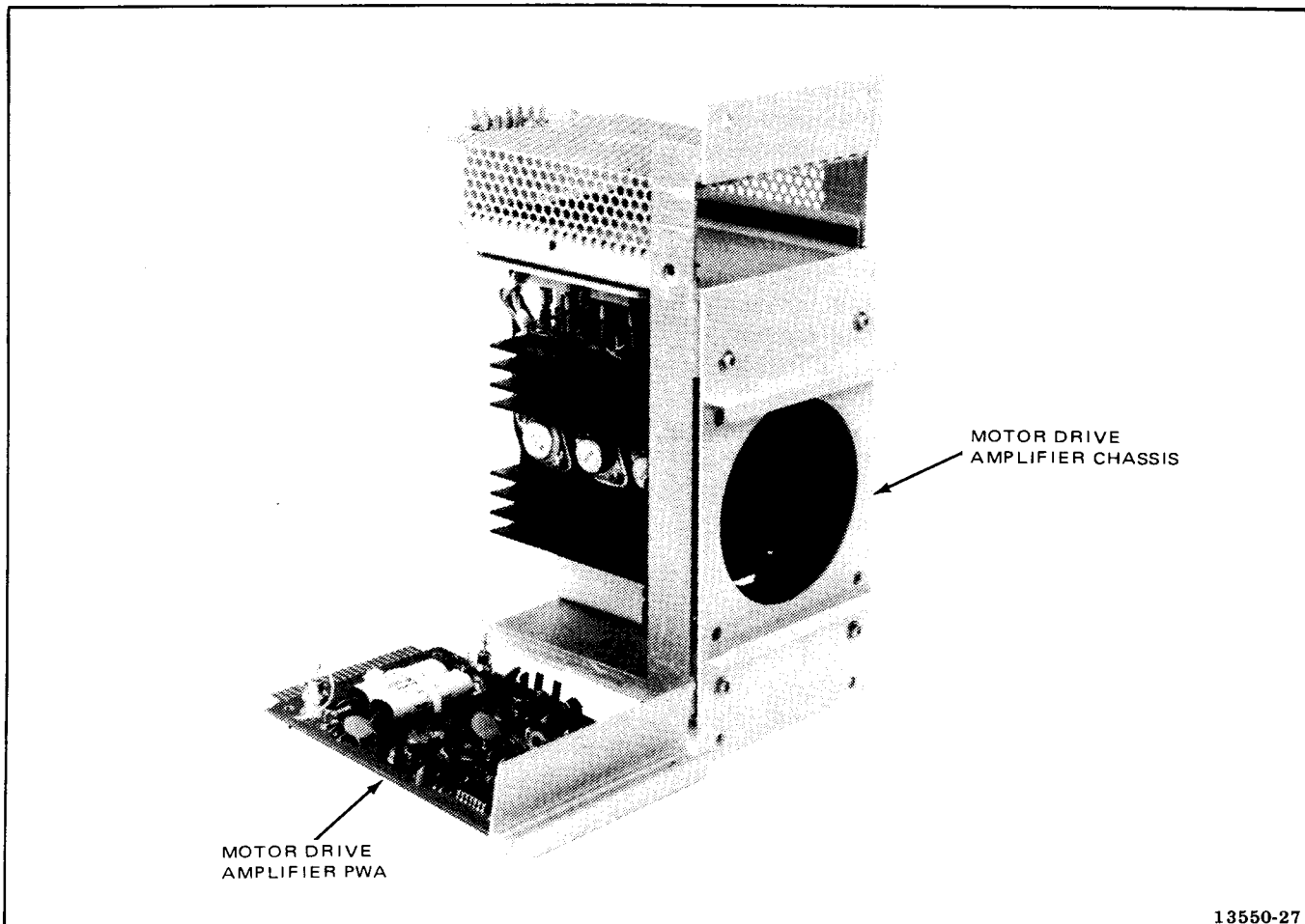

Figure 1-5. Motor-Drive Amplifier Assembly

1-13. ELECTRONICS ASSEMBLY

Each electronics assembly contains four separate groups of electronic printed wiring assemblies. Each group forms one record/reproduce channel and consists of an audio switcher module, a bias amp module, a record amplifier, and a reproduce amplifier. Each of these units plugs into a motherboard at the rear of the electronics assembly and is removable from the front of the assembly. Extender boards may be used to extend any of the units for servicing. All electronics maintenance controls (except the reproduce bias trap) and some of the operator controls are contained on the removable units. The bias trap components are mounted on the motherboard adjacent to the reproduce amplifier connector socket and are accessible with the record amplifier removed.

Each group of units; i.e., audio switcher, reproduce amplifier, record amplifier, and bias amp module, is associated with one audio channel. Therefore, if the MM-1200 has an 8-track capability, two complete electronic assemblies are required. Four electronic assemblies would be required for a 16-track capability, and six electronic assemblies for a 24-track capability. Figure 1-7 shows a typical electronics assembly. Each record and reproduce amplifier has a 10-pin receptacle that accommodates a plug-in equalization PWA. The plug-in equalization PWAs are at right angles to the amplifier PWAs so that the equalization adjustment controls are accessible from the front of the electronics assembly. Each electronics assembly includes a fuse at the rear of the assembly which protects the 39-volt supply. Each audio channel has a removable line-bridging

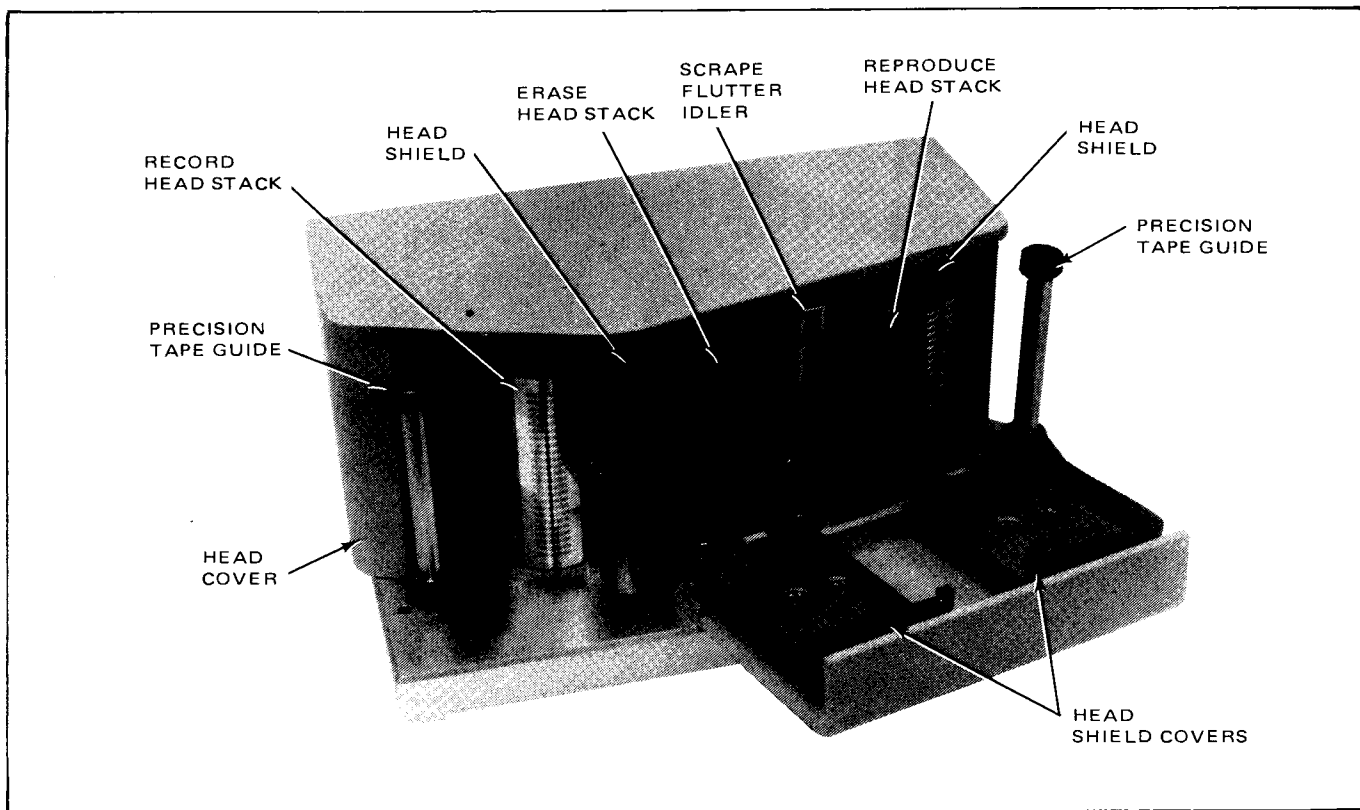

Figure 1-6. Head Assembly (Typical)

transformer in an accessory socket on the rear panel of the electronics assembly. The line-bridging transformer accessory may be removed and others substituted, depending on the matching requirements for the external interfacing equipment.

1-14. CONTROL BOX ASSEMBLY

The control box assembly (Figure 1-8) is a removable assembly that doubles as a remote control unit when used with an optional extension cable (see Table 1-1. A dummy control box is provided in the miscellaneous parts kit for use when the control box is removed for remote application).

The control box assembly contains the controls and indicators necessary for all operating functions of the MM-1200 Recorder/Reproducer, with the exception of four audio controls located on the electronics assembly. The transport control switches are all of the illuminated pushbutton type, except

the TAPE SPEED switch, which is a two-position toggle. Depressing any pushbutton switch, except RECORD and LIFT DEFEAT, cancels any pushbutton switch previously selected. The RECORD pushbutton switch has no effect unless it is pressed concurrently with the PLAY pushbutton switch to make a recording. The tape transport assembly may be changed from any mode of operation to any other mode of operation without depressing the STOP pushbutton switch first.

There are two rows of toggle switches which are used to control the record and reproduce functions for each channel of audio. LEDs mounted beneath the control box assembly surface illuminate through translucent windows to indicate the status of each audio channel.

1-15. METER PANEL ASSEMBLY

The meter panel assembly contains an illuminated meter for each channel of audio. The panel may be

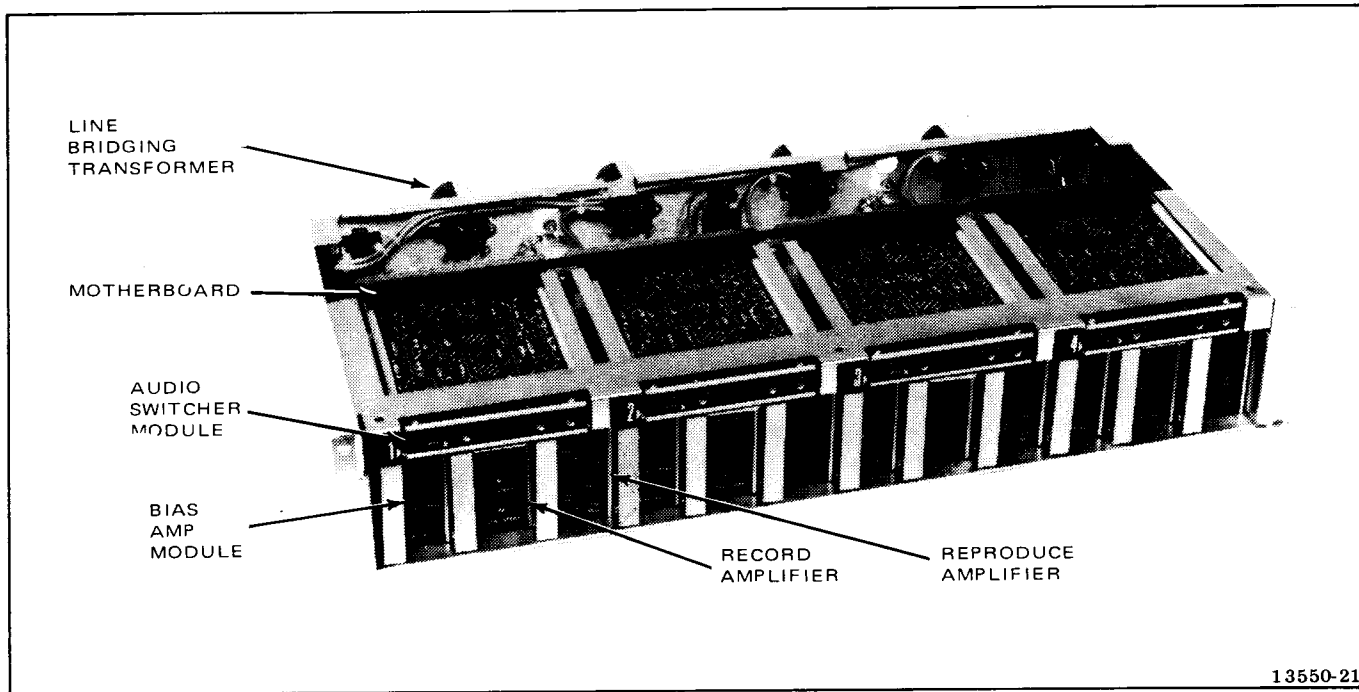

Figure 1-7. Electronics Assembly (Typical)

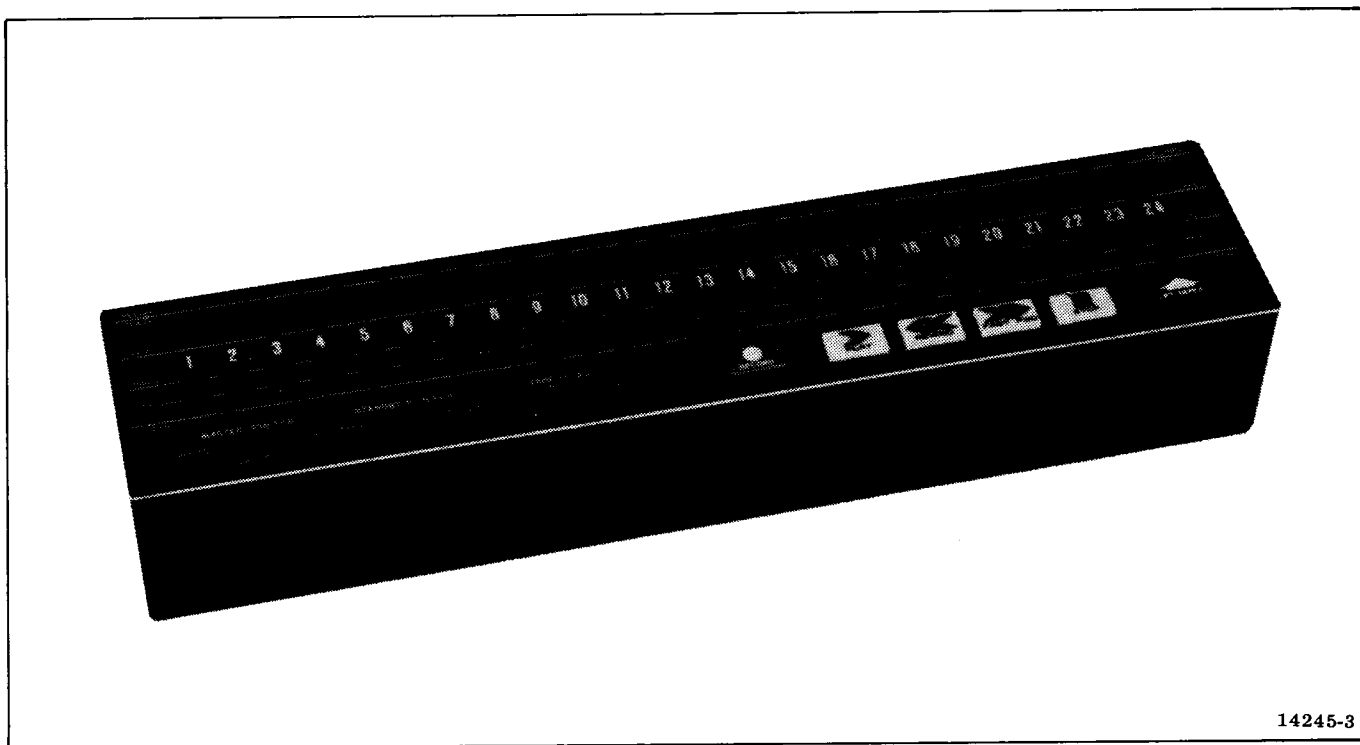

Figure 1-8. Control Box Assembly

tilted upward or centered vertically for the most convenient viewing angle. A cable harness provides interconnection with the electronics assembly. Figure 1-9 shows a typical meter panel assembly.

1-16. POWER SUPPLY

The power supply is contained in a single chassis and is mounted at the lower rear of the frame assembly adjacent to the MDA assembly. The power supply contains a heavy duty power transformer; two printed wiring assemblies; two heat-sinks, one having two power transistors mounted on it, the other having two power transistors and a 5-volt regulator IC; and the necessary rectifiers and filter capacitors. The PWAs and their associated power transistors provide +39-volt, +27-volt, and +15-volt power for the transport assembly, electronics assemblies, and the bias oscillator. The 5-volt regulator mounted on the heatsink provides power to the search-to-cue/tape

timer assembly. The bias oscillator, which is a part of the +39-volt regulator PWA, provides bias current to all the bias amp modules. The 39V and the 15/27V PWAs are removable for service and can be used with extender cards for maintenance purposes. Figure 1-10 shows the power supply.

1-17. OPTIONAL EQUIPMENT

Table 1-1 lists the optional equipment available for use with the MM-1200 and the application for each item.

1-18. SPECIFICATIONS

Specifications for the MM-1200 Recorder/Reproducer are presented in Table 1-2.

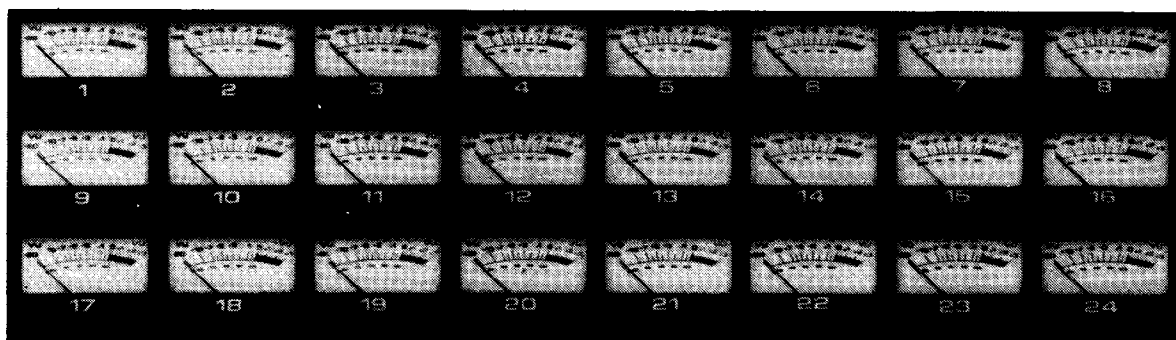

13550-8

Figure 1-9. Meter Panel Assembly

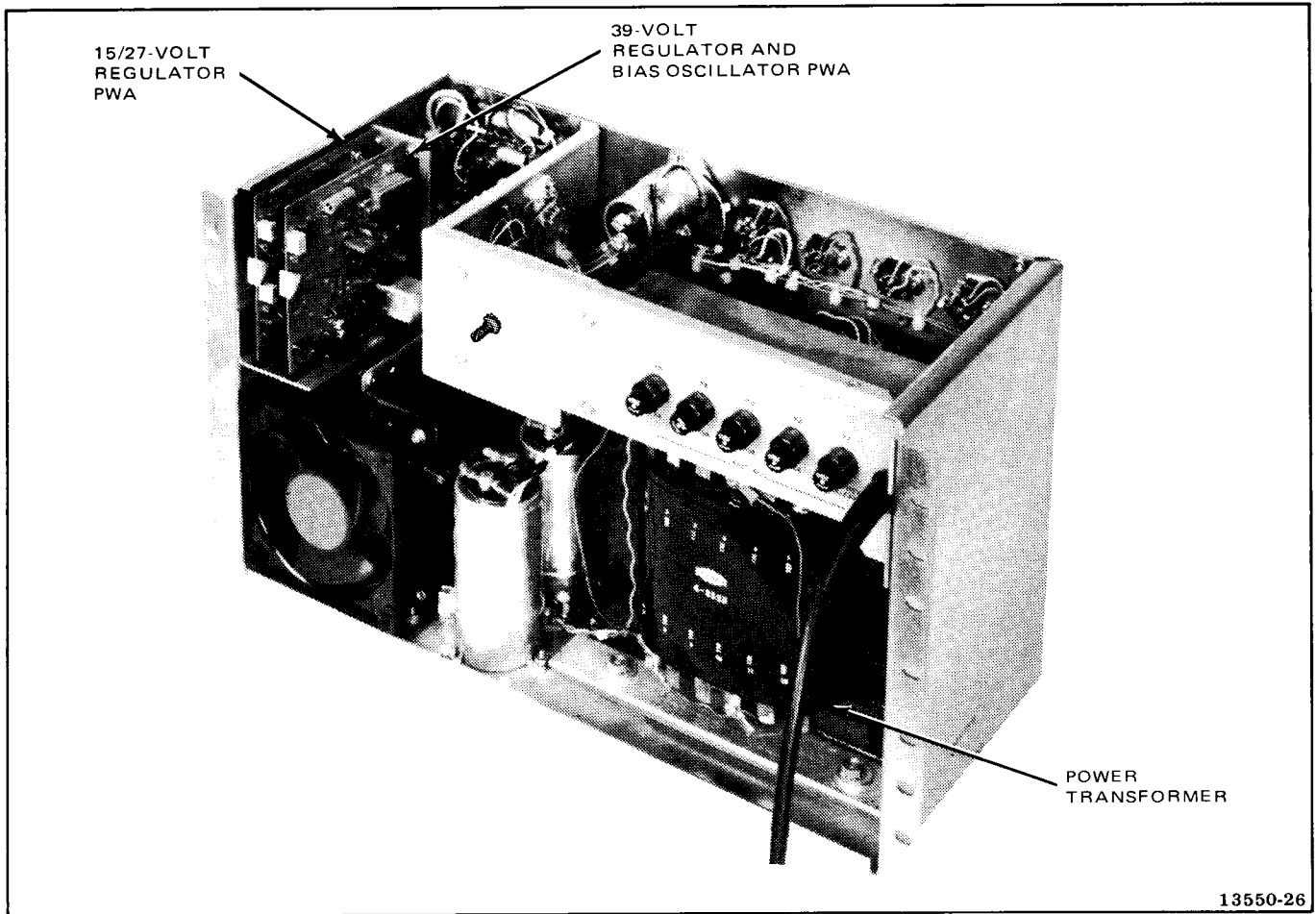

Figure 1-10. Power Supply

Table 1-1. Optional Equipment

| ITEM | PART NO. | USE |
|--------------------------------|---------------|--------------------------------------------------------|
| 2-Inch/1-Inch Conversion Kit | 4850154 | Converts from 2-inch to 1-inch capability. |
| Fixed Guide, 1-Inch/2-Inch | 4210353-01/02 | Auxiliary 1- or 2-inch guide. |
| 8-Track Head Assembly | 4020334 | Converts from 16-track to 8-track capability. |
| 16-Track Head Assembly | 4020372 | Converts from 24-track to 16-track capability. |
| 8/16-Track Conversion Kit | 4010246 | Converts to 16-track capability. |
| 16/24-Track Conversion Kit | 4010247 | Converts to 24-track capability. |
| Remote Cable Assembly | 4952348-02 | Provides remote capability for control box assembly. |
| Brake Quiet Kit | 4010268 | Provides air-damped brake solenoids. |
| Tape Lifter Solenoid Kit | 4010280 | Provides air-damped tape lifter solenoid. |
| Transport Control Box Assembly | 4020411-01 | Provides remote capability for transport control only. |

Table 1-1. Optional Equipment (Continued)

| ITEM | PART NO. | USE |
|----------------------------------------------|------------------|---------------------------------------------------------------------------------------|
| AC Outlet Assembly | 4050789-02 | Provides ac power to auxiliary equipment. |
| Sync Lock Accessory | 4020391-09 | Synchronizes tape speed to film or videotape speed. |
| Variable Speed Oscillator Accessory | 4010217-05/06 | Varies operating speed for sync, effects, etc. |
| Time Code Synchronizer Accessory | | |
| <i>Consists of:</i> | | |
| BE450 Wide-Range Synchronizer | 4990235 | Slaves audio recorder to video recorder of second audio recorder. |
| BE420 Edit Code Reader | 4010187 | Reads SMPTE code from source recorder. |
| BE520 Edit Code Generator | 4010166-01 | Generates SMPTE time and control code to be recorded on tape. |
| BE460 Dual-Cue Controller | 4010169-01 | Enables automatic search-to-cue for master and slave recorders simultaneously. |
| Video Layback Head Accessory | 4010233-03 | Permits recording of audio track on videotape. |
| Auditec MK II Accessory | 4010241-01 | Provides interface to permit use of MM-1200 with RA-4000 Automatic Programmer. |
| PURC Accessory | 4010236-07 | Provides pickup recording capability. |
| Wide-Band Preamplifier Accessory | 4050739-02 | Permits time-code synchronization at shuttle speeds. |
| Search-to-Cue/Timer Remote Display Accessory | 4020410-02 | Provides remote control of search-to-cue function and timer display. |
| Transformer | 4580200-02 | Permits use of 600-ohm balanced line. |
| Overhead Bridge Assembly | 4010242-02 | Permits mounting of accessory equipment such as Auditec, Sync-Lock, and Synchronizer. |
| 2-Inch Tape Splicer Accessory | 4010249-01 | Facilitates tape splicing. |
| Spares Kit 'A' | 1385849-01/02 | Spare major assemblies for MM-1200. |
| Spares Kit 'B' | 1385850-01/02/03 | Spare component parts for MM-1200. |
| Brush Replacement Kit | 4030414 | Replacement brushes for capstan motor. |
| Extender Board PWA | 4020151-04 | Extends Reproduce PWA. |
| Extender Board PWA | 4020152-02 | Extends Record PWA. |
| Extender Board PWA | 4020153-04 | Extends Bias Amp PWA. |
| Extender Board PWA | 4020154-02 | Extends Power Supply PWA. |
| Extender Board PWA | 4050803-01 | Extends Audio Switcher PWA. |
| Extender Board PWA | 4050801-01 | Extends MDA PWA. |
| Erase Head Shield (24-Track) | 4600163 | Protects the head wiring. |

Table 1-2. Specifications

| |
|---------------------------------------------------------------------------------------------------------------------------------------------------------------------------------------------------------------------------------------------------------------------------------------------------------------------------------------------------------|
| <p>Tape Widths:</p> <p>1-inch for 8-track systems. 2-inch for 16- or 24-track systems.</p> <p>Tape Speeds:</p> <p>7-1/2 in/s (19.05 cm/s), 15 in/s (38.1 cm/s), or 30 in/s (76.2 cm/s).</p> <p>Reel Size:</p> <p>7-inch to 16-inch reel diameters with NAB hubs. (Specifications apply up to 14-inch reel diameters only.)</p> |
|---------------------------------------------------------------------------------------------------------------------------------------------------------------------------------------------------------------------------------------------------------------------------------------------------------------------------------------------------------|

Table 1-2. Specifications (Continued)

Inputs:

20 kilohms balanced input. Accepts line levels from -17 dBm to produce recommended operating levels.

Outputs:

600-ohm load balanced or unbalanced with nominal output level of +4 dBm and maximum output of +27 dBm, nominal. Clip level +28 dBm.

Equalization:

Automatically switched with speed change within speed pairs (7-1/2 - 15 or 15 - 30 in/s) using NAB or IEC (CCIR) plug-in equalizer circuit.

Electronics:

All electronics are solid state. Printed circuit plug-in boards for record, reproduce, and bias/erase amplifiers, equalization, and audio switcher.

Power Supply:

39 Vdc regulated (audio-signal system) +27 Vdc, +15 Vdc and +5 Vdc regulated (servo and control system and timer).

Electronic Overload Margin:

Record Amplifier – Overload greater than 28 dB above normal operating level.

Overall Frequency Response, Sel-Sync and Reproduce Modes:

| | |
|-------------|---------------------------------------------------------------|
| 7-1/2 in/s: | ±2 dB from 40 Hz to 15 kHz (not applicable to Sel-Sync mode). |
| 15 in/s: | ±2 dB from 30 Hz to 15 kHz. |
| 30 in/s: | ±2 dB from 50 Hz to 18 kHz. |

Signal-to-Noise Ratio:

| | |
|-------------------------------------------------------------|-----------------------------------------------------------------------------------------------------------------------------------------------------------------------------------------------------------------------|
| Using Ampex 456 tape or equivalent at 7-1/2, 15 or 30 in/s: | 8 or 16 channel; 64 dB; 24 channel, 59 dB; peak record level to unweighted (30 Hz to 18 kHz) noise; includes bias, erase, and reproduce amplifier noise. (Peak record level corresponds to a tape flux of 520 nWb/m.) |
|-------------------------------------------------------------|-----------------------------------------------------------------------------------------------------------------------------------------------------------------------------------------------------------------------|

| | |
|-------------------------------------------------------------|-----------------------------------------------------------------------------------------------------------------------------------------------------------------------------------------------------------------------|
| Using Ampex 406 tape or equivalent at 7-1/2, 15 or 30 in/s: | 8 or 16 channel, 63 dB; 24 channel, 58 dB; peak record level to unweighted (30 Hz to 18 kHz) noise; includes bias, erase, and reproduce amplifier noise. (Peak record level corresponds to a tape flux of 520 nWb/m.) |
|-------------------------------------------------------------|-----------------------------------------------------------------------------------------------------------------------------------------------------------------------------------------------------------------------|

Third Harmonic Distortion:

| | |
|-------------------------------------|---------------------------------------------------|
| 7-1/2, 15, or 30 in/s (1000 Hz) | |
| Using Ampex 456 tape or equivalent: | <1.0% at recorded flux level 3 dB above 260 nWb/m |
| Using Ampex 406 tape or equivalent: | <1.0% at recorded flux level of 260 nWb/m |

Even Order Harmonic Distortion:

At 1000 Hz, ≤0.3% at a recorded level corresponding to 3 dB above a tape flux of 260 nWb/m.

Bias/Erase Frequency:

150 kHz ±2%

Table 1-2. Specifications (Continued)

Erase Depth (using Ampex 406 tape or equivalent):

At 1000 Hz, peak record level signal erased to -75 dB minimum on channel(s) selected.

Flutter:

In a bandwidth 0.5 to 200 Hz, while reproducing a 3,150 Hz signal.

DIN 45507 or ANSI S4.3 **NAB**

| | Weighted | Unweighted | Weighted | Unweighted |
|------------|----------|------------|----------|------------|
| 7-1/2 in/s | 0.10 | 0.15 | 0.06 | 0.13 |
| 15/30 in/s | 0.08 | 0.10 | 0.04 | 0.08 |

Crosstalk:

-50 dB minimum for 8 or 16 channels at 500 Hz.

-45 dB minimum for 24 channels at 500 Hz.

Timing Accuracy:

±0.1% (1.8 seconds in a 30-minute record time) for tape recorded, rewound, and reproduced on the same unit.

Electronic Tape Timer:

Tape driven. Reads up to ±1 hour, 59 minutes, 59 seconds at any play speed.

Search-to-Cue:

Bidirectional. Searches either direction to a preset cue point.

Tape Speed Accuracy:

Within ±0.05% from beginning to end of reel (per NAB Standard on Magnetic Recording and Reproduction, 1965, Section 2.02.01).

Capstan Reference Oscillator:

±0.01%, crystal controlled.

Heads:

8-, 16-, and 24-track tape stacks are non-adjustable precision-mounted.

Start Time:

Rated speed within 1.0 second at 30 in/s speed.

Rated speed within 0.5 second at 7-1/2 or 15 in/s speed.

Rewind Time:

2.0 minutes for 10-1/2-inch reel of 1.5-mil tape.

Table 1-2. Specifications (Continued)

Power Requirements:

105 to 250 Vac, $\pm 10\%$, 50/60 Hz:

| | | |
|----------------------|-----------------|-----------------------|
| MM-1200, 8-Channel: | 0.8 kVA maximum | } without accessories |
| MM-1200, 16-Channel: | 1.0 kVA maximum | |
| MM-1200, 24-Channel: | 1.2 kVA maximum | |

Size:

8-, 16-, and 24-track units without overhead bridge:

| | |
|--------|-----------------|
| Width | 29 in. (74 cm) |
| Depth | 27 in. (69 cm) |
| Height | 45 in. (114 cm) |

Weight:

| | |
|----------|-----------------|
| 8-Track | 415 lb (188 kg) |
| 16-Track | 465 lb (210 kg) |
| 24-Track | 530 lb (240 kg) |

SECTION 2 INSTALLATION

2-1. EQUIPMENT SITING

The location of the MM-1200 should be free of strong magnetic and electrostatic fields which could interfere with or degrade system operation. The environment should be relatively dust free, ambient temperature should be from +32 to +122°F (0 to 50°C), and relative humidity should be from 10 to 90%. There should be no less than 6 inches of ventilation space at the rear and sides of the MM-1200 which will also allow clearance for maximum size reels and, if installed, the overhead bridge.

2-2. UNPACKING

Upon receipt, examine the shipping crate for any signs of damage. Unpack and inspect the equipment for physical damage. Check the packing list to determine that all items have been received. Immediately report any damages (retain the shipping container) or storages to the Ampex representative and the transportation company. Remove all materials (adhesive tape, rubber bands, etc.) used to secure tape handling and other moving components during shipment. Remove and inspect each record and reproduce amplifier and check that the equalizer plug-in PWAs have not become dislodged during shipment. Check that the audio switcher and the bias amp module PWAs have not become dislodged during shipment.

2-3. POWER REQUIREMENTS

The MM-1200 requires 115/220 volts at 50/60 Hz (nominal). Power is connected by a grounding type (three-prong) plug.

WARNING

ENSURE THAT THE POWER PLUG IS PROPERLY GROUNDED BY MEANS OF THE CENTER PRONG.

Determine the line input voltage and strap the power transformer according to Table 2-1 to accommodate the input line voltage. Access to the power transformer is obtained by removing the power supply cover panel. See *Power Supply, Removal and Replacement* procedures, paragraph 5-75.

Table 2-1. Power Supply Strapping

| | | TRANSFORMER TERMINALS | | | | | | | | | | | |
|-------|-----|-----------------------|-----------|-----------|-----------|-----------|-----------|-----------|-----------|-----------|-----------|-----------|-----------|
| | | 1 | 2 | 3 | 4 | 5 | 6 | 7 | 8 | 9 | 10 | 11 | 12 |
| VOLTS | 106 | OR | RD/ YL | | | | | OR/ BN | YL | | | | |
| | 110 | OR | | RD/ YL | | | | OR/ BN | | YL | | | |
| | 115 | OR | | | RD/ YL | | | OR/ BN | | | YL | | |
| | 120 | OR | | | | RD/ YL | | OR/ BN | | | | YL | |
| | 127 | OR | | | | | RD/ YL | OR/ BN | | | | | YL |
| | 210 | OR/ YL | RD | | | | | BN | OR/ YL | | | | |
| | 215 | OR/ YL | RD | | | | | BN | | OR/ YL | | | |
| | 220 | OR/ YL | | RD | | | | BN | OR/ YL | | | | |
| | 225 | OR/ YL | | RD | | | | BN | | | OR/ YL | | |
| | 230 | OR/ YL | | | RD | | | BN | | | OR/ YL | | |
| | 235 | OR/ YL | | | RD | | | BN | | | | OR/ YL | |
| | 240 | OR/ YL | | | | RD | | BN | | | | OR/ YL | |
| | 247 | OR/ YL | | | | RD | | BN | | | | | OR/ YL |
| | 254 | OR/ YL | | | | | RD | BN | | | | | OR/ YL |

| | | |
|-------|--------------|--------------|
| WIRES | | |
| BROWN | } | ORANGE |
| RED | | YELLOW |
| | HARNES WIRES | JUMPER WIRES |

2.4. CABLE CONNECTIONS

Audio signals are connected to and from the MM-1200 by rear panel connectors shown in Figure 2-1. The connectors are three-conductor XLR type. Female connectors are used for the input signals and male connectors are used for the output signals. The mating plugs are user-supplied, XLR type, and should be used with shielded-pair audio cable to provide input and output connections. Wire the mating plugs as shown in Figure 2-2 according to the required usage.

2.5. INITIAL ADJUSTMENTS

2-6. Input Signal Setup

The MM-1200 Recorder/Reproducer is provided with a line-bridging transformer for each channel. Four of these line-bridging transformers are mounted on the rear of each electronics assembly. These transformers provide a 20-kilohm balanced input to each record amplifier. An accessory input transformer, Ampex Part No. 4580200-02, can be used in place of the line-bridging transformer if a 600-ohm balanced input impedance is desired.

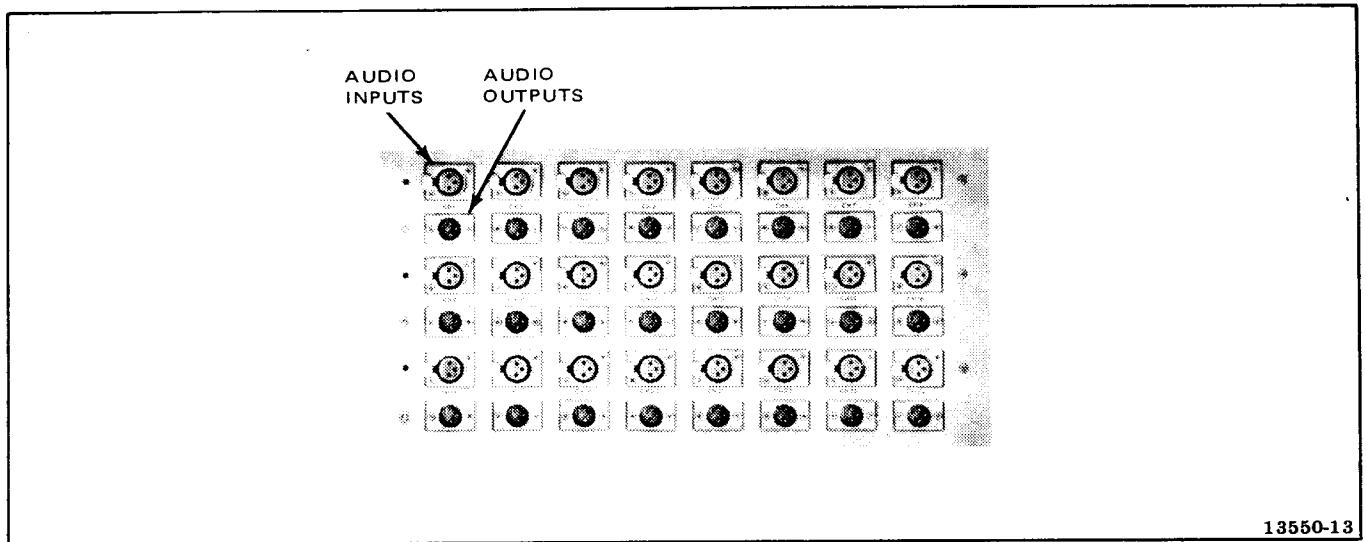

Figure 2-1. Input/Output Connector Panel

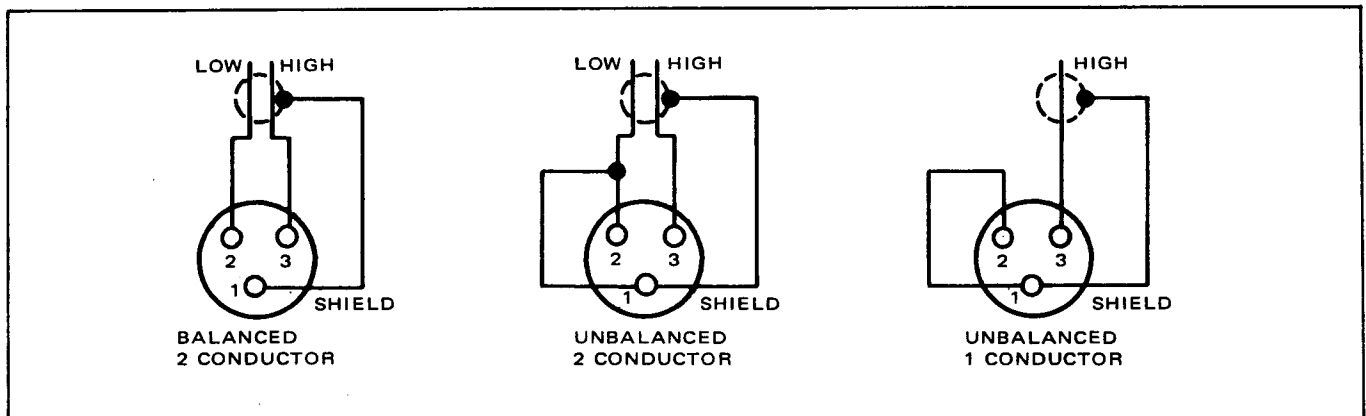

Figure 2-2. Input/Output Cable Wiring

2-7. Balanced Line. Prepare the recorder/reproducer for balanced line inputs as follows:

1. Ensure that the correct input transformer is installed in the transformer socket at the rear of the electronics assembly for each record/reproduce channel in use.
2. Connect the male connector of the two-conductor shielded cable to the input connector of each channel in use.

2-8. Unbalanced Line. Prepare the recorder/reproducer for unbalanced line inputs as follows:

1. Ensure that the unbalanced line input male connector has been prepared as in Figure 2-2.
2. Connect the male connector of the unbalanced line input cable to the input connector for each channel in use.

2-9. Output Signal Setup

The MM-1200 Recorder/Reproducer is supplied with a 600-ohm matching transformer at the output of each reproduce amplifier. The output may be used in a balanced or an unbalanced configuration according to the method of wiring the external output cable.

2-10. Balanced Output. Wire the external output cable as shown in Figure 2-2 for the balanced configuration, and connect the cable connector at the output connector for each channel of use.

2-11. Unbalanced Output. Wire the external output cable connector as shown in Figure 2-2 for the appropriate unbalanced configuration, and connect the cable connector to the output connector for each channel of use.

2-12. Sync Transfer Switch

Remove the LIFT DEFEAT or the STOP button lens (see Tables 3-1, 3-4) to gain access, and select the desired position of the SYNC TRANSFER switch for the installation. The REPRO position (away from the transport) selects the record head as the monitor source (Sel Sync monitor function) for all channels set to S/SYNC. The INPUT

position (toward the transport) selects the record input as the monitor source for all channels selected to S/SYNC.

2-13. Speed Selection

2-14. Fixed Speed Mode. Any two adjacent operational speeds may be preset for control panel selection by positioning internal jumpers on the capstan servo PWA (Figure 2-3). Strap the speed pair as follows:

1. On the transport control chassis, set the POWER switch to OFF.
2. Position the jumpers on the capstan servo PWA as shown in Table 2-2.

Table 2-2. Speed Strapping

| 30/15 IN/S | 15/17-1/2 IN/S |
|------------|----------------|
| E5 to E3 | E5 to E4 |
| E2 to E4 | E2 to E1 |

4. Replace the capstan servo PWA into the transport control chassis.
5. Reposition the search-to-cue/tape timer speed strapping, if necessary, as shown in paragraph 2-16.

2-15. Variable Speed Mode. With the dummy plug, Ampex Part No. 4050710-01, inserted into the VARIABLE SPEED socket (located on the accessory panel), the capstan operates at fixed speeds selected by the operator. To operate the MM-1200 at variable speeds, remove the dummy plug from the VARIABLE SPEED socket, adjust the speed strapping to the desired nominal speed range as described above, and connect either variable frequency source described below.

- a. Ampex VS-10 Variable Speed Oscillator: Connect the VS-10 to the VARIABLE SPEED socket. The speed of the MM-1200 can then be controlled following the instruction manual, Catalog No. 4890351, which accompanies the VS-10 Oscillator accessory.

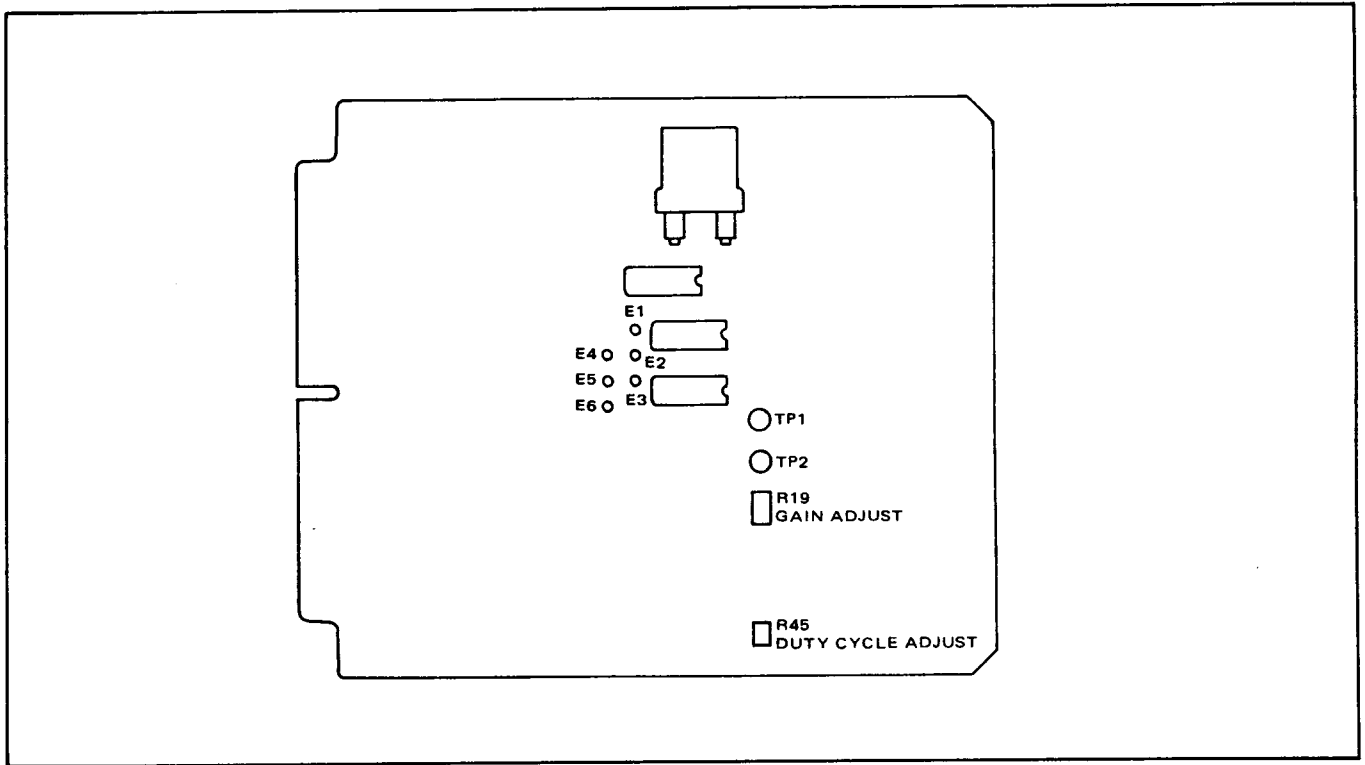

Figure 2-3. Capstan Servo PWA

b. Audio Frequency Sine/Square Wave Generator:

Any sine/square wave source between 3 and 30 volts rms may be used. The generator output must be connected to pins 2 (high) and 3 (ground) of a connector suitable for interfacing with the VARIABLE SPEED connector. Table 2-3 shows generator frequencies which will produce specific tape speeds.

Table 2-3. Tape Speeds for Various Input Frequencies

| TAPE SPEED | INPUT FREQUENCY (Hz) |
|------------|----------------------|
| 1/4 speed | 2400 |
| 1/2 speed | 4800 |
| Normal* | 9600 |

*Normal speed is determined by the setting of the TAPE SPEED switch on the control box and the speed straps on the capstan servo PWA.

2-16. Search-to-Cue and Tape Timer

Depressing the DISPLAY RESET pushbutton on the tape timer assembly will reset the counter display to zero.

On the search-to-cue and tape timer PWA (Figure 2-4), position the speed straps as follows:

1. Remove power from the recorder/reproducer and remove the search-to-cue and tape timer PWA from the transport control chassis.
2. Position the LO strap between LO and 7-1/2 or 15, and the HI strap between HI and 15 or 30, as required, to match the speeds selected previously on the capstan servo PWA.
3. Reinstall the search-to-cue and tape timer PWA into the transport control chassis.

The search-to-cue electronics has been optimized at the factory for use with 10-1/2-inch reels. If

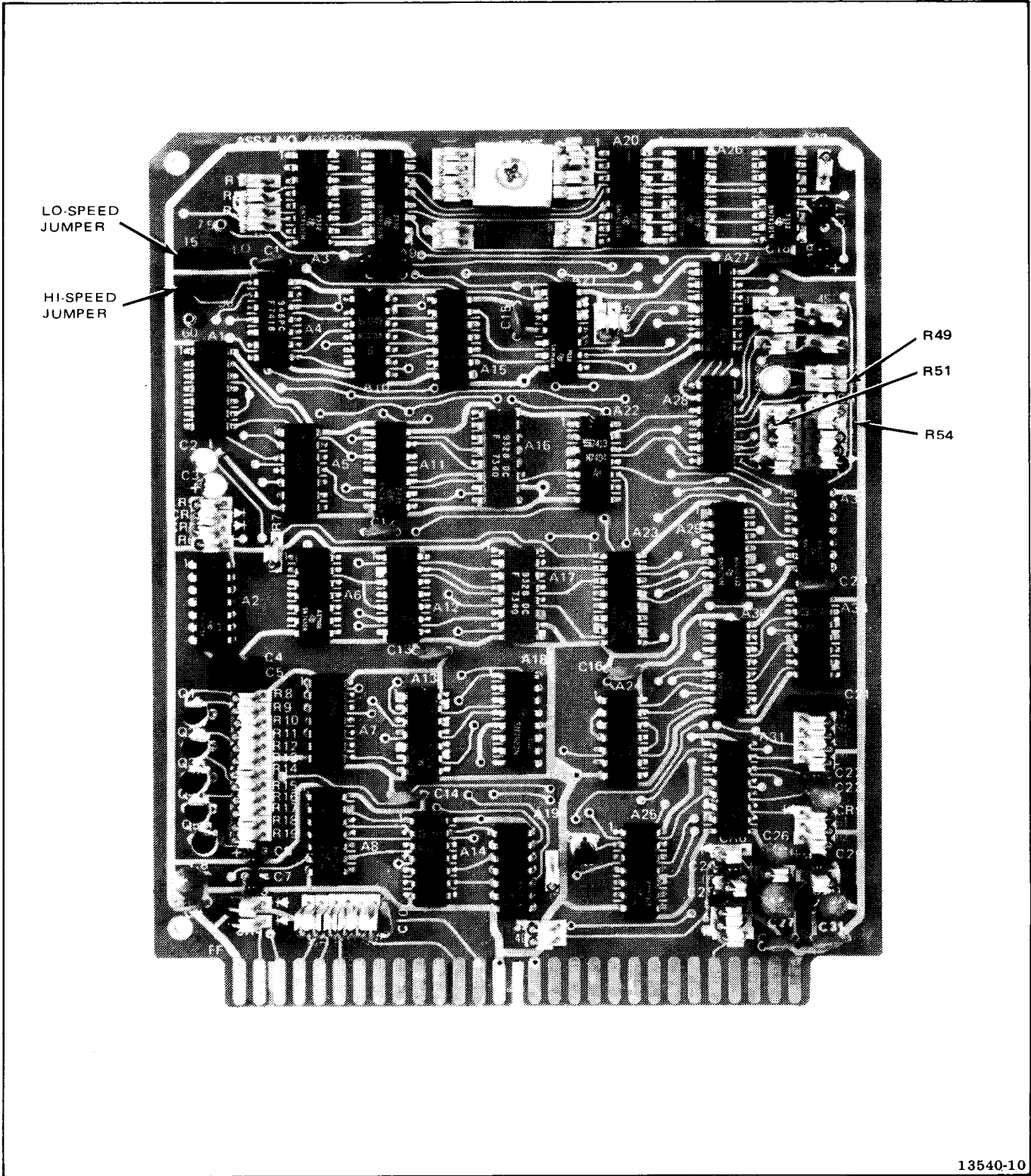

Figure 2-4. Search-to-Cue and Tape Timer PWA

it is desired to optimize for use with 14- to 16-inch reels, perform the following:

1. On the search-to-cue and tape timer PWA (Figure 2-4), remove 33K resistor R51, and replace it with a 68K, 1/4-watt, 5%, composition-type resistor.
2. Remove 36K resistor R54, and replace it with a 20K, 1/4-watt, 2% metal-film resistor.
3. Remove 130K resistor R49 and replace it with a 110K, 1/4-watt, 2% metal-film resistor.
4. Perform the checkout and adjustment procedures outlined in paragraphs 5-22 and 5-23.

SECTION 3

OPERATION

3-1. GENERAL

The following paragraphs provide instructions for operating the MM-1200 Recorder/Reproducer in the fixed and variable speed modes. Also included are descriptions of the various operator controls and their uses. Procedures are given for making recordings with and without using the Sel Sync feature, and for reproducing previously recorded tapes.

3-2. CONTROLS AND INDICATORS

The recorder/reproducer may be turned on and off by means of a main power switch located under the cover on the transport control assembly, which is adjacent to the control box assembly. The POWER switch is shown on Figure 1-4 in Section 1 of this manual.

Table 3-1 lists controls and indicators which are located on the control box assembly.

Table 3-2 lists the controls on the search-to-cue and tape timer assembly.

Table 3-3 lists the operator controls on the electronics assemblies.

3-3. SPEED SELECTION

3-4. Fixed Speed Mode

To operate the system at fixed speeds, ensure that the desired speeds have been selected on the capstan servo PWA and the search-to-cue tape timer PWA in the transport control chassis, as described in paragraphs 2-13 and 2-16.

3-5. Variable Speed Mode

To operate the system at variable speeds using Ampex VS-10 Variable Speed Oscillator, remove the dummy plug from the VARIABLE SPEED connector located on the accessory panel and connect the VS-10 electrical connector in its place. The VS-10 can then be used to vary capstan speed as described in the VS-10 Operation and Maintenance manual, Ampex Catalog No. 4890351.

To operate the system with an external signal generator other than the Ampex VS-10, proceed as follows:

1. Connect the external signal generator as described in paragraph 2-15b.
2. Set the speed strapping on the capstan servo PWA to the normal speed range as shown on Table 2-2.
3. Set the TAPE SPEED switch on the control box assembly to HIGH.
4. Adjust the signal generator frequency control for the desired speed. Table 2-3 shows several signal generator frequencies that will produce specific tape speeds.

3-6. LINE/MONITOR OUTPUT SIGNALS

The line/monitor outputs are shown in Table 3-4 for all audio switching combinations in the record, play, and standby (stop, rewind, or fast forward) modes of operation.

Table 3-1. Control Box Assembly – Controls and Indicators

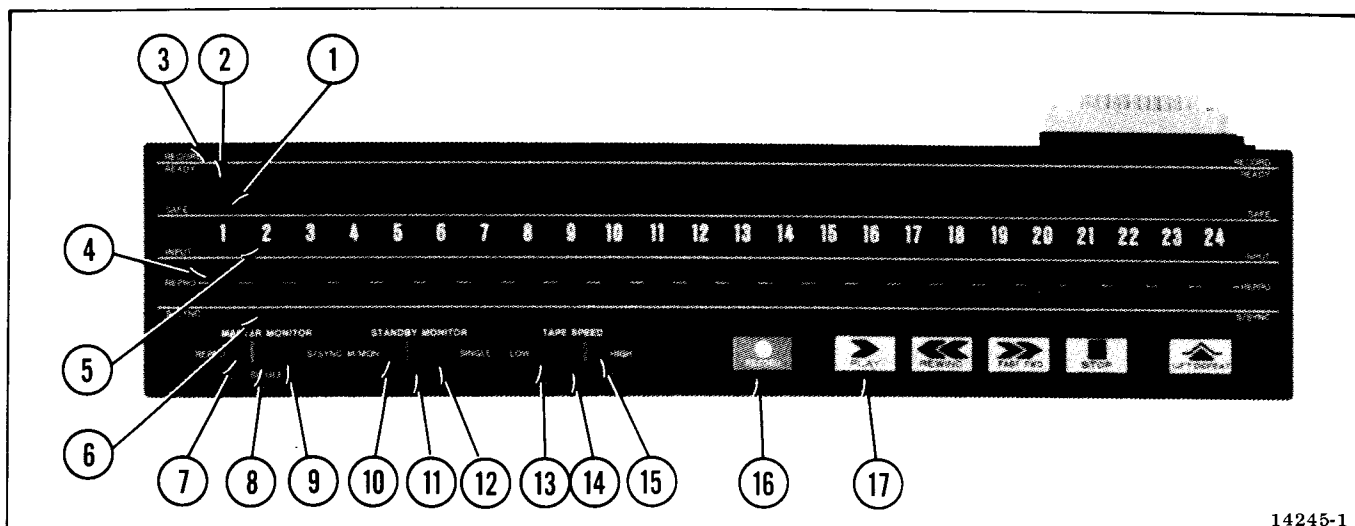

14245-1

| ITEM | DESCRIPTION | FUNCTION |
|------|------------------------------------|--------------------------------------------------------------------------------------------------------------------------------------------------------------------------------------------------------------------------------------------------------------------------------------------------------------------------------------------------------------------------------------------------------------------------------------------------------------------------------------------------------------------------------------------|
| 1 | READY/SAFE toggle switches | Permit channel selection for recording. The READY position enables recording on the corresponding channel when the RECORD and PLAY pushbuttons are depressed simultaneously (see Item 16). The SAFE position inhibits recording. |
| 2 | READY indicator LED | When illuminated, shows that control circuits are set to permit recording on that channel. |
| 3 | RECORD indicator LED | When illuminated, shows that the recording function is enabled on that channel. |
| 4 | INPUT/REPRO/S/SYNC toggle switches | Permit selection of the output signal source for each channel. The INPUT position sets the control circuitry to select the audio input to the machine as the output signal for that channel. The REPRO position sets the control circuitry to select the reproduce head for that channel as the signal source while in the normal reproduce or the record mode. The S/SYNC position sets the control circuitry to select the record head for that channel for use as a reproduce head while the system is in the reproduce or record mode. |
| 5 | INPUT indicator LED | When illuminated, shows that the machine input has been selected for that channel as the audio source to be monitored. |
| 6 | S/SYNC indicator LED | When illuminated, shows that the record head for that channel has been selected as the audio source to be monitored. |
| 7 | REPRO indicator LED | When illuminated shows that the control circuitry has been enabled for the reproduce function. |
| 8 | MASTER MONITOR toggle switch | This switch overrides the individual channel switches and permits selection of all record or all reproduce heads simultaneously for the output audio source. In the REPRO |

Table 3-1. Control Box Assembly – Controls and Indicators (Continued)

| ITEM | DESCRIPTION | FUNCTION |
|---------------|-------------------------------|---------------------------------------------------------------------------------------------------------------------------------------------------------------------------------------------------------------------------------------------------------------------------------------------------------------------------------------------------------------------------------------------------------------------------------|
| 8 (Cont'd) | | <p>position, all reproduce heads are selected regardless of the position of the individual INPUT/REPRO/S/SYNC switch. In the S/SYNC position, all record heads are selected regardless of the position of the individual INPUT/REPRO/S/SYNC switch. In the SINGLE position, output selection is determined by the position of the individual INPUT/REPRO/S/SYNC switches.</p> |
| 9 | S/SYNC indicator LED | <p>When illuminated, shows that the MASTER MONITOR switch circuitry has been set for the master Sel Sync function.</p> |
| 10 | M/MON indicator LED | <p>When illuminated, shows that the STANDBY MONITOR switch has been set to the master monitor mode.</p> |
| 11 | STANDBY MONITOR toggle switch | <p>This switch functions in the standby mode only (STOP, FAST FWD, and REWIND). The M/MON position selects whatever configuration the MASTER MONITOR switch has selected; i.e., REPRO, SINGLE, or S/SYNC. With the STANDBY-MONITOR switch in the SINGLE position, the outputs selected will be determined by the position of the individual INPUT/REPRO/S/SYNC switches (same as SINGLE position of MASTER MONITOR switch).</p> |
| 12 | SINGLE indicator LED | <p>When illuminated, shows that the control circuitry to select the position of the INPUT/REPRO/S/SYNC switches as a monitor audio source has been selected.</p> |
| 13 | LOW indicator LED | <p>When illuminated, shows that the control circuitry for the low tape speed has been selected.</p> |
| 14 | TAPE SPEED toggle switch | <p>This switch permits selection of predetermined high or low capstan motor speeds.</p> |
| 15 | HIGH indicator LED | <p>When illuminated, shows that the control circuitry for the high tape speed has been selected.</p> |
| 16 | RECORD pushbutton switch | <p>This switch, when depressed concurrently with the PLAY switch, enables the selected record control circuitry. This switch remains illuminated while the record function is enabled. To stop the record mode while leaving the tape in motion, press and hold RECORD while momentarily pressing STOP.</p> |
| 17 | PLAY pushbutton switch | <p>This switch, when depressed, enables the play mode and enables the selected reproduce circuitry. This switch illuminates when depressed and remains illuminated while the play mode is enabled.</p> |

Table 3-1. Control Box Assembly – Controls and Indicators (Continued)

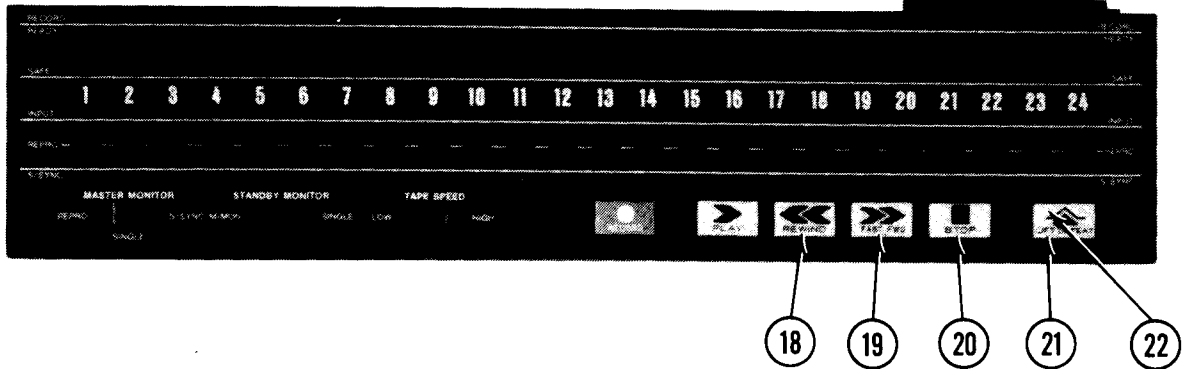

14245-1

| ITEM | DESCRIPTION | FUNCTION |
|------|--------------------------------|----------------------------------------------------------------------------------------------------------------------------------------------------------------------------------------------------------------------------------------------------------------------------------------------------------------------------------------------------------------------------------------------------------------------------------------------------------------|
| 18 | REWIND pushbutton switch | This switch, when depressed, enables the transport rewind function and transfers the signal electronics to standby mode. This switch illuminates when depressed and remains illuminated until cancelled by entering another mode of operation. |
| 19 | FAST FWD pushbutton switch | This switch, when depressed, enables the transport fast forward function and transfers the signal electronics to standby mode. This switch illuminates until cancelled by entering another mode of operation. |
| 20 | STOP pushbutton switch | This switch, when depressed, disables any other mode of operation, stops tape movement, and causes the control circuitry and signal electronics to enter the standby mode of operation. This switch illuminates when depressed and remains illuminated during the standby mode. In the edit mode the STOP indicator is extinguished when LIFT DEFEAT is operated to release the reel brakes, but illuminated when STOP is pressed to re-apply the reel brakes. |
| 21 | LIFT DEFEAT pushbutton switch | This switch, when depressed, causes the tape lifters to operate in reverse of the normal operation position for any mode of operation. In addition, this switch releases the reel brakes when the transport is stopped in the edit mode. To re-apply the brakes, the STOP button is pressed. |
| 22 | SYNC TRANSFER slide switch S58 | Slide switch located beneath the LIFT DEFEAT pushbutton. INPUT position: Toward the transport REPRO position: Away from the transport In the record mode only, the sel sync monitor function for those channels selected to record is transferred to either the input (INPUT) or playback head (REPRO) signals. |

Table 3-2. Search-to-Cue and Tape Timer Controls and Indicators

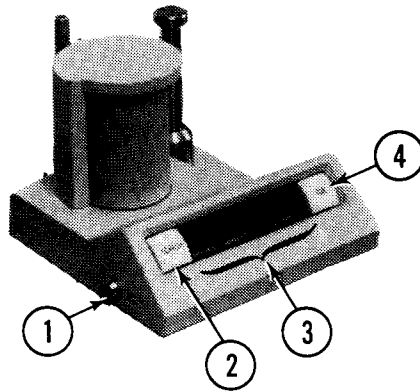

13550-11

| ITEM | DESCRIPTION | FUNCTION |
|------|---------------------------------|--------------------------------------------------------------------------------------------------------------------------------------------|
| 1 | DISPLAY RESET pushbutton switch | This switch resets the tape timer indication to zero. |
| 2 | SEARCH pushbutton switch | This switch initiates the search-to-cue function. The REWIND and FAST FWD indicators are both illuminated during SEARCH. |
| 3 | Counter indicator LEDs | When illuminated, these indicators show in + and - hours, minutes, and seconds the distance the tape has moved from timer zero indication. |
| 4 | CUE pushbutton switch | This switch selects the cue point for the search-to-cue function. |

Table 3-3. Electronics Assemblies – Operator Controls for a Typical Channel

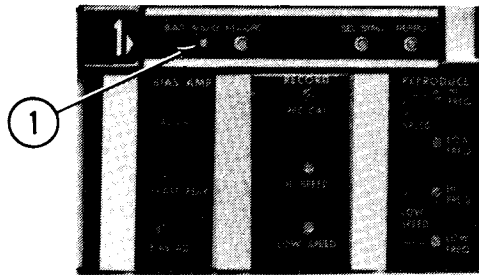

| ITEM | DESCRIPTION | FUNCTION |
|------|--------------------------|-----------------------------------------------------------------------------------------------------------------------------------------------------------------------------------------------------------------------------------------|
| 1 | BIAS/AUDIO toggle switch | This switch selects the input to the vu meter for that channel. The AUDIO position enables the vu meter to indicate input or output audio levels. The BIAS position enables the vu meter to indicate the record amplifier bias current. |

Table 3-3. Electronics Assemblies – Operator Controls for a Typical Channel (Continued)

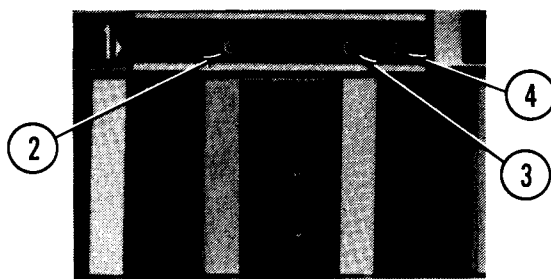

| ITEM | DESCRIPTION | FUNCTION |
|------|------------------|---------------------------------------------------------------------------------------------------------------------------------------------------|
| 2 | RECORD control | This control permits adjustment of the record level audio to the record head for its associated channel. |
| 3 | SEL SYNC control | This control permits adjustment of the reproduce audio level from the record head for its associated channel during the Sel Sync mode. |
| 4 | REPRO control | This control permits adjustment of the reproduce audio level from the reproduce head for its associated channel during the normal reproduce mode. |

Table 3-4. Line Output/Monitor Signals

| SWITCH POSITION | | | MODE | | |
|-----------------|----------------|--------------------------|-------------------------------------------------------|----------------------------|----------------------------|
| STANDBY MONITOR | MASTER MONITOR | INDIVIDUAL CHANNEL | RECORD | PLAY | STANDBY (STOP, FF, or REW) |
| M/MON | REPRO | INPUT REPRO S/SYNC | REPRO REPRO REPRO | REPRO REPRO REPRO | REPRO REPRO REPRO |
| | SINGLE | INPUT REPRO S/SYNC | INPUT REPRO INPUT or REPRO* | INPUT REPRO S/SYNC | INPUT REPRO S/SYNC |
| | S/SYNC | INPUT REPRO S/SYNC | INPUT or REPRO* INPUT or REPRO* INPUT or REPRO* | S/SYNC S/SYNC S/SYNC | S/SYNC S/SYNC S/SYNC |
| SINGLE | REPRO | INPUT REPRO S/SYNC | REPRO REPRO REPRO | REPRO REPRO REPRO | INPUT REPRO S/SYNC |

Table 3-4. Line Output/Monitor Signals (Continued)

| SWITCH POSITION | | | MODE | | |
|---------------------|----------------|--------------------------|-------------------------------------------------------|----------------------------|---------------------------|
| STANDBY MONITOR | MASTER MONITOR | INDIVIDUAL CHANNEL | RECORD | PLAY | STANDBY STOP, FF, or REW) |
| SINGLE (Cont'd.) | SINGLE | INPUT REPRO S/SYNC | INPUT REPRO INPUT or REPRO* | INPUT REPRO S/SYNC | INPUT REPRO S/SYNC |
| | S/SYNC | INPUT REPRO S/SYNC | INPUT or REPRO* INPUT or REPRO* INPUT or REPRO* | S/SYNC S/SYNC S/SYNC | S/SYNC REPRO S/SYNC |

*Depends on the position of the SYNC TRANSFER switch S58 inside the control box. In the record mode only, the Sel Sync monitor function for all channels selected to record is transferred to either the input (INPUT) or playback head (REPRO) signals.

3-7. OPERATING PROCEDURES

3-8. Making a Recording – Without Sel Sync

To make a recording without using the Sel Sync feature, proceed as follows:

1. Clean and demagnetize the tape path as necessary as described in the Maintenance section of this manual.
2. Ensure that the alignment procedures of paragraph 5-38 in the Maintenance section have been performed.
3. Move the end-of-tape arm fully counterclockwise to the locked position.
4. Thread a bulk-erased reel of tape onto the transport as shown in Figure 3-1, close the head gate, and release the end-of-tape arm.
5. On the control box assembly, set the TAPE SPEED switch to the desired speed.
6. Set the STANDBY MONITOR switch to SINGLE.
7. Set the individual INPUT/REPRO/S/SYNC switches to the INPUT position, the same channel READY/SAFE switches to the READY position, and all other READY/SAFE switches to the SAFE position.

8. Set the BIAS/AUDIO switches on the electronics assemblies to AUDIO.
9. With audio sources connected to the appropriate recording channels, adjust the RECORD control on each switcher module (record channel only) for an indication on the associated vu meter of 0 at audio peaks.
10. Cue the tape at the starting point, press the DISPLAY RESET pushbutton on the tape timer for a zero indication if desired, and initiate the record mode by simultaneously depressing the PLAY and RECORD pushbuttons on the control box assembly.

NOTE

To monitor the tape during the record mode, set the MASTER MONITOR switch to REPRO.

11. The record mode can be ended by any of the following methods:
 - a. To stop the recording process and tape motion simultaneously, depress the STOP pushbutton.
 - b. To stop the recording process on all channels but not the tape motion, hold the RECORD pushbutton depressed and momentarily depress the STOP pushbutton.

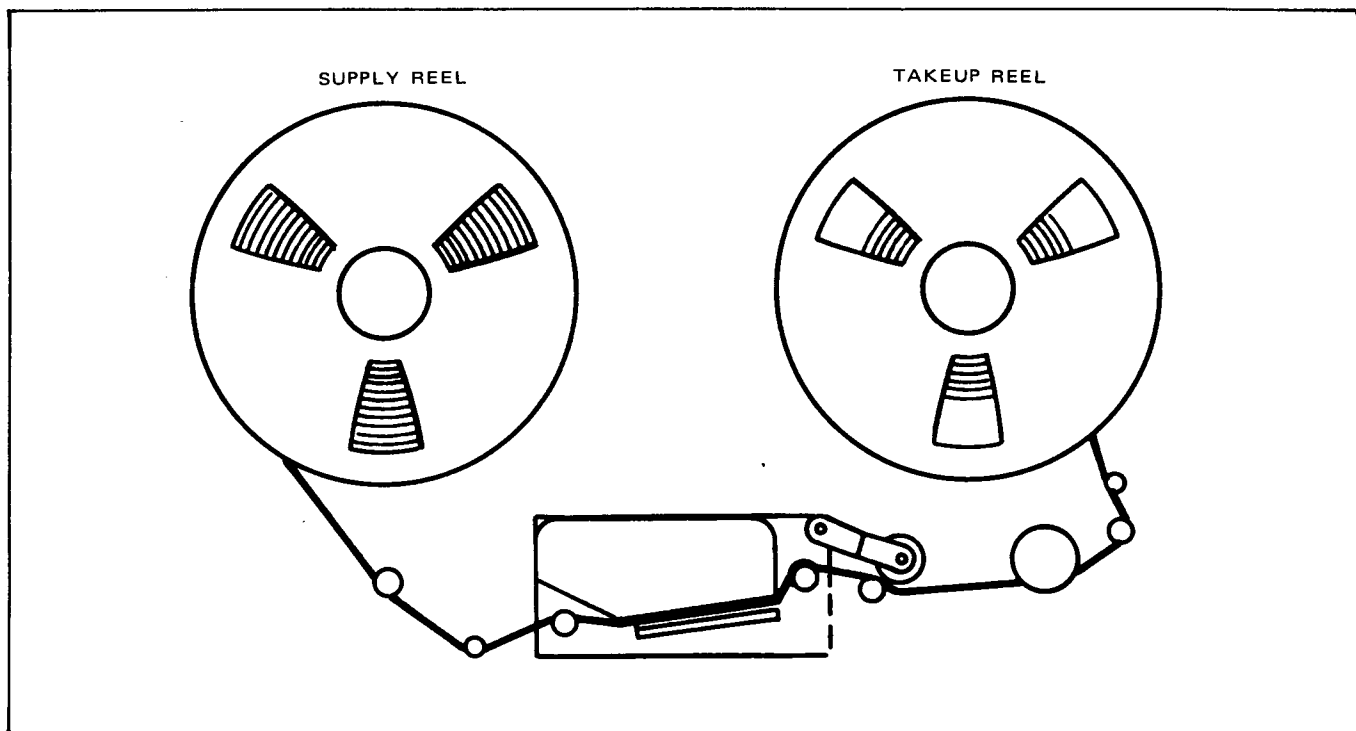

Figure 3-1. Tape Threading Path

c. To stop the recording process on any individual channel without stopping it on the others, set the READY/SAFE switch for that channel to the SAFE position.

3-9. Making a Recording – With Sel Sync

The main function of the Sel Sync feature is to enable the recording of new material precisely in time with previously recorded material. In conventional multi-track recorder/reproducer systems, the different physical locations of the record and reproduce heads along the tape path cause a timing error between material being reproduced on one channel and material being recorded on another. This effect is shown in the upper diagram of Figure 3-2 where material is recorded a fraction of a second before it is reproduced. The result is that the listener who is monitoring one channel while recording on another finishes with the newly recorded track slightly behind the previously recorded track. (See the center diagram of Figure 3-2.) This problem is resolved by using record heads as playback heads such that, while any channel or combination of channels is being

monitored by the associated record head(s), the remaining channel(s) can be simultaneously recorded, thereby eliminating the time displacement error. (See the bottom diagram of Figure 3-2.)

To make a recording using the Sel Sync feature, proceed as follows:

1. Clean and demagnetize the tape path as necessary as described in the Maintenance section of this manual.
2. Ensure that the audio alignment procedures in the Maintenance section have been accomplished.
3. Move the end-of-tape arm fully counterclockwise to the locked position.
4. Thread a tape with a previously recorded channel or channels onto the tape transport assembly as shown in Figure 3-1, close the head gate, and release the end-of-tape arm.

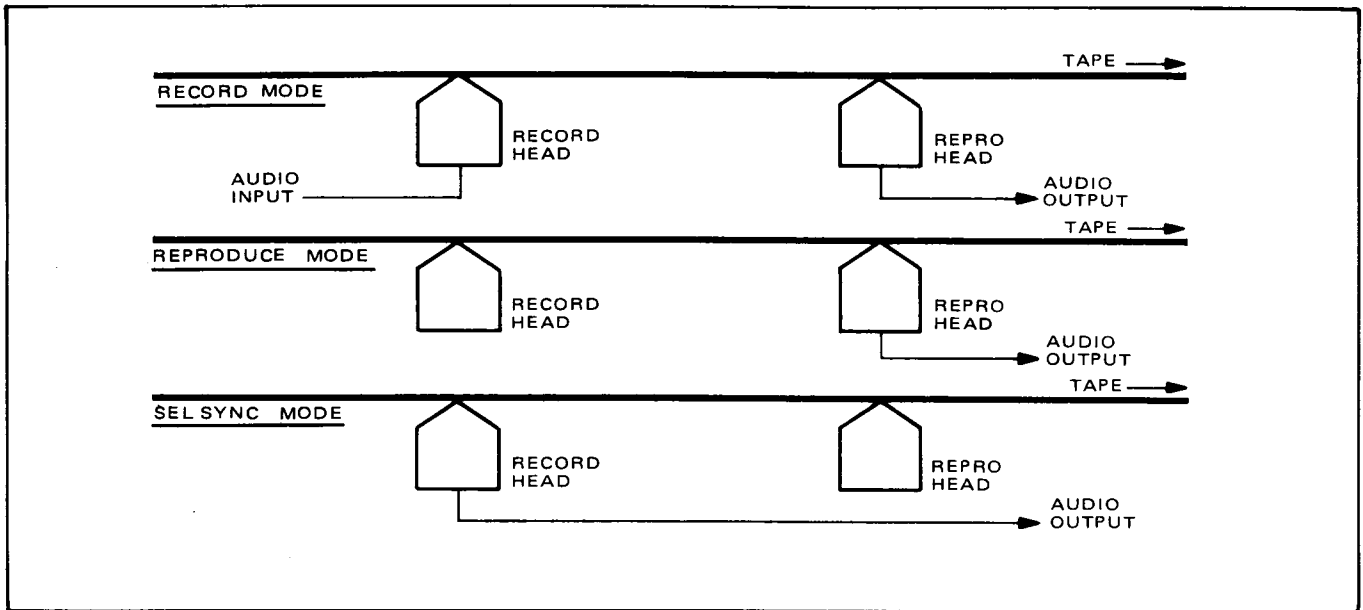

Figure 3-2. Head Usage for Different Operating Modes

5. Set the TAPE SPEED switch on the control box assembly to the position used for recording prerecorded channels.
6. Set the MASTER MONITOR switch to the SINGLE position.
7. Set the READY/SAFE switch(es) of the channel(s) to be recorded to the READY position, and all others to the SAFE position.
8. Set the INPUT/REPRO/S/SYNC switch (es) of the channel(s) to be monitored to the S/SYNC position, and of the channel(s) to be recorded to the INPUT position.
9. Set the BIAS/AUDIO switches on the electronics assemblies to AUDIO.
10. Set the STANDBY MONITOR switch to SINGLE.
11. With audio sources connected to the appropriate recording channels, adjust the RECORD control(s) on the associated audio switcher so that the associated vu meters indicate audio peak of 0.
12. Move the tape to the starting point, depress the tape timer DISPLAY RESET pushbutton for a zero indication if desired, and initiate the record mode by concurrently depressing the PLAY and RECORD pushbuttons on the control box assembly.
13. The record mode can be stopped by any of the following methods:
 - a. To stop the recording process and tape motion simultaneously, depress the STOP pushbutton.
 - b. To stop the recording process on all channels but not the tape motion, hold the RECORD pushbutton depressed and momentarily depress the STOP pushbutton.
 - c. To stop the recording process on any individual channel without stopping it on the others, set the READY/SAFE switch for that channel to the SAFE position.

3-10. Reproducing a Previously Recorded Tape

Reproduce a previously recorded tape as follows:

1. Clean and demagnetize the tape path as described in the Maintenance section of this manual.
2. Ensure that the audio alignment procedures in the Maintenance section have been accomplished.
3. Move the end-of-tape arm fully counterclockwise to the locked position.
4. Thread the tape to be reproduced onto the tape transport assembly as shown in Figure 3-1.
5. Set the TAPE SPEED switch on the control box assembly to the desired position.
6. Set the MASTER MONITOR switch to the REPRO position, and the STANDBY MONITOR switch to the M/MON position.
7. Set all READY/SAFE switches to the SAFE position.
8. Depress the PLAY pushbutton switch on the control box assembly and adjust the appropriate REPRO controls on the switcher modules to obtain the desired audio levels.
9. Depress the STOP pushbutton to stop the reproduce mode. If the tape supply is exhausted before the STOP pushbutton is depressed, the end-of-tape switch will actuate, the tape will stop, and the system will automatically revert to the standby mode.

3-11. Fast Winding

For tape editing or cueing, the tape may be wound in either direction by depressing the FAST FWD or REWIND pushbuttons. These pushbuttons may be depressed at any time without depressing the STOP pushbutton first. When the desired point on the tape is reached, depress the STOP pushbutton to stop tape motion.

3-12. Fast Winding – Search-to-Cue

To use the search-to-cue function, proceed as follows:

1. When it is desired to return to a specific point on a tape, depress the CUE pushbutton on the tape timer assembly when the tape is at the desired return point.

NOTE

The CUE pushbutton may be depressed either when the tape is in motion or when it is stopped.

2. Record or reproduce the tape as described in the preceding paragraphs.
3. To return to the cue point, depress the SEARCH pushbutton on the tape timer assembly.
4. To cancel the search function, depress the STOP pushbutton on the control box assembly.
5. To initiate the play mode as soon as the cue point is reached, depress the PLAY pushbutton on the control box assembly after depressing the SEARCH pushbutton on the tape timer.
6. To enter the fast forward or rewind mode of operation while the search function is engaged, depress the FAST FWD or the REWIND pushbutton on the control box assembly.

NOTE

Depressing the FAST FWD or the REWIND pushbutton on the control box assembly will override the search function as long as the pushbutton is held depressed. When the FAST FWD or REWIND pushbutton is released, the search function will continue until the cue point is reached or the search function is manually cancelled.

3-13. Tape Lifter Defeat

The tape lifter mechanism, which automatically lifts the tape away from the heads during the fast wind modes of operation, may be defeated by depressing the LIFT DEFEAT pushbutton. Holding the LIFT DEFEAT pushbutton depressed during the fast wind modes permits monitoring of the reproduced audio signal at fast wind speeds for cueing purposes. To minimize head wear, it is good practice to avoid unnecessary use of this feature. Alternately, the LIFT DEFEAT pushbutton may be used during the record or play modes to lift the tape from the heads.

SECTION 4

THEORY OF OPERATION

4-1. GENERAL

This section contains an overall block diagram, detailed block diagrams, and partial schematic diagrams relating to the operational theory of the MM-1200 Recorder/Reproducer. The operation of each component or assembly is discussed with regard to its function and its relation to the overall system. Figure 4-1 is an overall block diagram of the MM-1200 operational functions. As shown on the diagram, the audio signal paths are controlled by an audio switcher which is controlled by the audio control portion of the control box assembly. The record, reproduce, Sel Sync, erase, bias, and metering functions are all routed by the audio switcher module. The tape motion and motion sensing functions are all handled by the transport control assembly. Not shown on the diagram is the multisection power supply which provides source power to the various active components, such as amplifiers, relays, motors, and status displays.

4-2. AUDIO ELECTRONICS

One recording mode and two reproduce modes are available in each channel of the MM-1200 Recorder/Reproducer. Application of these modes is accomplished in the audio switcher module, the record amplifier, the reproduce amplifier, the bias amp module, and the transport control assembly, all of which are operator controlled. The following paragraphs describe the audio switching function completely and as much of the transport control function as is necessary to understand the audio signal path routing. The operation of the transport control circuitry is described in paragraphs 4-24 through 4-43.

4-3. Record

One or more channels on the MM-1200 may be set up for recording at any one time. Recording on any channel is initiated by setting the channel READY/SAFE switch to READY and simultaneously depressing the PLAY and RECORD push-buttons. As shown in Figure 4-2, the incoming audio source is routed into the audio switcher module, through the RECORD control, out of the switcher module, and into the record amplifier. In the record amplifier, the signal is amplified and sent through bias trap L1/C5 to contact 3 of relay K1. This relay is operated by a logic 0 pulse from the RECORD pushbutton on the control box. The signal is then sent to contact 16 of relay K3. The record pulse also operates relay K3, and a logic 0 signal from the transport control assembly holds relays K1 and K3 in the record (enabled) position. The audio signal from the RECORD amplifier is then routed through relay K3 into the record head.

An input from the bias oscillator is processed by the bias amp module; then routed through contracts 6 and 7 of relay K3; then through C40, C39, and R8; and mixed with the audio signal as it leaves contact 1 of relay K1 and goes through relay K3 to the record head. The bias signal is prevented from returning to the record amplifier by a bias trap L1/C5. The return side of the record head goes through contacts 9 and 10 of relay K3 and the BIAS CAL control to ground so that the BIAS CAL control can be used to set a bias reference point on the vu meter when the AUDIO/BIAS switch is set to the BIAS position.

Another output is taken from the equalizer on the record amplifier, goes through the REC CAL control, and is sent to the audio switcher where it goes to contact 5 of relay K2. Relay K2 is operated

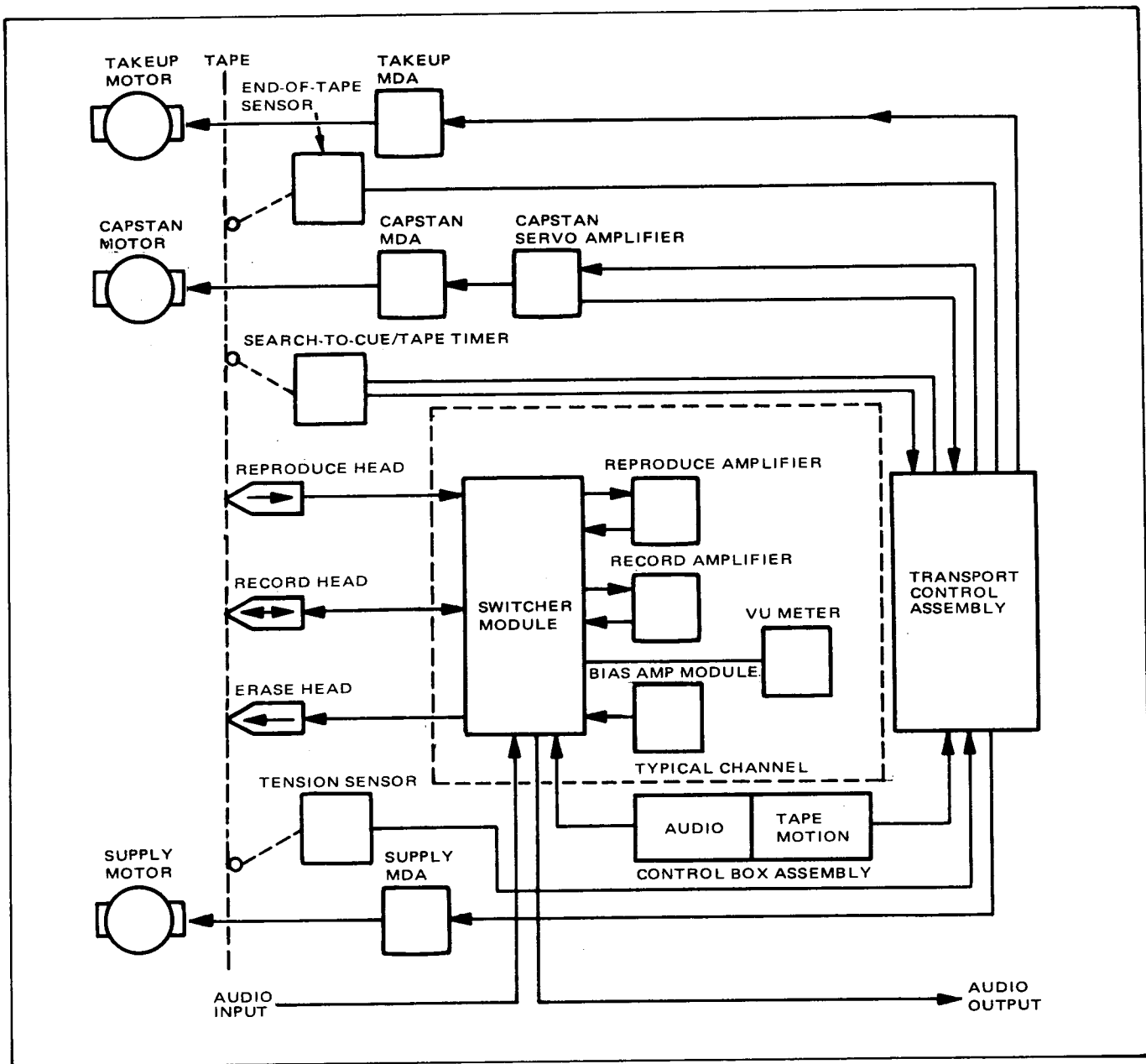

Figure 4-1. MM-1200 Block Diagram

by the INPUT/REPRO/S/SYNC switch which selects the input audio from the record amplifier or the reproduce head, depending on whether the switch is set to the INPUT or REPRO position. The REC CAL control is used to establish a reference indication on the vu meter after the recording level is set. The input signal then flows through relay K2 to the reproduce amplifier where it is

amplified and sent to the line output connector and the vu meter.

4-4. Reproduce

Signal paths for the Sel Sync reproduce and the normal reproduce modes are shown in Figure 4-3. In the normal reproduce mode of operation, the

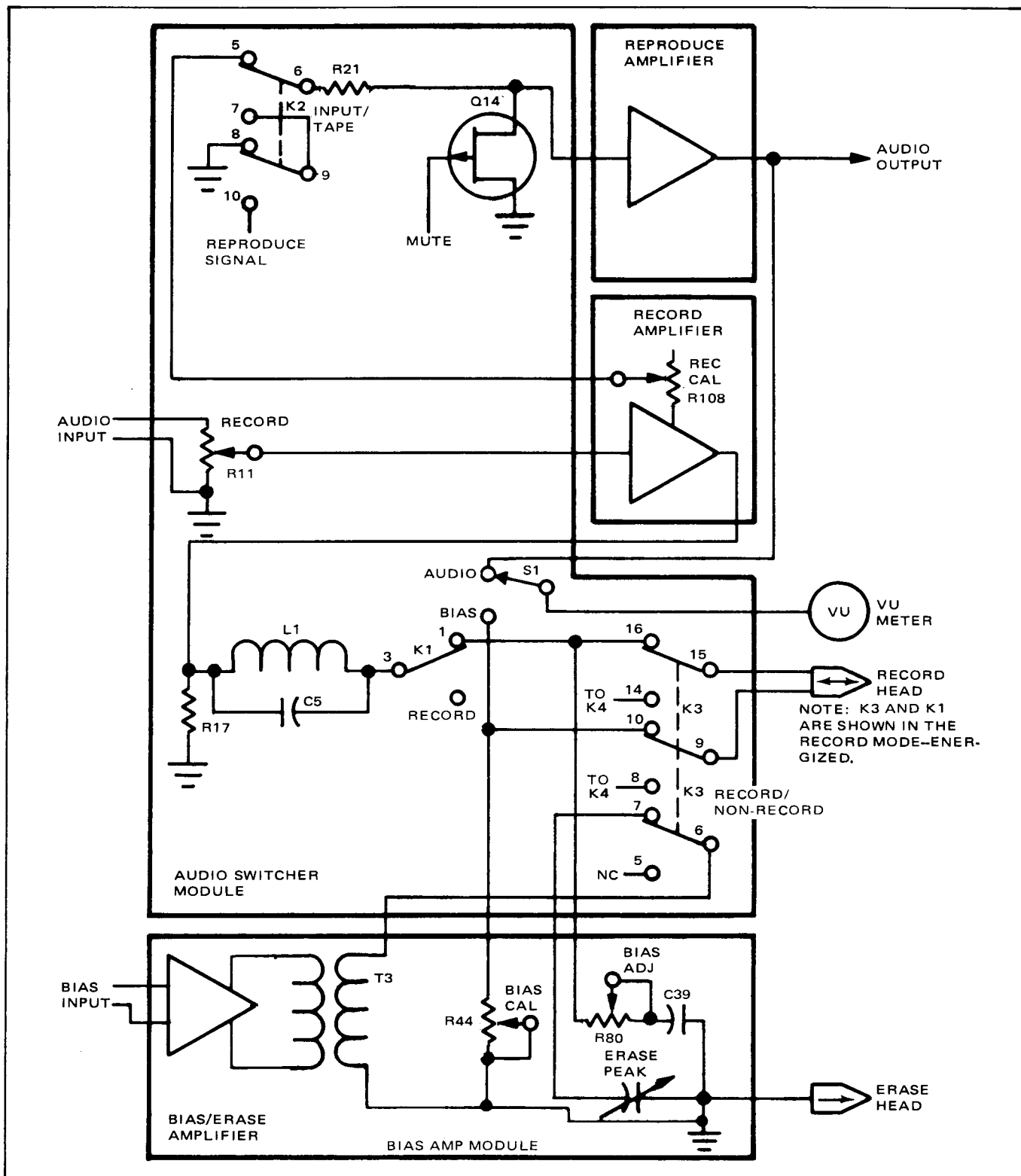

Figure 4-2. Record Signal Path Partial Schematic

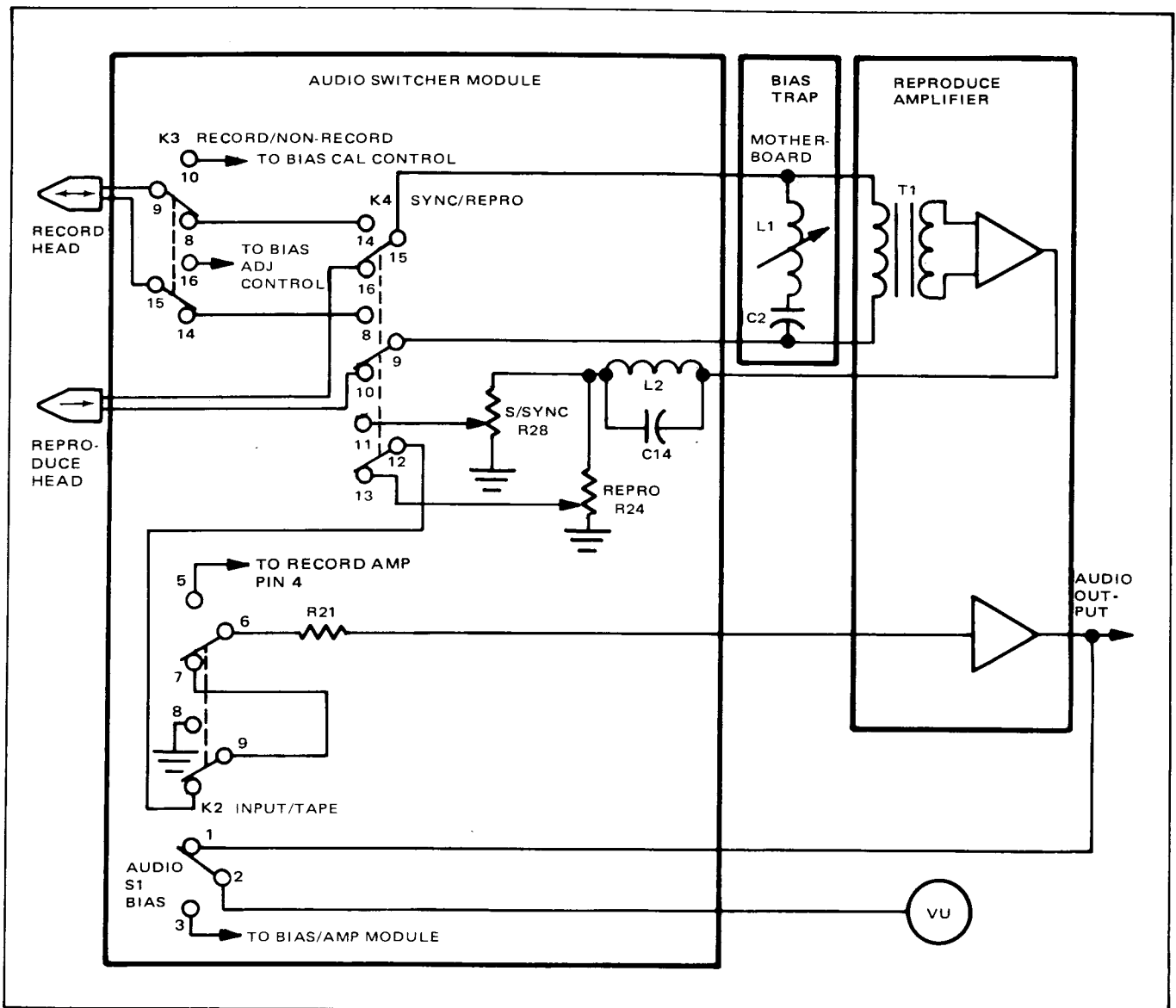

Figure 4-3. S/Sync and Repro Signal Path Partial Schematic

MASTER MONITOR switch on the control box assembly is set to the REPRO position; or the MASTER MONITOR switch may be set to the SINGLE position and the individual INPUT/REPRO/S/SYNC switches may be set to the REPRO position. Setting either of these switches to the REPRO position configures relay K4 to provide a signal path through contacts 9/10 and 15/16 from the reproduce heads through the audio switcher module. The signal goes through the electronic assemblies' motherboard, which

contains a bias trap, and to an amplifier section of the reproduce amplifier. The amplified signal is sent back to the audio switcher module through another bias trap (L2/C14) used for bias suppression, and to two potentiometers (SEL SYNC and REPRO). Since relay K4 is configured to the normal reproduce position, the signal is passed through the REPRO potentiometer, through contacts 12 and 13 of relay K4, and is routed to contact 10 of relay K2. Reproduced audio levels are monitored by the vu meter when the AUDIO/BIAS

switch on the audio switcher module is set to AUDIO.

When the MASTER MONITOR switch or the individual INPUT/REPRO/S/SYNC switches are set to the S/SYNC position, the signal path is identical to that described previously except that the S/SYNC position of either switch configures relay(s) K4 to select the record heads to be used as reproduce heads. When the Sel Sync mode is selected, usually at least one of the record heads in the record head stack is used in the record mode. Any bias signal pickup by adjacent record heads being used in the reproduce mode is trapped out by the bias trap on the motherboard and by the bias trap (L2/C14) in the audio switcher module.

4-5. Individual Channel Audio Switching

The audio switching is controlled by the audio switcher module for each channel and is dependent on manual operation of certain control switches contained on the control box assembly. Figure 4-4 is a partial schematic diagram showing the control signal paths in the audio switcher module and the associated switches in the control box assembly.

4-6. INPUT/REPRO/S/SYNC Switch Circuit. The INPUT/REPRO/S/SYNC switch circuit of each channel provides three controlling signals according to its physical position. In the REPRO position, as shown in Figure 4-4, both diodes CR4 and CR5 are back biased providing a neutral (neither +27V nor ground) at the diodes' common point. In the S/SYNC position, the 'A' contacts are connected as shown, and the 'B' contacts 2 and 3 are connected. This contact configuration forward biases diode CR5 and causes an output signal of +27V to appear at the diodes' common point. In the INPUT position, the switch 'B' contacts are as shown and the 'A' contacts 1 and 3 are connected. This contact configuration forward biases diode CR4 and causes a ground signal to appear at the diodes' common point. The signal from the common point of diodes CR4 and CR5 is connected to the approximate mid-point of a voltage divider consisting of resistors R24, R31, R32, R26 and R25. The voltages appearing at the various points on this divider change when the conditions imposed by the INPUT/REPRO/S/SYNC

switch appear at the divider mid-point. The +27-volt high, the ground low, and the neutral at the divider set the turn on/turn off conditions for Q9 and Q15, which in turn control relay drivers Q7 (K4) and Q10 (K2). Relay K4 selects either the reproduce head or the record head tape output while K2 selects that tape signal or the audio input to the reproduce system for monitoring.

REPRO Position. With the INPUT/REPRO/S/SYNC switch set to the REPRO position, the neutral signal appears at the divider mid-point and the voltages appearing on the divider are as shown in Figure 4-5.

Referring to Figure 4-4, the +26.4 volts on the base of transistor Q9 forward biases it, causing the supply voltage to appear at its collector and consequently at the junction of diode CR4 and resistor R15. Resistor R14 supplies current to the base of transistor Q7, which forward biases that transistor and closes the path to ground such that relay K4 is energized. In a like manner, the +17.8 volts at resistor R44 forward biases Q15, which applies a positive voltage to the base of transistor Q10, which is also forward biased and provides a ground path for relay K2, energizing it also.

This configuration, in which relays K2 and K4 are both energized, is the reproduce configuration, since energizing relay K4 selects the reproduce head as an audio source and energizing relay K2 selects the tape as the source of signal to be sent to the reproduce amplifier.

S/SYNC position. With the INPUT/REPRO/S/SYNC switch set to the S/SYNC position, the +27-volt signal appears at the divider mid-point and the voltages on the divider are as shown in Figure 4-6.

Referring to Figure 4-4, the +27 volts on the base of transistor Q9 reverse biases it, causing the voltage at the junction of CR4 and R15 to drop to zero. There will also be zero volts at the base of transistor Q7. As a result, Q7 is also reverse biased and the ground path for relay K4 no longer exists, causing relay K4 to de-energize. Similarly, the voltage at the base of transistor Q15 is +26.4 volts, which also causes a reverse-bias condition and shuts off that transistor. Then the voltage appearing at

the base of transistor Q10 creates a forward-bias condition, which turns that transistor on and provides a ground path for relay K2 energizing it.

This condition, in which relay K2 is energized and relay K4 is de-energized, is the Sel Sync configuration, since de-energizing relay K4 selects the record head as an audio source and energizing relay K2 selects the tape as the source of signal to be sent to the reproduce amplifier.

INPUT Position. With the INPUT/REPRO/S/SYNC switch set to the INPUT position, the ground signal appears at the divider mid-point and the voltages on the divider are as shown in Figure 4-7.

Referring to Figure 4-4, transistor Q9 is forward biased; the supply voltage appears at its collector and consequently at the junction of diode CR4 and resistor R14. Transistor Q7 is biased through zener diode VR1 and closes the path to ground such that relay K4 is energized. The zero volts at the cathode of CR3 turns A10 off, thereby opening the ground path to relay K2, de-energizing it.

This condition, in which relay K2 is de-energized, is the INPUT configuration, since de-energizing relay K2 selects the input audio as the source of signal to be sent to the reproduce amplifier.

4-7. Sync Transfer Switch. The sync transfer switch (S58) applies either a logic high or a logic low signal through resistor R3 (located on the motherboard) to the base of transistor Q15 in the switcher modules (see Figure 4-4). The base of transistor Q15 will have a logic high signal on it whenever the individual INPUT/REPRO/S/SYNC switches or the MASTER MONITOR switch is set to the S/SYNC position. All other positions of these switches will result in a logic low being applied to the base of transistor Q15.

With the sync transfer switch on INPUT, the logic high signal at the base of transistor Q15 turns that transistor off which, during record mode, permits the tape/input relay K2 to be selected to the input monitoring position. Therefore any channel(s) selected to Sel Sync will be transferred to input monitoring during record mode.

However, if the transfer switch is set to REPRO, a logic low signal is applied at the base of transistor

Q15 which turns it on, thereby holding the tape/input relay K2 to the tape monitoring position. Consequently, any channel(s) selected to Sel Sync will be transferred to reproduce monitoring during record mode.

4-8. Audio Mute Function. Changing the position of any switch that controls the sync/repro relay K4 will result in a voltage change at the base of emitter follower Q11. The output of Q11 is connected to a phase inverter consisting of transistor Q13 and its associated components. Any change in signal at the base of Q13 will turn transistor Q12 on, resulting in a logic 0 appearing at the collector of Q12. This signal, in turn, will turn on FET Q14 which causes the audio signal coming from relay K2 to be shorted to ground, thereby precluding switching transients from being sent to the reproduce amplifier and causing disturbing noises in external equipment. The time duration during which FET Q14 mutes the audio signal is determined by resistor R36 and capacitor C12.

4-9. Record Function. To initiate the record function, the READY/SAFE switch on the control box assembly must be set to the READY position. This permits a record pulse (logic 0), caused by momentarily depressing the RECORD and PLAY pushbuttons simultaneously, to be sent through the contacts of the READY/SAFE switch to the emitter of transistor Q8. If relay K4 is in the sync position, it must be switched to the repro position by the record pulse, through resistor R23 to transistor Q9 and the remaining K4 energizing circuits. When relay K4, contacts 5 and 6, are open, Q8 is allowed to turn on and provides a ground path for relay K3, which causes it to energize and switch to its record mode. When this occurs, a ground path is also established through contacts 12 and 13 of relay K3 which is connected to the record hold signal (logic 0) which comes from the transport control assembly through the READY/SAFE switch for that channel. This causes transistors Q2 and Q3 to turn on. When Q2 is on, it turns on transistor Q4 which, in turn, turns on current booster Q5. This action turns on transistor Q6 which provides a ground path for relay K3 as long as the READY/SAFE switch is in the READY position. When transistor Q3 turns on, as stated above, it provides power to close the

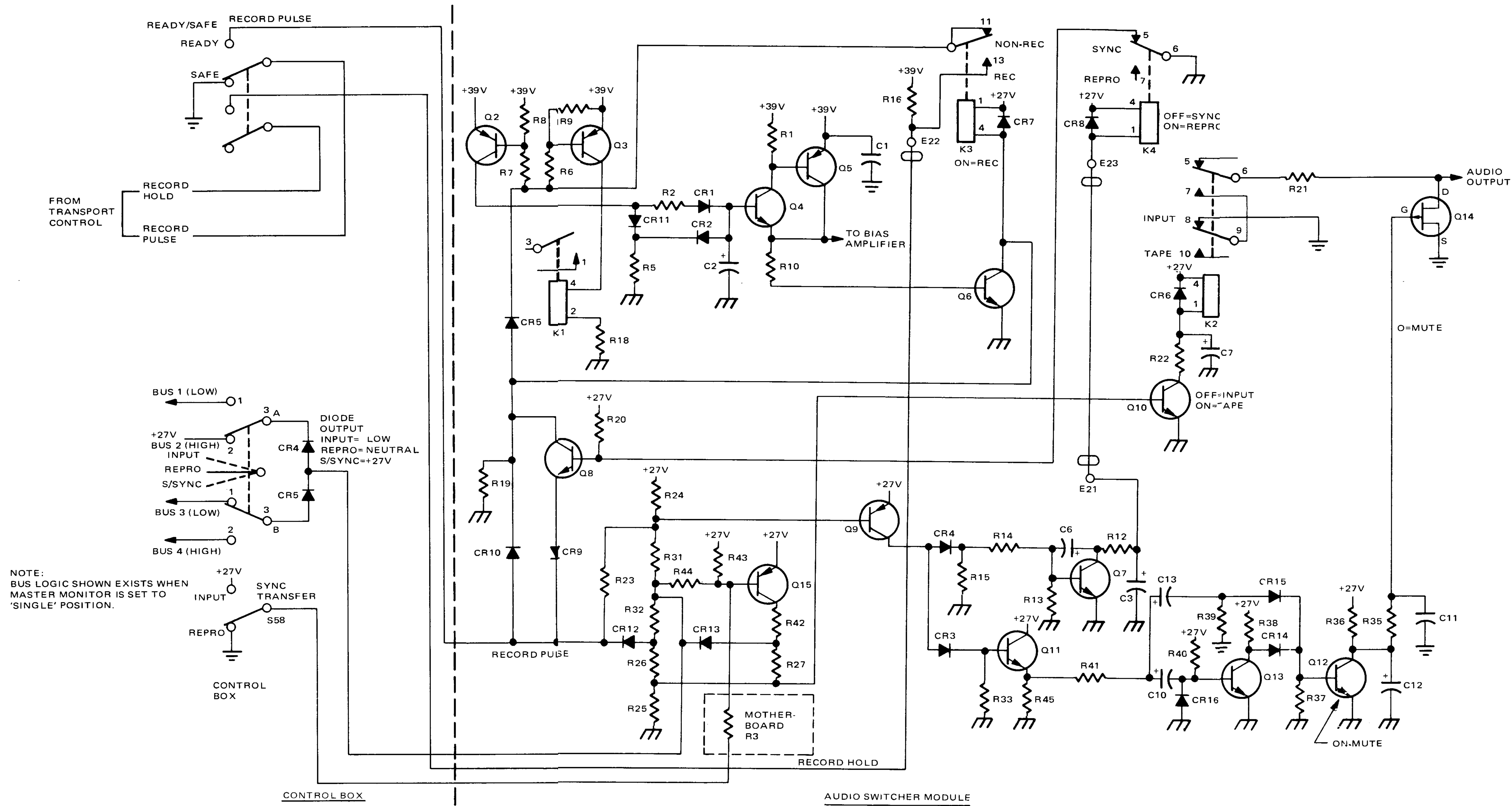

Figure 4-4. Audio Control Partial Schematic

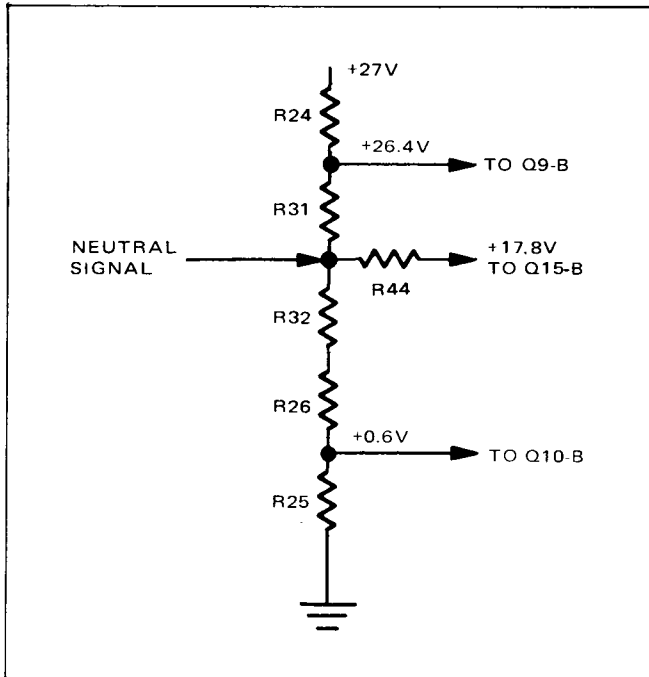

Figure 4-5. Divider Voltages with Neutral Control Signal (REPRO)

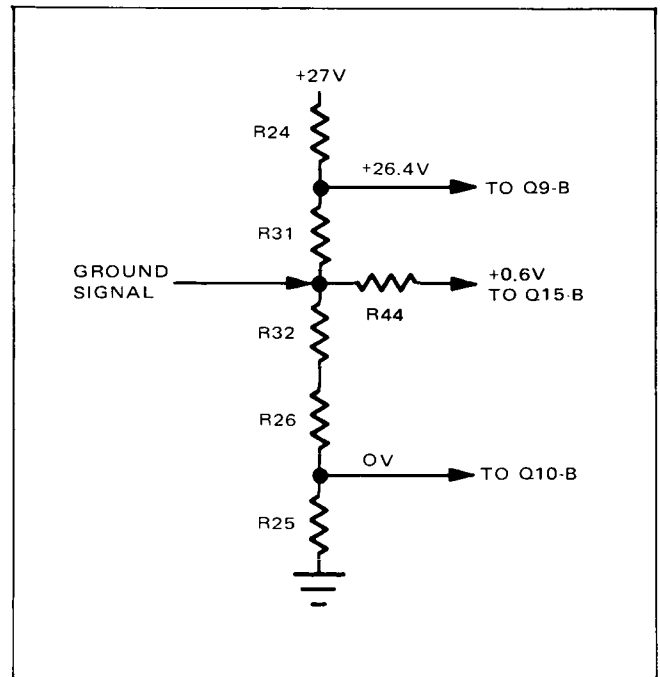

Figure 4-7. Divider Voltages with Ground Control Signal (INPUT)

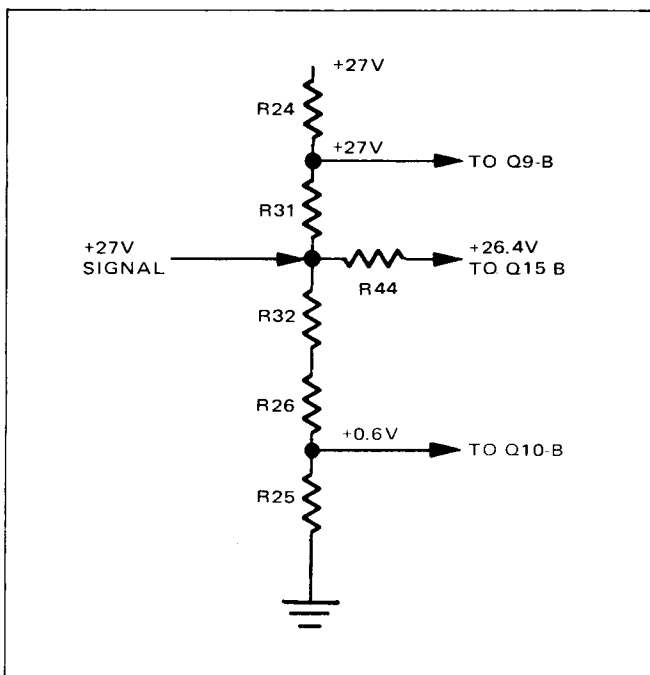

Figure 4-6. Divider Voltages with +27V Control Signal (S/SYNC)

record relay K1 completing the record function. When the transport movement is stopped or the READY/SAFE switch is moved out of the SAFE position, the holding ground is disconnected at relay K3. Transistors Q4 and Q5, capacitor C2, and resistor R5 constitute a time delay circuit which allows the bias to decay exponentially when the record mode is ended.

4-10. Master and Standby Monitor Audio Switching

The individual channel switches operate from the SINGLE bus levels given in Table 4-1. By changing the bus levels, the individual channel switches can be overridden by a combination of bus levels which yields only the +27V high (S/SYNC) or neutral (REPRO) levels, regardless of the position of the individual channel switches. With highs on all four buses, CR5 (Figure 4-4) will be forward biased, regardless of the position of the individual channel switch. With highs on buses 1 and 2 and lows on 3 and 4, the CR4/CR5 diode output will be neutral regardless of the switch position. The four bus levels are provided by the MASTER

Table 4-1. Audio Switching Bus Levels

| TRANSPORT MODE | STANDBY MONITOR SWITCH POSITION | MASTER MONITOR SWITCH POSITION | BUS 1 | BUS 2 | BUS 3 | BUS 4 | E301 | E302 | E303 | J1 Pin BA (Channel 1) |
|----------------|---------------------------------|--------------------------------|-------|-------|-------|-------|------|------|------|----------------------------------------------------------------------|
| STANDBY | SINGLE | ANY POSITION | Low | High | Low | High | High | Low | High | { Input = Gnd S/Sync = +27V Repro = Neutral +27V Neutral |
| ANY | M/MON | SINGLE | Low | High | Low | High | Low | High | Low | |
| ANY | M/MON | S/SYNC | High | High | High | High | Low | High | Low | |
| ANY | M/MON | REPRO | High | High | Low | Low | Low | High | Low | |

MONITOR and STANDBY MONITOR switch circuits shown in the simplified schematic of Figure 4-8.

4-11. STANDBY MONITOR Switch Circuit. The position of the STANDBY MONITOR switch determines whether the standby mode (Fast Forward, Rewind, and Stop) outputs of the recorder/reproducer are derived from the position of the MASTER MONITOR switch or the individual channel INPUT/REPRO/S/SYNC switches.

The base of Q4 on the standby switcher PWA will be high if in the standby mode, and if the STANDBY MONITOR switch is in the SINGLE position. Under these conditions, CR50, 51, and 52 are all back biased, and Q4 is forward biased by the high on its base through R7. When Q4 turns on, its collector goes low enough to turn Q3 on, which in turn back biases Q5. The Q4 emitter is sufficiently positive to forward bias Q8, making E302 low. The level at the Q4 collector also forward biases Q6 which saturates, making E303 high.

In the MASTER MONITOR position (as well as during the play mode or with operation of the LIFTER DEFEAT switch) the Q4 base is brought low by forward-biased diode CR50, 51, or 52. With Q4 shut off, its collector goes high, turning Q3 off, which in turn forward biases Q5 into saturation. Transistor Q8 is turned off by the low from the Q4 emitter. E302, then, is high. The high at the Q4 collector also turns Q6 off, and since Q7 is turned on, the E303 line is low.

The E302/E303 lines are protected against excessive loading by the Q1/Q2 circuit. When E303 is high, transistor Q6 is saturated. Q2 is held off by the high on E303. However, as the load on E303 increases, the voltage drop across R14 increases until this voltage plus the voltage at the base-emitter junction of Q6 is greater than the drop across CR7 and CR8. Q6 starts turning off and, as the collector voltage drops, Q2 is turned on through CR5 and R7, charging capacitor C1. When the voltage on C1 is greater than the VR2 breakdown voltage, Q1 turns on. When Q1 turns on, it turns Q2 on harder, latching it.

As transistor Q1 is turned on, the E302/E303 lines are neutralized by turning off their source transistors, Q5 and Q6. As the Q1 collector goes low, Q3 turns on, which turns Q5 off, neutralizing the E302 line. Q4 is turned off through CR3; its collector goes high, which turns off Q6. The Q4 emitter goes low, turning off Q8, which neutralizes the E303 line.

An excessive load on the E302 line, when high, similarly starts the Q5/Q6 turn off. As the current across R13 increases, the Q5 base-emitter voltage increases; Q5 starts to turn off. As the Q5 collector voltage drops, Q2 is turned on through CR6 and R7. As Q2 turns on, the sequence described above takes place. The circuit is reset when the power is turned off and C1 discharges through CR1.

4-12. MASTER MONITOR Switch Circuit. If the transport is in the standby SINGLE mode, E302 will be low and E303 high. Entering the play mode from standby or engaging the lifter defeat function will automatically make E302 high and E303 low, regardless of the position of the STANDBY MONITOR switch (see paragraph 4-11). The E302/303 levels in combination with the hardwired levels on the MASTER MONITOR switch, S49, contacts provide the four bus levels to the individual channel INPUT/REPRO/S/SYNC switches. See Table 4-1 and Figure 4-8.

With the MASTER MONITOR switch in SINGLE, and with the STANDBY MONITOR switch set to M/MON, the wiper contacts of the MASTER MONITOR switch are in their centered position as shown in Figure 4-8. Bus 1 is low through the ground at S49D-1. Bus 2 is wired high. Bus 3 is low through S49C-2. Bus 4 is high through S49B-1. The MASTER MONITOR switch is overridden with the transport in the standby mode and the STANDBY MONITOR switch set to SINGLE. Line E302 is low, and E303 high. Bus 1 is low through CR53 regardless of the position of the S49A wiper. Bus 2 is wired high. Bus 3 is low through CR57. Bus 4 is high through CR54. The individual channel switches are then operable.

In the S/SYNC position, the S49A and C wipers move to position 1; the S49B and D wipers are centered at position 1. Buses 1 and 3 are high through the connection to E302. Bus 2 is wired high, and bus 4 is also connected high through S49-1. With all buses high, the output to the individual channels will be at the +27V high, forcing all channels to the S/SYNC function.

In the REPRO position, the S49B and D wipers move to position 2; the S49A and C wipers are centered at position 2. Bus 1 is high through the S49D-2 connection to E302. Bus 2 is wired high. Bus 3 is low through the S49C-2 contact. Bus 4 is low through the S49B-2 connection to E303. These bus levels result in a neutral to the individual channels, forcing all channels to the REPRO function.

4-13. LIFT DEFEAT Switch Circuit. Depressing the LIFT DEFEAT pushbutton on the control box when the system is not in the reproduce mode will

also provide a ground to the base of transistor Q4 on the switchboard assembly (Figure 4-8) and accomplish the same function of simulating the reproduce mode to the switcher electronics so that the tape audio signal can be monitored at fast wind speeds.

4-14. READY/SAFE Switch Circuit. When the READY/SAFE switch is in the SAFE position, the record pulse and the record hold signals are prohibited from entering the audio switcher module. When the READY position is selected, both these signals are permitted through to the audio switcher module.

4-15. Status Display Circuits

Except for the TAPE SPEED switch, all the status displays described below are related to audio switching functions. See Figure 4-8. The remaining displays are illuminated pushbuttons for the transport control and are described in paragraph 4-24.

4-16. TAPE SPEED Switch Circuit. When the TAPE SPEED switch is in the LOW position, a ground is provided through the 'B' section of the switch which forward biases LED 101 (LOW) to illuminate it, and reverse biases LED 102 (HIGH) for no illumination. Setting the switch to the HIGH position reverse biases LED 101, extinguishing it, and provides a +27-volt source to LED 102 causing it to illuminate.

4-17. MASTER MONITOR Switch Circuit. With the MASTER MONITOR switch in the SINGLE position, a +27V appears on both sides of LED 97 (REPRO) and a ground appears on both sides of LED 98 (S/SYNC), resulting in no illumination of either diode. With the switch set to the S/SYNC position, +27V still appears on both sides on LED 97; however, the ground is removed from the anode side of LED 98 permitting +27 volts to appear at that anode through the limiting resistor, resulting in illumination of the LED. With the switch in the REPRO position, ground appears at both sides of LED 98 resulting in no illumination, but ground appears at the cathode side of LED 97 forward biasing it and causing illumination.



Figure 4-8. Control Panel Simplified Schematic, Channel 1 Shown

4-18. STANDBY MONITOR Switch Circuit.The status display for the STANDBY MONITOR switch operates in exactly the same manner as the LEDs for the TAPE SPEED switch described above, where the LEDs are provided with ground or +27 volts at the appropriate points to turn them on or off according to the position of the switch.

4-19. INPUT/REPRO/S/SYNC Switch Circuit (MASTER MONITOR switch set to SINGLE).With the INPUT/REPRO/S/SYNC switch set to INPUT, ground is applied at the junction of diodes CR3 and CR4 in the indicator logic assembly, which forward biases LED 49 (INPUT) causing illumination. With the switch set to S/SYNC, +27 volts is supplied through the switch 'B' contacts to LED 73 (S/SYNC) causing illumination.

4-20. READY/SAFE Switch Circuit. With the READY/SAFE switch in the READY position, ground is removed from the anode junction of LED 25 (READY), permitting source voltage to illuminate LED 25. When the record pulse (ground) occurs, a ground is reapplied through CR1 (in the switchboard and LED board assemblies) which causes LED 25 to extinguish and LED 1 (RECORD) to illuminate. This condition will exist as long as the record mode is operational since the record pulse signal is held at ground potential by a relay in the switcher module. When the record mode is operational, transistor Q1 in the indicator logic assembly is turned on and will provide a ground path for LED 49 (INPUT) causing it to illuminate, if the particular channel has been selected to the S/SYNC mode and the SYNC TRANSFER switch is not in REPRO.

4-21. Bias Amp Module

Schematic 4840249 shows the circuitry of the bias amp module. This amplifier receives a 150-kHz push-pull signal from the bias oscillator in the MM-1200 power supply. The bias amp module consists of two cascaded push-pull amplifiers. Operating power for the amplifiers is received via a transistor switch in the audio switcher module which supplies power to the bias amp module only when the system is in the record mode of operation. The signal from the bias oscillator is applied to the bases of transistors Q18 and Q19. Each transistor drives one half of the primary

winding of transformer T4. The push-pull signal taken from the center-tapped secondary of T4 is used to drive a second push-pull transistor/transformer stage (Q16, Q17, T3). Both amplifier stages operate at saturation level.

The single-ended signal is taken from the secondary of T3 and is routed through relay contacts in the audio switcher module and capacitor C40 (ERASE PEAK) to the erase head and through capacitor C39 and potentiometer R80 (BIAS ADJ) to the record head. The other side of the record head winding is connected through potentiometer R44 (BIAS CAL) to ground. Capacitor C40 (ERASE PEAK) is adjusted to resonate with the inductance of the erase head winding to provide maximum sinusoidal current through the winding. Potentiometer R80 (BIAS ADJ) is used to adjust the level of bias current, and potentiometer R44 (BIAS CAL) is used to calibrate the vu meter for bias level monitoring.

Resistors R83 and R87 are transistor-biasing resistors, and capacitors C42 and C45 are tuning capacitors which interact with their respective slug-tuned transformers (T3 and T4) to provide maximum signal coupling to the following stages. Potentiometer R92 is used to balance the circuit to provide minimum distortion. Resistor R86 and capacitors C44 and C43, and resistor R82 with capacitor C41 form decoupling filters to preclude signal interference between stages.

4-22. Record Amplifier

The record amplifier circuitry is contained on schematic 4840431, while the NAB and CCIR equalizers for 15/30 and 7-1/2/15 in/s are given on schematics 4840372 and 4840330, respectively. In the record amplifier, capacitor C24 couples the input audio signal to the base of emitter follower Q9, which provides a high input impedance and a low output impedance to the record equalizer circuit following. Capacitor C52 in each equalizer circuit couples the audio signal to potentiometer R108. The signal taken from the wiper of R108 in each equalizer circuit is routed to the input of an amplifier circuit in the reproduce amplifier module and is used for input monitoring. There are four equalizers that may be used in the record amplifier, depending on whether the 7-1/2/15-in/s or the

15/30-in/s speed is selected and upon whether an NAB or a CCIR equalization characteristic is desired. The components affecting the high-frequency portion of the equalization characteristic are listed in Table 4-2.

Low-frequency equalization is provided only for the 7-1/2- and 15-in/s speeds when used with NAB equalization characteristics. The low-frequency equalization capacitors (C25 and C27) are bypassed in the equalizer circuits for all other conditions.

Transistors Q10 and Q11 and associated circuitry form the low-speed and the high-speed equalizer amplifiers, respectively. The position of the TAPE SPEED switch determines which of these amplifiers is enabled and which is inhibited. To inhibit amplifier Q10, a high positive level is applied to pin 5 of the record amplifier. Resistor R57 and capacitor C26 delay the voltage rise at the junction of resistors R55 and R56. Delaying the voltage rise in this manner causes transistor Q10 to turn off slowly, avoiding switching transients. Conversely, amplifier Q10 is turned on when a low level is applied to pin 5. Amplifier Q11 is turned off and on in a similar manner by a high or low level voltage applied at pin 6 of the record amplifier.

Capacitor C30 couples the output of amplifier Q10 or Q11 to the base of transistor Q12. Transistors Q12 and Q13 and associated circuitry form two cascaded emitter-follower circuits to provide the high current required for the output amplifier

stage. The output driver stage consists of transistors Q14 and Q15 and their associated circuitry. Transistor Q15 is an active collector resistance for transistor Q14, allowing high recording current to be obtained. Capacitor C31 keeps signals at the base and emitter of Q15 in phase (i.e., bootstrapped), which causes the amplifier to have a high output impedance in the audio-frequency range. This high output impedance minimizes the effect of a variable load caused by changes in the record head impedance over the audio spectrum.

4-23. Reproduce Amplifier

The reproduce amplifier is shown on schematic 4840249 for 7-1/2/15 in/s and on schematic 4840431 for 15/30 in/s configuration. The 7-1/2/15 in/s and 15/30 in/s equalizers are given on schematics 4840330 and 4840372 respectively. Transformer T1 couples the audio output of the reproduce head or the record head (in Sel Sync mode) to the base of transistor Q1. Base bias for transistor Q1 is derived from the dc voltage developed across resistor R4. Capacitor C1 prevents signal degeneration. The output of amplifier Q1 is sent to the base of transistor Q2 which amplifies the signal and sends it to the base of transistor Q3. DC feedback is coupled from the collector of Q2 through resistors R3 and R2 to the base circuit of Q2. Capacitor C2 decouples the junction of R3 and R2 to signal ground, C4 prevents high frequency oscillation of stage Q2, and C5 minimizes signal degeneration in the emitter circuit of Q2. Collector voltage for Q1 and Q2 is switched on or off by transistor stage Q4. The turn on of Q4 is delayed by resistor R38

Table 4-2. High-Frequency Equalization Components

| PART NO. | SPEED | EQUALIZATION | COMPONENTS |
|------------|------------|--------------|---------------------|
| 4020269-01 | 7-1/2 in/s | NAB | C53, C57, R51, R109 |
| | 15 in/s | NAB | C54, R52 |
| 4020269-03 | 7-1/2 in/s | CCIR | C53, R51 |
| | 15 in/s | CCIR | C54, R52 |
| 4020269-06 | 15 in/s | CCIR | 11C53, R51 |
| | 30 in/s | CCIR | 11C54, R52 |
| 4020269-08 | 15 in/s | NAB | C53, R57, R51, R109 |
| | 30 in/s | NAB | C54, R52 |

and capacitor C8 when power is applied to the reproduce amplifier. Consequently, amplifiers Q1 and Q2 are brought into operation slowly when power is first applied, minimizing transient noise in the audio output and minimizing violent movement of the vu meter needle.

Emitter follower Q3 provides the low impedance drive for the reproduce equalizer and the base circuit of transistor Q5. The reproduce equalizer is situated in a feedback path that interconnects the emitter of Q3 and the emitter of Q1. High-speed or low-speed equalization is selected by control voltages that are applied to diodes CR1 and CR2. These voltages are controlled by the TAPE SPEED switch. When a high voltage is applied to pin M and a low voltage to pin N of the reproduce amplifier, diode CR1 is forward biased and CR2 is reverse biased. Thus, an audio feedback signal is taken from the emitter of transistor Q3 and routed through C6, CR1 and C3 in the reproduce amplifier and R104, R103, R102, C50, and R101 in the equalizer circuit back to the emitter of transistor Q1. Conversely, when diode CR1 is turned off and diode CR2 is turned on by reversal of the voltages on pins M and N of the reproduce amplifier, the feedback path is via C6, CR2 and C17 in the reproduce amplifier circuitry and R107, R106, C51, R105, and R101 in the equalizer circuitry back to the emitter of transistor Q1. The equalizer circuit is a broadband circuit and is used to provide equalization for all the applicable characteristic requirements at any speed.

The output of emitter follower Q3 is coupled through capacitor C7, out of the reproduce amplifier through pin A, through the switcher module, back into the reproduce amplifier through pin D, and through capacitor C11 to the base of transistor Q5. Capacitor C10 attenuates unwanted high frequencies, and capacitor C12 is used for decoupling of the base bias network of transistor Q5. The signal is amplified through transistor Q5 and is coupled directly to the base of transistor Q6, which in turn drives complementary amplifiers Q7/Q8. Capacitor C14 enhances the dc voltage (hence current) available to the base of transistor Q8, allowing the output signal at pin 5 of the reproduce amplifier to swing to almost 39 volts without clipping. Resistor R25 couples feedback from the signal output line to the emitter of

transistor Q5. Resistors R25 and R26 set the overall ac gain of the amplifier formed by transistors Q5, Q6, Q7, and Q8 and their associated circuitry.

4-24. TRANSPORT CONTROL

4-25. Stop and Braking Logic

The stop logic circuits include the stop memory latches, brake latch and brake release circuits; record stop, end-of-tape (EOT), and dynamic braking circuits. These are shown in the simplified schematic of Figure 4-9. In the stop mode, the mechanical reel brakes are automatically engaged but may be released for editing by pressing the LIFT DEFEAT button. The stop command from any motion first initiates the dynamic braking. The dynamic braking system reverses power to the reel motors to bring the reels to a smooth stop under constant tape tension. Once motion ceases, the mechanical brakes are engaged and the STOP indicator is lighted. The record stop feature allows the record mode to be terminated while the motion continues uninterrupted. The end-of-tape logic initiates the normal stop sequence, but also reduces the drive to the reel motors and engages the reel brakes immediately.

4-26. Initial Turn On. At initial turn on, the transport is forced into the stop mode by the time constant of R43 and C27, which is longer than that for the other control commands. The low at A13-3 is inverted and ANDed with the A7-5 high to produce the low set command to the stop latch A7-8/A14-6. The resulting high at A7-8 indicates stop. (Any motion command — PLAY, FAST FWD, REWIND — at the inputs of A14-6 will reset the latch for a low at A7-8, indicating motion.) The stop sequence is controlled by the stop mode latch A3-11/A3-8. This latch is reset by the low MOTION command from A7-11, which results when both inputs A7-12 and 13 from the true direction flip-flop (see paragraph 4-45) are high. Since there is no motion at initial turn on, the stop mode latch will be reset; A3-8 will be high and A3-11 low. The low at A3-11 sets the stop tension circuits (see Tension Servo, paragraph 4-37). The high from A13-4 is ANDed with the high from A3-8 to produce the low reset command to the

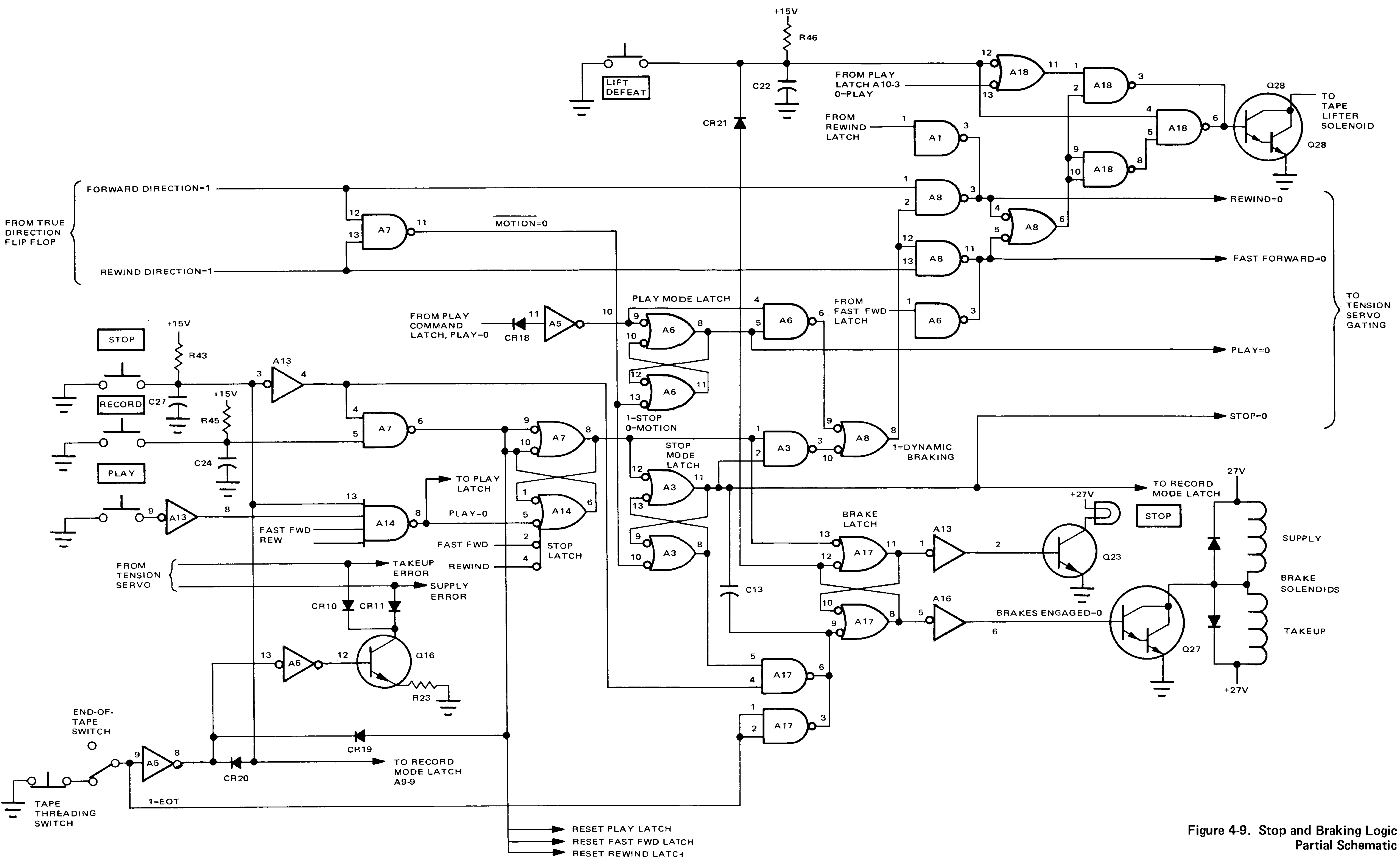

Figure 4-9. Stop and Braking Logic Partial Schematic

brake latch A17-11/A17-8. The high at A17-8 is inverted through A16-6, which turns Q27 off, releasing the solenoid and engaging the brakes. The low at A17-11 is inverted through A13-2, which turns Q23 on, lighting the STOP indicator. Note that the brakes are engaged by the low at A17-9 which is available through C13 for any MOTION command as well as from A17-3, the EOT gate (see paragraph 4-28).

4-27. Break Release. Any of the motion commands (PLAY, FAST FWD, REWIND) at the input to the stop latch A14-6 section resets the stop latch for a low at A7-8. This low is connected to A17-13 which sets the brake latch which in turn disengages the brakes and turns off the STOP indicator. The brakes may be released for editing by pressing the LIFT DEFEAT button momentarily. The low from the switch through CR21 sets the brake latch. The high at A17-11 is inverted to turn the STOP indicator off, while the low at A17-8 is inverted to turn Q27 on, which operates the reel brake solenoids to release the brakes. Since only the brake latch is reset by the LIFT DEFEAT brake release, the tape stop tensions remain on. When the LIFT DEFEAT button is used to release the brakes the lifter is also defeated as long as the button is held down. Any new motion command may be entered from the edit mode, but if the brakes are to be re-engaged, the STOP button must be pressed. If the transport is in the stop mode, A3-8 is high; and when the STOP button is depressed, A17-6 goes low and resets the brake latch just as an A3-11 low would. Capacitor C13 provides a transition low when A3-11 is latched at stop but allows the brake latch to receive new set commands from A17-6 or A17-3.

4-28. End-of-Tape (EOT). The EOT command when the switch opens is a high at A5-9. This high is inverted by A17-3 to set the brake latch, engaging the brakes. At the same time, the low from A5-8 is inverted through A5-12 turning Q16 on, which reduces the error drive level to the takeup and supply motor drive amplifiers. The low through CR20 from A5-8 inhibits any play command and resets the record mode latch. If the RECORD switch is open, the low at A13-3 is inverted and ANDed at A7-6 to provide the low set command to the stop latch A7-8/A14-6. In some remote systems, the remote RECORD line is held

low, inhibiting A7-6. In this case, the low through CR19 supplies the set command to the stop latch. The low through CR19 also resets the play, fast forward, and rewind latches as would a normal stop command.

4-29. Record Stop. The record stop function allows the record mode to be terminated while maintaining the play mode. If the RECORD button is held down while the STOP button is pressed momentarily, the low at A7-5 inhibits the stop command from A13-4. Since the tape is in motion, A3-8 is low, which inhibits the high at A17-4. The stop latches remain in their reset condition. The low from the STOP button resets the record mode latch A10-8/A9-8, which latches the record hold control line high (record mode off).

4-30. Dynamic Braking. The dynamic braking system, when gated on, applies the opposite direction drive to the reel motors to bring the reels to a smooth stop. Dynamic braking occurs for motion to STOP or motion to PLAY commands. Note in Figure 4-9 that a low level at either A8-3 or A8-11 from the rewind or fast forward latches turns on the takeup or supply tension circuits respectively; and that the input to A8-1 will be high when the tape is moving forward, while A8-13 will be low. The input to A8-1 will be high during play (or record); however, the play tensions are set by the low from A6-8. A high at A8-2/A8-12 will enable the opposite direction tension. If, for example, the tape is moving forward when A8-2/A8-12 go high, A8-3 will go low, enabling the rewind tensions. The rewind tension circuits reduce the drive level to the takeup reel and increase the drive to the supply reel.

Gate A8-8 is the dynamic braking control gate. Normally A8-8 is low and only goes high when a stop or play command is entered. A stop or play command will reset the fast forward or rewind latches if either of those modes had been engaged. This allows the tension to be selected by the high from A8-8.

If PLAY is pressed, A5-10/A6-4 goes high. Since the previous command was not play, A5-10 would have been low to set the play mode latch A6-8/A6-11 for a high at A6-5. Gate A6-6 goes low then

at the play command, making A8-8 high. The opposite direction drive is enabled, bringing the reels to a smooth stop. Once the motion has ceased, MOTION resets the play mode latch A6-8/A6-11 with A6-8 low, which engages the play tension (see paragraph 4-33 for details of the other elements of the play sequence). The dynamic braking gate A8-8 is also cleared when the MOTION signal resets the play mode latch.

If STOP is entered from motion, A7-8/A3-1 go high. Since the previous motion command had reset the stop latch A3-11/A3-8, A3-11/A3-1 will be high. Gate A3-3 goes low, making A8-8 high. As described for play, the reel drive is reversed to bring the reels to a smooth stop. When motion ceases, the stop mode latch is reset by MOTION which clears the dynamic braking gate A8-8 by the high at A3-3.

When switching between FAST FWD and REWIND, the transport does not enter the stop mode. However, the low at A6-3 or A1-3 from the respective fast forward or rewind latches will be reversed, which engages the opposite tension servo drive levels to the reel motors. The tape will remain under constant tension as it slows toward stop and reverses direction. At the instant of direction change, A7-11 goes low (MOTION). The MOTION will not reset the stop mode latch since the fast forward or rewind command has set the stop latch A7-8/A14-6 for A7-8/A3-12 low (the motion state), thus inhibiting the stop mode latch from being set by MOTION.

4-31. Tape Lifter Logic

The tape lifter is automatically operated by the mode commands for the tape to be lifted from the heads during fast forward or rewind and released during play (or record) or stop. The LIFT DEFEAT switch, when pressed, moves the lifter in the opposite direction to that automatically selected. The tape lift circuit is shown in Figure 4-9.

In fast forward or rewind modes, either A8-5 or A8-4 respectively will be low, making A8-6 high. This high is inverted by A18-8, which produces a high at A18-6. If A18-3 is not low, Q28 will turn on, which engages the solenoid to move the tape away from the heads.

If STOP is pressed during the fast forward or rewind modes, A8-8 goes high initiating the dynamic braking sequence, which makes A8-5 or A8-4 low (depending on the direction). Just as in fast forward or rewind, A8-6 is high engaging the tape lifter through A18-8 and A18-6. When the transport comes to a stop, the lifter is disengaged when MOTION resets the stop mode and play mode latches. With the low at A6-5 from A6-8, A6-6 goes high. The low at A3-2 and A3-11 makes A3-3 high. The low from A8-8 then forces both A8-3 and A8-11 high. When A8-6 goes low, A18-8 goes high; and if the LIFT DEFEAT button is not depressed, A18-6 then will go low turning off Q28 to disengage the lift.

If STOP is pressed during the play mode, the play mode latch and the stop mode latch are reset by MOTION for lows at A6-5 and A3-2, making A6-6 and A3-3 high. As in stop, A8-8 then is low making A8-3 and A8-11 high. The subsequent low at A8-6 makes A18-8 high. This high is ANDed with the high at A18-4 (if LIFT DEFEAT is not depressed) to make A18-6 low. This turns off Q28, which disengages the tape lifter. To keep the lift disengaged during a dynamic braking sequence (PLAY to STOP) when A8-8 goes high, the low from the play latch at A18-13 hold A18-11 high. Then, when A8-8 goes high, A8-3 goes low (since the play direction is forward). Gate A8-6 goes high and is ANDed with the high from A18-11 to maintain the low at the base of Q28 keeping the lift disengaged until the dynamic braking sequence is ended by MOTION.

4-32. Lift Defeat Logic

The automatic tape lift function is defeated by holding the LIFT DEFEAT button depressed. If the lift is engaged, as in fast forward or rewind, A18-3 and A18-6 must be high, which turns Q28 on. A low at A18-3 then will disengage the lift. When A18-12 goes low by pressing the LIFT DEFEAT switch, A18-11 goes high. During fast forward or rewind, A18-2 is high. The resulting low from A18-3 then shuts off Q28, releasing the lift.

In play or stop, Q28 is turned off by the low at A18-6; the lift is not engaged. When LIFT DEFEAT button is pressed, A18-4 goes low, making

A18-6 high which turns Q28 on. A18-3 will be high in play or stop since A18-2 is low. By eliminating the connection between A18-12 and A18-4, the lift function is defeated during fast forward or rewind. This should be done when using control track information off-tape, since data is also read in the fast modes.

4-33. Play Logic

The play logic is shown in the simplified schematic of Figure 4-10. A low PLAY command at A13-9 is inverted to a high at A14-9. Gate A14-8 controls the priority for a play command. Any low from STOP, FAST FWD or REWIND will inhibit the play command at A14-8. If the gate is not inhibited, a low at A14-8 resets the stop latch (not shown) for a motion mode, which in turn sets the stop mode latch so that dynamic braking will occur when the STOP button is later pressed (see paragraph 4-30, Figure 4-9). The reset stop latch also sets the brake latch, releasing the reel brake (see paragraph 4-25, Figure 4-9).

The low from A14-8 sets the play command latch A3-6/A9-6 for A9-6 low. This low is inverted by A5-6 to turn Q19 on, lighting the PLAY indicator. Diode CR18 conducts, making A5-11 low and A5-10 high. Inverter A5-10 is always low except when the play latch is set, thereby holding the play mode latch A6-8/A6-11 in a set state. In its set state, the high at A6-8 is inverted by A15-12 to turn off Q26 which disengages the pinch roller. The A6-8 high is also inverted by A19-3 which disables the capstan servo. Once the forcing low from A5-10 is removed by the low from the play command latch through CR18, the play mode latch A6-8/A6-11 may be reset by the MOTION low from the true direction flip flop (refer to paragraph 4-45). This assures that the capstan and pinch roller will be smoothly engaged when the tape is at rest (if only for a moment during a motion to play dynamic braking sequence). If the transport had been stopped when the play command was entered, the MOTION low will immediately reset the play mode latch. When the play mode latch is reset, the low at A6-8 enables the pinch roller and the capstan servo through inversion by A15-11 and A19-3, respectively. At the same time, the low at A6-8 sets the play tension in the tension servo system (refer to paragraph

4-37). Also, the A6-8 low sets latch A10-6/A10-3 for a low at A10-3 which disengages the tape lift (see paragraph 4-31).

If the tape is in motion when the play command is entered, the dynamic braking sequence will be initiated to bring the tape to stop before the play mode begins. When the transport is in some mode other than play, A5-11 is high, A5-10 low, and the play mode latch A6-8/A6-11 will be in a reset state with A6-8 high. When A5-11 goes low at PLAY, A5-10 goes high. This high is ANDed with the high at A6-5 making A6-6 low. The low at A6-6 makes A8-8 high, which initiates the dynamic braking sequence (see paragraph 4-30). When motion ceases, MOTION resets the play mode latch making A6-8 low. This low at A6-5 makes A6-6 high, canceling the dynamic braking as the play mechanisms are engaged.

4-34. Record Logic

The record logic enables the basic transport play motions while providing record control commands to the signal switching. To provide time for bias decay, the tape motion is continued for a period of 0.2 second after the record mode is terminated by stop, fast forward, or rewind commands. The record logic is included with the play logic in the simplified schematic of Figure 4-10.

The PLAY and RECORD buttons are held down simultaneously. The normal play logic conditions enable the record initiation. A low at A14-8 which sets the play command latch and resets the stop, fast forward, and rewind latches also is inverted high by A13-10 to enable gate A15-8. Then when the low from the RECORD button is inverted high by A16-8, A15-8 goes low. This low is inverted by A16-4 making A15-5 high. If the transport is in play, A6-8 of the play mode latch will be low, making A15-3/A15-4 high which enables the high from A16-4 to make A15-6 low. The low at A15-6 (which sets the record mode latch A10-8/A9-8) is inverted by A16-12 to turn the record pulse driver on for as long as the RECORD and PLAY buttons are held down. When the record mode latch is set, the low at A9-8 is inverted by A16-2 to turn on Q20, which lights the RECORD indicator, and also is inverted by

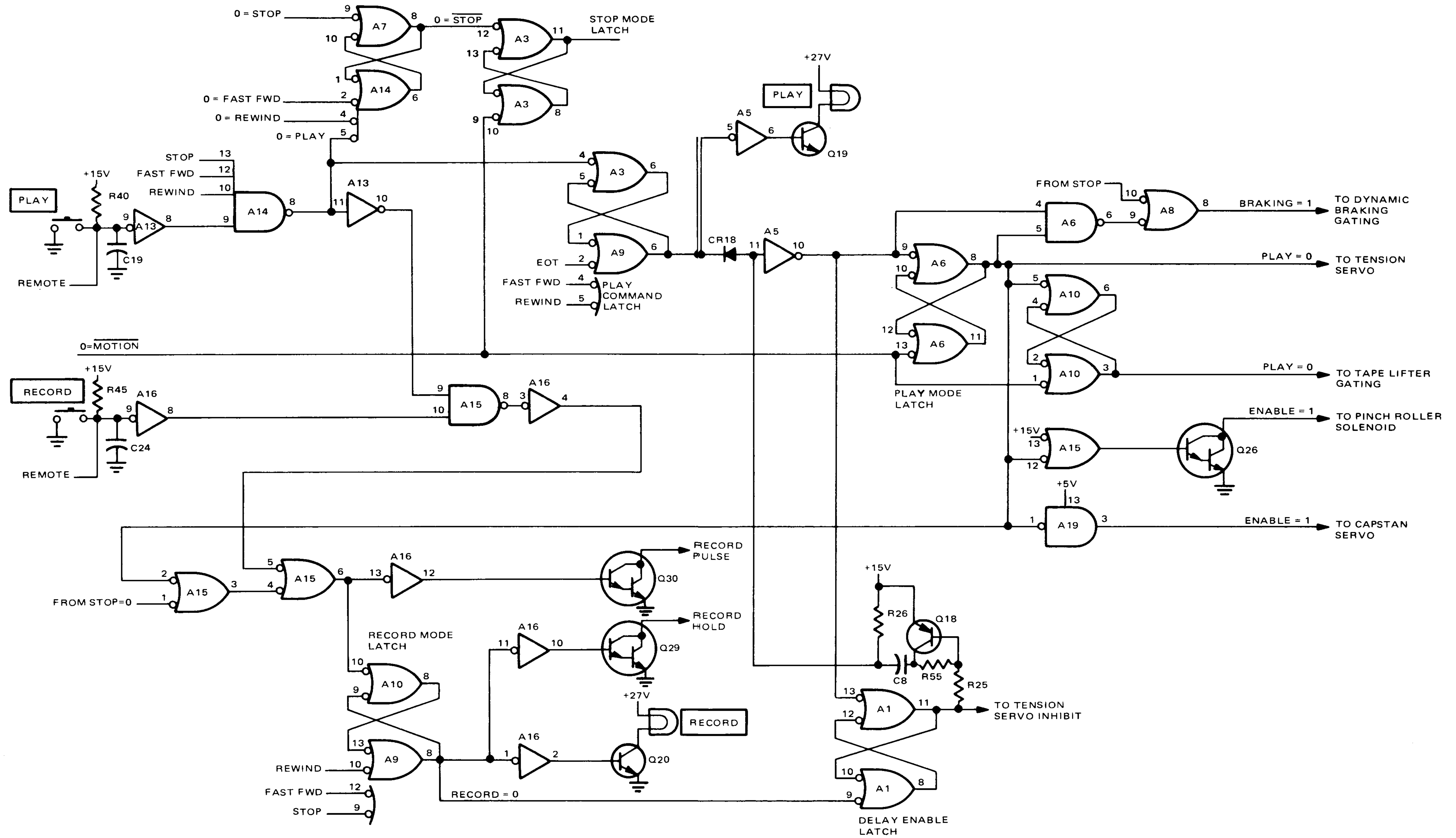

Figure 4-10. Play and Record Logic Partial Schematic

A16-10 to turn on record hold line driver Q29. The record pulse and record hold lines operate the record switching in the audio switching module.

If STOP, REWIND, or FAST FWD are pressed during the record mode, the Q18 delay circuit prevents the tape from stopping or changing speed for 0.2 second, which provides time for the record bias to decay. The delay enable latch is reset by the low from A9-8 for a low at A1-11. This low turns on the Q18 delay circuit and inhibits the rewind and fast forward latch outputs from controlling the tension servo, and also inhibits the dynamic braking gates. Neither the fast commands nor the dynamic braking can operate until the delay times out at the end of the record mode.

The play command latch A9-6 low provides a current path to charge C8 when Q18 is turned on by the A1-11 low. When a fast forward, rewind, or stop command is entered, A9-6 goes high. The low current path for C8 is removed and C8 discharges. When the high threshold of A5-11 is reached (0.2 second), A5-10 goes low which sets the play mode latch. This releases the pinch roller and disables the capstan servo. Also, when the delay times out and A5-10 goes low, the delay enable latch is set for a high at A1-11, which releases the tension servo for normal motion-to-stop dynamic braking or fast motion control.

4-35. Fast Forward Logic

The fast forward logic is shown in Figure 4-11. A low from the FAST FWD button sets the fast forward latch A1-6/A2-6 for a high at A1-6 and a low at A2-6. The low from the switch also resets the rewind, record, play and stop latches. The connection to A14-12 inhibits play commands through A14-8, the play priority gate (see paragraph 4-33). When the fast forward latch is set, the low at A2-6 is inverted through A13-12 to turn Q24 on which lights the FAST FWD indicator.

If the transport is in the record mode when the FAST FWD button is pressed, the high from latch output A1-6 is inhibited at gate A6-2 by the low from delay enable latch A1-11/A1-8. The fast forward mode cannot be entered until the record stop delay times out and the delay enable latch is set for a high at A1-11 which allows A6-3 to go low.

In any other mode A1-11 will be high, enabling A6-3, and the fast forward latch A1-6 high output will make A6-3 low. The low at A6-3 gates the forward tension control circuits of the tension servo system (refer to paragraph 4-37). At the same time, the low at A6-3 is gated through A8-6 to engage the tape lift (see paragraph 4-31).

4-36. Rewind Logic

The rewind logic is shown in Figure 4-11. When the REWIND button is pressed, the rewind latch A7-3/A2-8 is reset for A7-3 high and A2-8 low. At the same time, the input low resets the stop, play, record, and fast forward latches and also inhibits any play command through A14-8.

When the rewind latch is set, the low at A2-8 is inverted by A13-6 to turn Q25 on, which lights the REWIND indicator. Also, the low at A2-8 is inverted high through A10-11 which makes A1-3 low. (If the transport is not in record, see *Fast Forward Logic* and the *Record Logic*, paragraphs 4-34 and 4-35.) The low at A1-3 enables the rewind tension circuits of the tension servo (refer to paragraph 4-37) and engages the tape lift through A8-6.

4-37. Tape Tension Control and Servo

The tape tension control and servo circuits are shown in the simplified schematic of Figure 4-12. Each reel is continuously driven in a single direction: takeup — forward, supply — reverse. The tension servo supplies holdback error levels to one and drive error levels to the other, reversing the error levels to reverse the direction. During stop and each of the tape motion modes, the tape is held at constant tension by the tension servo. The servo operating point is set for each mode by gating specific gain control circuits into the servo loop. The following paragraphs describe the operation of the servo in each of the transport modes.

4-38. Tension Error Amplifier. The error signals developed by photo cells PC1 and PC2 of the tension sensor assembly are coupled to the input of a two-stage tension error amplifier consisting of amplifiers A12 and A11. Amplifier gain is determined by the setting of potentiometer R34.

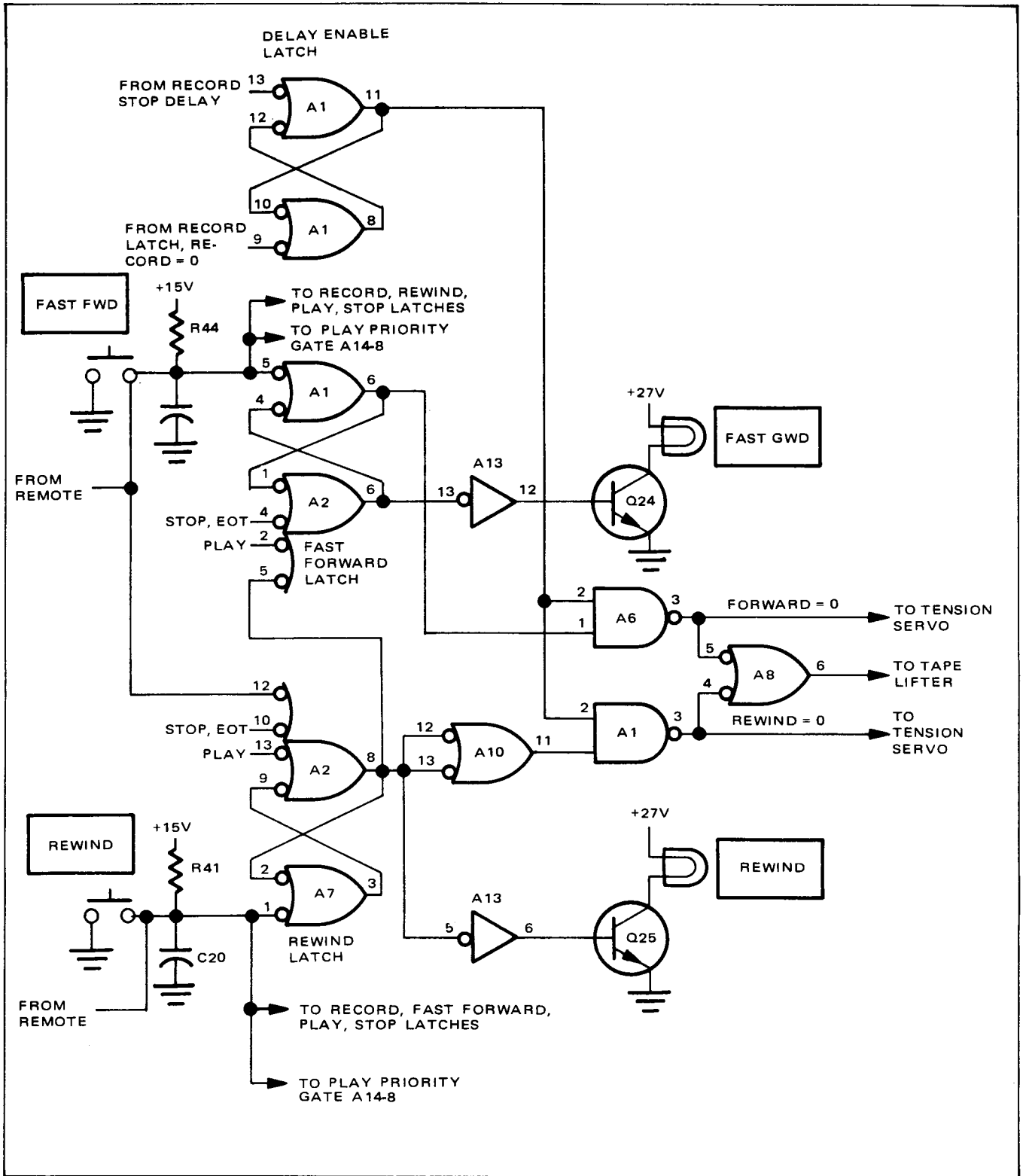

Figure 4-11. Fast Forward and Rewind Logic

Potentiometers R1 through R4 and R10 are used to set the quiescent operating point of the amplifier. Potentiometer R34 is always connected into the amplifier circuit, but potentiometers R1 through R4 and R10 are switched in and out of the circuit in accordance with tape tension requirements of each operating mode. The output of the error amplifier is coupled through level shifter VR1/R30 to the bases of transistor amplifiers Q14 and Q15. Amplifiers Q14 and Q15 drive error signal amplifiers in the motor drive amplifier (MDA) assembly (refer to paragraph 4-47). The gain of Q14 is determined by potentiometer R8; the Q15 gain is determined by R7. Potentiometer R8 is switched in for reverse motion, R7 for forward motion.

4-39. Play/Record Mode. In the play/record mode, the tension servo is compensated for one- or two-inch tape systems as well as for high and low speed. This assures that the initial tape acceleration will not cause a frequency shift of the signal as the reel motors reach normal speed. The tension select line is held low for two-inch tape by a jumper in the two-inch head assembly which does not exist in the one-inch head assembly. The high and low speed lines are controlled from the TAPE SPEED switch.

When the play/record mode is selected, the play tension low at the input is inverted by A5-4, A4-10, and A4-8. Transistors Q13 and Q1 (or Q4 depending on whether one- or two-inch tape is used) are turned on immediately, but Q9 (or Q10 depending on tape width) turn-on by A4-8 is delayed by the time constant of R14 or R15 and C1/C2.

The gain of the tension error amplifier which supplies a varying drive to the supply MDA for one-inch systems is established by R10 when Q1 and Q2 conduct. The high on the tension select line for one-inch systems allows Q2 to turn on, providing a current path for Q1 while holding Q4 off. For two-inch systems, Q1/Q2 turns off and Q4 turns on. Resistor R2 then sets the gain of the tension error amplifier.

The gain of the supply error drive amplifier Q14 is set when Q13 is turned on by the high at A4-10. Potentiometer R7 controls the basic supply reel error level for forward motion as well as stop.

When the A4-8 goes high, either Q9 (for two-inch systems) or Q10 (for one-inch systems) supplies constant current to the error amplifier in the takeup MDA. For one-inch systems, the tension select line is high which turns on Q12 to provide a current path for Q10. The play takeup gain is set by R11. For two-inch systems, the tension select line is low which allows Q9 to conduct. Potentiometer R5 then sets the play takeup gain of the MDA.

When the play mode is engaged and A4-8 goes high, Q9 or Q10 is prevented from turning on until C1 or the parallel combination of C1/C2 is charged. This provides a boost torque for initial acceleration of the reels, which is gradually removed as the capacitor(s) charge and Q9 or Q10 is turned on to the normal operating point. The boost torque is a function of the tape width and tape speed. At high speed and two-inch tape, for example, C1 and C2 are in parallel and Q6 conducts. Thus R14 controls the time that initial torque is applied to the takeup reel motor. At low speed and one-inch tape, Q7 conducts but C2 is not in the circuit resulting in the much shorter time constant of R15 and C1.

4-40. Rewind Mode. When the rewind mode is selected or the dynamic braking logic automatically selects rewind tension, a logic low is furnished to inverters A4-4 and A5-2. The resulting highs produced by these inverters turn on transistors Q17 and Q8 respectively. Turning on Q17 enables and sets the gain for amplifier Q15, and turning on Q8 sets the gain of the tension error amplifier. Because amplifier Q14 is not enabled, no drive is applied to the error amplifier in the supply MDA. The supply MDA then supplies full driving power to the supply reel motor, causing it to develop full torque. Consequently, the tape is rapidly wound onto the supply reel. Proper tape tension is maintained by the error signal from the tension sensor assembly. This signal is amplified by the tension error amplifier and amplifier Q15 and used to control the takeup MDA, which in turn controls the holdback torque of the takeup reel motor.

4-41. Fast Forward. When the fast forward mode is selected or the dynamic braking logic automatically selects fast forward tension, a low is

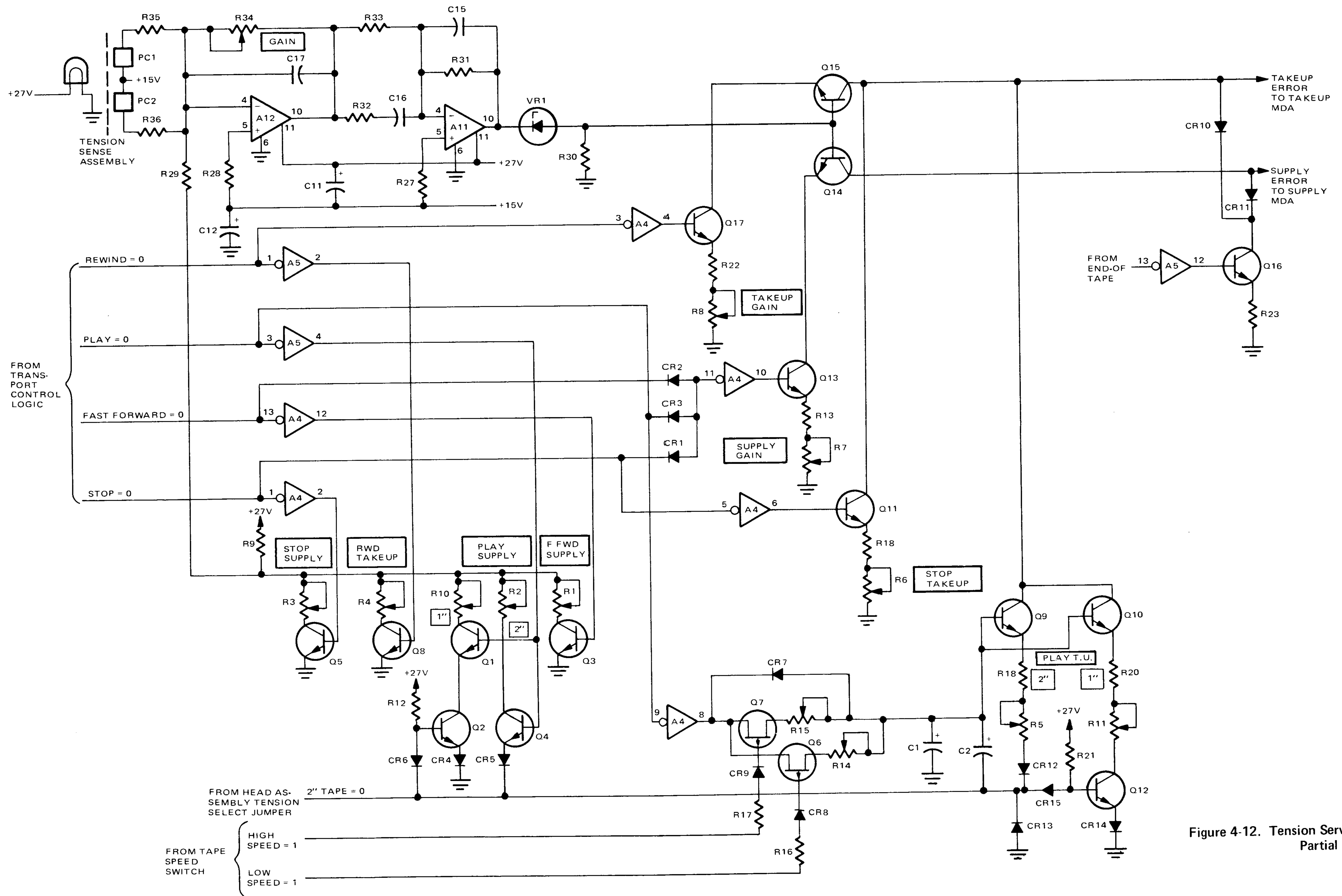

Figure 4-12. Tension Servo Circuits Partial Schematic

furnished to inverters A4-10 and A4-12. The resulting high produced by these inverters turn on transistors Q13 and Q3 respectively. Turning on Q13 enables and sets the gain of amplifier Q14, and turning on Q3 sets the gain of the tension error amplifier. Because amplifier Q15 is not enabled, no drive is applied to the error amplifier in the takeup MDA. The takeup MDA then supplies full driving power to the takeup reel motor, causing it to develop full torque. Consequently, the tape is rapidly wound onto the takeup reel. Proper tape tension is maintained by the error signal from the tension sensor assembly. This signal is amplified by the tension error amplifier and amplifier Q14 and is used to control the supply MDA, which in turn controls the holdback torque of the supply reel motor.

4-42. Stop. When the stop mode is selected and the tape has ceased motion, the stop tension line to inverters A4-6, A4-10, and A4-2 is low. The resulting highs turn on transistors Q11, Q13, and Q5 respectively. With Q11 turned on, a constant current is supplied to the takeup MDA which provides constant drive. Turning on Q13 sets the gain for Q14 in the supply error line, and turning on Q5 sets the gain of the tension error amplifier. The error signal developed by the tension error assembly is amplified by the tension error drive amplifier Q14 and the supply amplifier, providing sufficient drive to the supply reel motor to offset the torque of the takeup reel motor to hold the tape at rest under normal tension.

4-43. End-of-Tape. When the tape breaks or the supply is exhausted, the end-of-tape logic furnishes a low to inverter A5-12. Transistor Q16 is turned on by the resulting high providing equal, low drive levels to both MDAs to prevent reel motion.

4-44. Search-to-Cue and Tape Timer

The search-to-cue and tape timer electronics are contained on the same printed wiring assembly. However, other than a common source of tachometer signals, clock signals, and a speed select gate, the search-to-cue and the tape timer electronics are entirely separate and have no dependence on each other.

4-45. Tape Timer. When a tape transport motion mode is entered, tape motion causes the tape timer idler to rotate. Attached to the timer idler is a tachometer wheel on which is a set of alternate clear and opaque segments. There are two photocouplers mounted adjacent to the tachometer wheel such that they are 90° out of phase with each other. Figure 4-13 shows a simplified block diagram of the timer portion of the search-to-cue and tape timer electronics.

The output of the photocouplers is preamplified and sent through the tachometer amplifiers and filters such that the output of one of the photocouplers is clocked through true direction flip-flop, A5, by the output of the other photocoupler. Therefore, if the tape is moving in one direction, all logic highs are clocked through the direction latch. If the tape is moving in the opposite direction, all logic lows are clocked through the direction latch. A corresponding logic high or logic low output from the true direction flip-flop to EXCLUSIVE OR gate A21 is representative of tape direction. Outputs from the true direction flip-flop are also sent to the motion sense circuitry of gates A2-6/8 and transistors Q3 and Q4 which, in turn, present a logic low or high to the transport control electronics, depending on the direction of tape motion or lack of motion.

An output is taken from the tachometer amplifier (A1-4) and is sent through a divider (A3) which can be adjusted for different divide factors depending on tape speed. The tachometer signal is then sent to the synchronized tach circuitry. The output signal from the clock generator is used throughout the timer for various functions. The tachometer signal is received by the 'D' input of the synchronized tach circuit and is clocked through by the clock signal so that the output signals are one clock pulse in width. The retimed tach signals are sent to the preset input of the tachometer memory circuit (A10-5) where they are stored until required by NAND gate A15-6. The clock pulse also operates a shift register (A6/A7) which has eight outputs. The register is so arranged that as it is cycled by the incoming clock signal, all its outputs are logic high except one. The logic low appears at a different output at every clock pulse. When the logic low appears at the A7-13 output, it enables NAND gate A15-6 which then

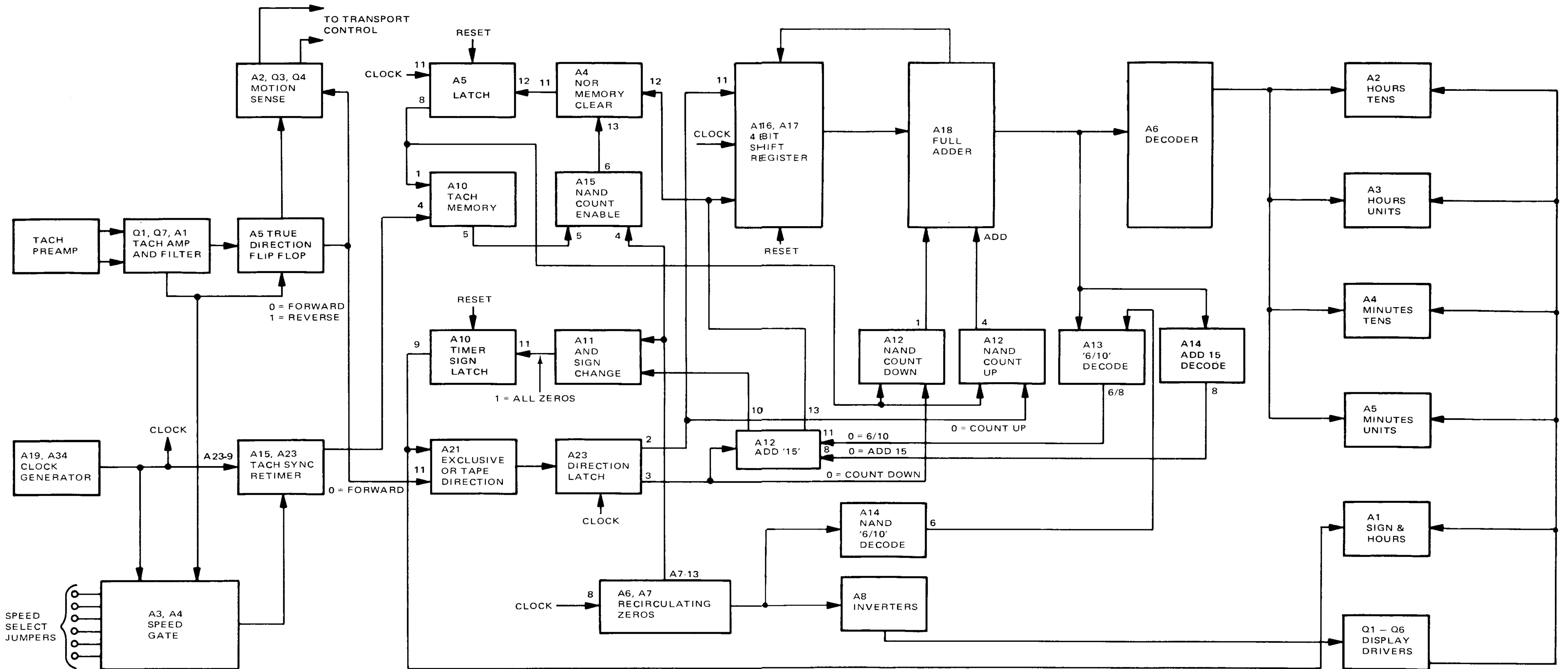

Figure 4-13. Tape Timer Block Diagram

enables NOR gate A4-11. The output of NOR gate A4-11 goes to latch A5-8 and that signal is clocked through on the next clock pulse. When the signal is checked through latch A5-8, it clears the tach memory and puts an enabling signal on the inputs of NAND gates A12-1/4. Depending on the state of EXCLUSIVE OR gate A21-11, as determined by the direction signal from direction latch, A23-2/3; either gate A12-1 (count down) or A12-4 (count up) is enabled.

In the forward direction, NAND gate A12-4 will add '1' to the full adder, increasing the count by one for each tach pulse. In the reverse direction, a '15' (binary 1111) is added to the full adder A18 by recirculating the full adder output into the shift register when enabled by the ADD 15 gate A14-8 and gate A12-10/13. Also in the count up direction, gate A13-6 or A13-8 is enabled by the output of the full adder depending on whether a binary 6 or a binary 10 is present.

If the 6 DECODER gate A13-6 is enabled by a 6 (binary 0110) appearing at its input, it enables gate A12-13 which, in turn, enables NOR gate A4-11 which presents a logic high at latch A5 input in the same manner as tach pulses. Then, when the next clock pulse occurs, that logic high stored at the input of latch A5 is clocked through to NAND gate A12-4 and a 1 is added to the number stored in the full adder (A18).

The same procedure occurs when a 10 count is detected by 10 DECODER gate A13-8. This action causes the shift registers A16 and A18 to count in modulus 6 or 10 and carry a 1 to the next significant digit.

Also when counting down, when all the units of hours, minutes, and seconds are at zero, AND gate A11-1 receives an 'all zeros' signal from gate A12-10 which complements the timer sign latch A10-9 which causes direction latch A23-2/3 to change state. The timer sign +LED is enabled or disabled by the state of latch A10-9. The timer LEDs are driven by the display drivers, Q1 through Q6, which are enabled by the pulses from the recirculating zeros shift register A6/A7.

4-46. Search-to-Cue. Refer to Figure 4-14. When a transport mode is entered, an output from the speed change divider A3 (described in paragraph 4-45) is sent to a binary counter consisting of A9, A20, A26, and A32. The counter simply counts tach pulses until cleared by a cue signal. This same cue signal also clears counter sign flip-flop A29-5, which places a logic low at one input of EXCLUSIVE OR gate A21-3. When a tape forward mode is selected after depressing the CUE pushbutton, a forward motion signal (logic low) is sent from direction sensing circuitry in the timer to the other input of EXCLUSIVE OR gate A21-3. Since a logic low now appears at both inputs of A21-3, it outputs a logic low back to the counter circuitry which enables the counter to count up when tach pulses are received.

Clearing counter sign flip-flop A29-5 also places a logic low at one input of EXCLUSIVE OR gate A21-8. The other input to A21-8 will come from AND gate A27-6 when enabled from the velocity and distance detectors A28-7/8/14. The output of EXCLUSIVE OR gate A21-8 has no effect until a search command is generated.

As the tape motion continues in the forward direction, the binary counter starts to fill. The counter output signals are sensed by a digital-to-analog converter consisting of differential amplifier A28-1 and its associated resistors. The D/A converter outputs an analog voltage that increases in value as the tape moves farther away from the counter zero (CUE) point in either the forward or reverse direction. The voltage from the D/A converter is sensed by variable gain differential amplifier A28-7, which is used as a distance detector since its output voltage is a function of the counter output.

If the tape has moved forward of the CUE point or is going in that direction when the SEARCH pushbutton is pressed, a logic low is sent to search memory A30-4 which resets and enables NAND gates A24-3 and A24-6. The low output of EXCLUSIVE OR gate A21-8 inhibits NAND gate A24-3 and, being inverted through EXCLUSIVE OR gate A21-6, enables NAND gate A24-6 which sends a rewind command to the transport control causing the transport to go into the rewind mode. When the tape rewinds, the counter counts down since the direction sense signal from gate A5-6 is

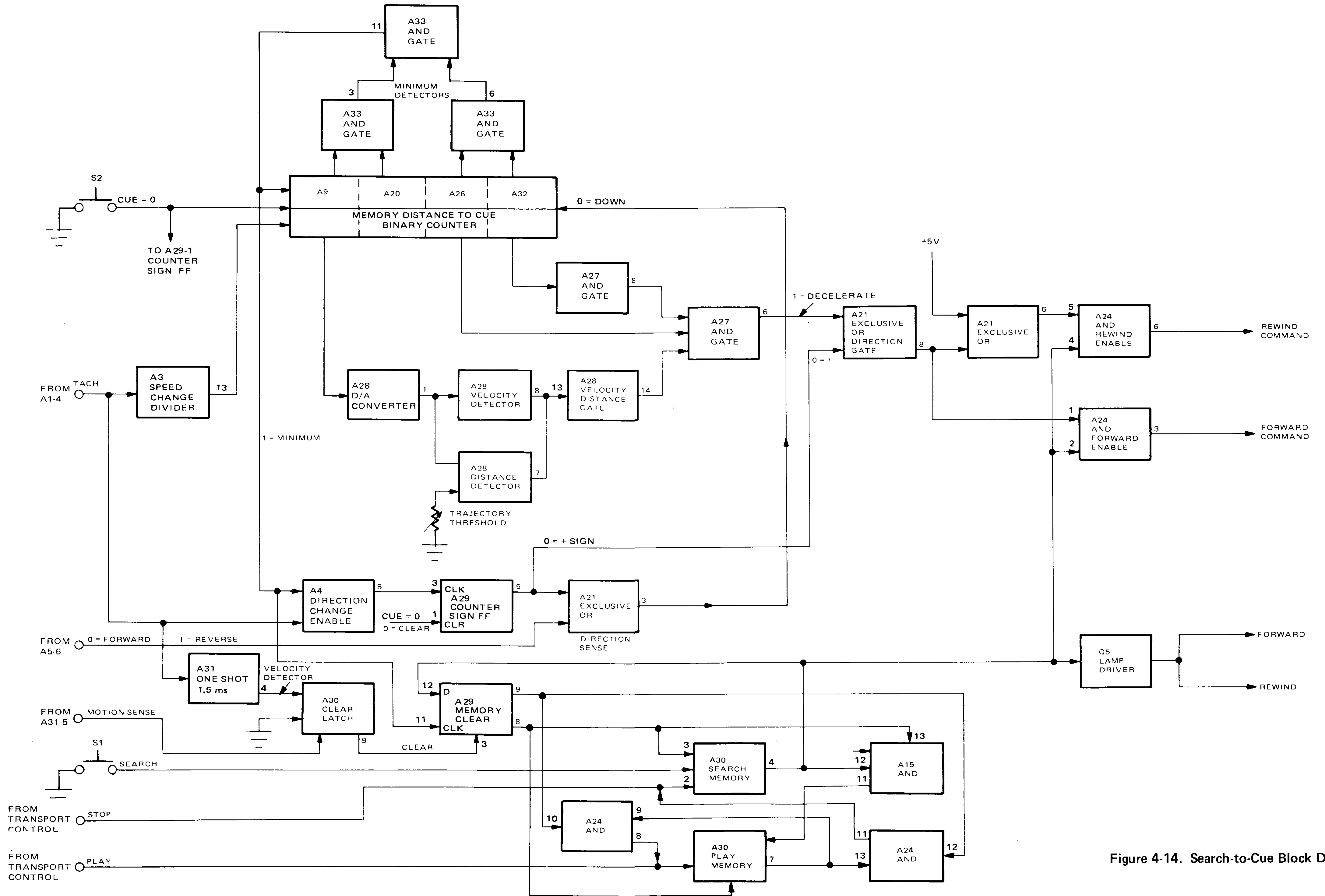

Figure 4-14. Search-to-Cue Block Diagram

now providing a rewind signal to the EXCLUSIVE OR gate A21-3. This situation continues until a decelerate command occurs.

A decelerate command can be inhibited in two ways: (1) If the distance to the CUE point is greater than 170 feet, then high signals from A32 and A26 disable gates A27-8 and A27-6 respectively; (2) If the distance to CUE is less than 170 feet but the velocity is smaller than the distance to go as compared at pin 13 of A28. As the tape moves toward zero, the counter counts down; this change is seen at the output of the D/A converter. The rate of change of the D/A converter output voltage is detected by velocity detector A28-8. If the output voltage of the velocity detector is sufficiently high, it overrides the voltage output of the distance detector, A28-7, and reverses the state of differential amplifier A28-14 to remove the logic high from the input of AND gate A27-6. This results in a logic high output from A27-6 which is sent to EXCLUSIVE OR gate A21-8 (discussed previously) and effectively inverts the output of that gate. The inverted output of A21-8 causes NAND gate A24-6 to be disabled and enables NAND gate A24-3, which sends a fast forward command to the transport control. This causes the tape to decelerate until the output voltage of the velocity detector, A28-8, no longer overrides the output voltage of the distance detector, A28-7, which restores the rewind mode in the same manner discussed previously. This slowing action continues until such time as the counter reaches a zero count, at which time AND gates A33-3, 6, and 11 are enabled, sending a transition signal, 1=MINIMUM, to NAND gate A4-8 and flip-flop A29-9/8. The logic high at the D input of flip-flop A29-9/8 is clocked through by the signal from AND gate A33-11.

If the velocity is greater than 41 in/s (sensed by A31-4) as the CUE point is crossed, then the velocity detector, A31-4, inhibits (through A30-9) the 1=MINIMUM signal at A29-11. If the velocity is less than 41, then A29-9 complements; this signal is sent to the transport control stop circuit and to search memory, A30-4. The search memory is cleared by this signal, and the search function is cancelled. When tape motion ceases, a motion stop signal is sent to flip-flop A30-9 from the

motion sensing circuitry in the tape timer. This causes A30-9 to change state, clearing A29-9/8.

If the PLAY button on the control box is pressed after the search mode is initiated (since either the fast forward or rewind control line is low during search, the PLAY button cannot set the play latch), the play command resets play memory A30-7 which enables AND gate A24-8. Then as soon as the counter reaches zero, flip-flop A29-9/8 is set for a high at A29-9. This high is ANDed with the high from A30-7 to produce the low play command which initiates the play mode. Flip-flop A29-8 also sends a logic low to the search memory which cancels the search mode, and to the play memory through NAND gate A15-11 which resets the play memory.

4-47. Reel Motor Drive Amplifiers

The motor drive amplifier (MDA) assembly contains two identical reel motor MDAs and the output transistors with their associated circuitry for the capstan servo MDA (refer to *Capstan Servo*, paragraph 4-48, for information regarding the capstan servo circuitry). One of the MDAs drives the supply reel motor, and the other drives the takeup reel motor. Since the two are identical, only one is discussed in the following paragraphs (see Figure 4-15). The incoming tension error signal comes from the transport control logic and is a function of the tension error sensor position or a fast wind signal (refer to paragraph 4-37). The incoming signal passes through potentiometer R16 and resistor R6 to the negative input of differential amplifier A1. The bias point of the differential amplifier negative input is determined by resistors R1 and R2. The amplified error signal is sent out of the differential amplifier to transistor Q3. Transistor Q3, emitter follower Q1, and transistors Q105 and Q106 and their associated circuitry form a feedback-controlled current amplifier which controls the amount of current (hence torque) permitted through to the reel motor.

The ac reel motor is connected to diode bridge, CR102, such that a positive voltage is always present at the collectors of all the transistors in the feedback amplifier. By this method, varying the signal on the bases of transistors Q105 and Q106 will vary the amount of current available to the

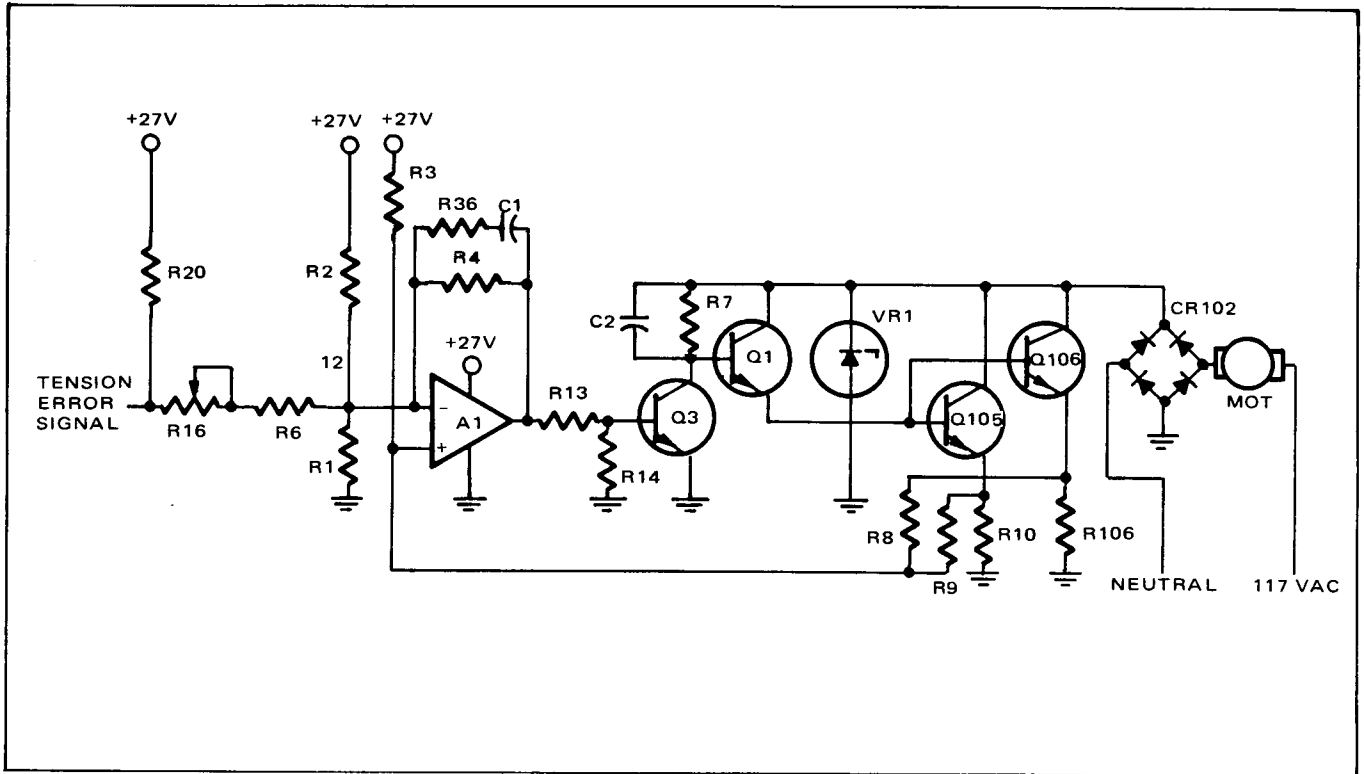

Figure 4-15. Reel Motor Drive Amplifier Simplified Schematic

reel motor. Two transistors (Q105 and Q106) are used for current handling due to the large amounts of current required. Resistors R105 and R106 are used for current sensing and for balancing of the two transistors. The current sensed by resistors R105 and R106 is summed through resistors R8 and R9 and is fed back to the positive input of the differential amplifier A1, thereby maintaining linear motor current control. Diode VR1 is a 200-volt zener diode and is used for transient suppression. Resistor R7 and capacitor C2 form a low-pass filter which limits the frequency range of the feedback amplifier.

4-48. CAPSTAN SERVO

The closed-loop capstan servo system consists of the capstan servo PWA; an amplifier on the MDA assembly; and a high-torque, tachometer-equipped dc motor. The tape is driven directly by the shaft of the motor.

4-49. Block-Diagram Description

Figure 4-16 shows a block diagram of the capstan servo system. During operation, tachometer pulses are provided at a rate proportional to capstan speed. These pulses are amplified and fed to one input of a digital phase comparator. The other input to the phase comparator is a reference signal. This signal is derived from a reference oscillator and divider circuit on the capstan servo PWA or an external reference-frequency source. A pulse shaper converts the input reference signal into a train of square pulses. This pulse train is then divided by a factor of two (for 30-in/s speed), four (for 15-in/s speed), or eight (for 7-1/2-in/s speed). The divided signal is applied to an overspeed limiter, which, in turn, drives the reference input to the phase comparator.

The phase comparator compares the tachometer signal with the selected reference signal and produces an output that is proportional to the phase difference between the two signals. The phase-comparator output can vary from a low or high

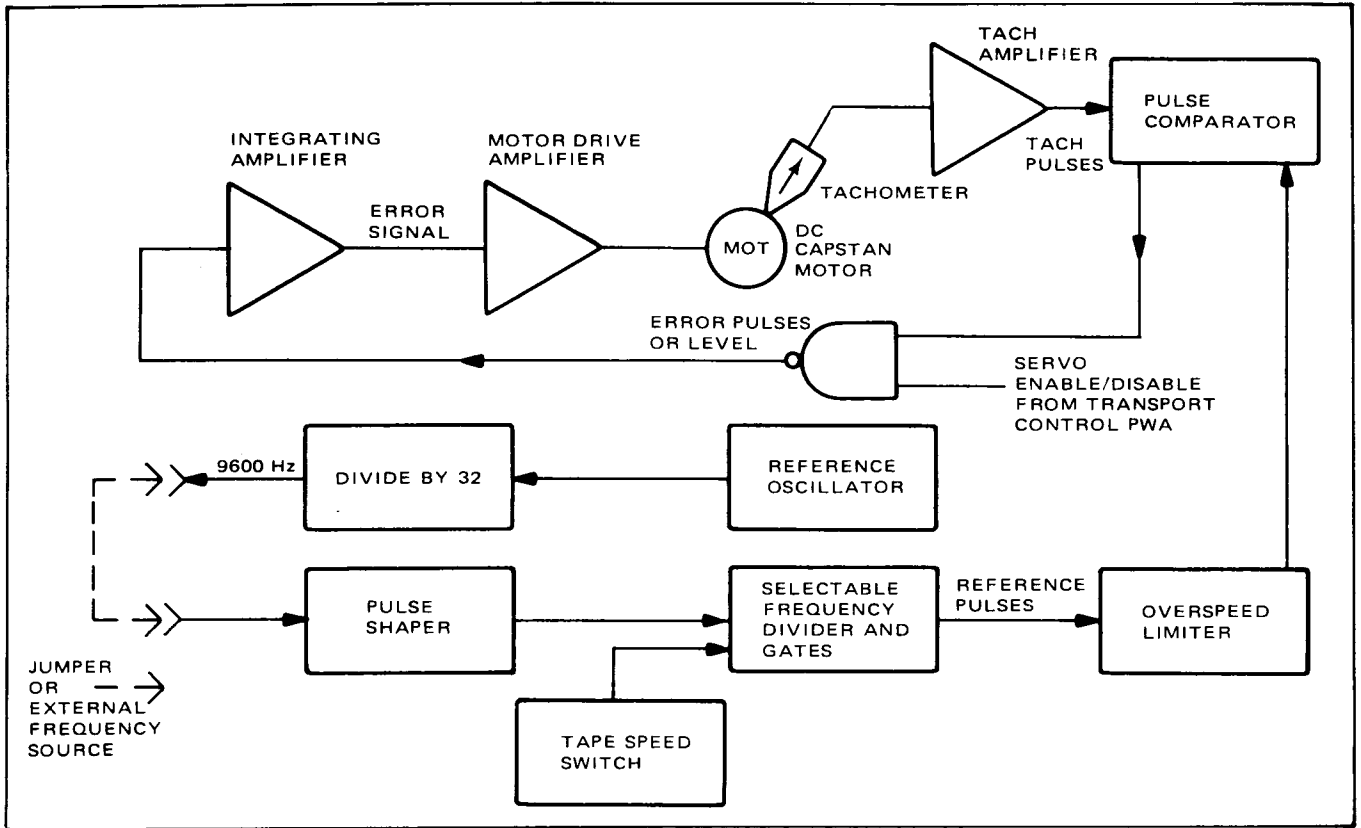

Figure 4-16. Capstan Servo Block Diagram

level for an extreme underspeed or overspeed condition, to a symmetrical square wave for an on-speed condition. During the record or reproduce mode, this speed-proportional output is integrated to form an error signal, which is amplified by the capstan MDA and used to drive the capstan motor. If the capstan motor slows, the error signal causes the MDA to provide more current to the capstan motor to increase its speed. Conversely, if the capstan motor overspeeds, the MDA supplies less current to the motor causing it to slow.

The overspeed limiter prevents severe overspeeding of the capstan motor if the frequency of the external reference oscillator (when used) is set too high. If the reference frequency increases to a preset limit, the output of the limiter becomes a high level. This level causes the phase comparator to produce a low output that stops the capstan motor.

4-50. Circuit Description

Stage A5, crystal Y1, and associated components comprise the internal reference oscillator (see schematic 4840356). Crystal Y1 is situated in the feedback path of stage A5 and is series resonant at 307.2 kHz. Consequently, only a 307.2-kHz signal is fed back with minimum attenuation, causing the stage to oscillate at 307.2 kHz. This 307.2-kHz signal is fed to stage A1.

Stage A1 is an integrated circuit that is connected to divide the oscillator signal by 16. In turn, the 19.2-kHz output of stage A1 is halved in frequency by flip-flop A3-8/9. Normally, either the 9,600-Hz output of flip-flop A3-8/9 or an external 9,600-Hz signal is applied to pin 9 of the capstan servo PWA.

Diode CR1 protects the base/emitter junction of transistor Q6 from large-amplitude negative-going spikes. Transistor Q6 and associated components

amplify the clipped and attenuated signal and drive Schmitt trigger A11-8. The Schmitt trigger rids the signal of noise and delivers a cleanly shaped pulse train to the input of flip-flop A3-6/5.

Flip-flops A3-6/5, A2-8/9, and A2-6/5 are interconnected to form a divider chain. This divider chain is connected to strapping points E1, E4, E3, and E6 such that division by 1, 2, 4, or 8 is possible. For 15-30-in/s operation, strapping points E5 to E3 and E2 to E4 are interconnected. For 7-1/2-15-in/s operation, strapping points E5 to E4 and E2 to E1 are interconnected. Thus the proper frequency division is obtained for the desired operating speed.

For 15-30-in/s operation, strapping point E2 is connected to pin 13 of NAND gate A7-11, and E5 is connected to pin 10 of NAND gate A7-8. Both NAND gates are also connected to the TAPE SPEED switch. Setting the TAPE SPEED switch to LOW enables gate A7-11 and disables gate A7-8. Conversely, setting the TAPE SPEED switch to HIGH enables gate A7-8 and disables gate A7-11. Therefore, depending on the position of the TAPE SPEED switch, either a 4,800-pps or 2,400-pps pulse train is delivered to pin 1 of retriggerable one-shot A10 (overspeed limiter).

In normal operation, one-shot A10 delivers a train of negative-going pulses at a repetition rate of 4,800 or 2,400 pps to pin 6 of flip-flops A8, A9, and A6 (phase comparator). If the repetition rate of the pulse train applied to pin 1 of retriggerable one-shot A10 exceeds approximately 12,000 pps, the output of A10 becomes a high level. This high level will cause the phase comparator to stop the capstan motor, thus preventing the motor from overspeeding.

Tach pulses from the capstan-motor tachometer coil are applied to transistor Q8. Transistors Q8 and Q7 form a high-gain, non-inverting amplifier. Resistor R37 provides a dc feedback path and together with resistor R31 sets the gain of the amplifier. Capacitors C22 and C17 provide high-frequency and low-frequency roll-offs, respectively. The amplified tach signal taken from the collector of Q7 is shaped by Schmitt trigger A11-6, inverted by inverter A7-6, and applied to pin 5 of flip-flops A8, A9, and A6 (phase comparator).

Figure 4-17 shows a typical set of waveforms for the capstan phase comparator and a table listing the signal conditions at pins A8-11, A9-11, and A6-3 for each motor-speed condition. The waveforms of this figure depict a situation similar to the time when the capstan motor is accelerating to operating speed after starting. Notice that when the tach-signal (T) frequency reaches and then exceeds the reference-signal (R) frequency, two T pulses occur between adjacent R pulses. At this point flip-flop A9-3/11 begins changing state and a square wave that contains phase information appears at pin A9-11.

When the capstan motor reaches the correct speed (synchronized operation), the R and T pulses alternate and a rectangular wave is produced at pin A9-11. Notice that while the motor is increasing speed and when it is synchronized, pin 3 of flip-flop A6-3/11 is low. Further notice that during the same time interval, each T pulse causes the signal at pin A8-11 to go low, but the following R pulse returns the signal to a high level. After the instant that the tach-signal frequency exceeds the reference-signal frequency (termed overshoot, flip-flop A8-3/11 stops changing state; and the signal at pin A8-11 stays low during synchronized operation. In actual operation, although Figure 4-17 does not show it, the overshoot may be enough to cause several pulses at pins A6-3 and A8-11.

When the motor is slowing (for example, from 30 in/s to 15 in/s), pin A9-11 remains low until the capstan is turning below the correct speed (undershoot). During the undershoot interval, two T pulses occur between adjacent R pulses. Subsequently, a rectangular wave at the correct frequency is again produced at pin A9-11. (The motor-slowness sequence is not shown in Figure 4-17.) The signal at pin A6-3 is normally high and is forced low by each R pulse when the motor is slowing. At the instant of undershoot, the signal at pin A6-3 goes low and stays low. Further, the signal at pin A8-11 remains low (as the signal at pin A6-3 does when the motor is coming up to speed). However, a few pulses may appear at pin A8-11 at the instant of undershoot because the undershoot may be enough to require the motor to increase speed slightly before arriving and remaining at the correct speed.

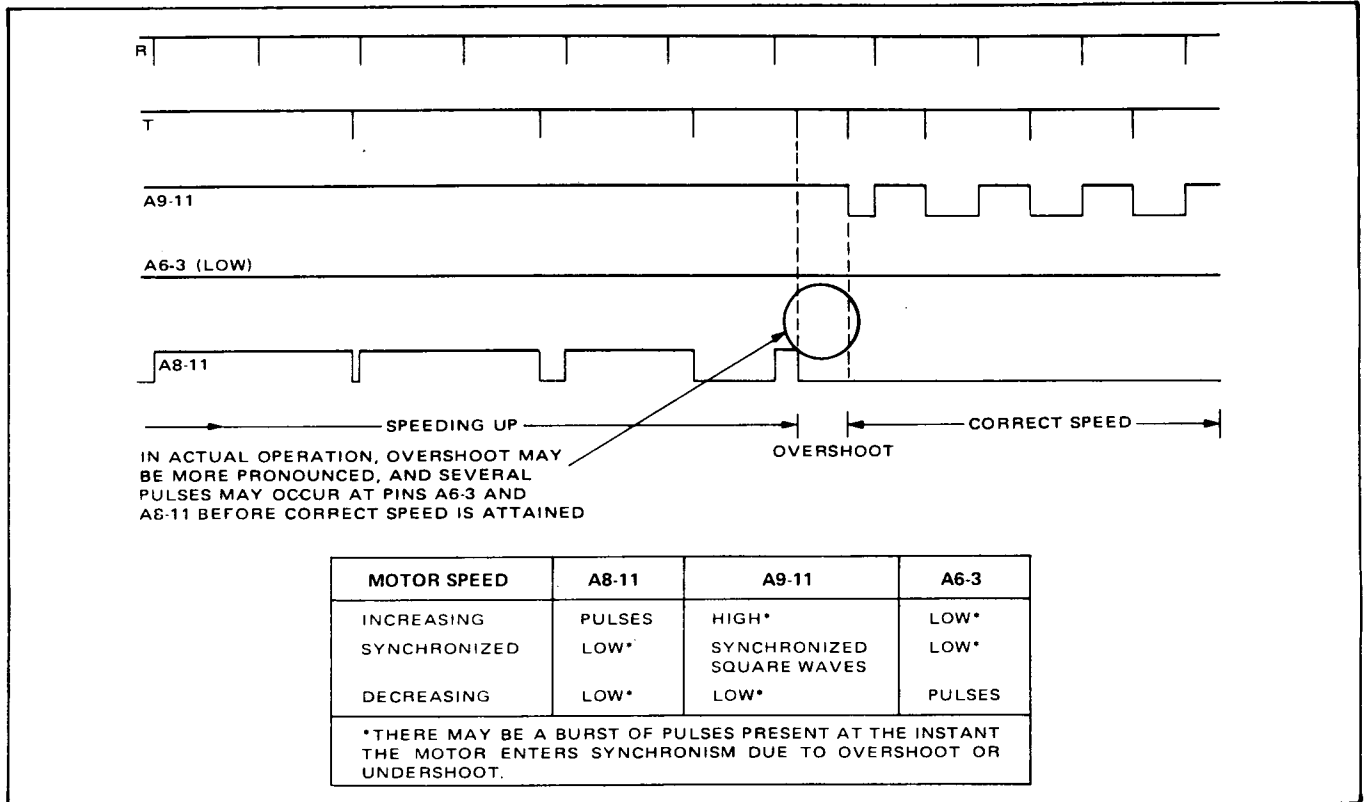

Figure 4-17. Capstan Phase Comparator, Typical Waveform

The output of the phase comparator is applied to NAND gate A7-3. During the play mode, this gate is enabled by a high level from the transport control PWA, allowing the phase-comparator output to be applied to the base of transistor Q1.

Transistor Q1 and associated components form a level-shifting stage to match the integrated circuitry with the discrete circuitry. The signal developed at the collector of Q1 is coupled to the base of transistor Q2. Transistor Q2 and associated components form a double-integrating active filter. The output signal taken from the emitter of Q2 is again integrated by another double-integrating active filter (Q3 and associated components). The signal taken from the emitter of Q3 is routed through a lead/lag network (R21, R22, R23, C14) to pin 5 of integrated circuit A4. The lead/lag network supplies the necessary phase shifts to keep the capstan servo system stable.

Integrated circuit A4 is a differential amplifier that compares the output of the lead/lag network with the feedback signal from the capstan motor drive amplifier. The difference signal developed at the output of A4 is coupled through an attenuator (R25, R26) to the base of Q4.

Transistor Q4 supplies the base-drive current for the capstan motor drive amplifier (Q103, R103, Q104, R104, and R107) located on the MDA assembly. The capstan motor forms the collector load for transistors Q5 and Q8, which are connected in parallel for good power dissipation. Potentiometer R19 on the capstan servo PWA is used to adjust the feedback signal, which, in turn, sets overall servo gain.

Transistor Q5, voltage-regulating diode VR1, and associated components on the capstan servo PWA form a 5-volt regulator. The input 15 Vdc is filtered by capacitor C5 and impressed across the

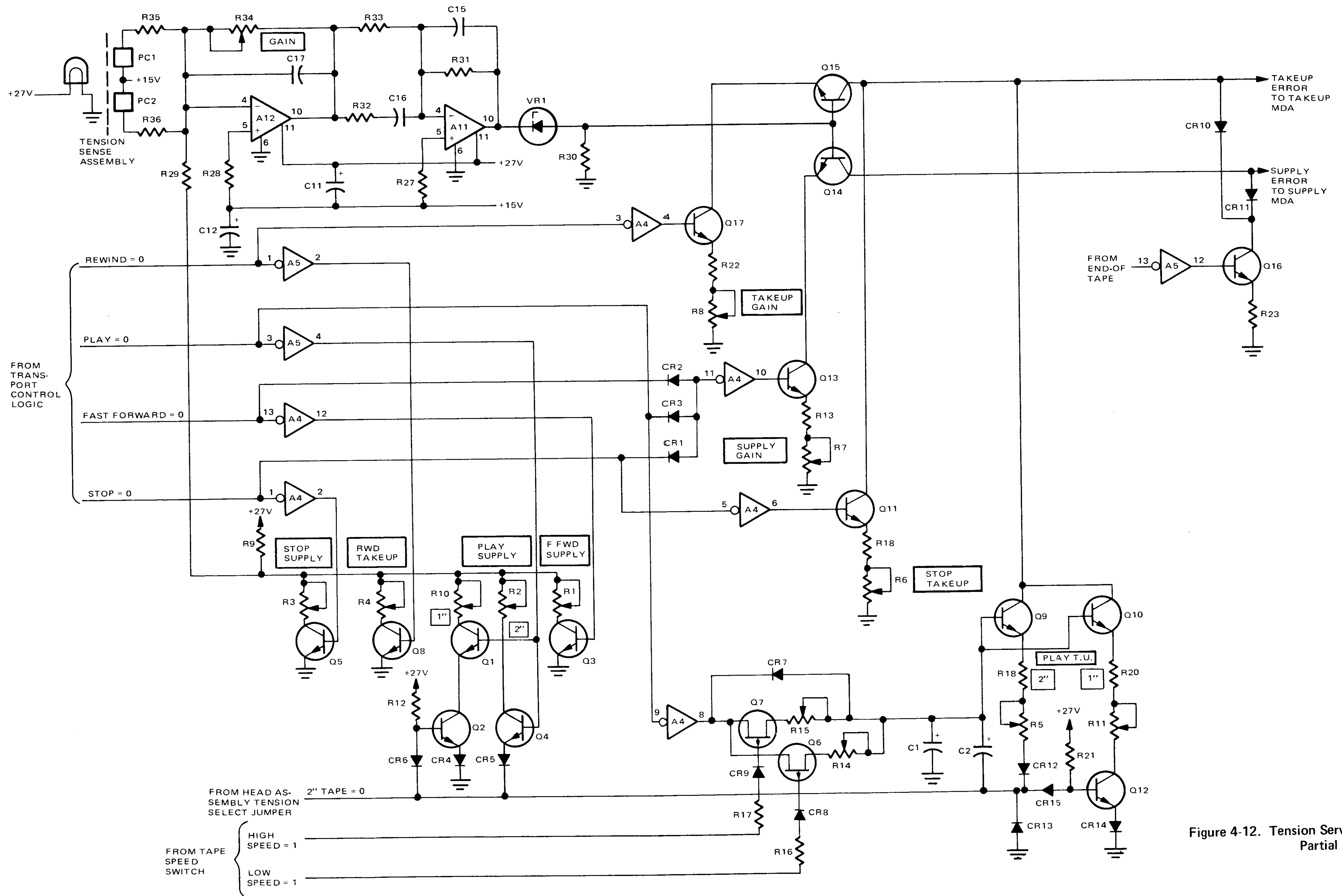

Figure 4-12. Tension Servo Circuits Partial Schematic

furnished to inverters A4-10 and A4-12. The resulting high produced by these inverters turn on transistors Q13 and Q3 respectively. Turning on Q13 enables and sets the gain of amplifier Q14, and turning on Q3 sets the gain of the tension error amplifier. Because amplifier Q15 is not enabled, no drive is applied to the error amplifier in the takeup MDA. The takeup MDA then supplies full driving power to the takeup reel motor, causing it to develop full torque. Consequently, the tape is rapidly wound onto the takeup reel. Proper tape tension is maintained by the error signal from the tension sensor assembly. This signal is amplified by the tension error amplifier and amplifier Q14 and is used to control the supply MDA, which in turn controls the holdback torque of the supply reel motor.

4-42. Stop. When the stop mode is selected and the tape has ceased motion, the stop tension line to inverters A4-6, A4-10, and A4-2 is low. The resulting highs turn on transistors Q11, Q13, and Q5 respectively. With Q11 turned on, a constant current is supplied to the takeup MDA which provides constant drive. Turning on Q13 sets the gain for Q14 in the supply error line, and turning on Q5 sets the gain of the tension error amplifier. The error signal developed by the tension error assembly is amplified by the tension error drive amplifier Q14 and the supply amplifier, providing sufficient drive to the supply reel motor to offset the torque of the takeup reel motor to hold the tape at rest under normal tension.

4-43. End-of-Tape. When the tape breaks or the supply is exhausted, the end-of-tape logic furnishes a low to inverter A5-12. Transistor Q16 is turned on by the resulting high providing equal, low drive levels to both MDAs to prevent reel motion.

4-44. Search-to-Cue and Tape Timer

The search-to-cue and tape timer electronics are contained on the same printed wiring assembly. However, other than a common source of tachometer signals, clock signals, and a speed select gate, the search-to-cue and the tape timer electronics are entirely separate and have no dependence on each other.

4-45. Tape Timer. When a tape transport motion mode is entered, tape motion causes the tape timer idler to rotate. Attached to the timer idler is a tachometer wheel on which is a set of alternate clear and opaque segments. There are two photocouplers mounted adjacent to the tachometer wheel such that they are 90° out of phase with each other. Figure 4-13 shows a simplified block diagram of the timer portion of the search-to-cue and tape timer electronics.

The output of the photocouplers is preamplified and sent through the tachometer amplifiers and filters such that the output of one of the photocouplers is clocked through true direction flip-flop, A5, by the output of the other photocoupler. Therefore, if the tape is moving in one direction, all logic highs are clocked through the direction latch. If the tape is moving in the opposite direction, all logic lows are clocked through the direction latch. A corresponding logic high or logic low output from the true direction flip-flop to EXCLUSIVE OR gate A21 is representative of tape direction. Outputs from the true direction flip-flop are also sent to the motion sense circuitry of gates A2-6/8 and transistors Q3 and Q4 which, in turn, present a logic low or high to the transport control electronics, depending on the direction of tape motion or lack of motion.

An output is taken from the tachometer amplifier (A1-4) and is sent through a divider (A3) which can be adjusted for different divide factors depending on tape speed. The tachometer signal is then sent to the synchronized tach circuitry. The output signal from the clock generator is used throughout the timer for various functions. The tachometer signal is received by the 'D' input of the synchronized tach circuit and is clocked through by the clock signal so that the output signals are one clock pulse in width. The retimed tach signals are sent to the preset input of the tachometer memory circuit (A10-5) where they are stored until required by NAND gate A15-6. The clock pulse also operates a shift register (A6/A7) which has eight outputs. The register is so arranged that as it is cycled by the incoming clock signal, all its outputs are logic high except one. The logic low appears at a different output at every clock pulse. When the logic low appears at the A7-13 output, it enables NAND gate A15-6 which then

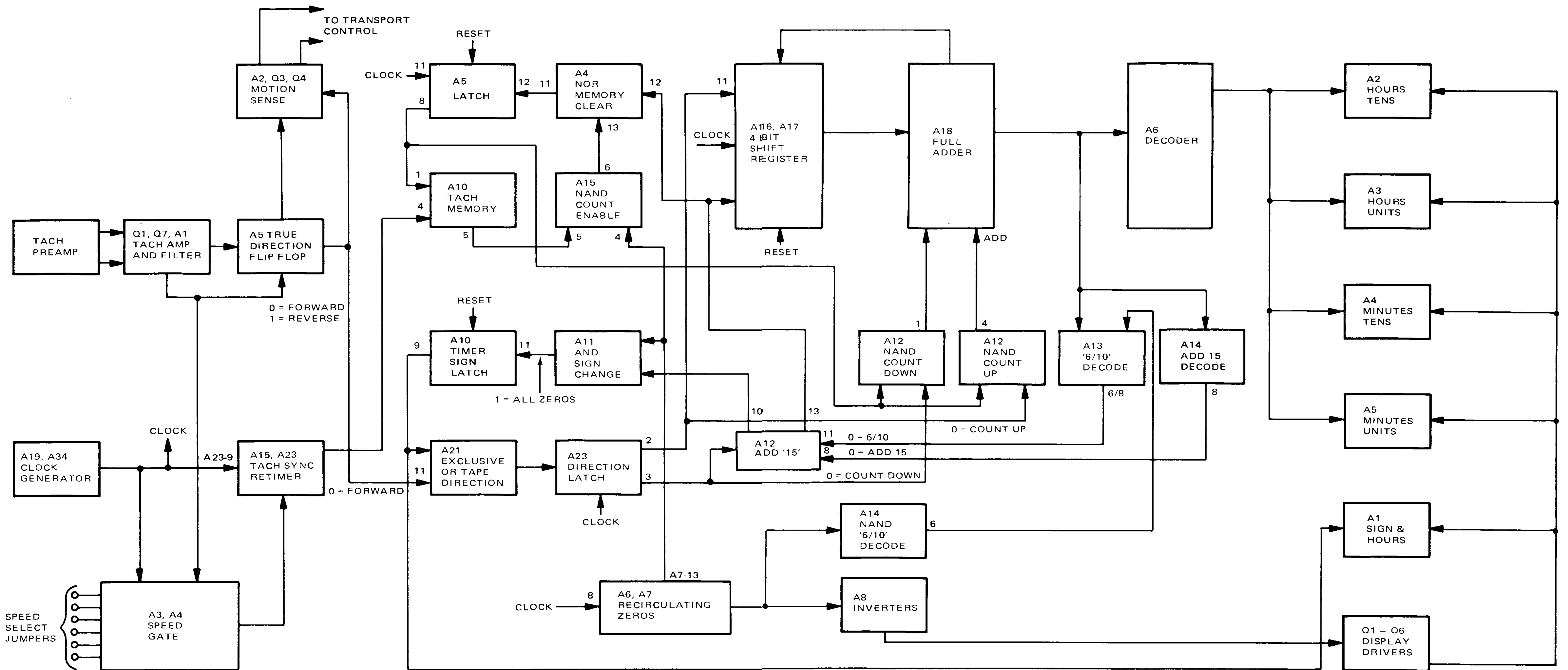

Figure 4-13. Tape Timer Block Diagram

enables NOR gate A4-11. The output of NOR gate A4-11 goes to latch A5-8 and that signal is clocked through on the next clock pulse. When the signal is checked through latch A5-8, it clears the tach memory and puts an enabling signal on the inputs of NAND gates A12-1/4. Depending on the state of EXCLUSIVE OR gate A21-11, as determined by the direction signal from direction latch, A23-2/3; either gate A12-1 (count down) or A12-4 (count up) is enabled.

In the forward direction, NAND gate A12-4 will add '1' to the full adder, increasing the count by one for each tach pulse. In the reverse direction, a '15' (binary 1111) is added to the full adder A18 by recirculating the full adder output into the shift register when enabled by the ADD 15 gate A14-8 and gate A12-10/13. Also in the count up direction, gate A13-6 or A13-8 is enabled by the output of the full adder depending on whether a binary 6 or a binary 10 is present.

If the 6 DECODER gate A13-6 is enabled by a 6 (binary 0110) appearing at its input, it enables gate A12-13 which, in turn, enables NOR gate A4-11 which presents a logic high at latch A5 input in the same manner as tach pulses. Then, when the next clock pulse occurs, that logic high stored at the input of latch A5 is clocked through to NAND gate A12-4 and a 1 is added to the number stored in the full adder (A18).

The same procedure occurs when a 10 count is detected by 10 DECODER gate A13-8. This action causes the shift registers A16 and A18 to count in modulus 6 or 10 and carry a 1 to the next significant digit.

Also when counting down, when all the units of hours, minutes, and seconds are at zero, AND gate A11-1 receives an 'all zeros' signal from gate A12-10 which complements the timer sign latch A10-9 which causes direction latch A23-2/3 to change state. The timer sign +LED is enabled or disabled by the state of latch A10-9. The timer LEDs are driven by the display drivers, Q1 through Q6, which are enabled by the pulses from the recirculating zeros shift register A6/A7.

4-46. Search-to-Cue. Refer to Figure 4-14. When a transport mode is entered, an output from the speed change divider A3 (described in paragraph 4-45) is sent to a binary counter consisting of A9, A20, A26, and A32. The counter simply counts tach pulses until cleared by a cue signal. This same cue signal also clears counter sign flip-flop A29-5, which places a logic low at one input of EXCLUSIVE OR gate A21-3. When a tape forward mode is selected after depressing the CUE pushbutton, a forward motion signal (logic low) is sent from direction sensing circuitry in the timer to the other input of EXCLUSIVE OR gate A21-3. Since a logic low now appears at both inputs of A21-3, it outputs a logic low back to the counter circuitry which enables the counter to count up when tach pulses are received.

Clearing counter sign flip-flop A29-5 also places a logic low at one input of EXCLUSIVE OR gate A21-8. The other input to A21-8 will come from AND gate A27-6 when enabled from the velocity and distance detectors A28-7/8/14. The output of EXCLUSIVE OR gate A21-8 has no effect until a search command is generated.

As the tape motion continues in the forward direction, the binary counter starts to fill. The counter output signals are sensed by a digital-to-analog converter consisting of differential amplifier A28-1 and its associated resistors. The D/A converter outputs an analog voltage that increases in value as the tape moves farther away from the counter zero (CUE) point in either the forward or reverse direction. The voltage from the D/A converter is sensed by variable gain differential amplifier A28-7, which is used as a distance detector since its output voltage is a function of the counter output.

If the tape has moved forward of the CUE point or is going in that direction when the SEARCH pushbutton is pressed, a logic low is sent to search memory A30-4 which resets and enables NAND gates A24-3 and A24-6. The low output of EXCLUSIVE OR gate A21-8 inhibits NAND gate A24-3 and, being inverted through EXCLUSIVE OR gate A21-6, enables NAND gate A24-6 which sends a rewind command to the transport control causing the transport to go into the rewind mode. When the tape rewinds, the counter counts down since the direction sense signal from gate A5-6 is

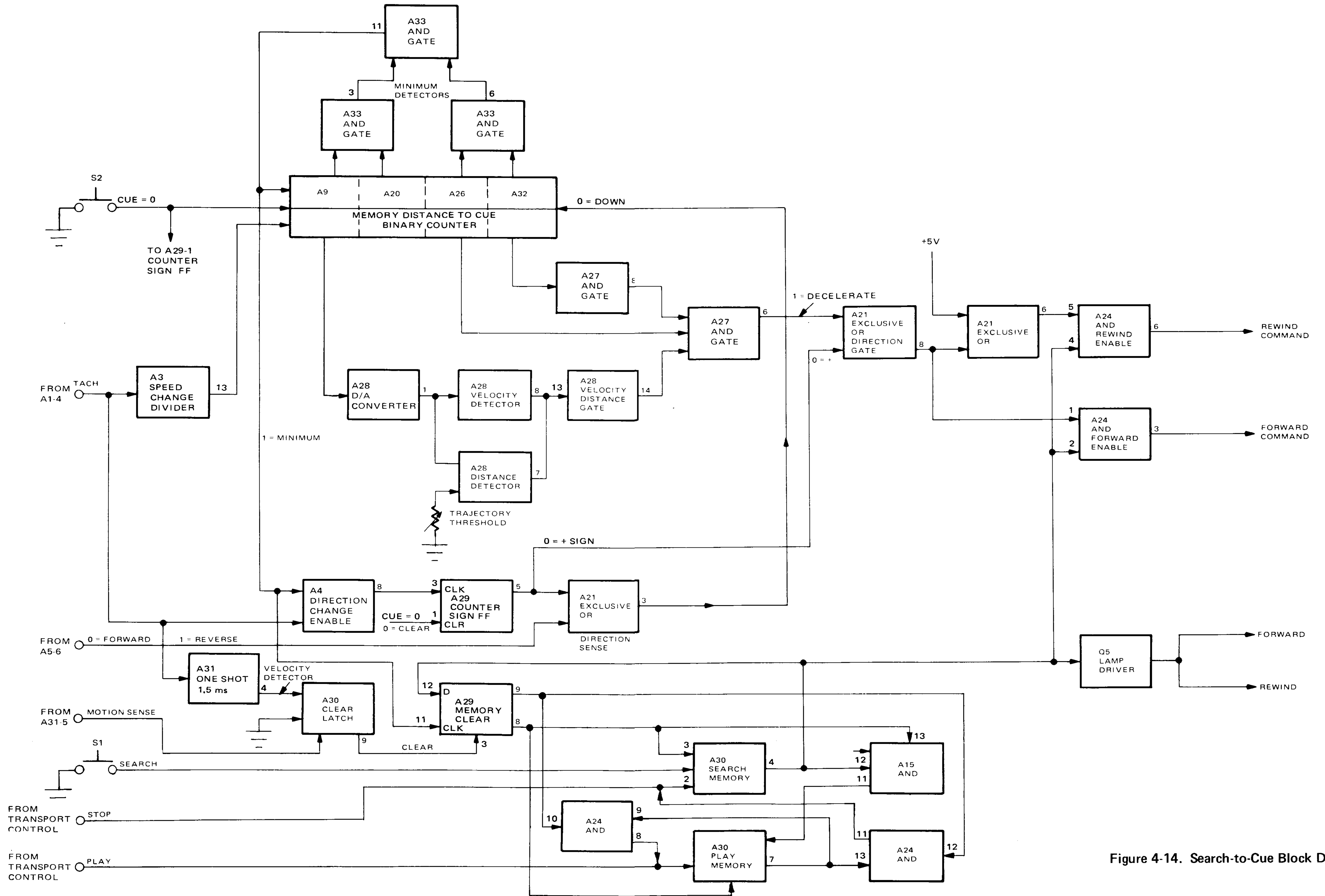

Figure 4-14. Search-to-Cue Block Diagram

now providing a rewind signal to the EXCLUSIVE OR gate A21-3. This situation continues until a decelerate command occurs.

A decelerate command can be inhibited in two ways: (1) If the distance to the CUE point is greater than 170 feet, then high signals from A32 and A26 disable gates A27-8 and A27-6 respectively; (2) If the distance to CUE is less than 170 feet but the velocity is smaller than the distance to go as compared at pin 13 of A28. As the tape moves toward zero, the counter counts down; this change is seen at the output of the D/A converter. The rate of change of the D/A converter output voltage is detected by velocity detector A28-8. If the output voltage of the velocity detector is sufficiently high, it overrides the voltage output of the distance detector, A28-7, and reverses the state of differential amplifier A28-14 to remove the logic high from the input of AND gate A27-6. This results in a logic high output from A27-6 which is sent to EXCLUSIVE OR gate A21-8 (discussed previously) and effectively inverts the output of that gate. The inverted output of A21-8 causes NAND gate A24-6 to be disabled and enables NAND gate A24-3, which sends a fast forward command to the transport control. This causes the tape to decelerate until the output voltage of the velocity detector, A28-8, no longer overrides the output voltage of the distance detector, A28-7, which restores the rewind mode in the same manner discussed previously. This slowing action continues until such time as the counter reaches a zero count, at which time AND gates A33-3, 6, and 11 are enabled, sending a transition signal, 1=MINIMUM, to NAND gate A4-8 and flip-flop A29-9/8. The logic high at the D input of flip-flop A29-9/8 is clocked through by the signal from AND gate A33-11.

If the velocity is greater than 41 in/s (sensed by A31-4) as the CUE point is crossed, then the velocity detector, A31-4, inhibits (through A30-9) the 1=MINIMUM signal at A29-11. If the velocity is less than 41, then A29-9 complements; this signal is sent to the transport control stop circuit and to search memory, A30-4. The search memory is cleared by this signal, and the search function is cancelled. When tape motion ceases, a motion stop signal is sent to flip-flop A30-9 from the

motion sensing circuitry in the tape timer. This causes A30-9 to change state, clearing A29-9/8.

If the PLAY button on the control box is pressed after the search mode is initiated (since either the fast forward or rewind control line is low during search, the PLAY button cannot set the play latch), the play command resets play memory A30-7 which enables AND gate A24-8. Then as soon as the counter reaches zero, flip-flop A29-9/8 is set for a high at A29-9. This high is ANDed with the high from A30-7 to produce the low play command which initiates the play mode. Flip-flop A29-8 also sends a logic low to the search memory which cancels the search mode, and to the play memory through NAND gate A15-11 which resets the play memory.

4-47. Reel Motor Drive Amplifiers

The motor drive amplifier (MDA) assembly contains two identical reel motor MDAs and the output transistors with their associated circuitry for the capstan servo MDA (refer to *Capstan Servo*, paragraph 4-48, for information regarding the capstan servo circuitry). One of the MDAs drives the supply reel motor, and the other drives the takeup reel motor. Since the two are identical, only one is discussed in the following paragraphs (see Figure 4-15). The incoming tension error signal comes from the transport control logic and is a function of the tension error sensor position or a fast wind signal (refer to paragraph 4-37). The incoming signal passes through potentiometer R16 and resistor R6 to the negative input of differential amplifier A1. The bias point of the differential amplifier negative input is determined by resistors R1 and R2. The amplified error signal is sent out of the differential amplifier to transistor Q3. Transistor Q3, emitter follower Q1, and transistors Q105 and Q106 and their associated circuitry form a feedback-controlled current amplifier which controls the amount of current (hence torque) permitted through to the reel motor.

The ac reel motor is connected to diode bridge, CR102, such that a positive voltage is always present at the collectors of all the transistors in the feedback amplifier. By this method, varying the signal on the bases of transistors Q105 and Q106 will vary the amount of current available to the

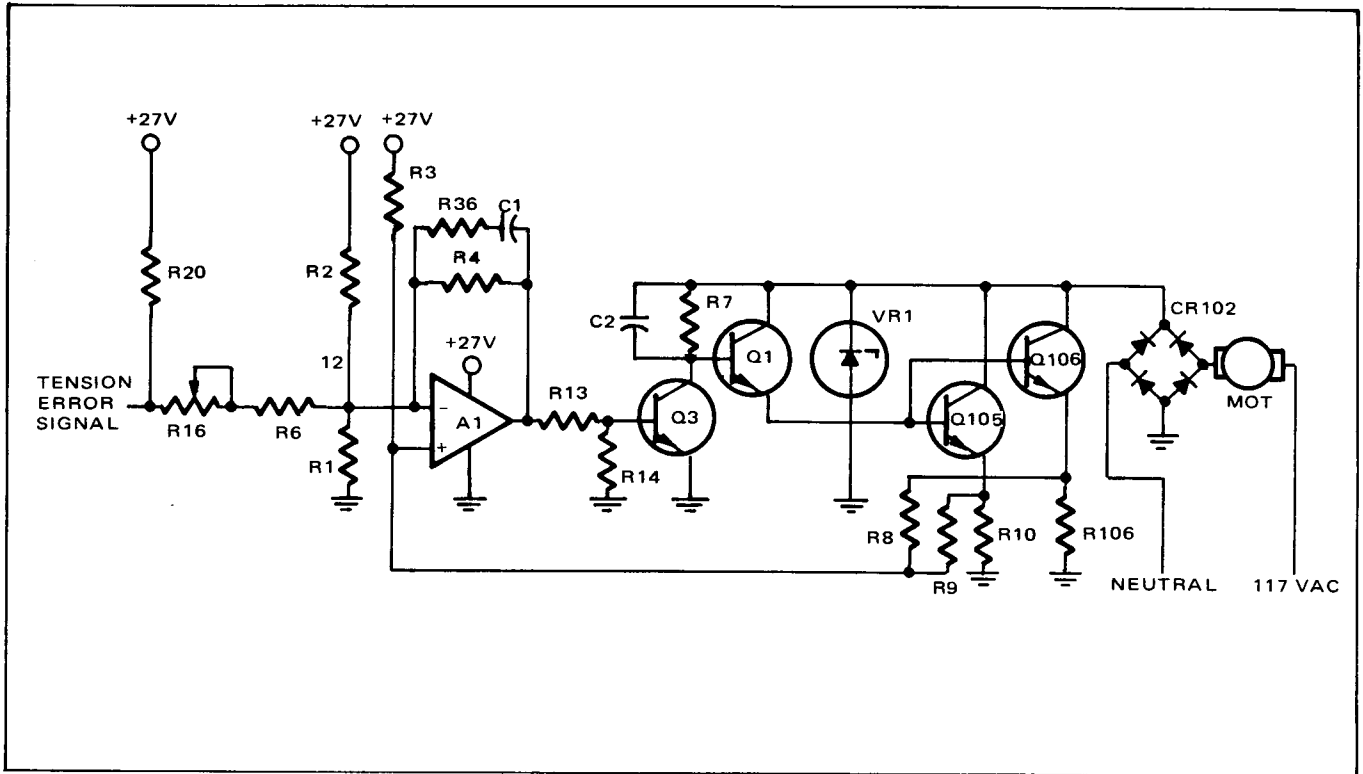

Figure 4-15. Reel Motor Drive Amplifier Simplified Schematic

reel motor. Two transistors (Q105 and Q106) are used for current handling due to the large amounts of current required. Resistors R105 and R106 are used for current sensing and for balancing of the two transistors. The current sensed by resistors R105 and R106 is summed through resistors R8 and R9 and is fed back to the positive input of the differential amplifier A1, thereby maintaining linear motor current control. Diode VR1 is a 200-volt zener diode and is used for transient suppression. Resistor R7 and capacitor C2 form a low-pass filter which limits the frequency range of the feedback amplifier.

4-48. CAPSTAN SERVO

The closed-loop capstan servo system consists of the capstan servo PWA; an amplifier on the MDA assembly; and a high-torque, tachometer-equipped dc motor. The tape is driven directly by the shaft of the motor.

4-49. Block-Diagram Description

Figure 4-16 shows a block diagram of the capstan servo system. During operation, tachometer pulses are provided at a rate proportional to capstan speed. These pulses are amplified and fed to one input of a digital phase comparator. The other input to the phase comparator is a reference signal. This signal is derived from a reference oscillator and divider circuit on the capstan servo PWA or an external reference-frequency source. A pulse shaper converts the input reference signal into a train of square pulses. This pulse train is then divided by a factor of two (for 30-in/s speed), four (for 15-in/s speed), or eight (for 7-1/2-in/s speed). The divided signal is applied to an overspeed limiter, which, in turn, drives the reference input to the phase comparator.

The phase comparator compares the tachometer signal with the selected reference signal and produces an output that is proportional to the phase difference between the two signals. The phase-comparator output can vary from a low or high

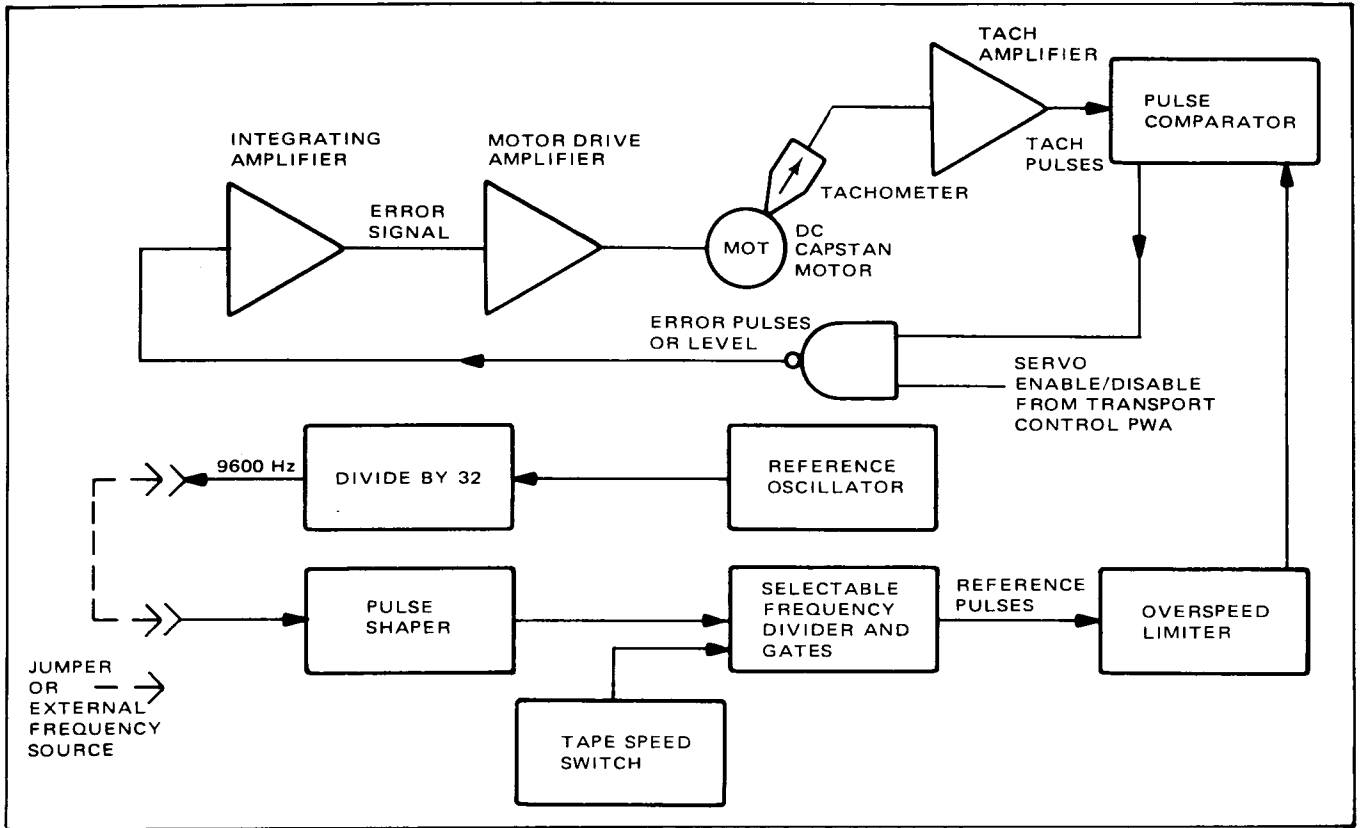

Figure 4-16. Capstan Servo Block Diagram

level for an extreme underspeed or overspeed condition, to a symmetrical square wave for an on-speed condition. During the record or reproduce mode, this speed-proportional output is integrated to form an error signal, which is amplified by the capstan MDA and used to drive the capstan motor. If the capstan motor slows, the error signal causes the MDA to provide more current to the capstan motor to increase its speed. Conversely, if the capstan motor overspeeds, the MDA supplies less current to the motor causing it to slow.

The overspeed limiter prevents severe overspeeding of the capstan motor if the frequency of the external reference oscillator (when used) is set too high. If the reference frequency increases to a preset limit, the output of the limiter becomes a high level. This level causes the phase comparator to produce a low output that stops the capstan motor.

4-50. Circuit Description

Stage A5, crystal Y1, and associated components comprise the internal reference oscillator (see schematic 4840356). Crystal Y1 is situated in the feedback path of stage A5 and is series resonant at 307.2 kHz. Consequently, only a 307.2-kHz signal is fed back with minimum attenuation, causing the stage to oscillate at 307.2 kHz. This 307.2-kHz signal is fed to stage A1.

Stage A1 is an integrated circuit that is connected to divide the oscillator signal by 16. In turn, the 19.2-kHz output of stage A1 is halved in frequency by flip-flop A3-8/9. Normally, either the 9,600-Hz output of flip-flop A3-8/9 or an external 9,600-Hz signal is applied to pin 9 of the capstan servo PWA.

Diode CR1 protects the base/emitter junction of transistor Q6 from large-amplitude negative-going spikes. Transistor Q6 and associated components

amplify the clipped and attenuated signal and drive Schmitt trigger A11-8. The Schmitt trigger rids the signal of noise and delivers a cleanly shaped pulse train to the input of flip-flop A3-6/5.

Flip-flops A3-6/5, A2-8/9, and A2-6/5 are interconnected to form a divider chain. This divider chain is connected to strapping points E1, E4, E3, and E6 such that division by 1, 2, 4, or 8 is possible. For 15-30-in/s operation, strapping points E5 to E3 and E2 to E4 are interconnected. For 7-1/2-15-in/s operation, strapping points E5 to E4 and E2 to E1 are interconnected. Thus the proper frequency division is obtained for the desired operating speed.

For 15-30-in/s operation, strapping point E2 is connected to pin 13 of NAND gate A7-11, and E5 is connected to pin 10 of NAND gate A7-8. Both NAND gates are also connected to the TAPE SPEED switch. Setting the TAPE SPEED switch to LOW enables gate A7-11 and disables gate A7-8. Conversely, setting the TAPE SPEED switch to HIGH enables gate A7-8 and disables gate A7-11. Therefore, depending on the position of the TAPE SPEED switch, either a 4,800-pps or 2,400-pps pulse train is delivered to pin 1 of retriggerable one-shot A10 (overspeed limiter).

In normal operation, one-shot A10 delivers a train of negative-going pulses at a repetition rate of 4,800 or 2,400 pps to pin 6 of flip-flops A8, A9, and A6 (phase comparator). If the repetition rate of the pulse train applied to pin 1 of retriggerable one-shot A10 exceeds approximately 12,000 pps, the output of A10 becomes a high level. This high level will cause the phase comparator to stop the capstan motor, thus preventing the motor from overspeeding.

Tach pulses from the capstan-motor tachometer coil are applied to transistor Q8. Transistors Q8 and Q7 form a high-gain, non-inverting amplifier. Resistor R37 provides a dc feedback path and together with resistor R31 sets the gain of the amplifier. Capacitors C22 and C17 provide high-frequency and low-frequency roll-offs, respectively. The amplified tach signal taken from the collector of Q7 is shaped by Schmitt trigger A11-6, inverted by inverter A7-6, and applied to pin 5 of flip-flops A8, A9, and A6 (phase comparator).

Figure 4-17 shows a typical set of waveforms for the capstan phase comparator and a table listing the signal conditions at pins A8-11, A9-11, and A6-3 for each motor-speed condition. The waveforms of this figure depict a situation similar to the time when the capstan motor is accelerating to operating speed after starting. Notice that when the tach-signal (T) frequency reaches and then exceeds the reference-signal (R) frequency, two T pulses occur between adjacent R pulses. At this point flip-flop A9-3/11 begins changing state and a square wave that contains phase information appears at pin A9-11.

When the capstan motor reaches the correct speed (synchronized operation), the R and T pulses alternate and a rectangular wave is produced at pin A9-11. Notice that while the motor is increasing speed and when it is synchronized, pin 3 of flip-flop A6-3/11 is low. Further notice that during the same time interval, each T pulse causes the signal at pin A8-11 to go low, but the following R pulse returns the signal to a high level. After the instant that the tach-signal frequency exceeds the reference-signal frequency (termed overshoot, flip-flop A8-3/11 stops changing state; and the signal at pin A8-11 stays low during synchronized operation. In actual operation, although Figure 4-17 does not show it, the overshoot may be enough to cause several pulses at pins A6-3 and A8-11.

When the motor is slowing (for example, from 30 in/s to 15 in/s), pin A9-11 remains low until the capstan is turning below the correct speed (undershoot). During the undershoot interval, two T pulses occur between adjacent R pulses. Subsequently, a rectangular wave at the correct frequency is again produced at pin A9-11. (The motor-slowness sequence is not shown in Figure 4-17.) The signal at pin A6-3 is normally high and is forced low by each R pulse when the motor is slowing. At the instant of undershoot, the signal at pin A6-3 goes low and stays low. Further, the signal at pin A8-11 remains low (as the signal at pin A6-3 does when the motor is coming up to speed). However, a few pulses may appear at pin A8-11 at the instant of undershoot because the undershoot may be enough to require the motor to increase speed slightly before arriving and remaining at the correct speed.

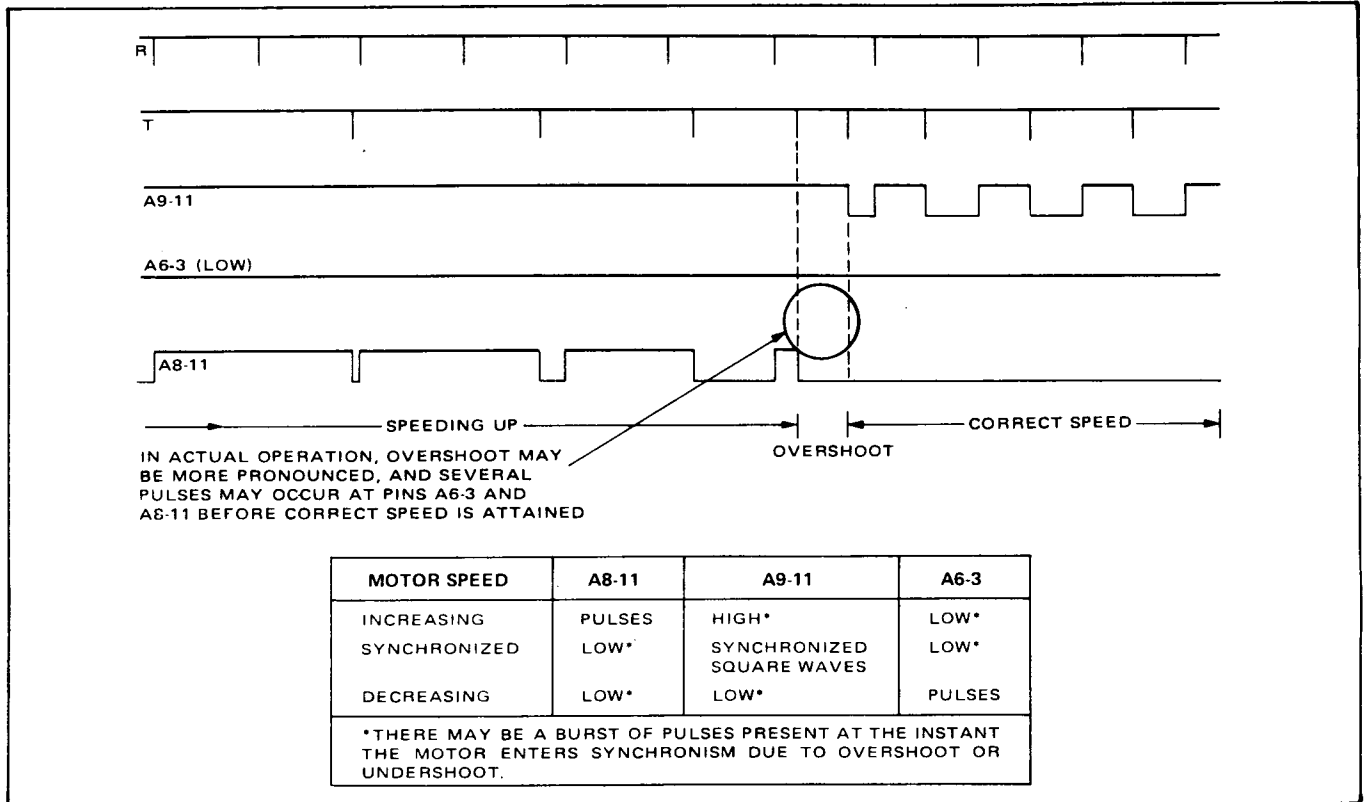

Figure 4-17. Capstan Phase Comparator, Typical Waveform

The output of the phase comparator is applied to NAND gate A7-3. During the play mode, this gate is enabled by a high level from the transport control PWA, allowing the phase-comparator output to be applied to the base of transistor Q1.

Transistor Q1 and associated components form a level-shifting stage to match the integrated circuitry with the discrete circuitry. The signal developed at the collector of Q1 is coupled to the base of transistor Q2. Transistor Q2 and associated components form a double-integrating active filter. The output signal taken from the emitter of Q2 is again integrated by another double-integrating active filter (Q3 and associated components). The signal taken from the emitter of Q3 is routed through a lead/lag network (R21, R22, R23, C14) to pin 5 of integrated circuit A4. The lead/lag network supplies the necessary phase shifts to keep the capstan servo system stable.

Integrated circuit A4 is a differential amplifier that compares the output of the lead/lag network with the feedback signal from the capstan motor drive amplifier. The difference signal developed at the output of A4 is coupled through an attenuator (R25, R26) to the base of Q4.

Transistor Q4 supplies the base-drive current for the capstan motor drive amplifier (Q103, R103, Q104, R104, and R107) located on the MDA assembly. The capstan motor forms the collector load for transistors Q5 and Q8, which are connected in parallel for good power dissipation. Potentiometer R19 on the capstan servo PWA is used to adjust the feedback signal, which, in turn, sets overall servo gain.

Transistor Q5, voltage-regulating diode VR1, and associated components on the capstan servo PWA form a 5-volt regulator. The input 15 Vdc is filtered by capacitor C5 and impressed across the

series combination of resistor R6 and voltage-regulating diode VR1. The constant voltage drop across VR1 provides a fixed forward bias for transistor Q5, which causes the emitter of Q5 to be held at 5 Vdc. Capacitor C4 provides filtering for the regulated 5-Vdc bias.

4-51. POWER SUPPLY

The power supply provides the +39-volt, +27-volt, +15-volt, and +5-volt power sources required for operation of the MM-1200 Recorder/Reproducer.

Additionally, the power supply contains the oscillator which provides the bias/erase signal to the audio electronics, and a 115-volt, 60-Hz source for use by various accessories. As shown in Figure 4-18, transformer T1 provides five isolated outputs which go to the various regulators within the power supply and to 115-volt outputs. One of the 115-Vac sources powers the power supply cooling fans. The transformer has multiple input taps so that an input range of from 105 to 127 and 210 to 254 volts, in 5-volt steps, can be accommodated. One transformer secondary is fed to diode bridge A3, the output of which goes to regulator A4. The output of A4 provides the regulated

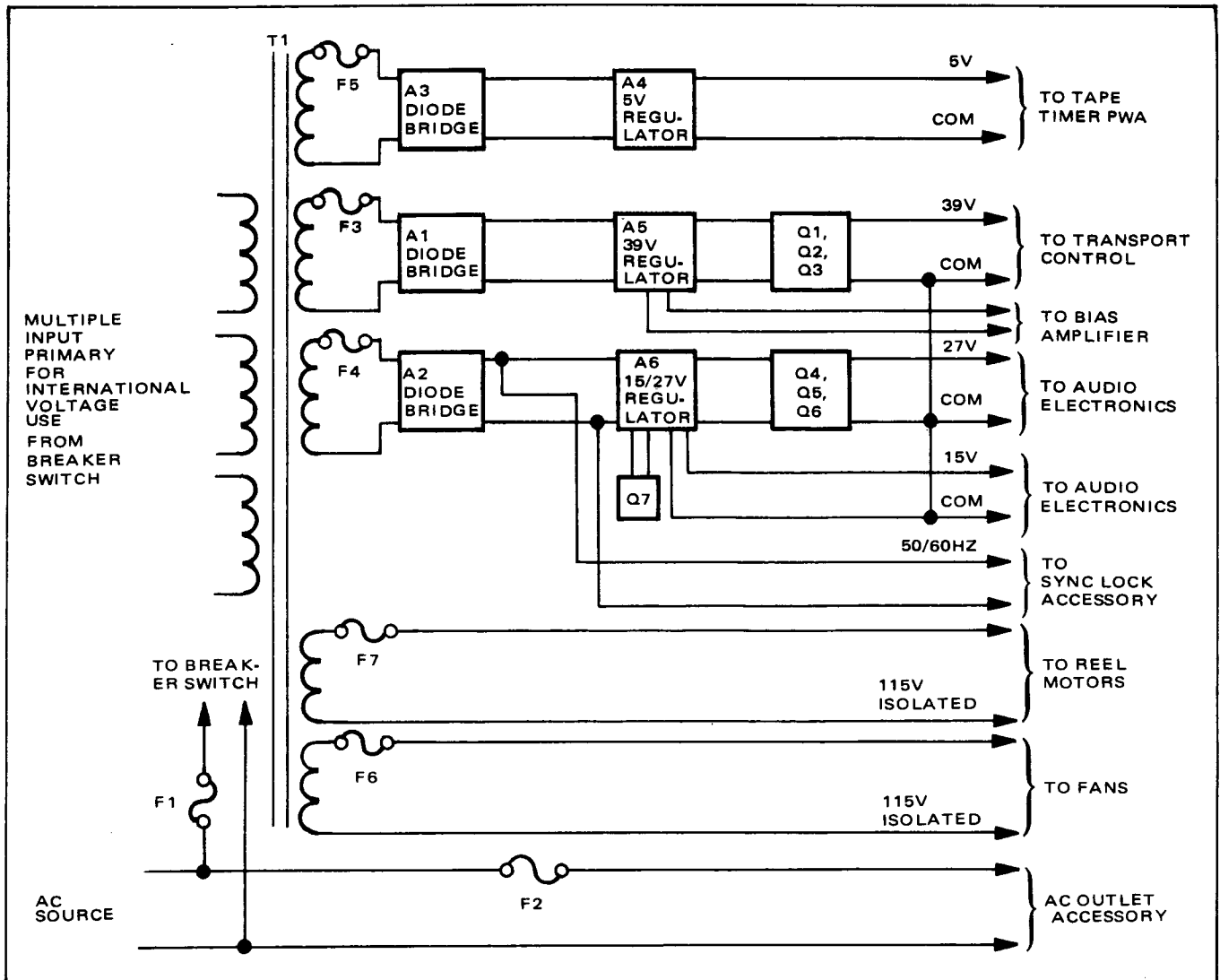

Figure 4-18. Power Supply Block Diagram

5 volts used by the search-to-cue and tape timer electronics. Another transformer secondary is routed to diode bridge A1, the output of which goes to regulator A5. Regulator A5 contains the necessary circuitry to regulate the +39-Vdc power source to the relays, solenoids, etc., and also contains an oscillator which generates the drive signal required by the bias/erase amplifiers in the electronics assembly.

Diode bridge A1 also provides source current to transistors Q1 and Q2, which are connected in parallel to form the series pass element of the 39-volt power supply. Referring to schematic 4840404, resistors R7 and R8 are used to balance transistors Q1 and Q2 and to sense the amount of current drawn by each. The signal sensed by R7 and R8 is summed through resistors R3 and R4 respectively, and is returned to regulator A1 as a feedback signal. Transistor Q3 drives transistors Q1 and Q2 and in turn is controlled by the regulator circuitry. Capacitor C4 provides output filtering for the regulated +39 Vdc.

A third transformer secondary is fed to diode bridge A2, the output of which goes to the input of regulator A6. Regulator A6 provides regulation for the +27- and +15-volt power sources that are used by the audio electronics and the illumination devices. Diode bridge A2 also provides source current to transistors Q4 and Q5 which are connected in parallel to form the series-pass element of the 27-volt power supply. Referring to schematic 4840404, resistors R9 and R10 are used to balance transistors Q4 and Q5 and to sense the amount of current drawn by each. The signal sensed by resistors R9 and R10 is summed through resistors R5 and R6 respectively and is returned to regulator A6 for feedback. Transistor Q6 drives transistors Q4 and Q5 and, in turn, is controlled by the regulator circuitry. Capacitor C5 provides output filtering for the regulated +27 Vdc. Transistor Q7 is the series pass element for the 15-volt power supply and is controlled by the regulation circuitry in regulator A6. Capacitor C6 provides output filtering for the regulated 15 Vdc.

The rectified output of diode bridge A2 is also sent out of the power supply to be used as a reference by the sync lock accessory. The 115-Vac isolated sources are used to power the ac reel motor and fans.

4-52. 39-Vdc Regulator

Referring to schematics 4840337 (39-volt regulator) and 4840404 (power supply), filtered unregulated dc voltage is provided to pins 1 and 2 of the 39-volt regulator; and to transistor Q8 diodes CR3 and CR4; and to capacitor C1, which forms a constant current source. Diodes CR3 and CR4 and capacitor C1 provide a constant forward bias for transistor Q8. Hence, the collector current of Q8 is constant. The collector current of Q8 is shared by the emitter circuit of transistor Q9 and the base circuit of power supply transistor Q3. Consequently the more Q9 conducts, the less power supply transistor Q3 conducts and, in turn, the less power supply transistors Q1 and Q2 conduct.

Transistor Q9 is driven by a voltage comparator circuit composed of transistor Q4; resistors R25, R7, R3, and R5; potentiometer R1; capacitor C2; and voltage regulating diodes VR1 and VR3. A sample of the nominal 39-volt output is sensed at the slider of potentiometer R1 and applied to the base of transistor Q4. The emitter of Q4 is held at a constant reference voltage by the network comprised of VR1, VR3, and R7. As a result, the collector current of Q4 is directly proportional to its base/emitter voltage. Therefore, if the output voltage tends to rise, Q4 conducts more which causes Q9 to conduct more. With Q9 conducting more heavily, less base current is available to power supply transistor Q3, which, in turn, supplies less current to power supply transistors Q1 and Q2. More voltage is then dropped across power supply transistors Q1 and Q2, and the output voltage tends to drop, power supply transistors are driven harder, again causing the output voltage to be restored to 39 Vdc.

Capacitor C1 in the constant current source causes the power supply to be turned on slowly so that the initial current surge does not damage power supply circuitry. Capacitor C2 prevents the power supply from oscillating. Diode CR1 prevents the junction of resistor R7 and voltage regulator VR2 from going negative with respect to ground, thus protecting the base/emitter circuit of transistor Q4. Resistor R4 and adjustable resistor R6 and SCR Q3 form an overcurrent protection circuit for the power supply. Resistor R4 and adjustable resistor R6 sense the voltage drop across the power supply

series-pass balancing resistors (R7 and R8 in the power supply) as summed by resistors R3 and R4 (also in the power supply). Consequently, if the load increases, the voltage drop across the balancing resistors increases, and the increased voltage drop causes the voltage to rise at the junction of resistors R4 and R6. When this voltage rise reaches the trigger point of SCR Q3, SCR Q3 turns on and shorts the base/emitter junction of power supply transistors Q1, Q2 and Q3, which turns them off, removing the power from the load.

To restore the 39-Vdc power supply to normal operation, the recorder/reproducer must be turned off and then turned on again. Turning off the power allows SCR Q3 to turn off and, when the power is restored, SCR Q3 stays off until the load current is again exceeded.

Diode VR2; resistors R11, R12; capacitor C9; and SCR Q5 on the regulator PWA and resistor R8 and fuse F3 form an overvoltage protection circuit. If the output voltage becomes excessive, voltage regulator VR2 begins conducting. The resulting voltage drop across resistor R11 turns on SCR Q5, which essentially shorts the power supply to common, causing the fuse to blow. All voltage is thereby removed from the regulator circuit and the load. Capacitor C9 delays the turn on of SCR Q5 and thus prevents the overvoltage circuit from being activated by voltage transients.

4-53. Bias Oscillator

The bias oscillator is contained on and receives its power from the 39-volt regulator (refer to schematic diagram 4840337). Transistors Q6 and Q7 and associated components comprise the circuitry of the oscillator, which is a variation of a standard astable multivibrator. Capacitors C5 and C6 and resistors R21 and R22 are the basic timing elements of the multivibrator. The primary of transformer T1 and capacitor C7 form a tuned circuit that is shock excited by the push pull drive from the collectors of transistors Q6 and Q7. The tuning slug of transformer T1 adjusts the frequency of the output signal to 150 kHz.

4-54. 27-Vdc Regulator

The 27-Vdc regulator is identical in operation to the 39-volt regulator, except that the output transistors used in the power supply are Q4, Q5, and Q6.

4-55. 15-Vdc Regulator

Transistor Q7 of the 15/27-Vdc regulator is the series-pass transistor for the 15-Vdc power supply (see schematic 4840404). This pass transistor is driven by the 15-Vdc regulatory circuitry in the 15/27-Vdc regulator (see schematic 4840339). In normal operation, the current flowing through resistor R13 is shared by the base circuit of pass transistor Q7 and the collector circuit of transistor Q2. Therefore, varying the collector current of transistor Q2 varies the base current of pass transistor Q7 and, thus, the emitter current of pass transistor Q7 also. Variations in output voltage are sensed at the slider of potentiometer R2 and applied to the base of voltage comparator Q2. The emitter of transistor Q2 is held at a constant voltage by voltage regulator diode VR4. Consequently, if the output voltage tends to rise, transistor Q2 conducts more, which shunts current from the base circuit of pass transistor Q7. As a result, pass transistor Q7 conducts less, causing the output voltage to be restored to 15 Vdc. Conversely, if the output voltage tends to drop, transistor Q2 shunts less, pass transistor Q7 conducts more, and the output voltage is again restored to 15 Vdc.

Transistor Q1 and resistor R17 form an over-current protection circuit. When the current flowing through R17 causes a sufficient voltage drop, transistor Q1 turns on and shorts the base/emitter circuit of pass transistor Q7. Therefore pass transistor Q7 limits the current for the duration of the overload.

Voltage regulator diode VR5 is connected to the overvoltage circuitry of the 27-Vdc regulator. If the output voltage becomes excessive, VR5 conducts and causes the overvoltage circuit of the 27-Vdc regulator to blow fuse F4. Capacitor C3 prevents circuit oscillation and diode CR2 protects transistor Q2 from voltage transients.

4-56. 5-Vdc Regulator

The 5-volt regulator consists of a 5-volt regulator integrated circuit (A4), resistor R12, and potentiometer R11 (see schematic 4840404). The regulator (A4) outputs a constant 5 volts with respect to its common connection. Resistor R12 and

potentiometer R11 are arranged in a voltage divider configuration which can raise the regulator's common connection above ground so that the output voltage with respect to ground can vary above 5 volts. This is used to compensate for line drop between the regulator output and the search-to-cue/tape timer PWA.

SECTION 5 MAINTENANCE

5-1. GENERAL

This section provides information necessary to clean, lubricate, and demagnetize the mechanical portions of the MM-1200 Recorder/Reproducer. Also provided are procedures for electrical and mechanical adjustments, and audio setup and maintenance adjustments. Procedures are provided which outline methods of determining whether a particular mechanical, electrical, or audio function

is within adjustment limits so that unnecessary adjustments may be avoided.

5-2. TEST EQUIPMENT

Table 5-1 lists the test equipment and materials recommended to perform the maintenance procedures presented in this section.

Table 5-1. Test Equipment and Maintenance Materials

| DESCRIPTION | IDENTIFICATION | USE |
|---------------------------|----------------------------------------------|------------------------------------------------------------------|
| Flutter Bridge | Mincom Model 8155-01 or equivalent | Flutter measurement. |
| Wave Analyzer | HP Model 302A | Overall noise and distortion measurements. |
| Oscilloscope | Tektronix Model 547 or equivalent | Observation and measurement of waveforms. |
| Preamplifier | Tektronix Model 1A1 or equivalent | Interface with oscilloscope. |
| VTVM | HP Model 400D or equivalent | Audio signal measurements. |
| Multimeter | Weston Model 660 or equivalent | Voltage adjustments and overcurrent adjustments. |
| Signal Generator | HP Model 204C or equivalent | Record alignment. |
| Head Cleaner | Ampex Part No. 4010823 or equivalent | Cleaning tape heads. |
| Head Demagnetizer | Ampex Part No. 4010820 | Demagnetizing components in tape path. |
| Spring Gauge, 0-30 ounces | Hunter Spring Co. Model LO-20M or equivalent | Tape tension, takeup reel, and supply reel brake adjustments. |
| Spring Gauge, 0-10 pounds | Chatillon Co. Model R | Takeup, supply reel brakes, and capstan pinch roller adjustment. |
| Nylon Cord | | Takeup, supply reel and capstan pinch roller adjustment. |
| Tape Tension Meter | Tentel Model T2 | Measure tape tension. |

Table 5-1. Test Equipment and Maintenance Materials (Continued)

| DESCRIPTION | IDENTIFICATION | USE |
|-----------------|-------------------------------------------------------------------------------------------------------------------------------------------------------------------------------------------------------------|--------------------------------------------------------------------------------------------------------------------------------------------------------------------------------------------------------------------------------------------------------------------|
| Extender Boards | Ampex Part No. 4020151-04 Ampex Part No. 4020152-02 Ampex Part No. 4020153-04 Ampex Part No. 4020154-02 Ampex Part No. 4050695-04 Ampex Part No. 4050803-01 Ampex Part No. 4050801-01 | Extend reproduce amplifier. Extend record amplifier. Extend bias/erase amplifier. Extend power supply regulators. Extend capstan servo, tape timer and search-to-cue, and transport control PWAs. Extend audio switcher module. Extend MDA PWAs. |

5-3. CLEANING

All components in the tape path should be cleaned every eight hours of transport operation, or more often if indicated by visual inspection, to remove accumulations of oxide deposited by the recording tape. Excessive oxide deposits can cause degradation of equipment performance. Proceed as follows to perform periodic cleaning procedures:

CAUTION

USE RECOMMENDED SOLVENTS WHEN CLEANING TAPE PATH COMPONENTS, AND DO NOT USE METAL TOOLS FOR CLEANING. DO NOT ALLOW TAPE HEAD CLEANER TO COME IN CONTACT WITH THE RUBBER IDLER ROLLER OR PLASTIC FINISHES. FAILURE TO OBSERVE THIS CAUTION MAY RESULT IN DAMAGE TO TAPE PATH COMPONENTS.

1. Clean tape heads with a cotton-tipped wooden applicator moistened in Ampex head cleaner. Do not allow head cleaning fluid to come in contact with capstan idler roller; the cleaning fluid will damage the rubber tire and cause tape slippage.
2. Clean tape guides, the capstan, and the capstan idler with isopropyl alcohol. Take care to remove fingerprints from the rubber idler roller and capstan, and immediately remove any oil deposits from the rubber idler roller.

CAUTION

DO NOT USE COMPRESSED AIR FOR CLEANING TRANSPORT MECHANISMS. THE AIR PRESSURE CAN FORCE DIRT PARTICLES INTO BEARINGS AND CAUSE DAMAGE TO TRANSPORT COMPONENTS.

5-4. DEMAGNETIZATION

Tape heads and other components in the path can acquire permanent magnetization which increases signal noise and distortion, and partially erases high frequencies on recorded tapes. Demagnetize tape path components after each eight hours of operation, using Ampex head demagnetizer as follows:

1. Turn equipment power off, and remove any recorded tape near the transport (tape could be partially erased by the demagnetizer).
2. Cover the demagnetizer tips with pressure-sensitive tape (to prevent scratching the heads).
3. With the demagnetizer at least three feet from the recorder, connect it to a 110-120-Vac power source.
4. Slowly move the demagnetizer toward the head stack.

5. Simultaneously and lightly touch the two demagnetizer tips to both faces of the head stack.
6. Hold the tips perfectly parallel to the stack face at all times. With a slow, even motion, move the tips up and down the stack several times. Slowly withdraw the demagnetizer (slow withdrawal is required for effective demagnetization).
7. Repeat steps 4 through 6 at each head stack and tape guide (including the one on the tape tension arm).
8. Move the demagnetizer at least three feet from the recorder; then de-energize it.

5-5. LUBRICATION

Except for the cleaning and lubrication of the scrape-flutter idler in the head assembly, described below, the MM-1200 requires no periodic lubrication. All other moving parts are permanently lubricated at the factory prior to shipment.

5-6. Scrape-Flutter Idler Lubrication

Ultrasonically clean and then lubricate the scrape-flutter idler once a year or after each 2,000 hours of operation as follows:

1. Remove the head assembly as described in paragraph 5-69.
2. Remove the scrape-flutter idler, retaining screw and lockwasher, and lift the idler off the locating pin.
3. Ultrasonically clean the complete scrape-flutter idler.
4. Lubricate each jewel bearing with one drop of jewel oil (Ampex Part No. 087-239) using a no. 21 hypodermic needle to apply the oil.
5. Mount the scrape-flutter idler on its locating pin on the head assembly and readjust, using the procedures given in this section in the

Mechanical Adjustments, Head Assembly, paragraph 5-33.

5-7. MAINTENANCE ADJUSTMENTS

The following procedures are provided to enable the user to determine if the associated circuit or hardware is within the limits of normal operation and, if not, to perform adjustments that will result in normal operation. Since the adjustment of the power supply can affect the overall operation of the recorder/reproducer, that check and adjustment procedure is presented first. Subsequent system adjustments are selected so that their adjustment will have the least amount of effect on any preceding adjustment.

5-8. Power Supply

The adjustments to the power supply are contained on the 39-volt, the 15/27-volt and the 5-volt regulator assemblies. Check and adjust these regulator assemblies as described in the following paragraphs.

5-9. 39-Volt Regulator Adjustment. Check and adjust the 39-volt regulator as follows:

1. Apply power to recorder/reproducer.
2. Connect a multimeter to 39V-TP1 (positive) and TP G (common). See Figure 5-1.
3. Observe that the voltage at 39V-TP1 is 39 ± 0.5 Vdc.
4. If the voltage at 39V-TP1 is not within the limits stated in step 3, adjust 39V-R1 as necessary to obtain the correct indication.

5-10. 15/27-Volt Regulator Adjustment – 27-Volt Section. Check and adjust the 27-volt section of the 15/27-volt regulator as follows.

1. Connect a multimeter to the 15/27V-TP1 (positive) and TP G (common).
2. Observe that the voltage is 27 ± 0.5 Vdc.

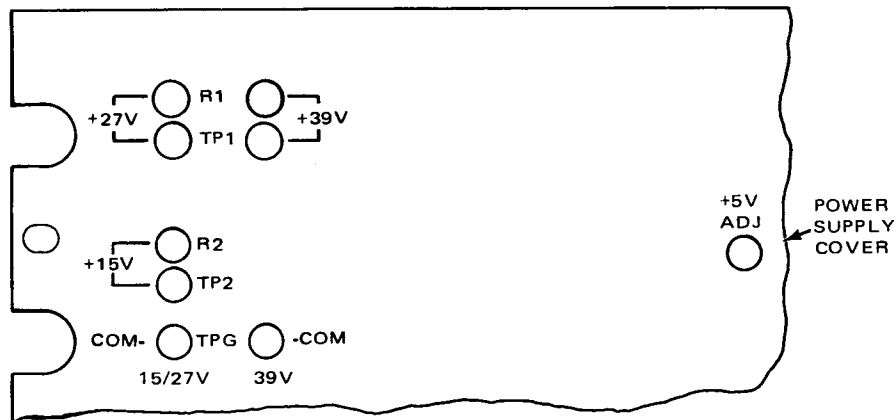

Figure 5-1. Power Supply Test Points and Adjustments

3. If the voltage at 15/27V-TP1 is not within the limits stated in step 2, adjust 15/27V-R1 as necessary to obtain the correct indication.

5-11. 15/27-Volt Regulator Adjustment – 15-Volt Section. Check and adjust the 15-volt section of the 15/27-volt regulator as follows:

1. Connect a multimeter to 15/27V-TP2 (positive) and TP G (common).
2. Observe that the voltage is 15 ± 0.5 Vdc.
3. If the voltage at 15/27V-TP2 is not within the limits stated in step 2, adjust 15/27V-R2 as necessary to obtain the correct indication.

5-12. Overcurrent Protection Adjustment. Potentiometer R6 on the 39-volt regulator and the 15/27-volt regulator is used to set the point at which the overcurrent protection circuit is triggered into operation. When the overcurrent trigger point for either regulator requires readjustment due to aging or replacement of parts, perform the following:

1. Turn recorder/reproducer power off.
2. Remove the power supply cover plate.

3. Remove the applicable regulator from its position and reinstall it using the appropriate extender board, part no. 4020154-02.
4. Thread a reel of blank tape onto the transport.
5. Set all READY/SAFE switches to the READY position.
6. Connect an ohmmeter across the outside terminals of potentiometer R6.
7. Adjust R6 for an indication of 46 ohms.
8. Connect a multimeter to TP1 (+) and TP G (common) of the regulator PWA.
9. Apply power to the recorder/reproducer. The multimeter should indicate the nominal voltage for the regulator, ± 0.5 volt. If the multimeter does not indicate the correct voltage, readjust as necessary according to the *39-Volt Regulator Adjustment*, paragraph 5-9, and *15/27-Volt Regulator Adjustment*, paragraph 5-11.
10. Put the recorder/reproducer into the record mode. If the voltage monitored at the regulator PWA does not drop to zero (indicating no

overcurrent condition), the overcurrent protection adjustment is complete. If the monitored voltage does drop to zero, proceed to steps 11 and 12.

11. Remove power from the recorder/reproducer and readjust R6 on the affected regulator PWA 1/8 turn clockwise.
12. Restore power to the recorder/reproducer and repeat steps 9 and 10.

5-13. 5-Volt Regulator Adjustment. Check and adjust the 5-volt regulator as follows:

1. Turn the recorder/reproducer power off.
2. Remove the search-to-cue/tape time PWA from its connector and reinstall it using the appropriate extender board, part no. 4050695-04.
3. Connect a multimeter to the search-to-cue/tape timer connector pins 1 (+) and 14 (-).
4. Apply power to the recorder/reproducer.
5. Adjust the +5V ADJ potentiometer at the rear of the power supply (Figure 5-1) for an indication of 5 ± 0.1 volts on the multimeter.
6. Remove power from the recorder/reproducer and reinstall the search-to-cue/tape timer PWA into its connector.

5-14. Motor Drive Amplifier

The motor drive amplifier (MDA) assembly consists of two separate motor drive amplifiers, one for each reel motor; and three sets of power handling transistors and diode bridges, two sets for the reel motors, and one set for the capstan servo motor. The capstan servo electronics is contained on a separate PWA and is located adjacent to the transport control and tape timer PWAs (Figure 1-4). The reel motor MDAs do not require periodic adjustment. If a reel motor or any electronic component associated with the reel motor or its MDA is replaced, perform the following procedure. Refer to Figure 5-2.

1. Remove the MDA PWA from its connector and reinstall it using the appropriate extender board, part no. 4050801-01.
2. Set the stop supply (R3) and stop takeup (R6) potentiometers on transport control PWA fully clockwise. See Figure 5-3.

NOTE

Potentiometers R3 and R6 are four-turn devices without end stops. To insure that the full clockwise position is found, turn the shaft four full turns.

3. Connect oscilloscope probe to terminal E1 or E2 with ground to E3. Apply power to the transport and select the fast forward mode. Adjust R15 until the waveform peaks on the oscilloscope display just cease to clip (minimum amplitude is 1.5 Vp-p).
4. Press STOP.
5. Move the oscilloscope probe to terminal E5 or E4 and select the rewind mode. Adjust R16 in the same manner as R15 in step 3.
6. Remove power from the recorder/reproducer, disconnect the oscilloscope, remove the extender board, and replace the MDA PWA into its connector.
7. Perform the *Transport Control* procedures following paragraph 5-15.

5-15. Transport Control

The transport control electronics do not require periodic adjustment. If the transport does not function properly, refer to *Troubleshooting*, paragraph 5-53, for probable cause and remedy. If any electronic components or mechanical components in the transport control PWA or the transport mechanism are replaced, perform the following procedures as necessary to ensure correct operation.

NOTE

This procedure covers transport control PWA No. 4050864 only. Alignment procedures for the earlier version, PWA No. 4050706, are found in Appendix B.

5-16. Preliminary Setup. Perform the following procedures to prepare the transport control and transport mechanism for normalizing and tension adjustments.

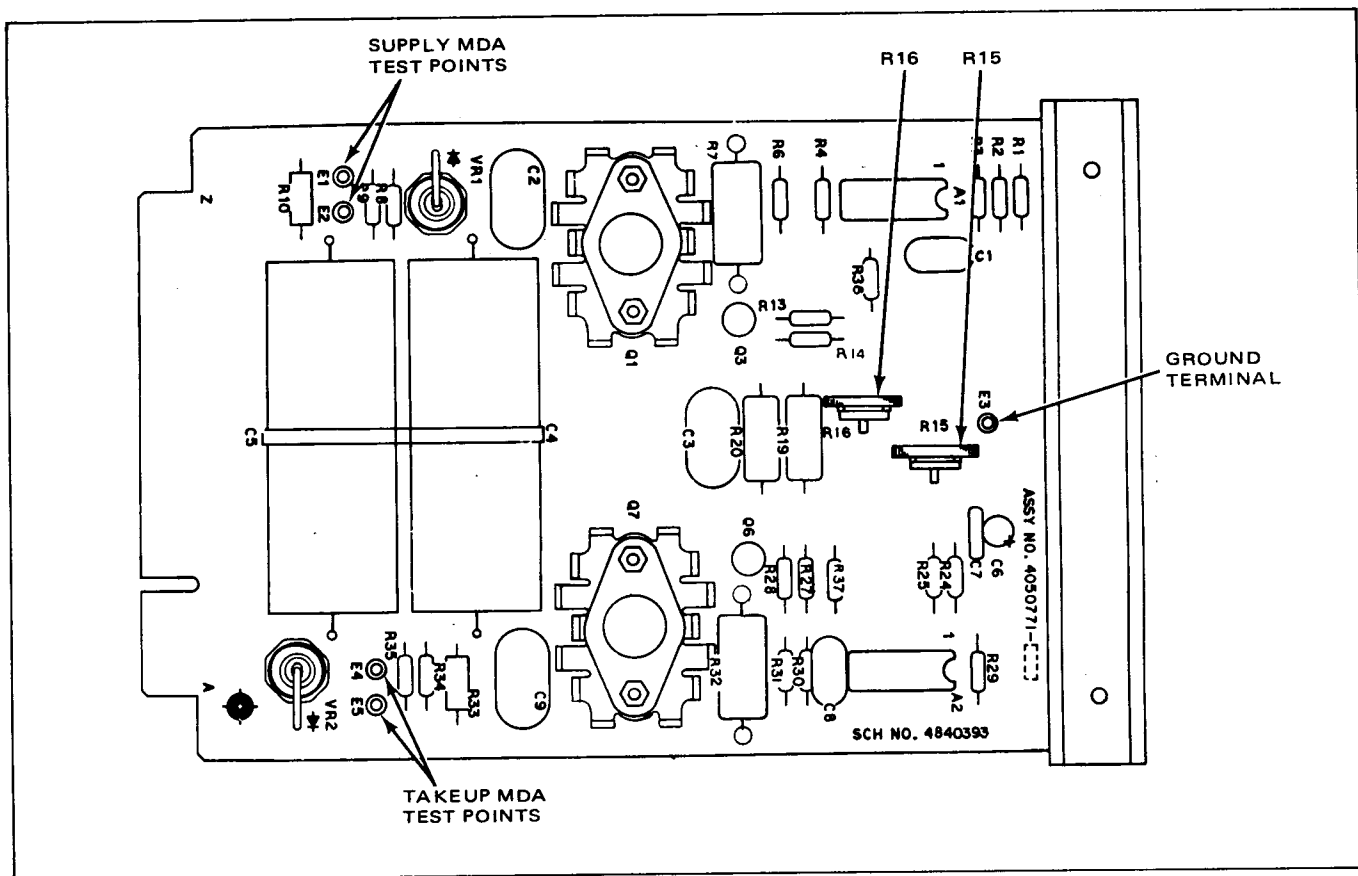

Figure 5-2. MDA PWA Test Point Location

1. Remove power from the recorder/reproducer.
2. Check calibration of tension sensor arm in accordance with the *Tension Sensor Arm Calibration* procedure, paragraph 5-17.
3. Remove the transport control PWA (Figure 5-3) from its connector and reinstall it using an extender board, part no. 4050695-04.
4. Referring to Figure 5-3, position potentiometers R1 through R8 and R10 full counterclockwise; R14, R15, and R34 to mid-position.

NOTE

All potentiometers except R34 are four-turn devices with clutched end stops. To insure that a potentiometer is positioned

fully counterclockwise, turn it four full turns. To find a mid-position setting, turn the potentiometer four full turns in one direction, then two full turns in the opposite direction.

5. Secure the end-of-tape arm out of the tape path using masking tape, but do not actuate the tape-threading switch.

NOTE

Reel servo normalizing and tension adjustments are affected by the power supply voltages. Ensure that power supply voltages are within tolerances prior to performing the following normalizing and tension adjustment procedures. Refer to the *Power Supply Adjustment* procedures, paragraph 5-8.

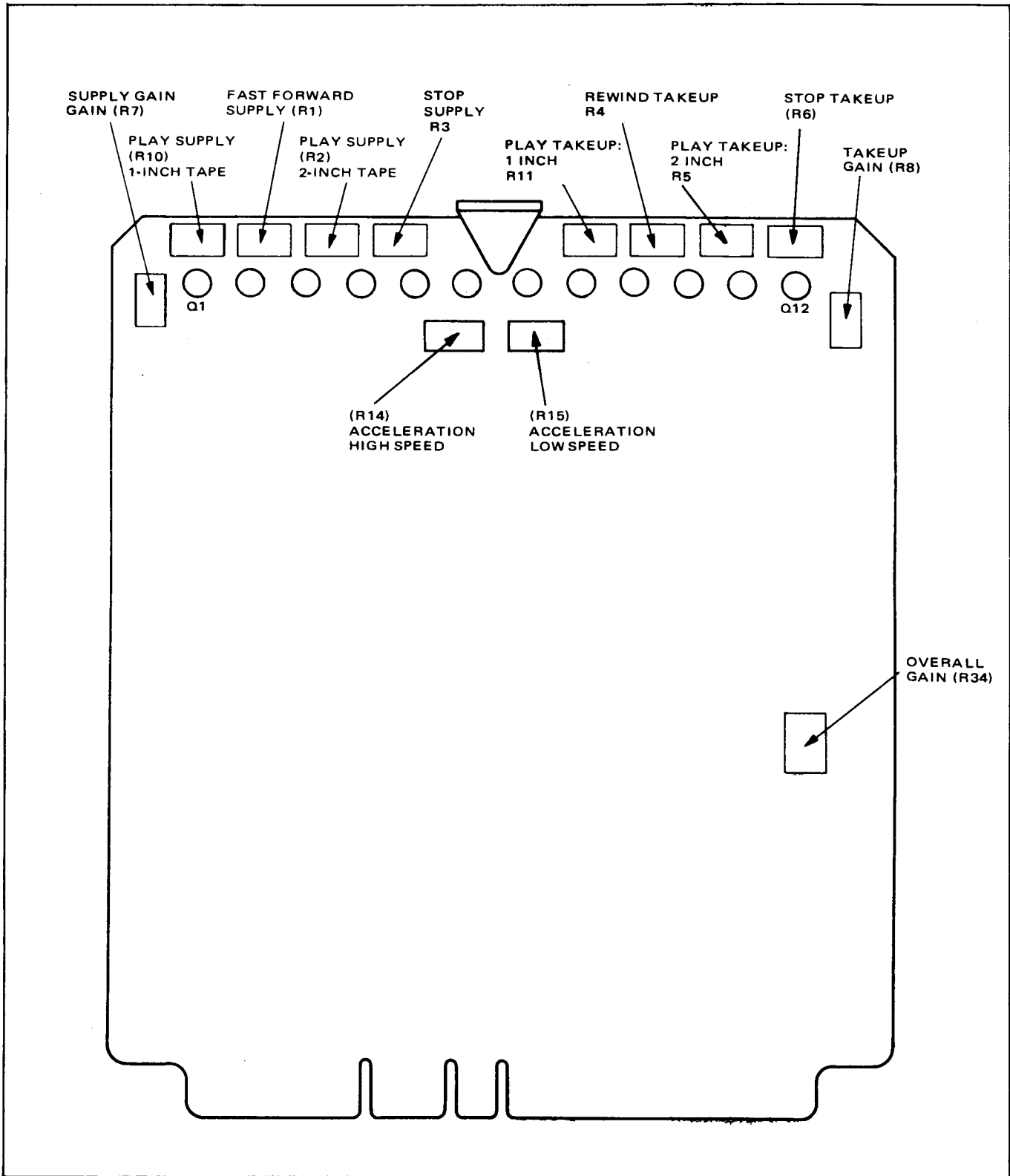

Figure 5-3. Transport Control PWA, Control Locations

5-17. Tension Sensor Arm Calibration. Check the tension sensor arm calibration as follows:

1. Remove power from the recorder/reproducer and remove tape from the area of the tension sensor arm.
2. Using a 30-ounce spring gauge, pull the tension sensor arm as shown in Figure 5-4. The alignment surface of the tension sensor arm must align with the alignment marks on the tension sense label when the spring gauge indicates 4 ounces (one-inch tape) or 8 ounces (two-inch tape).

If the tensions specified in step 2 above, are not present, recalibrate the tension sensor arm as follows:

1. Remove the screw holding the tension sensor cover, remove the cover, and loosen the two screws that retain the tension sensor mounting block (see Figure 5-4).
2. Reposition the mounting block such that the shutter opening is centered between the two photo cells with a tension of 8 ounces applied as shown in Figure 5-4.

NOTE

The repositioning of the tension sensor arm may be most easily accomplished by two persons; one to maintain 8 ounces of pressure on the tension sensor arm, and the other to readjust the mounting block.

3. When the correct position and tension have been achieved, tighten the two tension sensor mounting block screws.
4. Recheck the tension sensor arm calibration as outlined in steps 1 and 2 of the preceding paragraph and re-mark the tension sense label as necessary.

NOTE

The 4 and 8 ounce settings of the tension sensor arm correspond to 3¼ and 6½ ounces of tape tension, respectively, at the supply reel.

5. Install the tension sensor cover and secure with one screw.

5-18. Normalizing Reel Servos. Normalize reel servos as follows:

1. Apply power to the recorder/reproducer.
2. Hold the supply reel with light finger pressure and adjust the supply gain potentiometer R7 slowly clockwise until the torque is felt; then back R7 off until the torque reduces to zero (no reel motion).
3. Press the REWIND button and, while holding the takeup reel with light finger pressure, turn the takeup gain potentiometer R8 slowly clockwise until the torque is felt; then back R8 off until the torque reduces to zero (no reel motion).
4. Remove power from the transport and remove the masking tape from the end-of-tape arm.

5-19. Tension Adjustments. Since tension adjustments are dependent on associated gain and normalizing adjustments, it is advisable to check all tensions after making any adjustments to the transport control electronics. Check and adjust transport tensions according to the following procedures.

Stop Tension -- Not Using Tension Meter. To set stop tension without the use of a tension meter, proceed as follows:

NOTE

The tension sensor arm is calibrated at the factory. If the position of the tension sensor arm (Figure 5-5) is changed, or the adjustment specified in step 2 of the following *Stop Tension* adjustment procedure cannot be achieved, perform the *Tension Sensor Arm Calibration* procedure, paragraph 5-17.

1. Thread a reel of tape onto the transport (see Figure 5-5), using the largest reel size expected to be used (up to 16 inches). Wrap only two turns of tape onto the takeup reel.

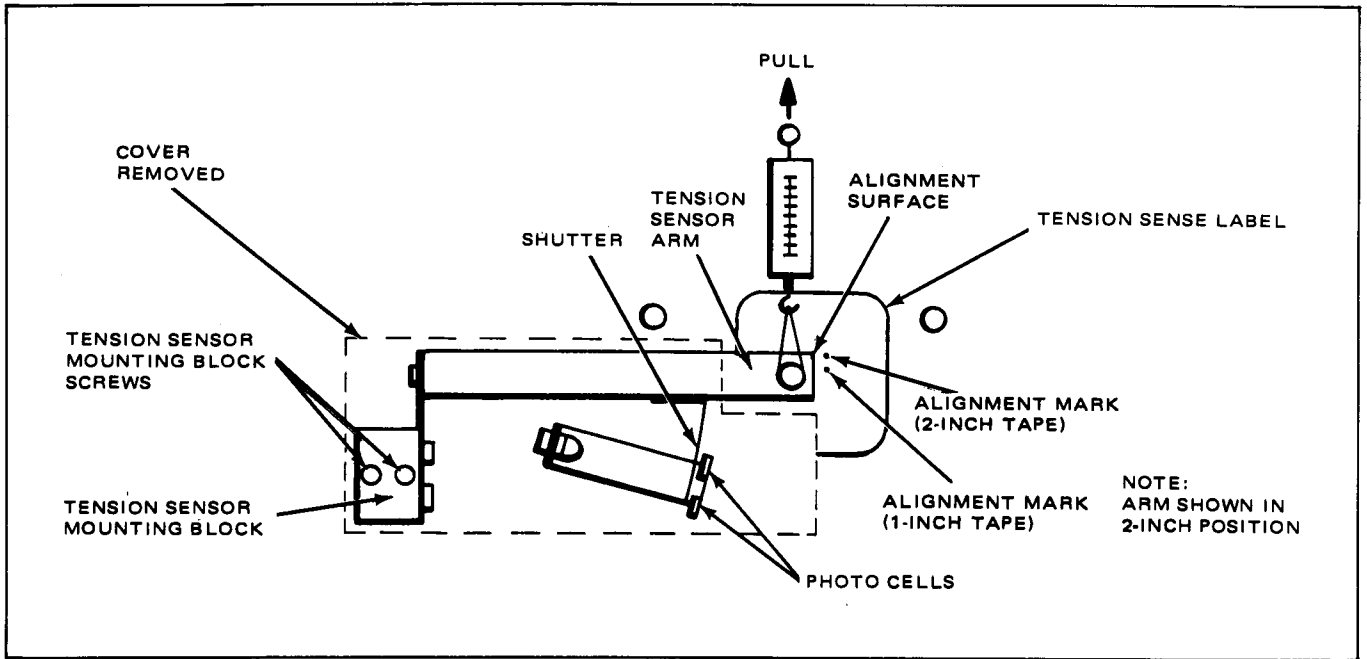

Figure 5-4. Tension Sensor Arm Calibration

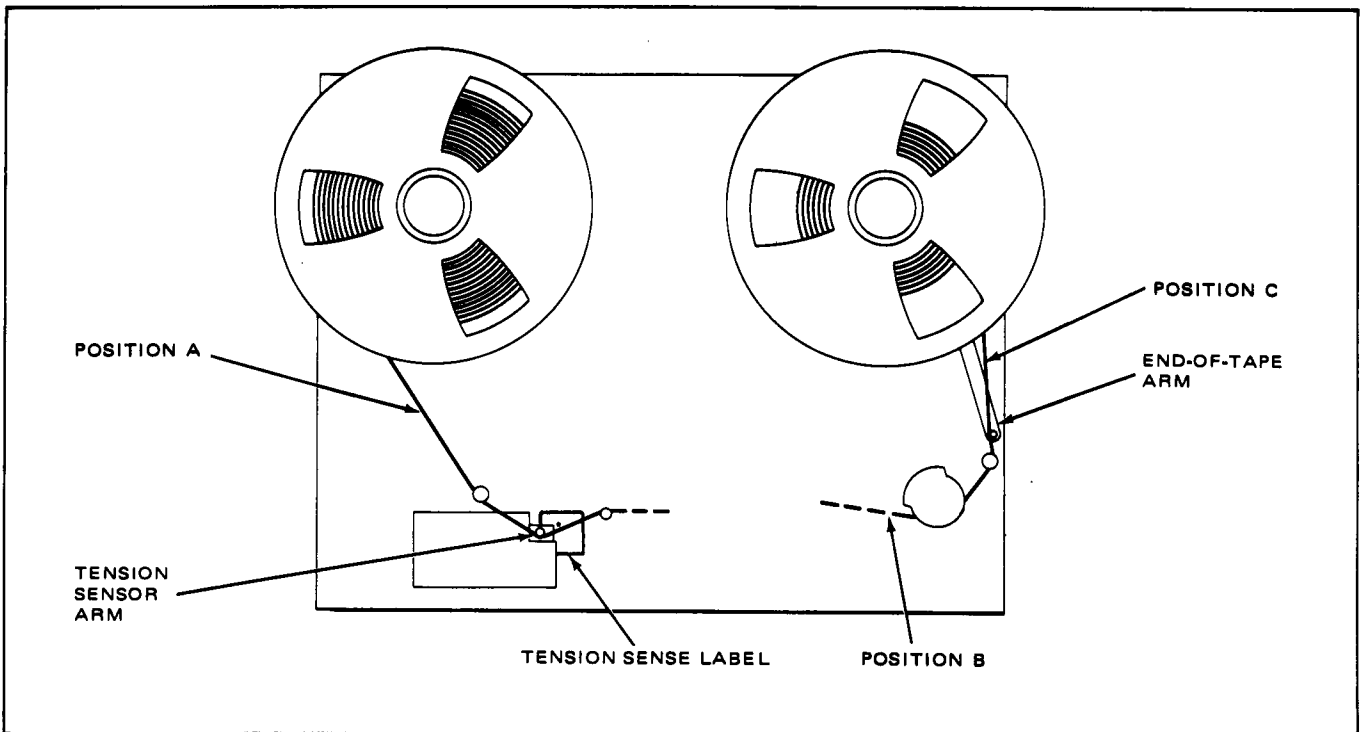

Figure 5-5. Tape Tension Adjustments

2. While holding the takeup reel to restrain movement, apply power to the recorder/reproducer and momentarily depress the LIFT DEFEAT switch to disengage the reel brakes. Adjust the stop supply tension potentiometer (R3) until the alignment surface of the tension sensor arm (Figure 5-6) is aligned with the one-inch or two-inch alignment mark, according to tape width on the tension sense label.

NOTE

If the transport exhibits a tendency to oscillate during these adjustments, re-adjust the overall gain potentiometer (R34) until the oscillations cease. This adjustment should be made with a minimum tape pack on the supply reel, using the smallest available reel.

3. Momentarily depress the LIFT DEFEAT switch to release the reel brakes. With maximum tape pack on the supply reel, adjust the stop takeup potentiometer (R6) until the tension on the takeup reel increases sufficiently to cause the tape to move forward. Then, decrease tension until the tape just stops and exhibits no tendency to move forward. This balances the stop mode tensions and the tape should not move in the stop mode regardless of tape pack.

Stop Tension – Using Tension Meter. If a tape tension meter, Tentel Model T2-H20-2 or equivalent, is available, the following procedure, may be used to set stop tension.

1. Shuttle the tape so that there is approximately the same amount of tape on each reel, and place the system in the stop mode.
2. Press the LIFT DEFEAT switch to release the brakes.
3. Insert the tape tension meter in position A as shown in Figure 5-5. Adjust R3 (Figure 5-3) for a tension indication of 6.5 ± 0.5 oz (two-inch tape) or 3.5 ± 0.5 oz (one-inch tape).
4. Insert the tape tension meter in position C as shown in Figure 5-5. Adjust R6 (Figure 5-3)

for a tension indication of 6.5 ± 0.5 oz (two-inch tape) or 3.5 ± 0.5 oz (one-inch tape).

NOTE

The above adjustments result in relatively high tape tension in the stop mode. If desired, for easier tape handling and editing purposes, R3 and R6 (Figure 5-3) may be adjusted so that the tension is approximately one-half of normal, or less, as indicated on the tape tension meter. Check that proper balance is maintained so that the tape does not tend to move in either direction during stop mode.

Play Tension – Not Using Tension Meter. Set the play tension as follows:

1. Push the end-of-tape arm toward the center of the transport releasing reel tension and applying the reel motor brakes. Remove the tape from between the capstan shaft and the pinch roller and route tape around outside of capstan shaft. Then, take up the slack in the tape.
2. Depress the PLAY pushbutton while holding the takeup reel to prevent movement.
3. Adjust the play supply potentiometer R2 (for two-inch tape) or R10 (for one-inch tape) until the tension sensor arm aligns with the alignment mark for the appropriate tape size on the tension sense label under the tension sensor arm (Figure 5-6).
4. Release the takeup reel and adjust play take-up potentiometer R5 (for two-inch tape) or R11 (for one-inch tape) until tensions are equal on both reels. This condition will exist when the tape shows no tendency to move in either direction.
5. Depress STOP pushbutton.

Play Tension – Using Tension Meter. If a tape tension meter, Tentel Model T2-H20-2 or equivalent, is available, the following procedure may be used to set play tension.

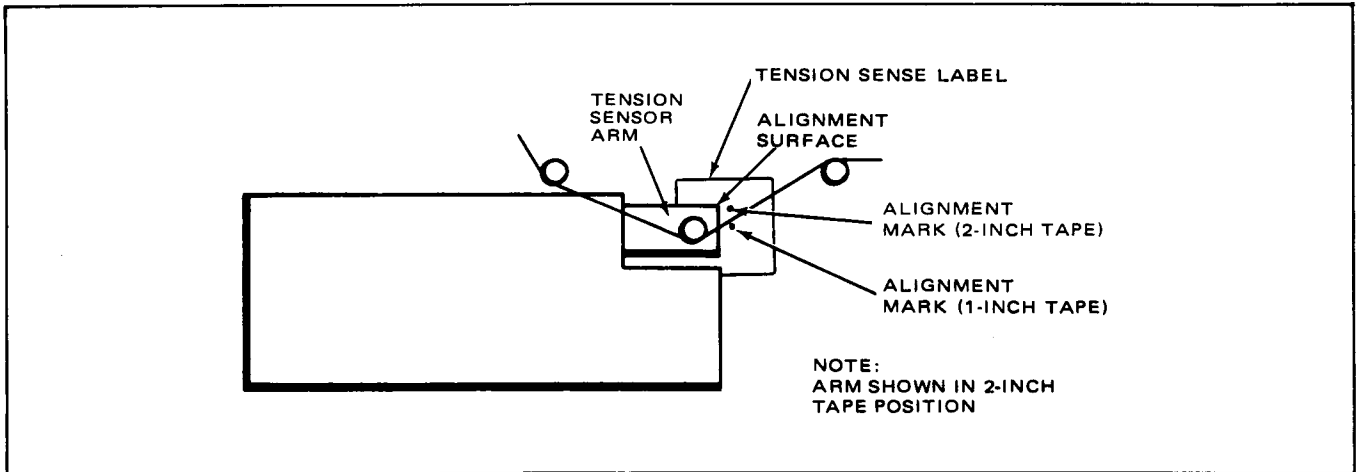

Figure 5-6. Positioning Tension Sensor Arm

1. Shuttle the tape so that there is approximately the same amount of tape on each reel.
2. Insert the tension meter in position A as shown in Figure 5-5 and depress the PLAY pushbutton. Adjust potentiometer R2 (two-inch tape) or R10 (one-inch tape) for a tension indication of 6.5 ± 0.5 oz (two-inch tape) or 3.5 ± 0.5 oz (one-inch tape).
3. Insert the tension meter in position B as shown in Figure 5-5. Adjust potentiometer R5 (for two-inch tape) or R11 (for one-inch tape) for a tension indication of 12 ± 1 oz (two-inch tape) or 6 ± 1 oz (one-inch tape).

Play Tension — Acceleration Adjustment. Perform the following procedure after setting play tension by either method above to verify correct operation.

1. Make a 90-second recording at the transport high speed using a 3-kHz test signal at normal operating level at the beginning of a reel.
2. Monitor the 3-kHz output of the channel just recorded. Press the PLAY and STOP buttons alternately. When the PLAY button is pressed, the reproduced tone should not shift in frequency as the tape reaches normal speed. If the tone shifts in frequency, adjust R14 as follows.

If the tape underspeeds, adjust R14 clockwise, if the tape overspeeds, adjust R14 counterclockwise until the frequency shift no longer occurs when the play mode is entered.

3. Repeat steps 1 and 2 at the transport low speed and adjust R15 as follows:

If the tape underspeeds, adjust R15 clockwise, if the tape overspeeds, adjust R15 counterclockwise until the frequency shift no longer occurs when the play mode is entered.

Shuttle Tension. Adjust the shuttle tension as follows:

1. Shuttle the tape so that approximately two-thirds of the tape is on the supply reel.
2. Depress the REWIND pushbutton. After the tape has accelerated to maximum speed, adjust rewind takeup potentiometer R4 such that the tension sensor arm (Figure 5-6) aligns with the alignment mark on the tension sense label for the appropriate tape size.
3. Shuttle the tape so that two-thirds of the tape is on the takeup reel. Depress the FAST FWD pushbutton and adjust fast forward supply potentiometer R1 such that the tape accelerates at the desired rate.

NOTE

The shuttle tension settings outlined above result in optimum tape pack on a reel and maximum tape timer accuracy. However, for more rapid fast forward and rewind shuttling, potentiometers R4 and R1 may be adjusted for less hold-back tension as desired.

5-20. Capstan Servo System

The capstan servo system does not require periodic adjustment. If the servo motor or any electronic component in the system is changed, perform the following adjustment procedures.

1. Remove the capstan servo PWA from its connector and reinstall it using extender board, part no. 4050695.
2. Attach an oscilloscope probe to the PWA test point TP2 (see Figure 5-7).
3. Set the oscilloscope input to accept an input signal of up to +12 Vdc.
4. Ensure that dummy plug (part no. 4050710-01) is connected to the VARIABLE SPEED connector at the recorder/reproducer rear.
5. On the capstan servo PWA, set R19 (gain) and R45 (duty cycle) potentiometers to approximately mid-range.
6. Apply power to the recorder/reproducer.
7. Place the transport in play mode.
8. On the servo PWA, adjust R45 for a 50% duty cycle (equal width positive and negative pulses). See Figure 5-8.
9. On the servo PWA, adjust R19 for a minimum jitter at the trailing edge of the positive waveform at TP2 (see Figure 5-8).
10. Depress STOP pushbutton and turn off recorder/reproducer power.
11. Remove extender board and reinstall capstan servo PWA in its connector.

5-21. Search-to-Cue/Tape Timer

The search-to-cue and tape timer electronics and adjustments are factory set and do not require periodic adjustment. In the event that a component is changed in the search-to-cue and tape timer PWA, perform the following checkout and adjustment procedures.

5-22. Checkout. Check out the search-to-cue and tape timer as follows.

1. Remove the search-to-cue and tape timer PWA from its connector in the transport control chassis and reinsert it using the appropriate extender board, part no. 4050695-04.
2. Thread a tape onto the transport and apply power to the recorder/reproducer.
3. Depress the CUE and DISPLAY RESET pushbuttons on the timer assembly.
4. Measure the voltage at pin 7 of A28 and adjust R68 (trajectory threshold adjustment) as necessary, for an indication of +7.8 Vdc.
5. Shuttle the tape a minimum of 5 seconds in the forward direction and depress the SEARCH pushbutton.
6. Observe that the tape transport returns the tape to the cue point (timer zero indication) smoothly with no overshoot.

5-23. Adjustment. Adjust search-to-cue and tape timer as follows:

1. If the tape overshoots the cue point, readjust R68 slightly counterclockwise and repeat steps 5 and 6 in the checkout procedure above. Repeat as necessary to eliminate the overshoot condition.
2. If the tape stops short of the cue point and then moves in a series of stops and starts, re-adjust R68 slightly clockwise and repeat steps 5 and 6 in the checkout procedure above. Repeat as necessary to eliminate the stop and start condition.

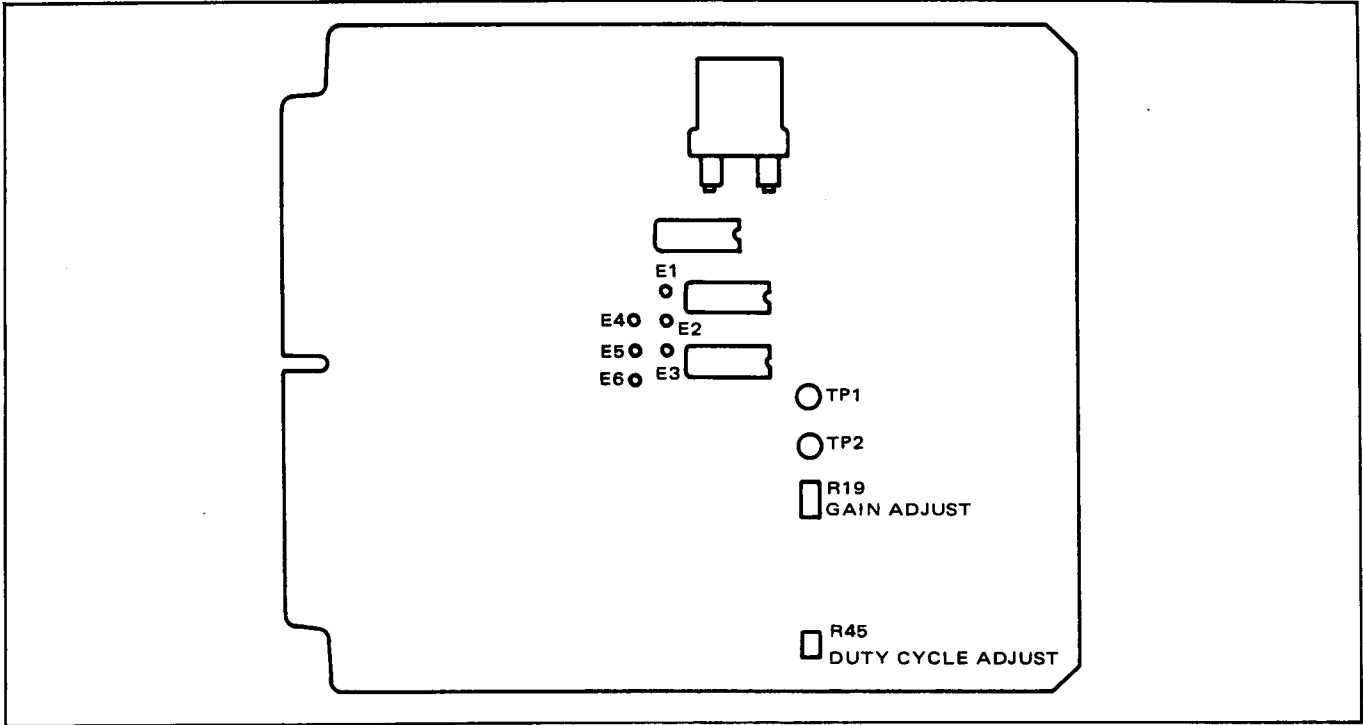

Figure 5-7. Servo PWA Test Points and Adjustments

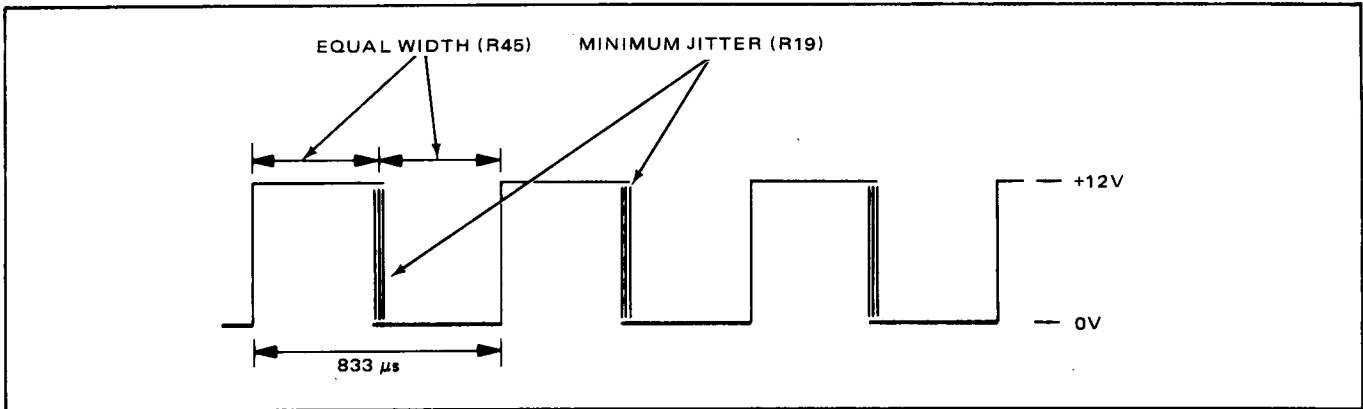

Figure 5-8. Waveform at TP2 on Servo PWA

3. With power off, remove the PWA from the extender board and reinsert it into its connector in the transport control chassis.

5-24. Alignment of Photo-Isolators. If a component of the tach preamplifier is replaced, the photo-isolators must be mechanically realigned.

To realign the photo-isolators, adjust the position of the tach preamplifier PWA as follows:

1. With power off, remove the search-to-cue and tape timer PWA (Figure 1-4) and reinstall it using the appropriate extender board, part no. 4050695-04.

2. Position the tach preamplifier at approximately mid-range of its adjustment as shown on Figure 5-9.
3. Apply power to the recorder/reproducer.
4. Connect oscilloscope to pin 4 of the tach preamp assembly and, while manually spinning the tape timer idler, adjust R3 for a 1Vp-p display. Remove the oscilloscope and connect it to pin 1. Adjust R2 for a 1Vp-p display.
5. Connect dual trace oscilloscope probes to pins 4 and 6 of flip-flop A1 on the search-to-cue and tape timer PWA. Adjust the oscilloscope to trigger on one input probe only.
6. Manually spin the timer assembly idler in the tape forward direction.
7. While the idler is spinning, observe the oscilloscope display and adjust the position of the tach preamplifier such that the leading edges of the display are 90° out of phase as shown in Figure 5-10.

NOTE

The pulse widths should be approximately equal. If the pulse widths vary such that the leading or trailing edges are coincident at any time while the idler is spinning, repeat step 4.

8. Depress the DISPLAY RESET pushbutton and continue to rotate the tape timer idler in the tape forward direction, and observe that the display is counting up. If the display counts down with the tape idler rotating in the tape forward direction, the wrong 90° phase point has been selected. Reposition the tach preamplifier in or out until the 90° phasing shown in Figure 5-10 is obtained and the display counts up.

NOTE

If it is not possible to obtain the correct 90° phasing relationship within the limits of the tach preamp PWA travel, the photo-isolators must be realigned

slightly closer together or farther apart. This may be accomplished by carefully bending the leads of either photo-isolator and repositioning it laterally to obtain the proper spacing required to obtain the correct 90° phasing.

9. Tighten the tach preamplifier adjustment screws, and reassemble and reinstall the timer assembly as shown in the *Removal and Replacement* procedure, paragraph 5-73.
10. Reconnect the oscilloscope to A1-4/6 as in step 5. Thread a tape onto the transport and select the fast forward mode. Observe the displacement of the pulses with reference to Figure 5-10.
11. Place the transport in the rewind mode and again observe the pulses. The amount of displacement observed should be approximately equal in the fast forward and the rewind modes.

CAUTION

THERE MUST BE NO COINCIDENCE OF THE PULSE LEADING OR TRAILING EDGES IN THE SHUTTLE MODES, AS THIS WILL RESULT IN A STOPPED SIGNAL BEING GENERATED BY THE MOTION SENSE CIRCUITRY WHICH CAN CAUSE PINCH ROLLER ACTUATION AND SUBSEQUENT TAPE DAMAGE WHEN THE TAPE IS THREADED NORMALLY.

12. If the pulse edge displacements observed in steps 10 and 11 are not approximately equal, or if there is coincidence between pulses, perform the following:
 - a. Stop the tape motion and remove the tape from the tape timer idler.
 - b. Disassemble the tape timer assembly from the transport base.
 - c. Readjust the tach preamplifier slightly in one direction.
 - d. Reassemble the tape timer assembly onto the transport base.

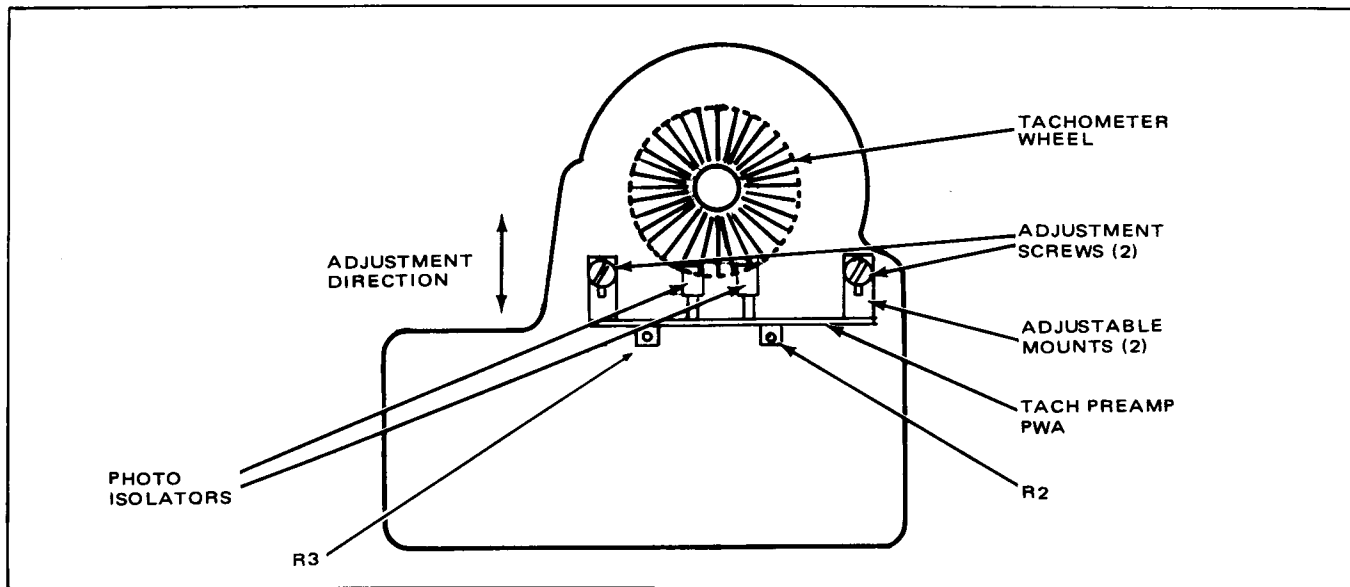

Figure 5-9. Tachometer Preamp Adjustment

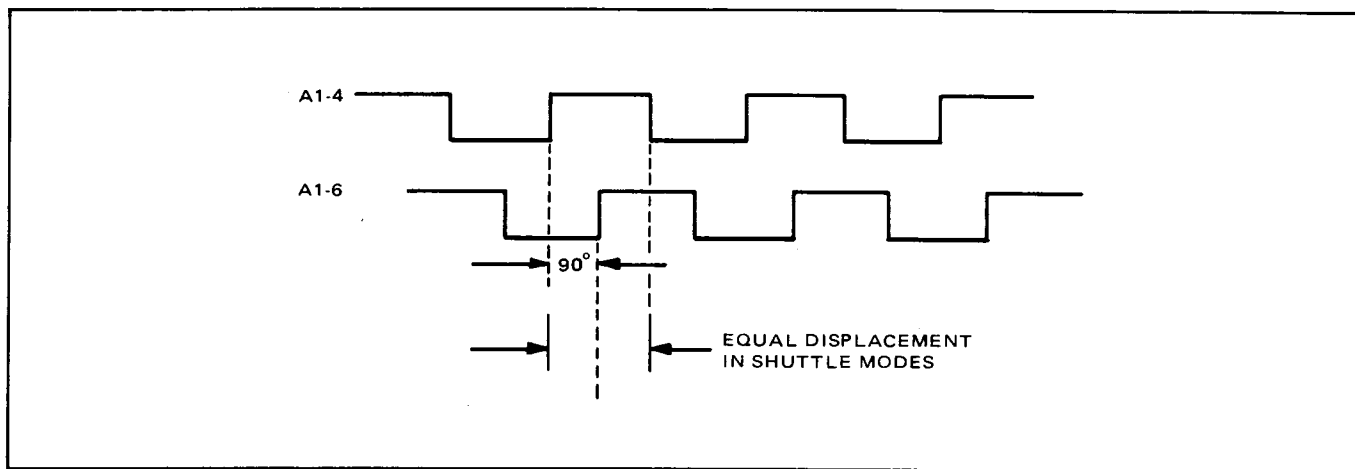

Figure 5-10. Tachometer Preamp Adjustment Waveforms With Tape Moving in the Forward Direction

- e. Recheck the pulse edge displacement as described in steps 7 and 8.
- f. Repeat steps *a* through *e* as necessary to achieve equal pulse displacement in both tape directions at shuttle speed.
13. Remove the oscilloscope probes from pins 4 and 6 of A1 and connect a probe to pin 6 of A5.
14. Shuttle the tape in both directions and observe that the level at pin 6 of A5 is in a

low state in the forward direction, and is in a high state in the rewind direction. There should be no dropouts as the tape accelerates. Dropouts indicate an instantaneous pulse-edge coincidence. If dropouts are present, repeat steps 5 through 12.

15. Depress STOP pushbutton.

5-25. MECHANICAL ADJUSTMENTS

5-26. Takeup Reel Brake Adjustment

The brake system stops reel rotation and maintains tape tension when the recorder/reproducer power

is removed while in any operating mode. A brake differential is necessary to maintain tension while stopping. The brake force is therefore higher for the tape feeding reel in every case. Each reel has a high brake adjustment (tape feeding) and a low brake adjustment (tape takeup). The locations of the adjustment nuts are shown in Figure 5-11; the tensions for high and low brake conditions are given in Table 5-2. Braking functions are checked and adjusted with power off and no tape installed.

5-27. Brake Check and Adjustment. Check operation of the takeup reel brakes as follows:

1. Wrap 30 inches of nylon cord counterclockwise on the takeup reel, and secure the free end to a 30-ounce spring gauge.

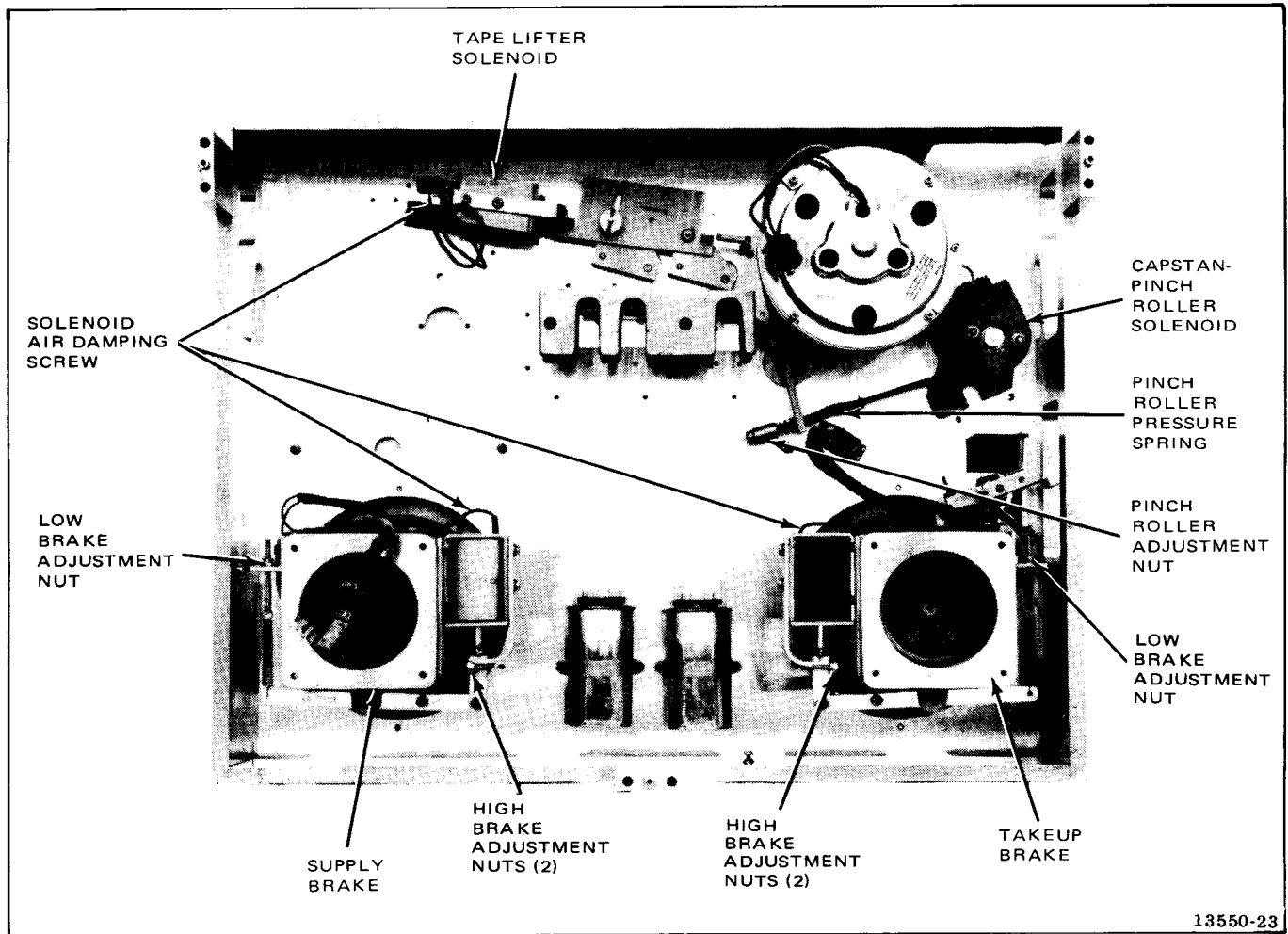

Figure 5-11. Transport Adjustment Points

Table 5-2. Transport Brake Torques

| SUPPLY REEL | | | TAKEUP REEL | |
|--------------------|-----------------------|--------------------------|------------------------|-------------------------|
| TRANSPORT SIZE | LOW BRAKE REWIND (CW) | HIGH BRAKE FORWARD (CCW) | HIGH BRAKE REWIND (CW) | LOW BRAKE FORWARD (CCW) |
| Two-Inch Transport | 2 ±1/4 lb. | 4 ±1/4 lb. | 4 ±1/4 lb. | 2 ±1/4 lb. |
| One-Inch Transport | 2 ±1/4 lb. | 3 ±1/4 lb. | 3 ±1/4 lb. | 2 ±1/4 lb. |

2. Hold the spring gauge parallel to the transport base and as close as possible to the reel, then pull the spring gauge slowly to measure tension.
3. Tap the takeup reel to ensure a correct reading, then pull the spring gauge slowly and read the scale indication. Repeat this procedure until the scale indication has been the same several times. The scale should indicate the value given in Table 5-2 for the takeup reel low brake.
4. Wrap the nylon cord clockwise on the takeup reel and secure the free end to a 10-pound spring gauge (see Table 5-1).
5. Hold the spring gauge parallel to the transport base and as close as possible to the reel, then pull the spring gauge slowly to measure tension.
6. Tap the takeup reel to ensure a correct reading, then pull the spring gauge slowly and read the scale indication. Repeat this procedure until the scale indication has been the same several times. The scale should indicate the value given in Table 5-2 for the takeup reel high brake.

If the tension was not correct in either direction of rotation, adjust the takeup reel brake in that direction following steps 7 through 10.

7. Adjust the low brake adjustment nut (Figure 5-11) to increase or decrease brake tension as necessary. (Clockwise rotation of the brake adjustment nut increases brake tension.)

8. Recheck the low brake tension as described in steps 1, 2, and 3.

NOTE

In the following step, ensure that both high brake adjustment nuts are adjusted equally to maintain even tension across the brake band surface.

9. Rotate the high brake adjustment nut on either side of the takeup reel brake solenoid (Figure 5-11) to increase or decrease brake tension as necessary. (Clockwise rotation of the brake adjustment nuts increases brake tension.)
10. Recheck the high brake tension as described in steps 4, 5, and 6.

5-28. Brake Solenoid Air Damping. The brake solenoid air damping screw indicated in Figure 5-11 (similar to that shown in Figure 5-13 for the tape lifter) quiets the brake mechanism and controls the brake operating speed. The optimum setting is for the screw to be engaged three turns. However, quieter, but slower, operation may be achieved by turning the screw in. The screw may be removed for fastest operation.

5-29. Supply Reel Brake Adjustment

The supply reel brakes are identical in operation to the takeup reel brakes and may be checked and adjusted using the same procedures described previously for the takeup reel brakes, except substituting the supply reel tension values as applicable. See Table 5-2.

5-30. Capstan Servo Motor

The capstan servo motor should be checked every three months for the first six months of operation, and every six months or 1500 hours of operation thereafter, according to the following instructions.

1. Remove the capstan servo motor from the transport as outlined in the *Removal and Replacement* procedure, paragraph 5-68.
2. Remove two screws which hold the magnet and brush assembly to the motor body.

NOTE

The magnet and brush assembly will be held closed even with the screws removed, due to the magnets in the magnet and brush assembly.

CAUTION

IN THE FOLLOWING STEP, THE FLAT-BLADED TOOL MUST NOT PROJECT MORE THAN 1/4 INCH INSIDE THE MAGNET AND BRUSH ASSEMBLY OR SERIOUS DAMAGE TO THE ROTOR MAY RESULT.

3. Carefully pry the magnet and brush assembly away from the motor body with a flat-blade tool (see Figure 5-12).
4. Wipe clean all carbon deposits accumulated on the magnet and brush assembly, rotor surface, etc.
5. If the rotor surface where the brushes make contact is contaminated, refinish that surface lightly using No. 4/0 sandpaper.
6. Wipe the rotor surface clean using head cleaner.
7. If the rotor was removed for cleaning, use a 0.010-inch feeler gauge between the rotor and the magnet return plate (see Figure 5-12) while tightening the rotor setscrews. Remove the feeler gauge and ensure that the rotor moves freely without binding.

8. On the magnet and brush assembly, check that the brush project is not less than 0.130-inch above the magnet surface. If the brushes do not project at least this amount, new brushes (Ampex part no. 592-447) or a new magnet and brush assembly (Kit part no. 4030414-01) must be installed. Install new brushes in the backplate assembly as follows:

NOTE

In the following step, exercise care during the brush removal operation so the brush springs are not lost.

- a. Remove the old brushes by separating the crimp connector or unsoldering as applicable.

NOTE

When soldering the brush pigtail to the crimp connector, ensure that the pigtail is sufficiently long to permit full brush travel in the brush holder.

- b. Install the new brushes in the brush holders, and solder each brush pigtail such that the pigtail length restrains the brush in the brush holder.
9. Carefully replace backplate assembly and two screws.
10. Reinstall the capstan servo motor in the transport as outlines in the *Removal and Replacement* procedure, paragraph 5-68.

5-31. Tape Lifter Assembly Adjustments

The tape lifter assembly is factory set and does not require periodic adjustment. However, if a tape lifter assembly component is changed or it is desired to alter the distance that the tape lifters move the tape from the heads, perform the following procedures.

1. Remove the tension sensor assembly cover to provide access to the two hex head cap screws that secure the tape lifter solenoid (beneath the transport base) to the transport base.

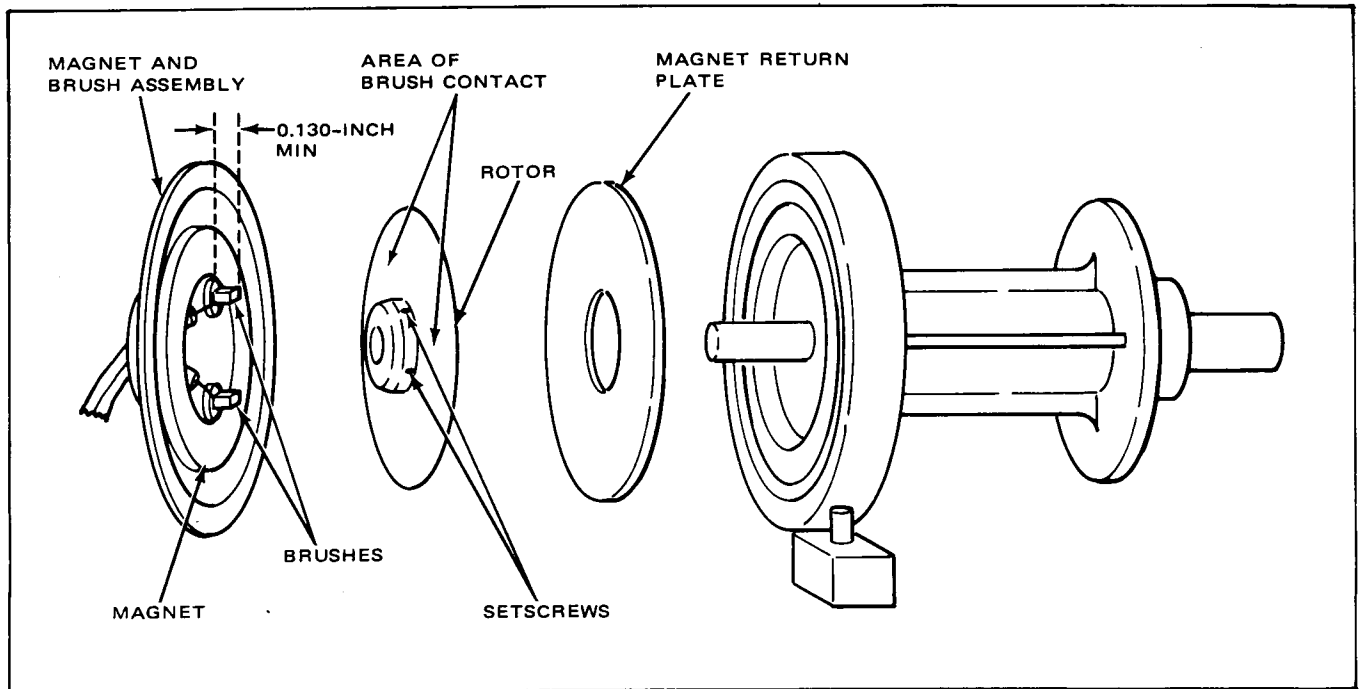

Figure 5-12. Servo Motor Maintenance

2. Loosen the two cap screws that secure the tape lifter solenoid.
3. Remove the left side panel from the recorder/reproducer frame. The tape lifter solenoid may be reached through an access hole in the side of the transport base.
4. Thread a tape on the transport.
5. Turn off the recorder/reproducer power and manually actuate the tape lifter solenoid and adjust its position left or right (see Figure 5-13) as necessary, such that the right-hand tape lifter arm moves the tape approximately 0.1 inch from the reproduce heads. Retighten the two cap screws and reinstall the tension sensor assembly cover.
6. With the tape lifter solenoid manually actuated, loosen the adjustable pivot thumbscrew (see Figure 5-13) and adjust its position such that the left-hand tape lifter arm moves the tape approximately 0.1 inch from the record heads, but so that the tape does not contact the erase heads.
7. Recheck the distance between the tape and the reproduce heads and readjust as necessary as described in step 6, above.
8. Reinstall the left side panel on the recorder/reproducer frame.

NOTE

The preceding steps provide optimum positioning of the tape lifter arms when actuated. If desired, the tape lifter arms may be readjusted either in or out for special applications.

5-32. Tape Lifter Solenoid Air Damping. The tape lift solenoid air damping screw shown in Figure 5-13 quiets the lifter mechanism and controls the lifter speed. The optimum setting is for the screw to be engaged three turns. However, quieter, but slower operation may be achieved by turning the screw farther in. The screw may be removed for fastest lifter operation.

5-33. Head Assembly

The head assembly is factory adjusted and is not field adjustable or repairable. If the head assembly

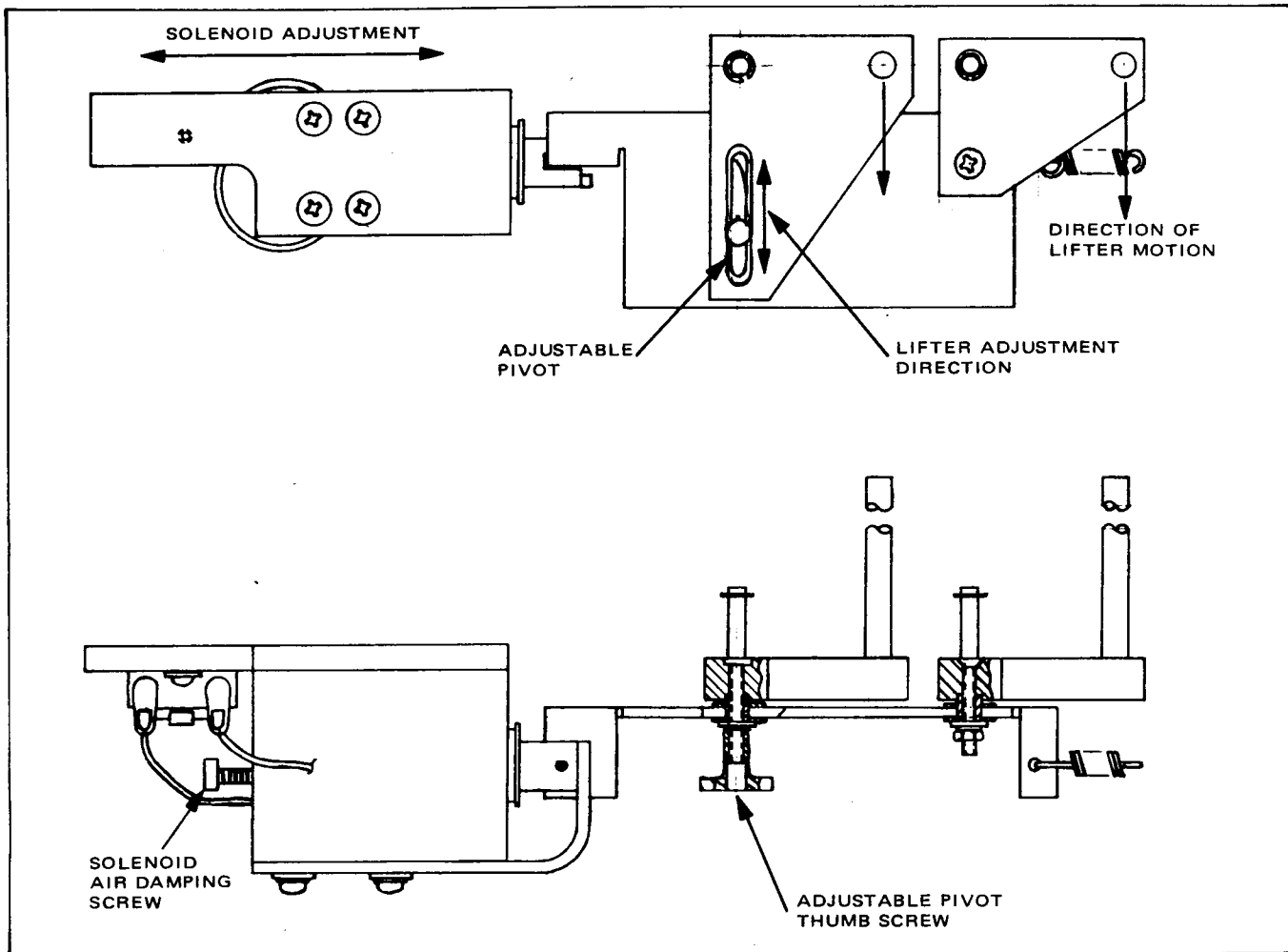

Figure 5-13. Tape Lifter Adjustment

is replaced, it may be desirable to remove the scrape-flutter idler from the old head assembly and install it on the new head assembly. Removal and installation of the scrape-flutter idler is accomplished by removing the one securing screw and using it to install the idler into the new head assembly. The scrape-flutter idler is adjustable to a small degree. Adjust the scrape-flutter idler as follows:

1. Thread tape onto the recorder/reproducer, and apply power.
2. Loosen the scrape-flutter idler securing screw slightly and exert a slight pressure on the scrape-flutter idler mount such that the idler just touches the tape.

3. While holding the idler in this position, tighten the securing screw.

5-34. Pinch Roller

The pinch roller force against the capstan is determined by the capstan pinch roller pressure spring. This force is adjusted by a locknut which compresses the pinch roller pressure spring as shown in Figure 5-11. Check and adjust the pinch roller pressure whenever the capstan motor has been moved or when any parts associated with the capstan pinch roller have been replaced.

- 5-35. **Check.** Check the capstan pinch roller pressure as follows:

1. Wrap a 12-inch piece of nylon cord or equivalent, around the pinch roller yoke as shown in Figure 5-14. Insert the hook of a 10-pound spring gauge (Table 5-1) in the cord loop.
2. Secure the end-of-tape arm in the on position, and secure the reel motors from turning.
3. Apply power to the recorder/reproducer and depress the PLAY pushbutton.
4. Measure the force required to eliminate the pinch roller/capstan contact as observed by cessation of pinch roller movement when it is moved away from the capstan by the spring gauge. This force should be 8-3/4 to 9-1/4 pounds.

5-36. Adjustment. If the pinch roller is not within the limits indicated in step 4, preceding, perform the following:

1. Adjust the pinch roller pressure spring locknut under the transport (Figure 5-11) as

required to obtain the correct pressure indication. (Turning the adjustment locknut clockwise increases spring pressure.)

2. Recheck the pinch roller pressure as indicated in the check paragraph preceding, and re-adjust as necessary for the correct pressure.
3. Release both reel motors and the end-of-tape arm.

5-37. End-of-Tape Arm

The end-of-tape arm is factory set and requires no periodic adjustment. If any end-of-tape arm component is replaced, readjust as follows:

1. Remove the recorder/reproducer right-side panel.
2. With the power off, allow the sensor arm to move to the end-of-tape position (resting on the inner stop pin). See Figure 5-15.

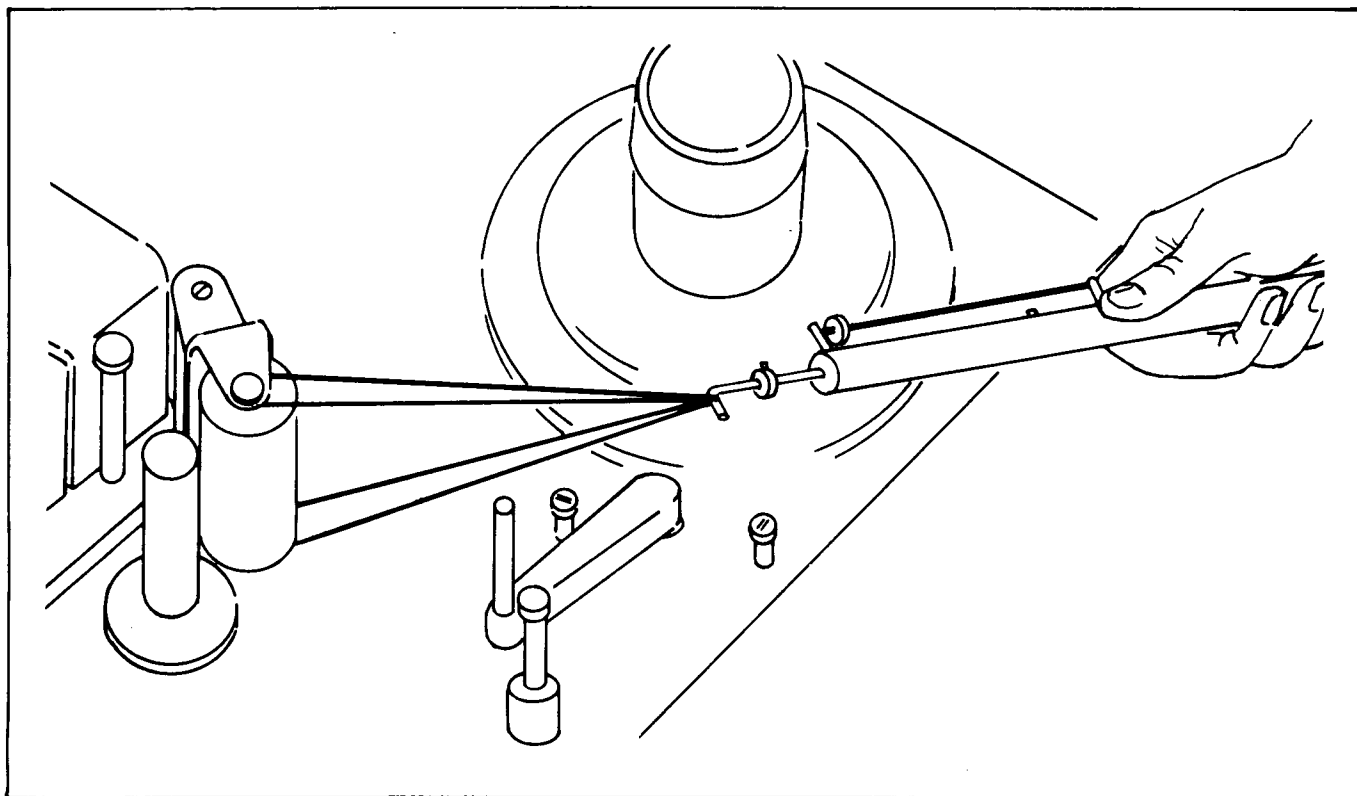
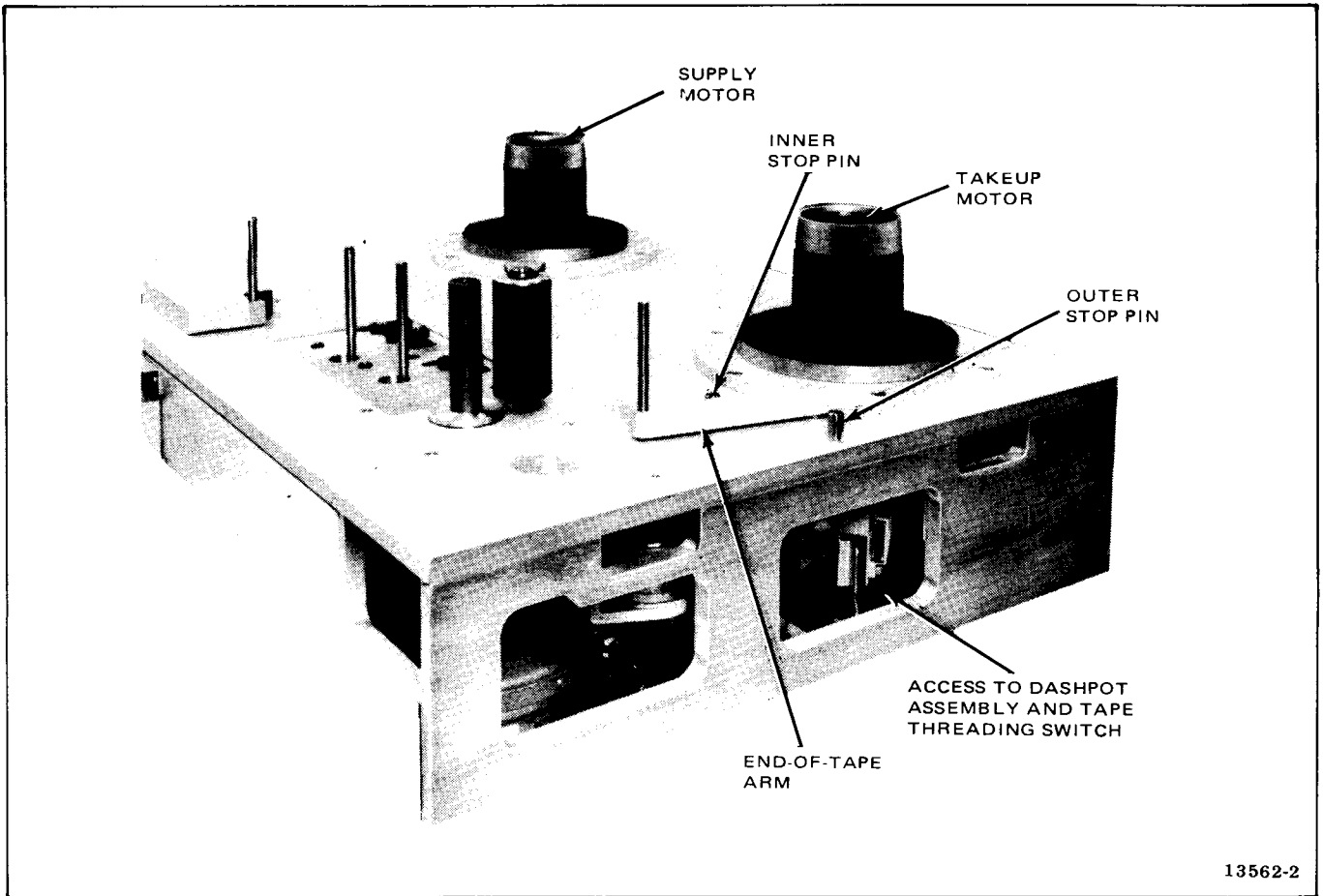

Figure 5-14. Pinch Roller Adjustment



13562-2

Figure 5-15. End-of-Tape Arm

3. Adjust the safety switch actuating screw as necessary, such that the safety switch is actuated immediately before the end-of-tape sensor arm touches the inner stop pin (see Figure 5-16).
4. Loosen the dashpot arm adjust bolt and, with the end-of-tape arm resting on the inner stop pin, move the dashpot into the dashpot cylinder until it bottoms.

CAUTION

OVERTIGHTENING THE DASHPOT ARM ADJUST BOLT WILL DAMAGE OR BREAK THE DASHPOT WIRE.

5. Move the dashpot wire such that the dashpot is removed from the dashpot cylinder bottom

approximately 1/16 inch, and tighten the dashpot arm adjust bolt slightly.

6. Move the end-of-tape arm to approximately the normal position as when it is engaged with the threaded tape, and then allow it to return to the end-of-tape position. The return time should be between 1/2 to 1-1/2 seconds. Adjust the cylinder adjust valve (Figure 5-16) as required to achieve the correct time.
7. Move the end-of-tape sensor arm to the latched position (adjacent to the outer stop pin). See Figure 5-15.
8. Observe that the tape threading switch (Figure 5-17) actuates before the magnet latch plate contacts the magnet catch.

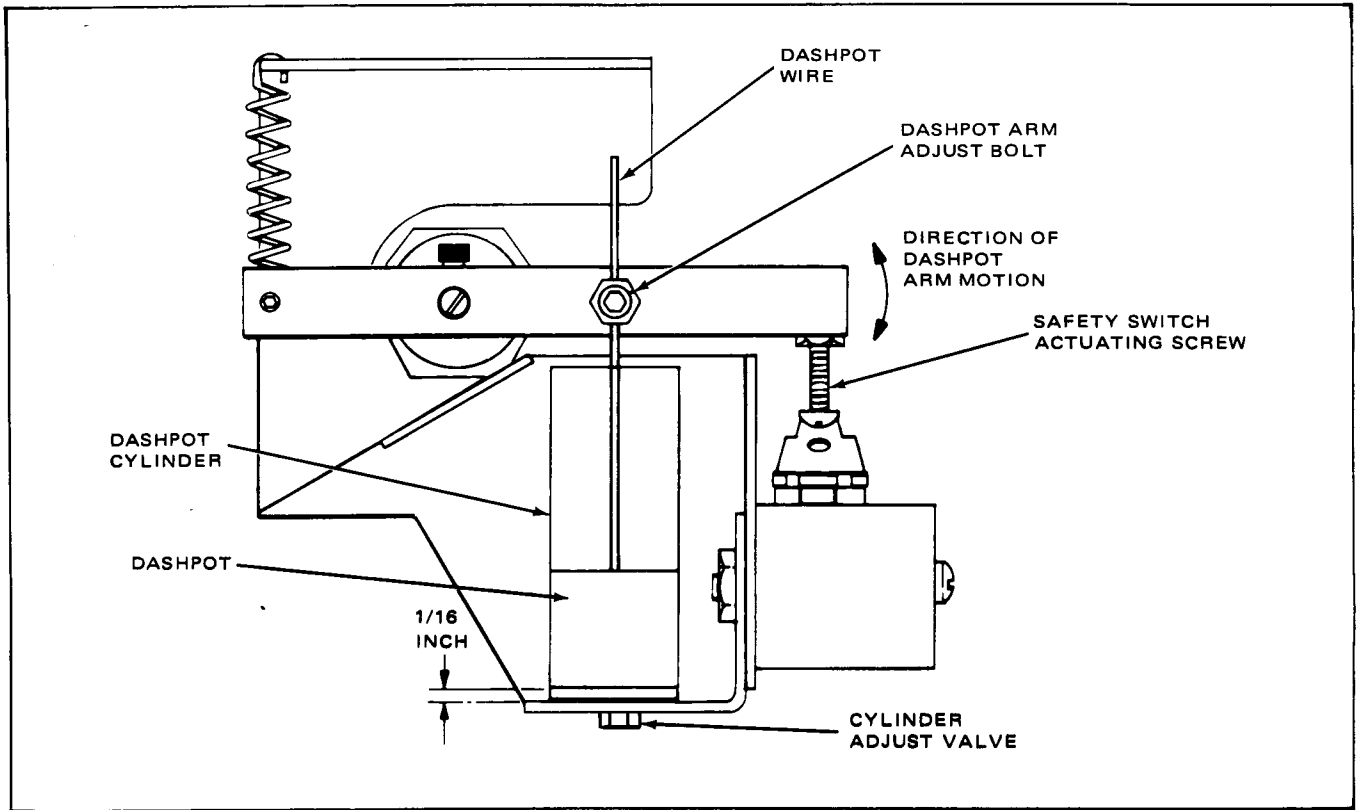

Figure 5-16. Tension Arm Dashpot Assembly

9. Readjust the magnet catch as necessary by loosening the two magnet catch retaining nuts, such that the tape threading switch actuates before the magnet latch plate contacts the magnet catch.

5-38. AUDIO ADJUSTMENTS

Separate audio alignment procedures for operating speed pairs of 7-1/2 - 15 in/s and 15-30 in/s are presented in this section. See Table 5-3 for adjustment controls.

NOTE

The *Reproduce Alignment* procedure must be performed prior to the *Record Alignment* procedure. Also, the BIAS ADJ control adjusted in the *Record Alignment* procedure need only be adjusted for one speed of an operating pair.

These alignment procedures are based on the use of low-noise, high-output tapes (Ampex 406 or equivalent) and reflect the higher saturation levels of these tapes. A new operating level referred to as 'Ampex Mastering Level' is used. This level corresponds to a recorded flux 3 dB higher than the original Ampex Operating Level. (Ampex Operating Level is 185 nWb/m; hence Ampex Mastering Level is 260 nWb/m at 500 Hz.) For optimum performance, it is suggested that the recorder/reproducer be aligned last in the speed most commonly used for recording.

Table 5-3, following, lists the controls on the electronics assemblies that are used for alignment and adjustment of an MM-1200 Recorder/Reproducer audio channel.

5-39. 7-1/2-In/S Reproduce Alignment

Perform the following reproduce alignment procedure.

END-OF-TAPE ARM
TENSION SPRING

DASHPOT
ARM

LATCH PLATE
MOUNTING SCREW

TAPE THREADING
SWITCH

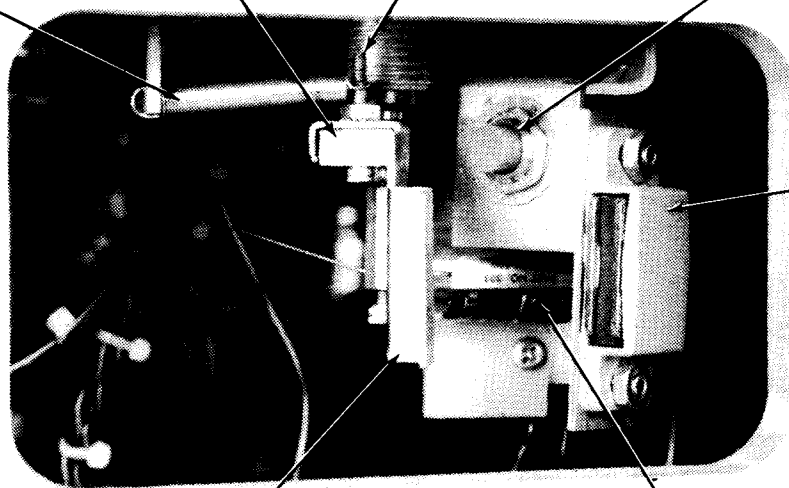

MAGNET
CATCH

MAGNET
LATCH PLATE

DASH POT
ASSEMBLY

13562-3

Figure 5-17. End-of-Tape Arm and Threading Switch Adjustment

1. Prepare the recorder/reproducer for reproduce alignment as follows:
 - a. Demagnetize and clean heads and other components in the tape path. Use Ampex head cleaner on all components except the scrape-flutter idler and pinch roller, which must be cleaned with isopropyl or denatured alcohol.
 - b. Set all RECORD/SAFE switches to SAFE.
 - c. Thread the appropriate alignment tape on the recorder/reproducer (see Table 5-4).
 - d. Set the MASTER MONITOR switch to REPRO.
 - e. Set the STANDBY MONITOR switch to M/MON.
 - f. Set all BIAS/AUDIO switches on the audio switcher modules to AUDIO.
 - g. Select the desired tape speed.
2. Place the recorder/reproducer in the play mode and proceed as follows:
 - a. For 7-1/2-in/s alignment, use the 700-Hz, 10 dB-below-operating-level section of the alignment tape and adjust all REPRO level controls for a mid-scale vu meter indication of -3 vu. (This corresponds to a line output level of +1 dBm.)
 - b. For 15-in/s alignment, use the 700-Hz operating level section (185 nWb/m) of the alignment tape and adjust all REPRO level controls for a mid-scale vu meter indication of -3 vu. (This corresponds to a line output level of +1 dBm.)
 - c. For 15-in/s alignment (only), set the MASTER MONITOR switch to S/SYNC. Use the 700-Hz operating level section

Table 5-3. Electronics Assembly – Alignment Adjustments

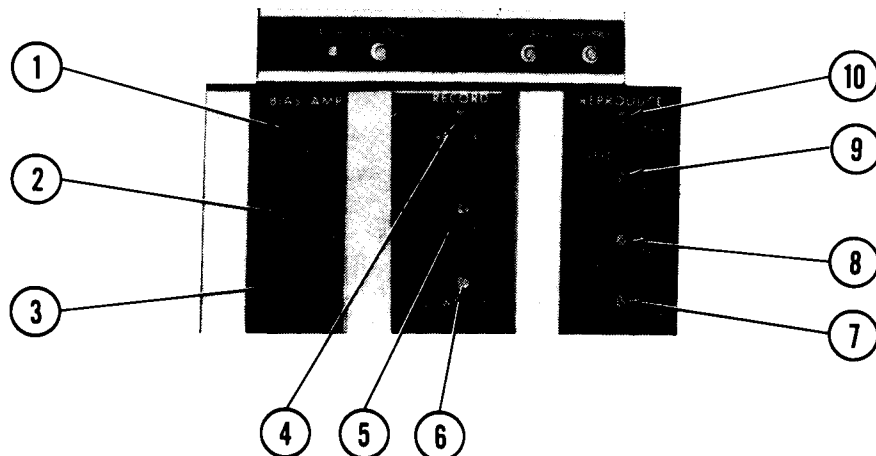

13550-9

| ITEM | CONTROL | USE |
|------|--------------------|--------------------------------------------------------------------------|
| 1 | BIAS CAL | Adjusts vu meter calibration when BIAS/AUDIO switch is in BIAS position. |
| 2 | ERASE PEAK | Adjusts erase level to erase head. |
| 3 | BIAS ADJ | Adjusts record mode bias level for type of tape in use. |
| 4 | REC CAL | Adjusts vu meter calibration to input level. |
| 5 | HI SPEED | Adjusts high speed record equalization. |
| 6 | LOW SPEED | Adjusts low-speed record equalization. |
| 7 | LOW SPEED LOW FREQ | Adjusts low-speed, low frequency reproduce equalization. |
| 8 | LOW SPEED HI FREQ | Adjusts low-speed, high-frequency reproduce equalization. |
| 9 | HI SPEED LOW FREQ | Adjusts high-speed, low-frequency reproduce equalization. |
| 10 | HI SPEED HI FREQ | Adjusts high-speed, high frequency reproduce equalization. |

of the alignment tape, and adjust all S/SYNC level controls for a vu meter indication of -3 vu. Set the MASTER MONITOR switch to REPRO.

3. Adjust the reproduce amplifier HI FREQ equalization control for the speed in use using the 10-kHz section of the alignment tape for a vu meter indication of -3 vu.
4. Monitor the alignment tape tones from 15 kHz through 2.5 kHz, and readjust the reproduce amplifier HI FREQ equalization control as necessary for a minimum deviation from the -3 vu reference established in step 2c.

5. The following reproduce mode low-frequency equalization adjustments, using the alignment tape, are preliminary only. These adjustments must later be finalized in an overall record/reproduce alignment procedure as described in step 5j of the *7-1/2-in/S Record Alignment* procedure, or step 6j of the *15-in/S Record Alignment* procedure, paragraph 5-40.

NOTE

Low-frequency reproduce equalization cannot be adjusted correctly when using a full-track alignment tape because of the fringing effect. For correct adjustment, use an alignment tape corresponding to the track format of the recorder/reproducer being aligned.

Table 5-4. Ampex Alignment Test Tapes

| TYPE | | AMPEX P/N |
|----------------------|------------------------|------------|
| NAB, 1-inch | 7-1/2 in/s, 8-track | 4690007 |
| | 7-1/2 in/s, full-track | 4690049-65 |
| IEC (CCIR), 1-inch | 7-1/2 in/s, 8-track | 4690021 |
| | 7-1/2 in/s, full-track | 4690032 |
| NAB, 2-inch | 7-1/2 in/s, 16-track | 4690022 |
| | 7-1/2 in/s, full-track | 4690025 |
| IEC (CCIR), 2-inch | 7-1/2 in/s, 16-track | 4690034 |
| | 7-1/2 in/s, full-track | 4690036 |
| NAB, 1-inch | 15 in/s, 8-track | 4690006 |
| | 15 in/s, full track | 4690005 |
| IEC(CCIR), 1-inch | 15 in/s, 8-track | 4690020 |
| | 15 in/s, full-track | 4690031 |
| NAB, 2-inch | 15 in/s, 16-track | 4690018 |
| | 15 in/s, full-track | 4690024 |
| IEC (CCIR), 2-inch | 15 in/s, 16-track | 4690033 |
| | 15 in/s, full-track | 4690035 |
| 17.5 μ s, 1-inch | 30 in/s, 8-track | 4690042 |
| | 30 in/s, full-track | 4690048 |
| 17.5 μ s, 2-inch | 30 in/s, 16-track | 4690039 |
| | 30 in/s, full-track | 4690047 |

- a. For 7-1/2-in/s alignment, adjust the reproduce amplifier LOW SPEED LOW FREQ equalizer control for a vu meter indication of -3 vu at 50 Hz.
- b. For 15-in/s alignment, adjust the reproduce amplifier HI SPEED LOW FREQ equalizer control for a vu meter indication of -3 vu at 50 Hz.

6. For 7-1/2-in/s alignment, use the 700-Hz operating level section of the alignment tape and adjust all REPRO level controls for a vu meter indication of -3 vu.
7. For 7-1/2-in/s alignment, set the MASTER MONITOR switch to S/SYNC. Use the 700-Hz operating level section of the alignment tape and adjust all S/SYNC level controls for a vu meter indication of -3 vu. Set the MASTER MONITOR switch to REPRO.
8. Measure reproduce standby noise as follows:
 - a. Connect a band-limiting filter (Figure 5-18) between the line output and an ac vtvm.
 - b. Check that the STANDBY MONITOR switch is at M/MON, and the BIAS/AUDIO switches are at AUDIO.
 - c. Close the head gate.
 - d. Read the reproduce standby noise on the ac vtvm. The indication for either speed should be less than -58 dBm for an 8- or 16-channel system, or less than -54 dBm for 24-channel systems.

5-40. 7-1/2-15 In/S Record Alignment

Do not perform the *7-1/2-15 In/S Record Alignment* procedure unless the reproduce alignment procedure, paragraph 5-39, has been performed first. Proceed as follows:

1. Prepare the recorder/reproducer for record alignment as follows:

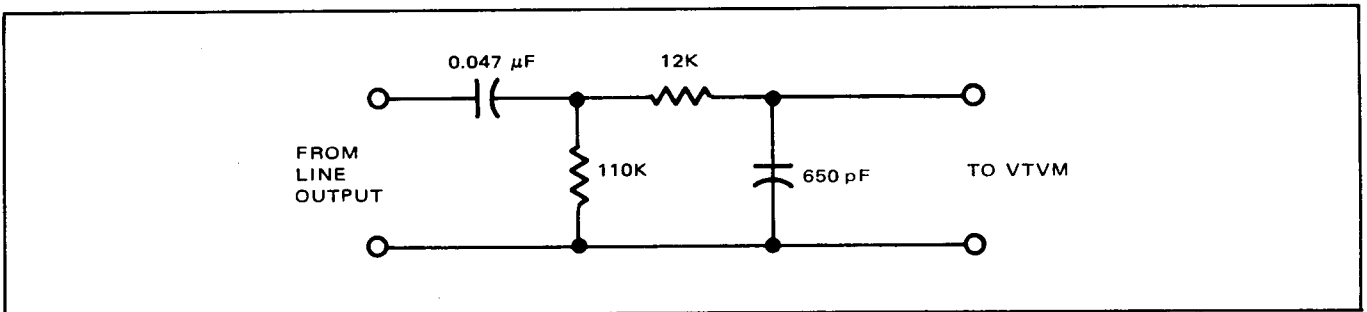

Figure 5-18. 30-Hz to 18-kHz Band Limiting Filter

- a. Thread a reel of bulk-erased tape of the type to be used (Ampex 406, 456, or equivalent) onto the transport.
 - b. Connect a signal generator and an ac vtvm to the line inputs of the recorder/reproducer (see *Cable Connections*, paragraph 2-4, in the installation section of this manual). For the 7-1/2-in/s alignment, set the generator to 5 kHz and +4 dBm. For the 15-in/s alignment, set the generator to 10 kHz and +4 dBm.
 - c. Set the READY/SAFE switches of the channels to be aligned to READY.
 - d. Set the MASTER MONITOR switch to REPRO and the STANDBY MONITOR switch to M/MON.
 - e. Set the BIAS/AUDIO switches on audio switcher modules to BIAS.
2. Place the recorder/reproducer in the record mode. Observe that all channels in the ready mode go into the record mode, and that on-scale indications appear on the vu meters.
 3. For adjustment of the ERASE PEAK control on recorders equipped with the current production version of the 24-channel erase head, part no. 4350329, perform step *a*. For the earlier 24-channel head, part no. 4953257, perform step *b*.

NOTE

The earlier version of the 24-channel erase head may be identified by the protruding pins; whereas in the current production version, the pins are resin-encapsulated.

- a. For 24-channel erase head (4350329) and all 8- and 16-channel recorders, adjust the ERASE PEAK control on each bias amplifier module to provide a maximum indication on its associated vu meter. If necessary, adjust the BIAS CAL controls to obtain on-scale meter indications.

- b. For 24-channel erase head (4953257) turn the ERASE PEAK control fully counterclockwise at the start; then turn it slowly clockwise. The bias level indication will change very slowly at first, but then the vu meter will indicate a sudden drop of 0.5 to 3 dB as the head core comes out of saturation. If this drop is greater than 1.5 dB, turn the ERASE PEAK control slowly counterclockwise so that the indication increases to 1.0 to 1.5 dB down from the level reached just before the sudden drop occurred. Conversely, if the drop is less than 0.5 dB, continue turning the ERASE PEAK control clockwise until the indication decreases to 1.0 to 1.5 dB down from where the sudden drop occurred.

4. Reset the BIAS/AUDIO switches on audio switcher modules to AUDIO, and adjust the RECORD level controls for a mid-scale indication on the vu meters.

5. For 7-1/2-in/s record alignment, proceed as follows:

- a. Adjust the BIAS ADJ control on each BIAS AMP module for a maximum output amplitude of the 5.0-kHz signal. Continue clockwise adjustment of the BIAS ADJ control until the output indication decreases exactly 1.5 dB (406 tape) or 2.5 dB (456 tape).

NOTE

The BIAS ADJ control need be adjusted only for one speed of an operating speed pair.

- b. Set the BIAS/AUDIO switch on the audio switcher modules to BIAS.
- c. Adjust the BIAS CAL control on each BIAS AMP module for an indication of 0 vu on its associated vu meter.
- d. Set the BIAS/AUDIO switches on the audio switcher modules to AUDIO.
- e. Set the generator for 500-Hz and -6 dBm.

f. While recording (MASTER MONITOR switch in REPRO), adjust the REPRO control on the audio switcher modules for a vu meter indication of -3 vu.

NOTE

This is a convenient, temporary setting for making the record level adjustment only. The normal reproduce level will be reset at steps l and m.

g. Set the generator to 12 kHz and -6 dBm.

h. Adjust the record amplifier LOW SPEED equalizer control for a vu meter indication of -3 vu.

i. Set the generator to 50 Hz and -6 dBm.

j. Adjust the reproduce amplifier LOW SPEED FREQ equalizer control to achieve a minimum deviation from -3 vu for frequencies between 40 Hz and 100 Hz.

k. Sweep the generator from 40 Hz to 15 kHz while maintaining a constant -6 dBm generator level. The vu meter should remain within ± 2 vu of the -3 vu point.

l. Remove the recording tape, thread the alignment tape, and set up the recorder/reproducer in the play mode.

m. Using the 700-Hz operating level (last section) of the alignment tape, adjust the REPRO level controls on the audio switcher modules for a vu meter indication of -3 vu. The -3 vu level corresponds to a line output of $+1$ dBm.

n. Replace the alignment tape with the recording tape and set the signal generator for a 1 kHz, $+4$ dBm input.

o. Set the RECORD level control on the audio switcher modules for a vu meter indication of 0 vu.

p. Set the MASTER MONITOR switch to SINGLE.

q. Set the individual INPUT/REPRO/S/SYNC switches to INPUT.

r. Adjust the REC CAL control on each record amplifier for a vu meter indication of 0 vu.

6. For the 15-in/s record alignment, proceed as follows:

a. Adjust the BIAS ADJ on each bias amp module for maximum output of the 10-kHz signal. Continue clockwise adjustment of the BIAS ADJ control until the output indication decreases exactly 1.5 dB (406 tape) or 2.5 dB (456 tape).

NOTE

The BIAS ADJ control need be adjusted only for one speed of an operating speed pair.

Do not perform steps *b*, *c*, and *d* below if steps *5b*, *c*, and *d* of the preceding *7-1/2 In/S Record Alignment* procedure were accomplished.

b. Set the BIAS/AUDIO switches on the audio switcher modules to BIAS.

c. Adjust the BIAS CAL control on each bias amp module for an indication of 0 vu.

d. Set the BIAS/AUDIO switches on the audio switcher modules to AUDIO.

e. Set the generator to 1 kHz and $+4$ dBm.

f. While recording (MASTER MONITOR switch in REPRO), adjust the RECORD level controls on the audio switcher modules for a vu meter indication of 0 vu.

g. Set the generator to 15 kHz and $+4$ dBm.

h. Adjust the record amplifier HI SPEED equalizer control for a vu meter indication of 0 vu.

i. Set the generator to 50 Hz and $+4$ dBm.

- j. Adjust the reproduce amplifier HI SPEED LOW FREQ equalizer control to achieve a minimum deviation from 0 vu for frequencies between 30 Hz and 100 Hz.
 - k. Sweep the generator from 30 Hz to 15 kHz while maintaining a constant +4 dBm output level. The vu meter should remain within ± 2 vu of the 0-vu point.
 - l. Set the generator to 1 kHz and +4 dBm.
 - m. Set the RECORD level controls on the audio switcher modules for a vu meter indication of 0 vu.
 - n. Set the MASTER MONITOR switch to SINGLE.
 - o. Set the individual INPUT/REPRO/S/SYNC switches to INPUT.
 - p. Adjust the REC CAL control on each record amplifier for a vu meter indication of 0 vu.
7. Perform the bias trap adjustment as follows:
- a. Remove tape from recorder/reproducer and set the end-of-tape arm to threading position.
 - b. Set the channel INPUT/REPRO/S/SYNC switch to S/SYNC of the channel to be adjusted.
 - c. Set the MASTER MONITOR switch to SINGLE.
 - d. Set the READY/SAFE switches of channels adjacent to the channel to be adjusted to READY.
 - e. Set the READY/SAFE switch to the channel to be adjusted to SAFE.
 - f. With power off, remove the RECORD amplifier (channel selected for adjustment) from its connector and set it aside.
 - g. Connect an ac vtm to the channel line output connector. Refer to the *Cable Connection* information, paragraph 2-4.
 - h. Apply power to the recorder/reproducer and initiate the record mode.
 - i. Adjust the bias trap inductor, located between the reproduce amplifier and the record amplifier connectors on the motherboard for minimum indication on the ac vtm, using the appropriate tuning tool.
 - j. With the power off, reinstall the record amplifier.

5-41. 15-30 In/S Reproduce Alignment

Perform the following alignment procedure.

1. Prepare the recorder/reproducer for alignment as follows:
 - a. Demagnetize and clean heads and other components in the tape path. Use Ampex head cleaner on all components except the scrape-flutter idler and pinch roller, which must be cleaned with isopropyl or denatured alcohol.
 - b. Set all READY/SAFE switches on the control box assembly to SAFE.
 - c. Thread the appropriate alignment tape on the transport (see Table 5-4).
 - d. Set the MASTER MONITOR switch to REPRO.
 - e. Set the STANDBY MONITOR switch to M/MON.
 - f. Set all BIAS/AUDIO switches on the audio switcher modules to AUDIO.
 - g. Select the desired tape speed.
2. Place the recorder/reproducer in the play mode and proceed as follows:
 - a. Use the 700-Hz operating level section of the alignment tape and adjust all REPRO level controls for a vu meter indication of -3 vu. (This corresponds to a line output of +1 dBm.)

- b. Set the MASTER MONITOR switch to S/SYNC. Use the 700-Hz operating level section of the alignment tape and adjust all S/SYNC level controls for a vu meter indication of -3 vu. Set the MASTER MONITOR switch to REPRO.
3. Adjust the reproduce amplifier HI FREQ equalization control for the speed in use on the 10-kHz section of the alignment tape for a vu meter indication of -3 vu.
4. Monitor the alignment tape tones from 15 kHz through 2.5 kHz and readjust the reproduce amplifier HI FREQ equalization control as necessary for a minimum deviation from the -3 vu reference established previously in step 3.
5. The following reproduce mode low-frequency equalization adjustments, using an alignment tape, are preliminary only. These adjustments must later be finalized in an overall record/reproduce alignment procedure as described in step 5j or the *15 In/S Record Alignment* procedure or step 6j of the *30 In/S Record Alignment* procedure, paragraph 5-42.
 - a. Connect a band-limiting filter (Figure 5-18) between the line output and an ac vtm.
 - b. Check that the STANDBY MONITOR switch is at M/MON and the BIAS/AUDIO switches on audio switcher modules are at AUDIO.
 - c. Close the head gate.
 - d. Read reproduce standby noise on the ac vtm. The indication for either speed should be less than -58 dBm for 8- or 16-channel systems, and less than -54 dBm for 24-channel systems.

5-42. 15-30 In/S Record Alignment

Do not perform the *15-30 In/S Record Alignment* procedures unless the reproduce alignment procedure has been performed first. Proceed as follows:

1. Prepare the recorder/reproducer for record alignment as follows:
 - a. Thread a reel of bulk-erased tape of the type to be used (Ampex 406, 456, or equivalent) onto the transport.
 - b. Connect a signal generator and an ac vtm to the line inputs of the recorder/reproducer (see *Cable Connections*, paragraph 2-4 in the Installation section of this manual). For the 15-in/s alignment, set the generator to 10 kHz and +4 dBm. For the 30-in/s alignment, set the generator to 20 kHz and +4 dBm.
 - c. Set the READY/SAFE switches of the channels to be aligned to READY.
 - d. Set the MASTER MONITOR switch to REPRO and the STANDBY MONITOR switch to M/MON.
 - e. Set the BIAS/AUDIO switches on the audio switcher modules to BIAS.
2. Place the recorder/reproducer in the record mode. Observe that all channels in the ready mode go into the record mode, and that on-scale indications appear on the vu meters.

NOTE

Low-frequency equalization cannot be adjusted correctly when using a full-track alignment tape because of the fringing effect. For correct adjustment, use an alignment tape corresponding to the track format of the recorder/reproducer being aligned.

- a. For 15-in/s alignment, adjust the reproduce amplifier LOW SPEED LOW FREQ equalizer control for a vu meter indication of -3 vu at 50 Hz.
 - b. For 30-in/s alignment, adjust the reproduce amplifier HIGH SPEED LOW FREQ equalizer control for a vu meter indication of -4 vu at 30 Hz.
6. Measure the reproduce standby noise as follows:

3. For adjustment of the ERASE PEAK control on recorders equipped with the current production version of the 24-channel erase head, part no. 4350329, perform step *a*. For the earlier 24-channel head, part no. 4953257, perform step *b*.

NOTE

The earlier version of the 24-channel erase head may be identified by the protruding pins at the rear of the erase head, whereas in the current production version, the pins are resin-encapsulated.

- a. For 24-channel erase head (4350329) and all 8- and 16-channel recorders, adjust the ERASE PEAK control on each bias amplifier module to provide a maximum indication on its associated vu meter. If necessary, adjust the BIAS CAL controls to obtain on-scale meter indications.
 - b. For 24-channel erase head (4953257) turn the ERASE PEAK control fully counterclockwise at the start; then turn it slowly clockwise. The bias level indication will change very slowly at first, but then the vu meter will indicate a sudden drop of 0.5 to 3 dB as the head core comes out of saturation. If this drop is greater than 1.5 dB, turn the ERASE PEAK control slowly counterclockwise so that the indication increases to 1.0 to 1.5 dB down from the level reached just before the sudden drop occurred. Conversely, if the drop is less than 0.5 dB, continue turning the ERASE PEAK control clockwise until the indication decreases to 1.0 to 1.5 dB down from where the sudden drop occurred.
4. Reset the BIAS/AUDIO switches on the audio switcher modules to AUDIO, and adjust the RECORD level controls for a mid-scale indication on the vu meters.
 5. For 15-in/s record alignment, proceed as follows:
 - a. Adjust the BIAS ADJ control on each bias amp module for a maximum output amplitude of the 10.0-kHz signal. Continue

clockwise adjustment of the BIAS ADJ control until the output indication decreases exactly 1.5 dB (406 tape) or 2.5 dB (456 tape).

NOTE

The BIAS ADJ control need be adjusted only for one speed of an operating speed pair.

- b. Set the BIAS/AUDIO switches on the audio switcher modules to BIAS.
- c. Adjust the BIAS CAL control on each bias amp module for an indication of 0 vu on its associated vu meter.
- d. Set the BIAS/AUDIO switches on the audio switcher modules to AUDIO.
- e. Set the generator for 1 kHz and +4 dBm.
- f. Adjust the RECORD controls on the audio switcher modules for a vu meter indication of 0 vu.
- g. Set the generator to 15 kHz and +4 dBm.
- h. Adjust the record amplifier LOW SPEED equalizer control for a vu meter indication of 0 vu.
- i. Set the generator to 50 Hz and +4 dBm.
- j. Adjust the reproduce amplifier LOW SPEED LOW FREQ equalizer control to achieve a minimum deviation from 0 vu for frequencies between 30 Hz and 100 Hz.
- k. Sweep the generator from 30 Hz to 15 kHz while maintaining a constant +4 dBm output level. The vu meter should remain within ± 2 vu of the 0-vu point.
- l. Set the generator to 1 kHz and +4 dBm.
- m. Set the RECORD level controls on the audio switcher modules for a vu meter indication of 0 vu.
- n. Set the MASTER MONITOR switch to SINGLE.

- o. Set the individual INPUT/REPRO/S/SYNC switches to INPUT.
 - p. Adjust the REC CAL control on each record amplifier for a vu meter indication of 0 vu.
6. For the 30-in/s record alignment, proceed as follows:
- a. Adjust the BIAS ADJ on each bias amp module for maximum output of the 20-kHz signal. Continue clockwise adjustment of the BIAS ADJ control until the output indication decreases exactly 1.5 dB (406 tape) or 2.5 dB (456 tape).

NOTE

The BIAS ADJ control need be adjusted only for one speed of an operating speed pair.

Do not perform steps *b*, *c*, and *d* following if steps *5b*, *c*, and *d* of the preceding 15 In/S Record Alignment procedure were accomplished.

- b. Set the BIAS/AUDIO switches on the audio switcher modules to BIAS.
- c. Adjust the BIAS CAL control on each bias amp module for an indication of 0 vu.
- d. Set the BIAS/AUDIO switches on the audio switcher modules to AUDIO.
- e. Set the generator to 1 kHz and +4 dBm.
- f. Adjust the RECORD level control for a vu meter indication of 0 vu.
- g. Set the generator to 15 kHz and +4 dBm.
- h. Adjust the record amplifier HI SPEED equalizer control for a vu meter indication of 0 vu.
- i. Set the generator to 50 Hz and +4 dBm.
- j. Adjust the reproduce amplifier HI SPEED LOW FREQ equalizer control to achieve

a minimum deviation from 0 vu for frequencies between 50 Hz and 100 Hz.

- k. Sweep the generator from 50 Hz to 18 kHz while maintaining a constant +4 dBm output level. The vu meter should remain within ± 2 vu of the 0-vu point.
 - l. Set the generator to 1 kHz and +4 dBm.
 - m. Set the RECORD level controls on the audio switcher modules for a vu meter indication of 0 vu.
 - n. Set the MASTER MONITOR switch to SINGLE.
 - o. Set the individual INPUT/REPRO/S/SYNC switches to INPUT.
 - p. Adjust the REC CAL control on each record amplifier for a vu meter indication of 0 vu.
7. Perform the bias trap adjustment as follows:
- a. Remove tape from recorder/reproducer and set the end-of-tape arm to threading position.
 - b. Set the channel INPUT/REPRO/S/SYNC switch to S/SYNC of the channel to be adjusted.
 - c. Set the MASTER MONITOR switch to SINGLE.
 - d. Set the READY/SAFE switches of channels adjacent to the channel to be adjusted to READY.
 - e. Set the READY/SAFE switch of the channel to be adjusted to SAFE.
 - f. With power off, remove the record amplifier (channel selected for adjustment) from its connector and set it aside.
 - g. Connect an ac vtvm to the channel line output connector. Refer to the *Cable Connection* information, paragraph 2-4.

- h. Apply power to the recorder/reproducer and initiate the record mode.
- i. Adjust the bias trap inductor, located between the reproduce amplifier and the record amplifier connectors on the motherboard, for minimum indication on the ac vtvm, using the appropriate tuning tool.
- j. With power off, reinstall the record amplifier.

5-43. Distortion Measurement

Perform the following procedure to measure the system distortion.

NOTE

It is assumed that the heads and tape path have been demagnetized and correct record and reproduce alignments have been performed prior to performing the distortion measurements.

1. Set up the system as follows:
 - a. Thread a reel of demagnetized tape of the type to be used (Ampex 406 or equivalent) onto the transport.
 - b. Set all READY/SAFE switches to READY.
 - c. Set the MASTER MONITOR switch to REPRO and the STANDBY MONITOR switch to M/MON.
 - d. Connect a signal generator (Table 5-1) to the line inputs (see *Cable Connections* information in the Installation section, paragraph 2-4). Adjust the generator frequency to 1 kHz and +4 dBm.
2. Place the recorder/reproducer in the record mode. Ensure that all vu meters indicate 0 vu. Adjust the RECORD level controls as necessary.
3. Connect a wave analyzer (Table 5-1) to the line outputs and normalize its full scale reading at 1 kHz. Measure the second harmonic

content; this should not exceed 0.3% or -50 dB with respect to the fundamental. Similarly measure the third harmonic content; this should not exceed 1% or -40 dB with respect to the fundamental. Repeat this procedure for each channel.

4. If the measurements taken in step 3 are not within the limits indicated, refer to the *Troubleshooting* section, paragraph 5-46, for a possible cause.

5-44. Noise and Erasure Depth

Perform the following procedure to measure the system noise and erasure depth.

1. Prepare the system as follows:
 - a. Thread a reel of bulk erased tape of the type to be used (Ampex 406, 456, or equivalent) onto the transport.
 - b. Set all READY/SAFE switches to READY.
 - c. Set the MASTER MONITOR switch to REPRO, the STANDBY MONITOR switch to M/MON, and the BIAS/AUDIO switches to AUDIO.
 - d. Connect a signal generator (Table 5-1) to the line inputs (see *Cable Connections* information, paragraph 2-4). Adjust the generator to 1 kHz and +4 dBm.
2. Place the recorder/reproducer into the record mode and adjust the RECORD level controls for an indication of 0 vu on the vu meters. Increase the generator output level to +10 dBm and record three minutes of this signal.
3. Rewind the tape to the beginning of the recorded section and remove the signal generator input signal. Terminate the recorder/reproducer signal inputs with 600 ohms or a short circuit, and connect an ac vtvm (Table 5-1) through a band limiting filter (Figure 5-18).
4. Place the recorder/reproducer into the record mode again, and measure the residual noise

indicated on the ac vtvm for each channel. For 8- and 16-track systems, the indication should be not less than -53 dBm and for 24-track systems, not less than -48 dBm.

NOTE

If it is desired to obtain ASA 'A' weighted readings, the ASA 'A' weighted filter shown in Figure 5-19 may be used in place of the band limiting filter shown in Figure 5-18. If the ASA 'A' weighted filter is used, it is necessary to correct for the insertion loss of that filter. This may be accomplished by adding +4 dBm to the ac vtvm indication when making the measurements.

The residual noise figures obtained in step 4 preceding, are absolute noise levels. When referred to the peak signal level of +10 dBm, the signal-to-noise ratio is obtained (i.e., meter indicates -55 dBm using the band limiting or ASA 'A' weighted filter, therefore, the signal-to-noise ratio is 65 dB unweighted).

5-45. Bias Amp Module Alignment

NOTE

This adjustment should normally be required only if a bias amp module is used in a channel in which it was not previously used, or if failure of the amplifier requires component replacement.

Perform the following bias amp module alignment.

1. Prepare the recorder/reproducer as follows:
 - a. With power off, place the bias amp module of the channel to be aligned on an extender board, part no. 4020153-04.
 - b. Set the bias balance potentiometer R92 to mid-position.
 - c. Set the BIAS/AUDIO switch on associated audio switcher module to BIAS.
 - d. Set the channel READY/SAFE switch to READY.
 - e. Set the MASTER MONITOR switch to REPRO.
 - f. Thread a reel of blank tape of the type to be used (Ampex 406, 456, or equivalent) onto the transport.
2. Place the recorder/reproducer into the record mode and proceed as follows:
 - a. Adjust the BIAS CAL control on the bias amp module to obtain a 2/3 scale indication on the vu meter.
 - b. Adjust the core of T3 (nearest to the connector) to achieve maximum indication on the vu meter.

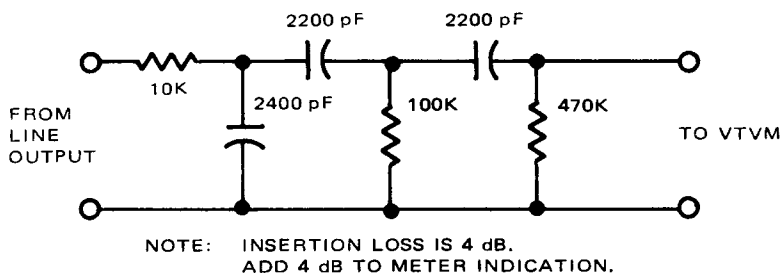

Figure 5-19. ASA 'A' Weighted Filter

- c. Repeat step 2a, if necessary, and then adjust the core of T4 (farthest from the connector) to achieve maximum indication on the vu meter.

NOTE

In steps 2b and 2c, two peaks will be observed; use either of these peaks.

3. Adjust the ERASE PEAK control for maximum indication on the vu meter and proceed as follows:
 - a. Adjust the core of T3 such that the vu meter indicates at the center of the dip between the two peaks observed in step 2a.
 - b. Check that the ERASE PEAK control is still adjusted to provide maximum output.
4. Perform the appropriate *Record Alignment* procedures, paragraph 5-40 for 7-1/2-15 in/s systems or paragraph 5-42 for 15-30-in/s systems.
5. Adjust R92 as follows:
 - a. Connect an ac vtm through an ASA 'A' weighted filter (Figure 5-19) to the line output connector.
 - b. Adjust R92 for a minimum indication on the ac vtm. If a noise null cannot be found within the range of R92, refer to the *Troubleshooting* section of this manual, paragraph 5-46.
6. If desired, the second harmonic distortion may be rechecked as described in the *Distortion Measurement* procedure, paragraph 5-43.

5-46. TROUBLESHOOTING

Use standard troubleshooting techniques to isolate faults to a specific stage or component. The dc, signal, and bias voltages are given at many points on the associated schematic diagrams as an aid in locating malfunctions. Schematic diagrams for the recorder/reproducer circuits are located in the *Parts Lists and Schematics* section of this manual.

5-47. Possible Corrective Actions

Any of the following corrective actions may be required to bring the equipment within specifications.

1. Clean the heads.
2. Demagnetize the heads.
3. Adjust the signal generator for flat output over the frequency range in use.
4. Adjust the bias level.
5. Adjust reproduce equalization.
6. Adjust record equalization.
7. Adjust tape tension.

Adjustment and alignment procedures that may be needed during maintenance or troubleshooting were presented earlier in this section of the manual.

5-48. Causes of Tape Speed Error

Some causes of tape speed error are given below.

1. Tape slippage at capstan. This may be caused by either of the following:
 - a. Slick or oily capstan or capstan pinch roller.
 - b. Insufficient pinch roller pressure.
2. Pinch roller solenoid not bottoming.
3. Incorrect tape tensions.
4. Dragging reel motor brakes.

5-49. Causes of Noise

Some causes of noise (low signal-to-noise ratio) are listed below.

1. Incorrect setting of operating levels.
2. Head gate open during noise check, causing hum.

3. External fields from nearby motor or transformers being introduced into heads, cables or electronics, causing hum.
4. Heads need demagnetizing, causing popping-type noise.
5. Erase peaking adjustment not at peak, causing unsymmetrical bias and popping-type noise.
6. Reproduce equalization not correct, causing excessive high frequency noise.

5-50. Causes of Distortion

Some causes of distortion, detected during performance tests, are given in the following paragraphs.

Second Harmonic Distortion:

1. Magnetized heads.
2. Erase peaking adjustment or erase transformers not peaked, causing unsymmetrical bias and high distortion.
3. Malfunction in the bias oscillator such that the bias signal output becomes unsymmetrical.
4. Malfunction of the record or reproduce amplifiers.

Third Harmonic Distortion:

1. Reproduce calibration control incorrectly adjusted such that operating levels are not correct.
2. A conventional tape used at 260 nWb/m operating level will cause more than normal distortion and a high output tape used at 185 nWb/m will produce less than normal distortion.
3. Bias setting incorrect.
4. Malfunction of record or reproduce amplifiers.

5-51. Causes of Flutter

Excessive flutter can be caused by any component that affects the tape motion, but is usually caused by the following.

1. Oxide or dirt on components in the tape path.
2. Servo gain incorrectly adjusted, loose or misadjusted rotor, loose or misadjusted tach probe, or malfunction of servo electronics.
3. Excessive or erratic holdback tension, dragging brakes, or bent shaft on supply motor.
4. Defective capstan pinch roller, defective bearing, or incorrect pressure adjustment of pinch roller.
5. Excessive wear of head assembly.
6. Tape scrape, warped or damaged reels.

5-52. Flutter Troubleshooting Hints. As an aid in troubleshooting, a flutter bridge (Table 5-1) can be used to isolate flutter to specific frequencies. Connect the flutter bridge to the audio output and, using the appropriate test tape, compare the rotational rates in Table 5-5 with the flutter meter indication to aid in determining the cause of the trouble.

Table 5-5. Rotational Rates (Revolutions/Second)

| COMPONENT | TAPE SPEED | | |
|----------------------|------------|---------|---------|
| | 7-1/2 in/s | 15 in/s | 30 in/s |
| Servo Motor | 3.13 | 6.26 | 12.52 |
| Pinch Roller | 1.70 | 3.40 | 6.80 |
| Scrape-Flutter Idler | 6.38 | 12.77 | 25.54 |

5-53. Transport Control

Problems in the transport control system can occur in the transport control PWA, the motor drive amplifier (MDA), the associated power source, the servo system, or the control box. Table 5-6 provides a list of failure symptoms and possible causes which will lead to the defective assembly. Perform the indicated checkout and/or adjustment

procedure presented in the *Maintenance Adjustment* section of this manual, paragraph 5-25. If this does not correct the trouble, then troubleshoot the defective assembly using standard troubleshooting techniques.

Table 5-6. Troubleshooting Hints – Transport System (Continued)

Table 5-6. Troubleshooting Hints – Transport System

| SYMPTOM | POSSIBLE CAUSE |
|---------------------------------------------------------------------------------------------------------------|------------------------------------------------------------------------------------------------------------------------------------------------------|
| No tape movement in play mode | Pinch roller inoperative Supply tension too high Capstan motor inoperative |
| Slow tape movement in play mode | Pinch roller pressure misadjusted Pinch roller solenoid not bottoming Rewind tension too high Capstan servo system misadjusted or defective |
| Tape pulled through the capstan in play mode | Takeup tension too high Tension sensor misadjusted |
| Tape spillage | Supply and/or takeup tension misadjusted Tension sensor misadjusted |
| Slow tape movement in fast forward mode | Supply tension misadjusted Takeup MDA misadjusted Tension sensor misadjusted |
| No tape movement in fast forward mode | Defective takeup MDA Defective takeup reel motor Defective transport control circuits |
| Slow tape movement in rewind mode | Supply tension misadjusted Tension sensor misadjusted Supply MDA misadjusted |
| No tape movement in rewind mode | Defective supply MDA Defective supply reel motor |
| No tape lifter operation | Defective tape lifter circuitry in transport control PWA Defective lifter solenoid |
| Individual STOP, FAST FWD, REWIND, PLAY, LIFT DEFEAT, or RECORD push-buttons do not illuminate when depressed | Defective incandescent bulb Defective circuitry in transport control PWA or control box |

| SYMPTOM | POSSIBLE CAUSE |
|-------------------------------------------------------------------------|-------------------------------------------------------------------------------------------------------------------------------------------------------------------------------|
| End-of-tape sensor inoperative | Defective safety switch Defective transport control circuitry Misadjusted linkage in sensor arm |
| Electronic timer inoperative | Defective +5-Vdc regulator in power supply Defective power supply |
| Timer does not reset to zero when RESET DISPLAY pushbutton is depressed | Defective RESET DISPLAY switch Defective timer circuitry |
| Search mode not entered when SEARCH pushbutton is depressed | Defective SEARCH switch Defective search-to-cue circuitry Defective fast forward and/or rewind circuitry in transport control PWA |
| Search mode entered but cue point not achieved | Defective CUE switch Defective search-to-cue circuitry |
| Noisy capstan motor | Defective bearings or brushes |
| Excessive flutter | Defective capstan motor bearings or brushes Flutter idler(s) misadjusted or defective (also see <i>Causes of Flutter</i> , paragraph 5-51) |
| Inoperative capstan motor | Defective capstan servo circuitry Defective capstan servo motor Dummy plug not in VARIABLE SPEED socket |
| Incorrect tape speed | Defective SPEED switch or associated circuitry in transport control PWA or control box Speed strapping on capstan servo PWA incorrect Defective capstan servo circuitry |

5-54. Audio Switching

Problems in the audio switching system can occur in the audio switcher PWA or the control box. Table 5-7 provides a list of failure symptoms and possible causes which will help isolate the defective assembly. Perform standard troubleshooting techniques to determine defective components.

Table 5-7. Troubleshooting Hints – Audio Switching System

| SYMPTOM | POSSIBLE CAUSE |
|-------------------------------------------------------------------------------------|-------------------------------------------------------------------------------------------------------------------------------------------------------------------------------------------------------------------------------------------------------------------------------------------------------------------------------------------------------------------------------------|
| Individual channel fails to enter record mode when RE-CORD pushbutton is depressed | Individual INPUT/REPRO/S/SYNC switch or associated circuitry defective READY/SAFE switch defective or not set to the READY position |
| Individual channel fails to hold record mode | Relay or associated circuitry in audio switcher PWA defective |
| All channels fail to enter or hold record mode when RE-CORD pushbutton is depressed | MASTER MONITOR switch or associated circuitry in the audio switcher PWA defective +24-Vdc power supply defective |
| Erratic operation of audio switching LEDs | The audio switching overload protection circuit may have been triggered. Try resetting by turning the power off, then on. An overload may be confirmed as follows: Set all individual channel switches to S/SYNC, and the MASTER MONITOR switch to SINGLE or S/SYNC. All INPUT and S/SYNC LEDs will be lighted, but at half intensity, if an audio switching line is overloaded. |

5-55. Audio Signal

Problems in the audio signal system can occur in the reproduce amplifier, the record amplifier, the bias amp module and the audio switcher module.

If a trouble is suspected in any of these units, temporarily substitute a unit from a known operational channel, or substitute the suspect unit into an operational channel to verify operation.

5-56. Reproduce Amplifier. There are two methods of providing an input to troubleshoot the reproduce amplifier as follows:

1. Use of flux loop to introduce a constant flux into the reproduce head, thus introducing a constant current into the reproduce amplifier.
2. Use of a resistor divider in place of the reproduce head to induce a constant voltage into the reproduce amplifier.

Using one of the input devices described, the reproduce amplifier may be examined according to standard troubleshooting techniques.

5-57. Record Amplifier. There are two methods of troubleshooting the record amplifier. These are as follows:

1. Use of a current probe to measure the amount of current in the record head.
2. Measuring the voltage across a resistor substituted for the record head.

Using an audio signal generator (Table 5-1), perform standard troubleshooting techniques to locate defective components.

5-58. Bias Amp Module. If none of the bias amp modules are operational, the bias oscillator in the power supply or the +27-Vdc power supply should be examined. If any channel bias amp module is not operational, troubleshoot the unit while in the record mode so that the input signal for the bias amp module is available from the bias oscillator.

5-59. Power Supply

Problems in the power supply can occur in any of the voltage regulators or the power handling devices. Table 5-8 provides a list of failure symptoms and possible causes which will help isolate the defective assembly or component.

Table 5-8. Troubleshooting Hints – Power Supply

| SYMPTOM | POSSIBLE CAUSE |
|-------------------------------|----------------------------------------------------------------------------------------------------------------------|
| No voltage – fans inoperative | Blown fuse F6 Defective power switch |
| No voltage – fans operate | Defective rectifier bridges Open pass or driver transistors Defective regulator circuits |
| Blown Fuses | |
| F1 | Defective transformer Defective rectifier Defective fan(s) (any one of three) Miswired primary taps |
| F2 | Excessive current in auxiliary ac circuit |
| F3 | Defective pass or driver transistors +39V circuit Defective +39V regulator circuit Output voltage set too high |
| F4 | Defective pass or driver transistors +27V circuit Defective +27V regulator circuit Output voltage set too high |
| F5 | Defective +5V regulator |
| F6 | Defective fan motor or overload in takeup reel motor circuit |
| F7 | Overload in supply reel motor circuit |
| Low output voltage | Defective pass or driver transistors Defective regulator circuit |
| Overcurrent circuit tripped | Excessive current in load circuit Overcurrent adjustment set too low |

5-60. REMOVAL AND REPLACEMENT

This section contains procedures which provide information to facilitate removal and replacement of various components of the MM-1200 Recorder/Reproducer.

5-61. Control Box Assembly

Removal and replacement procedures for the control box assembly contain disassembly instructions, removal and replacement of various components, and reassembly instructions.

5-62. Disassembly. Disassemble the control box assembly as follows:

1. Remove the control box from the recorder/reproducer by lifting it away from its plastic retainers, and disconnect the electrical connector.
2. Remove three 6/32 retaining screws and No. 6 washers that secure the control box assembly case and remove the case (see Figure 5-20).
3. Remove two countersunk 6/32 retaining screws from the connector retaining bracket and move the connector bracket aside (see Figure 5-21).
4. Remove three 6/32 countersunk retaining screws from the case retaining bracket and set the bracket aside (see Figure 5-21).

5-63. Toggle Switch Removal and Replacement. Remove and replace any toggle switch as follows:

1. Remove three 8/32 screws that secure the switch PWA to the LED PWA (see Figure 5-22), and carefully separate the two assemblies, allowing them to hinge apart on the ribbon cables (see Figure 5-23).
2. Using a desoldering tool, remove the solder from the PWA connections of the switch to be removed. (The small indicator logic PWAs may be bent aside to permit access to the switch terminals.)
3. Remove the two 2/56 retaining screws that secure the switch to the mounting bar (see Figure 5-23).
4. Remove the switch.

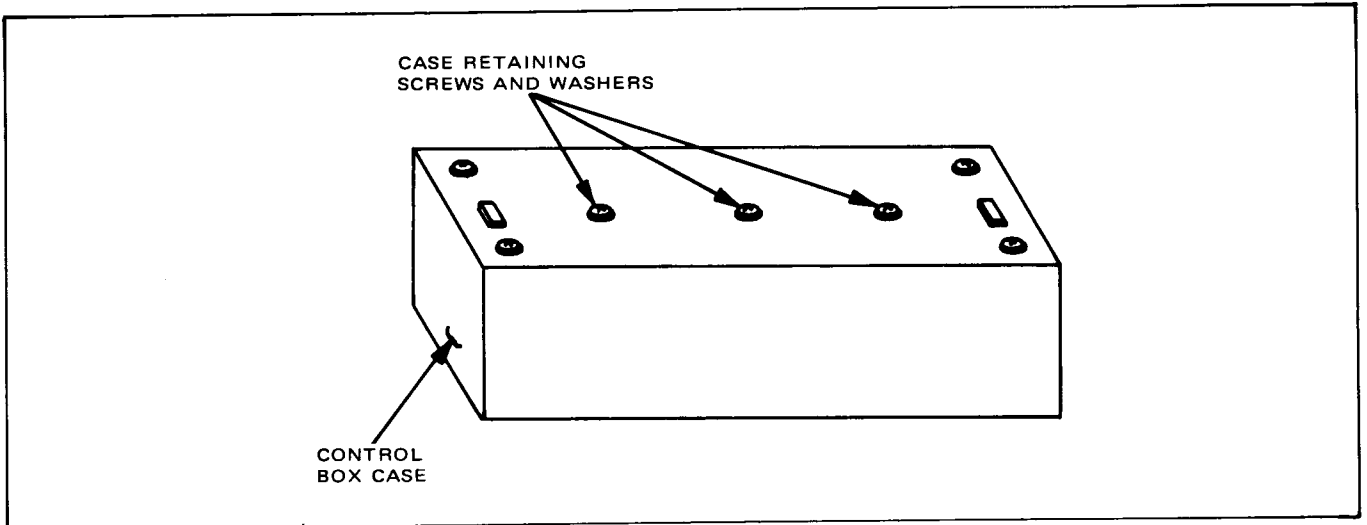

Figure 5-20. Control Box Case Removal

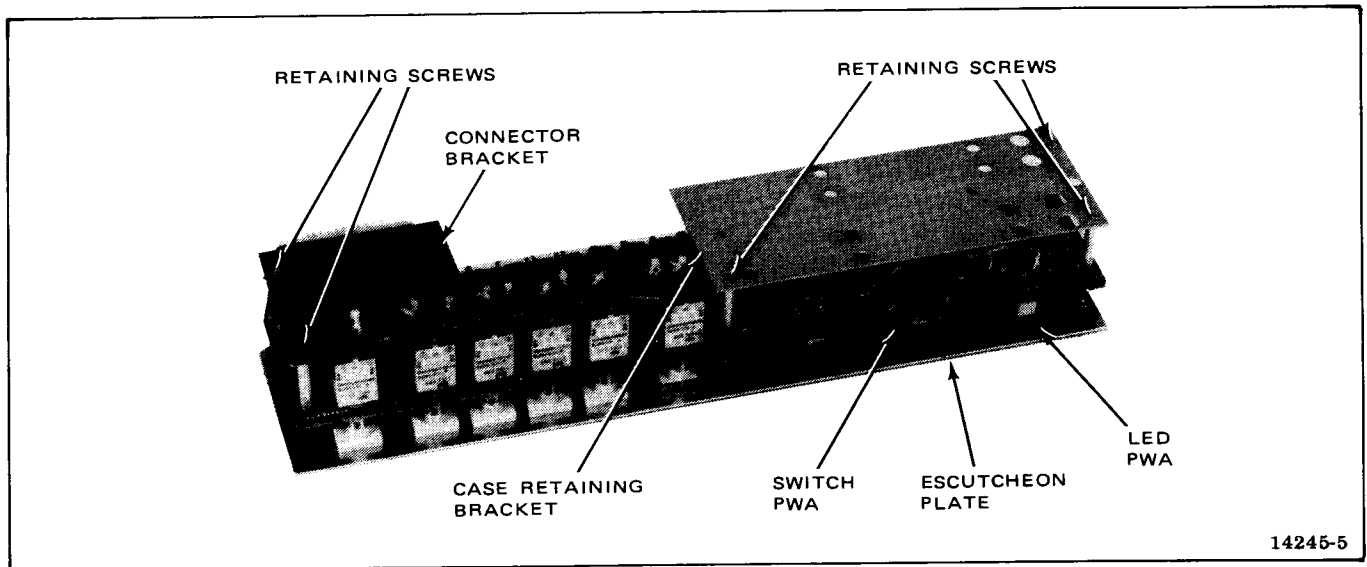
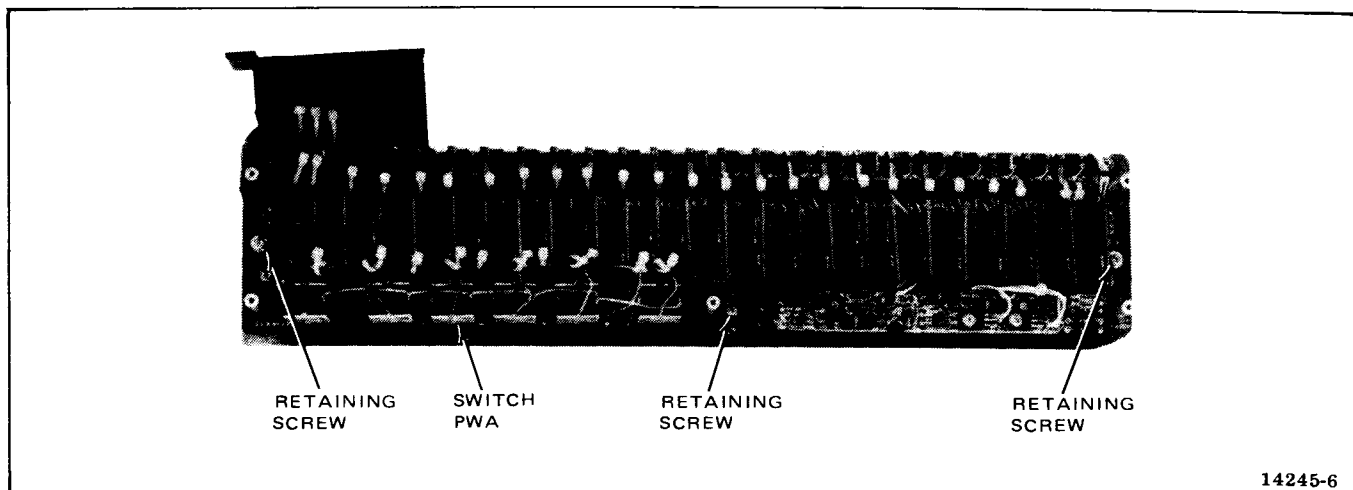

Figure 5-21. Control Box Assembly

5. Ensure that the PWA connection holes are clear, and insert the new switch in the holes vacated by the removed switch.
6. Insert the two 2/56 retaining screws into the switch mounting flange and tighten finger-tight only.
7. Mate the switch PWA to the LED PWA, insert three 8/32 switch PWA retaining screws, align the two units such that all the switch handles move freely, and tighten the three switch PWA retaining screws.
8. Align the newly-installed switch such that the handle moves freely.
9. Solder the switch connections to the switch PWA.



14245-6

Figure 5-22. Switch PWA Disassembly

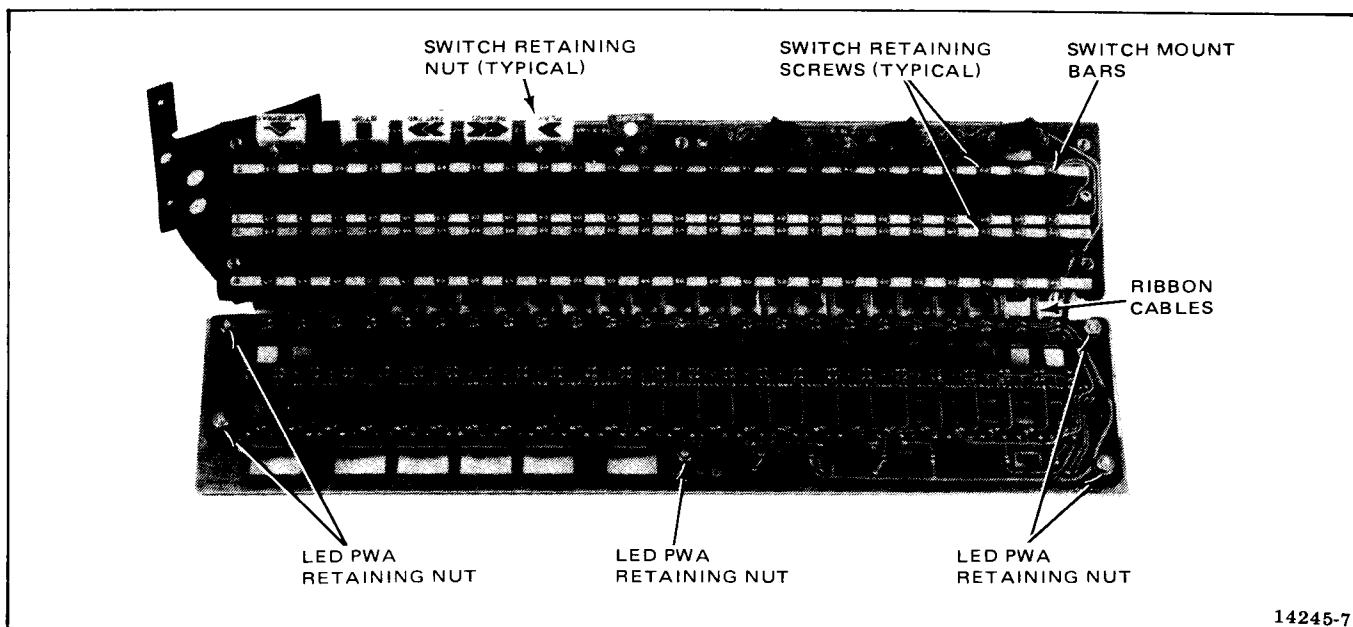

14245-7

Figure 5-23. Switch Replacement

10. Remove the three 8/32 switch PWA retaining screws, remove the switch PWA, and tighten the switch mounting flange retaining screws.
11. Reassemble the switch PWA to the LED PWA as described in step 7 and reinstall the control box case as described in the *Reassembly* instructions, paragraph 5-66.

5-64. Pushbutton Switch Removal and Replacement. Remove and replace any of the control box pushbutton switches as follows:

1. Disassemble the control box as described in steps 1, 2, and 4 of the *Disassembly* procedure, paragraph 5-62.

2. Unsolder four wires from the switch to be removed, and remove the illuminated push-button.
3. Remove the retaining nut from the switch and remove the switch (see Figure 5-23).
4. Install the new switch and tighten the retaining nut finger-tight only.
5. Resolder the four wires to the new switch.
6. Align the new switch such that it moves freely when depressed, and tighten the retaining nut.
7. Reassemble the control box as described in the *Reassembly* instructions, paragraph 5-66.

5-65. LED Removal and Replacement. Remove and replace any of the LEDs or components on the LED PWA as follows:

1. Disassemble the control box as described in steps 1 through 4 of the preceding *Disassembly* procedure, paragraph 5-62.
2. Remove five 6/32 hex nuts and washers from the rear of the LED PWA (see Figure 5-23), and remove the escutcheon plate.
3. Remove and replace LEDs or other components as necessary.

CAUTION

USE A SUITABLE HEATSINK TO PREVENT DAMAGE TO THE LEDS.

4. Mate the escutcheon plate to the LED PWA and reinstall five 6/32 retaining nuts and washers finger-tight only.

NOTE

The following step requires extreme care in order to obtain proper results.

5. Carefully align the escutcheon plate, the LED PWA, and the switch PWA such that all switches move freely and to the limit of their travel; then tighten the five retaining nuts on the LED PWA.

NOTE

It may be necessary to loosen the retaining nuts and screws and repeat step 5 above several times until the desired result is obtained.

6. Reassemble the control box as described in the *Reassembly* instructions, paragraph 5-66.

5-66. Reassembly. Reassemble the control box as follows:

1. Position the case retaining bracket and the connector bracket in their proper positions. (See Figure 5-21 and secure using three and two 6/32 countersunk screws, respectively.)
2. Reinstall the control box case on the control box PWAs, and secure using three 6/32 case-retaining screws and washers (see Figure 5-20).
3. Check that all switches move freely and without restriction.

NOTE

It may be necessary to realign the control box PWAs according to the directions given in the *LED Removal and Replacement* instructions, paragraph 5-65, if the switches bind after the control box case is installed.

4. Connect electrical connector on transport control harness to control box.
5. Position control box on recorder/reproducer (Figure 1-1) and press down firmly to engage plastic retainers.

5-67. Reel Motors

Remove the reel motors as follows:

1. Remove the recorder/reproducer side panel adjacent to the reel motor to be removed.
2. Remove six 10/32 capscrews and No. 10 washers from the reel motor mountings (see Figure 5-24).

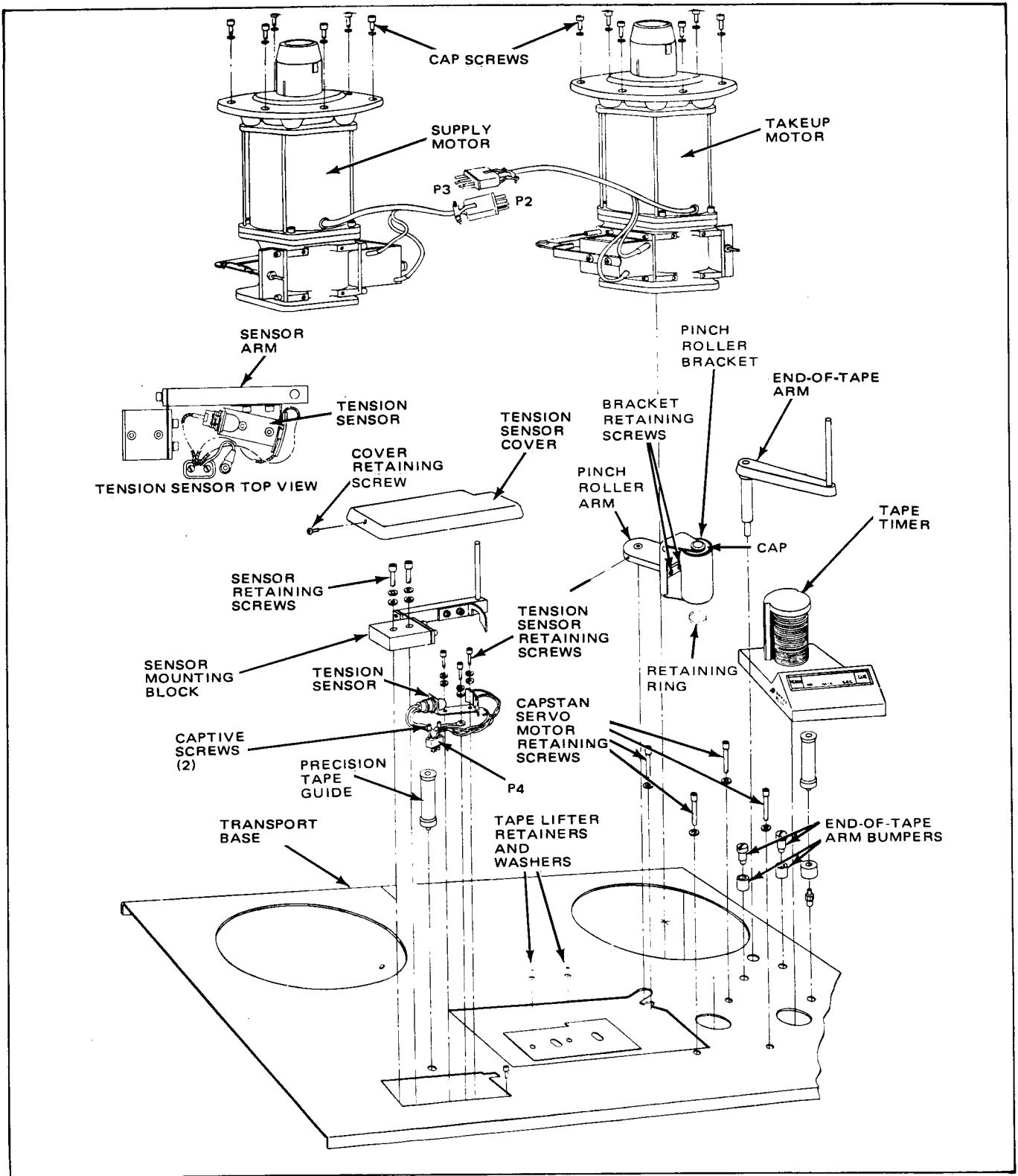

Figure 5-24. Transport Disassembly (Top)

3. Disconnect the reel motor electrical connector (P3 or P2).
4. Carefully remove the reel motor from the top of the transport base.

Replace the reel motors as follows:

1. Carefully insert the reel motor into the transport base. Orient the motor so that the brake assembly sides are parallel to the transport base walls and the brake assembly solenoid is inboard (see Figure 5-11).
2. Align the motor mounting screw holes with the making holes in the transport base.
3. Install the six 10/32 cap screws and No. 10 washers removed previously, and tighten.
4. Reconnect the electrical connector removed previously.
5. Replace the side panel removed previously.

5-68. Capstan Motor

Refer to Figure 5-25 and remove the capstan motor as follows:

1. Remove the recorder/reproducer right side panel.
2. Remove the top two audio electronics assemblies to provide access to the transport base underside.
3. Disconnect the electrical connector in the capstan motor wiring harness.

CAUTION

IN THE FOLLOWING STEP, ENSURE THAT THE CAPSTAN SHAFT IS NOT SCRAPED OR SCUFFED.

4. While supporting the weight of the capstan motor, remove four 10/24 Allen head cap screws and No. 10 washers that secure the capstan motor to the transport base, and remove the capstan motor.

Replace the capstan motor as follows:

CAUTION

IN THE FOLLOWING STEP, ENSURE THAT THE CAPSTAN SHAFT IS NOT SCRAPED OR SCUFFED.

1. Orient the flat side of the capstan motor mounting flange toward the rear of the recorder/reproducer and replace the capstan motor into its mounting position.
2. While supporting the weight of the capstan motor, install the four 10/32 Allen head cap screws and No. 10 washers that secure the capstan motor to the transport base, and tighten.
3. Connect the electrical connector from the capstan motor to its associated connector in the recorder/reproducer harness.
4. Install the electronics assemblies into the recorder/reproducer.
5. Replace the right side panel on the recorder/reproducer.

5-69. Head Assembly

Remove the head assembly as follows:

1. Remove the head cover by grasping and lifting upward.
2. Using a large bladed screwdriver, unscrew the head assembly jackscrew until the head assembly is loose, and remove the head assembly.

Replace the head assembly as follows:

1. Orient the head assembly such that the electrical connectors are mated and the jackscrew is engaged in its proper place.

CAUTION

IN THE FOLLOWING STEP, ENSURE THAT THE HEAD ASSEMBLY DOES NOT BIND WHILE BEING TIGHTENED DOWN AGAINST THE TRANSPORT BASE.

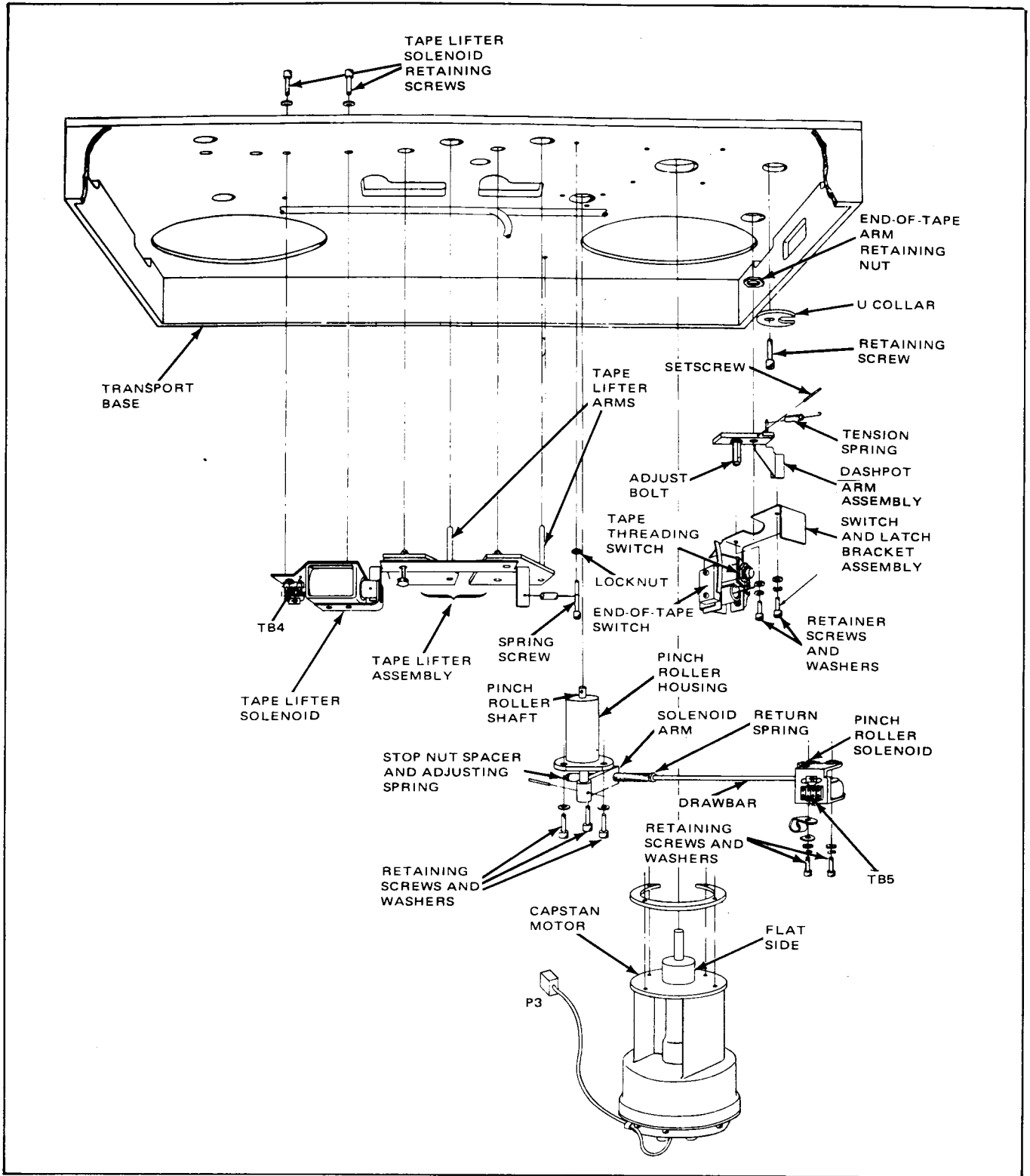

Figure 5-25. Transport Disassembly (Bottom)

- Using a large bladed screwdriver, turn the head assembly jackscrew such that the head assembly mates with the transport base.

NOTE

DO NOT OVERTIGHTEN

- Replace the head cover.

5-70. Tension Sensor

The two individual sections of the tension sensor may be removed separately. Refer to Figure 5-24 and remove the tension sensor arm as follows.

- Remove the tension sensor cover retaining screw and the tension sensor cover.
- Remove the two 6/32 Allen cap screws, two No. 6 lockwashers, and two No. 6 flat washers that secure the sensor arm to the transport base.
- Remove the sensor arm from the transport base.

Replace the sensor arm as follows:

- Position the sensor arm such that the holes in the sensor arm base align with the mating holes in the transport base (see Figure 5-24).
- Secure the sensor arm to the transport base with the two 6/32 Allen cap screws, and four No. 6 washers removed previously.
- Recalibrate the sensor arm in accordance with the procedures provided in *Tension Sensor Arm Calibration*, paragraph 5-17.

Remove the tension sensor as follows:

- Remove the tension sensor cover retaining screw and the tension sensor cover (see Figure 5-24).
- Remove two 6/32 tension sensor retaining screws and No. 6 washers.
- Remove one 6/32 retaining screw and No. 6 washer from the ground lug adjacent to the tension sensor.

- Remove electrical connector (P4) by unscrewing the electrical connector captive screws.
- Slide the tension sensor toward the front of the recorder/reproducer and remove.

Replace the tension sensor as follows:

- Slide the tension sensor under the sensor cover arm and align the mounting holes with the mating holes in the transport base (see Figure 5-24).
- Secure the tension sensor to the transport base with the two 6/32 retaining screws and No. 6 washers removed previously.
- Secure the ground terminal from electrical connector P4 to the transport base using the 6/32 retaining screw and No. 6 washer removed previously.
- Align the electrical connector (P4) into its mating connector in the transport base, and secure using the captive screws.
- Recalibrate the tension sensor assembly in accordance with procedures given in paragraph 5-17.

5-71. Pinch Roller Assembly

Remove the pinch roller and pinch roller bracket as follows:

- Remove the retaining ring from the bottom of the pinch roller shaft (see Figure 5-24).

CAUTION

IN THE FOLLOWING STEP, ENSURE THAT THE SPACER AND THE WAVY WASHER SITUATED BETWEEN THE PINCH ROLLER BOTTOM AND THE PINCH ROLLER BRACKET ARE NOT LOST WHEN THE PINCH ROLLER SHAFT IS REMOVED.

- Remove the pinch roller shaft from the pinch roller bracket and remove the pinch roller.
- Remove two 4/40 cap screws from the pinch roller bracket, and remove the pinch roller bracket from the pinch roller arms.

Reinstall the pinch roller and the pinch roller bracket as follows:

1. Using the two 4/40 cap screws removed previously, secure the pinch roller bracket to the pinch roller arm.
2. Insert the pinch roller into the pinch roller bracket with the cap facing upward.
3. Align the holes in the pinch roller and the pinch roller bracket and insert the pinch roller shaft from the top.
4. Place the wavy washer and the spacer removed previously between the bottom of the pinch roller and the pinch roller bracket, with the spacer placed nearest to the pinch roller.
5. Align the holes in the washer, the pinch roller, and the pinch roller bracket and push the pinch roller shaft through.
6. Secure the lower end of the pinch roller shaft using the retaining ring removed previously.
4. Install the adjusting spring, spacer, and No. 10 stop nut, removed previously, onto the solenoid drawbar.
5. Connect the two wires removed previously to TB5.
6. Adjust the No. 10 stop nut to expose the same number of threads on the solenoid drawbar as noted in step 3 of the pinch roller solenoid removal procedure.
7. Adjust pinch roller pressure as outlined in paragraphs 5-35 and 5-36.

5-72. End-of-Tape Arm and Tape Threading Switch

Remove the pinch roller solenoid (refer to Figure 5-25) as follows:

Remove the end-of-tape arm and threading switch as follows:

1. If not accomplished previously, remove the record/reproducer right side panel.
2. Disconnect two wires from TB5 located on the pinch roller solenoid.
3. Observe and note the number of exposed threads on the end of the solenoid drawbar and remove the No. 10 stop nut, spacer and adjusting spring from the end of the solenoid drawbar.

1. Remove the right side panel from the recorder/reproducer.
2. On the underside of the transport base (see Figure 5-25), loosen the setscrew that secures the dashpot arm assembly to the end-of-tape arm.
3. Remove the end-of-tape arm retaining nut and remove the end-of-tape arm from the transport base (see Figure 5-25).
4. Loosen the dashpot arm adjust bolt and remove the dashpot arm assembly from the transport underside.
5. Disconnect two knife disconnects from the switch and latch bracket assembly to the recorder/reproducer harness.
6. Remove two 8/32 screws and four No. 8 washers that secure the switch and latch bracket assembly to the transport base, and remove the switch and latch bracket assembly.

NOTE

In the following step, ensure that the solenoid return spring is not lost when the solenoid drawbar is removed from the solenoid arm.

4. Remove two 6/32 retaining screws and four No. 6 washers that secure the pinch roller solenoid, and remove the pinch roller solenoid.

Replace the pinch roller solenoid as follows:

Replace the end-of-tape arm and threading switch as follows:

1. Insert the solenoid drawbar, with the return spring in place, into the solenoid arm.
2. Align the pinch roller solenoid with its mating holes in the underside of the transport base.
3. Install the two 6/32 retaining screws and four No. 6 washers removed previously, and tighten.

1. Align the mating holes in the switch and latch bracket assembly with the mating holes in the transport base (see Figure 5-25).
2. Insert two 8/32 retaining screws and four No. 8 washers and tighten to secure the switch and latch bracket.
3. Place the dashpot arm in its appropriate position adjacent to the switch and latch bracket assembly, and insert the dashpot wire into the dashpot adjust bolt.
4. Insert the end-of-tape arm through the top of the transport base, install the end-of-tape arm retaining nut, mate the end-of-tape arm shaft with the dashpot arm assembly, and tighten the setscrew lightly.
5. Connect the knife disconnects removed previously, insulate disconnects, and secure.
6. Replace the recorder/reproducer right side panel.
7. Perform the adjustment procedure, paragraph 5-37.

5-73. Search-to-Cue and Tape Timer Assembly

Remove the search-to-cue and tape timer assembly as follows:

1. Remove the right side panel from the recorder/reproducer.
2. Disconnect the search-to-cue and tape timer assembly electrical connector beneath the control box bracket.
3. Remove the 10/32 retaining screw, No. 10 washer, and U collar that secures the assembly to the transport base.
4. Remove the assembly from the top of the transport base.

Replace the search-to-cue and tape timer assembly as follows:

1. Feed the search-to-cue and tape timer assembly electrical connector and harness through the mating hole (see Figure 5-25) in the transport base, and place the assembly in position on the transport base.
2. On the transport base underside, place the U collar in position and insert the 10/32 retaining screw and No. 10 washer removed previously.
3. Ensure that the front bezel of the search-to-cue and tape timer assembly is parallel to the front edge of the transport base (see Figure 1-3), and tighten the U collar retaining screw.
4. Connect the electrical connectors removed previously.
5. Replace the recorder/reproducer right side panel.

5-74 Tape Lifter Assembly

Remove the tape lifter assembly and its associated solenoid as follows:

1. Remove the left side panel from the recorder/reproducer.
2. Remove two terminal lugs from TB4 located on the tape lifter assembly solenoid on the underside of the transport base (see Figure 5-25).
3. Remove two tape lifter solenoid retaining screws.
4. While supporting the tape lifter assembly on the underside of the transport base, remove two Truarc retainers and washers on the top-side of the transport base (see Figure 5-24). Remove the tape lifter assembly and solenoid.

Replace the tape lifter assembly and solenoid as follows:

1. Align the tape lifter assembly and solenoid with the mating holes in the transport base.

2. Install the Truarc retainers and washers removed previously to secure the tape lifter assembly to the transport base.
3. Insert the solenoid retaining screws and washers removed previously.
4. Reconnect the terminal lugs removed previously to TB4, located on the tape lifter solenoid assembly.
5. Replace the recorder/reproducer left side panel.
6. Perform the tape lifter adjustment procedure, paragraph 5-31 in this manual.

5-75. Power Supply

Remove the power supply as follows:

1. Remove the ac power plug from the ac source.
2. Remove the recorder/reproducer right side panel.
3. Remove four screws and countersunk washers that secure the power supply cover panel, and remove the cover panel.
4. Remove four 10/32 screws and No. 10 counter-sunk washers that secure the power supply to the frame.

WARNING

THE POWER SUPPLY IS VERY HEAVY DUE TO THE LARGE POWER TRANSFORMER CONTAINED THEREIN. EXERCISE EXTREME CARE IN REMOVING THE POWER SUPPLY TO PREVENT INJURY TO PERSONNEL, OR DAMAGE TO EQUIPMENT.

5. Place two four-by-four-inch wood blocks (or equivalent) adjacent to the recorder/reproducer frame such that external support will be provided for the power supply removal.
6. Slide the power supply out of the frame and rest it on the wood blocks.

7. Remove six electrical connectors from the rear of the power supply and remove the power supply.

Replace the power supply as follows:

1. Place the power supply on two four-by-four-inch wood blocks (or equivalent) adjacent to the recorder/reproducer such that the electrical connectors removed previously may be installed.
2. Reinstall the six electrical connectors removed previously.
3. Slide the power supply into the recorder/reproducer while ensuring that the electrical harnesses do not become entangled.
4. Replace four 10/32 retaining screws and No. 10 countersunk washers that secure the power supply.
5. Replace the power supply cover panel and secure using the four retaining screws and countersunk washers removed previously.
6. Replace the recorder/reproducer right side panel.

5-76. Motor Drive Amplifier Assembly

Remove the MDA assembly as follows:

1. Remove the recorder/reproducer left side panel.
2. Remove four 10/32 retaining screws and No. 10 countersunk washers, and remove the MDA assembly.
3. Remove one electrical connector from the MDA assembly.

Replace the MDA assembly as follows:

1. Reconnect the electrical connector removed previously.
2. Install the MDA in its position in the recorder/reproducer.

3. Secure the MDA with the four 10/32 retaining screws and No. 10 countersunk washers removed previously.
4. Reinstall the recorder/reproducer left side panel.

5-77. Meter Panel Assembly

Remove and replace the meter panel lamp bulbs as follows:

1. Move the meter panel to its down position. (Ensure that the electronics assembly doors are closed.)
2. Remove and replace the meter lamp (Ampex Part No. 060-044) by removing the lamp socket from the rear of the meter.
3. Reinstall the lamp socket into the meter, and move the meter panel to the closed position or other viewing positions as desired.

SECTION 6

PARTS LISTS AND SCHEMATICS

This section of the manual provides parts lists, assembly drawings and schematic diagrams for the MM-1200 Recorder/Reproducer, Ampex Part No. 4010240.

Three indexes list the assemblies as follows:

- **Indented List of Assemblies** — List of assemblies in sequence of appearance in the manual.
- **Numerical List of Assemblies** — List of assemblies in numeric sequence.
- **Numerical List of Schematics** — List of schematics in numeric sequence.

INDENTURED LIST OF ASSEMBLIES

| TITLE | ASSEMBLY NO. | PAGE NO. |
|--------------------------------------------------------------------|--------------|----------|
| System | | |
| MM-1200 Multichannel Recorder/Reproducer Assembly | 4010240 | 6-1 |
| Transport Assembly | | |
| Transport Assembly | 4020401 | 6-11 |
| Search-to-Cue/Timer Tachometer Display Assembly | 4020414 | 6-14 |
| Tape Timer Idler and Shaft Assembly | 4041207 | 6-17 |
| Search-to-Cue/Timer Display PWA | 4050810 | 6-18 |
| Search-to-Cue/Timer Display Driver PWA | 4050809 | 6-21 |
| Tachometer Preamplifier PWA | 4050783 | 6-23 |
| Capstan Drive Assembly | 4030328 | 6-24 |
| Capstan Drive Coil Support and Pickup Assembly | 4030322 | 6-26 |
| Switch and Latch Bracket Assembly | 4030341 | 6-27 |
| Capstan Idler Housing Assembly | 4041270 | 6-28 |
| Capstan Idler Arm Assembly | 4030372 | 6-29 |
| Reel Motor Assembly, Takeup and Supply (with Schematic) | 4030375 | 6-30 |
| Reel Motor Solenoid Assembly | 4030417 | 6-33 |
| Solenoid Assembly | 4030418 | 6-34 |
| End-of-Tape Arm and Housing Assembly | 4030377 | 6-35 |
| Tape Lifter Assembly | 4030376 | 6-36 |
| Tension Sensor Assembly | 4030384 | 6-38 |
| Tape Guide Idler Assembly, Two-Inch (16- and 24-Channel) | 1376517 | 6-39 |
| Tape Guide Idler Assembly, One-Inch (8-Channel) | 4030410 | 6-40 |
| Transport Tension Arm Assembly | 4041194 | 6-41 |
| Tape Transport Harness Assembly | 4050775 | 6-42 |
| Dashpot Arm Assembly | 4952589 | 6-45 |
| Capstan Solenoid Assembly | 55670 | 6-46 |
| Electronics Assembly | | |
| Electronics Assembly | 4020402 | 6-49 |
| Bias Amplifier PWA | 4050433 | 6-53 |
| Record Amplifier PWA | 4050434 | 6-57 |
| Reproduce Amplifier PWA | 4050435 | 6-61 |
| Record Equalizer PWA | 4020269 | 6-65 |
| Reproduce Equalizer PWA | 4020270 | 6-71 |
| Rear Panel Assembly | 4050765 | 6-72 |
| Rear Panel Harness Assembly | 4050767 | 6-74 |
| Motherboard PWA | 4050777 | 6-75 |
| Audio Switching PWA | 4050774 | 6-79 |

INDENTURED LIST OF ASSEMBLIES (Continued)

| TITLE | ASSEMBLY NO. | PAGE NO. |
|---------------------------------------------------------------|--------------|----------|
| MM-1200 Multichannel Recorder/Reproducer Assembly (Continued) | | |
| Head Assemblies | | |
| One-Inch Head Assembly, 8-Channel | 4020334 | 6-83 |
| Head Gate Assembly, One-Inch, Two-Inch | 4030386 | 6-85 |
| Scrape Flutter Idler Assembly, One-Inch | 4041048 | 6-86 |
| Two-Inch Head Assembly, 16- and 24-Channel | 4020372 | 6-87 |
| Head Gate Assembly (See page 6-85) | 4030386 | |
| Scrape Flutter Idler Assembly, Two-Inch | 4952442 | 6-89 |
| Motor Drive Amplifier Assembly | | |
| Motor Drive Amplifier Assembly | 4020392 | 6-91 |
| Motor Drive Amplifier Fan Assembly | 4030354 | 6-95 |
| Motor Drive Amplifier Harness Assembly | 4050768 | 6-96 |
| Motor Drive Amplifier PWA | 4050771 | 6-97 |
| Power Supply Assembly | | |
| Power Supply Assembly | 4020393 | 6-99 |
| Power Supply Heatsink Assembly | 4030355 | 6-105 |
| Power Supply Fuse Panel Assembly | 4030356 | 6-108 |
| Regulator PWA | 4050699 | 6-109 |
| Power Supply Harness Assembly | 4050797 | 6-115 |
| Transport Control Chassis Assembly | | |
| Transport Control Chassis Assembly | 4020403 | 6-117 |
| Capstan Servo PWA | 4050692 | 6-121 |
| Transport Control PWA | 4050864 | 6-125 |
| Search-to-Cue/Timer PWA | 4050808 | 6-129 |
| Transport Control Harness Assembly | 4050790 | 6-131 |
| Control Box Assembly | | |
| Control Box Assembly | 4020394 | 6-133 |
| LED Board PWA | 4050756 | 6-137 |
| Switchboard PWA | 4050757 | 6-138 |
| Indicator Logic PWA | 4050772 | 6-140 |

INDENTURED LIST OF ASSEMBLIES (Continued)

| TITLE | ASSEMBLY NO. | PAGE NO. |
|---------------------------------------------------------------|--------------|----------|
| MM-1200 Multichannel Recorder/Reproducer Assembly (Continued) | | |
| Control Box Assembly (Continued) | | |
| Control Box Assembly (Continued) | | |
| Standby Switcher Control Box PWA | 4050854 | 6-141 |
| Control Box Connector Harness Assembly | 4050773 | 6-142 |
| Miscellaneous Assemblies | | |
| Console Frame Assembly | 4030351 | 6-143 |
| Power Switch Housing Assembly (with Wiring Diagram) | 4030370 | 6-145 |
| Fan Panel Assembly | 4030419 | 6-146 |
| Input/Output Connector Panel Assembly | 4050798 | 6-147 |
| Erase Head Cable Assembly (with Wiring Diagram) | 4050686 | 6-148 |
| Reproduce Head Cable Assembly (with Wiring Diagram) | 4050687 | 6-149 |
| Record Head Cable Assembly (with Wiring Diagram) | 4050688 | 6-150 |
| Electronics Power and Control Cable Assembly | 4050770 | 6-151 |
| Meter Panel Assembly | 4050805 | 6-155 |
| Meter Panel Cable Assembly (with Wiring Diagram) | 4050682 | 6-159 |
| AC Outlet Assembly (with Wiring Diagram) | 4050789 | 6-160 |
| Miscellaneous Parts Kit | 4010248 | 6-161 |
| Extender Board Assembly | 4050695 | 6-162 |
| Remote Control Dummy Plug Assembly | 4050710 | 6-163 |
| Rear Transport Panel Assembly | 4050857 | 6-164 |
| Accessories | | |
| MM-1200 Accessories | 4010239 | 6-165 |
| Conversion Kit, 8- to 16-Channel | 4010246 | 6-166 |
| Conversion Kit, 16- to 24-Channel | 4010247 | 6-167 |
| Reproduce Module Extender Board Assembly | 4020151 | 6-168 |
| Record Module Extender Board Assembly | 4020152 | 6-169 |
| Bias Amplifier Extender Board Assembly | 4020153 | 6-170 |
| Power Supply Extender Board Assembly | 4020154 | 6-171 |
| AC Outlet Assembly (See page 6-160) | 4050789 | |
| Search-to-Cue and Timer Remote Display Assembly | 4020410 | 6-173 |
| Search-to-Cue/Timer PWA (See page 6-123) | 4050810 | |
| Motor Drive Amplifier Extender PWA | 4050801 | 6-177 |
| Conversion Kit, Two-Inch to One-Inch | 4050154 | 6-178 |
| Control Box Assembly, Transport Only | 4020411 | 6-179 |
| Connector Harness Assembly | 4050816 | 6-183 |

INDENTURED LIST OF ASSEMBLIES (Continued)

| TITLE | ASSEMBLY NO. | PAGE NO. |
|------------------------------------------------------------------|--------------|----------|
| MM-1200 Multichannel Recorder/Reproducer Assembly (Continued) | | |
| Accessories (Continued) | | |
| MM-1200 Accessories (Continued) | | |
| Remote Interconnect Cable Assembly | 4952348 | 6-184 |
| Search-to-Cue/Timer Display Driver PWA (See page 6-21) | 4050809 | |
| Brush Assembly Replacement Kit and Procedure | 4030414 | 6-185 |
| Switcher Extender PWA | 4050803 | 6-186 |
| Overhead Bridge Assembly | 4010242 | 6-188 |

NUMERICAL LIST OF ASSEMBLIES

| ASSEMBLY NO. | REV. | TITLE | PAGE NO. |
|--------------|------|-----------------------------------------------------------------------|----------|
| 55670 | U | Capstan Solenoid Assembly | 6-46 |
| 1376517 | A | Tape Guide Idler Assembly, Two-Inch (16- and 24-Channel) | 6-39 |
| 4010239 | K | MM-1200 Accessories | 6-165 |
| 4010240 | S | MM-1200 Multichannel Recorder/Reproducer Assembly | 6-1 |
| 4010242 | E | Overhead Bridge Assembly | 6-188 |
| 4010246 | C | Conversion Kit, 8- to 16-Channel | 6-166 |
| 4010247 | A | Conversion Kit, 16- to 24-Channel | 6-167 |
| 4010248 | G | Miscellaneous Parts Kit | 6-161 |
| 4020151 | E | Reproduce Module Extender Board Assembly | 6-168 |
| 4020152 | C | Record Module Extender Board Assembly | 6-169 |
| 4020153 | D | Bias Amplifier Extender Board Assembly | 6-170 |
| 4020154 | C | Power Supply Extender Board Assembly | 6-171 |
| 4020269 | J | Record Equalizer PWA, | 6-65 |
| 4020270 | D | Reproduce Equalizer PWA | 6-71 |
| 4020334 | K | One-Inch Head Assembly, 8-Channel | 6-83 |
| 4020372 | N | Two-Inch Head Assembly, 16- and 24-Channel | 6-87 |
| 4020392 | J | Motor Drive Amplifier Assembly | 6-91 |
| 4020393 | K | Power Supply Assembly | 6-99 |
| 4020394 | N | Control Box Assembly | 6-133 |
| 4020401 | H | Transport Assembly | 6-11 |
| 4020402 | E | Electronics Assembly | 6-49 |
| 4020403 | P | Transport Control Chassis Assembly | 6-117 |
| 4020410 | F | Search-to-Cue and Timer Remote Display Assembly | 6-173 |
| 4020411 | C | Control Box Assembly, Transport Only | 6-179 |
| 4020414 | M | Search-to-Cue/Timer Tachometer Display Assembly | 6-14 |
| 4030328 | Y | Capstan Drive Assembly | 6-24 |
| 4030332 | D | Capstan Drive Coil Support and Pickup Assembly | 6-26 |
| 4030341 | C | Switch and Latch Bracket Assembly | 6-27 |
| 4030351 | H | Console Frame Assembly | 6-143 |
| 4030354 | D | Motor Drive Amplifier Fan Assembly | 6-95 |
| 4030355 | E | Power Supply Heatsink Assembly | 6-105 |
| 4030356 | G | Power Supply Fuse Panel Assembly | 6-108 |
| 4030370 | C | Power Switch Housing Assembly | 6-145 |
| 4030372 | A | Capstan Idler Arm Assembly | 6-29 |
| 4030375 | G | Reel Motor Assembly, Takeup and Supply | 6-30 |
| 4030376 | E | Tape Lifter Assembly | 6-36 |
| 4030377 | A | End-of-Tape Arm and Housing Assembly | 6-35 |

NUMERICAL LIST OF ASSEMBLIES (Continued)

| ASSEMBLY NO. | REV. | TITLE | PAGE NO. |
|--------------|------|--------------------------------------------------------|----------|
| 4030384 | C | Tension Sensor Assembly | 6-38 |
| 4030386 | — | Head Gate Assembly, One-Inch, Two-Inch | 6-85 |
| 4030410 | A | Tape Guide Idler Assembly, One-Inch | 6-40 |
| 4030414 | A | Brush Assembly Replacement Kit | 6-185 |
| 4030417 | A | Reel Motor Solenoid Assembly | 6-33 |
| 4030418 | A | Solenoid Assembly | 6-34 |
| 4030419 | — | Fan Panel Assembly | 6-146 |
| 4041048 | C | Scrape Flutter Idler Assembly, One-Inch | 6-86 |
| 4041194 | D | Tension Arm Assembly, Transport | 6-41 |
| 4041207 | C | Tape Timer Idler and Shaft Assembly | 6-17 |
| 4041270 | — | Capstan Idler Housing Assembly | 6-28 |
| 4050433 | M | Bias Amplifier PWA | 6-53 |
| 4050434 | L | Record Amplifier PWA | 6-57 |
| 4050435 | AG | Reproduce Amplifier PWA | 6-61 |
| 4050682 | D | Meter Panel Cable Assembly | 6-159 |
| 4050686 | C | Erase Head Cable Assembly | 6-148 |
| 4050687 | C | Reproduce Head Cable Assembly | 6-149 |
| 4050688 | A | Record Head Cable Assembly | 6-150 |
| 4050692 | H | Capstan Servo PWA | 6-121 |
| 4050695 | F | Extender Board Assembly | 6-162 |
| 4050699 | K | Regulator PWA | 6-109 |
| 4050710 | B | Remote Control Dummy Plug Assembly | 6-163 |
| 4050756 | B | LED Board PWA | 6-137 |
| 4050757 | G | Switchboard PWA | 6-138 |
| 4050765 | E | Rear Panel Assembly | 6-72 |
| 4050767 | C | Rear Panel Harness Assembly | 6-74 |
| 4050768 | B | Motor Drive Amplifier Harness Assembly | 6-96 |
| 4050770 | B | Electronics Power and Control Cable Assembly | 6-151 |
| 4050771 | J | Motor Drive Amplifier PWA | 6-97 |
| 4050772 | — | Indicator Logic PWA | 6-140 |
| 4050773 | E | Control Box Connector Harness Assembly | 6-142 |
| 4050774 | F | Audio Switching PWA | 6-79 |
| 4050775 | D | Tape Transport Harness Assembly | 6-42 |
| 4050777 | D | Motherboard PWA | 6-75 |
| 4050783 | F | Tachometer Preamplifier PWA | 6-23 |
| 4050789 | D | AC Outlet Assembly | 6-160 |
| 4050790 | H | Transport Control Harness Assembly | 6-131 |
| 4050797 | E | Power Supply Harness Assembly | 6-115 |
| 4050798 | C | Input/Output Connector Panel Assembly | 6-147 |

NUMERICAL LIST OF ASSEMBLIES (Continued)

| ASSEMBLY NO. | REV. | TITLE | PAGE NO. |
|--------------|------|---------------------------------------------------|----------|
| 4050801 | A | Motor Drive Amplifier Extender PWA | 6-177 |
| 4050803 | A | Switcher Extender PWA | 6-186 |
| 4050805 | G | Meter Panel Assembly | 6-155 |
| 4050808 | F | Search-to-Cue/Timer PWA | 6-129 |
| 4050809 | C | Search-to-Cue/Timer Display Driver PWA | 6-21 |
| 4050810 | C | Search-to-Cue/Timer Display PWA | 6-18 |
| 4050816 | B | Connector Harness Assembly | 6-183 |
| 4050854 | A | Standby Switcher Control Box PWA | 6-141 |
| 4050857 | B | Rear Transport Panel Assembly | 6-164 |
| 4050864 | — | Transport Control PWA | 6-125 |
| 4850154 | C | Conversion Kit, Two-Inch to One-Inch | 6-178 |
| 4952348 | M | Remote Interconnect Cable Assembly | 6-184 |
| 4952442 | C | Scrape Flutter Idler Assembly, Two-Inch | 6-89 |
| 4952589 | H | Dashpot Arm Assembly | 6-45 |

NUMERICAL LIST OF SCHEMATICS

| SCHEMATIC NO. | REV. | TITLE | PAGE NO. |
|---------------|------|--------------------------------------------------------------------------|----------|
| 4030375 | G | Reel Motor Assembly, Takeup and Supply | 6-31 |
| 4050682 | D | Meter Panel Cable Assembly | 6-159 |
| 4050686 | C | Erase Head Cable Assembly | 6-148 |
| 4050688 | A | Record Head Cable Assembly | 6-150 |
| 4050789 | E | AC Outlet Assembly | 6-160 |
| 4840249 | D | Bias Amplifier PWA | 6-55 |
| | | Reproduce Amplifier PWA, 7-1/2 - 15 In/S | 6-55 |
| 4840330 | C | Reproduce Equalizer PWA, 7-1/2 - 15 IN/S | 6-69 |
| | | Record Equalizer PWA, 7-1/2 - 15 In/S | 6-69 |
| 4840337 | F | Regulator PWA, 39V | 6-111 |
| 4040339 | E | Regulator PWA, 15/27V | 6-113 |
| 4840356 | F | Capstan Servo PWA | 6-123 |
| 4840372 | F | Record Equalizer PWA, 15 - 30 In/S | 6-67 |
| | | Reproduce Equalizer PWA, 15 - 30 In/S | 6-67 |
| 4840388 | C | Audio Switching PWA | 6-81 |
| 4840391 | B | Motherboard PWA | 6-77 |
| 4840393 | F | Motor Drive Amplifier Assembly | 6-93 |
| 4840399 | B | Tape Transport Harness Wiring Diagram | 6-43 |
| 4840401 | — | Electronics Power and Control Cable Assembly Wiring Diagram | 6-153 |
| 4840402 | D | Transport Control Chassis Assembly Wiring Diagram | 6-119 |
| 4840404 | G | Power Supply Assembly | 6-103 |
| 4840408 | B | Electronics Assembly Interconnect Diagram | 6-51 |
| 4840414 | B | Meter Panel Assembly Wiring Diagram | 6-157 |
| 4840417 | J | Search-to-Cue/Timer Display PWA | 6-19 |
| | | Search-to-Cue/Timer Display Driver PWA | 6-19 |
| | | Tachometer Preamplifier PWA | 6-19 |
| 4840424 | A | Search-to-Cue and Timer Remote Display Assembly | 6-175 |
| 4840426 | A | Control Box Assembly, Transport Only | 6-181 |
| 4840430 | B | Control Box Assembly | 6-135 |
| 4840431 | — | Electronics | 6-59 |
| 4840433 | B | MM-1200 Multichannel Recorder/Reproducer Assembly | 6-5 |
| 4840438 | B | Transport Control PWA | 6-127 |
| 4840463 | — | Electronics Bay | 6-63 |

| ITEM NO. | AMPEX PART NO. | REFERENCE NUMBER | DESCRIPTION | JEDEC NO. OR MFR. PART NO. |
|----------|----------------|------------------|-------------------------------------------------------------------------------------------------------------------------------------------------------------------------------------------------------------|----------------------------|
| | 4010240-13 | | MM-1200 MULTICHANNEL RECORDER/REPRODUCER ASSEMBLY, 8 CHANNEL, NAB, 15-30 IN/S (NHA CATALOG) | |
| | 4010240-14 | | MM-1200 MULTICHANNEL RECORDER/REPRODUCER ASSEMBLY, 16 CHANNEL, NAB, 15-30 IN/S (NHA CATALOG) | |
| | 4010240-15 | | MM-1200 MULTICHANNEL RECORDER/REPRODUCER ASSEMBLY, 24 CHANNEL, NAB, 15-30 IN/S (NHA CATALOG) | |
| | 4010240-16 | | MM-1200 MULTICHANNEL RECORDER/REPRODUCER ASSEMBLY, 8 CHANNEL, CCIR/IEC, 15-30 IN/S (NHA CATALOG) | |
| | 4010240-17 | | MM-1200 MULTICHANNEL RECORDER/REPRODUCER ASSEMBLY, 16 CHANNEL, CCIR/IEC, 15-30 IN/S (NHA CATALOG) | |
| | 4010240-18 | | MM-1200 MULTICHANNEL RECORDER/REPRODUCER ASSEMBLY, 24 CHANNEL, CCIR/IEC, 15-30 IN/S (NHA CATALOG) | |
| | 4010240-19 | | MM-1200 MULTICHANNEL RECORDER/REPRODUCER ASSEMBLY, 8 CHANNEL, NAB, 7.5-15 IN/S (NHA CATALOG) | |
| | 4010240-20 | | MM-1200 MULTICHANNEL RECORDER/REPRODUCER ASSEMBLY, 16 CHANNEL, NAB, 7.5-15 IN/S (NHA CATALOG) | |
| | 4010240-21 | | MM-1200 MULTICHANNEL RECORDER/REPRODUCER ASSEMBLY, 24 CHANNEL, NAB, 7.5-15 IN/S (NHA CATALOG) | |
| | 4010240-22 | | MM-1200 MULTICHANNEL RECORDER/REPRODUCER ASSEMBLY, 8 CHANNEL, CCIR/IEC, 7.5-15 IN/S (NHA CATALOG) | |
| | 4010240-23 | | MM-1200 MULTICHANNEL RECORDER/REPRODUCER ASSEMBLY, 16 CHANNEL, CCIR/IEC, 7.5-15 IN/S (NHA CATALOG) | |
| | 4010240-24 | | MM-1200 MULTICHANNEL RECORDER/REPRODUCER ASSEMBLY, 24 CHANNEL, CCIR/IEC, 7.5-15 IN/S (NHA CATALOG) | |
| 1 | 4020269-01 | | | |
| 2 | 4020269-03 | | | |
| 3 | 4020269-06 | | | |
| 4 | 4020269-08 | | | |
| 6 | 4020270-02 | | RECORD EQUALIZER PWA, NAB, 7-1/2-15 IN/S RECORD EQUALIZER PWA, CCIR 7-1/2-15 IN/S RECORD EQUALIZER PWA, CCIR/IEC, 15-30 IN/S RECORD EQUALIZER PWA, NAB, 15-30 IN/S REPRODUCE EQUALIZER PWA, NAB | |
| 9 | 4020334-03 | | | |
| 10 | 4020334-04 | | ONE-INCH HEAD ASSEMBLY, 8 CHANNEL, 15-30 IN/S | |
| 12 | 4020372-05 | | ONE-INCH HEAD ASSEMBLY, 8 CHANNEL, 7.5-15 IN/S | |
| 13 | 4020372-06 | | TWO-INCH HEAD ASSEMBLY, 16 CHANNEL, 15-30 IN/S | |
| 14 | 4020372-07 | | TWO-INCH HEAD ASSEMBLY, 24 CHANNEL, 15-30 IN/S | |
| 15 | 4020372-08 | | TWO-INCH HEAD ASSEMBLY, 16 CHANNEL, 7.5-15 IN/S | |
| 18 | 4020401-01 | | | |
| 19 | 4020401-02 | | TRANSPORT ASSEMBLY, 8 CHANNEL | |
| 21 | 4840433 | | TRANSPORT ASSEMBLY, 16, 24 CHANNEL SCHEMATIC | |
| 22 | 4020402-05 | | ELECTRONICS ASSEMBLY, 15-30 IN/S | |
| 23 | 4020402-06 | | | |
| 25 | 4020392-02 | | ELECTRONICS ASSEMBLY, 7.5-15 IN/S | |
| 27 | 4020393-04 | | MOTOR DRIVE AMPLIFIER ASSEMBLY | |
| 29 | 4020403-04 | | POWER SUPPLY ASSEMBLY | |
| 31 | 4020394-04 | | TRANSPORT CONTROL CHASSIS ASSEMBLY CONTROL BOX ASSEMBLY, 8 CHANNEL | |

S

SHEET 1 OF 3

| ITEM NO. | AMPEX PART NO. | REFERENCE NUMBER | DESCRIPTION | JEDEC NO. OR MFR. PART NO. |
|----------|----------------|------------------|--------------------------------------------------------------|----------------------------|
| 32 | 4020394-05 | | CONTROL BOX ASSEMBLY, 16 CHANNEL | |
| 33 | 4020394-06 | | CONTROL BOX ASSEMBLY, 24 CHANNEL | |
| 36 | 4030351-01 | | CONSOLE FRAME ASSEMBLY | |
| 37 | 4030370-02 | | POWER SWITCH HOUSING ASSEMBLY | |
| 38 | 4030387-05 | | CONSOLE DOOR ASSEMBLY, LEFT HAND | |
| 39 | 4030387-06 | | CONSOLE DOOR ASSEMBLY, RIGHT HAND | |
| 41 | 4030419-01 | | FAN PANEL ASSEMBLY | |
| 42 | 4050798-01 | | INPUT/OUTPUT CONNECTOR PANEL ASSEMBLY, 8 CHANNEL | |
| 43 | 4050798-02 | | INPUT/OUTPUT CONNECTOR PANEL ASSEMBLY, 16 CHANNEL | |
| 44 | 4050798-03 | | INPUT/OUTPUT CONNECTOR PANEL ASSEMBLY, 24 CHANNEL | |
| 45 | 4050686-04 | | ERASE HEAD CABLE ASSEMBLY | |
| 46 | 4050686-05 | | ERASE HEAD CABLE ASSEMBLY, 16, 24 CHANNEL | |
| 47 | 4050686-06 | | ERASE HEAD CABLE ASSEMBLY, 24 CHANNEL | |
| 50 | 4050687-07 | | REPRODUCE HEAD CABLE ASSEMBLY | |
| 51 | 4050687-08 | | REPRODUCE HEAD CABLE ASSEMBLY, 16, 24 CHANNEL | |
| 52 | 4050687-09 | | REPRODUCE HEAD CABLE ASSEMBLY, 24 CHANNEL | |
| 54 | 4050688-04 | | RECORD HEAD CABLE ASSEMBLY | |
| 55 | 4050688-05 | | RECORD HEAD CABLE ASSEMBLY, 16, 24 CHANNEL | |
| 56 | 4050688-06 | | RECORD HEAD CABLE ASSEMBLY, 24 CHANNEL | |
| 59 | 4050710-01 | | REMOTE CONTROL DUMMY PLUG ASSEMBLY | |
| 63 | 4050805-01 | | METER PANEL ASSEMBLY, 8 CHANNEL | |
| 64 | 4050805-02 | | METER PANEL ASSEMBLY, 16 CHANNEL | |
| 65 | 4050805-03 | | METER PANEL ASSEMBLY, 24 CHANNEL | |
| 67 | 4050770-01 | | ELECTRONICS POWER AND CONTROL CABLE ASSEMBLY | |
| 68 | 4050770-02 | | ELECTRONICS POWER AND CONTROL CABLE ASSEMBLY, 16, 24 CHANNEL | |
| 69 | 4050770-03 | | ELECTRONICS POWER AND CONTROL CABLE ASSEMBLY, 24 CHANNEL | |
| 70 | 4260568-02 | | BRACKET, DUMMY AC OUTPUT | |
| 72 | 4010248-01 | | MISCELLANEOUS PARTS KIT, 8 CHANNEL | |
| 73 | 4010248-02 | | MISCELLANEOUS PARTS KIT, 16,24 CHANNEL | |
| 78 | 4110273-99 | | LABEL, IDENTIFICATION | |
| 80 | 4100079-01 | | BUTTON, ELEC, CH. 1 | |
| 81 | 4100079-02 | | BUTTON, ELEC, CH. 2 | |
| 82 | 4100079-03 | | BUTTON, ELEC, CH. 3 | |
| 83 | 4100079-04 | | BUTTON, ELEC, CH. 4 | |
| 84 | 4100079-05 | | BUTTON, ELEC, CH. 5 | |
| 85 | 4100079-06 | | BUTTON, ELEC, CH. 6 | |
| 86 | 4100079-07 | | BUTTON, ELEC, CH. 7 | |
| 87 | 4100079-08 | | BUTTON, ELEC, CH. 8 | |
| 88 | 4100079-09 | | BUTTON, ELEC, CH. 9 | |
| 89 | 4100079-10 | | BUTTON, ELEC, CH. 10 | |
| 90 | 4100079-11 | | BUTTON, ELEC, CH. 11 | |
| 91 | 4100079-12 | | BUTTON, ELEC, CH. 12 | |
| 92 | 4100079-13 | | BUTTON, ELEC, CH. 13 | |
| 93 | 4100079-14 | | BUTTON, ELEC, CH. 14 | |
| 94 | 4100079-15 | | BUTTON, ELEC, CH. 15 | |
| 95 | 4100079-16 | | BUTTON, ELEC, CH. 16 | |
| 96 | 4100079-17 | | BUTTON, ELEC, CH. 17 | |
| 97 | 4100079-18 | | BUTTON, ELEC, CH. 18 | |
| 98 | 4100079-19 | | BUTTON, ELEC, CH. 19 | |

S

| ITEM NO. | AMPEX PART NO. | REFERENCE NUMBER | DESCRIPTION | JEDEC NO. OR MFR. PART NO. |
|----------|----------------|------------------|-----------------------------------------------------|----------------------------|
| 99 | 4100079-20 | | BUTTON, ELEC, CH. 20 | |
| 100 | 4100079-21 | | BUTTON, ELEC, CH. 21 | |
| 101 | 4100079-22 | | BUTTON, ELEC, CH. 22 | |
| 102 | 4100079-23 | | BUTTON, ELEC, CH. 23 | |
| 103 | 4100079-24 | | BUTTON, ELEC, CH. 24 | |
| 105 | 4120028-01 | | STOP, DOOR, MODIFICATION | |
| 106 | 4170325-01 | | LABEL, TENSION | |
| 107 | 4200069-01 | | SLEEVE, TAPE GUIDE | |
| 111 | 4220305-01 | | SPACER, TRANSPORT | |
| 114 | 4260527-03 | | BRACKET, METER PANEL, LEFT | |
| 115 | 4260527-04 | | BRACKET, METER PANEL, RIGHT | |
| 116 | 4260530-02 | | ANGEL, CONTROL PANEL | |
| 118 | 4290825-13 | | PANEL, SIDE, LEFT | |
| 119 | 4290825-14 | | PANEL, SIDE, RIGHT | |
| 120 | 4050857-01 | | PANEL ASSEMBLY, REAR, TRANSPORT | |
| 122 | 4290836-02 | | PANEL, FILLER, 8, 16 CHANNEL | |
| 123 | 4290829-01 | | PANEL, FILLER, REAR, 8, 16 CHANNEL | |
| 124 | 4290773-02 | | COVER, POWER SUPPLY | |
| 125 | 1374158-01 | | FILTER | |
| 129 | 4330335-01 | | PLATE, CLAMP, CABLE, LARGE | |
| 130 | 4330336-01 | | PLATE, CLAMP, CABLE, SMALL | |
| 131 | 4420060-01 | | NUT PLATE, DOOR STOP | |
| 133 | 4600085-01 | | CLAMP, CABLE | |
| 134 | 421-342 | | BEARING, 0.255 I.D. X 0.62 O.D. X 0.06 THK | |
| 136 | 280-900 | | STANDOFF, SST, 0.171 I.D. X 0.250 O.D. X 0.250 LG | |
| 137 | 471-062 | | SCREW, PAN HD, XREC, 4-40 X 0.375 LG | |
| 138 | 470-038 | | SCREW, CAP HEX, SOC HD, NO. 10-32 X 0.50 LG | |
| 139 | 470-029 | | SCREW, CAP HEX, SOC HD NO. 8-32 X 0.50 LG. | |
| 140 | 471-069 | | SCREW, PAN HD, XREC, NO. 6-32 X 0.375 LG | |
| 142 | 471-399 | | SCREW, FLAT HD, 82° SST, NO. 8-32 X 0.625 LG | |
| 143 | 471-336 | | SCREW, FLAT HD, 82°, NO. 8-32 X 0.625 LG | |
| 144 | 471-462 | | SCREW, PAN HD, XREC, NO. 12-24 X 0.75 LG | |
| 145 | 472-578 | | SCREW, OVAL HD, XREC, NKL PLTD, NO. 10-32 X 0.75 LG | |
| 146 | 471-080 | | SCREW, PAN HD, XREC, NO. 8-32 X 0.50 LG | |
| 148 | 493-007 | | NUT, SELF LOCKING, HEX, 8-32 | |
| 149 | 496-007 | | NUT, KEP, NO. 10-32 | |
| 150 | 497-190 | | NUT, SPRING, NO. 10-32 | |
| 151 | 470-637 | | SCREW, CAP HEX, SOC HD, 8-32 X 2.75 LG | |
| 152 | 470-182 | | SCREW, CAP HEX, SOC HD, 8-32 X 2.00 LG | |
| 153 | 501-009 | | WASHER, FLAT, NO. 6 | |
| 154 | 501-011 | | WASHER, FLAT, NO. 10 | |
| 155 | 501-205 | | WASHER, FLAT, NO. 8 | |
| 156 | 501-702 | | WASHER, FINISHING, NYLON, BLK, NO. 10 | |
| 158 | 502-004 | | WASHER, LOCK, SPLIT, NO. 8 | |
| 159 | 502-003 | | WASHER, LOCK, SPLIT, NO. 6 | |
| 160 | 502-005 | | WASHER, LOCK, SPRING, NO. 10 | |
| 162 | 501-008 | | WASHER, PLAIN, NO. 4 | |
| 163 | 496-004 | | NUT, KEP, NO. 4-40 | |
| 164 | 471-078 | | SCREW, PAN HD, XREC, 8-32 X 0.38 LG | |
| 165 | 470-018 | | SCREW, CAP, HEX, SOC HD, 6-32 X 0.375 LG | |
| 166 | 501-188 | | WASHER, PLAIN, SMALL PAT, NO. 6 | |
| 167 | 492-034 | | NUT, HEX, SMALL PAT, NO. 6-32 | |
| 168 | 502-025 | | WASHER, LOCK, SPRING, NO. 6 | |
| 170 | 475-044 | | SCREW, PAN HD, XREC, SEM, 8-32 X 0.38 LG | |
| 171 | 471-067 | | SCREW, PAN HD, XREC, 6-32 X 0.25 LG | |
| 172 | 493-005 | | NUT, HEX, SELF LOCKING, 4-40 | |
| 173 | 470-040 | | SCREW, CAP, HEX, SOC HD, 10-32 X 0.75 LG | |
| 174 | 496-006 | | NUT, KEP, 8-32 | |

S

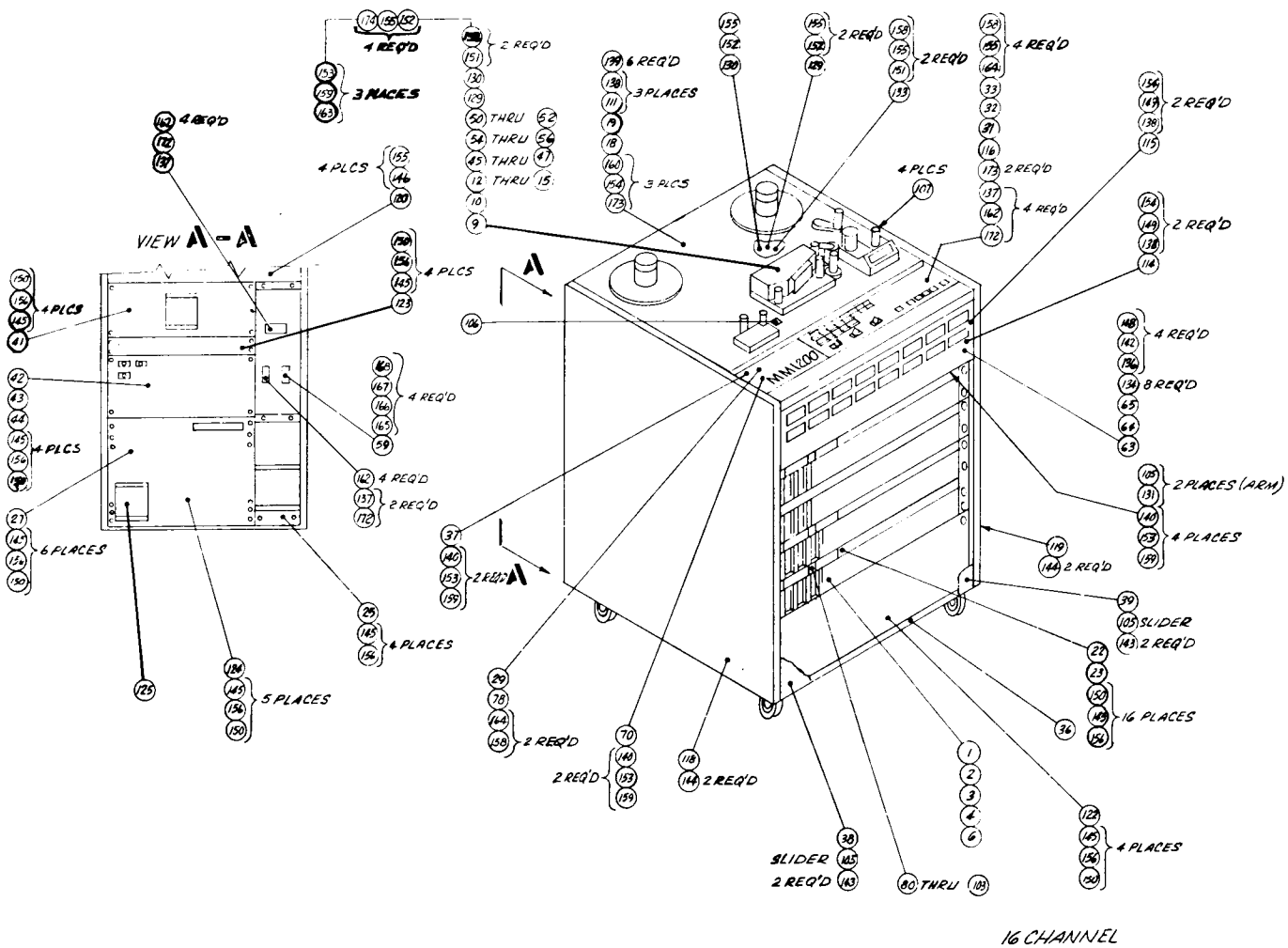

Assembly No. 4010240. MM-1200 Multichannel Recorder/Reproducer Assembly

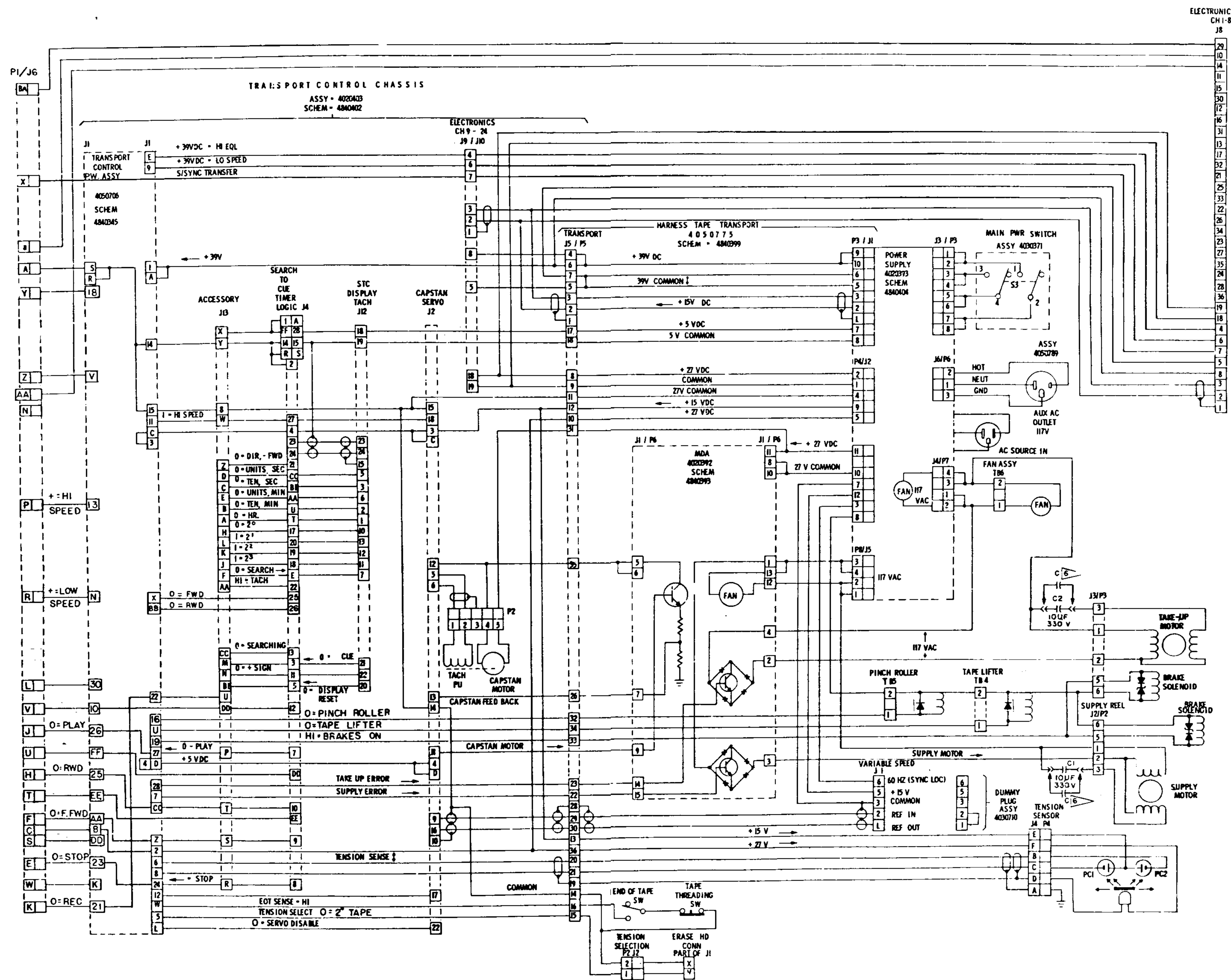

Schematic No. 4840433B.
MM-1200 Multichannel
Recorder/Reproducer Assembly
(Sheet 1 of 3)

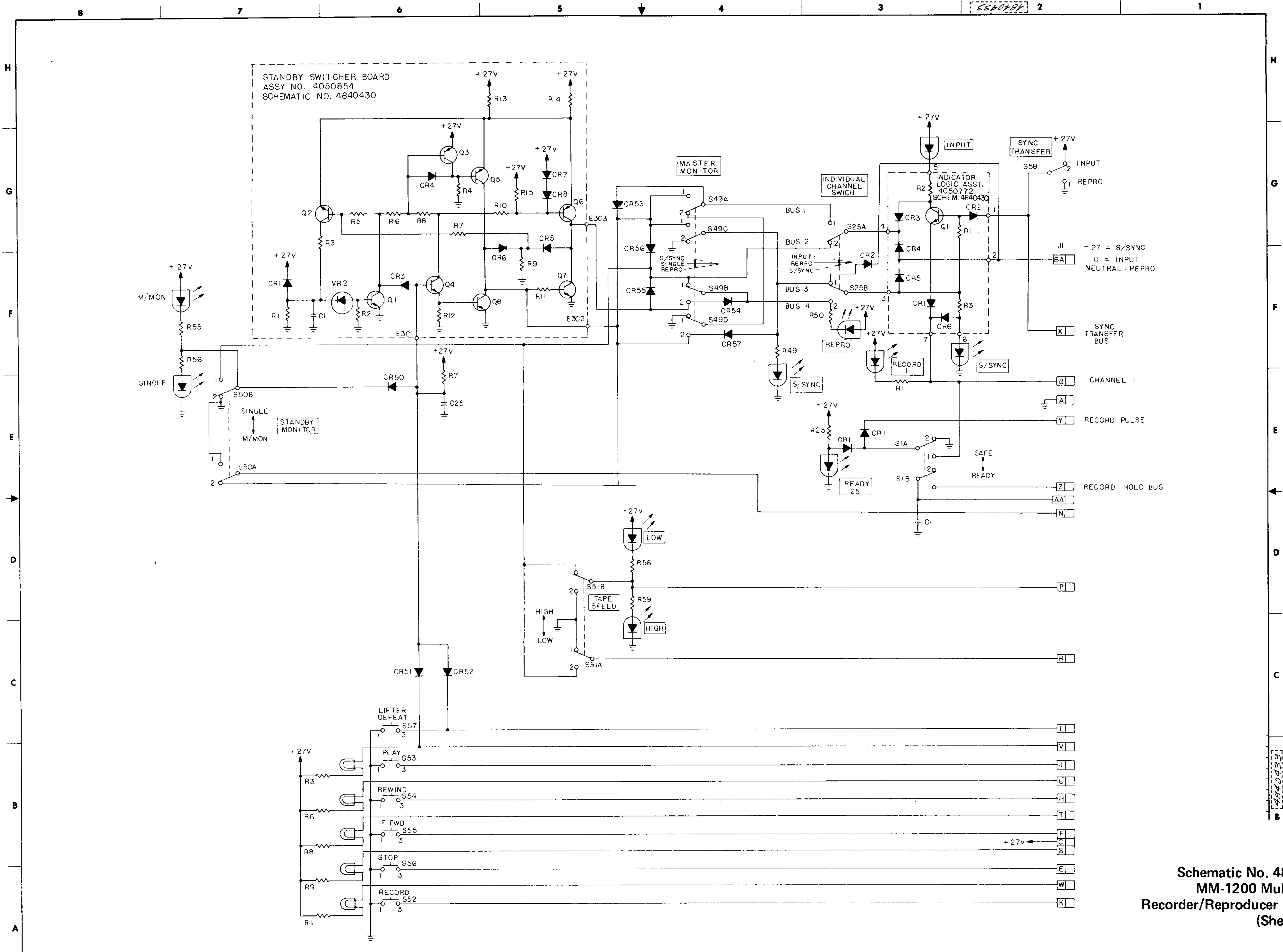

Schematic No. 4840433B.
MM-1200 Multichannel
Recorder/Reproducer Assembly
(Sheet 3 of 3)

| ITEM NO. | AMPEX PART NO. | REFERENCE NUMBER | DESCRIPTION | JEDEC NO. OR MFR. PART NO. |
|----------|----------------|------------------|--------------------------------------------------------------------------------|----------------------------|
| | 4020401-01 | | TRANSPORT ASSEMBLY, 8 CHANNEL, NAB, CCIR/IEC, 15-30 IN/S (NHA 4010240) | |
| | 4020401-02 | | TRANSPORT ASSEMBLY, 16 AND 24 CHANNEL, NAB, CCIR/IEC, 15-30 IN/S (NHA 4010240) | |
| 1 | 4020414-03 | | SEARCH-TO-CUE/TIMER TACHOMETER DISPLAY ASSEMBLY | |
| 2 | 13868-03 | | PLATE, HOUSING, ARM MTG | |
| 3 | 4030328-13 | | CAPSTAN DRIVE ASSEMBLY | |
| 4 | 4030341-02 | | SWITCH AND LATCH BRACKET ASSEMBLY | |
| 6 | 4030413-01 | | CAPSTAN IDLER ASSEMBLY | |
| 7 | 4030375-05 | | REEL MOTOR ASSEMBLY, TAKEUP | |
| 8 | 4030375-06 | | REEL MOTOR ASSEMBLY, SUPPLY | |
| 9 | 4030377-01 | | END-OF-TAPE ARM AND HOUSING ASSEMBLY | |
| 10 | 4030376-01 | | TAPE LIFTER ASSEMBLY | |
| 11 | 4030384-02 | | TENSION SENSOR ASSEMBLY | |
| 12 | 1376517-01 | | TAPE GUIDE IDLER ASSEMBLY, 2 IN, 16,24 CHANNEL | |
| 13 | 4030410-02 | | TAPE GUIDE IDLER ASSEMBLY, 1 IN, 8 CHANNEL | |
| 14 | 4041160-03 | | TOP PLATE AND FRAME ASSEMBLY | |
| 15 | 4041194-02 | | TENSION ARM ASSEMBLY | |
| 16 | 4050775-01 | | TAPE TRANSPORT HARNESS ASSEMBLY | |
| 17 | 4041270-01 | | CAPSTAN IDLER HOUSING ASSEMBLY | |
| 24 | 4220290-01 | | SPACER, IDLER, 2 IN. TAPE GUIDE | |
| 25 | 4250229-01 | | RING, SPACER, SERVO MOTOR | |
| 27 | 4290797-02 | | COVER, TENSION SENSOR | |
| 28 | 4290819-01 | | SHIELD, TRANSPORT | |
| 29 | 4400270-01 | | SCREW, IDLER | |
| 30 | 4605002-10 | | CLAMP, CAPACITOR | |
| 32 | 4952589-04 | | DASHPOT ARM ASSEMBLY | |
| 34 | 1024-01 | | SPRING, TAKEUP TENSION | |
| 35 | 13871-02 | | ARM, SOLENOID | |
| 36 | 50115-04 | | SLEEVE, BUMPER, TAPE TENSION ARM | |
| 37 | 55670-05 | | CAPSTAN SOLENOID ASSEMBLY | |
| 40 | 032-084 | | BOOT, CAPACITOR | |
| 41 | 036-142 | C1,2 | CAPACITOR, FIXED, 10 UF, 330V, 10% | |
| 46 | 302-365 | | STRAP, CABLE | |
| 47 | 470-008 | | SCREW, CAP HD, HEX SOC, 4-40 X 0.25 LG | |
| 48 | 406-030 | | PIN, SPRING, ROLL, 0.125 DIA X 0.625 LG | |
| 49 | 470-017 | | SCREW, CAP, HEX SOC, NO. 8 - 32 X 0.25 LG | |
| 50 | 470-017 | | SCREW, CAP, HEX SOC, NO. 6 - 32 X 0.312 LG | |
| 51 | 470-019 | | SCREW, CAP, HEX SOC, NO. 6 - 32 X 0.44 LG | |
| 52 | 470-021 | | SCREW, CAP, HEX SOC, NO. 6 - 32 X 0.625 LG | |
| 53 | 470-032 | | SCREW, CAP, NO. 8 - 32 X 0.875 LG | |
| 54 | 470-089 | | SCREW, CAP, HEX SOC, NO. 10-32 X 0.50 LG | |
| 55 | 470-124 | | SCREW, CAP, HEX SOC, NO. 8-32 X 1.50 LG | |
| 56 | 470-018 | | SCREW, CAP, HEX SOC, NO. 6-32 X 0.375 LG | |
| 57 | 470-181 | | SCREW, CAP, HEX SOC, NO. 10-24 X 1.50 LG | |
| 58 | 470-022 | | SCREW, CAP, HEX SOC, NO. 6-32 X 0.75 LG | |
| 59 | 471-119 | | SCREW, PAN HD, XREC, NO. 6-32 X 0.37 LG | |
| 61 | 474-052 | | SCREW, SHOULDER, NO. 10-32 X 0.250 LG | |
| 63 | 475-044 | | SCREW, PAN HD, XREC, NO. 8-32 X 0.375 LG | |
| 64 | 477-490 | | SCREW, SET, NO. 4-40 X 0.188 LG | |
| 66 | 496-006 | | NUT, KEP, NO. 8-32 | |
| 69 | 501-009 | | WASHER, FLAT, NO. 6 | |
| 70 | 501-070 | | WASHER, PLAIN, NO. 10 | |
| 71 | 501-188 | | WASHER, PLAIN, SMALL PAT, NO. 6 | |

H

SHEET 1 OF 2

ASSEMBLY NO. 4020401

TITLE: TRANSPORT ASSEMBLY

| ITEM NO. | AMPEX PART NO. | REFERENCE NUMBER | DESCRIPTION | JEDEC NO. OR MFR. PART NO. |
|----------------------------------|----------------------------------------------------------------|------------------|-------------------------------------------------------------------------------------------------------------------------------------------------------|----------------------------|
| 72 74 75 76 78 80 | 501-205 502-003 502-004 502-005 506-013 406-032 | | WASHER, PLAIN, NO. 8 WASHER, LOCK, SPRING, NO. 6 WASHER, LOCK, SPRING, NO. 8 WASHER, LOCK, SPRING, NO. 10 WASHER, "D", NO. 6 PIN, ROLL | |

H

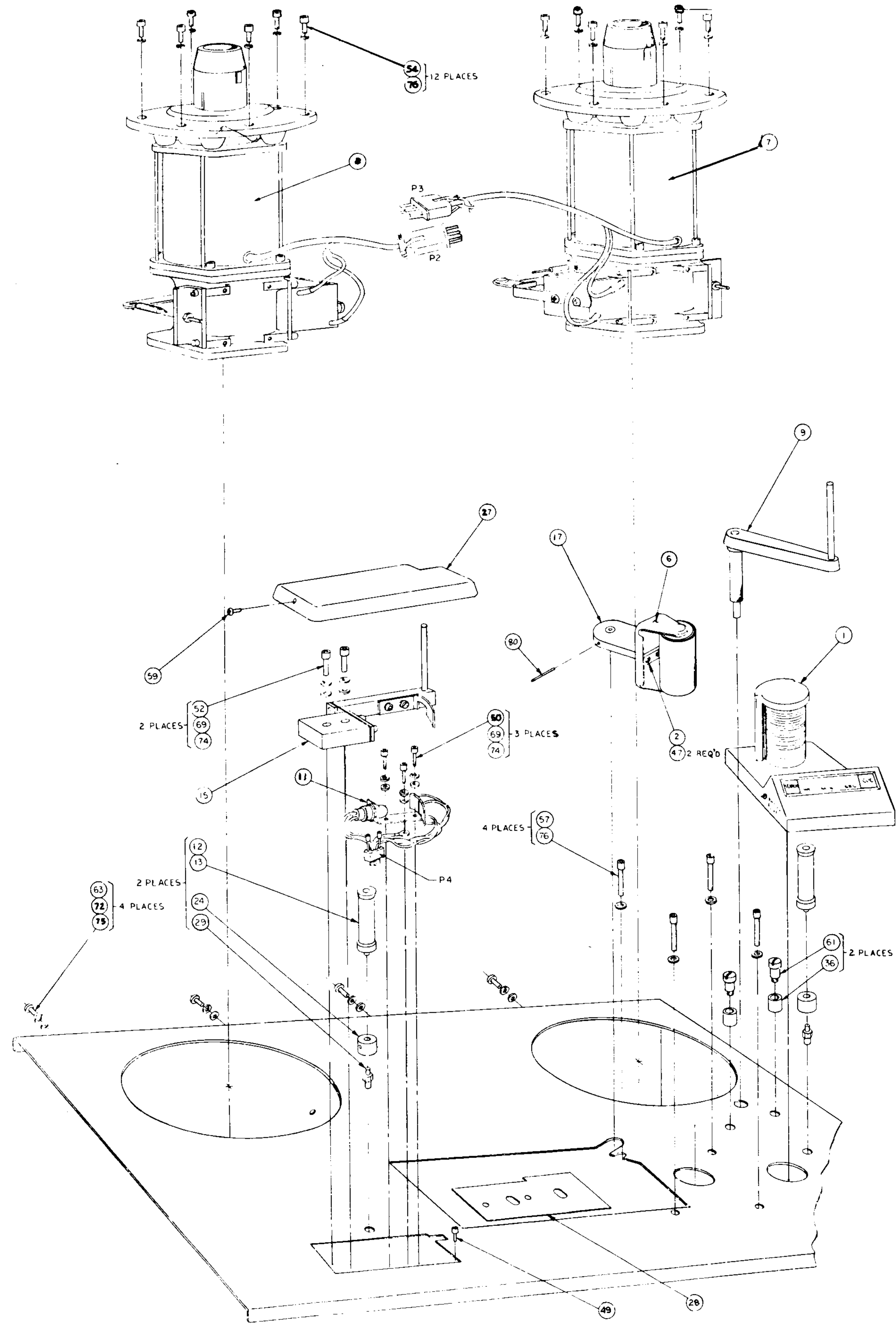

VIEW FROM THE TOP

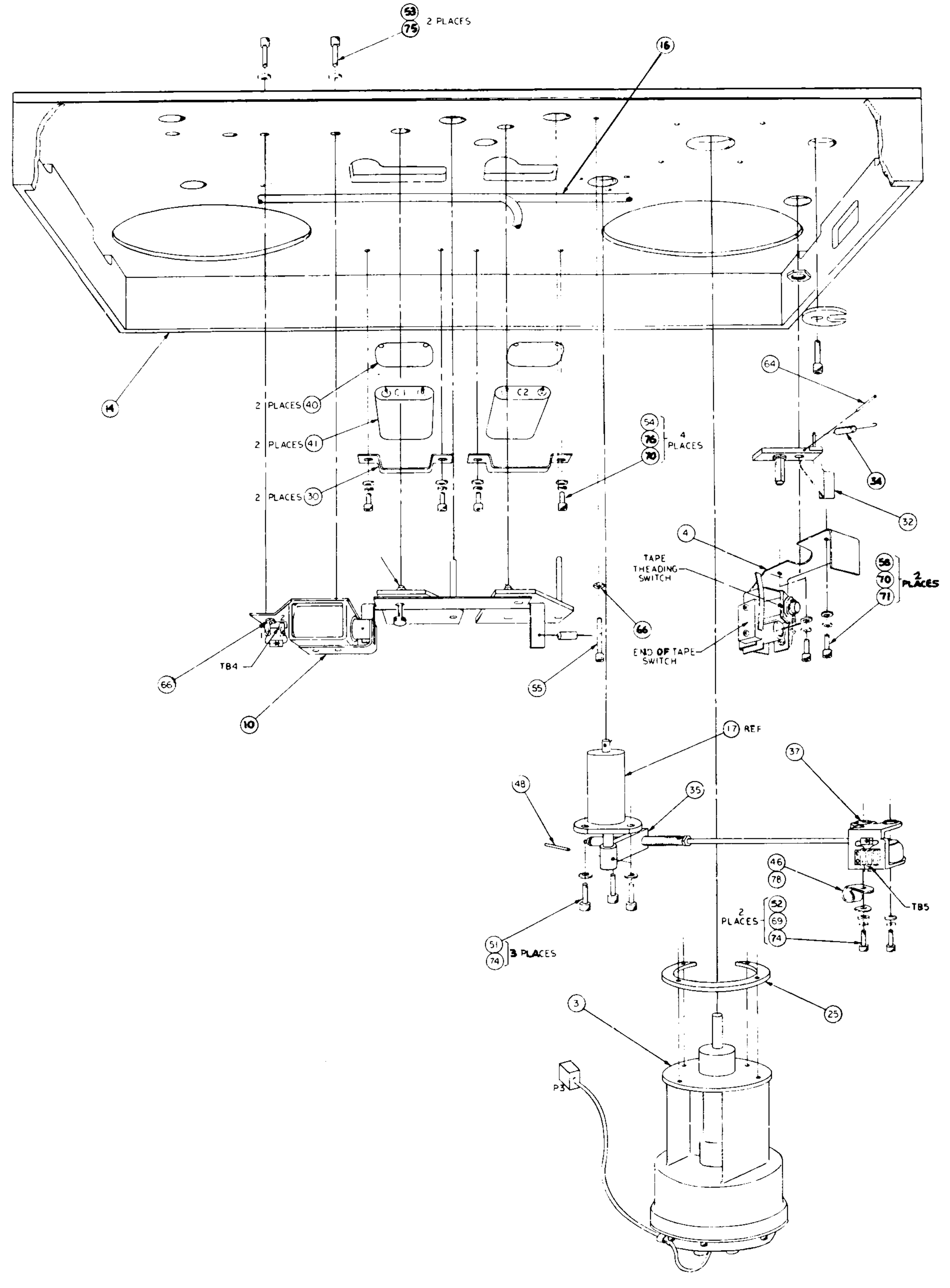

VIEW FROM THE BOTTOM

| ITEM NO. | AMPEX PART NO. | REFERENCE NUMBER | DESCRIPTION | JEDEC NO. OR MFR. PART NO. |
|----------|----------------|------------------|---------------------------------------------------------------|----------------------------|
| | 4020414-03 | | SEARCH-TO-CUE/TIMER TACHOMETER DISPLAY ASSEMBLY (NHA 4020401) | |
| 1 | 4041207-01 | | TAPE TIMER IDLER AND SHAFT ASSEMBLY | |
| 5 | 4110290-02 | | BEZEL, TAPE TIMER | |
| 6 | 4170328-01 | | INSULATOR, PWA | |
| 7 | 4050783-02 | A1 | TACHOMETER PREAMPLIFIER PWA | |
| 8 | 4250089-01 | | DISC, TACH | |
| 9 | 4260529-01 | | BRACKET, SUPPORT, TACH PREAMP | |
| 10 | 4260533-01 | | BRACKET, CABLE | |
| 12 | 4290822-03 | | HOUSING, TACH | |
| 13 | 4290823-02 | | COVER, DUST | |
| 14 | 4290824-01 | | BOSS, MTG | |
| 16 | 4440317-01 | | WASHER, HOLDDOWN | |
| 17 | 4630053-01 | P1 | CONNECTOR, MODIFIED | |
| 18 | 51325-11 | | SHIELD, IDLER | |
| 19 | 119-366 | S3 | SWITCH, PUSHBUTTON | |
| 20 | 4050809-03 | | SEARCH-TO-CUE/TIMER DISPLAY DRIVER PWA | |
| 21 | 4050810-03 | | SEARCH-TO-CUE/TIMER DISPLAY PWA | |
| 22 | 167-366 | | CONTACT, SOC | |
| 24 | 280-890 | | WASHER, SHIM, 0.315 I.D. X 0.500 O.D. X 0.010 THK | |
| 25 | 281-223 | | SPACER, 0.315 I.D. X 0.500 O.D. X 0.016 THK | |
| 26 | 280-362 | | SPACER, UNTHD, PLAIN, NO. 4, 0.25 O.D. X 0.125 LG | |
| 27 | 421-116 | | BEARING, BALL, 0.3150 I.D. X 0.866 O.D. X 0.2756 WIDE | |
| 28 | 430-006 | | RING, RET, EXT | |
| 29 | 430-027 | | RING, RET, INT, 0.961 DIA X 0.042 THK | |
| 32 | 470-014 | | SCREW, CAP, HEX SOC, 4-40 UNC-3A X 0.75 LG | |
| 33 | 470-039 | | SCREW, CAP, HEX SOC, 10-32 UNC-3A X 0.625 LG | |
| 34 | 471-060 | | SCREW, PAN HD, XREC, 4-40 UNC-2A X 0.25 LG | |
| 35 | 471-064 | | SCREW, PAN HD, XREC, 4-40 UNC-2A X 0.50 LG | |
| 36 | 471-061 | | SCREW, PAN HD, XREC, 4-40 UNC-2A X 0.31 LG | |
| 40 | 471-328 | | SCREW, FLT HD, XREC, 4-40 UNC-2A X 0.37 LG | |
| 41 | 471-558 | | SCREW, BIND HD, SLOTTED, 4-40 X 0.19 LG | |
| 43 | 492-008 | | NUT, PLAIN, HEX, NO. 4 | |
| 44 | 498-568 | | NUT, DRESS, 1/4 - 40 | |
| 45 | 501-169 | | WASHER, PLAIN, NO. 4 | |
| 46 | 501-010 | | WASHER, PLAIN, NO. 8 | |
| 47 | 501-576 | | WASHER, SHIM, 0.315 I.D. X 0.500 O.D. X 0.002 THK | |
| 48 | 501-579 | | WASHER, SHIM, 0.315 I.D. X 0.500 O.D. X 0.005 THK | |
| 49 | 501-863 | | WASHER, SHIM, SST, 0.250 I.D. X 0.375 O.D. X 0.032 THK | |
| 50 | 502-002 | | WASHER, LOCK, SPLIT, NO. 4 | |
| 51 | 502-024 | | WASHER, LOCK, INT TOOTH, NO. 4 | |
| 52 | 502-005 | | WASHER, LOCK, SPLIT, NO. 10 | |
| 53 | 502-028 | | WASHER, LOCK, INT TOOTH, NO. 1/4 | |

M

SHEET 1 OF 1

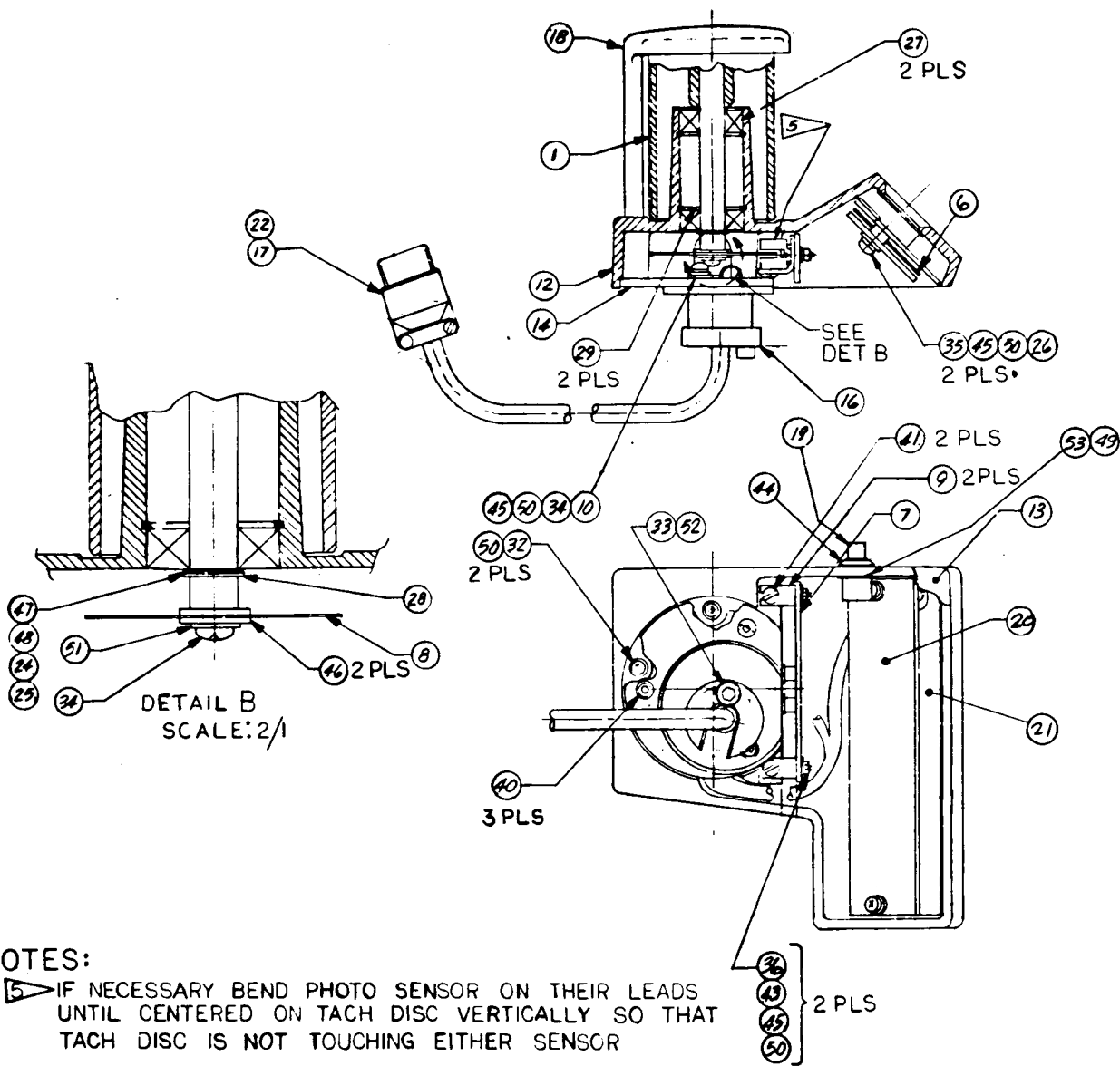

Assembly No. 4020414. Search-to-Cue/Timer Tachometer Display Assembly

| ITEM NO. | AMPEX PART NO. | REFERENCE NUMBER | DESCRIPTION | JEDEC NO. OR MFR. PART NO. |
|-------------|-------------------------------------------------------|------------------|---------------------------------------------------------------------------------------------------|----------------------------|
| 1 2 3 | 4041207-01 1363337-01 4210336-01 430-091 | | TAPE TIMER IDLER AND SHAFT ASSEMBLY (NHA 4020414) IDLER SHAFT RING, RET, EXT, "E" | |

C

| ITEM NO. | AMPEX PART NO. | REFERENCE NUMBER | DESCRIPTION | JEDEC NO. OR MFR. PART NO. |
|----------|----------------|------------------|-----------------------------------------------|----------------------------|
| | 4050810-03 | | SEARCH-TO-CUE/TIMER DISPLAY PWA (NHA 4020414) | |
| 6 | 030-963 | C1 | CAPACITOR, 0.1 UF, 100V, 10% | |
| 11 | 049-520 | R1 | RESISTOR, COMP, 470 OHM, 1/4W, 10% | |
| 12 | 049-520 | R2,3,5,6 | RESISTOR, COMP, 470 OHM, 1/4W, 10% | |
| 13 | 049-545 | R4,7-12 | RESISTOR, COMP, 120 OHM, 1/4W, 10% | |
| 15 | 4620202-AA | S1 | SWITCH, SPST, MOMENTARY, "SEARCH" | |
| 16 | 4620202-AB | S2 | SWITCH, SPST, MOMENTARY, "CUE" | |
| 21 | 581-357 | A2-5 | INTEGRATED CIRCUIT | HP5082-7730 |
| 22 | 581-425 | A1 | INTEGRATED CIRCUIT | HP5082-7732 |
| 25 | 587-544 | A6 | INTEGRATED CIRCUIT | SN7447 |
| 37 | 4840417 | | SCHEMATIC | |

SHEET 1 OF 1

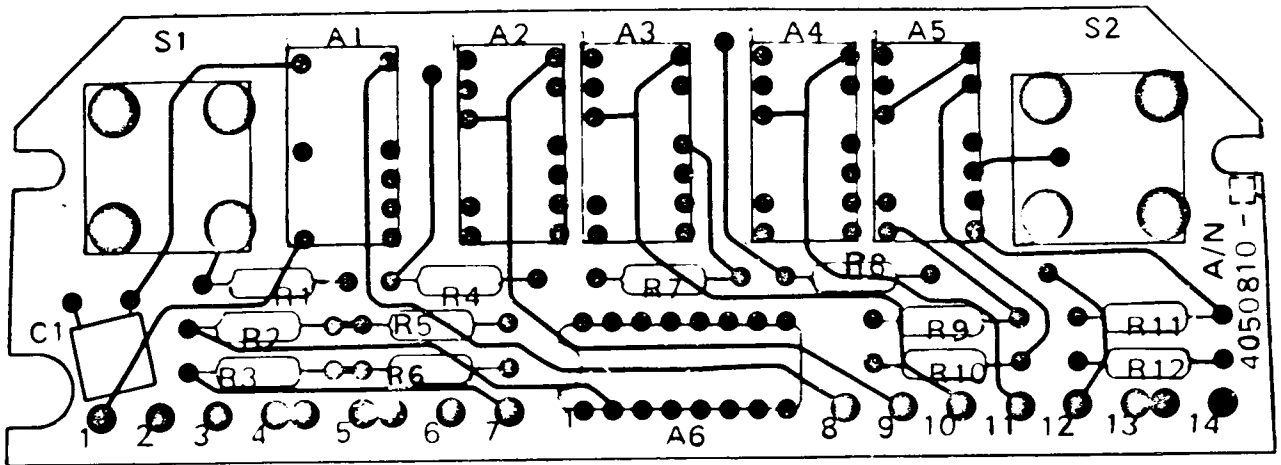

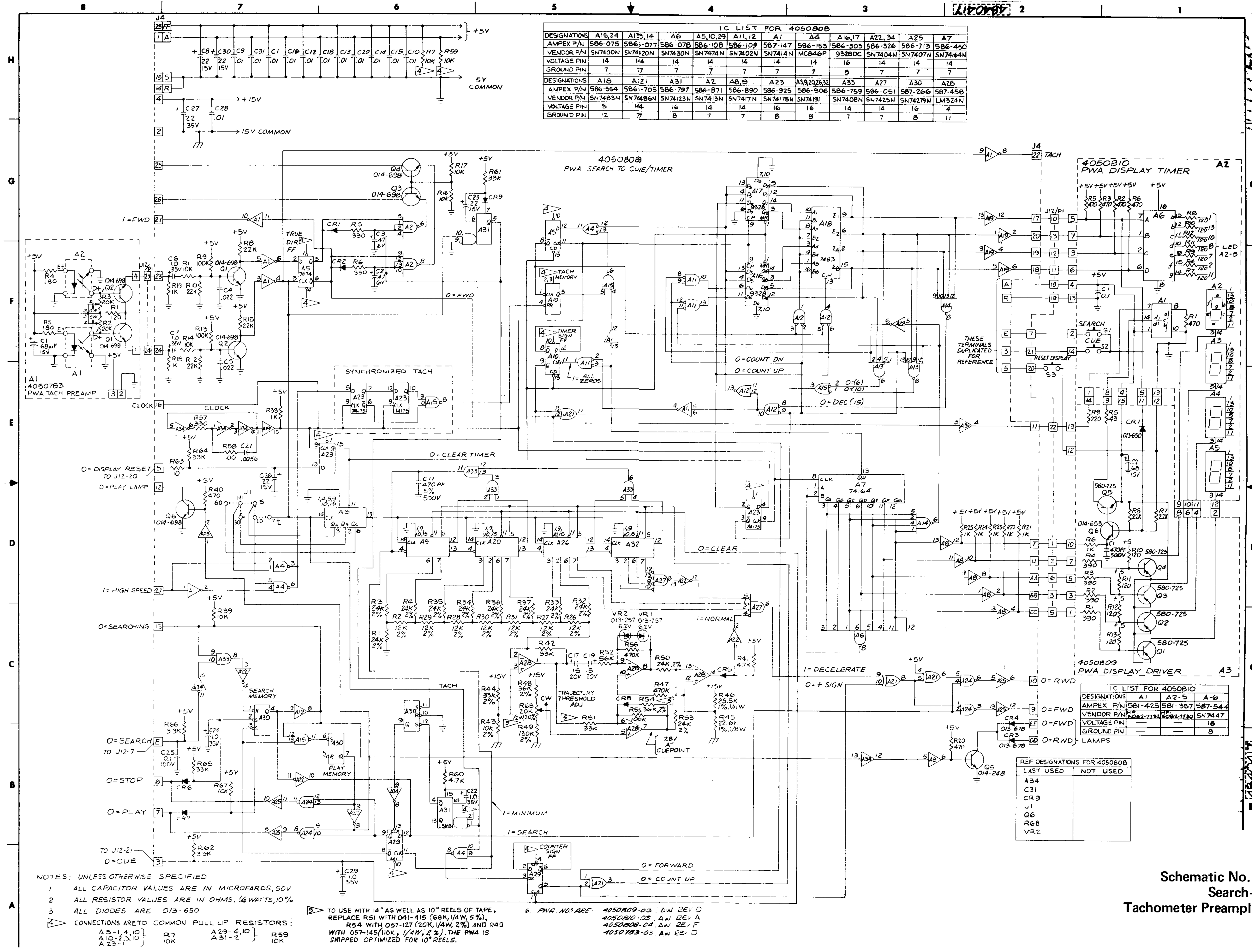

IC LIST FOR 405080B

| DESIGNATIONS | A1,5,24 | A1,5,14 | A6 | A5,10,29 | A11,12 | A1 | A4 | A16,17 | A22,34 | A25 | A7 |
|--------------|---------|---------|---------|----------|---------|---------|---------|---------|---------|---------|----------|
| AMPEX P/N | 586-075 | 586-077 | 586-078 | 586-108 | 586-109 | 586-147 | 586-153 | 586-303 | 586-326 | 586-713 | 586-45C |
| VENDOR P/N | SN7400N | SN7420N | SN7430N | SN7474N | SN7402N | SN7414N | MCM46P | 9328DC | SN7404N | SN7407N | SN74164N |
| VOLTAGE PIN | 14 | 14 | 14 | 14 | 14 | 14 | 14 | 16 | 14 | 14 | 14 |
| GROUND PIN | 7 | 7 | 7 | 7 | 7 | 7 | 7 | 8 | 7 | 7 | 7 |

| DESIGNATIONS | A1,8 | A1,21 | A31 | A2 | A8,19 | A23 | A3,20,26,32 | A53 | A27 | A30 | A28 |
|--------------|---------|---------|----------|---------|---------|----------|-------------|---------|---------|----------|---------|
| AMPEX P/N | 586-554 | 586-705 | 586-797 | 586-871 | 586-890 | 586-925 | 586-906 | 586-759 | 586-051 | 587-266 | 587-45B |
| VENDOR P/N | SN7483N | SN7486N | SN74123N | SN7413N | SN7417N | SN74175N | SN74191 | SN7408N | SN7425N | SN74279N | LM324N |
| VOLTAGE PIN | 5 | 14 | 16 | 14 | 14 | 16 | 14 | 14 | 14 | 16 | 4 |
| GROUND PIN | 12 | 7 | 8 | 7 | 7 | 8 | 8 | 7 | 7 | 8 | 11 |

IC LIST FOR 405081O

| DESIGNATIONS | A1 | A2,5 | A-6 |
|--------------|-----------|-----------|---------|
| AMPEX P/N | 581-425 | 581-357 | 587-544 |
| VENDOR P/N | 5082-7131 | 5082-7130 | SN7447 |
| VOLTAGE PIN | | | 16 |
| GROUND PIN | | | 8 |

REF DESIGNATIONS FOR 405080B

| LAST USED | NOT USED |
|-----------|----------|
| A34 | |
| C31 | |
| CR9 | |
| J1 | |
| Q6 | |
| R68 | |
| VR2 | |

NOTES: UNLESS OTHERWISE SPECIFIED
 1 ALL CAPACITOR VALUES ARE IN MICROFARDS, 50V
 2 ALL RESISTOR VALUES ARE IN OHMS, 1/8 WATTS, 10%
 3 ALL DIODES ARE 013-650
 4 CONNECTIONS ARE TO COMMON PULL UP RESISTORS:
 A5-1,4,10 } R7 A29-4,10 } R59
 A10-2,3,10 } R10 A31-2 } R10K
 A25-1 } R11

5 TO USE WITH 14" AS WELL AS 10" REELS OF TAPE, REPLACE R51 WITH 041-415 (68K, 1/4W, 5%), R54 WITH 057-127 (20K, 1/4W, 2%) AND R49 WITH 057-145 (10K, 1/4W, 2%). THE PWA IS SHIPPED OPTIMIZED FOR 10" REELS.

6. PWA NOS ARE: 4050809-03, ΔW REV D
 4050810-03, ΔW REV A
 4050808-04, ΔW REV F
 4050783-03, ΔW REV D

Schematic No. 4840417J.
 Search-to-Cue and
 Tachometer Pre-amplifier PWA's

| ITEM NO. | AMPEX PART NO. | REFERENCE NUMBER | DESCRIPTION | JEDEC NO. OR MFR. PART NO. |
|----------|----------------|------------------|------------------------------------------------------|----------------------------|
| | 4050809-03 | | SEARCH-TO-CUE/TIMER DISPLAY DRIVER PWA (NHA 4020414) | |
| 7 | 013-650 | CR1 | DIODE | 1N270 |
| 9 | 014-653 | Q6 | TRANSISTOR | 1N3018B |
| 13 | 049-545 | R10-13 | RESISTOR, COMP, 120 OHM, 1/4W, 10% | |
| 14 | 049-517 | R9 | RESISTOR, COMP, 220 OHM, 1/4W, 10% | |
| 15 | 041-639 | R7,8 | RESISTOR, COMP, 2.2K, 1/4W, 10% | |
| 16 | 041-641 | R1-4 | RESISTOR, COMP, 390 OHM, 1/4W, 10% | |
| 17 | 041-692 | R5 | RESISTOR, COMP, 43 OHM, 1/4W, 5% | |
| 18 | 041-979 | R6 | RESISTOR, COMP, 1K, 1/4W, 10% | |
| 20 | 056-291 | C1 | CAPACITOR, MICA, 470 PF, 500V, 5% | |
| 21 | 037-957 | C2 | CAPACITOR, TANT, 68 UF, 15V, 20% | |
| 23 | 580-725 | Q1-5 | TRANSISTOR | MPS6562 |
| 47 | 4840417 | | SCHEMATIC | C |

SHEET 1 OF 1

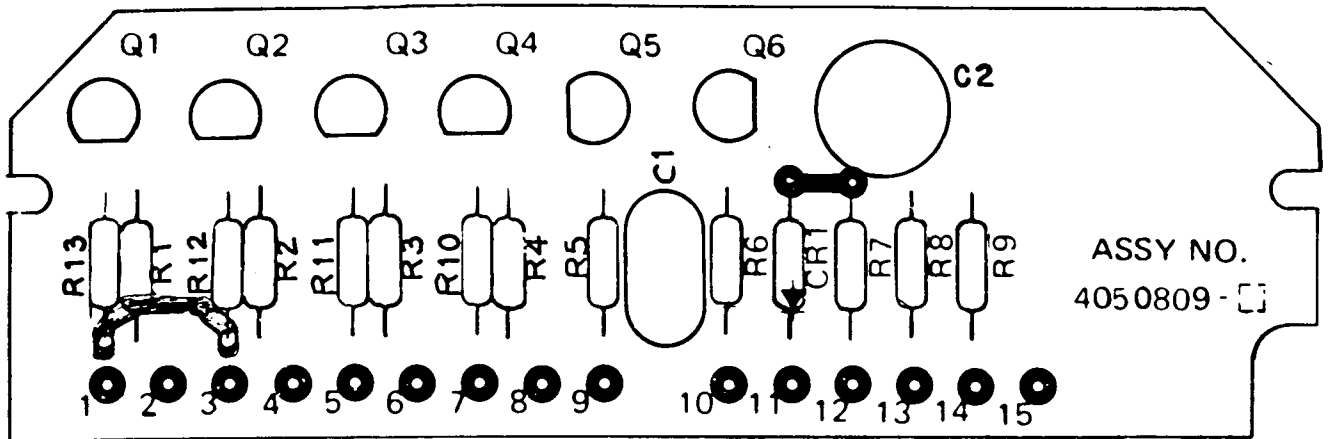

| ITEM NO. | AMPEX PART NO. | REFERENCE NUMBER | DESCRIPTION | JEDEC NO. OR MFR. PART NO. |
|----------|----------------|------------------|-------------------------------------------|----------------------------|
| | 4050783-03 | | TACHOMETER PREAMPLIFIER PWA (NHA 4020414) | |
| 4 | 4840417 | | SCHEMATIC | |
| 6 | 014-698 | Q1,2 | TRANSISTOR | 2N3565 |
| 7 | 058-505 | R2,3 | RESISTOR, VAR, 20K, 1/2W, 10% | |
| 10 | 041-559 | R1 | RESISTOR, COMP, 120 OHM, 1/4W, 5% | |
| 11 | 037-957 | C1 | CAPACITOR, TANT, 68 UF, 15V, 20% | |
| 12 | 4570013-01 | A1,2 | ISOLATOR, OPTICALLY COUPLED | |
| 13 | 103307-01 | | SPACER, 0.25 LG, REF: A1,2 | |
| 14 | 280-130 | | PAD, MTG, TRANS | |
| 15 | 041-739 | R4,5 | RESISTOR, COMP, 180 OHM, 1/4W, 5% | |
| 16 | 267-078 | | INSULATOR, MTG, VERT, REF: R1,4,5 | F |

SHEET 1 OF 1

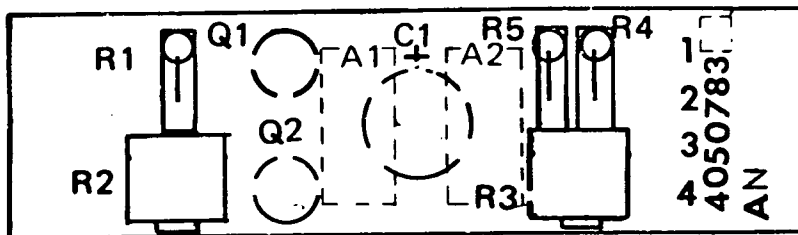
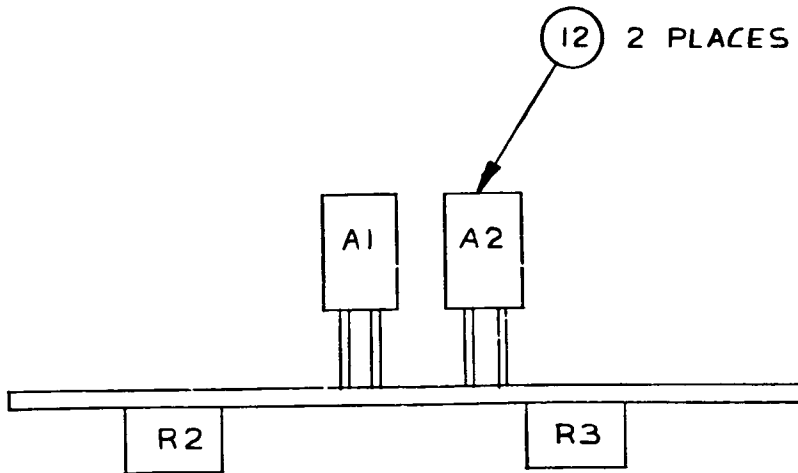

| ITEM NO. | AMPEX PART NO. | REFERENCE NUMBER | DESCRIPTION | JEDEC NO. OR MFR. PART NO. |
|----------|----------------|------------------|--------------------------------------------------------------|----------------------------|
| | 4030328-13 | | CAPSTAN DRIVE ASSEMBLY (NHA 4020401) | |
| 1 | 4030350-01 | | MAGNET AND BRUSH ASSEMBLY | |
| 2 | 4041199-05 | | ROTOR ASSEMBLY | |
| 10 | 4980324-02 | | HOUSING, CAPSTAN DRIVE | |
| 16 | 160-256 | | STOPPER, RUBBER | |
| 20 | 251-010 | | PLUG, BUTTON, 0.375 HOLE | |
| 23 | 302-031 | | CLAMP, CABLE, 0.188 I.D. | |
| 25 | 166-199 | | CONTACT, SOC, 22-24 AWG | |
| 26 | 186-224 | | CONTACT, SOC, 26-24 AWG | |
| 27 | 166-225 | | CONTACT, SOC, 18-16 AWG | |
| 28 | 167-023 | J7 | CONNECTOR, SOC, RECP, 6 POS | |
| 29 | 425-005 | | RING, SEAL, 0.4724 I.D., 0.07 THK | |
| 31 | 470-020 | | SCREW, HEX DR, SOC HD, NO. 6-32 UNC X 0.50 LG | |
| 32 | 470-024 | | SCREW, HEX DR, SOC HD, NO. 6-32 UNC X 1.0 LG | |
| 34 | 471-073 | | SCREW, XREC, PAN HD, NO. 6-32 NC X 0.75 LG | |
| 36 | 471-074 | | SCREW, XREC, PAN HD, NO. 6-32 UNC X 0.88 LG | |
| 37 | 477-509 | | SCREW, SET, HEX DR, CUP POINT, NO. 10-32 UNC X 0.38 LG | |
| 38 | 501-015 | | WASHER, PLAIN, 0.375 O.D., NO. 6 | |
| 39 | 501-763 | | WASHER, BELLEVILLE, 1.248 O.D., 0.043 FREE HT | |
| 40 | 502-003 | | WASHER, LOCK, NO. 6 | |
| 41 | 506-013 | | WASHER, "D" | |
| 42 | 477-347 | | SCREW, SET, HEX SOC, CUP PT, ST, 6-32 X 0.38 LG | |
| 43 | 477-507 | | SCREW, SET, HEX SOC, CUP PT, CRES, 10-32 X 0.250 LG | |
| 45 | 4030330-03 | | TACHOMETER WHEEL ASSEMBLY | |
| 49 | 4030332-03 | | CAPSTAN DRIVE ASSEMBLY, COIL SUPPORT AND PICKUP | |
| 50 | 4220254-02 | | PLATE, MAGNET RETURN | |
| 54 | 4100188-05 | | CAP, CAPSTAN DRIVE | |
| 55 | 4200071-03 | | BEARING, BALL, ANGULAR CONTACT, 0.6693 I.D., 1.5748 O.D. | |
| 56 | 4200070-03 | | BEARING, BALL, ANGULAR CONTACT, 0.47241 I.D., 1.2598 O.D. | |
| 58 | 4210329-10 | | SHAFT, CAPSTAN DRIVE | |
| 59 | 4600084-01 | | SHIELD, BEARING | |
| 60 | 250-195 | | BUMPER | |

Y

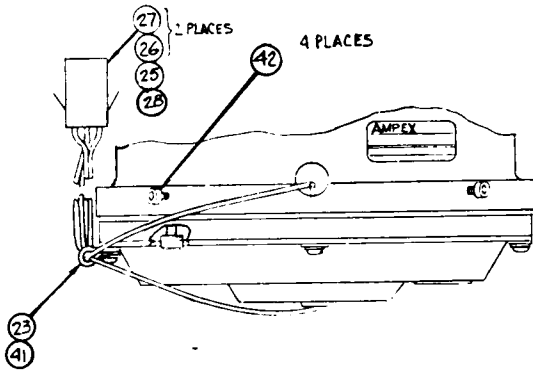

WIRING DIAGRAM ITEM 28

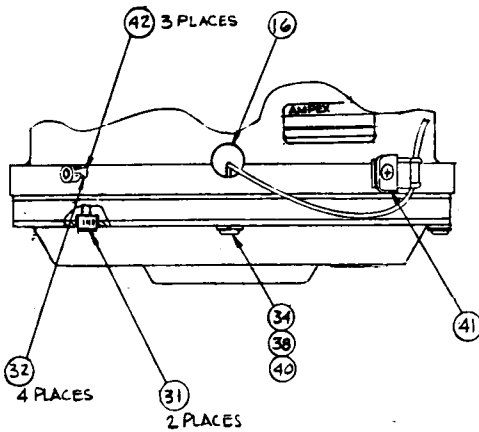
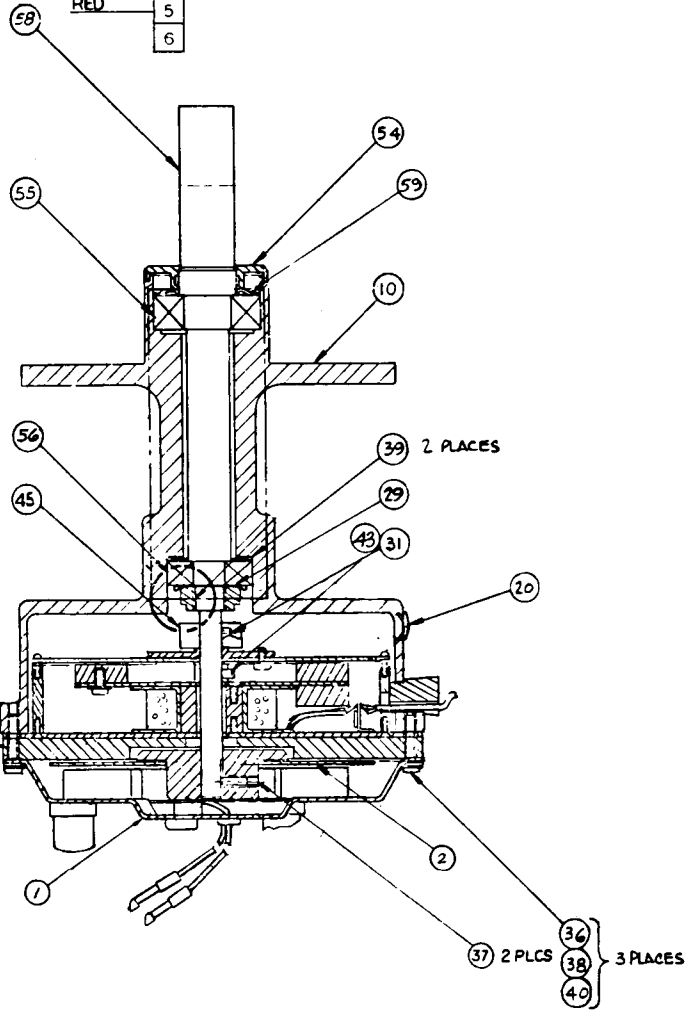
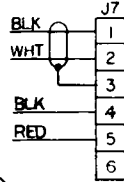

Assembly No. 4030328. Capstan Drive Assembly

| ITEM NO. | AMPEX PART NO. | REFERENCE NUMBER | DESCRIPTION | JEDEC NO. OR MFR. PART NO. |
|----------|----------------|------------------|--------------------------------------------------------------|----------------------------|
| | 4030332-04 | | CAPSTAN DRIVE COIL SUPPORT AND PICKUP ASSEMBLY (NHA 4030328) | |
| 1 | 4030329-01 | | COIL ASSEMBLY | |
| 5 | 4030331-02 | | TACKOMETER PICKUP ASSEMBLY | |
| 7 | 180-793 | | TERMINAL STRIP, SOLDER LUG, MINIATURE | |
| 9 | 4220253-02 | | SPACER, MAGNET DISC | |
| 12 | 492-007 | | NUT, PLAIN, HEX, NO. 2-56 | |
| 13 | 501-155 | | WASHER, PLAIN, NO. 2 | |
| 14 | 470-008 | | SCREW, CAP, HEX SOC, 4-40 UNC X 0.25 LG | |
| 15 | 471-324 | | SCREW, FLAT HD, XREC, 4-40 UNC X 0.25 LG | |
| 21 | 4041124-04 | | MAGNET DISC ASSY | D |

SHEET 1 OF 1

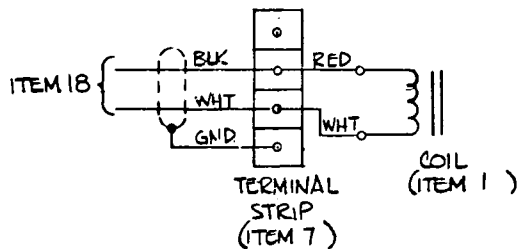
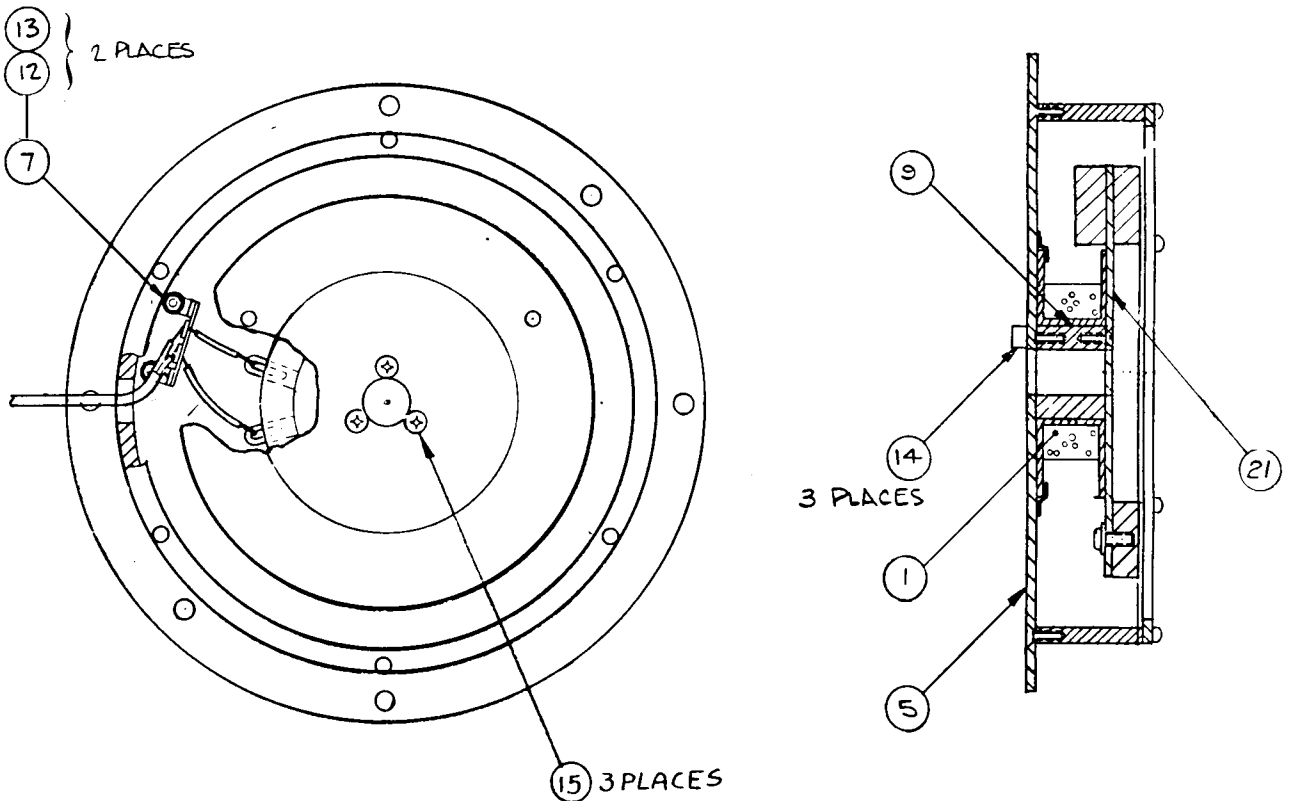

| ITEM NO. | AMPEX PART NO. | REFERENCE NUMBER | DESCRIPTION | JEDEC NO. OR MFR. PART NO. |
|----------|----------------|------------------|-------------------------------------------------|----------------------------|
| | 4030341-02 | | SWITCH AND LATCH BRACKET ASSEMBLY (NHA 4020401) | |
| 1 | 4260448-01 | | BRACKET, MAGNETIC LATCH | |
| 2 | 4590032-01 | | DASHPOT | |
| 3 | 4952557-02 | | BRACKET, MTG, DASHPOT | |
| 5 | 51271-01 | S2 | BRACKET | |
| 7 | 120-074 | | SWITCH, PUSHBUTTON | |
| 8 | 120-062 | S1 | SWITCH, LEVER | |
| 11 | 311-069 | | CATCH ASSEMBLY, MAGNETIC | |
| 14 | 471-071 | | SCREW, PAN HD, XREC, 6-32 X 0.50 LG | |
| 17 | 471-153 | | SCREW, PAN HD, XREC, NO. 6-32 X 1.25 LG | |
| 19 | 496-005 | | NUT, KEP, 6-37 | |
| 21 | 501-009 | | WASHER, FLAT, NO. 6 | |
| 22 | 501-021 | | WASHER, FLAT, 0.016 THK, NO. 6 | |
| 25 | 171-008 | | TERMINAL, QUICK DISCONNECT, KNIFE | |

C

SHEET 1 OF 1

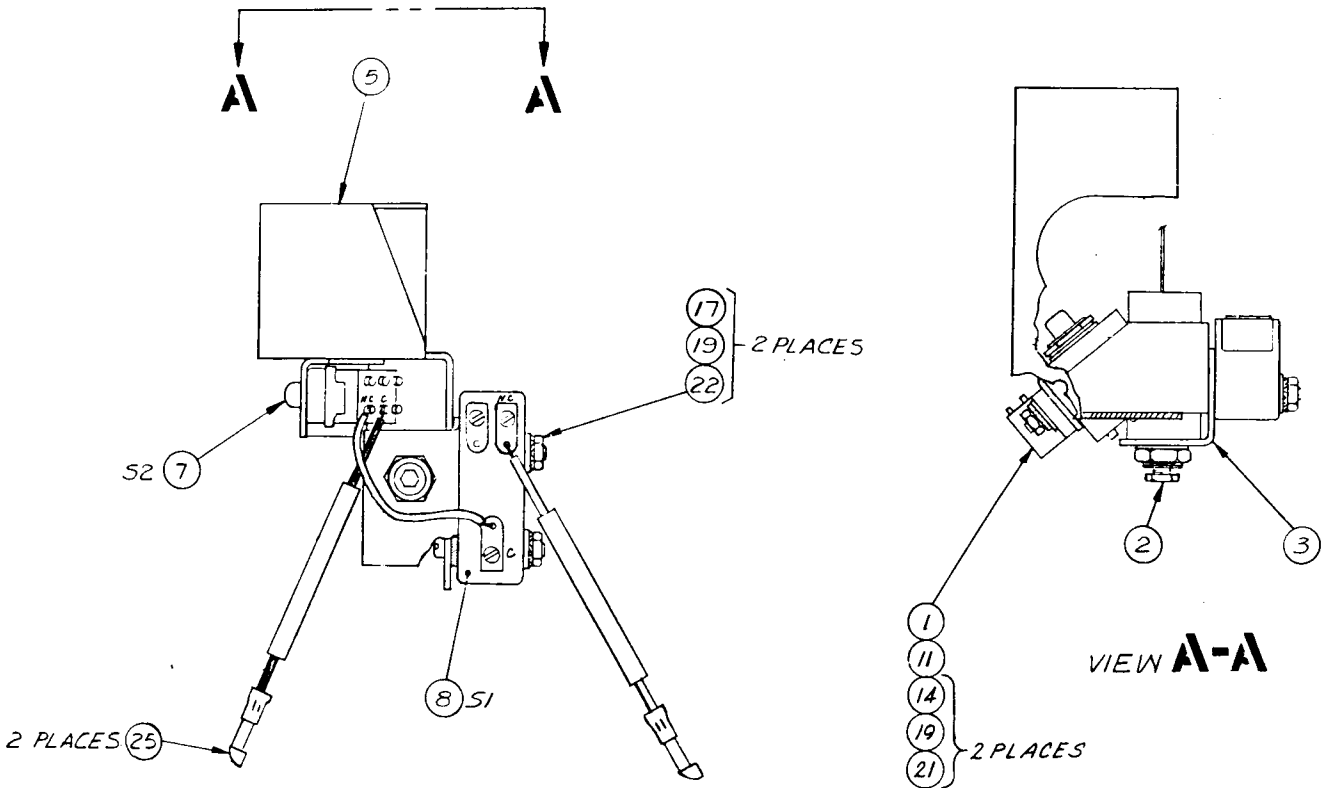

| ITEM NO. | AMPEX PART NO. | REFERENCE NUMBER | DESCRIPTION | JEDEC NO. OR MFR. PART NO. |
|----------|----------------|------------------|----------------------------------------------|----------------------------|
| | 4041270-01 | | CAPSTAN IDLER HOUSING ASSEMBLY (NHA 4020401) | |
| 1 | 14563-01 | | HOUSING, SHAFT, CAPSTAN IDLER | |
| 2 | 164834-02 | | BEARING, BALL | |
| 3 | 4030372-01 | | CAPSTAN IDLER ARM ASSEMBLY | |
| 4 | 430-006 | | RING, RET | |
| 5 | 501-022 | | WASHER, 0.328 I.D, 0.562 O.D., 0.032 THK | |
| 6 | 501-932 | | WASHER, WAVY, 0.346 I.E. X 0.005 THK | |

SHEET 1 OF 1

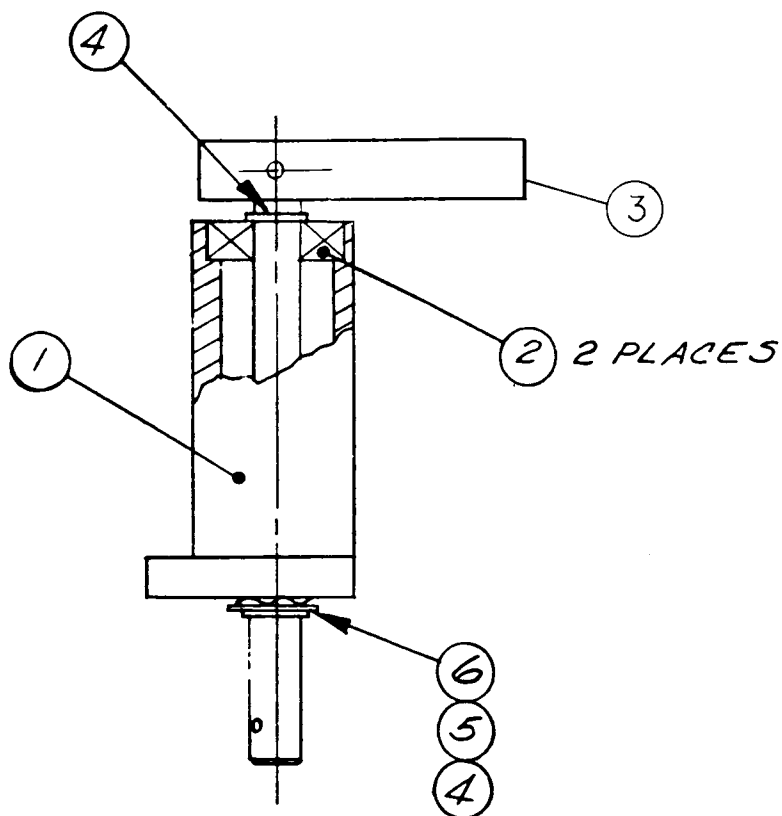

| ITEM NO. | AMPEX PART NO. | REFERENCE NUMBER | DESCRIPTION | JEDEC NO. OR MFR. PART NO. |
|----------|----------------|------------------|------------------------------------------|----------------------------|
| 1 | 4030372-01 | | CAPSTAN IDLER ARM ASSEMBLY (NHA 4041270) | |
| 2 | 4210368-02 | | SHAFT, CAPSTAN IDLER | |
| 4 | 4230262-02 | | HOUSING, ARM, CAPSTAN IDLER | |
| | 406-032 | | PIN, ROLL, 0.125 DIA X 1.00 LG | A |

SHEET 1 OF 1

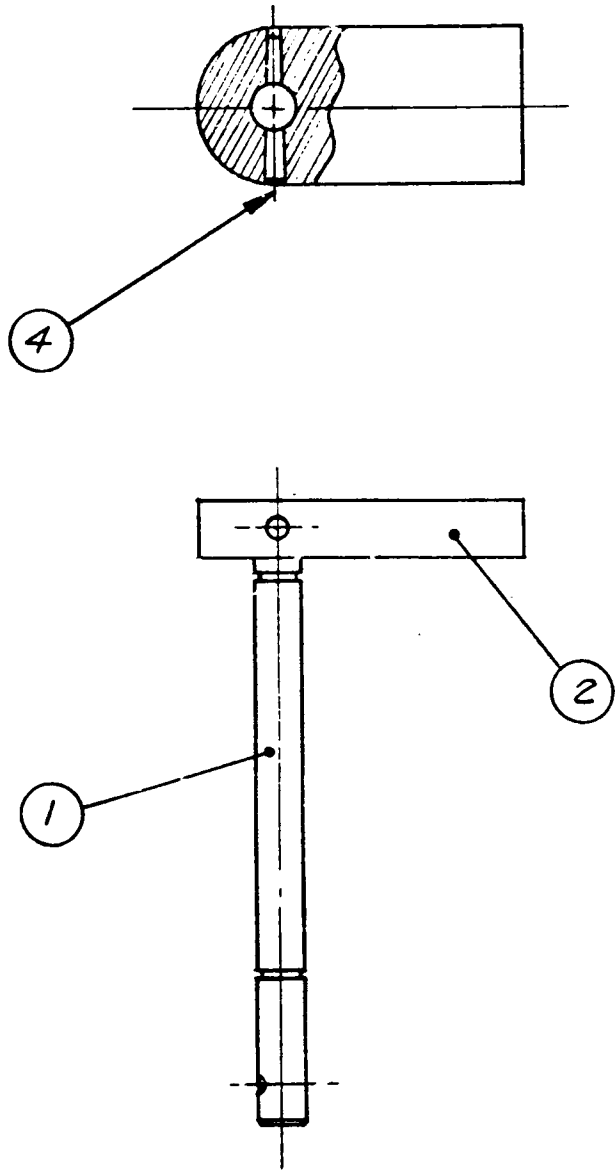

| ITEM NO. | AMPEX PART NO. | REFERENCE NUMBER | DESCRIPTION | JEDEC NO. OR MFR. PART NO. |
|----------|--------------------------|------------------|----------------------------------------------------------------------------------------|----------------------------|
| | 4030375-07 4030375-08 | | REEL MOTOR ASSEMBLY, TAKEUP (NHA 4020401) REEL MOTOR ASSEMBLY, SUPPLY (NHA 4020401) | |
| 3 | 13958-01 | | PLATE, BRAKE SPRING | |
| 4 | 13959-02 | | LEVER, BRAKE SPRING | |
| 6 | 13966-02 | | DRUM, BRAKE | |
| 7 | 13968-01 | | LINK, SOLENOID | |
| 8 | 14331-01 | | BRAKE BAND ASSEMBLY | |
| 9 | 14349-01 | | MOTOR, TORQUE | |
| 10 | 14418-08 | | HOUSING, BRAKE | |
| 11 | 14585-04 | | STOP, SOLENOID | |
| 12 | 50630-01 | | PIN, SHORT, BRAKE LOOP | |
| 13 | 50630-02 | | PIN, LONG, BRAKE LOOP | |
| 15 | 52172-01 | | SPRING, BRAKE, ADJ | |
| 16 | 52173-01 | | PIN, LINK, LEFT | |
| 17 | 52173-02 | | PIN, LINK, RIGHT | |
| 18 | 52174-01 | | BOLT, EYE | |
| 19 | 4220283-01 | | FLANGE, MTG, REEL | |
| 20 | 145-012 | | CONNECTOR, 6 PIN, LOCKING, MALE | |
| 21 | 302-007 | | CLAMP, CABLE, PLASTIC, 1/4 I.D. | |
| 22 | 400-009 | | PIN, CLEVIS, 1/8 DIA X 17/32 LG | |
| 23 | 401-007 | | PIN, COTTER, 1/16 DIA X 1/2 LG | |
| 24 | 406-012 | | PIN, ROLL, 0.094 DIA X 1.0 LG | |
| 25 | 430-004 | | RING, RET | |
| 26 | 470-029 | | SCREW, CAP, NO. 8-32 X 1/2 LG | |
| 27 | 171-009 | | CONNECTOR, SOLDERLESS, KNIFE | |
| 28 | 470-039 | | SCREW, CAP, NO. 10-32 X 5/8 LG | |
| 29 | 475-038 | | SCREW, SEM, NO. 8-32 X 5/16 LG | |
| 30 | 477-067 | | SCREW, SET, NO. 8-32 X 1/4 LG | |
| 31 | 493-008 | | NUT, SELF LOCK, NO. 10-32 | |
| 32 | 493-009 | | NUT, SELF LOCK, NO. 6-32 | |
| 33 | 501-010 | | WASHER, FLAT, NO. 8 | |
| 34 | 502-005 | | WASHER, LOCK, SPRING, NO. 10 | |
| 35 | 470-040 | | SCREW, CAP, NO. 10-32 X 3/4 LG | |
| 36 | 502-004 | | WASHER, LOCK, SPRING, NO. 8 | |
| 37 | 1360126-04 | | KNOB, TURNTABLE ASSEMBLY | |
| 43 | 013-678 | CR1 | DIODE | 1N4005 |
| 50 | 506-016 | | WASHER, "D", NO. 8 | |
| 51 | 302-365 | | TY WRAP | |
| 52 | 502-026 | | WASHER, LOCK, NO. 8 | |
| 54 | 13964-02 | | PAD, TURNTABLE | |
| 64 | 4030417-01 | | REEL MOTOR SOLENOID ASSEMBLY | |
| 66 | 581-156 | CR2 | DIODE | 1N4750A |

G

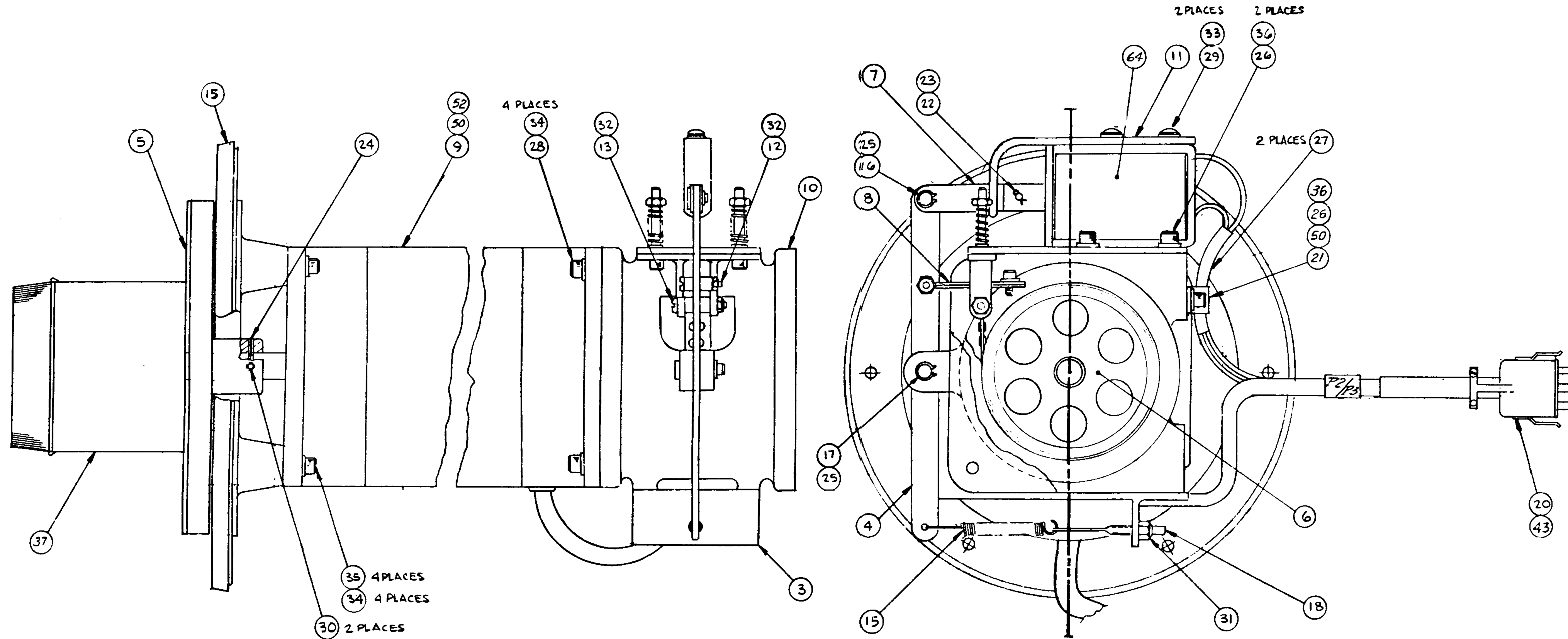

-07 SHOWN
 (-08 BRAKE ASSY REVERSED)

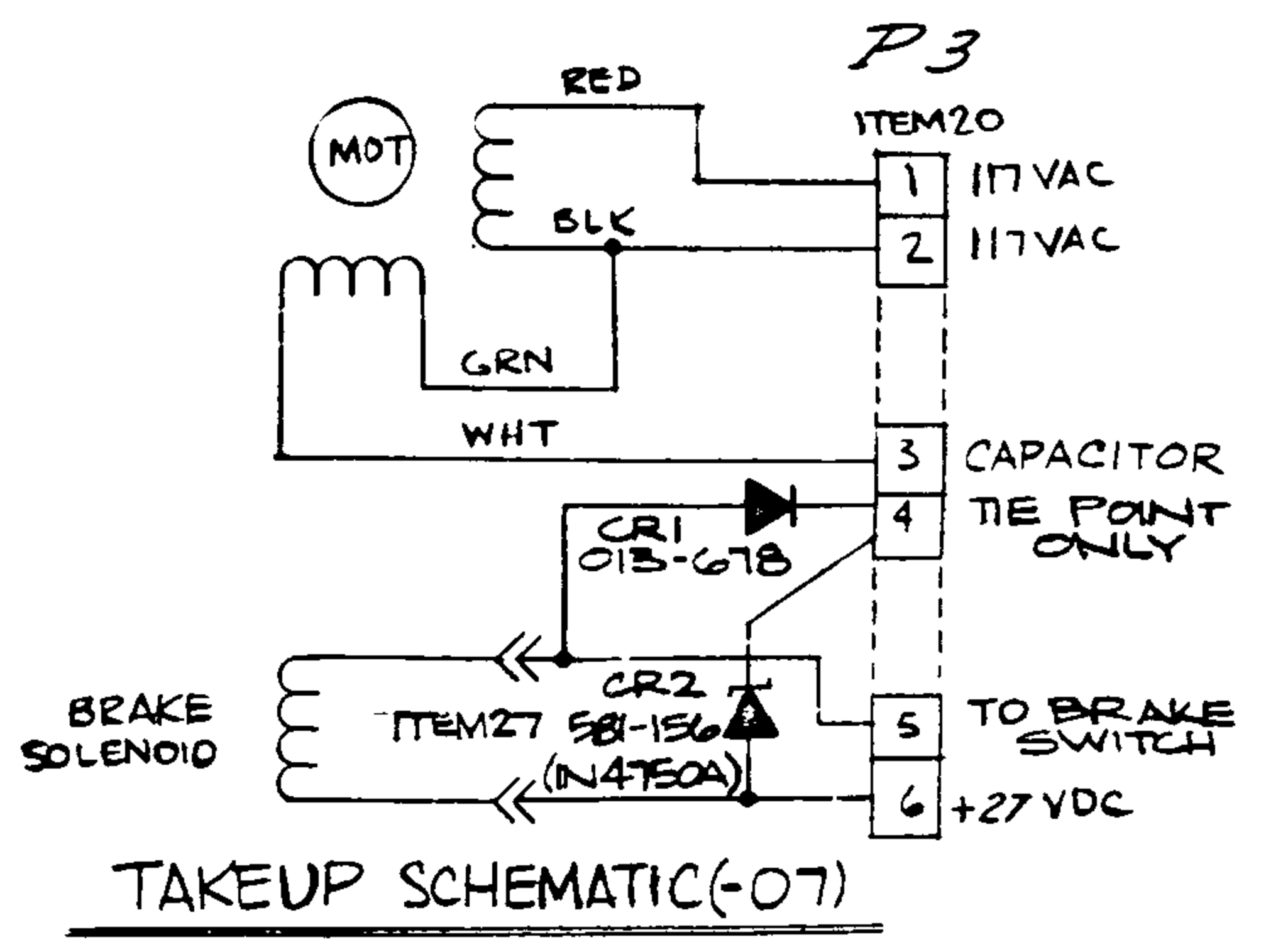
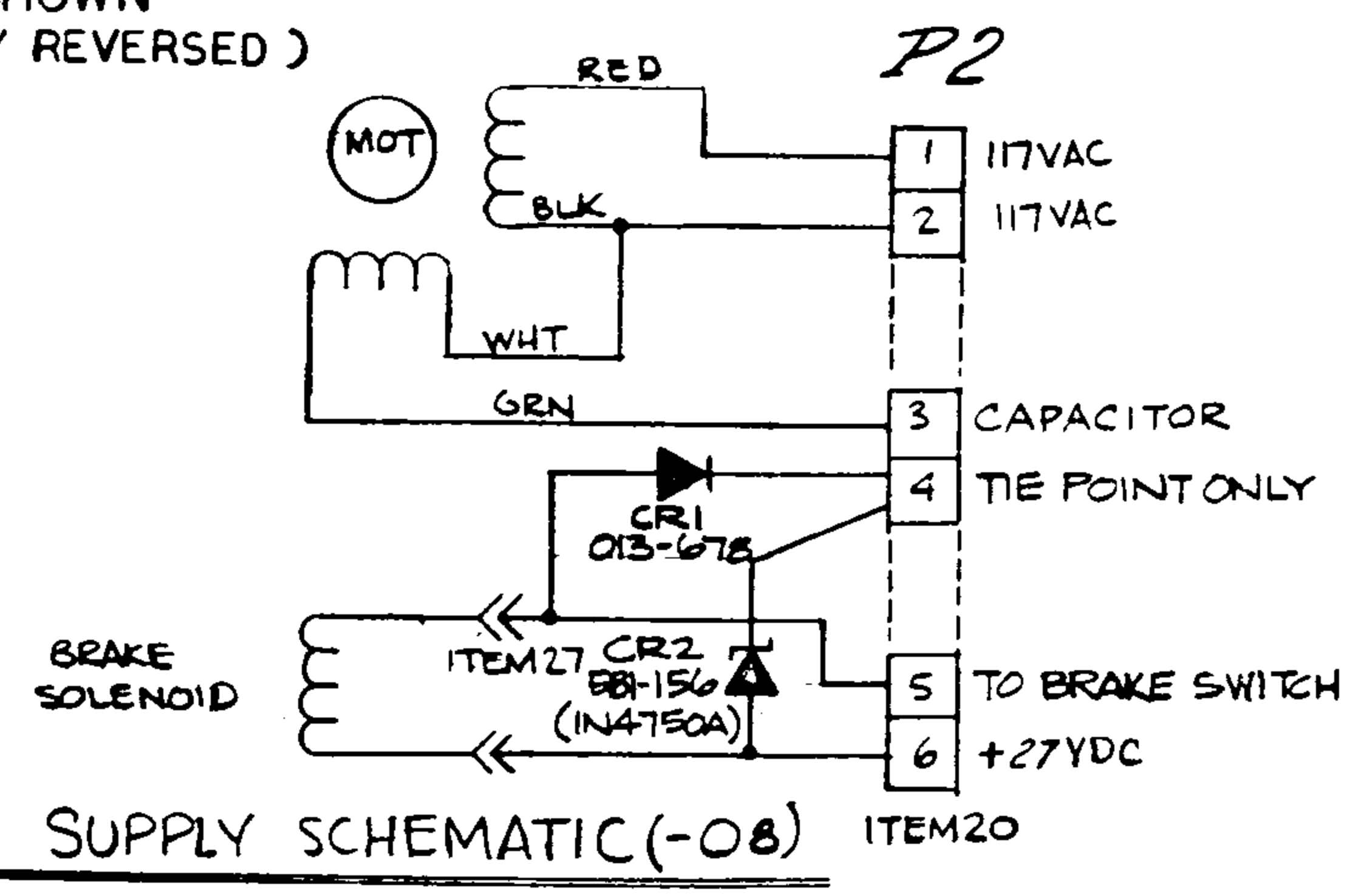

Assembly No. 4030375.
 Reel Motor Assembly,
 Takeup and Supply

| ITEM NO. | AMPEX PART NO. | REFERENCE NUMBER | DESCRIPTION | JEDEC NO. OR MFR. PART NO. |
|----------|----------------|------------------|--------------------------------------------|----------------------------|
| | 4030417-01 | | REEL MOTOR SOLENOID ASSEMBLY (NHA 4030375) | |
| 1 | 13817-01 | | SPRING | |
| 2 | 13955-01 | | BRACKET, BRAKE LIMIT | |
| 3 | 13957-02 | | PLATE, BASE, SOLENOID | |
| 4 | 470-124 | | SCREW, CAP, 8-32 X 1.50 LG | |
| 5 | 475-038 | | SCREW, SEM, 8-32 X 0.312 LG | |
| 6 | 493-007 | | NUT, SELF LOCKING, 8-32 | |
| 7 | 501-010 | | WASHER, FLAT, NO. 8 | |
| 8 | 4030418-01 | | SOLENOID ASSEMBLY | |
| 10 | 171-009 | | CONNECTOR, SOLDERLESS | A |

SHEET 1 OF 1

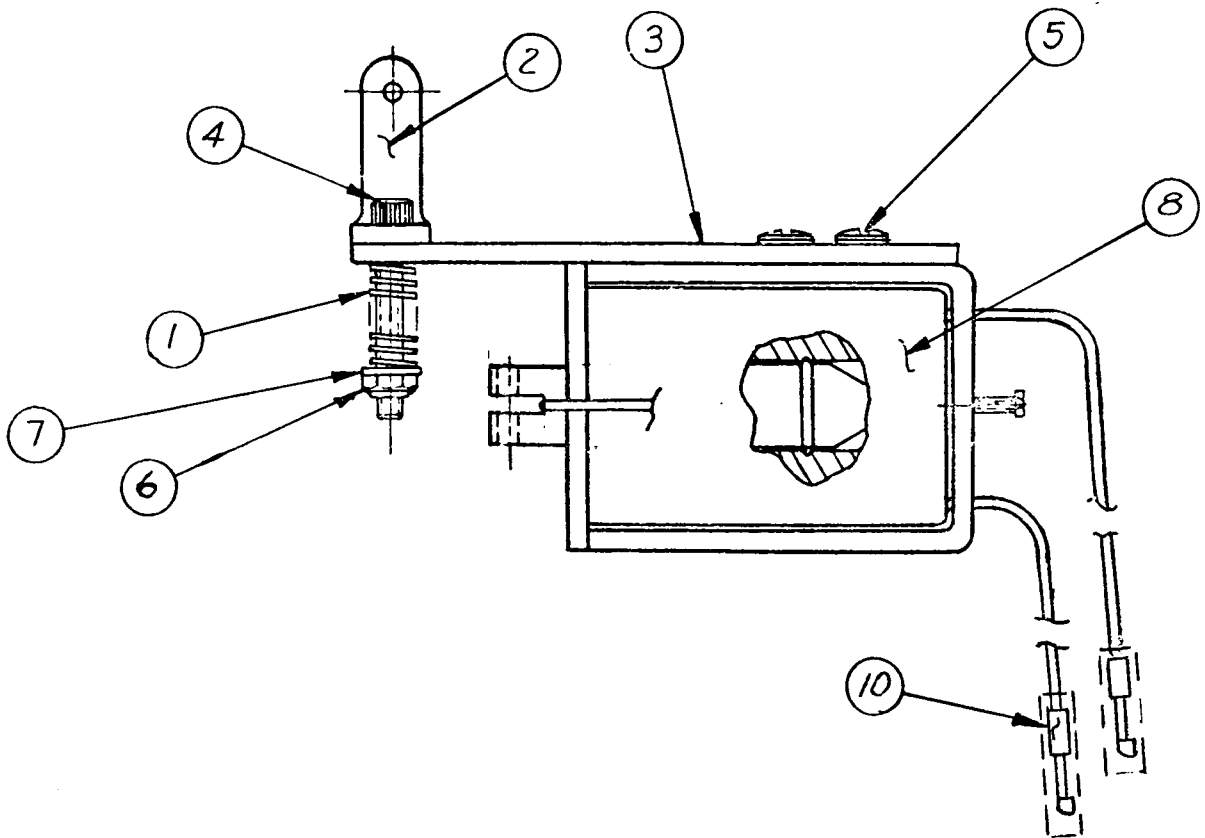

| ITEM NO. | AMPEX PART NO. | REFERENCE NUMBER | DESCRIPTION | JEDEC NO. OR MFR. PART NO. |
|----------|----------------|------------------|---------------------------------------------------------------------------------------|----------------------------|
| 1 | 4030418-01 | | SOLENOID ASSEMBLY (NHA 4030417) | |
| 2 | 4590083-01 | | SOLENOID, REEL MOTOR AND TAPE LIFTER SCREW, LOCKING, CAP, HEX SOC, 4-40 X 0.38 O-RING | A |
| 3 | 470-625 | | | |
| | 4310023-01 | | | |

SHEET 1 OF 1

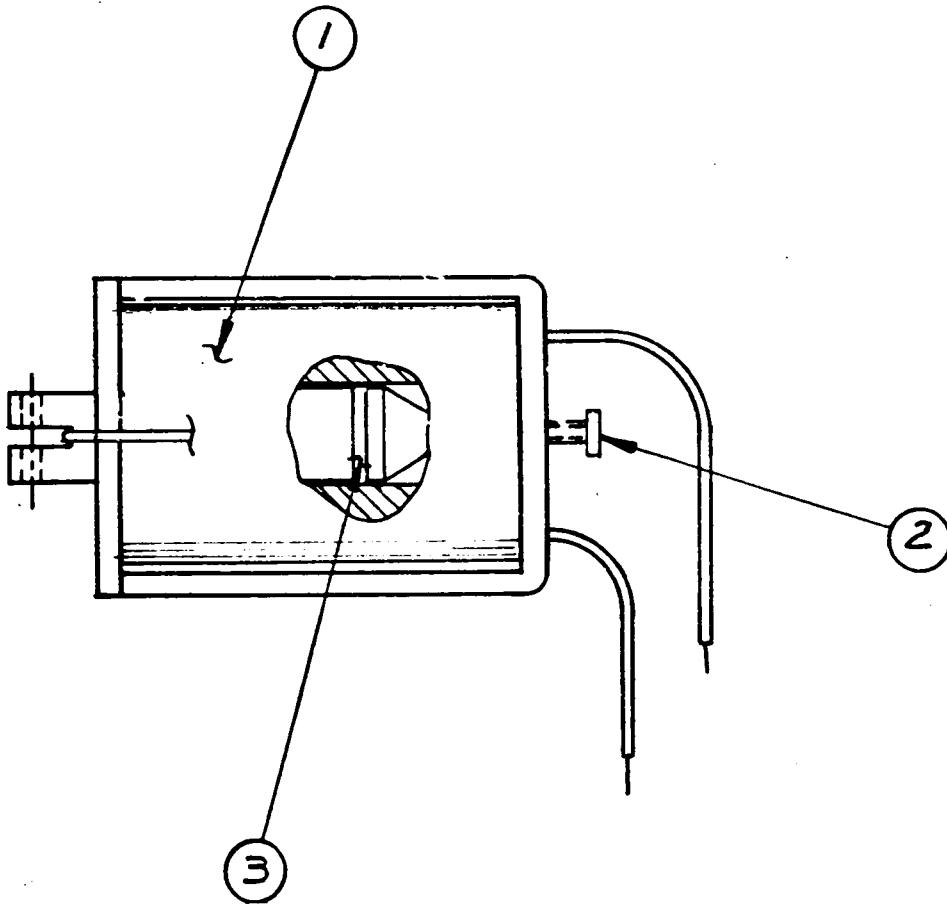

| ITEM NO. | AMPEX PART NO. | REFERENCE NUMBER | DESCRIPTION | JEDEC NO. OR MFR. PART NO. |
|----------|----------------|------------------|----------------------------------------------------------|----------------------------|
| | 4030377-01 | | END-OF-TAPE ARM AND HOUSING ASSEMBLY (NHA 4010240) | |
| 1 | 51101-01 | | TAPE TENSION ARM HOUSING ASSY | |
| 4 | 4041163-02 | | TENSION ARM ASSY | |
| 10 | 430-006 | | RING, RET | |
| 11 | 498-018 | | NUT, HEX, 3/4 - 16 | |
| 15 | 501-888 | | WASHER, PLAIN, 0.316 I.D. X 0.047 THK | |
| 16 | 501-932 | | WASHER, WAVY, 0.346 I.D. X 0.005 THK X 0.080 FREE HEIGHT | A |

SHEET 1 OF 1

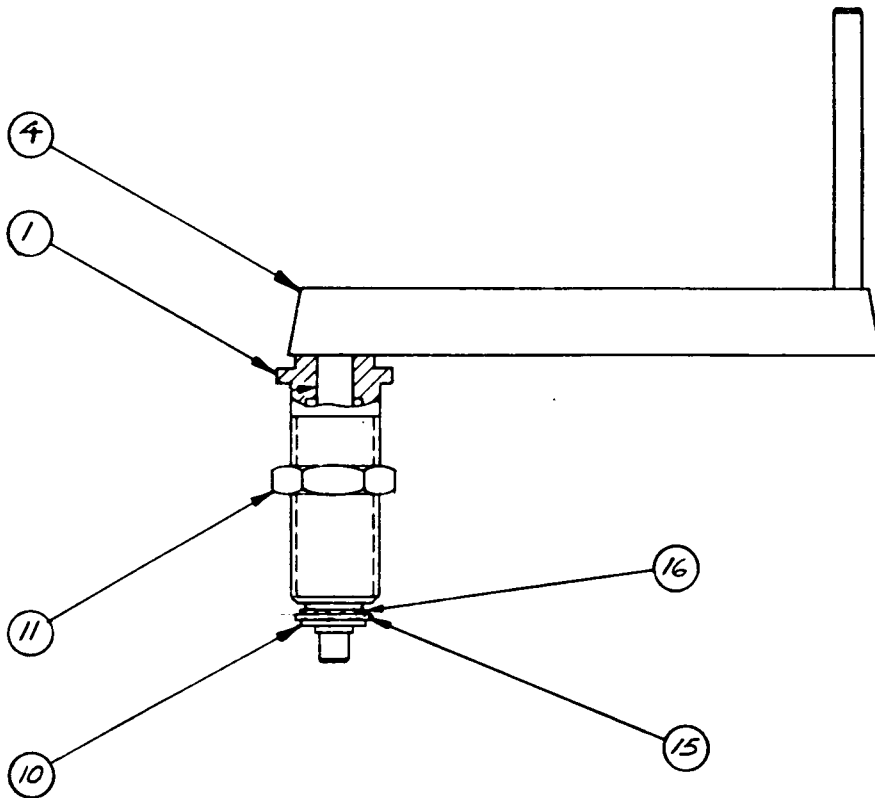

| ITEM NO. | AMPEX PART NO. | REFERENCE NUMBER | DESCRIPTION | JEDEC NO. OR MFR. PART NO. |
|----------|----------------|------------------|-------------------------------------------------|----------------------------|
| | 4030376-01 | | TAPE LIFTER ASSEMBLY (NHA 4020401) | |
| 1 | 4041204-01 | | BLOCK LIFTER ASSY, RIGHT HAND | |
| | 4041205-01 | | BLOCK LIFTER ASSY, LEFT HAND | |
| 5 | 4220291-02 | | STOP, SOLENOID | |
| 6 | 4230253-01 | | LINK, TAPE LIFTER | |
| 9 | 4330302-01 | | PLATE, MTG, SOLENOID | |
| 10 | 4440312-04 | | WASHER, FELT | |
| 13 | 013-678 | | DIODE | |
| 14 | 022-179 | | SOLENOID, 24V | 1N4005 |
| 15 | 180-023 | TB4 | TERMINAL STRIP | |
| 18 | 4270136-01 | | SPRING, 0.250 O.D. X 1.00 LG | |
| 20 | 406-284 | | PIN, FOLL, SPRING, 0.094 DIA X 0.50 LG | |
| 21 | 280-938 | | SLEEVE, BEARING, 0.140 ID X 0.250 OD X 0.250 LG | |
| 23 | 430-090 | | RING, RET | |
| 24 | 473-827 | | SCREW, HEX HD, NO. 6-32 X 1.00 LG | |
| 25 | 471-067 | | SCREW, PAN HD, XREC, NO. 6-32 X 0.25 LG | |
| 26 | 471-078 | | SCREW, PAN HD, XREC, NO. 8-32 X 0.37 LG | |
| 27 | 471-342 | | SCREW, FLAT HD, NO. 6-32 X 1.00 LG | |
| 28 | 471-345 | | SCREW, FLAT HD, NO. 8-32 X 0.37 LG | |
| 30 | 493-006 | | NUT, LOCKING, HEX, NYLON INSERT, NO. 6-32 | |
| 31 | 498-562 | | NUT, THUMB | |
| 32 | 501-009 | | WASHER, PLAIN, NO. 6 | |
| 33 | 501-032 | | WASHER, 0.515 I.D. X 0.87 O.D. X 0.032 THK | |
| 34 | 501-205 | | WASHER, PLAIN, NO. 8 | |
| 35 | 501-736 | | WASHER, NYLON, 0.253 I.D. X 0.31 THK | |
| 36 | 502-003 | | WASHER, LOCK, NO. 6 | |
| 37 | 502-026 | | WASHER, LOCK, NO. 8 | |

E

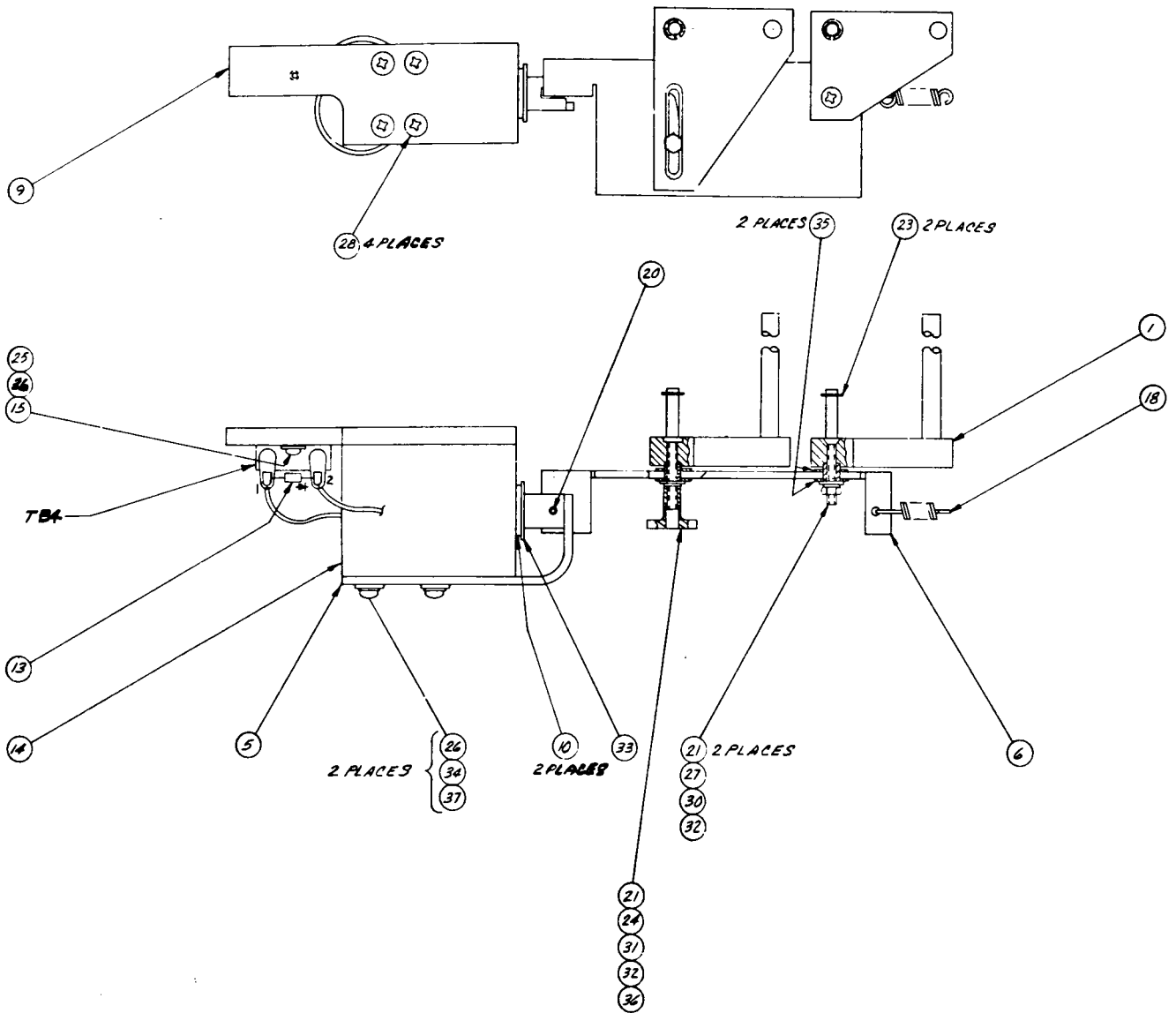

Assembly No. 4030376. Tape Lifter Assembly

| ITEM NO. | AMPEX PART NO. | REFERENCE NUMBER | DESCRIPTION | JEDEC NO. OR MFR. PART NO. |
|----------|----------------|------------------|----------------------------------------|----------------------------|
| | 4030384-02 | | TENSION SENSOR ASSEMBLY (NHA 4020401) | |
| 1 | 4260103-01 | | BRACKET, MTG, LAMP AND PHOTOCELL | |
| 2 | 060-373 | | LAMP, INCANDESCENT, 28V, 0.06 AMP | |
| 3 | 132-313 | | LIGHT FIXTURE, INDICATOR, INCANDESCENT | |
| 4 | 139-514 | | CONNECTOR, RECT, PLUG, 8 PIN | |
| 5 | 172-010 | | TERMINAL LUG, SOLDER, NO. 6 | |
| 7 | 581-204 | | DIODE, PHOTOVOLTAIC, SELENIUM | SX10LB C |

SHEET 1 OF 1

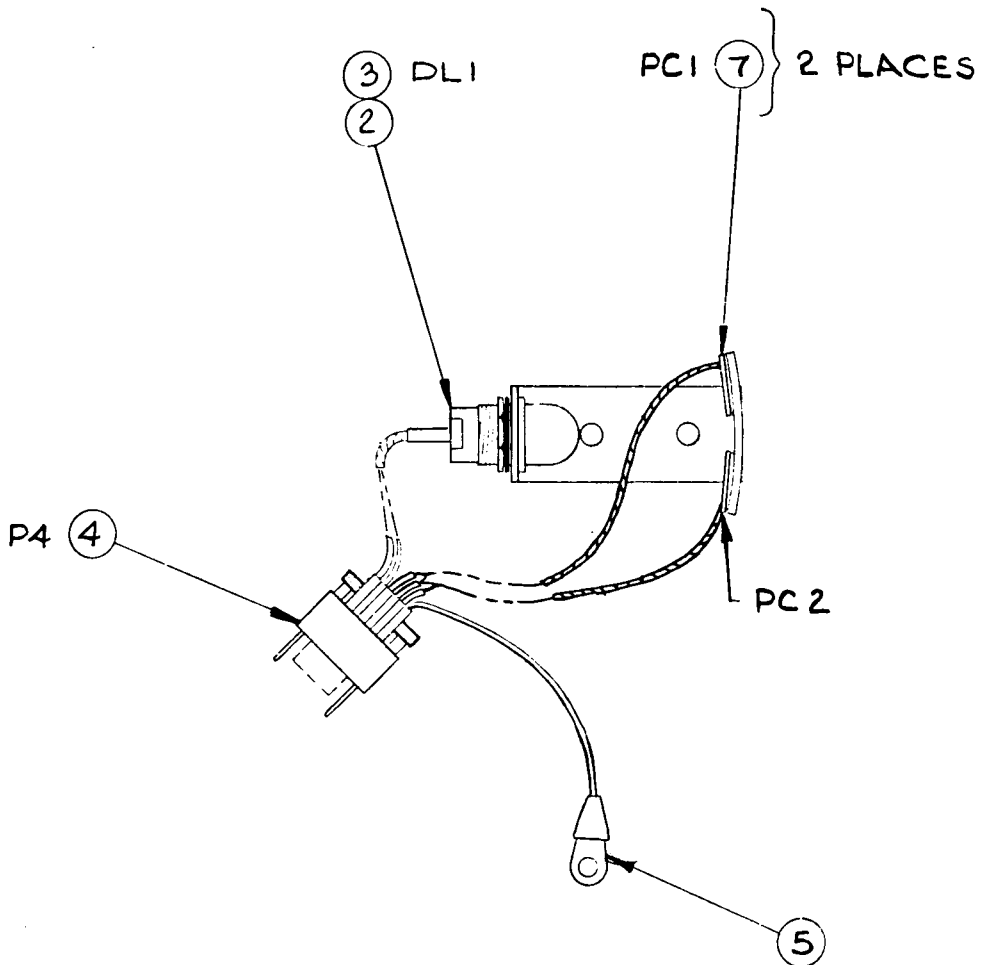

| ITEM NO. | AMPEX PART NO. | REFERENCE NUMBER | DESCRIPTION | JEDEC NO. OR MFR. PART NO. |
|----------|----------------|------------------|-----------------------------------------------------------------------------------------------------------------------------------------------------------------|----------------------------|
| | 1376517-01 | | TAPE GUIDE IDLER ASSEMBLY, TWO-INCH, 16,24 CHANNEL (NHA 4020401) | |
| 1 | 164826-030 | | BEARING, BALL, FLANGED, 0.250 ID BASE AND SHAFT, ROTARY GUIDE, 1-IN CAP, IDLER, ROTARY GUIDE, 1-IN IDLER TAPE GUIDE, 1 IN SPRING, IDLER, TAPE GUIDE | |
| 2 | 168429-01 | | | |
| 3 | 1376518-01 | | | |
| 4 | 1376519-02 | | | |
| 5 | 1376520-01 | | | |
| 6 | 352-415 | | SPRING, COMPRESSION SCREW, CAP, HEX SOC, NO. 6-32 X 3/8 | |
| 7 | 470-069 | | | |

A

SHEET 1 OF 1

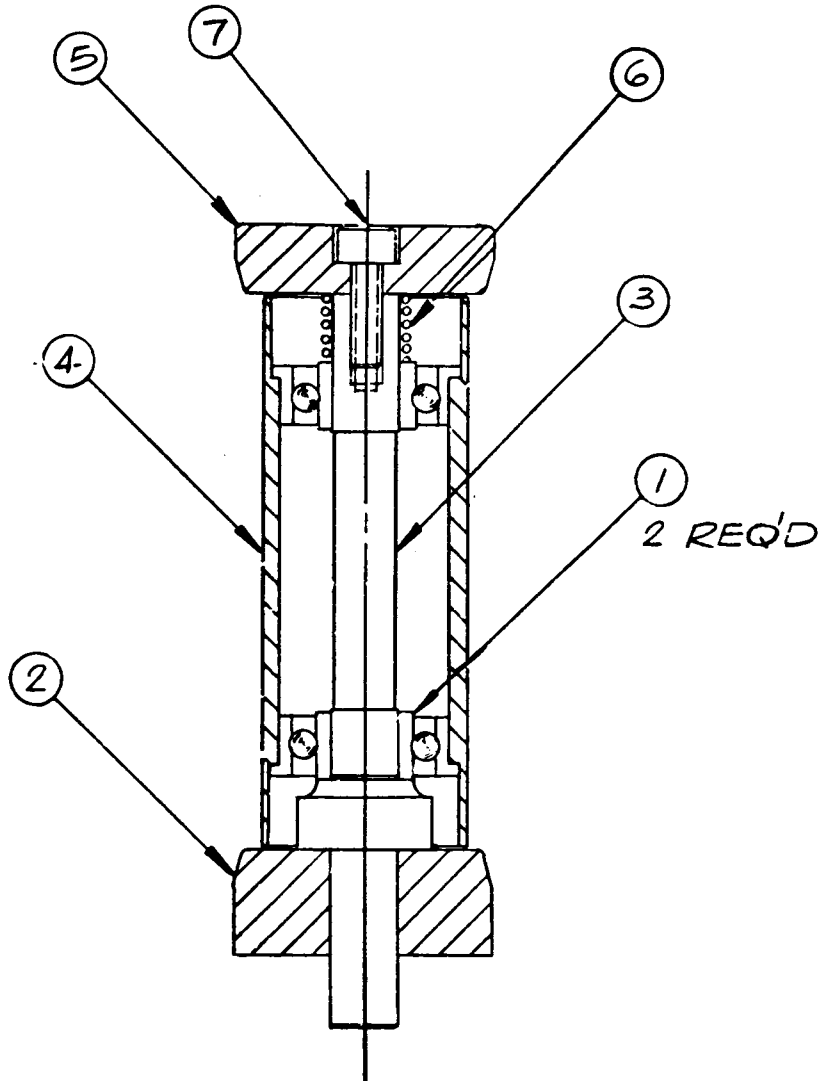

| ITEM NO. | AMPEX PART NO. | REFERENCE NUMBER | DESCRIPTION | JEDEC NO. OR MFR. PART NO. |
|----------|----------------|------------------|--------------------------------------------------------------------------------------------------------------------------------------------------------------------|----------------------------|
| | 4030410-02 | | TAPE GUIDE IDLER ASSEMBLY, ONE-INCH, 8 CHANNEL (NHA 4020401) | |
| 1 | 164826-030 | | BEARING, BALL, FLANGED, 0.250 ID BASE AND SHAFT, ROTARY GUIDE, 1-IN. CAP, IDLER, ROTARY GUIDE, 1-IN. IDLER, TAPE GUIDE, 1-IN SPRING, IDLER, TAPE GUIDE | |
| 3 | 4330356-01 | | | |
| 6 | 4100085-02 | | | |
| 7 | 4250233-01 | | | |
| 8 | 4270138-01 | | | |
| 11 | 470-069 | | SCREW, CAP, HEX SOC, NO. 6-32 X 3/8 | A |
| 13 | 477-700 | | SCREW, SET, 10-32 X 1.0 LG | |

SHEET 1 OF 1

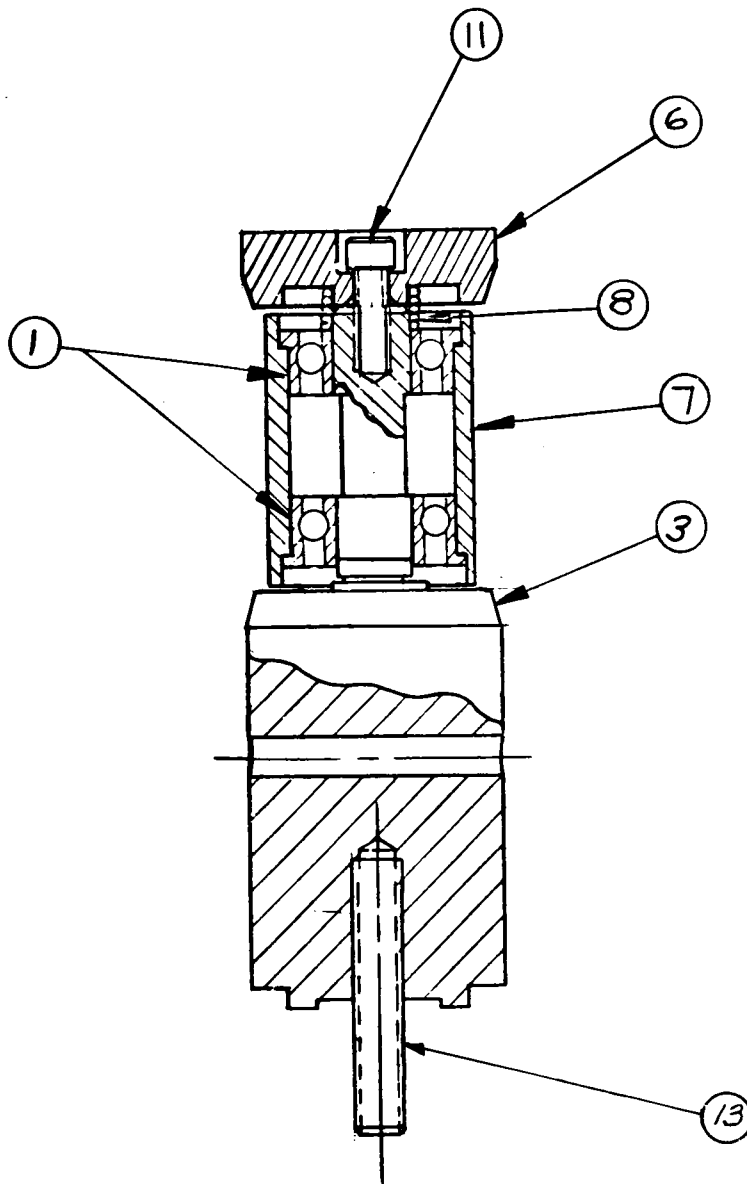

| ITEM NO. | AMPEX PART NO. | REFERENCE NUMBER | DESCRIPTION | JEDEC NO. OR MFR. PART NO. |
|----------|----------------|------------------|----------------------------------------------|----------------------------|
| | 4041194-02 | | TRANSPORT TENSION ARM ASSEMBLY (NHA 4020401) | |
| 1 | 4041181-01 | | TENSION SENSOR ARM ASSY | |
| 3 | 4220128-01 | | BLOCK, MTG, TENSION SENSOR | |
| 4 | 4230148-01 | | ARM, PHOTOCELL COVER | |
| 6 | 4270131-02 | | SPRING, SENSOR | |
| 7 | 4330294-01 | | PLATE, BACKING, SENSING ARM | |
| 8 | 4330312-01 | | PLATE, BACKING | |
| 16 | 470-162 | | SCREW, CAP, NO. 6-32 X 0.375 LG | |
| 17 | 470-021 | | SCREW, CAP, NO. 6-32 X 0.312 LG | |
| 18 | 501-009 | | WASHER, FLAT, NO. 6 | |
| 19 | 502-003 | | WASHER, SPRING, NO. 6 | |
| 20 | 501-188 | | WASHER, PLAIN, NO. 6, 0.267 O.D. | D |

SHEET 1 OF 1

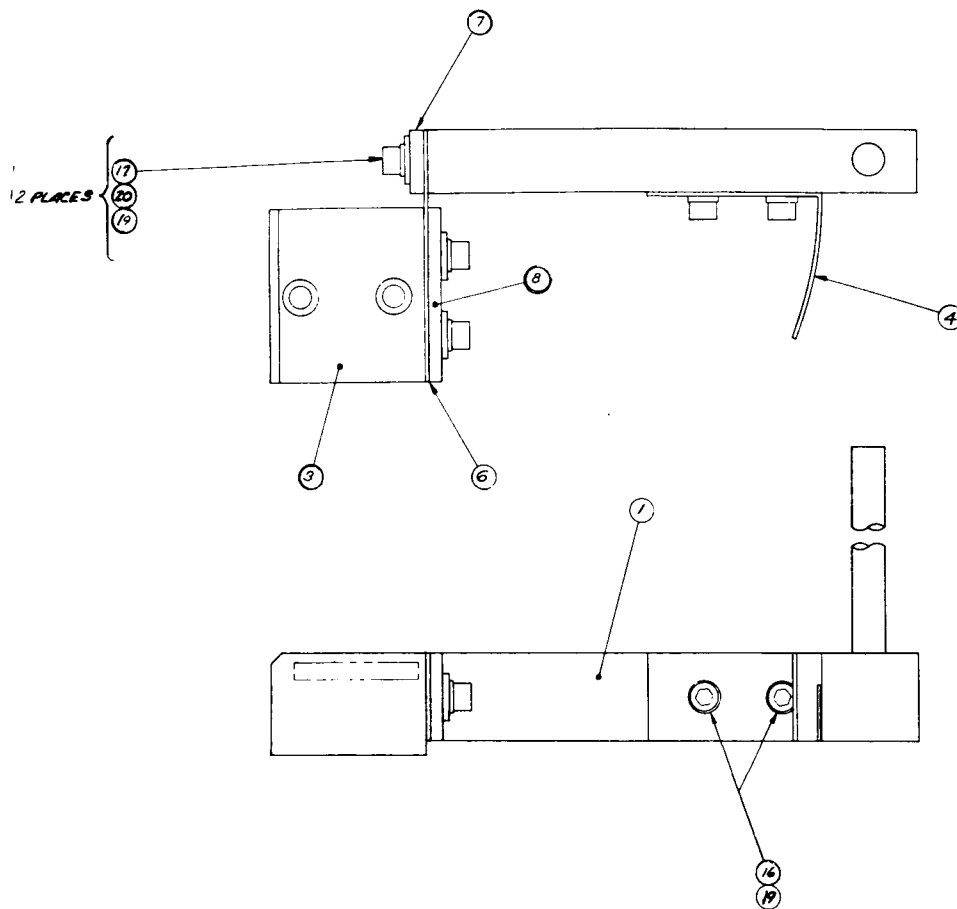

| ITEM NO. | AMPEX PART NO. | REFERENCE NUMBER | DESCRIPTION | JEDEC NO. OR MFR. PART NO. |
|----------|----------------|------------------|--------------------------------------------------|----------------------------|
| | 4050775-01 | | TAPE TRANSPORT HARNESS ASSEMBLY (NHA 4020401) | |
| 1 | 4260481-01 | | BRACKET, MTG, CONN | |
| 7 | 139-515 | J4 | CONNECTOR, 8 SOC, FEMALE | |
| 8 | 144-013 | J2,3 | CONNECTOR, 6 SOC, FEMALE | |
| 9 | 144-030 | P6 | CONNECTOR, 15 SOC, FEMALE | |
| 10 | 144-037 | P2 | CONNECTOR, 2 SOC, FEMALE | |
| 11 | 145-011 | P7,8 | CONNECTOR, 4 PIN, MALE | |
| 12 | 145-019 | P4 | CONNECTOR, 12 PIN, MALE | |
| 13 | 145-020 | P3 | CONNECTOR, 10 PIN, MALE | |
| 14 | 146-003 | J1 | CONNECTOR, 8 SOC, FEMALE | |
| 16 | 166-199 | | CONTACT, SOCKET, 20-22 AWG | |
| 17 | 166-224 | | CONTACT, SOCKET, 24-26 AWG | |
| 18 | 166-225 | | CONTACT, SOCKET, 16-18 AWG | |
| 20 | 167-028 | | BODY, CONN, RECT, PLUG, 36 POS | |
| 23 | 171-001 | | TERMINAL, CRIMP, SPADE LUG | |
| 24 | 171-009 | | TERMINAL, QUICK-DISCONNECT, KNIFE | |
| 27 | 171-238 | | TERMINAL, QUICK-DISCONNECT, FEMALE | |
| 28 | 262-002 | | BUSHING, SLEEVE, FLANGED, 0.220 I.D. | |
| 29 | 262-003 | | BUSHING, SLEEVE, FLANGED, 0.312 I.D. | |

D

SHEET 1 OF 1

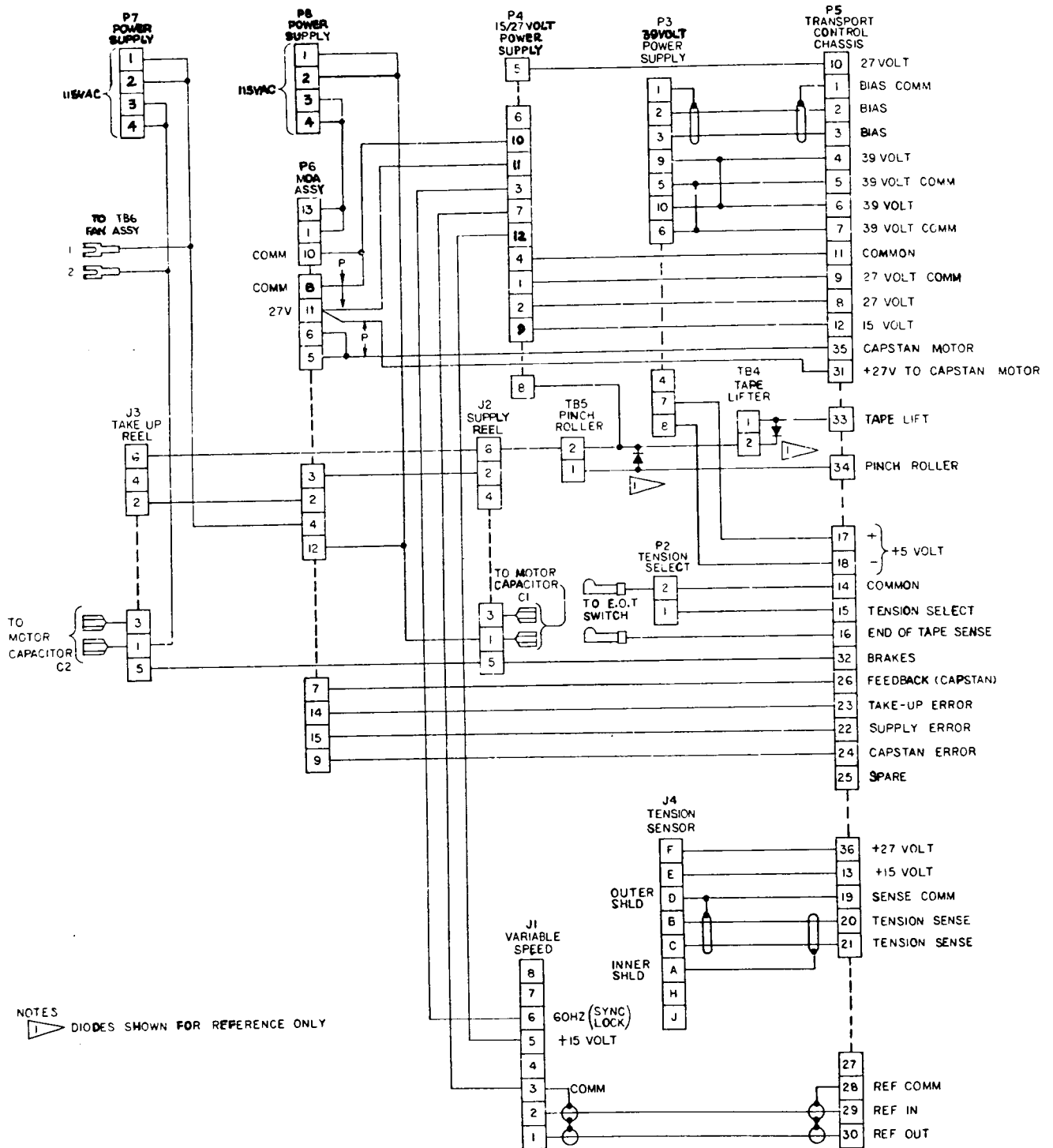

Wiring Diagram No. 4840399B. Tape Transport Harness

| ITEM NO. | AMPEX PART NO. | REFERENCE NUMBER | DESCRIPTION | JEDEC NO. OR MFR. PART NO. |
|----------|----------------|------------------|-------------------------------------|----------------------------|
| | 4952589-04 | | DASHPOT ARM ASSEMBLY (NHA 4020401) | |
| 2 | 4952558-01 | | BRACKET, TAPE TENSION ARM | |
| 3 | 4440308-01 | | NUT, SWIVEL | |
| 6 | 4330324-01 | | PLATE, MAGNET LATCH | |
| 9 | 471-075 | | SCREW, PAN HD, XREC, 6-32 X 1 | |
| 10 | 470-017 | | SCREW, SET, 6-32 X 0.312 | |
| 12 | 496-005 | | NUT, KEP, NO. 6 | |
| 13 | 496-004 | | NUT, KEP, NO. 4 | |
| 14 | 470-136 | | SCREW, CAP, HEX SOC, 4-40 X 0.88 LG | |

H

SHEET 1 OF 1

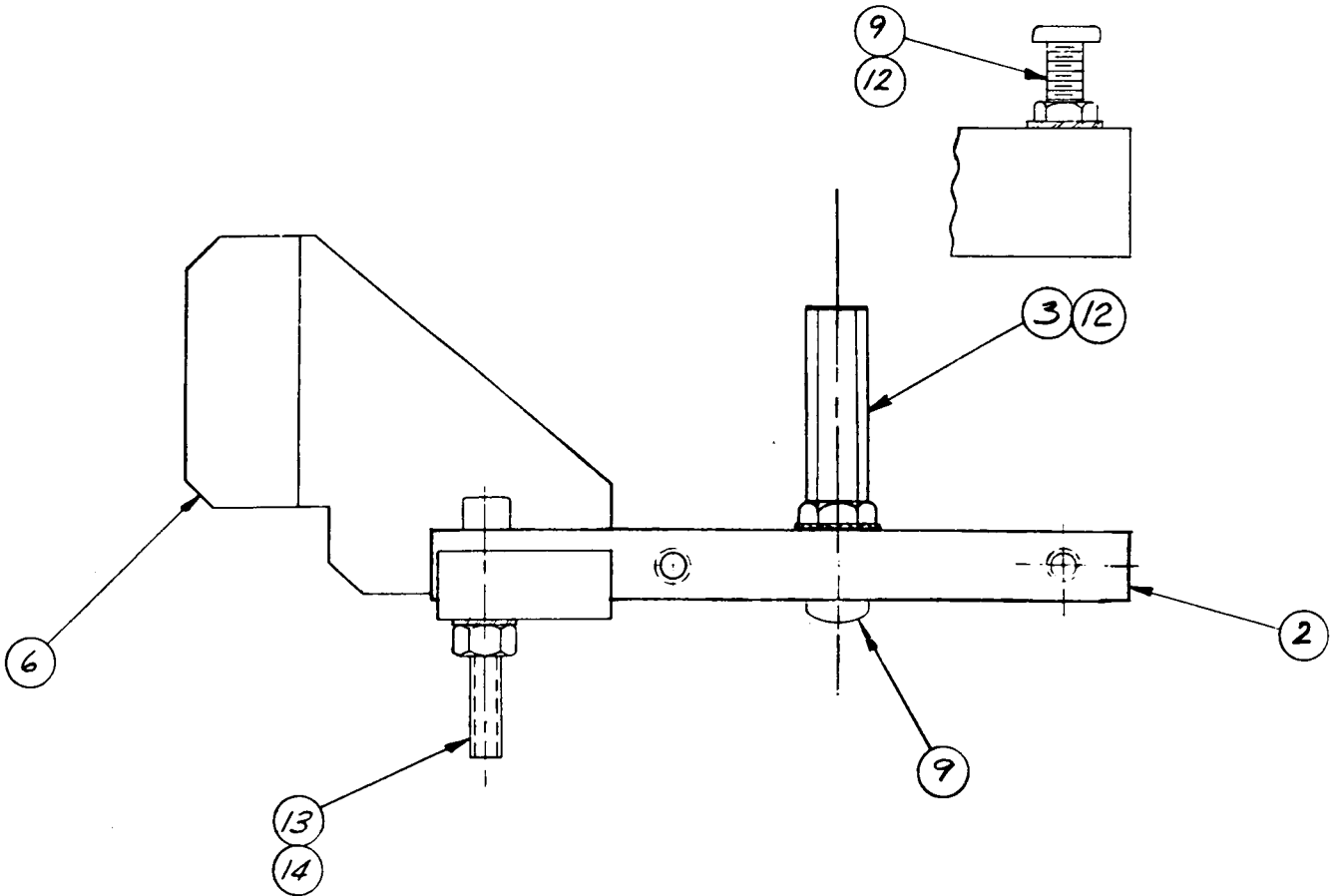

| ITEM NO. | AMPEX PART NO. | REFERENCE NUMBER | DESCRIPTION | JEDEC NO. OR MFR. PART NO. |
|----------|----------------|------------------|-----------------------------------------------------|----------------------------|
| | 55670-05 | | CAPSTAN SOLENOID ASSEMBLY (NHA 4020401) | |
| 1 | 55337-01 | | SPRING, RETURN, SOLENOID | |
| 2 | 55572-01 | | BAR, DRAW | |
| 4 | 55573-01 | | PIN, DRAW | |
| 7 | 55673-02 | | BRACKET, MTG, SOLENOID | |
| 9 | 1380008-01 | | SOLENOID | |
| 11 | 4270118-01 | | SPRING, ADJ, SOLENOID | |
| 16 | | | GREASE | MOLY LUBE |
| 17 | 171-001 | | CONNECTOR, SOLDERLESS, SLOTTED TONGUE | |
| 18 | 180-075 | | TERMINAL STRIP, BARRIER, 2 TERM | |
| 20 | 401-004 | | PIN, COTTER, 1/16 DIA X 3/8 LONG | |
| 22 | 475-018 | | SCREW, SLTD, PAN HD, ASSEM WASHER, 6-32 X 5/8 LG | |
| 25 | 501-004 | | WASHER, FLAT, NO. 8 X 0.032 THK | |
| 26 | 501-011 | | WASHER, FLAT, NO. 10 | |
| 28 | 502-005 | | WASHER, LOCK, SPRING, NO. 10 | |
| 31 | 493-008 | | NUT, ELASTIC, STOP, NO. 10 | |
| 34 | 501-188 | | WASHER, FLAT, NO. 6, 0.016 THK | |
| 36 | 280-404 | | SPACER, PLAIN, 0.194 I.D. X 0.500 O.D. X 0.5 LG | |
| 37 | 013-678 | | DIODE | 1N4005 |

U

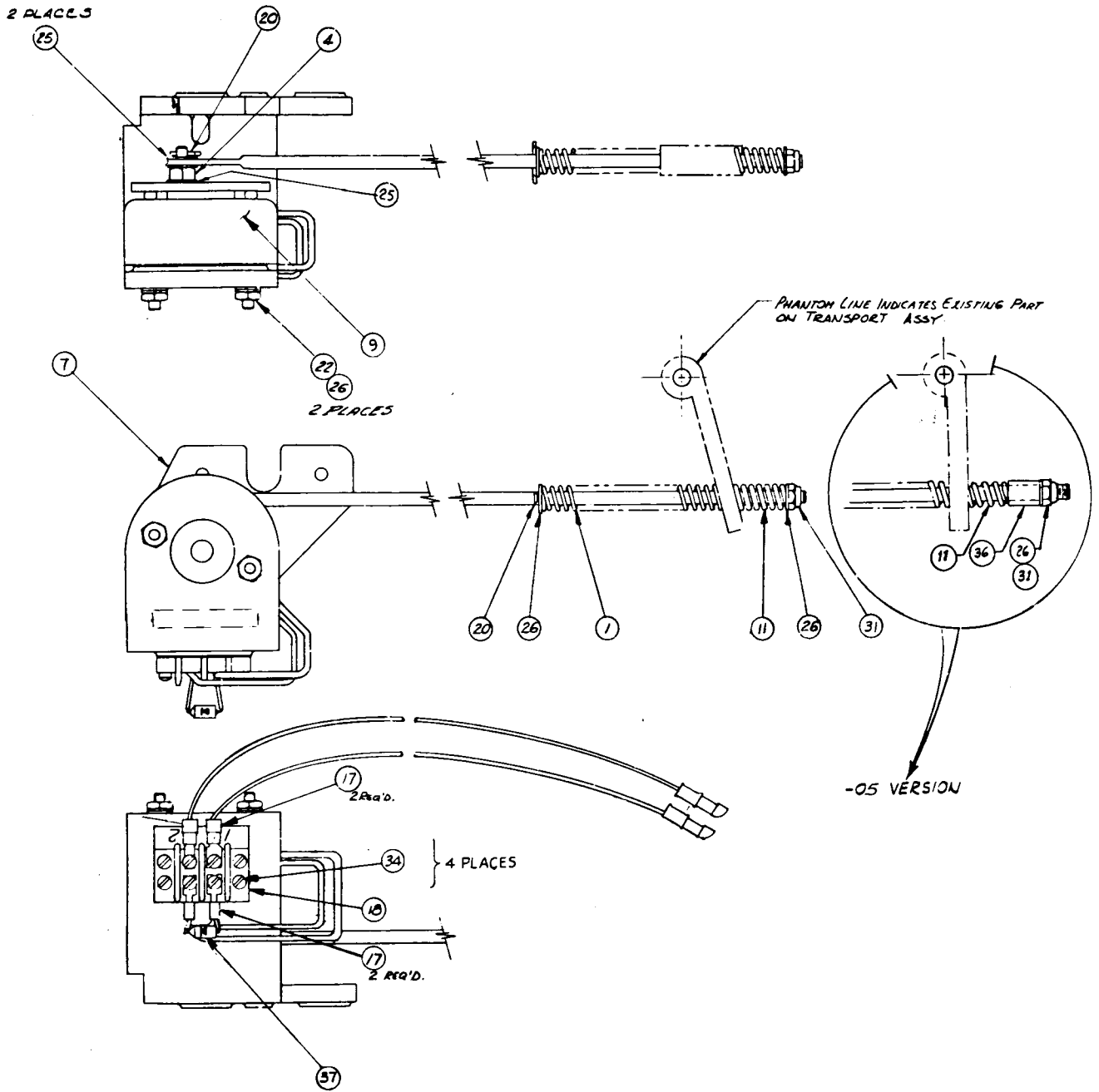

Assembly No. 55670. Capstan Solenoid Assembly

| ITEM NO. | AMPEX PART NO. | REFERENCE NUMBER | DESCRIPTION | JEDEC NO. OR MFR. PART NO. |
|----------|--------------------------|------------------|--------------------------------------------------------------------------------------------------|----------------------------|
| | 4020402-05 4020402-06 | | ELECTRONICS ASSEMBLY, 15-30 IN/S (NHA 4010240) ELECTRONICS ASSEMBLY 7.5-15 IN/S (NHA 4010240) | |
| 1 | 4050433-08 | | BIAS AMPLIFIER PWA | |
| 3 | 4050435-12 | | REPRODUCE AMPLIFIER PWA, 7.5-15 IN/S | |
| 4 | 4050435-15 | | REPRODUCE AMPLIFIER PWA, 15-30 IN/S | |
| 5 | 4050774-03 | | AUDIO SWITCHING PWA | |
| 9 | 4041212-02 | | COVER ASSY, ELECTRONICS | |
| 10 | 4050765-02 | | REAR PANEL ASSEMBLY | |
| 11 | 4290783-02 | | CHASSIS, ELECTRONICS | |
| 13 | 4050434-04 | | RECORD AMPLIFIER PWA | |
| 15 | 4290830-01 | | GUARD, FINGER | |
| 16 | 4580200-01 | | TRANSFORMER, INPUT | |
| 18 | 251-112 | | PLUG, HOLE | |
| 19 | 460-544 | | RIVET, PUSH | |
| 21 | 530-159 | | GUIDE, CARD, 1/16 INCH | |
| 22 | 530-348 | | GUIDE, CARD, 1/8 INCH | |
| 23 | 496-004 | | NUT, KEP, NO. 4-40 | |
| 25 | 471-063 | | SCREW, PAN HD, XREC, NO. 4-40 X 0.44 LG | |
| 26 | 473-330 | | SCREW, PAN HD, XREC, ASSEM WASHER, NO. 6-32 X 0.25 LG | |
| 27 | 475-058 | | SCREW, PAN HD, XREC, ASSEM WASHER, NO. 6-32 X 0.38 LG | |
| 28 | 475-062 | | SCREW, PAN HD, XREC, ASSEM WASHER, NO. 6-32 X 0.62 LG | |
| 30 | 501-009 | | WASHER, PLAIN, NO. 6 | |
| 36 | 4840408 | | INTERCONNECT DIAGRAM | |

E

SHEET 1 OF 1

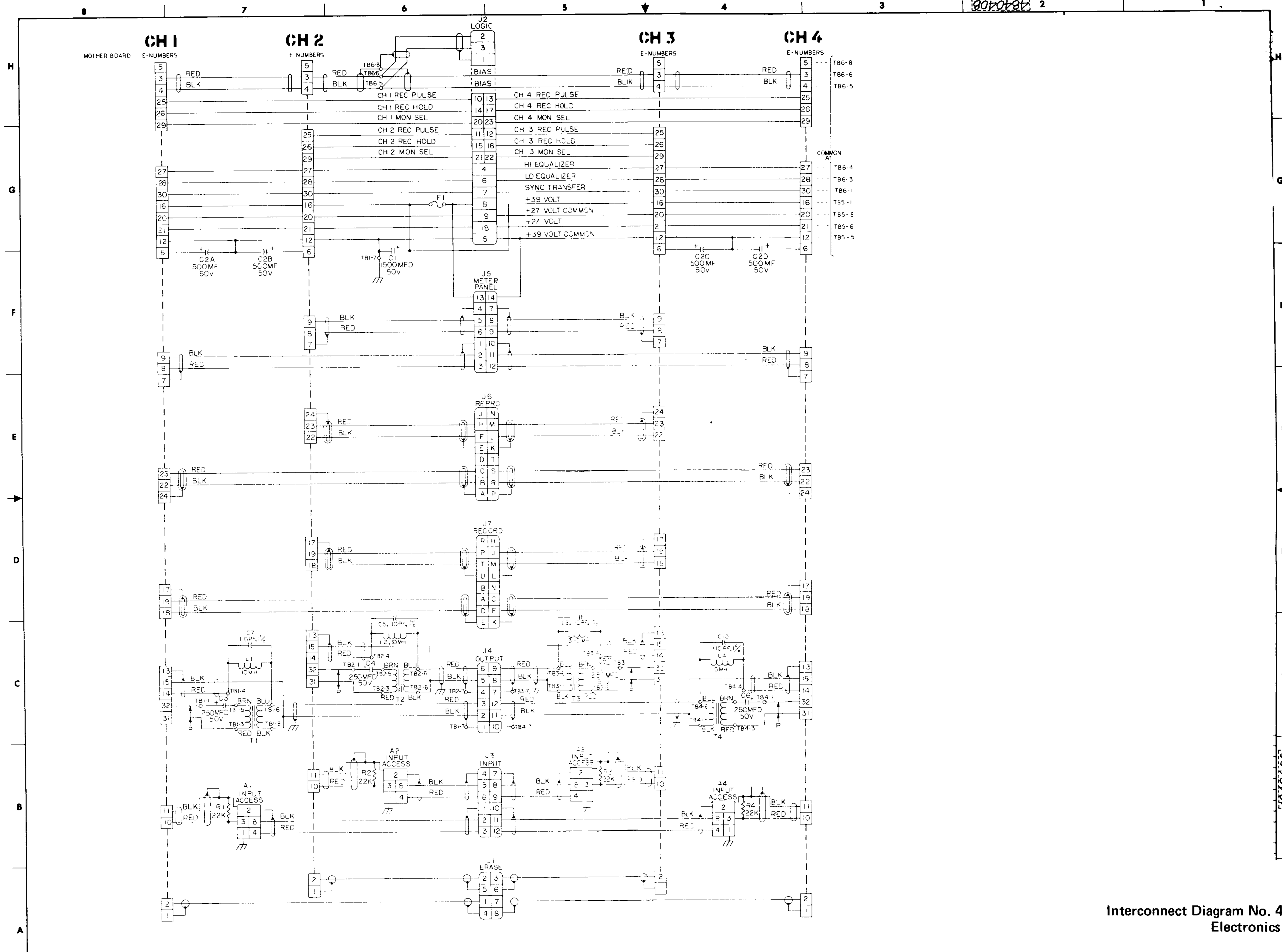

Interconnect Diagram No. 4840408B.
Electronics Assembly

| ITEM NO. | AMPEX PART NO. | REFERENCE NUMBER | DESCRIPTION | JEDEC NO. OR MFR. PART NO. |
|----------|----------------|------------------|----------------------------------------|----------------------------|
| | 4050433-08 | | BIAS AMPLIFIER PWA (NHA 4020402) | |
| 2 | 4040972-01 | | BRACKET, BIAS EQUALIZATION | |
| 3 | 4110269-01 | | LABEL, BIAS MODULE | |
| 4 | 4330261-02 | | PLATE, FRONT, BIAS MODULE | |
| 5 | 4520154-01 | R44 | POTENTIOMETER, BIAS CALIBRATE, 750 OHM | |
| 6 | 4520145-20 | R80 | POTENTIOMETER, BIAS ADJUST, 25K | |
| 7 | 4580123-01 | T3,4 | COIL, OSCILLATOR | |
| 18 | 014-329 | Q16,17 | TRANSISTOR | 2N2102 |
| 19 | 014-653 | Q18,19 | TRANSISTOR | 2N3904 |
| 20 | 031-190 | C44 | CAPACITOR, ELEC, 50 UF, 25V, -10 + 75% | |
| 21 | 034-994 | C42 | CAPACITOR, MICA, 2500 PF, 500V, 5% | |
| 22 | 034-960 | C45 | CAPACITOR, MICA, 5000 PF, 300V, 5% | |
| 24 | 041-031 | R90,91 | RESISTOR, COMP, 1 MEG, 1/2W, 10% | |
| 25 | 041-033 | R87 | RESISTOR, COMP, 22 OHM, 1/2W, 10% | |
| 26 | 041-345 | R83 | RESISTOR, COMP, 51 OHM, 1/2W, 5% | |
| 27 | 041-353 | R86 | RESISTOR, COMP, 1.6K, 1W, 5% | |
| 29 | 041-529 | R88,89 | RESISTOR, COMP, 20K, 1/2W, 5% | |
| 30 | 055-106 | C41,43 | CAPACITOR, MYLAR, 0.1 UF, 100V, 10% | |
| 31 | 059-017 | R82 | RESISTOR, WW, 180 OHM, 5W, 5% | |
| 32 | 280-131 | | PAD, MTG, TRANSISTOR, 0.200 DIA | |
| 33 | 475-006 | | SCREW, SEM, PAN HD, NO. 4-40 X 1/4 LG | |
| 34 | 492-046 | | NUT, HEX, 1/4-32 | |
| 35 | 492-095 | | NUT, HEX, 3/8-32 | |
| 36 | 501-008 | | WASHER, FLAT, NO. 4 | |
| 37 | 502-028 | | WASHER, FLAT, INT TOOTH, 1/4 INCH | |
| 38 | 502-059 | | WASHER, FLAT, INT TOOTH, NO. 12 | |
| 39 | 502-083 | | WASHER, FLAT, INT TOOTH, 3/8 | |
| 42 | 034-928 | C39 | CAPACITOR, MICA, 620 PF, 500V, 5% | |
| 43 | 475-007 | | SCREW, PAN HD, SEM, NO. 4-40 X 5/16 LG | |
| 44 | 038-011 | C40 | CAPACITOR, VAR, 1400-3055 PF, 250V | |
| 46 | 103307-01 | | STANDOFF, REF: R82 | |
| 47 | 041-245 | R84 | RESISTOR, COMP, 1K, 1/2 W, 5% | |
| 48 | 044-944 | R92 | RESISTOR, VAR, CER, 5K, 20% | |
| 49 | 041-475 | R85 | RESISTOR, COMP, 3K, 1/2W, 5% | |
| 80 | 4840249 | | SCHEMATIC | |

M

SHEET 1 OF 1

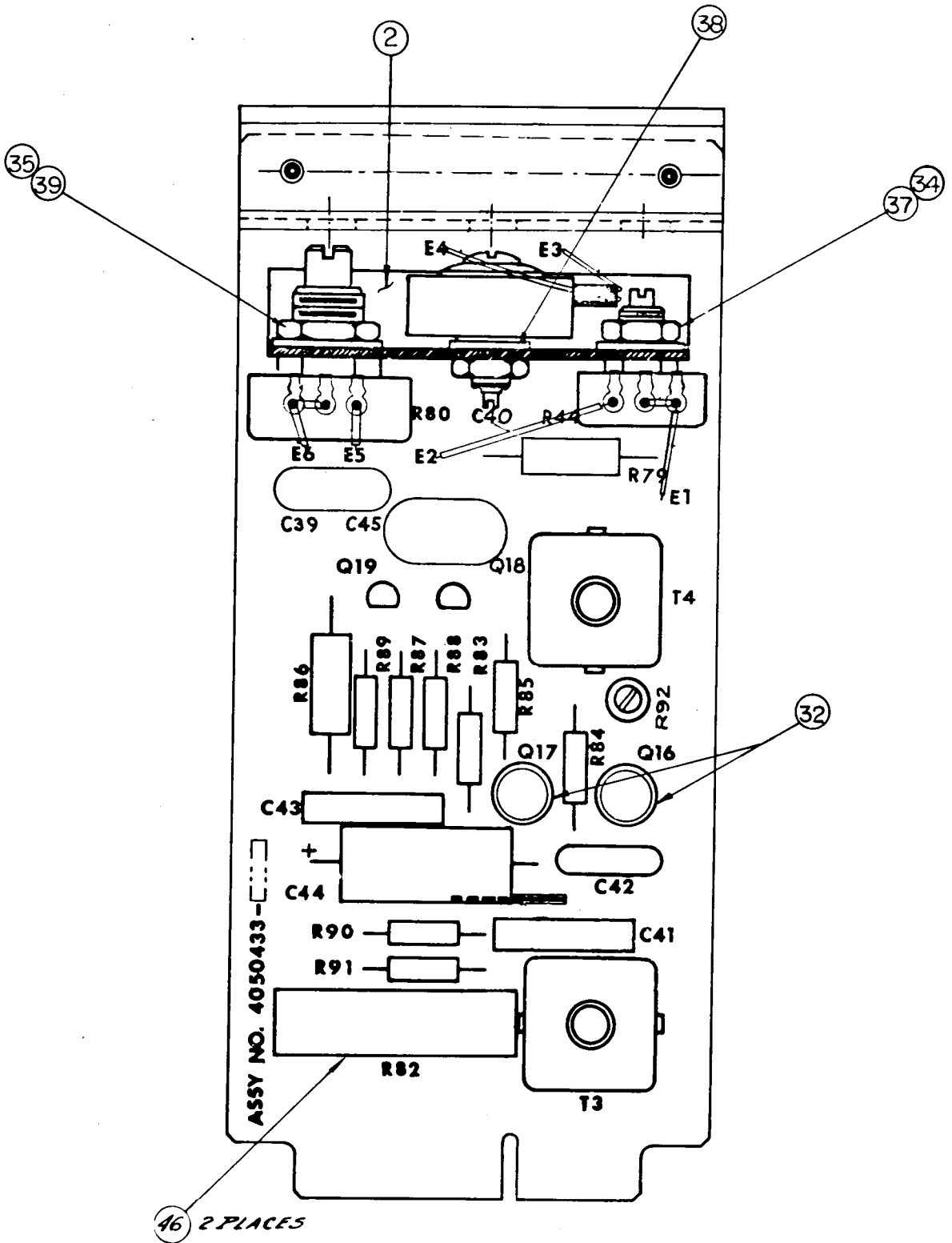

Assembly No. 4050433. Bias Amplifier PWA

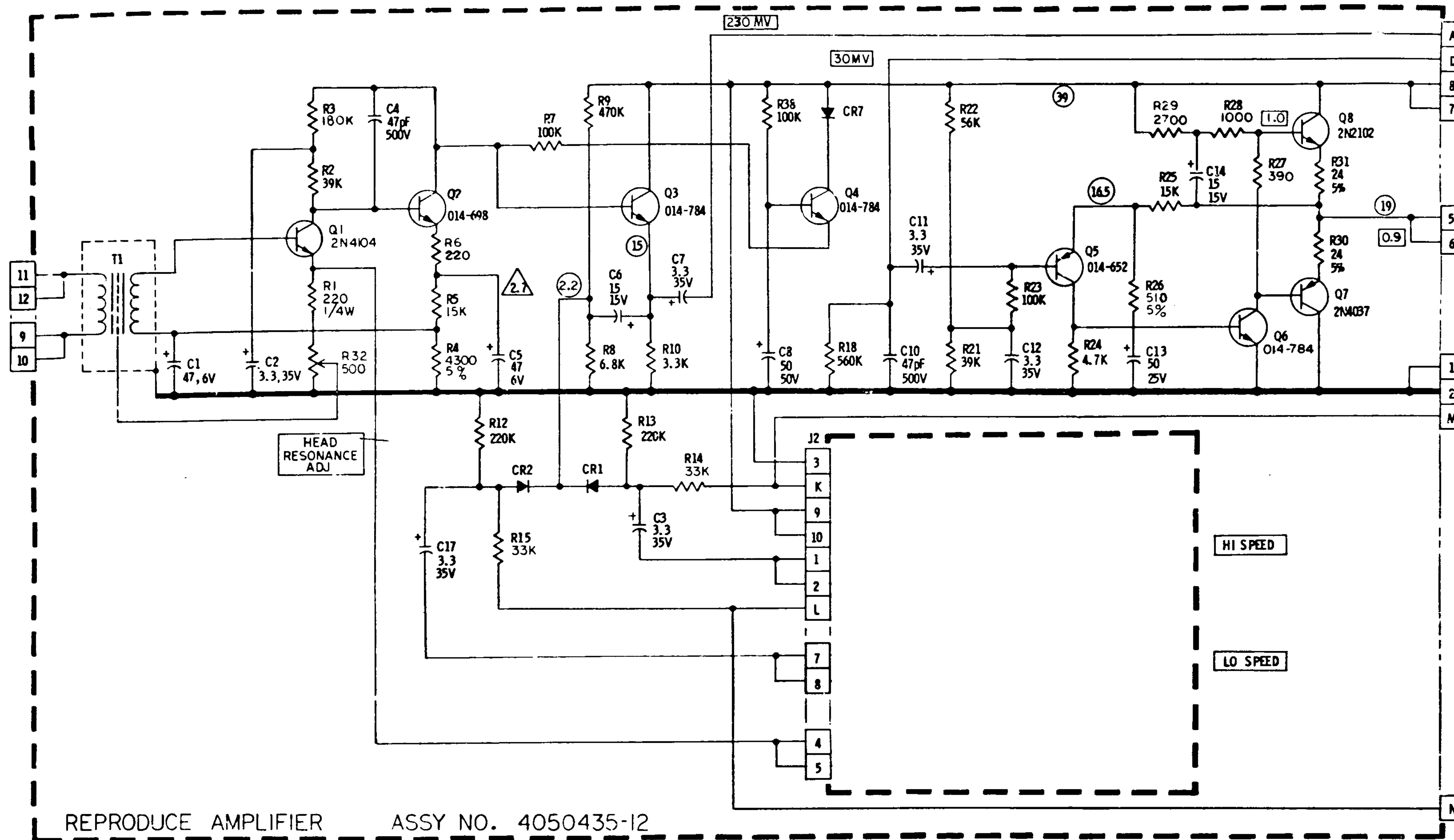

REPRODUCE AMPLIFIER ASSY NO. 4050435-12

- NOTES: UNLESS OTHERWISE SPECIFIED
1. CAPACITANCE VALUES ARE IN MICROFARADS
 2. DIODES ARE TYPE 013-599.
 3. .0047 FOR 4020270-01 EQUALIZER, .0033 FOR 4020270-02
 4. RESISTANCE VALUES ARE IN OHMS 1/2W, 10%.
 5. (XX) INDICATES VOLTS D.C. MEASURED WITH A 20,000 OHM/VOLT METER.
 6. (Δ) INDICATES VOLTS D.C. MEASURED WITH A HIGH IMPEDANCE VTVM.
 7. (XX) INDICATES VOLTS R.M.S. MEASURED WITH A HIGH IMPEDANCE VTVM AT OPERATING LEVEL OF 700 Hz., +8VU OUT, 75 MIL TRACK HEADS.
 8. (XX) INDICATES VOLTS R.M.S. MEASURED WITH A HIGH IMPEDANCE VTVM AT BIAS FREQUENCY.
 9. EQUALIZER 4020270-01 CAN BE ADJUSTED FOR 3 3/4 THRU 15 IPS, NAB OR CCIR. EQUALIZER 4020270-02 CAN BE ADJUSTED FOR 7 1/2 THRU 30 IPS, NAB OR CCIR.

| REF. DES. | AMPEX P/N | NEAREST COML. EQUIVALENT |
|---------------|-----------|--------------------------|
| CR1, CR2, CR7 | 013-599 | 1N914 |
| Q14 | 014-247 | 2N2219 |
| Q5 | 014-652 | 2N3906 |
| Q18, Q19 | 014-653 | 2N3904 |
| Q15 | 014-678 | 2N2219A |
| Q2, Q9-12 | 014-698 | 2N3117 OR 2N5088 |
| Q3, 4, 13, 6 | 014-784 | 2N4946 |

- (10) 51Ω, 5% EXCEPT 180Ω, 10% FOR USE WITH 1/4 TRACK ERASE HEADS.
 (11) ADJUST R92 FOR MINIMUM NOISE FROM TAPE. IF NOISE NULL CANNOT BE FOUND, CHECK COMPONENTS FOR IMBALANCE OR HEADS FOR MAGNETIZATION

7 1/2-15 In/S

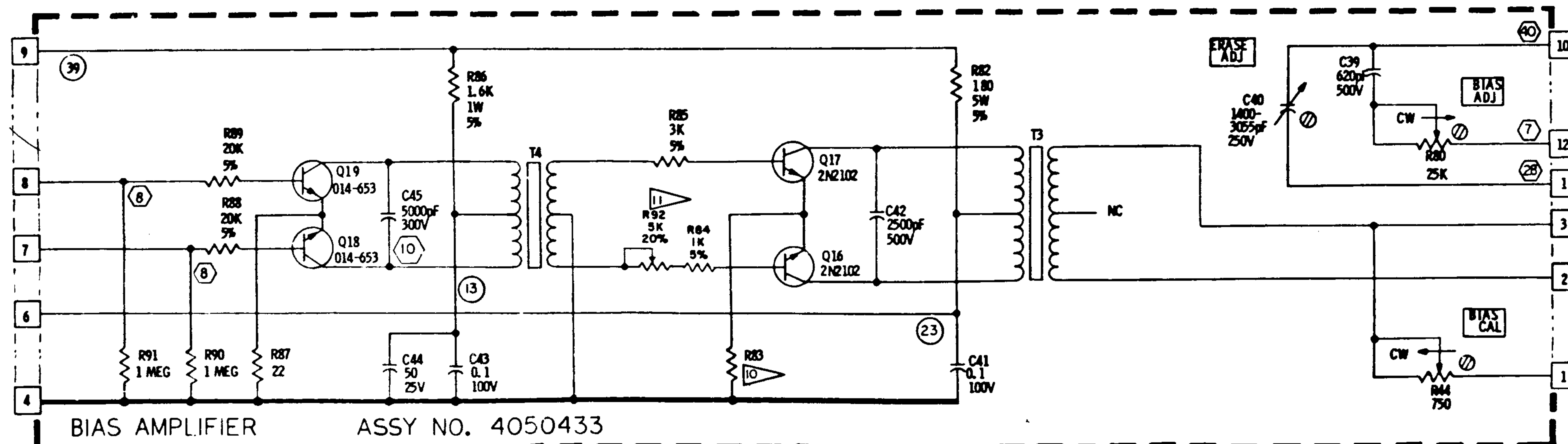

BIAS AMPLIFIER ASSY NO. 4050433

Schematic No. 4840249D. Bias and Reproduce Amplifier PWA's

| ITEM NO. | AMPEX PART NO. | REFERENCE NUMBER | DESCRIPTION | JEDEC NO. OR MFR. PART NO. |
|----------|----------------|------------------|---------------------------------------|----------------------------|
| | 4050434-04 | | RECORD AMPLIFIER PWA (NHA 4020402) | |
| 2 | 4330262-02 | | PLATE, FRONT, RECORD MODULE | |
| 5 | 031-148 | C28 | CAPACITOR, ELECT, 10 UF, 25V, -10+75% | |
| 6 | 037-446 | C32 | CAPACITOR, TANT, 15 UF, 15V, 20% | |
| 7 | 037-494 | C26,29,31 | CAPACITOR, TANT, 47 UF, 6V, 20% | |
| 9 | 055-106 | C24,30 | CAPACITOR, MYLAR, 0.1 UF, 100V, 10% | |
| 10 | 041-012 | R56,61 | RESISTOR, COMP, 4.3K, 1/2W, 5% | |
| 11 | 041-024 | R51,52 | RESISTOR, COMP, 110K, 1/2W, 5% | |
| 12 | 041-038 | R50,72 | RESISTOR, COMP, 100 OHM, 1/2W, 10% | |
| 13 | 041-054 | R66 | RESISTOR, COMP, 3.3K, 1/2W, 10% | |
| 14 | 041-060 | R55,60 | RESISTOR, COMP, 10K, 1/2W, 10% | |
| 15 | 041-064 | R49,63 | RESISTOR, COMP, 22K, 1/2W, 10% | |
| 16 | 041-067 | R53,58 | RESISTOR, COMP, 39K, 1/2W, 10% | |
| 17 | 041-068 | R69 | RESISTOR, COMP, 47K, 1/2W, 10% | |
| 18 | 041-069 | R65 | RESISTOR, COMP, 56K, 1/2W, 10% | |
| 19 | 041-070 | R62 | RESISTOR, COMP, 68K, 1/2W, 10% | |
| 20 | 041-072 | R57,64 | RESISTOR, COMP, 100K, 1/2W, 10% | |
| 21 | 041-078 | R68 | RESISTOR, COMP, 330K, 1/2W, 10% | |
| 22 | 041-080 | R67 | RESISTOR, COMP, 470K, 1/2W, 10% | |
| 23 | 041-082 | R70 | RESISTOR, COMP, 680K, 1/2W, 10% | |
| 24 | 041-241 | R71 | RESISTOR, COMP, 150 OHM, 1/2W, 10% | |
| 25 | 041-361 | R54,59 | RESISTOR, COMP, 7.5K, 1/2W, 5% | |
| 26 | 041-377 | R47 | RESISTOR, COMP, 1.3M, 1/2W, 5% | |
| 27 | 041-898 | R48 | RESISTOR, COMP, 1.1M, 1/2W, 5% | |
| 29 | 280-131 | | PAD, MTG, TRANSISTOR | |
| 30 | 475-006 | | SCREW, SEM, PAN HD, NO. 4-40 X 1/4 | |
| 31 | 501-008 | | WASHER, FLAT, NO. 4 | |
| 32 | 4030270-01 | J9 | CONNECTOR ASSY, 10 CONTACT | |
| 34 | 4110270-01 | | LABEL, RECORD MODULE | |
| 35 | 014-784 | Q13 | TRANSISTOR | 2N4416 |
| 36 | 014-678 | Q15 | TRANSISTOR | 2N3945 |
| 37 | 014-247 | Q14 | TRANSISTOR | 2N2219 |
| 38 | 014-698 | Q9-12 | TRANSISTOR | 2N3565 |
| 39 | 067-026 | C25,27 | CAPACITOR, TANT, 68 UF, 25V, 5% | |
| 40 | 034-181 | C33 | CAPACITOR, TANT, 47 PF, 500V, 5% | |
| 50 | 4840431 | | SCHEMATIC | |

L

SHEET 1 OF 1

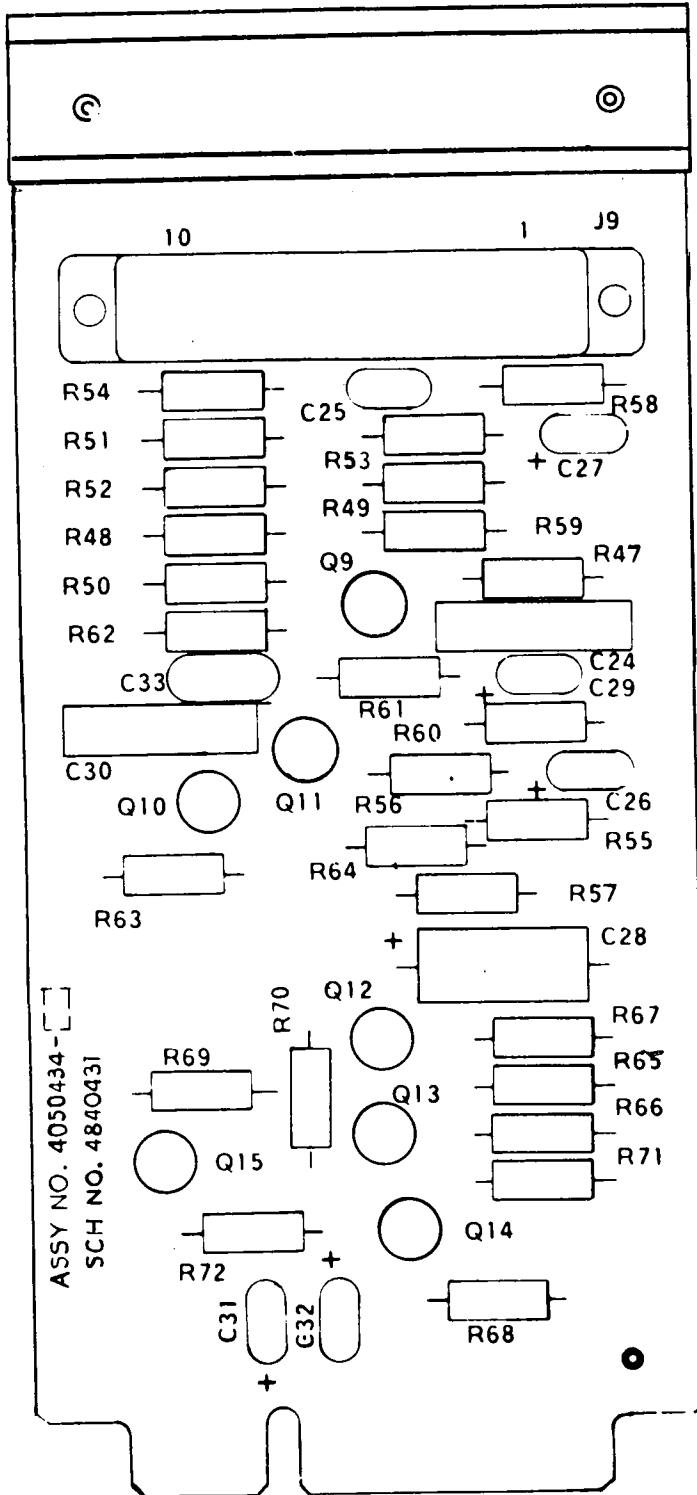

Assembly No. 4050434. Record Amplifier PWA

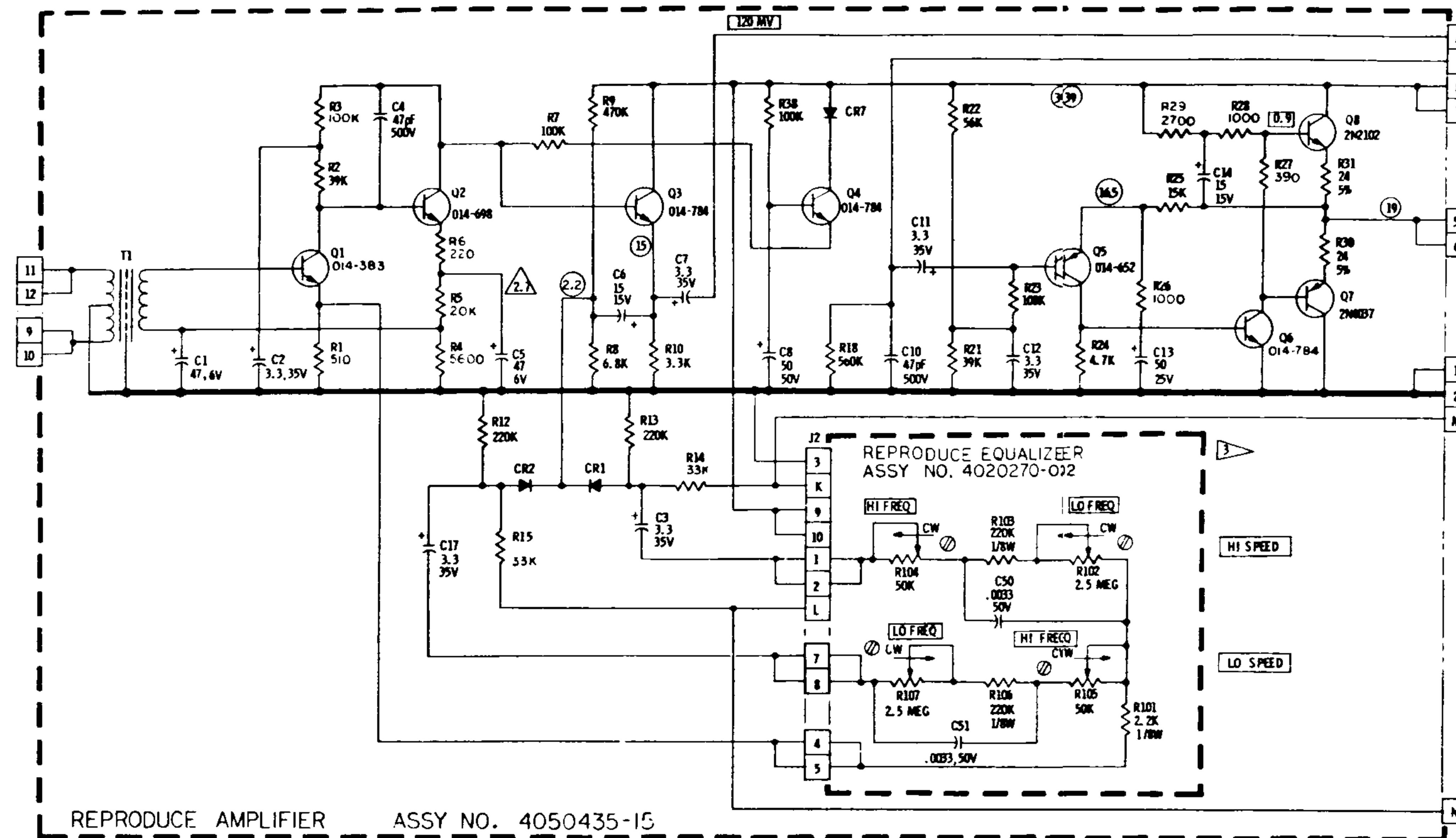

NOTES: UNLESS OTHERWISE SPECIFIED

1. CAPACITANCE VALUES ARE IN MICROGRADS
2. DIODES ARE TYPE 013-599.
3. REPRODUCE EQUALIZER 4020270-02 CAN BE ADJUSTED TO NAB AND/OR CCIR.
4. RESISTANCE VALUES ARE IN OHMS 1/2W, 10%.
5. (X) INDICATES VOLTS D.C. MEASURED WITH A 20,000 OHM/VOLT METER.
6. (Δ) INDICATES VOLTS D.C. MEASURED WITH A HIGH IMPEDANCE VTVM.
7. (XX) INDICATES VOLTS R.M.S. MEASURED WITH A HIGH IMPEDANCE VTVM AT OPERATING LEVEL OF 1000 Hz.
8. (⊗) INDICATES VOLTS R.M.S. MEASURED WITH A HIGH IMPEDANCE VTVM AT BIAS FREQUENCY.
9. REFERENCE DRAWING 4840344, SCHEMATIC, AUDIO SWITCHING.
10. FIELD SERVICE COMPONENT SUBSTITUTION:

| REF. DES. | AMPEX PIN | NEAREST COMPL. EQUIVALENT |
|---------------|-----------|---------------------------|
| CR1, CR2, CR7 | 013-596 | 1N914 |
| Q14 | 014-247 | 2N2219 |
| Q5 | 014-452 | 2N4906 |
| Q18, Q19 | 014-453 | 2N4904 |
| Q15 | 014-678 | NONE |
| Q2, Q9-12 | 014-698 | NONE |
| Q3, 4, 13, 6 | 014-784 | NONE |
| Q1 | 014-383 | 2N4104 |

ADJUST R92 FOR MINIMUM NOISE FROM TAPE. IF NOISE NULL CANNOT BE FOUND, CHECK COMPONENTS FOR IMBALANCE OR HEADS FOR MAGNETIZATION.

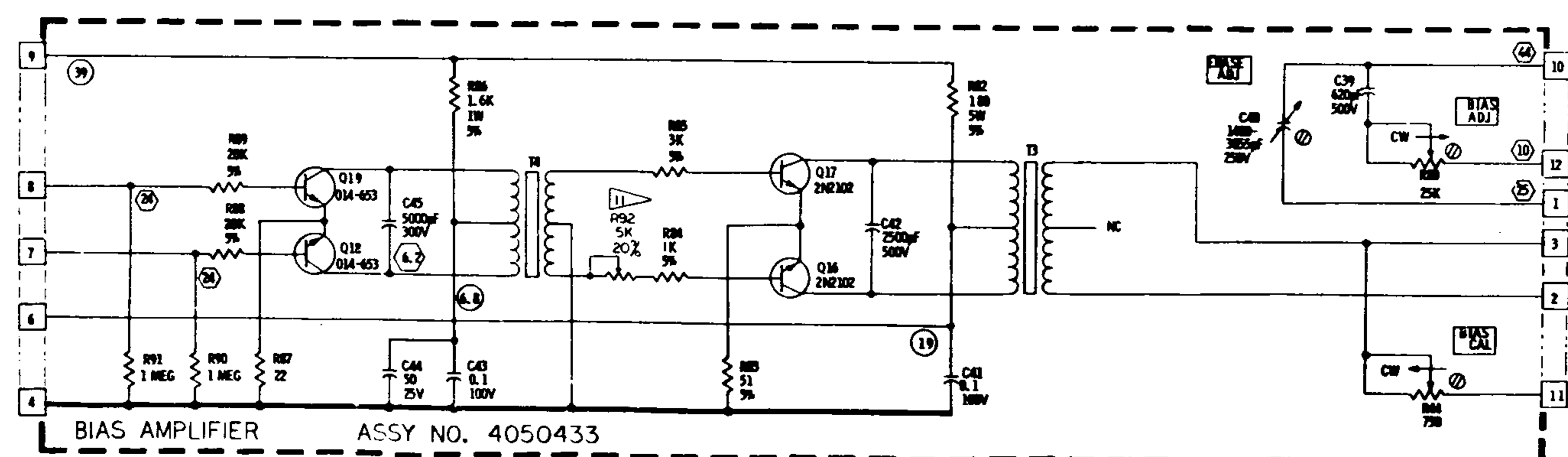
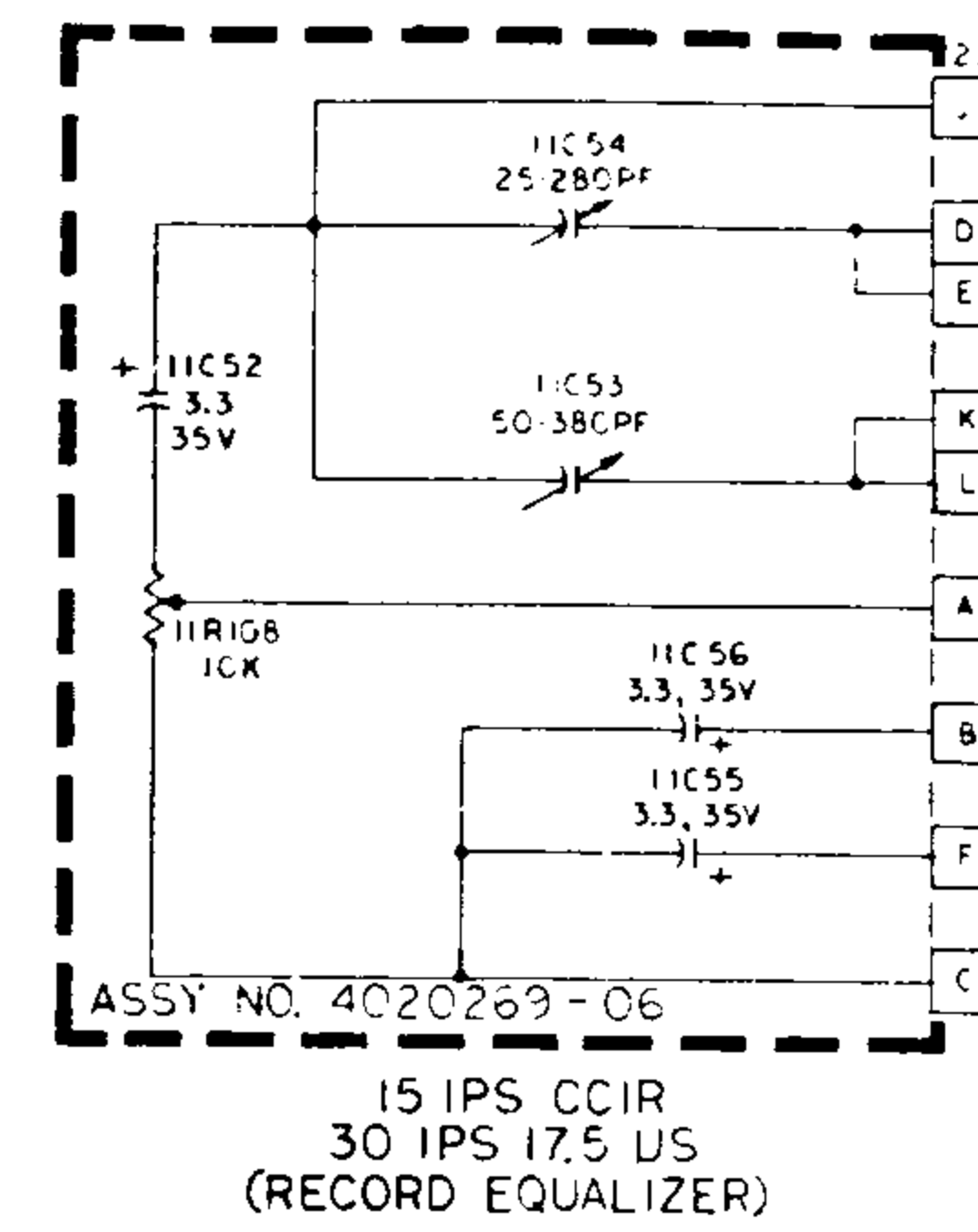
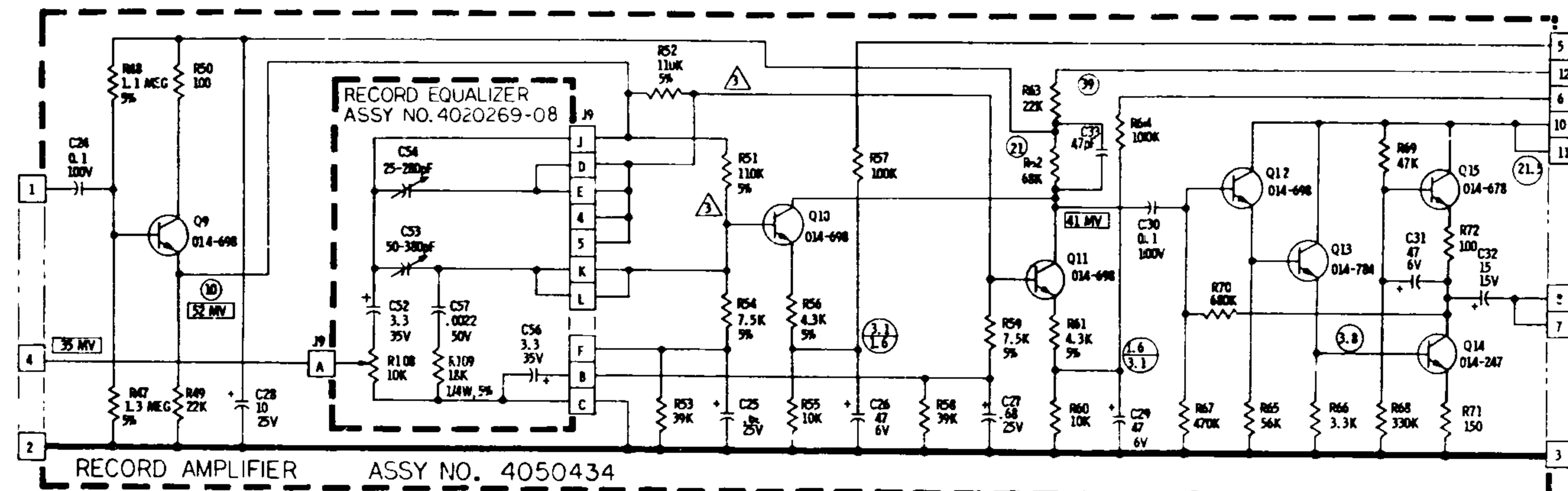

| ITEM NO. | AMPEX PART NO. | REFERENCE NUMBER | DESCRIPTION | JEDEC NO. OR MFR. PART NO. |
|----------|--------------------------|------------------|------------------------------------------------------------------------------------------------|----------------------------|
| | 4050435-12 4050435-15 | | REPRODUCE AMPLIFIER, 7.5-15 N/S (NHA 4020402) REPRODUCE AMPLIFIER, 15-30 IN/S (NHA 4020402) | |
| 1 | 4030270-02 | J2 | CONNECTOR ASSEM, 10 CONTACT | |
| 2 | 4110271-01 | | LABEL, REPRODUCE MODULE | |
| 3 | 4170337-01 | | INSULATOR, PWB | |
| 4 | 4330263-02 | | PLATE, FRONT, REPRODUCE MODULE | |
| 7 | 4580044-01 | T1 | TRANSFORMER, INPUT, 7.5-15 IN/S | |
| 9 | 4580068-01 | T1 | TRANSFORMER, INPUT, 15-30 IN/S | |
| 12 | 013-599 | CR1,2,7 | DIODE | 1N914 |
| 13 | 014-329 | Q8 | TRANSISTOR | 2N2102 |
| 15 | 014-652 | Q5 | TRANSISTOR | 2N3906 |
| 16 | 014-698 | Q2 | TRANSISTOR | 2N3565 |
| 17 | 014-706 | | HEATSINK, TRANSISTOR, REF: Q7, 8 | |
| 18 | 014-723 | Q7 | TRANSISTOR | 2N4037 |
| 19 | 014-784 | Q3,4,6 | TRANSISTOR | 2N4416 |
| 21 | 031-187 | C8 | CAPACITOR, ELEC, 50 UF, 50V, -10+75% | |
| 22 | 031-190 | C13 | CAPACITOR, ELEC, 50 UF, 25V, -10+75% | |
| 24 | 034-181 | C4,10 | CAPACITOR, MICA, 47 PF, 500V, 5% | |
| 28 | 037-446 | C6,14 | CAPACITOR, TANT, 15 UF, 15V, 20% | |
| 29 | 037-494 | C1,5 | CAPACITOR, TANT, 47 UF, 6V, 20% | |
| 30 | 037-654 | C2,3,7,11,12,17 | CAPACITOR, TANT, 3.3 UF, 35V, 20% | |
| 33 | 041-012 | R4 | RESISTOR, COMP, 4.3K, 1/2W, 5%, 15-30 IN/S | |
| 34 | 041-040 | R6 | RESISTOR, COMP, 220 OHM, 1/2W, 10% | |
| 35 | 041-043 | R27 | RESISTOR, COMP, 1K, 1/2W, 10% | |
| 36 | 041-048 | R28 | RESISTOR, COMP, 1K, 1/2W, 10% | |
| 36 | 041-048 | R26 | RESISTOR, COMP, 2.7K, 1/2W, 10%, 7.5-15 IN/S | |
| 40 | 041-053 | R29 | RESISTOR, COMP, 3.3K, 1/2W, 10% | |
| 41 | 041-054 | R10 | | |
| 42 | 041-056 | R24 | RESISTOR, COMP, 4.7K, 1/2W, 10% | |
| 43 | 041-057 | R4 | RESISTOR, COMP, 5.6K, 1/2W, 10%, 7.5-15 IN/S | |
| 44 | 041-058 | R8 | RESISTOR, COMP, 6.8K, 1/2W, 10% | |
| 46 | 041-062 | R25 | RESISTOR, COMP, 15K, 1/2W, 10% | |
| 46 | 041-062 | R5 | RESISTOR, COMP, 15K, 1/2W, 10%, 15-30 IN/S | |
| 47 | 041-067 | R2,21 | RESISTOR, COMP, 39K, 1/2W, 10% | |
| 48 | 041-069 | R22 | RESISTOR, COMP, 56K, 1/2W, 10% | |
| 49 | 041-072 | R7,23,38 | RESISTOR, COMP, 100K, 1/2W, 10% | |
| 49 | 041-072 | R3 | RESISTOR, COMP, 100K, 1/2W, 10%, 7.5-15 IN/S | |
| 50 | 041-075 | R3 | RESISTOR, COMP, 180K, 1/2W, 10%, 15-30 IN/S | |
| 51 | 041-076 | R12,13 | RESISTOR, COMP, 220K, 1/2W, 10% | |
| 52 | 041-080 | R9 | RESISTOR, COMP, 470K, 1/2W, 10% | |
| 53 | 041-081 | R18 | RESISTOR, COMP, 560K, 1/2W, 10% | |
| 56 | 041-404 | R1 | RESISTOR, COMP, 510 OHM, 1/2W, 10%, 7.5-15 IN/S | |
| 56 | 041-404 | R26 | RESISTOR, COMP, 510 OHM, 1/2W, 5%, 15-30 IN/S | |
| 57 | 041-529 | R5 | RESISTOR, COMP, 20K, 1/2W, 5%, 7.5-15 IN/S | |
| 58 | 041-533 | R30,31 | RESISTOR, COMP, 24 OHM, 1/2W, 5% | |
| 61 | 041-066 | R14,15 | RESISTOR, COMP, 33K, 1/2W, 10% | |
| 62 | 049-517 | R1 | RESISTOR, COMP, 220 OHM, 1/4W, 10%, 15-30 IN/S | |
| 63 | 058-689 | R32 | RESISTOR, VAR, 500 OHM, 10%, 15-30 IN/S | |
| 65 | 280-130 | | PAD, MTG, TRANSISTOR, REF: Q1 | |
| 66 | 280-131 | | PAD, MTG, TRANSISTOR | |
| 69 | 475-007 | | SCREW, SEM, PAN HD, NO. 4-40 X 5/16 | |
| 71 | 501-008 | | WASHER, FLAT, NO. 4 | |
| 73 | 580-135 | Q1 | TRANSISTOR | 2N4104 |
| 76 | 4840249 | | SCHEMATIC | |

AG

SHEET 1 OF 1

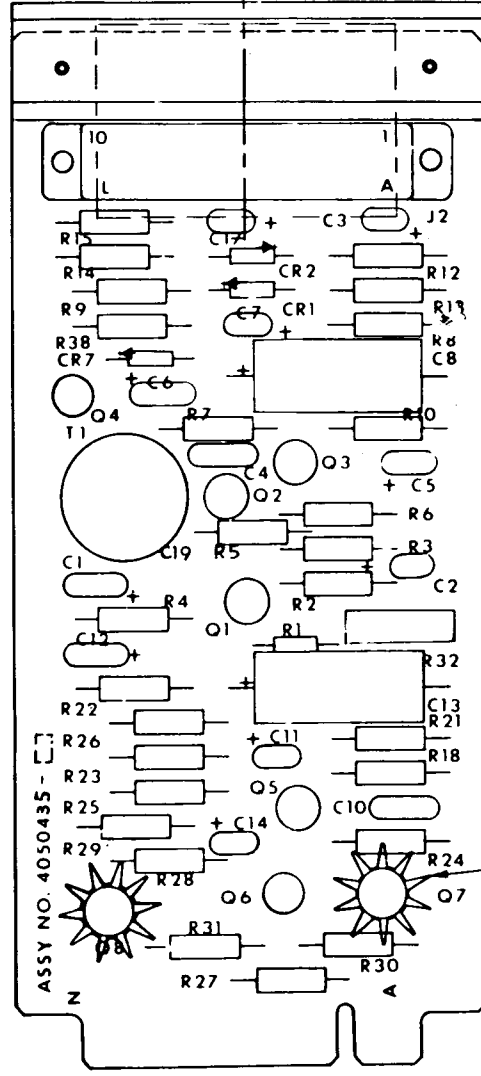
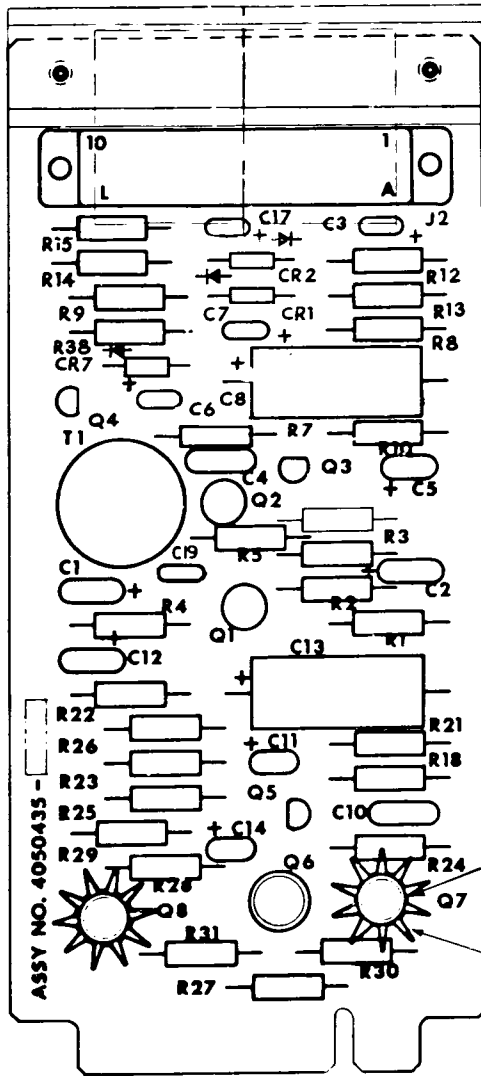

-12 SHOWN

Assembly No. 4050435. Reproduce Amplifier PWA

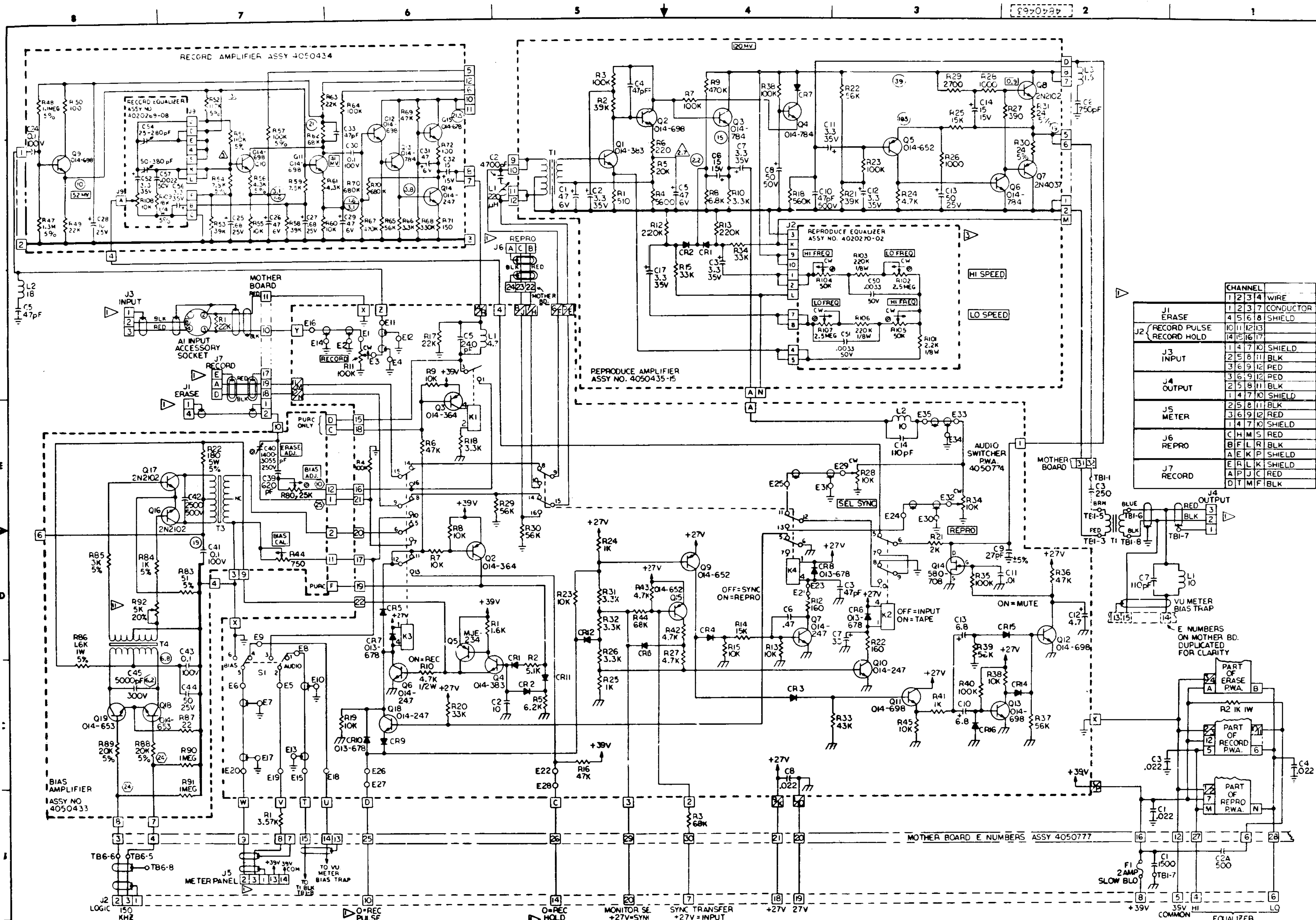

| CHANNEL | WIRE | | | |
|-----------------|------|--------|--------|-------------|
| | 1 | 2 | 3 | 4 |
| J1 ERASE | 1 | 2 | 3 | 7 CONDUCTOR |
| J2 RECORD PULSE | 4 | 5 | 6 | 8 SHIELD |
| J3 INPUT | 1 | 4 | 7 | 10 SHIELD |
| J4 OUTPUT | 2 | 5 | 8 | 11 BLK |
| J5 METER | 3 | 6 | 9 | 12 RED |
| J6 REPRO | 1 | 4 | 7 | 10 SHIELD |
| J7 RECORD | 2 | 5 | 8 | 11 BLK |
| | 3 | 6 | 9 | 12 RED |
| | 4 | 7 | 10 | SHIELD |
| | 5 | 8 | 11 | BLK |
| | 6 | 9 | 12 | RED |
| | 7 | 10 | SHIELD | |
| | 8 | 11 | BLK | |
| | 9 | 12 | RED | |
| | 10 | SHIELD | | |
| | 11 | BLK | | |
| | 12 | RED | | |

NOTES: UNLESS OTHERWISE SPECIFIED
 1. SEE WIRE CHART
 2. RESISTANCE VALUES ARE IN OHMS
 3. CAPACITANCE VALUES ARE IN MICROFARADS
 4. INDUCTOR VALUES ARE IN MILLI-HENRIES
 5. DIODES ARE PART NUMBER 013-599

| FIELD SERVICE SUB-LIST | | FIELD SER. SUB-LIST | |
|------------------------|------------|---------------------|------------|
| AMPEX P/N | VENDOR P/N | AMPEX P/N | VENDOR P/N |
| 014-383 | 2N2484 | 014-329 | 2N2012 |
| 014-364 | 2N2905A | 014-784 | 2N4946 |
| 014-652 | 2N3906 | 014-678 | 2N3945 |
| 014-247 | 2N2219 | | |
| 014-698 | 2N3565 | | |
| 580-714 | MJE 234 | | |
| 580-708 | P1086E | | |
| 014-653 | 2N3904 | | |

Schematic No. 4840463—
 Electronics Bay

| ITEM NO. | AMPEX PART NO. | REFERENCE NUMBER | DESCRIPTION | JEDEC NO. OR MFR. PART NO. |
|----------|----------------|------------------|-----------------------------------------------------------|----------------------------|
| | 4020269-01 | | RECORD EQUALIZER PWA, NAB, 7.5-15 IN/S (NHA 4010240) | |
| | 4020269-03 | | RECORD EQUALIZER PWA, CCIR/IEC, 7.5-15 IN/S (NHA 4010240) | |
| | 4020269-06 | | RECORD EQUALIZER PWA, CCIR/IEC, 15-30 IN/S (NHA 4010240) | |
| | 4020269-08 | | RECORD EQUALIZER PWA, NAB, 15-30 IN/S (NHA 4010240) | |
| 3 | 4540314-02 | C54 | CAPACITOR, TRIMMER, 50-380 PF, 7.5-15 IN/S | |
| 4 | 4540314-03 | C53 | CAPACITOR, TRIMMER, 170-780 PF, 7.5-15 IN/S | |
| 7 | 037-654 | C52 | CAPACITOR, TANT, 3.3 UF, 35V, 20% | |
| 8 | 037-654 | C55,56 | CAPACITOR, TANT, 3.3 UF, 35V, 20%. CCIR/IEC | |
| 10 | 055-164 | C57 | CAPACITOR, MYLAR, 0.0022UF, 50V, 10%, NAB | |
| 11 | 041-436 | R109 | RESISTOR, COMP, 18K, 1/4W, 5%, NAB | |
| 12 | 037-654 | C56 | CAPACITOR, TANT, 3.3 UF, 35V, 20%, NAB, 15-30 IN/S | |
| 13 | 4540314-01 | C54 | CAPACITOR, TRIMMER, 25-280 PF, CCIR/IEC, NAB | |
| 14 | 4540314-02 | C53 | CAPACITOR, TRIMMER, 50-380 PF, CCIR/IEC, NAB | |
| 18 | 4520153-07 | R108 | POTENTIOMETER, 10K, RECORD CALIBRATION | |
| 20 | 4840330 | | SCHEMATIC, 7.5-15 IN/S | |
| 23 | 4840372 | | SCHEMATIC, 15-30 IN/S | |

SHEET 1 OF 1

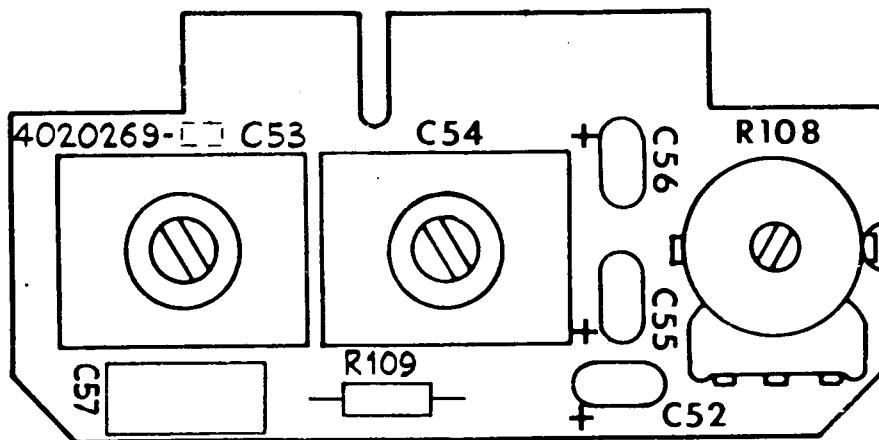

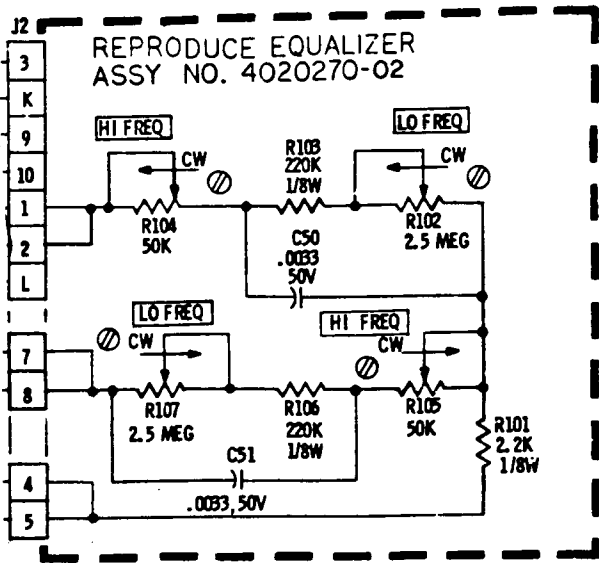

HI SPEED

LO SPEED

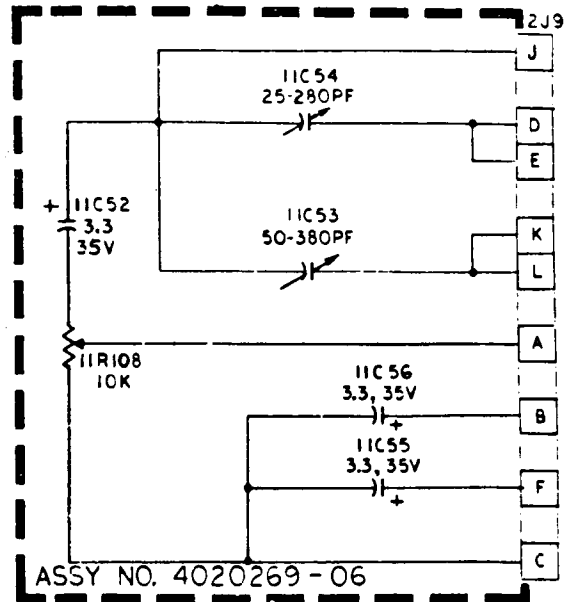

15 IPS CCIR
30 IPS 17.5 US
(RECORD EQUALIZER)

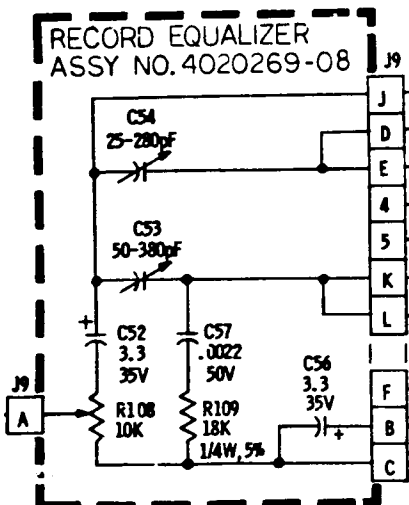

NOTES: UNLESS OTHERWISE SPECIFIED

1. CAPACITANCE VALUES ARE IN MICROFARADS

2. DIODES ARE TYPE 013-599.

3. REPRODUCE EQUALIZER 4020270-02 CAN BE ADJUSTED TO NAB AND/OR CCIR.

4. RESISTANCE VALUES ARE IN OHMS 1/2W, 10%.

10. FIELD SERVICE COMPONENT SUBSTITUTION:

| REF. DES. | AMPEX P/N | NEAREST COML EQUIVALENT |
|---------------|-----------|-------------------------|
| CR1, CR2, CR7 | 013-599 | 1N914 |
| Q14 | 014-247 | 2N2219 |
| Q5 | 014-652 | 2N3906 |
| Q18, Q19 | 014-653 | 2N3904 |
| Q15 | 014-678 | NONE |
| Q2, Q9-12 | 014-698 | NONE |
| Q3, 4, 13, 6 | 014-784 | NONE |
| Q1 | 014-393 | 2N4104 |

Schematic No. 4840372F. Record/Reproduce Equalizer PWA's, 15 - 30 In/S

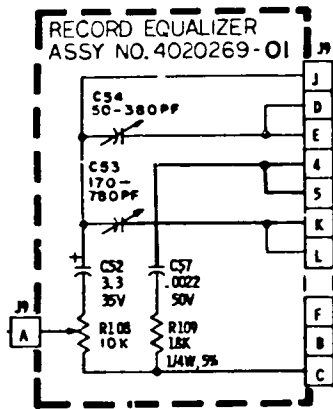
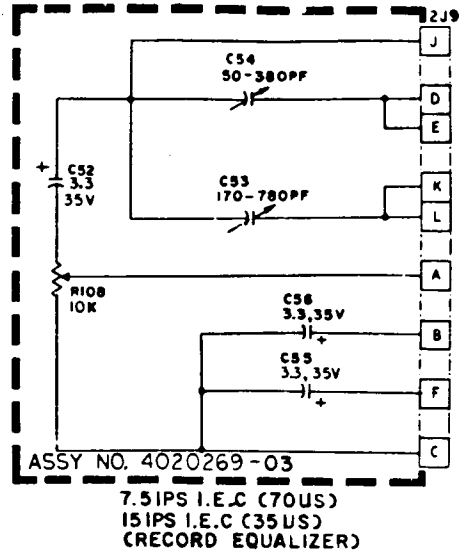
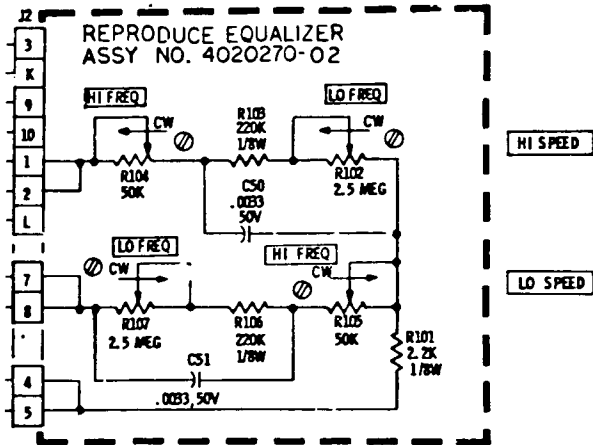

NOTES UNLESS OTHERWISE SPECIFIED

1. CAPACITANCE VALUES ARE IN MICROFARADS
2. DIODES ARE TYPE 013-599.
3. REPRODUCE EQUALIZER 4020270-02 CAN BE ADJUSTED TO NAB AND/OR CCIR.
4. RESISTANCE VALUES ARE IN OHMS 1/2W, 10%.

10. FIELD SERVICE COMPONENT SUBSTITUTION :

| REF. DES. | AMPEX P/N | NEAREST COML. EQUIVALENT |
|---------------|-----------|--------------------------|
| CR1, CR2, CR7 | 013-599 | 1N914 |
| Q14 | 014-267 | 2N2219 |
| Q5 | 014-652 | 2N3906 |
| Q18, Q19 | 014-653 | 2N3904 |
| Q15 | 014-678 | NONE |
| Q2, Q9-12 | 014-698 | NONE |
| Q3, 4, 13, 6 | 014-784 | NONE |
| Q1 | 014-383 | 2N4104 |

Schematic No. 4840330C. Record/Reproduce Equalizer PWA's, 7-1/2 - 15 In/S

| ITEM NO. | AMPEX PART NO. | REFERENCE NUMBER | DESCRIPTION | JEDEC NO. OR MFR. PART NO. |
|----------|----------------|------------------|---------------------------------------|----------------------------|
| | 4020270-02 | | REPRODUCE EQUALIZER PWA (NHA 4010240) | |
| 2 | 4520152-01 | R104,105 | POTENTIOMETER, 50K | |
| 3 | 4520152-02 | R102,107 | POTENTIOMETER, 2.5M | |
| 4 | 049-528 | R103,106 | RESISTOR, COMP, 220K, 1/8W, 10% | |
| 5 | 049-527 | R101 | RESISTOR, COMP, 2.2K, 1/8W, 10% | |
| 8 | 055-889 | C50,51 | CAPACITOR, MYLAR, 0.0033 UF, 100V, 5% | |
| 12 | 4840330 | | SCHEMATIC, 7.5-15 IPS | |
| 13 | 4840372 | | SCHEMATIC, 15-30 IPS | D |

SHEET 1 OF 1

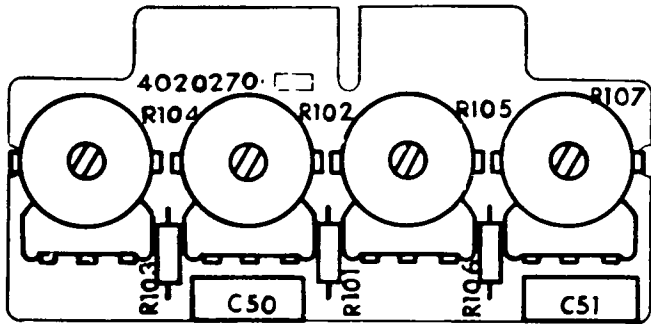

| ITEM NO. | AMPEX PART NO. | REFERENCE NUMBER | DESCRIPTION | JEDEC NO. OR MFR. PART NO. |
|----------|----------------|------------------|---------------------------------------------------------|----------------------------|
| | 4050765-02 | | REAR PANEL ASSEMBLY (NHA 4020402) | |
| 2 | 4050777-02 | | MOTHERBOARD PWA | |
| 3 | 4050767-01 | | REAR PANEL HARNESS ASSEMBLY | |
| 5 | 4290781-02 | | PANEL, REAR, ELECTRONICS | |
| 7 | 4290792-01 | | SHIELD, PWB | |
| 8 | 034-260 | C7-10 | CAPACITOR, MICA, 110 PF, 500V, 1% | |
| 9 | 540-055 | L1-4 | INDUCTOR, FIXED, 10 MH, 10% | |
| 10 | 4580193-01 | T1-4 | TRANSFORMER, OUTPUT | |
| 11 | 4840408 | | INTERCONNECT DIAGRAM | |
| 13 | 031-126 | C3-6 | CAPACITOR, ALUM, 250 UF, 50V, -10+150% | |
| 14 | 031-179 | C1 | CAPACITOR, ALUM, ELECT, SLEEVED, 1500 UF, 50V, -10+150% | |
| 15 | 041-406 | R1-4 | RESISTOR, COMP, 22K, 1/4W, 5% | |
| 16 | 063-191 | C2 | CAPACITOR, QUAD, ALUM, 500 UF, | |
| 17 | 070-019 | F1 | FUSE, SLO-BLO, 125V, 2 AMP | |
| 18 | 085-001 | | FUSEHOLDER | |
| 19 | 280-431 | | SPACER, THREADED, SWAGE, NO. 4-40 X 0.188 LG | |
| 20 | 150-023 | | SOCKET, 8 PIN | |
| 21 | 166-867 | J6 | BODY, CONNECTOR, RECT, 18 SOCKET | |
| 22 | 169-083 | J7 | BODY, CONNECTOR, RECT, 20 SOCKET | |
| 23 | 280-469 | | SPACER, HEX, 0.25 A, FLATS, NO. 4-40 X 0.188 LG | |
| 24 | 180-039 | | TERMINAL STRIP | |
| 25 | 302-335 | | STRAP, CABLE | |
| 26 | 301-004 | | CLAMP, CAPACITOR, 1 1/2 IN, REF: C2 | |
| 27 | 302-395 | | STRAP, CABLE | |
| 28 | 471-065 | | SCREW, PAN HD, XREC, NO. 4-40 X 5/8 LG | |
| 29 | 471-068 | | SCREW, PAN HD, XREC, NO. 6-32 X 0.312 LG | |
| 30 | 471-071 | | SCREW, PAN HD, XREC, NO. 6-32 X 0.50 LG | |
| 32 | 496-005 | | NUT, KEP, NO. 6-32 | |
| 33 | 498-267 | | NUT, WING, NO. 4-40 | |
| 34 | 501-008 | | WASHER, PLAIN, NO. 4 | |
| 35 | 496-004 | | NUT, KEP, NO. 4 | |
| 36 | 501-186 | | WASHER, PLAIN, SMALL PAT, 0.209 OD, NO. 4 | |
| 37 | 502-002 | | WASHER, LOCK, HELICAL, NO. 4 | |
| 42 | 492-034 | | NUT, HEX, SM PAT, NO. 6-32 | |
| 45 | 502-025 | | WASHER, LOCK, INT TOOTH, NO. 6 | |
| 46 | 502-091 | | WASHER | |
| 48 | 501-009 | | WASHER, PLAIN, NO. 6 | |
| 56 | 301-130 | | CLAMP, CAPACITOR, 1.375 DIA, REF: C1 | |
| 57 | 471-072 | | SCREW, PAN HD, XREC, NO. 6-32 X 0.63 LG | |

E

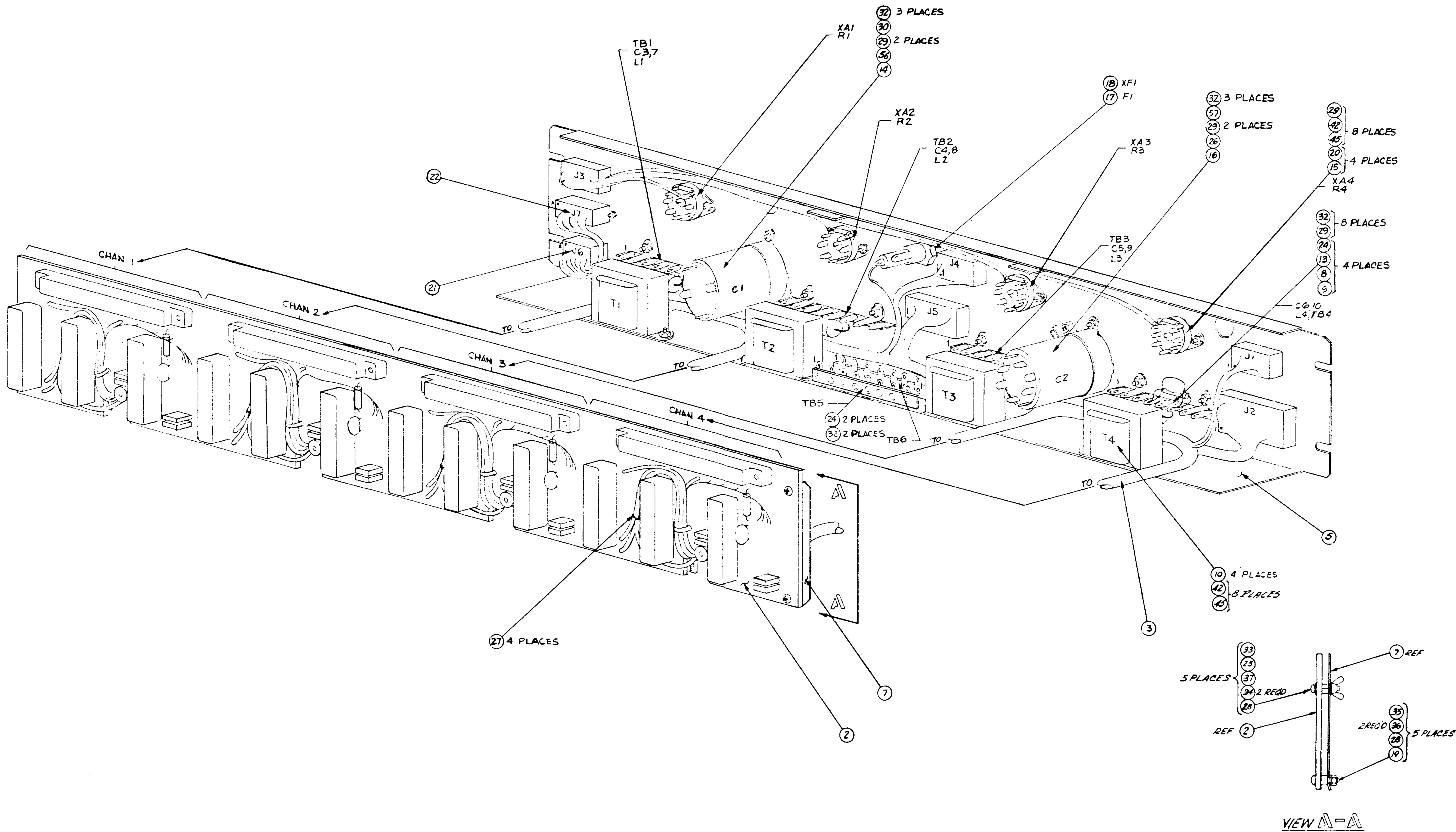

Assembly No. 4050765.
Rear Panel Assembly

| ITEM NO. | AMPEX PART NO. | REFERENCE NUMBER | DESCRIPTION | JEDEC NO. OR MFR. PART NO. |
|----------|----------------|------------------|-------------------------------------------|----------------------------|
| | 4050767-01 | | REAR PANEL HARNESS ASSEMBLY (NHA 4050765) | |
| 1 | 166-199 | | CONTACT, SOC, 22-20 AWG | |
| 2 | 166-200 | | CONTACT, PIN, 22-20 AWG | |
| 3 | 166-224 | | CONTACT, SOC, 24-26 AWG | |
| 4 | 166-226 | | CONTACT, PIN, 26-24 AWG | |
| 5 | 169-076 | | CONTACT, SOC, 22-20 AWG | |
| 8 | 167-025 | J1,3,4 | BODY, CONNECTOR, RECT, RECPT, 12 POS | |
| 9 | 167-027 | J5 | BODY, CONNECTOR, RECT, RECPT, 24 POS | |
| 10 | 167-029 | J2 | BODY, CONNECTOR, RECT, RECPT, 36 POS | |
| 13 | 302-335 | | STRAP, CABLE | |
| 36 | 4840408 | | INTERCONNECT DIAGRAM | |

C

| ITEM NO. | AMPEX PART NO. | REFERENCE NUMBER | DESCRIPTION | JEDEC NO. OR MFR. PART NO. |
|----------|----------------|-----------------------------|---------------------------------------|----------------------------|
| | 4050777-02 | | MOTHERBOARD PWA (NHA 4050765) | |
| 6 | 035-730 | 1C2-4C2 | CAPACITOR, MYLAR, 50V, 4700 PF, 5% | |
| 7 | 035-828 | 1C1-4C1,1C3-4C3, 1C4-4C4 | CAPACITOR, MYLAR, 50V, 0.022 UF, 5% | |
| 9 | 034-330 | 1C6-4C6 | CAPACITOR, MICA, 750 PF, 500V, 1% | |
| 10 | 041-102 | 1R2-4R2 | RESISTOR, COMP, 1K, 1W, 5% | |
| 11 | 041-415 | 1R3-4R3 | RESISTOR, COMP, 68K, 1/4W, 5% | |
| 13 | 057-759 | 1R1-4R1 | RESISTOR, MF, 3.57K, 1/2W, 1% | |
| 16 | 4630052-01 | 1J2-4J2,1J3-4J3, 1J4-4J4 | CONNECTOR, PC, RECP, 12 DUAL CONTACT | |
| 17 | 139-795 | 1J1-4J1 | CONNECTOR, PC, RECP, 22 DUAL CONTACT | |
| 18 | 169-818 | | KEY, POLARIZING | |
| 20 | 541-133 | 1L1-4L1 | INDUCTOR, VAR, 220 UH | |
| 21 | 540-074 | 1L3-4L3 | INDUCTOR, FIXED, 1.5 MH, 10% | |
| 22 | 051-744 | 1L2-4L2 | INDUCTOR, FIXED, 18 MH, 10% | |
| 23 | 056-601 | 1C5-4C5 | CAPACITOR, MICA, 47 PF, 500V, ±0.5 PF | |
| 36 | 4840391 | | SCHEMATIC | |

D

SHEET 1 OF 1

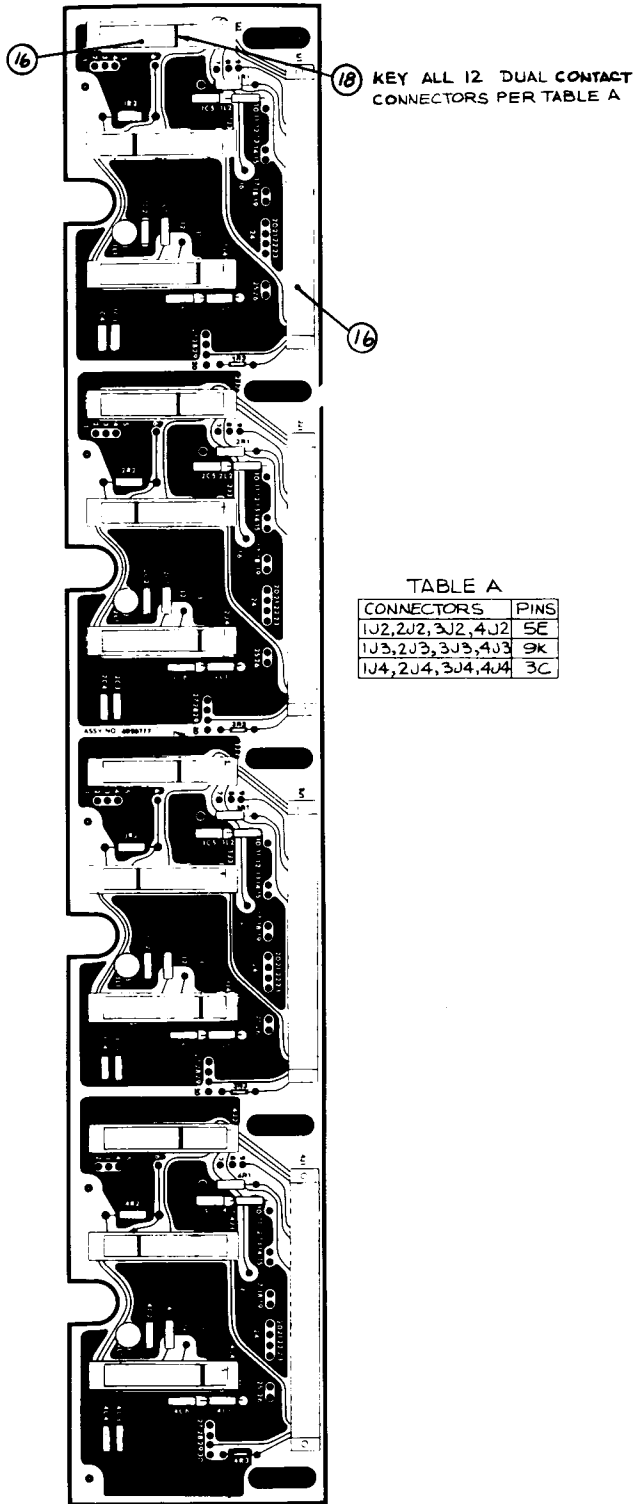

Assembly No. 4050777. Motherboard PWA

AUDIO SWITCHING
4050774

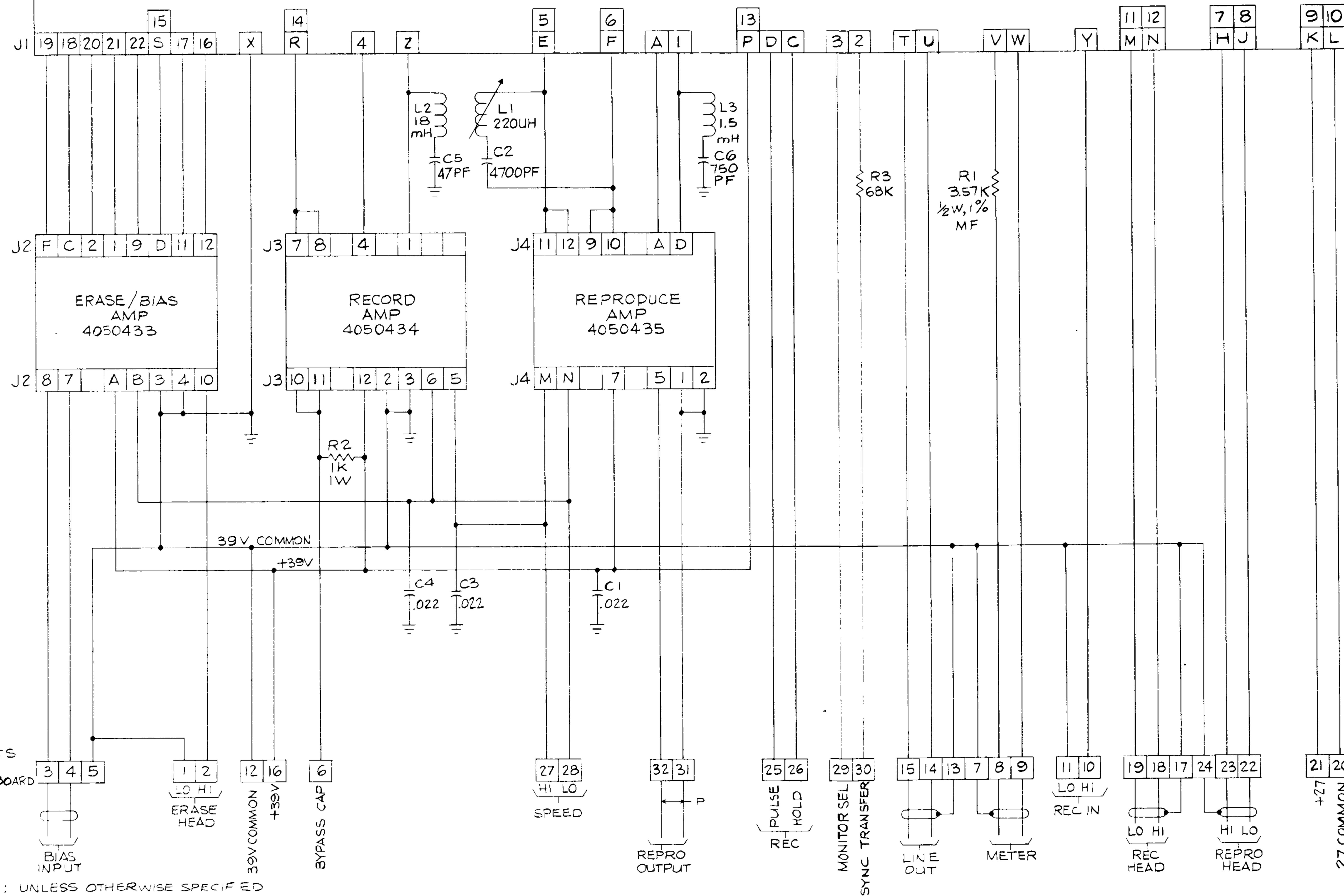

'E' POINTS ON MOTHERBOARD

3 4 5

1 2

LO HI

ERASE HEAD

12 16

39V COMMON

+39V

6

BIAS INPUT

39V COMMON

BYPASS CAP

27 28

HI LO

SPEED

32 31

P

REPRO OUTPUT

25 26

PULSE HOLD

REC

29 30

MONITOR SEL

SYNC TRANSFER

15 14 13

7 8 9

LINE OUT

METER

11 10

LO HI

REC IN

19 18 17

24 23 22

LO HI

REC HEAD

HI LO

REPRO HEAD

21 20

+27

27 COMMON

- NOTES: UNLESS OTHERWISE SPECIFIED
1. CAPACITOR VALUES IN MICROFARADS, 50V, 5%
 2. RESISTOR VALUES IN OHMS, 1/4W, 5%
 3. THE MOTHERBOARD HAS 4 CHANNELS WITH PREFIXES ON COMPONENTS TO IDENTIFY EACH CHANNEL IE: 1J1, 2J1, 3J1, 4J1 ETC.
 4. P.W.A. NO. IS 4050777-02, REV D.

Schematic No. 4840391B.
Motherboard PWA

| ITEM NO. | AMPEX PART NO. | REFERENCE NUMBER | DESCRIPTION | JEDEC NO. OR MFR. PART NO. |
|----------|----------------|--------------------------------|------------------------------------------------|----------------------------|
| | 4050774-03 | | AUDIO SWITCHING PWA (NHA 4020402) | |
| 3 | 4120024-01 | | HANDLE, SWITCHER BOARD | |
| 4 | 4170318-01 | | LABEL, HANDLE | |
| 9 | 013-703 | VR1 | DIODE | 1N968B |
| 11 | 013-599 | CR1-4,9,11,16 | DIODE | 1N914 |
| 12 | 013-678 | CR5-8,10 | DIODE | 1N4005 |
| 15 | 014-247 | Q6,7,8,10 | TRANSISTOR | 2N2219 |
| 16 | 014-364 | Q2,3 | TRANSISTOR | 2N2905A |
| 17 | 014-383 | Q4 | TRANSISTOR | 2N2484 |
| 18 | 014-652 | Q9,15 | TRANSISTOR | 2N3906 |
| 19 | 014-698 | Q11,12,13 | TRANSISTOR | 2N3565 |
| 22 | 034-543 | C5 | CAPACITOR, MICA 240 PF, 500V, 1% | |
| 24 | 034-938 | C14 | CAPACITOR, MICA, 110 PF, 500V, 5% | |
| 26 | 035-828 | C1,8 | CAPACITOR, MYLAR, 0.022 UF, 50V, 5% | |
| 28 | 037-591 | C6 | CAPACITOR, TANT, 1 UF, 35V, 20% | |
| 29 | 037-908 | C12 | CAPACITOR, TANT, 4.7 UF, 35V, 20% | |
| 30 | 037-933 | C3,4 | CAPACITOR, TANT, 10 UF, 35V, 20% | |
| 31 | 037-931 | C10,13 | CAPACITOR, TANT, 6.8 UF, 35V, 20% | |
| 32 | 037-429 | C7 | CAPACITOR, TANT, 33 UF, 35V, 10% | |
| 33 | 037-980 | C2 | CAPACITOR, TANT, 10 UF, 50V, 10% | |
| 36 | 041-013 | R10 | RESISTOR, COMP, 4.7K, 1/2W, 5% | |
| 37 | 041-394 | R4,35,40 | RESISTOR, COMP, 100K, 1/4W, 5% | |
| 38 | 041-406 | R17 | RESISTOR, COMP, 22K, 1/4W, 5% | |
| 39 | 041-407 | R18,26,31,32 | RESISTOR, COMP, 3.3K, 1/4W, 5% | |
| 40 | 041-408 | R2,5,8,9,13,15,19, 23,38,45 | RESISTOR, COMP, 10K, 1/4W, 5% | |
| 41 | 041-410 | R14,24,25,41 | RESISTOR, COMP, 1K, 1/4W, 5% | |
| 42 | 041-411 | R6,7,16,36,33 | RESISTOR, COMP, 47K, 1/4W, 5% | |
| 44 | 041-412 | R27,42,43 | RESISTOR, COMP, 4.7K, 1/4W, 5% | |
| 45 | 041-415 | R44 | RESISTOR, COMP, 68K, 1/4W, 5% | |
| 47 | 041-437 | R1 | RESISTOR, COMP, 1.6K, 1/4W, 5% | |
| 48 | 041-518 | R20 | RESISTOR, COMP, 33K, 1/4W, 5% | |
| 50 | 041-519 | R29,30,37,39 | RESISTOR, COMP, 56K, 1/4W, 5% | |
| 51 | 041-560 | R21 | RESISTOR, COMP, 2K, 1/4W, 5% | |
| 52 | 041-738 | R12,22 | RESISTOR, COMP, 160 OHM, 1/4W, 5% | |
| 55 | 051-360 | L1 | INDUCTOR, FIXED, 4.7 MH | |
| 56 | 051-952 | L2 | INDUCTOR, 10 MH, 5% | |
| 63 | 064-116 | C11 | CAPACITOR, CER, 0.01 UF, 50V, +80-20% | |
| 64 | 119-343 | S1 | SWITCH, DPDT | |
| 65 | 075-119 | R11 | RESISTOR, VAR, 100K, 1/2W, 20% | |
| 66 | 075-120 | R28,34 | RESISTOR, VAR, 10K, 1/2W, 20% | |
| 67 | 020-853 | | SOCKET, RELAY, W/RET SPRING, REF: K2, 3, 4 | |
| 68 | 020-851 | K2,3,4 | RELAY, ARMATURE, 4 PDT, FORM D | |
| 69 | 020-592 | K1 | RELAY, REED, SPST | |
| 71 | 302-335 | | STRAP, CABLE | |
| 72 | 280-130 | | PAD, MTG, TRANSISTOR, T0-18, REF: Q4,9,11-15 | |
| 73 | 280-998 | | PAD, MTG, TRANSISTOR, T0-5, REF: Q2,3,6,7,8,10 | |
| 75 | 475-014 | | SCREW, SEM, PAN HD, NO. 6-32 X 1/4 INCH | |
| 76 | 501-009 | | WASHER, FLAT, NO. 6 | |
| 79 | 580-714 | Q5 | TRANSISTOR | MJE 234 |
| 80 | 580-708 | Q14 | TRANSISTOR | P1086E |
| 82 | 4840388 | | SCHEMATIC | |

F

SHEET 1 OF 1

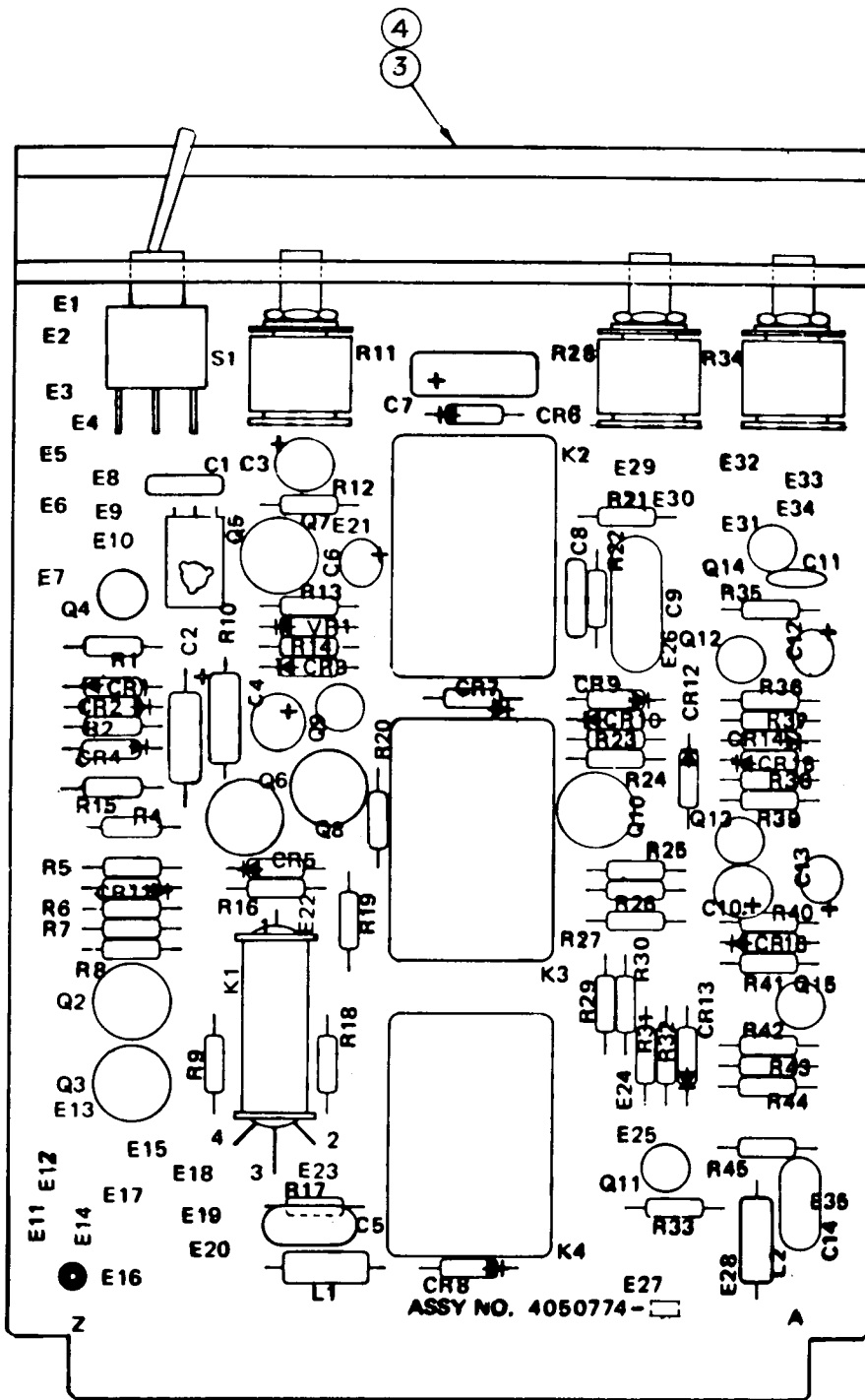

Assembly No. 4050774. Audio Switching PWA

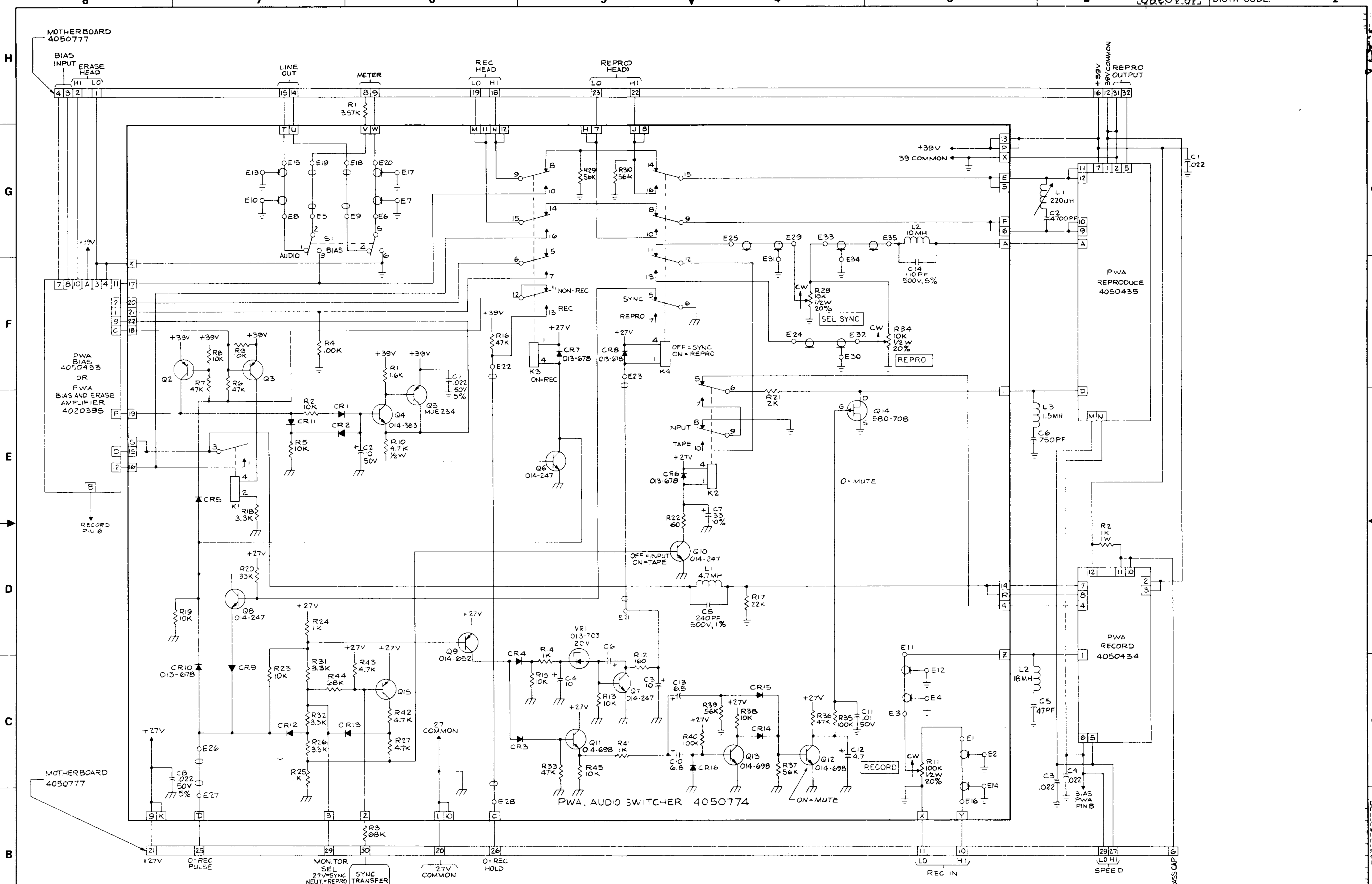

NOTES: UNLESS OTHERWISE SPECIFIED
 1 CAPACITANCE VALUES ARE IN MICROFARADS, 35V, 20%
 2 RESISTANCE VALUES ARE IN OHMS, 1/4W, 5%
 3 DIODES ARE 013-599
 4 P.W.A. NO. IS 4050774-02 REV E.

| REFERENCE DESIGNATIONS | |
|------------------------|----------|
| LAST USED | NOT USED |
| C14 | C9 |
| CR16 | CR12 |
| E35 | |
| K4 | |
| L2 | |
| Q15 | |
| R45 | |
| S1 | |
| VR1 | |

Schematic No. 4840388C.
 Audio Switching PWA

| ITEM NO. | AMPEX PART NO. | REFERENCE NUMBER | DESCRIPTION | JEDEC NO. OR MFR. PART NO. |
|----------|--------------------------|------------------|-----------------------------------------------------------------------------------------------------------------------------|----------------------------|
| | 4020334-03 4020334-04 | | ONE-INCH HEAD ASSEMBLY, 8 CHANNEL, 15-30 IN/S (NHA 4010240) ONE-INCH HEAD ASSEMBLY, 8 CHANNEL, 7.5-15 IN/S (NHA 4010240) | |
| 3 | 4120070-01 | | HANDLE, LIFTER, HEAD PLATE | |
| 4 | 4200190-02 | | BUSHING, LIFTER, HEAD PLATE | |
| 7 | 4330307-04 | | PLATE, MTG. HEAD | |
| 8 | 4350178-01 | | RECORD/REPRODUCE HEAD STACK ASSY | |
| 9 | 4350180-01 | | SHIELD, CAN, 1 INCH, LEFT HAND | |
| 10 | 4350180-02 | | SHIELD, CAN, 1 INCH, RIGHT HAND | |
| 15 | 4952316-01 | | BLOCK, HINGE, COVER, HEAD SHIELD | |
| 16 | 4952408-01 | | GUIDE, TAKEUP | |
| 18 | 4041048-05 | | SCRAPE FLUTTER IDLER ASSEMBLY, 1 INCH | |
| 21 | 1232483-02 | | ERASE HEADSTACK ASSY | |
| 22 | 4350178-02 | | REPRODUCE HEADSTACK ASSY, 7.5-15 IN/S | |
| 26 | 352-247 | | SPRING, EXT, 0.125 OD X 1.500 LG | |
| 27 | 250-007 | | BUMPER, RUBBER | |
| 28 | 470-002 | | SCREW, CAP HD, HEX SOC, NO. 2-56 X 0.25 LG | |
| 31 | 470-024 | | SCREW, CAP HD, HEX SOC, NO. 6-32 X 1.00 LG | |
| 32 | 470-171 | | SCREW, CAP HD, HEX SOC, NO. 4-40 X 1.00 LG | |
| 33 | 471-411 | | SCREW, FLAT HD, XREC, NO. 10-32 X 1.00 LG | |
| 35 | 471-803 | | SCREW, BIND HD, SLOTTED, NO. 2-56 X 1.00 LG | |
| 36 | 471-074 | | SCREW, PAN HD, XREC, NO. 6-32 X 0.87 LG | |
| 39 | 477-613 | | SCREW, SET, HEX SOC, NO. 6-32 X 0.188 LG | |
| 40 | 496-006 | | NUT, KEP, NO. 8-32 | |
| 41 | 492-015 | | NUT, PLAIN, NO. 6-32 | |
| 43 | 493-168 | | NUT, SELF LOCKING, NO. 2-56 | |
| 44 | 501-009 | | WASHER, PLAIN, NO. 6 | |
| 45 | 501-184 | | WASHER, PLAIN, NO. 2 | |
| 46 | 502-002 | | WASHER, LOCK, SPRING, NO. 4 | |
| 47 | 502-003 | | WASHER, LOCK, SPRING, NO. 6 | |
| 48 | 501-009 | | WASHER, PLAIN, NO. 8 | |
| 50 | 4030386-01 | | HEAD GATE ASSEMBLY, 1 INCH | |
| 51 | 4120026-01 | | CLIP, HEAD ASSEMBLY | |
| 52 | 4350208-02 | | COVER, HEAD ASSEMBLY | |

K

SHEET 1 OF 1

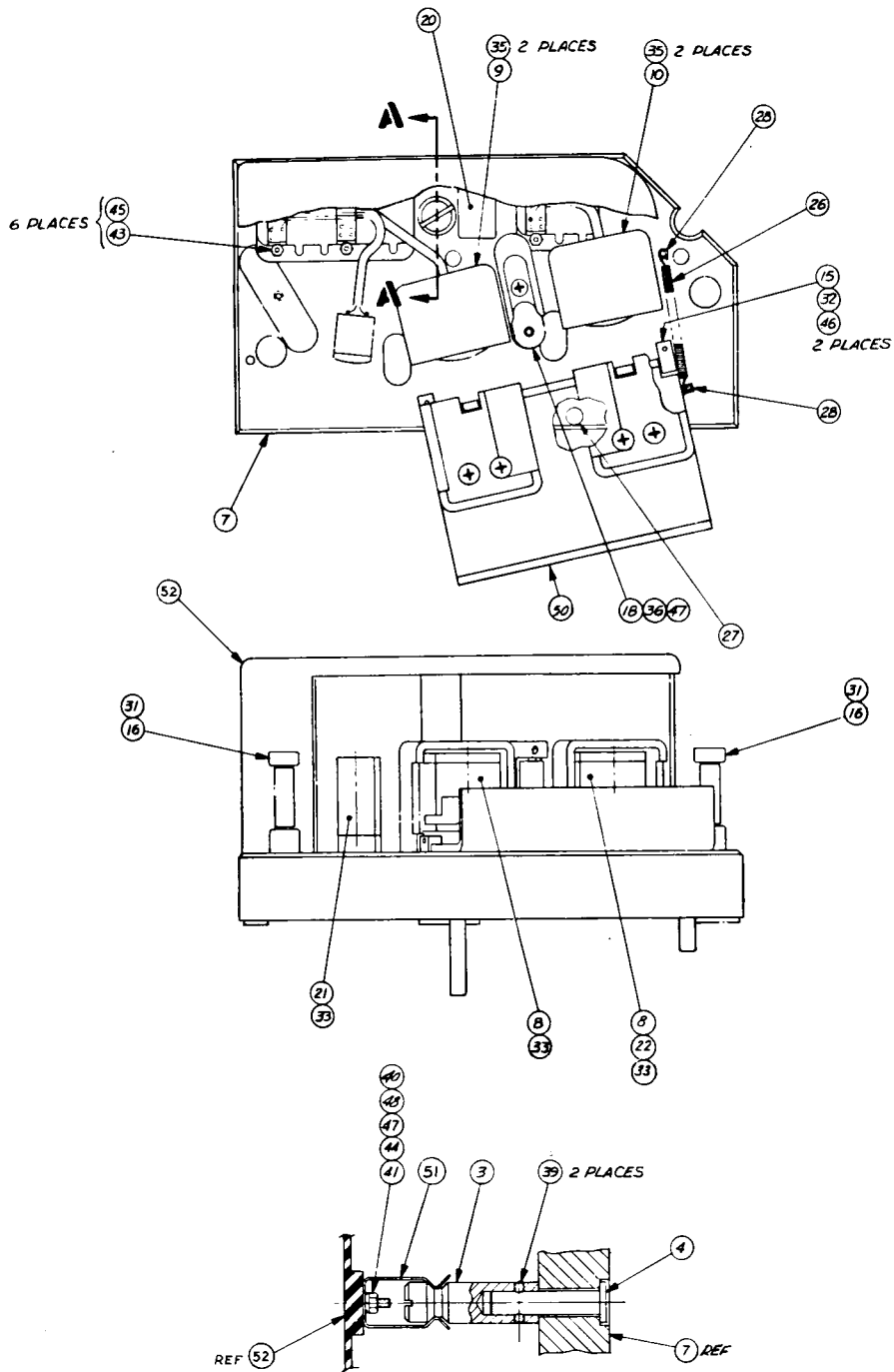

SECTION **A-A**

Assembly No. 4020334. One-Inch Head Assembly, 8-Channel

| ITEM NO. | AMPEX PART NO. | REFERENCE NUMBER | DESCRIPTION | JEDEC NO. OR MFR. PART NO. |
|----------|--------------------------|------------------|------------------------------------------------------------------------------------------|----------------------------|
| | 4030386-01 4030386-02 | | HEAD GATE ASSEMBLY, ONE-INCH (NHA 4020334) HEAD GATE ASSEMBLY, TWO-INCH (NHA 4020372) | |
| 1 | 4041201-01 | | BRACKET, COVER, HEAD SHIELD, 1 INCH | |
| 2 | 4041201-02 | | BRACKET, COVER, HEAD SHIELD, 2 INCH | |
| 3 | 4270257-01 | | SPRING, LEAF | |
| 4 | 4350181-01 | | COVER, SHIELD, 1 INCH | |
| 5 | 4350181-02 | | COVER, SHIELD, 1 INCH | |
| 6 | 4952400-06 | | COVER, SHIELD, 2 INCH | |
| 7 | 4952400-07 | | COVER, SHIELD, 2 INCH | |
| 8 | 473-752 | | SCREW, FLAT HD, 82°, XREC, NYLON THD, LOCK, NO. 6-32 X 0.438 LG | |

SHEET 1 OF 1

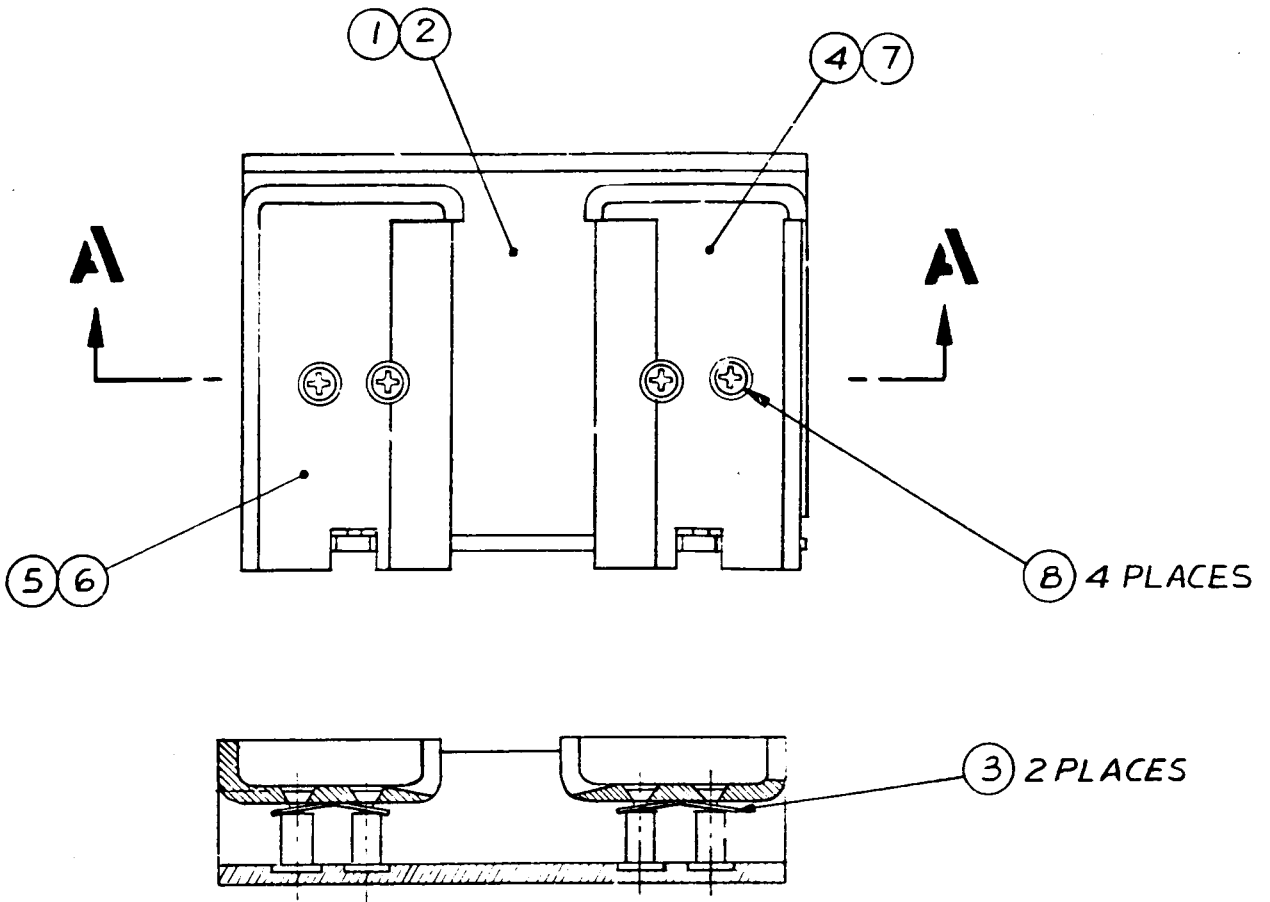

SECTION A-A

| ITEM NO. | AMPEX PART NO. | REFERENCE NUMBER | DESCRIPTION | JEDEC NO. OR MFR. PART NO. |
|----------|----------------|------------------|-------------------------------------------------------|----------------------------|
| | 4041048-05 | | SCRAPE FLUTTER IDLER ASSEMBLY, ONE-INCH (NHA 4020334) | |
| 1 | 4040953-01 | | HOLDER ASSY | |
| 5 | 087-239 | | LUBRICANT, OIL, SYNTHETIC, INSTRUMENT | |
| 6 | 477-215 | | SCREW, SET, CUT POINT, NO. 2-56 X 1/8 LG | |
| 10 | 4230130-03 | | YOKE, SCRAPE FLUTTER | |
| 11 | 4250073-03 | | IDLER, SCRAPE FLUTTER, 1 INCH | C |

SHEET 1 OF 1

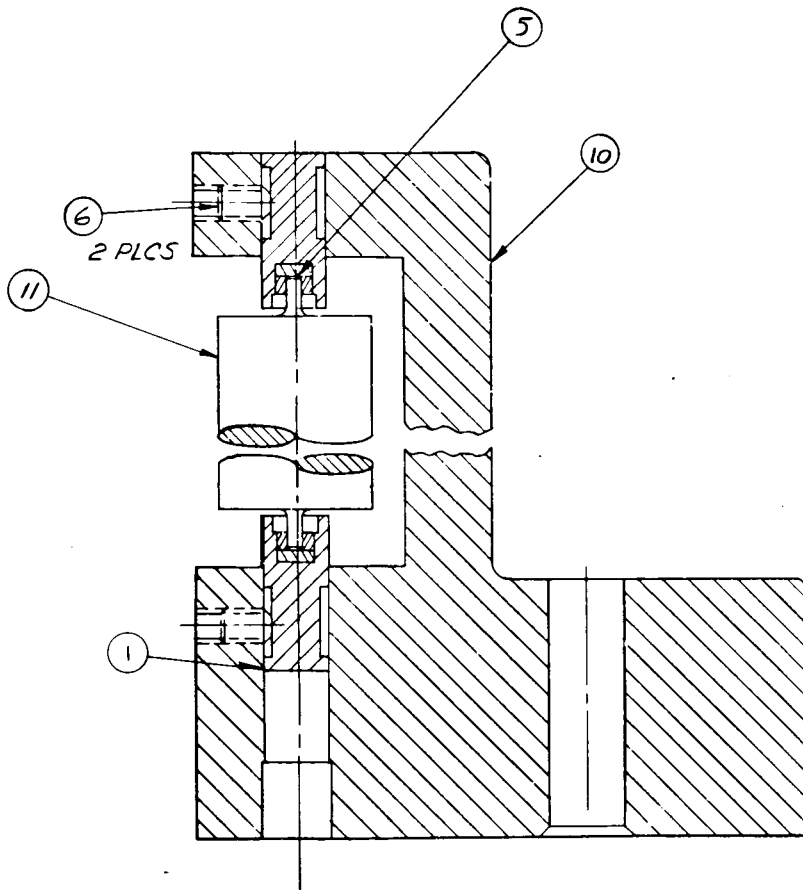

| ITEM NO. | AMPEX PART NO. | REFERENCE NUMBER | DESCRIPTION | JEDEC NO. OR MFR. PART NO. |
|----------|----------------|------------------|---------------------------------------------------------------|----------------------------|
| | 4020372-05 | | TWO-INCH HEAD ASSEMBLY, 16 CHANNEL, 15-30 IN/S (NHA 4010240) | |
| | 4020372-06 | | TWO-INCH HEAD ASSEMBLY, 24 CHANNEL, 15-30 IN/S (NHA 4010240) | |
| | 4020372-07 | | TWO-INCH HEAD ASSEMBLY, 16 CHANNEL, 7.5-15 IN/S (NHA 4010240) | |
| | 4020372-08 | | TWO-INCH HEAD ASSEMBLY, 24 CHANNEL, 7.5-15 IN/S (NHA 4010240) | |
| 2 | 4120070-01 | | HANDLE, LIFTER, HEAD PLATE | |
| 5 | 4330307-03 | | PLATE, MTG, HEAD | |
| 6 | 4200190-01 | | BUSHING, LIFTER, HEAD PLATE | |
| 7 | 4350315-01 | | REPRODUCE HEAD STACK ASSY, 16 CHANNEL | |
| 8 | 4350101-02 | | ERASE HEAD STACK ASSY, 16 CHANNEL | |
| 9 | 4350311-01 | | RECORD/REPRODUCE HEAD STACK ASSY, 16 CHANNEL | |
| 10 | 4350224-04 | | REPRODUCE HEAD STACK ASSY, 24 CHANNEL | |
| 11 | 4350224-03 | | RECORD/REPRODUCE, HEAD STACK ASSY, 24 CHANNEL | |
| 12 | 4350329-01 | | ERASE HEAD STACK ASSY, 24 CHANNEL | |
| 13 | 4952316-01 | | BLOCK, HINGE, COVER, HEAD SHIELD | |
| 14 | 4952399-03 | | SHIELD, CAN, 2 IN, LEFT HAND | |
| 15 | 4952399-04 | | SHIELD, CAN, 2 IN, RIGHT HAND | |
| 18 | 4952408-02 | | GUIDE, TAKEUP | |
| 20 | 4952442-02 | | SCRAPE FLUTTER IDLER ASSEMBLY, 2-INCH | |
| 23 | 352-247 | | SPRING, EXT, 0.125 OD X 1.500 LG | |
| 24 | 477-613 | | SCREW, SET, HEX SOC, NO. 6-32 X 0.188 LG | |
| 26 | 470-004 | | SCREW, CAP HD, HEX SOC, NO. 2-56 X 0.37 LG | |
| 27 | 470-013 | | SCREW, CAP HD, HEX SOC, NO. 4-40 X 0.62 LG | |
| 28 | 470-002 | | SCREW, CAP HD, HEX SOC, NO. 2-56 X 0.25 LG | |
| 29 | 470-021 | | SCREW, CAP HD, HEX SOC, NO. 6-32 X 0.62 LG | |
| 30 | 250-007 | | BUMPER, RUBBER | |
| 31 | 471-072 | | SCREW, PAN HD, XREC, NO. 6-32 X 0.62 LG | |
| 32 | 471-356 | | SCREW, FLAT HD, XREC, NO. 10-32 X 0.50 LG | |
| 38 | 492-015 | | NUT, PLAIN, NO. 6-32 | |
| 39 | 493-168 | | NUT, SELF LOCKING, NO. 2-56 | |
| 40 | 496-006 | | NUT, KEP, NO. 8-32 | |
| 42 | 501-009 | | WASHER, PLAIN, NO. 6 | |
| 43 | 501-184 | | WASHER, PLAIN, NO. 2 | |
| 44 | 501-004 | | WASHER, PLAIN, NO. 8 | |
| 45 | 502-002 | | WASHER, LOCK, SPRING, NO. 4 | |
| 46 | 502-003 | | WASHER, LOCK, SPRING, NO. 6 | |
| 50 | 4030386-02 | | HEAD GATE ASSEMBLY, 2-INCH | |
| 51 | 4120026-01 | | CLIP, HEAD ASSY | |
| 52 | 4350208-02 | | COVER, HEAD ASSY | |

N

SHEET 1 OF 1

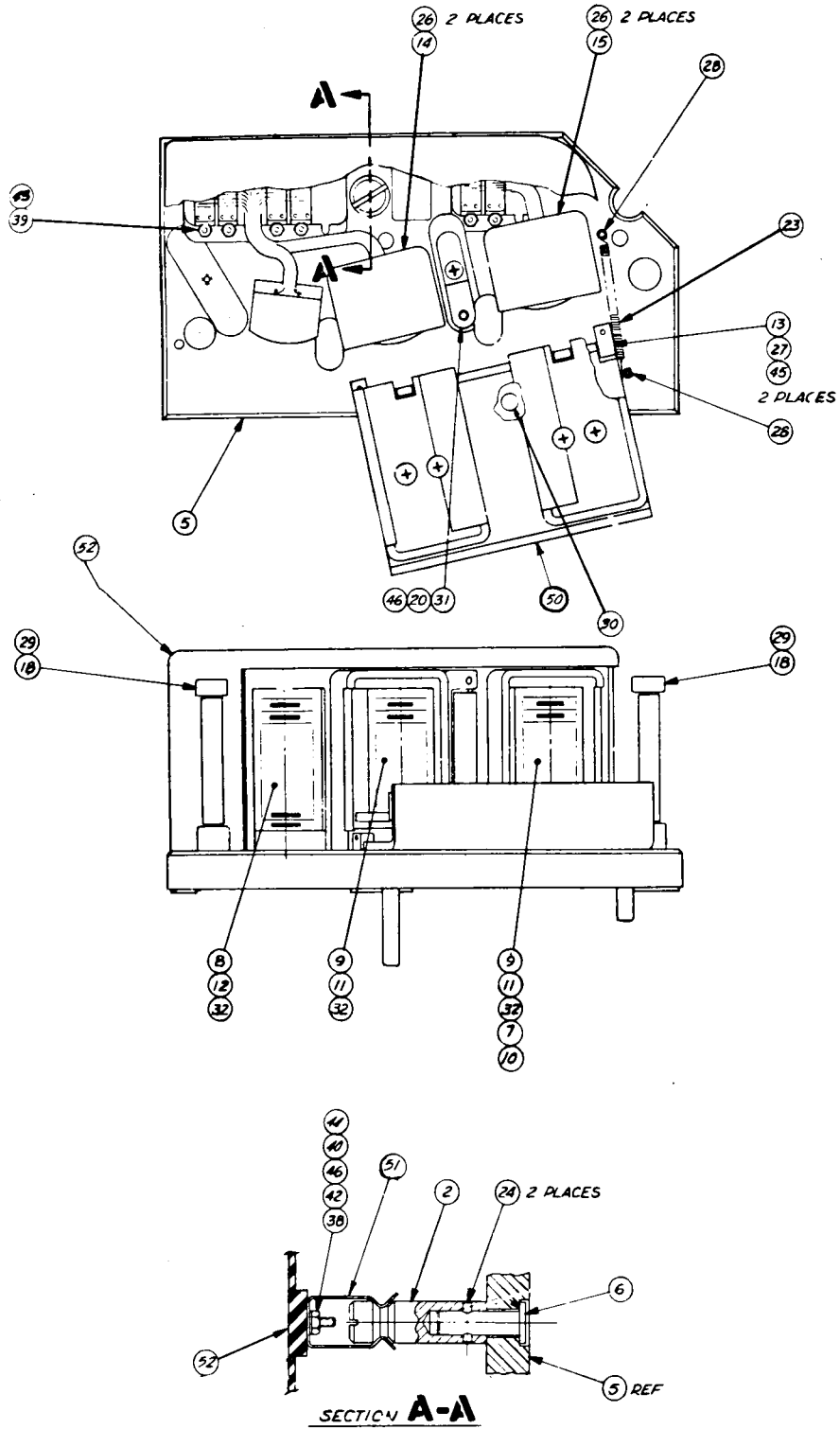

Assembly No. 4020372. Two-Inch Head Assembly, 16- and 24-Channel

| ITEM NO. | AMPEX PART NO. | REFERENCE NUMBER | DESCRIPTION | JEDEC NO. OR MFR. PART NO. |
|----------|----------------|------------------|-------------------------------------------------------|----------------------------|
| | 4952442-02 | | SCRAPE FLUTTER IDLER ASSEMBLY, TWO-INCH (NHA 4020372) | |
| 1 | 4040953-01 | | HOLDER ASSY | |
| 3 | 4952444-01 | | IDLER, SCRAPER FLUTTER | |
| 5 | 477-215 | | SCREW, SET, CUP POINT, NO. 2-56 X 1/8 | |
| 6 | 4952443-02 | | YOKE, SCRAPE FLUTTER | C |

SHEET 1 OF 1

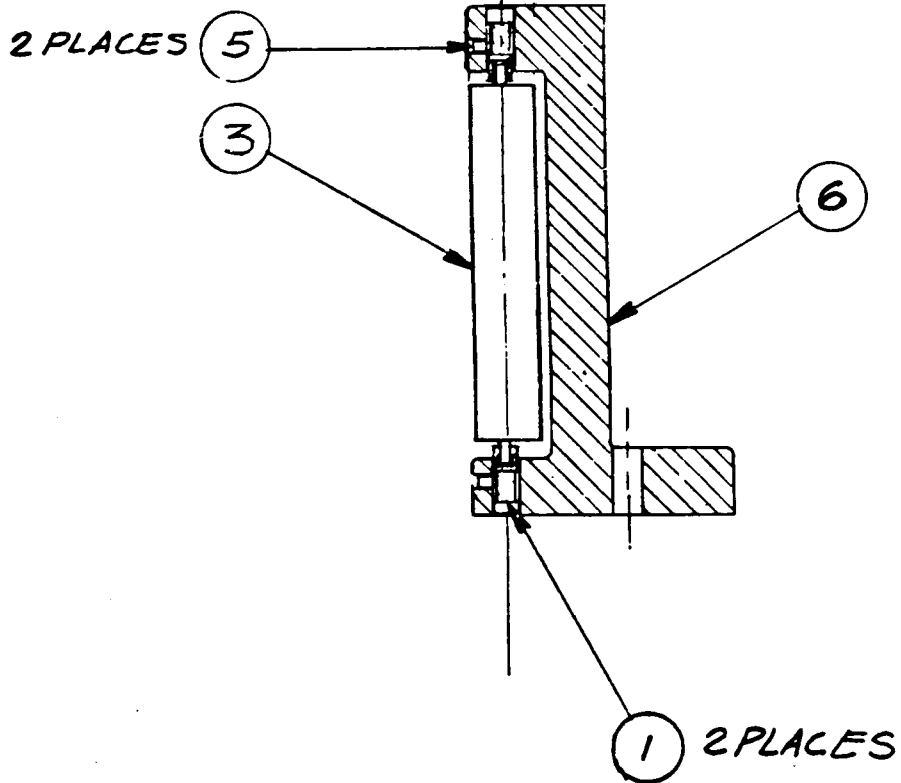

| ITEM NO. | AMPEX PART NO. | REFERENCE NUMBER | DESCRIPTION | JEDEC NO. OR MFR. PART NO. |
|----------|----------------|------------------|-----------------------------------------------|----------------------------|
| | 4020392-02 | | MOTOR DRIVE AMPLIFIER ASSEMBLY (NHA 4010240) | |
| 1 | 4030354-01 | | MOTOR DRIVE AMPLIFIER FAN ASSEMBLY | |
| 3 | 4050768-01 | | MOTOR DRIVE AMPLIFIER HARNESS ASSEMBLY | |
| 4 | 4050771-03 | | MOTOR DRIVE AMPLIFIER PWA | |
| 6 | 4260457-02 | | SUPPORT, CHASSIS | |
| 9 | 4260459-02 | | BRACKET, CONNECTOR | |
| 10 | 4290728-02 | | CHASSIS | |
| 12 | 4290796-01 | | HEATSINK | |
| 14 | 4290831-02 | | COVER, MDA ASSEMBLY | |
| 16 | 4330334-01 | | PLATE, INTERCONNECT | |
| 19 | 1374158-01 | | FILTER | |
| 22 | 014-614 | Q103,104 | TRANSISTOR | 2N3715 |
| 23 | 030-300 | C101,103 | CAPACITOR, CER, 0.1 UF, 500V | |
| 24 | 064-418 | C102 | CAPACITOR, CER, 0.1 UF, 100V | |
| 25 | 043-556 | R101,102,105,106 | RESISTOR, WW, POWER, 1 OHM, 5W, 3% | |
| 26 | 043-806 | R103,104 | RESISTOR, WW, POWER, 0.5 OHM, 5W, 5% | |
| 27 | 043-968 | R107 | RESISTOR, WW, POWER, 0.25 OHM, 5W, 3% | |
| 28 | 147-007 | J101 | CONNECTOR, MALE, CHASSIS MTG, 15 PIN | |
| 29 | 139-413 | J102 | CONNECTOR, 22 PIN | |
| 30 | 180-067 | TB1 | TERMINAL STRIP, 4 LUG | |
| 31 | 173-701 | E1-6 | TERMINAL, FEED THRU | |
| 32 | 580-510 | | SOCKET, TRANSISTOR, T0-3 | |
| 33 | 580-729 | Q101,102,105,106 | TRANSISTOR | 2N5239 |
| 34 | 581-547 | CR101,102 | DIODE | SDA103-3 |
| 35 | 530-343 | | GUIDE, CARD | |
| 37 | 169-818 | | KEY, POLARIZING, REF: J102 | |
| 38 | 471-065 | | SCREW, PAN HD, XREC, NO. 4-40 X 0.62 LG | |
| 39 | 471-069 | | SCREW, PAN HD, XREC, NO. 6-32 X 0.38 LG | |
| 40 | 471-060 | | SCREW, PAN HD, XREC, NO. 4-40 X 0.25 LG | |
| 41 | 471-070 | | SCREW, PAN HD, XREC, NO. 6-32 X 0.44 LG | |
| 42 | 471-072 | | SCREW, PAN HD, XREC, NO. 6-32 X 0.62 LG | |
| 43 | 471-120 | | SCREW, PAN HD, XREC, CRES, NO. 6-32 X 0.44 LG | |
| 48 | 302-525 | | STRAP, CABLE | |
| 52 | 496-005 | | NUT, KEP, NO. 6-32 | |
| 53 | 492-008 | | NUT, PLAIN, HEX, NO. 4 | |
| 54 | 492-009 | | NUT, PLAIN, HEX, NO. 6 | |
| 56 | 501-169 | | WASHER, PLAIN, SM PATTERN, NO. 4 | |
| 57 | 501-008 | | WASHER, PLAIN, NO. 4 | |
| 58 | 501-009 | | WASHER, PLAIN, NO. 6 | |
| 59 | 501-015 | | WASHER, PLAIN, CRES, NO. 6 | |
| 60 | 502-002 | | WASHER, LOCK, SPRING, NO. 4 | |
| 61 | 502-003 | | WASHER, LOCK, SPRING, NO. 6 | |
| 62 | 502-031 | | WASHER, LOCK, INT, CRES, NO. 6 | |
| 65 | 580-445 | | INSULATOR, MICA | |
| 81 | 4840393 | | SCHEMATIC | |

J

4840393

DISTR CODE: S

1

NOTES: UNLESS OTHERWISE SPECIFIED
 1. CAPACITANCE VALUES ARE IN MICROFARADS
 2. RESISTANCE VALUES ARE IN OHMS, 1/4 W, 5%
 3. HEATSINK REQUIRED.
 4. PWA NO. IS 4050771-03, ARTWORK ISSUE LETTER IS 'J'.

| FIELD SERVICE SUBSTITUTION | | REFERENCE DESIGNATION | |
|----------------------------|-----------------------------|-----------------------|---------------------------|
| AMPEX P/N | NEAREST COMM. C. EQUIVALENT | LAST USED | NOT USED |
| 014-383 | 2N2484 | R37 | R5,11,12,17,18,21-23, R26 |
| 014-882 | MPS 3638A | C9 | Q2,4,5 |
| 580-729 | 2N5239 | Q7 | |
| 580-268 | UA741(U9A7741393) | E1 | |
| | | VR2 | |
| | | A2 | |

Schematic No. 4840393F.
 Motor Drive Amplifier Assembly

6-93/94

AMPEX 4890400-02

A FREE download from the Archives at AnalogRules.com

| ITEM NO. | AMPEX PART NO. | REFERENCE NUMBER | DESCRIPTION | JEDEC NO. OR MFR. PART NO. |
|----------|----------------|------------------|--------------------------------------------------|----------------------------|
| | 4030354-01 | | MOTOR DRIVE AMPLIFIER FAN ASSEMBLY (NHA 4020392) | |
| 1 | 4290723-01 | | PANEL, COVER | ROTRON MARK 5- WR2A1 |
| 3 | 591-053 | | FAN | |
| 4 | 471-340 | | SCREW, FLAT HD, 6-32 X 0.75 LG | |
| 5 | 492-034 | | NUT, PLAIN, HEX, NO. 6 | |
| 6 | 501-009 | | WASHER, PLAIN, NO. 6 | |
| 7 | 502-003 | | WASHER, LOCK, HELICAL SPRING, NO. 6 | |
| | | | | |

SHEET 1 OF 1

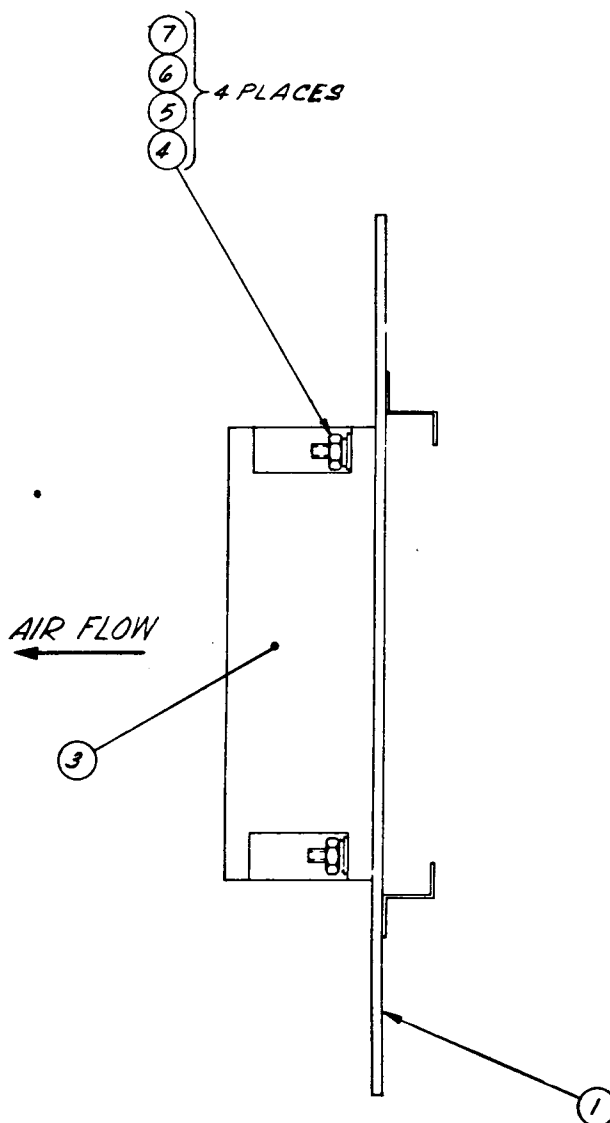

| ITEM NO. | AMPEX PART NO. | REFERENCE NUMBER | DESCRIPTION | JEDEC NO. OR MFR. PART NO. |
|----------|--------------------------------------|------------------|------------------------------------------------------------------------------------------------------------|----------------------------|
| 1 3 | 4050768-01 171-238 591-140 | | MOTOR DRIVE AMPLIFIER HARNESS ASSEMBLY (NHA 4020392) TERMINAL, QUICK DISCONNECT, FEMALE CORD, POWER | |

B

| ITEM NO. | AMPEX PART NO. | REFERENCE NUMBER | DESCRIPTION | JEDEC NO. OR MFR. PART NO. |
|----------|----------------|------------------|----------------------------------------------------|----------------------------|
| | 4050771-03 | | MOTOR DRIVE AMPLIFIER PWA (NHA 4020392) | |
| 4 | 4120025-01 | | HANDLE, PWB | |
| 5 | 103307-01 | | STANDOFF, REF: R7,32 | |
| 8 | 013-828 | VR1,2 | DIODE | 1N3015B |
| 9 | 014-383 | Q3,6 | TRANSISTOR | 2N2484 |
| 11 | 580-742 | | HEATSINK, REF: Q1,7 | |
| 12 | 037-895 | C6 | CAPACITOR, TANT, 3.3 UF, 35V, 20% | |
| 13 | 064-434 | C2,3,9 | CAPACITOR, FIXED, CER, 5000 PF, 1KV | |
| 14 | 069-048 | C4,5 | CAPACITOR, POLYFOIL, 1.0 UF, 400V, 10% | |
| 16 | 064-116 | C7 | CAPACITOR, CER, DISC, 0.01 UF, 50V, +80% -20% | |
| 18 | 041-336 | R10,33 | RESISTOR, COMP, 470 OHM, 1/2W, 5% | |
| 19 | 041-393 | R4,30 | RESISTOR, COMP, 1M, 1/4W, 5% | |
| 20 | 041-394 | R13,31 | RESISTOR, COMP, 100K, 1/4W, 5% | |
| 21 | 041-406 | R6,27 | RESISTOR, COMP, 22K, 1/4W, 5% | |
| 22 | 058-202 | R15,16 | RESISTOR, VAR, CAR, 50K, 1/4W, 30% | |
| 27 | 041-549 | R3,29 | RESISTOR, COMP, 13K, 1/4W, 5% | |
| 28 | 041-612 | R8,9,14,28,34,35 | RESISTOR, COMP, 30K, 1/4W, 5% | |
| 29 | 041-984 | R7,32 | RESISTOR, COMP, 15K, 2W, 5% | |
| 30 | 062-997 | R1,25 | RESISTOR, MF, 18.2K, 1/8W, 1% | |
| 33 | 280-921 | | SPACER, UNTHREADED, 0.375 OD X 0.194 ID X 0.250 LG | |
| 34 | 580-219 | Q1,7 | TRANSISTOR | 2N4240 |
| 35 | 586-268 | A1,2 | INTEGRATED CIRCUIT | UA741 |
| 36 | 041-465 | R19,20 | RESISTOR, COMP, 680 OHM, 1W, 5% | |
| 37 | 076-065 | R2,24 | RESISTOR, MF, 22.1K, 1/8W, 1% | |
| 38 | 302-388 | | STRAP, CABLE | |
| 41 | 471-069 | | SCREW, PAN HD, XREC, NO. 6-32 X 3/8 LG | |
| 42 | 496-005 | | NUT, KEP, NO. 6-32 | |
| 46 | 473-324 | | SCREW, PAN HD, SEM, NO. 4-40 X 1/4 | |
| 47 | 501-008 | | WASHER, FLAT, NO. 4 | |
| 51 | 492-463 | | NUT, HEX, SMALL PAT, NO. 10-32 | |
| 58 | 035-853 | C1,8 | CAPACITOR, MYLAR, 0.056 UF, 50V, 5% | |
| 59 | 041-415 | R36,37 | RESISTOR, COMP, 68K, 1/4W, 5% | |
| 80 | 4840393 | | SCHEMATIC | |

J

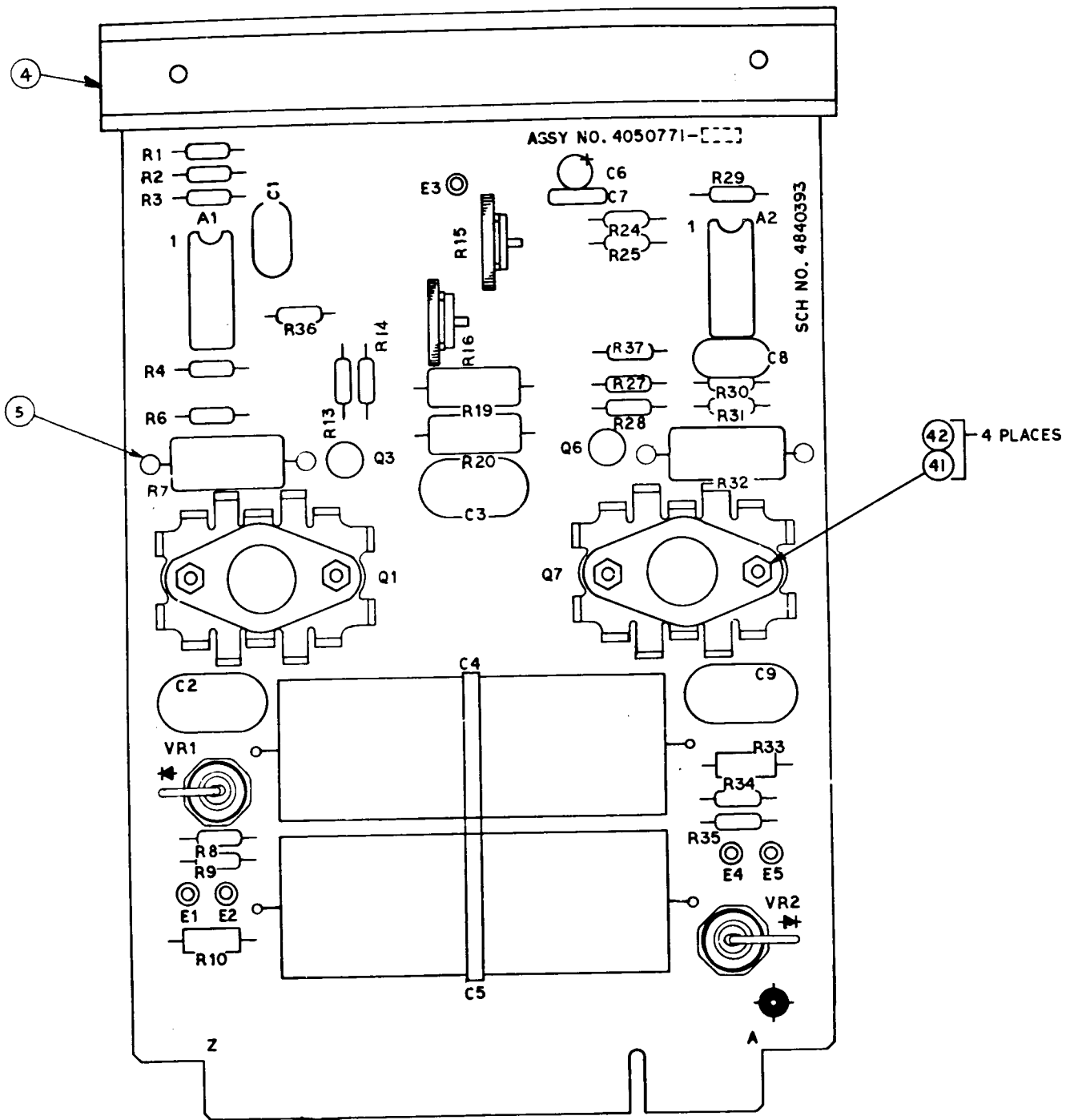

Assembly No. 4050771. Motor Drive Amplifier PWA

| ITEM NO. | AMPEX PART NO. | REFERENCE NUMBER | DESCRIPTION | JEDEC NO. OR MFR. PART NO. |
|----------|----------------|------------------|-----------------------------------------------|----------------------------|
| | 4020393-04 | | POWER SUPPLY ASSEMBLY (NHA 4010240) | |
| 3 | 4030356-03 | | POWER SUPPLY FUSE PANEL ASSEMBLY | |
| 4 | 4041216-01 | | SHIELD ASSY | |
| 5 | 4030355-02 | | POWER SUPPLY HEATSINK ASSEMBLY | |
| 6 | 4050699-09 | PC1 | REGULATOR PWA, 39V | |
| 7 | 4050699-10 | PC2 | REGULATOR PWA, 15/27V | |
| 8 | 4050797-01 | | POWER SUPPLY HARNESS ASSEMBLY | |
| 9 | 4170324-01 | | INSULATOR, TRANSFORMER | |
| 11 | 4230133-02 | | GUIDE, PWB | |
| 14 | 4260478-02 | | BRACKET, MTG, CONNECTOR | |
| 15 | 4290774-01 | | COVER, TOP | |
| 18 | 4050847-01 | | JUMPER, TRANSFORMER, YELLOW | |
| 19 | 4050847-02 | | JUMPER, TRANSFORMER, ORANGE | |
| 20 | 4580062-01 | T1 | TRANSFORMER, POWER | |
| 21 | 4290776-02 | | CHASSIS | |
| 22 | 4290809-02 | | COVER, REAR | |
| 23 | 031-411 | C6 | CAPACITOR, ALUM, 500 UF, 25V, -10+50% | |
| 24 | 037-152 | C3 | CAPACITOR, TANT, 82 UF, 50V, 20% | |
| 26 | 041-305 | R1,2 | RESISTOR, COMP, 5.1K, 1W, 5% | |
| 28 | 030-300 | C8,9 | CAPACITOR, CER, DISC, 0.1 UF, 500V, 20% | |
| 29 | 063-182 | C1,2 | CAPACITOR, ALUM, 10K UF, 75V, -10+75% | |
| 30 | 063-183 | C4,5 | CAPACITOR, ALUM, 1400 UF, 75V, -10+50% | |
| 31 | 171-007 | | LUG, TERMINAL, CRIMP, RING | |
| 32 | 171-178 | | LUG, TERMINAL, CRIMP, SPADE | |
| 33 | 180-032 | | TERMINAL STRIP | |
| 34 | 172-181 | | LUG, SOLDER, TERM, RING, NO. 6 | |
| 36 | 290-108 | | CLAMP, CAPACITOR, 2 INCH DIA | |
| 39 | 301-130 | | CLAMP, CAPACITOR, 1 3/8 INCH DIA | |
| 40 | 302-525 | | STRAP, CABLE, W/MTG PLATE | |
| 41 | 470-016 | | SCREW, HEX SOC HD, NO. 6-32 X 0.250 LG | |
| 42 | 471-065 | | SCREW, PAN HD, XREC, NO. 4-40 X 0.625 LG | |
| 43 | 471-069 | | SCREW, PAN HD, XREC, NO. 6-32 X 0.375 LG | |
| 44 | 471-071 | | SCREW, PAN HD, XREC, NO. 6-32 X 0.50 LG | |
| 45 | 471-072 | | SCREW, PAN HD, XREC, NO. 6-32 X 0.62 LG | |
| 46 | 471-073 | | SCREW, PAN HD, XREC, NO. 6-32 X 0.750 LG | |
| 47 | 475-044 | | SCREW, PAN HD, KEP, XREC, NO. 8-32 X 0.375 LG | |
| 48 | 492-008 | | NUT, PLAIN, NO. 4-40 | |
| 49 | 492-009 | | NUT, PLAIN, HEX, NO. 6-32 | |
| 50 | 492-467 | | NUT, PLAIN, HEX, NO. 1/4-20 | |
| 51 | 470-021 | | SCREW, HEX, SOC HD, NO. 6-32 X 0.625 LG | |
| 52 | 496-005 | | NUT, KEP, NO. 6-32 | |
| 53 | 501-008 | | WASHER, PLAIN, NO. 4 | |
| 54 | 501-009 | | WASHER, PLAIN, NO. 6 | |
| 55 | 501-067 | | WASHER, PLAIN, NO. 1/4 | |
| 56 | 502-002 | | WASHER, LOCK, NO. 4 | |
| 57 | 502-003 | | WASHER, LOCK, SPRING, NO. 6 | |
| 58 | 502-006 | | WASHER, LOCK, NO. 1/4 | |
| 59 | 501-169 | | WASHER, PLAIN, SMALL PAT, NO. 4 | |
| 60 | 471-471 | | SCREW, PAN HD, NO. 4-40 X 0.75 LG | |
| 61 | 581-251 | | DIODE ASSEMBLY | |
| 65 | 591-053 | B1 | FAN | INTL RECT 400 JB4L |
| 80 | 4840404 | | SCHEMATIC, POWER SUPPLY | |
| 81 | 4840337 | | SCHEMATIC, 39V REGULATOR | |
| 82 | 4840339 | | SCHEMATIC, 15V/27V REGULATOR | |

K

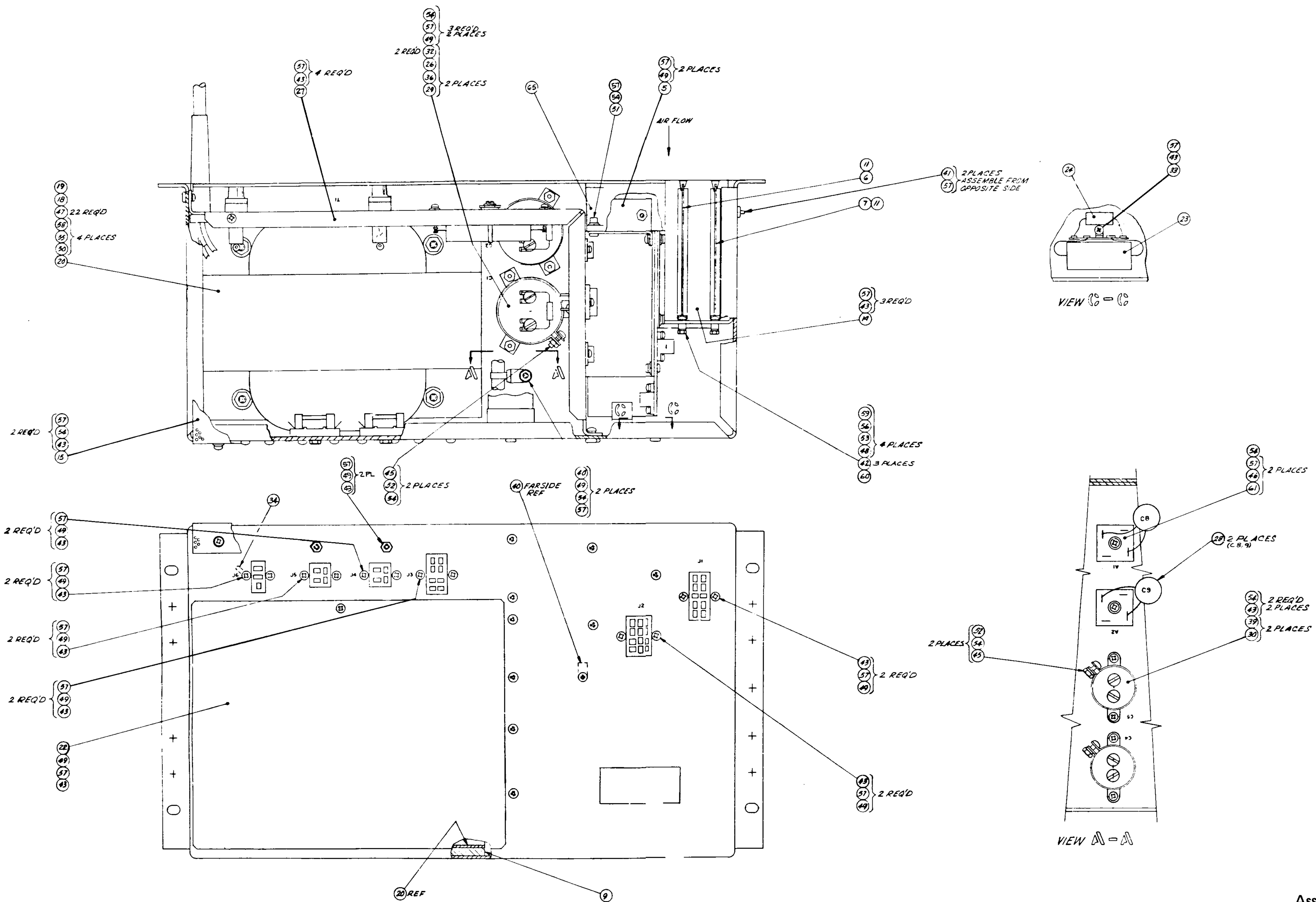

Assembly No. 4020393.
 Power Supply Assembly

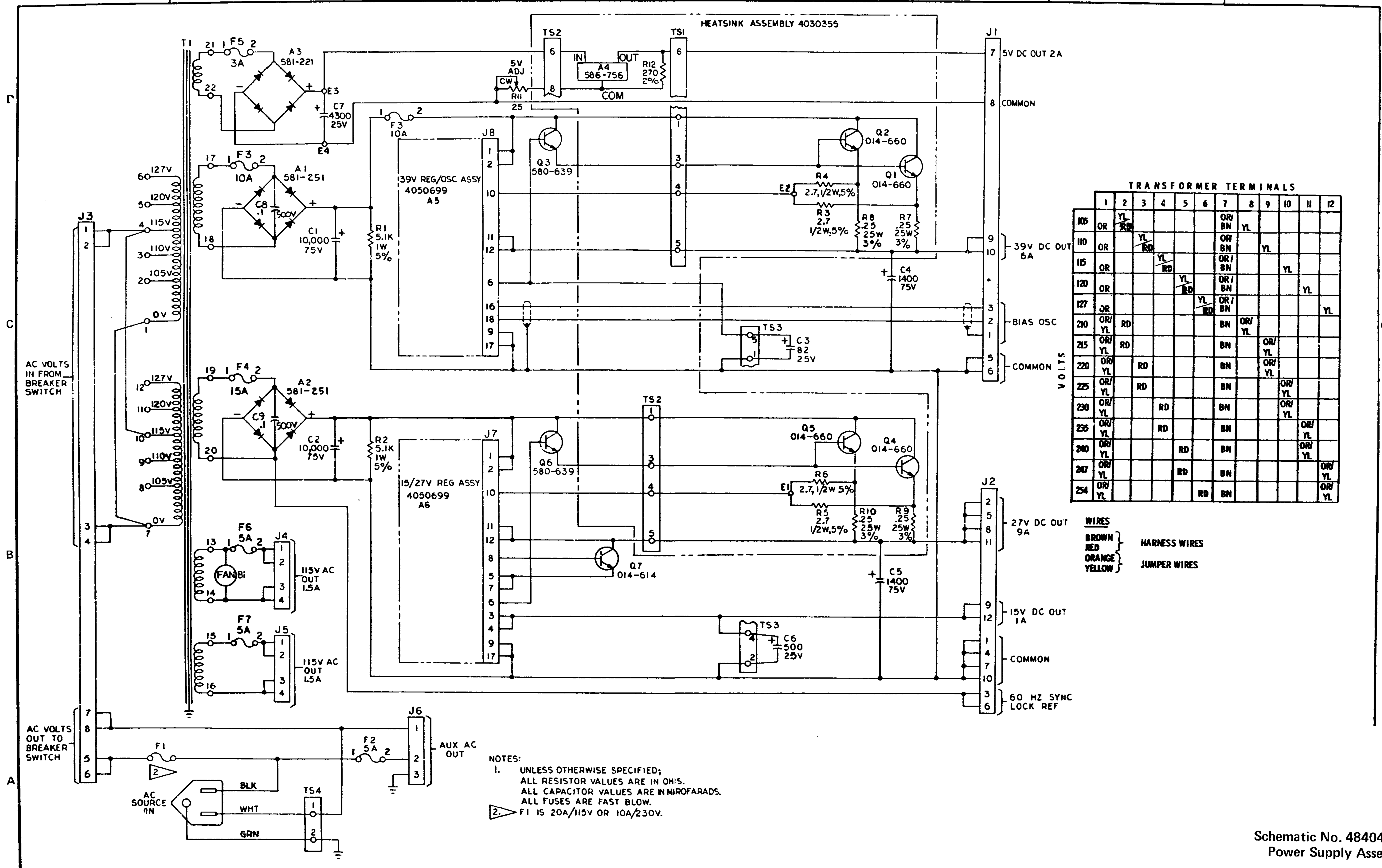

TRANSFORMER TERMINALS

| | 1 | 2 | 3 | 4 | 5 | 6 | 7 | 8 | 9 | 10 | 11 | 12 |
|-----|-------|----|----|----|----|----|-------|-------|-------|-------|-------|-------|
| 105 | OR | YL | | | | | OR/BN | YL | | | | |
| 110 | OR | | YL | | | | OR/BN | | YL | | | |
| 115 | OR | | | YL | | | OR/BN | | | YL | | |
| 120 | OR | | | | YL | | OR/BN | | | | YL | |
| 127 | JR | | | | | YL | OR/BN | | | | | YL |
| 210 | OR/YL | RD | | | | | BN | OR/YL | | | | |
| 215 | OR/YL | RD | | | | | BN | | OR/YL | | | |
| 220 | OR/YL | | RD | | | | BN | | OR/YL | | | |
| 225 | OR/YL | | RD | | | | BN | | | OR/YL | | |
| 230 | OR/YL | | | RD | | | BN | | | OR/YL | | |
| 235 | OR/YL | | | RD | | | BN | | | | OR/YL | |
| 240 | OR/YL | | | | RD | | BN | | | | OR/YL | |
| 247 | OR/YL | | | | RD | | BN | | | | | OR/YL |
| 254 | OR/YL | | | | | RD | BN | | | | | OR/YL |

WIRES
 BROWN } HARNESS WIRES
 RED }
 ORANGE } JUMPER WIRES
 YELLOW }

NOTES:
 1. UNLESS OTHERWISE SPECIFIED;
 ALL RESISTOR VALUES ARE IN OHMS.
 ALL CAPACITOR VALUES ARE IN MICROFARADS.
 ALL FUSES ARE FAST BLOW.
 2. F1 IS 20A/115V OR 10A/230V.

Schematic No. 4840404G.
 Power Supply Assembly

| ITEM NO. | AMPEX PART NO. | REFERENCE NUMBER | DESCRIPTION | JEDEC NO. OR MFR. PART NO. |
|----------|----------------|------------------|---------------------------------------------------|----------------------------|
| | 4030355-02 | | POWER SUPPLY HEATSINK ASSEMBLY (NHA 4020393) | |
| 2 | 4290720-01 | | HEATSINK | |
| 5 | 014-660 | Q1,2,4,5 | TRANSISTOR | 2N3773 |
| 6 | 041-657 | R3-6 | RESISTOR, COMP, 2.7 OHM, 1/2W, 5% | |
| 7 | 047-748 | R7-10 | RESISTOR, WW, 0.25 OHM, 25W, 3% | |
| 12 | 475-062 | | SCREW, PAN HD, SEM, NO. 6-32 X 0.625 LG | |
| 13 | 471-071 | | SCREW, PAN HD, XREC, NO. 6-32 X 0.500 LG | |
| 14 | 302-525 | | STRAP, CABLE | |
| 15 | 476-505 | | SCREW, TAP, PAN HD, TRI LOBE, NO. 4-40 X 0.250 LG | |
| 18 | 492-009 | | NUT, PLAIN, HEX, NO. 6 | |
| 19 | 4290796-01 | | HEATSINK | |
| 20 | 180-039 | TS1,2 | TERMINAL STRIP, 8 TERM | |
| 22 | 501-009 | | WASHER, PLAIN, NO. 6 | |
| 23 | 477-497 | | SCREW, SET, NO. 6-32 X 0.250 LG | |
| 24 | 502-002 | | WASHER, LOCK, SPRING, NO. 4 | |
| 25 | 502-003 | | WASHER, LOCK, SPRING, NO. 6 | |
| 26 | 586-756 | A4 | INTEGRATED CIRCUIT | LM3091C |
| 27 | 580-445 | | INSULATOR, MICA, T0-3 | |
| 28 | 580-510 | | SOCKET, TRANSISTOR, T03 | |
| 29 | 471-062 | | SCREW, PAN HD, XREC, NO. 4-40 X 0.375 LG | |
| 30 | 173-702 | E1,2 | TERMINAL, STANDOFF, TURRET | |
| 32 | 471-069 | | SCREW, PAN HD, XREC, NO. 6-32 X 0.375 LG | |
| 34 | 057-082 | R12 | RESISTOR, METAL FILM, 270 OHM, 1/4W, 2% | |
| 35 | 4260479-03 | | SUPPORT, HEATSINK | |
| 36 | 4260528-02 | | BRACKET, FAN | |
| 37 | 471-070 | | SCREW, PAN HD, XREC, NO. 6-32 X 0.44 LG | |
| 38 | 302-335 | | STRAP, CABLE | |

E

SHEET 1 OF 1

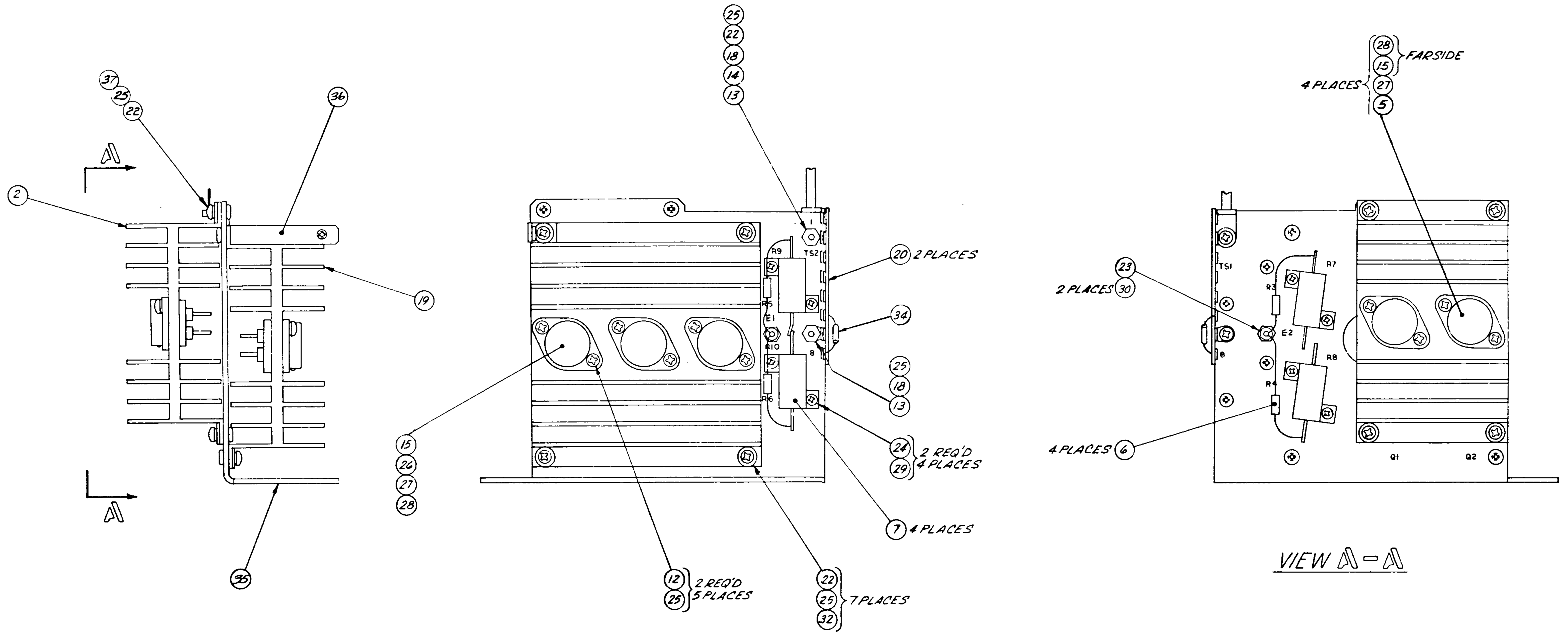

Assembly No. 4030355.
Power Supply Heatsink Assembly

| ITEM NO. | AMPEX PART NO. | REFERENCE NUMBER | DESCRIPTION | JEDEC NO. OR MFR. PART NO. |
|----------|----------------|------------------|------------------------------------------------|----------------------------|
| | 4030356-03 | | POWER SUPPLY FUSE PANEL ASSEMBLY (NHA 4020393) | |
| 1 | 4260477-03 | | BRACKET, MTG, FUSE | |
| 4 | 070-001 | F5 | FUSE, FAST BLO, 3A | |
| 5 | 070-054 | F3,4 | FUSE, FAST BLO, 10A | |
| 6 | 085-001 | | FUSEHOLDER | |
| 7 | 476-424 | | SCREW, SHEET METAL, NO. 6-20 X 0.50 LG | |
| 9 | 471-328 | | SCREW, FLAT HD, NO. 4-40 X 0.375 LG | |
| 10 | 471-071 | | SCREW, PAN HD, XREC, NO. 6-32 X 0.50 LG | |
| 12 | 492-032 | | NUT, PLAIN, HEX, SMALL PATTERN, NO. 4 | |
| 13 | 580-510 | | SOCKET, MTG, TRANS, T0-3, REF: Q7 | |
| 14 | 580-474 | | SOCKET, MTG, TRANS, T0-66, REF: Q3,6 | |
| 15 | 084-061 | | CORD, POWER | |
| 16 | 580-445 | | INSULATOR, MICA, T0-3, REF: Q7 | |
| 17 | 014-802 | | INSULATOR, MICA, T0-66, REF: Q3,6 | |
| 18 | 014-614 | Q7 | TRANSISTOR | 2N3715 |
| 19 | 580-639 | Q3,6 | TRANSISTOR | 2N6295 |
| 20 | 070-303 | F1 | FUSE, FAST BLO, 20A | |
| 21 | 070-007 | F2 | FUSE, FAST BLO, 5A | |
| 22 | 063-296 | C7 | CAPACITOR, AL, ELECT, 4300 UF, 25V, -10% + 75% | |
| 23 | 581-221 | A3 | DIODE | SJA J6 |
| 26 | 471-067 | | SCREW, PAN HD, NO. 6-32 X 0.250 LG | |
| 27 | 173-702 | | TERMINAL, STANDOFF | |
| 28 | 302-525 | | STRAP, CABLE | |
| 29 | 501-009 | | WASHER, PLAIN, NO. 6 | |
| 30 | 471-327 | | SCREW, FLAT HD, NO. 4-40 X 0.312 LG | |
| 31 | 496-004 | | NUT, KEP, NO. 4 | |
| 32 | 180-025 | TS4 | TERMINAL STRIP | |
| 33 | 502-025 | | WASHER, SPRING, NO. 6 | |
| 34 | 471-068 | | SCREW, PAN HD, XREC, NO. 6-32 X 0.312 | |
| 35 | 4520149-10 | R11 | RESISTOR, VAR, 25 OHM, MOD | |
| 36 | 502-083 | | WASHER, LOCK, INTERNAL TOOTH, 3/8 | |
| 37 | 492-457 | | NUT, HEX, NO. 3/8-32 | G |

SHEET 1 OF 1

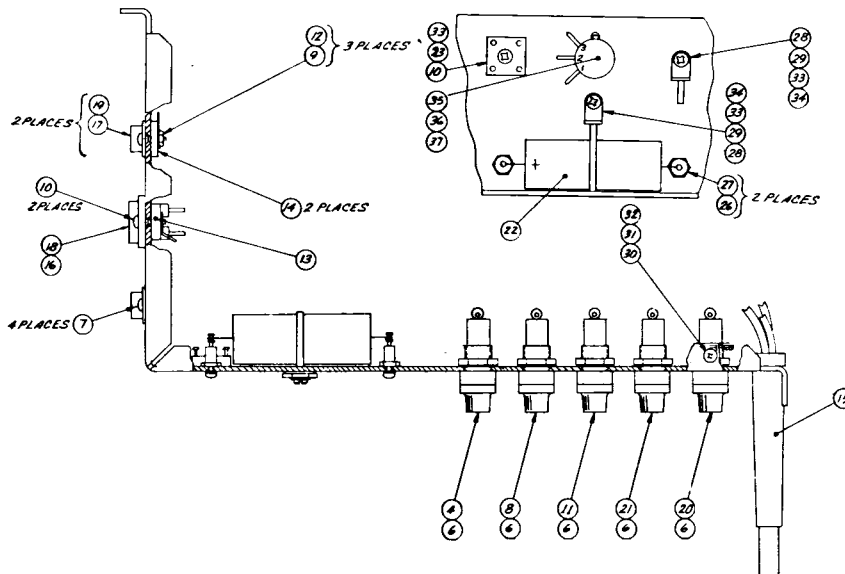

| ITEM NO. | AMPEX PART NO. | REFERENCE NUMBER | DESCRIPTION | JEDEC NO. OR MFR. PART NO. |
|----------|--------------------------|------------------|-------------------------------------------------------------------------|----------------------------|
| | 4050699-09 4050699-10 | | REGULATOR PWA, 39V (NHA 4020393) REGULATOR PWA, 15/27V (NHA 4020393) | |
| 4 | 4840337 | | SCHEMATIC, 39V | |
| 5 | 4840339 | | SCHEMATIC, 15/27V | |
| 7 | 52528-01 | | HANDLE, SNAP ON | |
| 10 | 013-599 | CR3,4 | DIODE | 1N914 |
| 11 | 013-678 | CR1 | DIODE (39V PWA) | 1N4005 |
| 12 | 013-678 | CR1,2 | DIODE (15/27V PWA) | 1N4005 |
| 13 | 013-747 | VR6 | DIODE (39V PWA) | 2E213.0D5 |
| 14 | 581-296 | VR2 | DIODE (39V PWA) | 1N4755A |
| 15 | 013-911 | VR2 | DIODE (15/27V PWA) | 1N4752 |
| 16 | 013-370 | VR4 | DIODE (15/27V PWA) | 1N4736 |
| 17 | 581-197 | VR1 | DIODE | 1N4738 |
| 18 | 581-202 | VR3 | DIODE | 1N4739 |
| 19 | 581-203 | VR5 | DIODE (15/27V PWA) | 1N4745 |
| 20 | 580-616 | Q8,9 | TRANSISTOR | 2N4036 |
| 22 | 014-247 | Q1 | TRANSISTOR (15/27V PWA) | 2N2219 |
| 23 | 014-555 | | HEATSINK, TRANSISTOR, T0-5, REF: Q2,4 | |
| 24 | 014-590 | Q4 | TRANSISTOR (39V PWA) | 2N3053 |
| 25 | 014-590 | Q2,4 | TRANSISTOR (15/27V PWA) | 2N3053 |
| 26 | 014-653 | Q6,7 | TRANSISTOR (39V PWA) | 2N3904 |
| 27 | 014-070 | | HEATSINK, TRANSISTOR, T0-5, REF: Q8,9 | |
| 29 | 014-931 | Q3 | THYRISTOR | C106B2-GE |
| 30 | 030-057 | C2 | CAPACITOR, CER, 0.01 UF, 50V, 20% (39V PWA) | |
| 31 | 030-057 | C2,3 | CAPACITOR, CER, 0.01 UF, 50V, 20% (15/27V PWA) | |
| 32 | 055-491 | C8 | CAPACITOR, CER, 0.1 UF, 50V, 10% (39V PWA) | |
| 33 | 580-564 | Q5 | THYRISTOR | 2N4442 |
| 34 | 034-507 | C5,6 | CAPACITOR, MICA, 5600 PF, 300V, 5% (39V PWA) | |
| 35 | 034-958 | C7 | CAPACITOR, MICA, 2200 PF, 500V, 5% (39V PWA) | |
| 37 | 037-363 | C1 | CAPACITOR, TANT, 330 UF, 6V, 10% | |
| 38 | 041-003 | R12 | RESISTOR, COMP, 100 OHM, 1/2W, 5% | |
| 40 | 041-008 | R3,15,16 | RESISTOR, COMP, 1.5K, 1/2W, 5% (15/27V PWA) | |
| 41 | 041-010 | R7,11 | RESISTOR, COMP, 2K, 1/2W, 5% | |
| 42 | 041-016 | R21,22 | RESISTOR, COMP, 22K, 1/2W, 5% (39V PWA) | |
| 43 | 041-135 | R14 | RESISTOR, COMP, 39 OHM, 1W, 10% (15/27V PWA) | |
| 44 | 041-147 | R23 | RESISTOR, COMP, 1.2K, 1W, 10% (39V PWA) | |
| 47 | 041-317 | R27 | RESISTOR, COMP, 820 OHM, 1/2W, 5% (39V PWA) | |
| 49 | 041-533 | R19,20 | RESISTOR, COMP, 24 OHM, 1/2W, 5% (39V PWA) | |
| 51 | 041-245 | R5 | RESISTOR, COMP, 1K, 1/2W, 5% | |
| 53 | 047-612 | R8 | RESISTOR, WW, 1 OHM, 10W, 3% | |
| 54 | 041-485 | R4 | RESISTOR, COMP, 16 OHM, 1/2W, 5% | |
| 56 | 056-108 | C4 | CAPACITOR, MICA, 6800 PF, 500V, 5% (39V PWA) | |
| 57 | 041-606 | R13 | RESISTOR, COMP, 220 OHM, 2W, 5% (15/27V PWA) | |
| 58 | 058-569 | R1 | RESISTOR, VAR, CER, 2K, 1W, 10% (39V PWA) | |
| 59 | 058-569 | R1,2 | RESISTOR, VAR, CER, 2K, 1W, 10% (15/27V PWA) | |
| 60 | 047-364 | R17 | RESISTOR, WW, 0.47 OHM, 2W, 5% (15/27V PWA) | |
| 62 | 044-941 | R6 | RESISTOR, VAR, CER, 100 OHM, 1/2W, 20% | |
| 63 | 041-317 | R18,27 | RESISTOR, COMP, 820 OHM, 1/2W, 5% (15/27V PWA) | |
| 64 | 148-057 | TP2 | CONNECTOR, JACK, PC TIP, GRN (15/27V PWA) | |
| 65 | 148-058 | TP1 | CONNECTOR, JACK, PC TIP, RED | |
| 66 | 148-059 | TPG | CONNECTOR, JACK, PC TIP, BLK | |
| 67 | 037-728 | C9,10 | CAPACITOR, TANT, 6.8 UF, 6V, 10% | |
| 68 | 280-998 | | PAD, MTG, TRANSISTOR, T0-5 | |
| 71 | 103307-04 | | STANDOFF, SPACER, 0.38 LF, REF: R8 | |
| 76 | 041-014 | R10 | RESISTOR, COMP, 10K, 1/2W, 5% | |
| 77 | 041-283 | R24 | RESISTOR, COMP, 47 OHM, 1/2W, 5% | |
| 78 | 041-329 | R25 | RESISTOR, COMP, 330 OHM, 1/2W, 5% | |
| 79 | 041-245 | R26 | RESISTOR, COMP, 1K, 1/2W, 5% | K |

-09

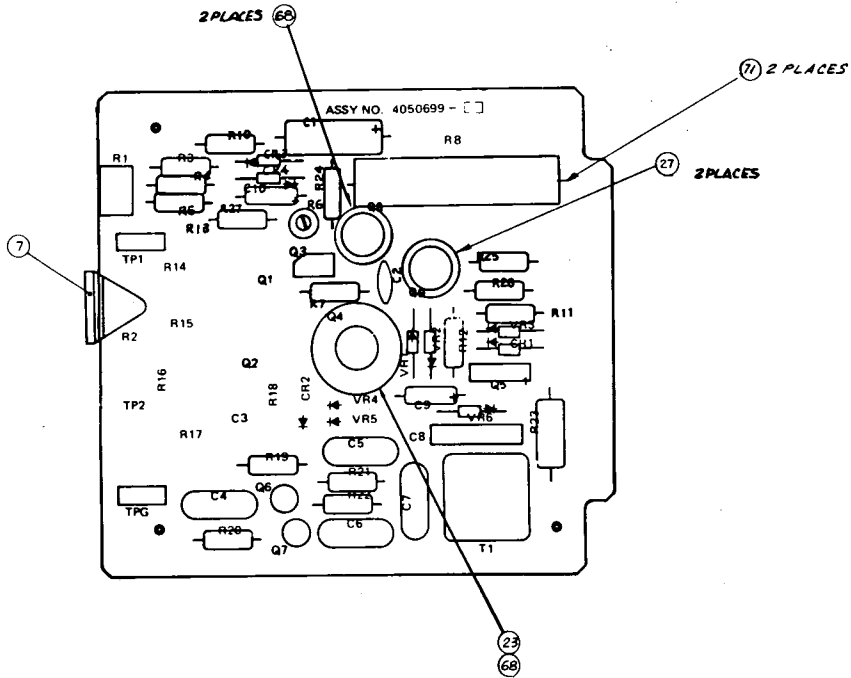

-10

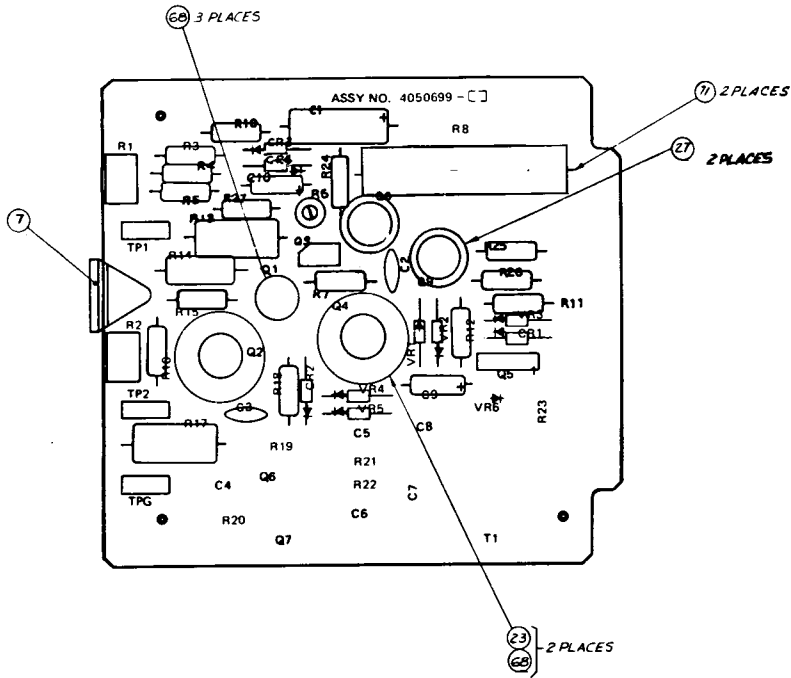

Assembly No. 4050699. Regulator PWA

D
C
B
A

D
C
B
A

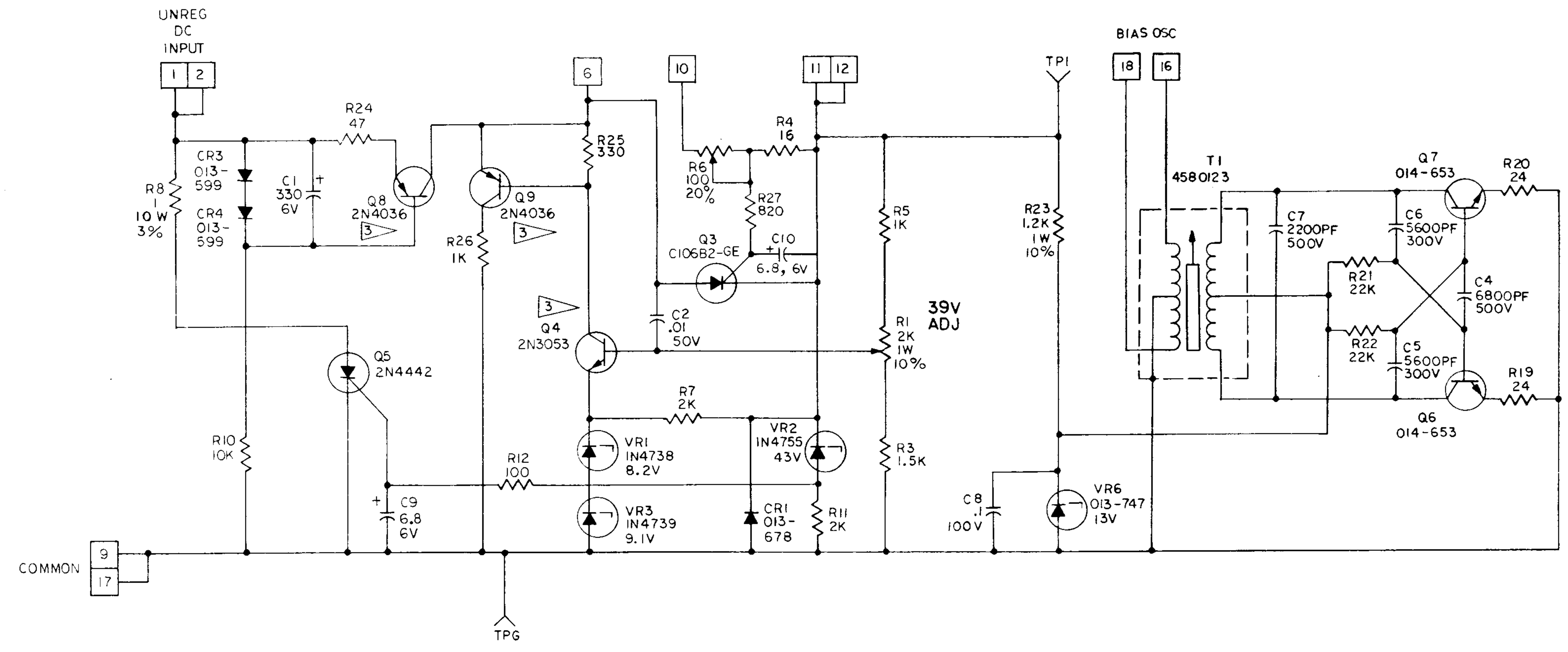

NOTES: UNLESS OTHERWISE SPECIFIED
 1. CAPACITANCE VALUES ARE IN MICROFARADS.
 2. RESISTANCE VALUES ARE IN OHMS, 1/2W, 5%.
 3 THIS TRANSISTOR TO HAVE HEAT SINK.

| REFERENCE DESIGNATIONS | |
|------------------------|--------------|
| LAST USED | NOT USED |
| C10 | C3 |
| CR4 | CR2 |
| Q9 | Q1, 2 |
| R27 | R2, 9, 13-18 |
| VR6 | VR4, 5 |
| TPI TPG | |

| FIELD SERVICE COMPONENT SUBSTITUTION LIST | |
|-------------------------------------------|-------------------------------|
| AMPEX P/N | NEAREST COMMERCIAL EQUIVALENT |
| 014-653 | 2N3904 |

TABLE I

| PWA DASH NUMBER | SCHEMATIC ISSUE |
|-----------------|-----------------|
| 4050699-05 | "B" |
| 4050699-07 | "C" |
| 4050699-09 | "F" |

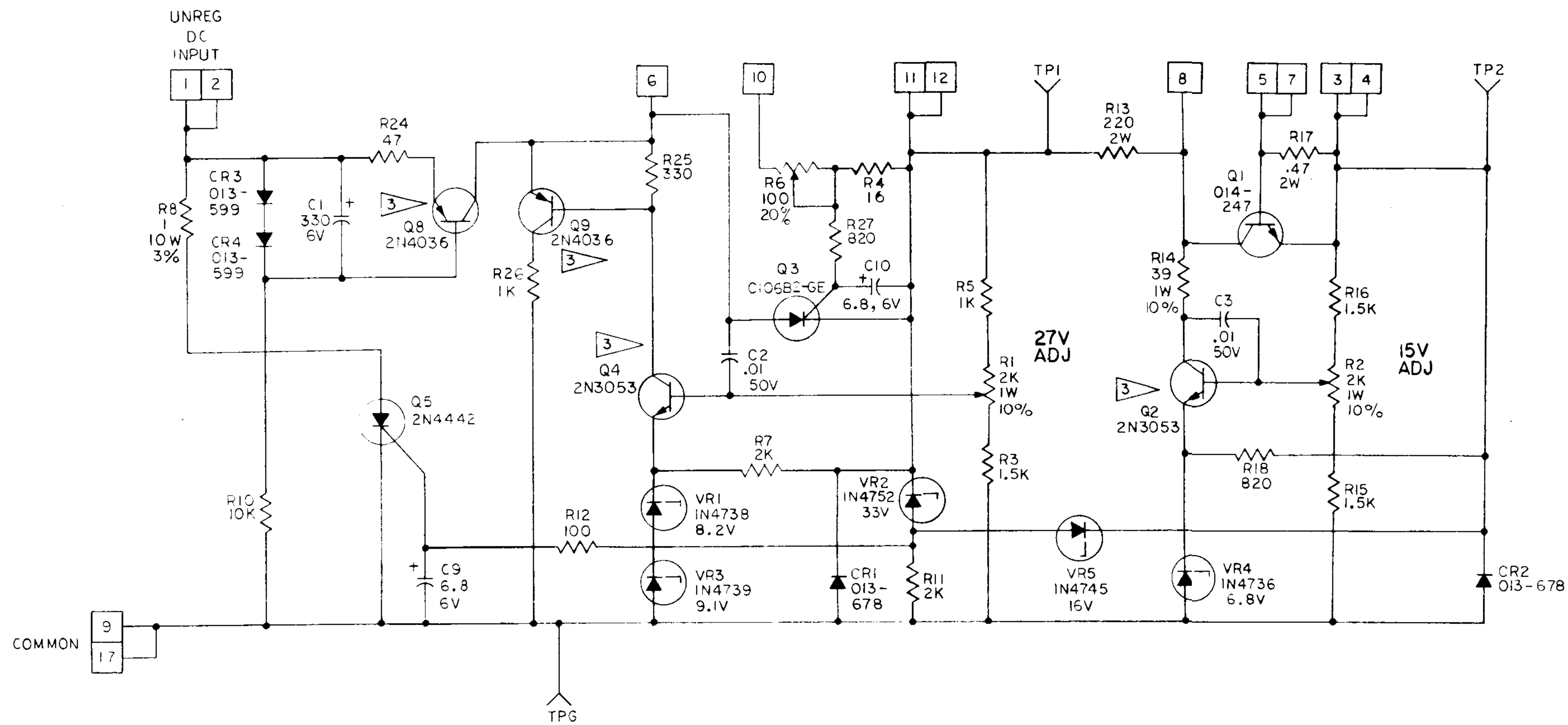

NOTES: UNLESS OTHERWISE SPECIFIED
 1. CAPACITANCE VALUES ARE IN MICROFARADS.
 2. RESISTANCE VALUES ARE IN OHMS, 1/2W, 5%.
 3. THIS TRANSISTOR TO HAVE HEAT SINK.

| REFERENCE DESIGNATIONS | |
|------------------------|------------|
| LAST USED | NOT USED |
| C10 | C4 THRU C8 |
| CR4 | |
| Q9 | Q6,7 |
| R27 | R9,19-23 |
| VR5 | |
| TP2 TPG | |

| FIELD SERVICE COMPONENT SUBSTITUTION LIST | |
|-------------------------------------------|-------------------------------|
| AMPEX P/N | NEAREST COMMERCIAL EQUIVALENT |
| 014-247 | 2N2219 |

TABLE I

| PWA DASH NUMBER | SCHEMATIC ISSUE |
|-----------------|-----------------|
| 4050699-06 | "B" |
| 4050699-08 | "C" |
| 4050699-10 | "E" |

| ITEM NO. | AMPEX PART NO. | REFERENCE NUMBER | DESCRIPTION | JEDEC NO. OR MFR. PART NO. |
|----------|----------------|------------------|---------------------------------------------|----------------------------|
| | 4050797-01 | | POWER SUPPLY HARNESS ASSEMBLY (NHA 4020393) | |
| 1 | 143-307 | J7,8 | CONNECTOR, PC RECP, 18 CONTACTS | |
| 2 | 146-003 | J3 | CONNECTOR, RECT RECP, 8 SOC | |
| 3 | 146-005 | J4,5 | CONNECTOR, RECT RECP, 4 SOC | |
| 4 | 146-009 | J2 | CONNECTOR, RECT RECP, 12 SOC | |
| 5 | 146-018 | J1 | CONNECTOR, RECT RECP, 10 SOC | |
| 6 | 146-316 | J6 | CONNECTOR, RECT RECP, 3 SOC | |
| 11 | 171-007 | | TERMINAL LUG, RING, NO. 10, 16-14 AWG | |
| 12 | 171-178 | | TERMINAL LUG, RING, NO. 10, 22-18 AWG | |
| 18 | 591-140 | | CORD, FAN | |

E

| ITEM NO. | AMPEX PART NO. | REFERENCE NUMBER | DESCRIPTION | JEDEC NO. OR MFR. PART NO. |
|----------|----------------|------------------|--------------------------------------------------|----------------------------|
| | 4020403-04 | | TRANSPORT CONTROL CHASSIS ASSEMBLY (NHA 4010240) | |
| 2 | 4041206-03 | | COVER, CHASSIS, TRANSPORT CONTROL | |
| 3 | 4050692-06 | | CAPSTAN SERVO PWA | |
| 5 | 4050808-04 | | SEARCH-TO-CUE/TIMER PWA | |
| 6 | 4050790-01 | | TRANSPORT CONTROL HARNESS ASSEMBLY | |
| 13 | 169-318 | | KEY, POLARIZING, PWB, REF: J1,2,4 | |
| 14 | 471-070 | | SCREW, PAN HD, XREC, NO. 6-32 X 0.438 LG | |
| 16 | 471-071 | | SCREW, PAN HD, XREC, NO. 6-32 X 0.500 LG | |
| 18 | 471-061 | | SCREW, PAN HD, XREC, NO. 4-40 X 0.438 LG | |
| 19 | 471-069 | | SCREW, PAN HD, XREC, NO. 6-32 X 0.375 LG | |
| 20 | 496-005 | | NUT, KEP, NO. 6-32 | |
| 21 | 501-008 | | WASHER, FLAT, NO. 4 | |
| 22 | 501-009 | | WASHER, FLAT, NO. 6 | |
| 23 | 502-024 | | WASHER, LOCK, INT STAR, NO. 4 | |
| 24 | 502-025 | | WASHER, LOCK, INT STAR, NO. 6 | |
| 26 | 530-159 | | GUIDE, PWB | |
| 27 | 302-365 | | STRAP, CABLE | |
| 28 | 4290945-03 | | PANEL, CONNECTOR, TRANSPORT CONTROL CHASSIS | |
| 29 | 4290896-06 | | CHASSIS, TRANSPORT CONTROL | |
| 30 | 4050864-01 | | TRANSPORT CONTROL PWA | |
| 36 | 4840402 | | SCHEMATIC | |

P

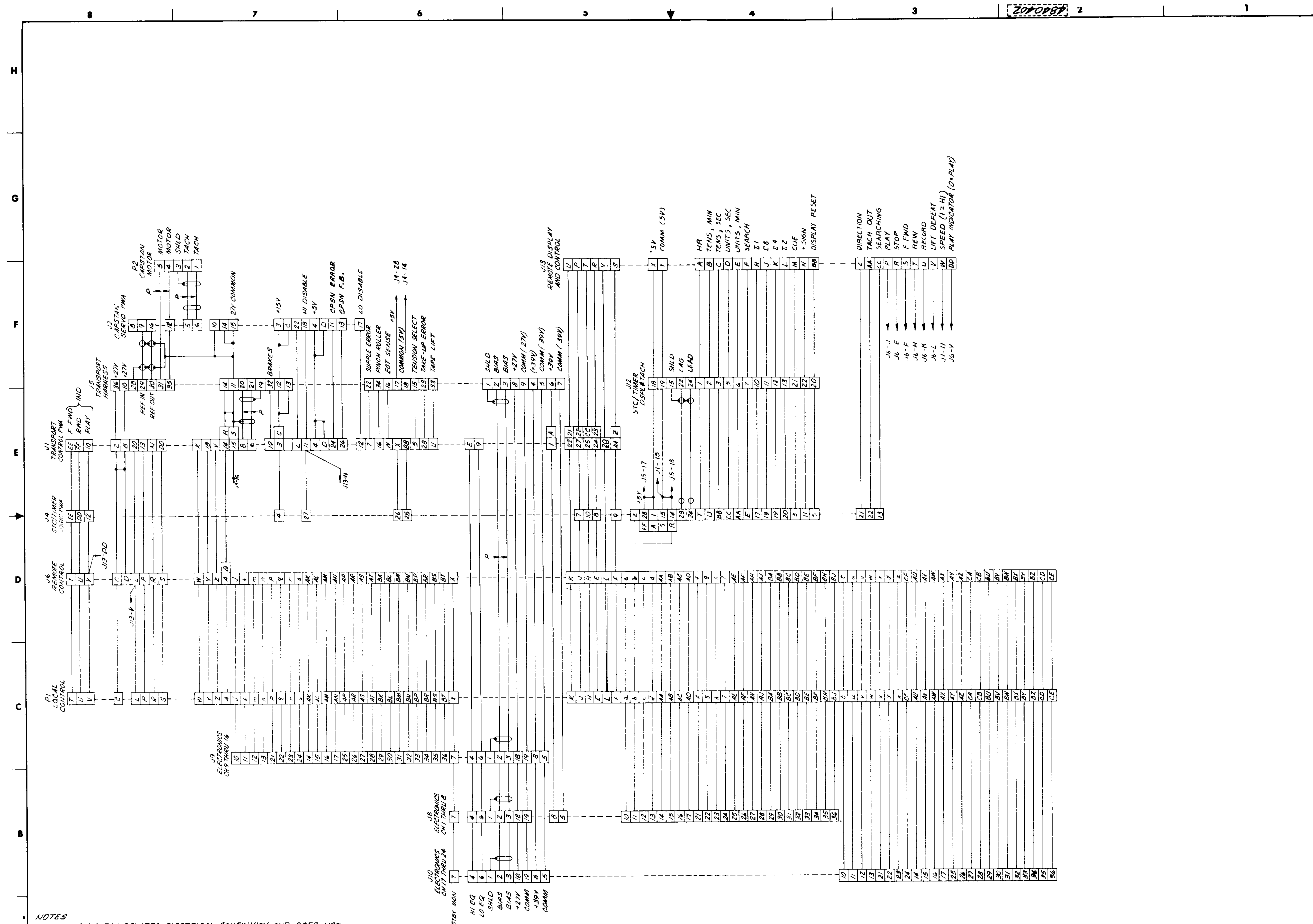

NOTES
 1 THIS DIAGRAM DENOTES ELECTRICAL CONTINUITY AND DOES NOT NECESSARILY REPRESENT POINT TO POINT CONNECTIONS.

Wiring Diagram No. 4840402D.
 Transport Control Chassis Assembly

| ITEM NO. | AMPEX PART NO. | REFERENCE NUMBER | DESCRIPTION | JEDEC NO. OR MFR. PART NO. |
|----------|----------------|-------------------|------------------------------------------|----------------------------|
| | 4050692-06 | | CAPSTAN SERVO PWA (NHA 4020403) | |
| 2 | 4840356 | | SCHEMATIC | |
| 4 | 52528-01 | | HANDLE, SNAP-ON | |
| 6 | 013-678 | CR1 | DIODE | 1N4005 |
| 7 | 013-983 | VR1 | DIODE | 1N752A |
| 8 | 013-599 | CR2,3,4,5 | DIODE | 1N914 |
| 9 | 014-652 | Q3,7 | TRANSISTOR | 2N3906 |
| 10 | 014-698 | Q1,2,6,8 | TRANSISTOR | 2N3536 |
| 11 | 014-793 | | PAD, MTG, TRANSISTOR, REF: Q1,2,6,7,8 | |
| 12 | 280-130 | | PAD, MTG, TRANSISTOR, REF: Q3 | |
| 13 | 017-122 | Y1 | CRYSTAL | |
| 14 | 037-459 | C23 | CAPACITOR, TANT, 1.0 UF, 35V, 10% | |
| 15 | 030-057 | C2,3,6-8,15,16,19 | CAPACITOR, CER, DISC, 0.01 UF, 100V, 20% | |
| 16 | 030-437 | C1,9 | CAPACITOR, MONO, 0.1 UF, 25V | |
| 17 | 055-156 | C14 | CAPACITOR, MYLAR, 0.22 UF, 50V, 5% | |
| 18 | 055-195 | C18 | CAPACITOR, MYLAR, 0.0068 UF, 50V, 5% | |
| 19 | 041-411 | R2,18 | RESISTOR, COMP, 47K, 1/4W, 5% | |
| 20 | 034-283 | C22 | CAPACITOR, MICA, 820 PF, 300V, 5% | |
| 22 | 035-853 | C13 | CAPACITOR, MYLAR, 0.056 UF, 50V, 5% | |
| 24 | 035-596 | C11 | CAPACITOR, MYLAR, 0.082 UF, 50V, 5% | |
| 25 | 041-408 | R4,9,10,11,32 | RESISTOR, COMP, 10K, 1/4W, 5% | |
| 26 | 037-367 | C17,20 | CAPACITOR, TANT, 2.2 UF, 20V, 10% | |
| 27 | 037-620 | C5 | CAPACITOR, TANT, 100 UF, 20V, 10% | |
| 28 | 037-894 | C4,21 | CAPACITOR, TANT, 100 UF, 10V, 20% | |
| 29 | 041-482 | R37 | RESISTOR, COMP, 12K, 1/4W, 5% | |
| 31 | 041-407 | R7,8,27,34 | RESISTOR, COMP, 3.3K, 1/4W, 5% | |
| 33 | 041-410 | R5,15,30 | RESISTOR, COMP, 1K, 1/4W, 5% | |
| 35 | 041-412 | R14 | RESISTOR, COMP, 4.7K, 1/4W, 5% | |
| 37 | 041-443 | R1 | RESISTOR, COMP, 39K, 1/4W, 5% | |
| 38 | 041-483 | R35 | RESISTOR, COMP, 27K, 1/4W, 5% | |
| 39 | 041-495 | R3 | RESISTOR, COMP, 8.2K, 1/4W, 5% | |
| 40 | 041-502 | R26 | RESISTOR, COMP, 240 OHM, 1/4W, 5% | |
| 41 | 041-503 | R6 | RESISTOR, COMP, 270 OHM, 1/4W, 5% | |
| 42 | 041-504 | R25 | RESISTOR, COMP, 510 OHM, 1/4W, 5% | |
| 44 | 041-530 | R29 | RESISTOR, COMP, 15 OHM, 1/4W, 5% | |
| 45 | 041-409 | R36 | RESISTOR, COMP, 15K, 1/4W, 5% | |
| 46 | 041-394 | R33,39 | RESISTOR, COMP, 100K, 1/4W, 5% | |
| 47 | 041-653 | R31 | RESISTOR, COMP, 39 OHM, 1/4W, 5% | |
| 48 | 055-133 | C10 | CAPACITOR, MYLAR, 0.0022 UF, 50V, 5% | |
| 49 | 055-168 | C12 | CAPACITOR, MYLAR, 0.0056 UF, 50V, 5% | |
| 50 | 041-562 | R28 | RESISTOR, COMP, 43K, 1/4W, 5% | |
| 52 | 041-427 | R38 | RESISTOR, COMP, 330 OHM, 1/4W, 5% | |
| 53 | 058-754 | R19 | RESISTOR, VAR, CER, 100 OHM, 1W, 20% | |
| 54 | 143-981 | E1-6 | JACK, CLOSED ENTRY | |
| 55 | 150-106 | | BRACKET, MTG, CRYSTAL, REF: Y1 | |
| 56 | 166-628 | | PLUG, SHORTING BLOCK, BLK | |
| 57 | 041-393 | R44 | RESISTOR, COMP, 1M, 1/4W, 5% | |
| 58 | 471-062 | | SCREW, PAN HD, XREC, NO. 4-40 X 0.375 LG | |
| 59 | 492-008 | | NUT, PLAIN, HEX, NO. 4-40 | |
| 60 | 501-008 | | WASHER, FLAT, NO. 4 | |
| 61 | 502-024 | | WASHER, LOCK, NO. 4 | |
| 64 | 580-332 | | HEATSINK, REF: Q5 | |
| 65 | 580-395 | Q4,5 | TRANSISTOR | 2N5190 |
| 66 | 058-498 | R45 | RESISTOR, VAR, CER, 500 OHM, 1/2W, 20% | |
| 67 | 057-137 | R12,13,16,17 | RESISTOR, MF, 51K, 1/4W, 2% | |
| 68 | 586-153 | A7 | INTEGRATED CIRCUIT | MC846P |
| 69 | 586-268 | A4 | INTEGRATED CIRCUIT | UA741C |

H

SHEET 1 OF 2

| ITEM NO. | AMPEX PART NO. | REFERENCE NUMBER | DESCRIPTION | JEDEC NO. OR MFR. PART NO. |
|----------|----------------|------------------|------------------------------|----------------------------|
| 70 | 586-283 | A1 | INTEGRATED CIRCUIT | SN7493N |
| 71 | 586-309 | A10 | INTEGRATED CIRCUIT | U6A9601 |
| 72 | 586-425 | A2,3 | INTEGRATED CIRCUIT | MC853P |
| 73 | 586-698 | A6,8,9 | INTEGRATED CIRCUIT | U6A9950 |
| 74 | 587-086 | A5 | INTEGRATED CIRCUIT | LM311N |
| 75 | 586-680 | A11 | INTEGRATED CIRCUIT | SN7413J |
| 76 | 057-108 | R41 | RESISTOR, MF, 3.3K, 1/4W, 2% | |
| 77 | 057-110 | R42 | RESISTOR, MF, 3.9K, 1/4W, 2% | |
| 78 | 057-115 | R22,23 | RESISTOR, MG, 6.2K, 1/4W, 2% | |
| 79 | 057-129 | R20 | RESISTOR, MF, 24K, 1/4W, 2% | |
| 80 | 057-134 | R21 | RESISTOR, MF, 39K, 1/4W, 2% | |
| 81 | 057-141 | R43 | RESISTOR, MG, 75K, 1/4W, 2% | |

H

SHEET 2 OF 2

TABLE 1

| SPEED STRAPPING | | | |
|-----------------|----------|----------|----------|
| RANGE | HI | MED | LO |
| HI | E5 TO E6 | E5 TO E3 | E5 TO E4 |
| LO | E2 TO E3 | E2 TO E4 | E2 TO E1 |

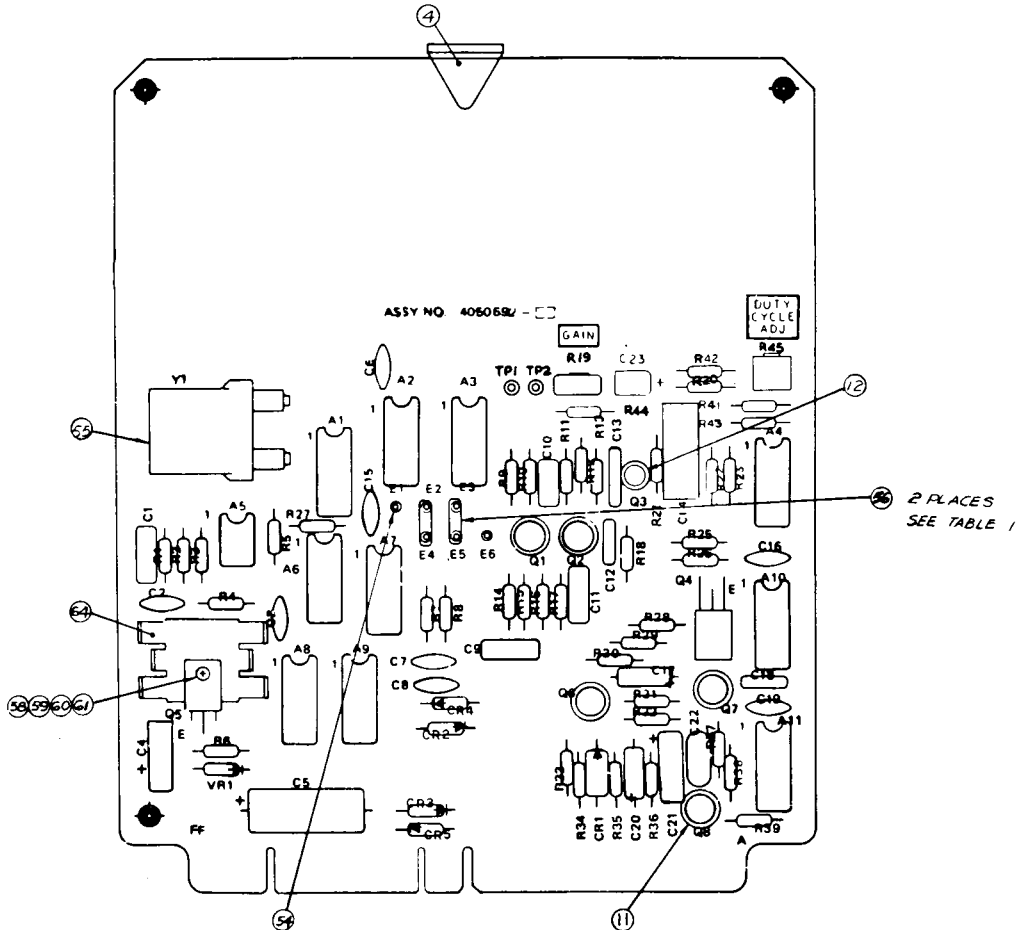

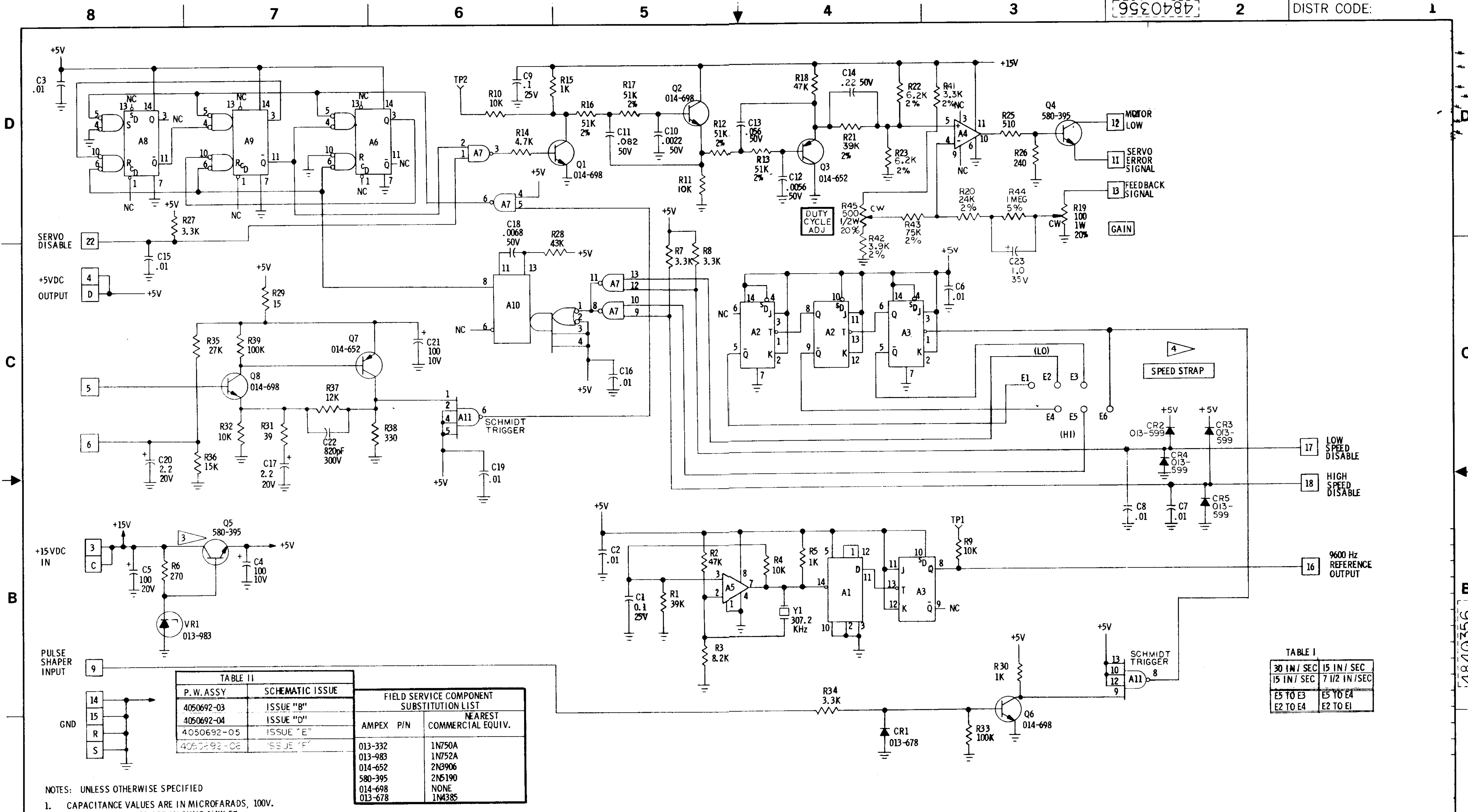

| TABLE II | | FIELD SERVICE COMPONENT SUBSTITUTION LIST | |
|------------|-----------------|-------------------------------------------|---------------------------|
| P.W. ASSY | SCHEMATIC ISSUE | AMPEX P/N | NEAREST COMMERCIAL EQUIV. |
| 4050692-03 | ISSUE "B" | 013-332 | 1N750A |
| 4050692-04 | ISSUE "D" | 013-983 | 1N752A |
| 4050692-05 | ISSUE "E" | 014-652 | 2N3906 |
| 4050692-06 | ISSUE "F" | 580-395 | 2N5190 |
| | | 014-698 | NONE |
| | | 013-678 | 1N4385 |

| | |
|-------------|----------------|
| 30 IN / SEC | 15 IN / SEC |
| 15 IN / SEC | 7 1/2 IN / SEC |
| E5 TO E3 | E5 TO E4 |
| E2 TO E4 | E2 TO E1 |

- NOTES: UNLESS OTHERWISE SPECIFIED
- CAPACITANCE VALUES ARE IN MICROFARADS, 100V.
 - RESISTANCE VALUES ARE IN OHMS 1/4W, 5%.
 - HEATSINK REQUIRED.
 - SEE TABLE I FOR SPEED STRAPPING.

| REFERENCE DESIGNATION | | I.C. LIST | | | | | | | | |
|-----------------------|----------|-----------------------|---------|----------|---------|---------|---------|---------|---------|---------|
| LAST USED | NOT USED | REFERENCE DESIGNATION | A11 | A6, 8, 9 | A7 | A4 | A1 | A2, 3 | A5 | A10 |
| A11 | Q8 | AMPEX P/N | 586-680 | 586-698 | 586-153 | 586-268 | 586-283 | 586-425 | 587-086 | 586-309 |
| C23 | Y1 | VENDOR P/N | SN7413J | U6A9950 | MC 846P | UA 741C | SN7493N | MC 853P | LM-311N | U6A9601 |
| R45 | CR5 | VOLTAGE PIN | 14 | 14 | 14 | 11 | 5 | 14 | 8 | 14 |
| TP2 | E6 | GROUND PIN | 7 | 7 | 7 | 6 | 10 | 7 | 4, 1 | 7 |
| VRL | | | | | | | | | | |

Schematic No. 4840356F.
Capstan Servo PWA

| ITEM NO. | AMPEX PART NO. | REFERENCE NUMBER | DESCRIPTION | JEDEC NO. OR MFR. PART NO. |
|----------|----------------|-----------------------------|-----------------------------------------------|----------------------------|
| | 4050864-01 | | TRANSPORT CONTROL PWA (NHA 4020403) | |
| 3 | 52528-01 | | HANDLE, SNAP-ON | |
| 5 | 4840438 | | SCHEMATIC | |
| 7 | 013-599 | CR1-22 | DIODE | 1N914 |
| 8 | 013-983 | VR1 | DIODE | 1N752A |
| 9 | 581-298 | VR2 | DIODE | 1N4757A |
| 11 | 014-247 | Q19,20,23-25 | TRANSISTOR | 2N2219 |
| 12 | 014-248 | Q1-5,8-17 | TRANSISTOR | 2N2222 |
| 13 | 014-383 | Q21,22 | TRANSISTOR | 2N2484 |
| 14 | 014-781 | Q18 | TRANSISTOR | MPS6518-5 |
| 15 | 580-156 | Q6,7 | TRANSISTOR | 2N5461 |
| 16 | 580-464 | Q31,32 | TRANSISTOR | MJE1090 |
| 17 | 580-467 | Q26-30 | TRANSISTOR | MJE1100 |
| 19 | 056-163 | C15 | CAPACITOR, MICA, 470 PF, 500V, 5% | |
| 20 | 034-153 | C19-23 | CAPACITOR, MICA, 1000 PF, 500V, 5% | |
| 22 | 055-166 | C17 | CAPACITOR, MYLAR, 0.001 UF, 50V, 5% | |
| 23 | 030-057 | C3-5,6,9,10,13,14, 18,24-26 | CAPACITOR, CER, 0.01 UF, 100V, 20% | |
| 24 | 035-883 | C16 | CAPACITOR, MYLAR, 0.068 UF, 50V, 5% | |
| 25 | 037-899 | C7 | CAPACITOR, TANT, 0.1 UF, 35V, 20% | |
| 26 | 037-790 | C27 | CAPACITOR, TANT, 2.2 UF, 20V, 20% | |
| 27 | 037-109 | C11,12 | CAPACITOR, TANT, 10 UF, 20V, 10% | |
| 28 | 037-936 | C8 | CAPACITOR, TANT, 22 UF, 35V, 20% | |
| 29 | 037-945 | C1,2 | CAPACITOR, TANT, 27 UF, 25V, 20% | |
| 30 | 037-938 | R30-30 | CAPACITOR, TANT, 33 UF, 35V, 20% | |
| 31 | 049-559 | R37 | RESISTOR, COMP, 120 OHM, 1/4W, 5% | |
| 32 | 041-396 | R35,36 | RESISTOR, COMP, 220 OHM, 1/4W, 5% | |
| 33 | 041-560 | R9,24,47,51 | RESISTOR, COMP, 2K, 1/4W, 5% | |
| 34 | 041-413 | R49,53 | RESISTOR, COMP, 6.8K, 1/4W, 5% | |
| 35 | 041-408 | R30,50,54 | RESISTOR, COMP, 10K, 1/4W, 5% | |
| 36 | 041-428 | R20 | RESISTOR, COMP, 470 OHM, 1/4W, 5% | |
| 38 | 041-409 | R25,38-46 | RESISTOR, COMP, 15K, 1/4W, 5% | |
| 39 | 041-508 | R21 | RESISTOR, COMP, 20K, 1/4W, 5% | |
| 40 | 041-483 | R12,48,52 | RESISTOR, COMP, 27K, 1/4W, 5% | |
| 41 | 041-518 | R26,32 | RESISTOR, COMP, 33K, 1/4W, 5% | |
| 42 | 041-394 | R16,17 | RESISTOR, COMP, 100K, 1/4W, 5% | |
| 43 | 041-432 | R27,28 | RESISTOR, COMP, 220K, 1/4W, 5% | |
| 44 | 041-469 | R33 | RESISTOR, COMP, 330K, 1/4W, 5% | |
| 45 | 041-772 | R29 | RESISTOR, COMP, 1.2M, 1/4W, 5% | |
| 46 | 041-774 | R31 | RESISTOR, COMP, 1.5M, 1/4W, 5% | |
| 48 | 041-528 | R13,22 | RESISTOR, COMP, 300 OHM, 1/2W, 5% | |
| 49 | 041-336 | R18,19 | RESISTOR, COMP, 470 OHM, 1/2W, 5% | |
| 50 | 041-501 | R23 | RESISTOR, COMP, 330 OHM, 1W, 5% | |
| 52 | 075-128 | R1-4,10,14,14 | RESISTOR, VAR, CER, 10K, 1/2W, 10% | |
| 53 | 075-129 | R5,6,7,8,11 | RESISTOR, VAR, CER, 5K, 1/2W, 10% | |
| 54 | 075-131 | R34 | RESISTOR, VAR, CER, 1M, 1/2W, 10% | |
| 57 | 586-268 | A11,12 | INTEGRATED CIRCUIT | UA741 |
| 58 | 586-795 | A19 | INTEGRATED CIRCUIT | MC665P |
| 59 | 587-101 | A2,9,14 | INTEGRATED CIRCUIT | MC661P |
| 60 | 587-102 | A1,3,6-8,10,15, 17,18 | INTEGRATED CIRCUIT | MC668P |
| 61 | 587-103 | A4,5,13,16 | INTEGRATED CIRCUIT | MC680P |
| 63 | 280-998 | | PAD, MTG, TRANSISTOR, T0-5, REF: Q19,20,23-25 | |
| 64 | 280-130 | | PAD, MTG, TRANSISTOR, T0-18, T0-92 | |

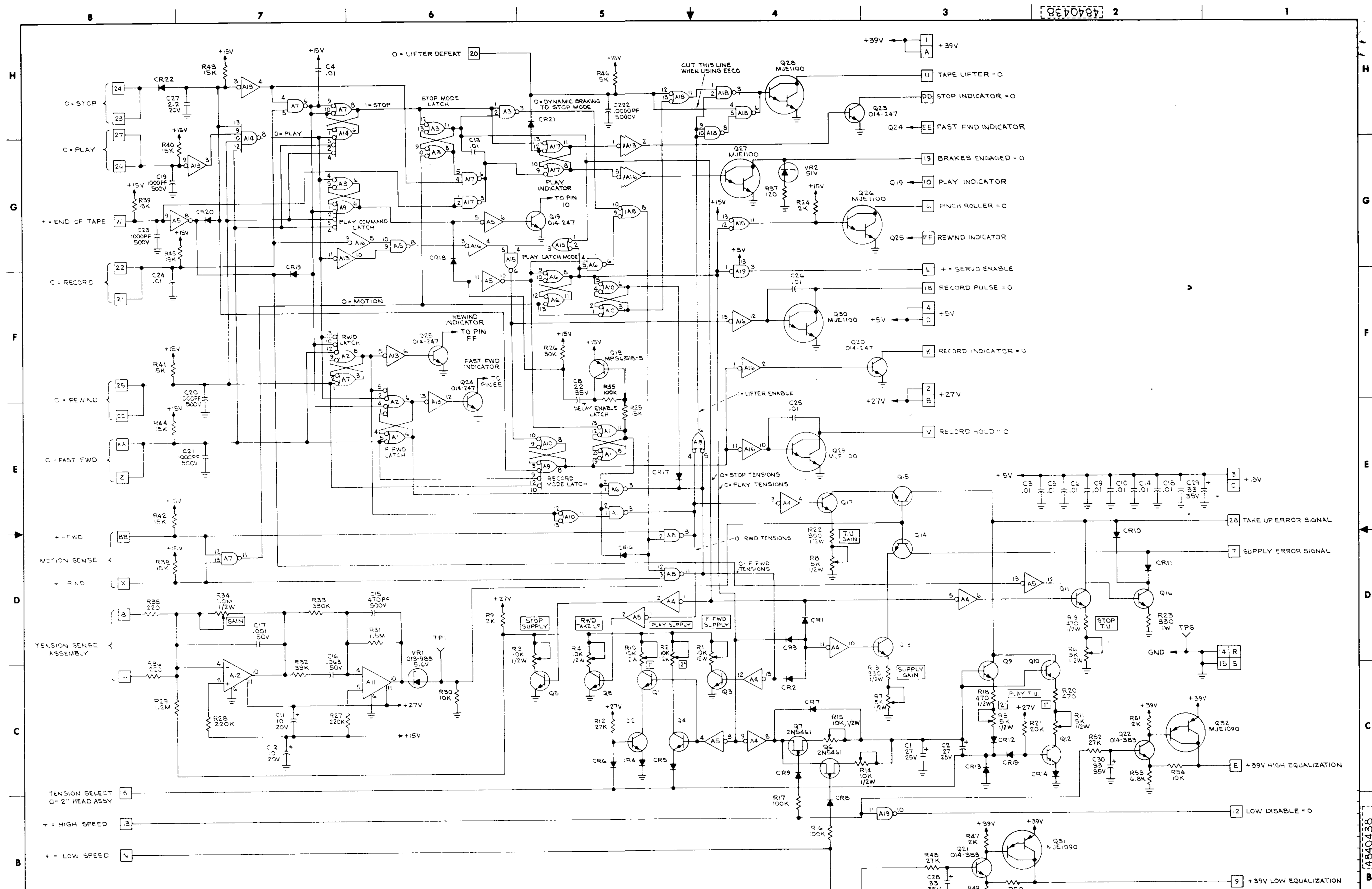

NOTES: UNLESS OTHERWISE SPECIFIED

1. RESISTANCE VALUES ARE IN OHMS, 1/4W, ±5%.
2. CAPACITANCE VALUES ARE IN MICROFARADS, 50V.
3. DIODES ARE PART NUMBER 03-599.
4. TRANSISTORS ARE PART NUMBER 04-248.
5. I.W. ASSY NO. 405064-02.

| FIELD SERVICE SUBSTITUTION LIST | |
|---------------------------------|-------------------------|
| AMPEX PART NUMBER | NEAREST COMM EQUIVALENT |
| 013-599 | IN914 |
| 013-983 | IN752A |
| 581-295 | IN4757A |
| 014-247 | 2N2219 |
| 014-248 | 2N2222 |
| 014-383 | 2N2484 |
| 014-781 | MP5651B-5 |
| 580-156 | 2N5461 |
| 580-464 | MJE1090 |
| 580-467 | MJE1100 |

| REFERENCE DESIGNATIONS | |
|------------------------|----------|
| LAST USED | NOT USED |
| A9 | C7 |
| CR22 | |
| Q32 | |
| R55 | |
| TP1, G | |
| VR2 | |

| I.C. LIST | | | | | |
|------------------------|---------------|---------|------------|---------|---------|
| REFERENCE DESIGNATIONS | A1,3,4,7,8,10 | A2,9,14 | A4,5,13,16 | A11,12 | A19 |
| AMPEX P/N | 587-102 | 587-101 | 587-103 | 586-248 | 586-795 |
| VENDOR P/N | MCG6BP | MCG6IP | MCG6BP | UA741 | MCG6SP |
| VOLTAGE PIN | 14 | 14 | 14 | 11 | 14 |
| GROUND PIN | 7 | 7 | 7 | 6 | 7 |

Schematic No. 4840438B.
Transport Control PWA

| ITEM NO. | AMPEX PART NO. | REFERENCE NUMBER | DESCRIPTION | JEDEC NO. OR MFR. PART NO. |
|----------|----------------|--------------------------------|----------------------------------------------|----------------------------|
| | 4050808-04 | | SEARCH-TO-CUE/TIMER PWA (NHA 4020403) | |
| 2 | 4120032-01 | | HANDLE, STC BD | |
| 5 | 013-257 | VR1,2 | DIODE | 1N753A |
| 6 | 055-168 | C21 | CAPACITOR, MYLAR, 0.0056 UF, 50V, 5% | |
| 7 | 013-650 | CR1,2,5,6,7,8,9 | DIODE | HP2190 |
| 10 | 030-963 | C25 | CAPACITOR, CER, 0.1 UF, 100V, 10% | |
| 11 | 056-163 | C11 | CAPACITOR, MICA, 470 PF, 500V, 5% | |
| 12 | 035-828 | C4,5 | CAPACITOR, MYLAR, 0.022 UF, 50V, 5% | |
| 13 | 037-298 | C2,3 | CAPACITOR, TANT, 47 UF, 6V, 20% | |
| 14 | 037-591 | C6,7,22,24,29 | CAPACITOR, TANT, 1 UF, 35V, 20% | |
| 16 | 037-893 | C17,19 | CAPACITOR, TANT, 15 UF, 20V, 20% | |
| 17 | 037-936 | C27 | CAPACITOR, TANT, 22 UF, 35V, 20% | |
| 18 | 037-954 | C8,23,26,30 | CAPACITOR, TANT, 22 UF, 15V, 20% | |
| 19 | 049-520 | R20, 40 | RESISTOR, COMP, 470 OHM, 1/4W, 10% | |
| 20 | 041-638 | R62,66 | RESISTOR, COMP, 3.3K, 1/4W, 10% | |
| 21 | 041-626 | R9,13,55 | RESISTOR, COMP, 100K, 1/4W, 10% | |
| 22 | 041-630 | R8,10,12,15 | RESISTOR, COMP, 22K, 1/4W, 10% | |
| 23 | 041-633 | R7,11,14,16,17,39,56,67 | RESISTOR, COMP, 10K, 1/4W, 10% | |
| 25 | 041-642 | R5,6,57 | RESISTOR, COMP, 330 OHM, 1/4W, 10% | |
| 27 | 049-356 | R47,56 | RESISTOR, COMP, 470K, 1/4W, 10% | |
| 28 | 049-373 | R52 | RESISTOR, COMP, 56K, 1/4W, 10% | |
| 29 | 049-371 | R42,51,61,64,65 | RESISTOR, COMP, 33K, 1/4W, 10% | |
| 30 | 049-394 | R63 | RESISTOR, COMP, 10 OHM, 1/4W, 10% | |
| 31 | 041-636 | R41,60 | RESISTOR, COMP, 4.7K, 1/4W, 10% | |
| 32 | 057-132 | R44 | RESISTOR, MF, 33K, 1/4W, 2% | |
| 33 | 057-122 | R2,26-31 | RESISTOR, MF, 12K, 1/4W, 2% | |
| 34 | 057-129 | R1,3,4,32,33,34,35,36,37,50,53 | RESISTOR, MF, 24K, 1/4W, 2% | |
| 35 | 057-133 | R48,54 | RESISTOR, MF, 36K, 1/4W, 2% | |
| 36 | 057-147 | R49 | RESISTOR, MF, 130K, 1/4W, 2% | |
| 37 | 058-610 | R68 | RESISTOR, VAR, CER, 20K, 1/2W, 20% | |
| 38 | 064-116 | C1,9,10,12-16,18,20,28,31 | CAPACITOR, CER, DISC, 0.01 UF, 50V, +80%-20% | |
| 39 | 066-001 | R45 | RESISTOR, MF, 22.6K, 1/8W, 1% | |
| 40 | 066-005 | R46 | RESISTOR, MF, 25.5K, 1/8W, 1% | |
| 41 | 143-981 | | JACK, CLOSED ENTRY | |
| 42 | 166-628 | | PLUG, SHORTING BLOCK | |
| 43 | 267-078 | | INSULATOR, MTG, VERT | |
| 44 | 057-120 | R43 | RESISTOR, COMP, 10K, 1/4W, 2% | |
| 45 | 049-333 | R58 | RESISTOR, COMP, 100 OHM, 1/4W, 10% | |
| 46 | 586-075 | A15,24 | INTEGRATED CIRCUIT | 7400N |
| 47 | 586-077 | A13,14 | INTEGRATED CIRCUIT | 7420N |
| 48 | 586-078 | A6 | INTEGRATED CIRCUIT | 7430N |
| 49 | 586-108 | A5,10,29 | INTEGRATED CIRCUIT | 7474N |
| 50 | 586-109 | A11,12 | INTEGRATED CIRCUIT | 7402N |
| 51 | 587-147 | A1 | INTEGRATED CIRCUIT | 7414N |
| 52 | 586-153 | A4 | INTEGRATED CIRCUIT | MC846P |
| 53 | 586-303 | A16,17 | INTEGRATED CIRCUIT | 9328DC |
| 54 | 586-326 | A22,34 | INTEGRATED CIRCUIT | 7404N |
| 56 | 586-450 | A7 | INTEGRATED CIRCUIT | 74164N |
| 57 | 586-554 | A18 | INTEGRATED CIRCUIT | 7483N |
| 58 | 586-705 | A21 | INTEGRATED CIRCUIT | 7486N |
| 59 | 586-797 | A31 | INTEGRATED CIRCUIT | 74123N |
| 60 | 586-871 | A2 | INTEGRATED CIRCUIT | 7413N |
| 62 | 586-925 | A23 | INTEGRATED CIRCUIT | 74175N |

F

| ITEM NO. | AMPEX PART NO. | REFERENCE NUMBER | DESCRIPTION | JEDEC NO. OR MFR. PART NO. |
|----------|----------------|--------------------------|------------------------------------------|----------------------------|
| 63 | 586-906 | A3,9,20,26,32 | INTEGRATED CIRCUIT | 74191 |
| 64 | 586-759 | A33 | INTEGRATED CIRCUIT | 7408N |
| 65 | 587-051 | A27 | INTEGRATED CIRCUIT | 7425N |
| 66 | 587-266 | A30 | INTEGRATED CIRCUIT | 74279N |
| 67 | 587-458 | A28 | INTEGRATED CIRCUIT | LM324N |
| 68 | 586-890 | A8,19 | INTEGRATED CIRCUIT | 7417N |
| 69 | 280-130 | | PAD, MTG, TRANSISTOR | |
| 70 | 471-069 | | SCREW, PAN HD, XREC, NO. 6-32 X 0.375 LG | |
| 71 | 501-009 | | WASHER, PLAIN, NO. 6 | |
| 72 | 502-025 | | WASHER, LOCK, IT, NO. 6 | |
| 73 | 586-713 | A25 | INTEGRATED CIRCUIT | 7407N |
| 74 | 492-009 | | NUT, HEX, NO. 6-32 | |
| 76 | 041-979 | R18,19,21,22,23,24,35,38 | RESISTOR, COMP, 1K, 1/4W, 10% | |
| 77 | 014-698 | Q1-4,6 | TRANSISTOR | 2N3536 |
| 78 | 014-248 | Q5 | TRANSISTOR | 2N2222 |
| 81 | 4840417 | | SCHEMATIC | F |

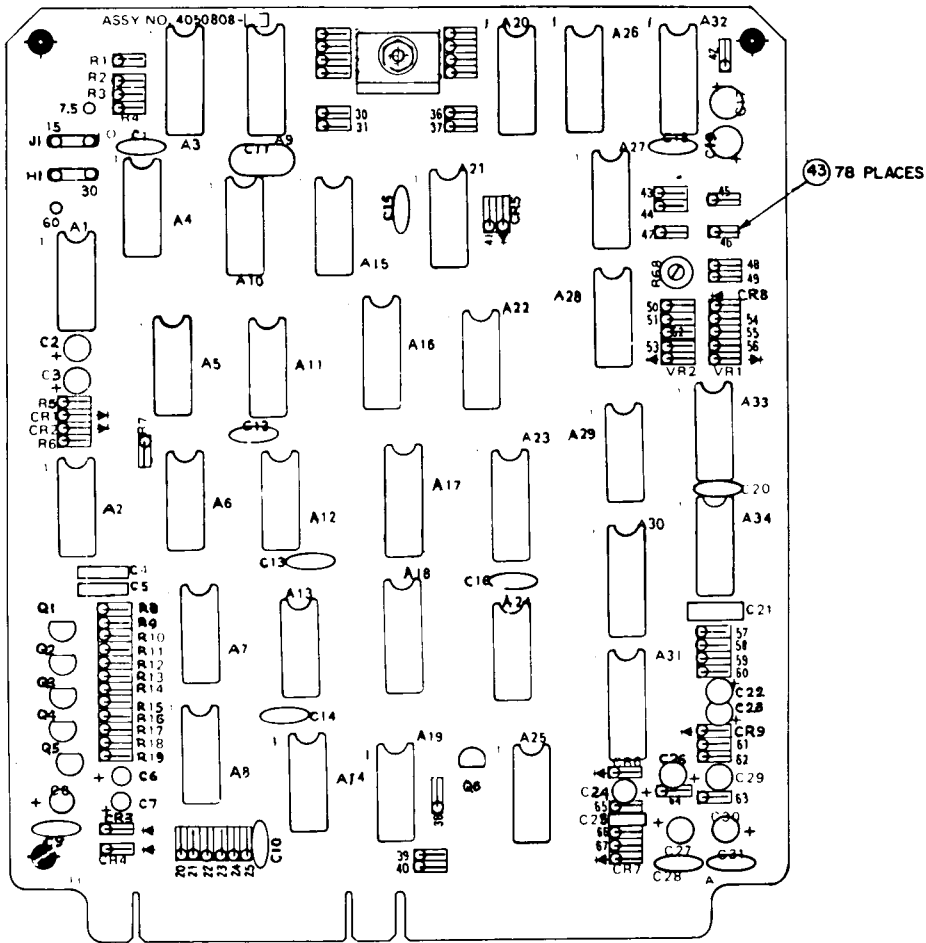

| ITEM NO. | AMPEX PART NO. | REFERENCE NUMBER | DESCRIPTION | JEDEC NO. OR MFR. PART NO. |
|----------|----------------|------------------|--------------------------------------------------|----------------------------|
| | 4050790-01 | | TRANSPORT CONTROL HARNESS ASSEMBLY (NHA 4020403) | |
| 1 | 143-804 | J1,2,4 | CONNECTOR, PWB, 56 PIN DUAL | |
| 2 | 4330354-01 | | PLATE, ADAPTER | |
| 3 | 146-257 | P1 | CONNECTOR, PLUG, 104 CONTACT | |
| 4 | 146-258 | J6 | CONNECTOR, RECPT, 104 CONTACT | |
| 6 | 143-120 | J13 | CONNECTOR, RECPT, 26 CONTACT | BURNDY |
| 7 | 166-225 | | CONTACT, SOC, 16-18 AWG, REF: J8,9,10 | |
| 10 | 166-224 | | CONTACT, SOC, 24-26 AWG, REF: J8,9,10,13 | |
| 11 | 166-199 | J8,9,10,13 | CONTACT, CONN, SOC, 20-22 AWG | BURNDY |
| 12 | 167-022 | P2 | CONNECTOR, PLUG, 6 PIN | BURNDY |
| 13 | 167-029 | J5,8,9,10 | CONNECTOR, RECPT, 36 SOC | BURNDY |
| 14 | 167-365 | | CONTACT, CONN, PIN, REF: J12 | VIKING |
| 15 | 167-239 | J12 | CONNECTOR, PWB, RECPT, 24 PIN | VIKING |
| 16 | 169-076 | | CONTACT, CONN, SOC, 20 AWG, REF: P1, J6 | |
| 17 | 169-085 | | CONTACT, CONN, SOC, 24 AWG, REF: P1, J6 | |
| 18 | 262-007 | | BUSHING, FLANGED, 0.75 ID RUBBER, REF: P1 | |
| 19 | 166-227 | | CONTACT, PIN, 16-18 AWG, REF: J5 | |
| 20 | 166-200 | | CONTACT, PIN, 20-22 AWG, REF: J5, P2 | |
| 21 | 166-226 | | CONTACT, PIN, 24-26 AWG, REF: J5, P2 | |
| 50 | 4840402 | | SCHEMATIC | |

H

SHEET 1 OF 1

| ITEM NO. | AMPEX PART NO. | REFERENCE NUMBER | DESCRIPTION | JEDEC NO. OR MFR. PART NO. |
|----------|----------------------------------------|------------------|---------------------------------------------------------------------------------------------------------------------------------------------------|----------------------------|
| | 4020394-04 4020394-05 4020394-06 | | CONTROL BOX ASSEMBLY, 8 CHANNEL (NHA 4010240) CONTROL BOX ASSEMBLY, 16 CHANNEL (NHA 4010240) CONTROL BOX ASSEMBLY, 24 CHANNEL (NHA 4010240) | |
| 7 | 4600089-01 | | SHIELD, LIGHT, 16, 24 CHANNEL | |
| 8 | 4050854-01 | | STANDBY SWITCHER CONTROL BOX PWA | |
| 9 | 4100077-01 | | BUTTON, "RECORD" | |
| 10 | 4100077-02 | | BUTTON, "REWIND" | |
| 11 | 4100077-03 | | BUTTON, "PLAY" | |
| 12 | 4100077-04 | | BUTTON, "STOP" | |
| 13 | 4100077-05 | | BUTTON, "FAST FWD" | |
| 14 | 4100077-07 | | BUTTON, "LIFT DEFEAT" | |
| 17 | 4110279-04 | | OVERLAY, CONTROL BOX, 8 CHANNEL | |
| 18 | 4110279-05 | | OVERLAY, CONTROL BOX, 16 CHANNEL | |
| 19 | 4110279-06 | | OVERLAY, CONTROL BOX, 24 CHANNEL | |
| 23 | 4041211-02 | | BRACKET ASSY, CONNECTOR | |
| 26 | 4330330-01 | | PLATE | |
| 27 | 4330331-01 | | BASE | |
| 33 | 060-350 | | LAMP, 28V, INCANDESCENT | NO. 385 |
| 34 | 250-165 | | BUMPER, RUBBER | |
| 35 | 280-888 | | SPACER, THD, HEX, 0.250 A, FLATS, NO. 6-32 X 0.125 LG | |
| 36 | 280-428 | | SPACER, THD, HEX, 0.250 A, FLATS, NO. 4-40 X 0.750 LG | |
| 37 | 302-395 | | STRAP, CABLE | |
| 38 | 310-740 | | CATCH ASSEMBLY | |
| 39 | 472-113 | | SCREW, PAN HD, XREC, NO. 2-56 X 0.25 LG | |
| 41 | 471-061 | | SCREW, PAN HD, XREC, NO. 4-40 X 0.312 LG | |
| 42 | 471-062 | | SCREW, PAN HD, XREC, NO. 4-40 X 0.375 LG | |
| 44 | 471-328 | | SCREW, FLAT HD, NO. 4-40 X 0.375 LG | |
| 45 | 470-017 | | SCREW, CAP, HEX SOC, NO. 6-32 X 0.312 LG | |
| 46 | 502-374 | | WASHER, LOCK, HELICAL SPRING, NO. 6 | |
| 47 | 492-009 | | NUT, PLAIN, HEX, NO. 6 | |
| 48 | 501-155 | | WASHER, PLAIN, NO. 2 | |
| 49 | 501-008 | | WASHER, PLAIN, NO. 4 | |
| 50 | 501-009 | | WASHER, PLAIN, NO. 6 | |
| 51 | 502-002 | | WASHER, LOCK, HELICAL SPRING, NO. 4 | |
| 52 | 502-003 | | WASHER, LOCK, HELICAL SPRING, NO. 6 | |
| 56 | 4050773-01 | | CONNECTOR HARNESS ASSEMBLY, 8 CHANNEL | |
| 57 | 4050773-02 | | CONNECTOR HARNESS ASSEMBLY, 16 CHANNEL | |
| 58 | 4050773-03 | | CONNECTOR HARNESS ASSEMBLY, 24 CHANNEL | |
| 59 | 502-001 | | WASHER, LOCK, HELICAL SPRING, NO. 2 | |
| 65 | 4050756-04 | | LED BOARD PWA, 8 CHANNEL | |
| 66 | 4050756-05 | | LED BOARD, PWA, 16 CHANNEL | |
| 67 | 4050756-06 | | LED BOARD, PWA, 24 CHANNEL | |
| 68 | 4050757-04 | | SWITCH BOARD, PWA, 8 CHANNEL | |
| 69 | 4050757-05 | | SWITCH BOARD, PWA, 16 CHANNEL | |
| 70 | 4050757-06 | | SWITCH BOARD, PWA, 24 CHANNEL | |
| 80 | 4840430 | | SCHEMATIC | |

N

SHEET 1 OF 1

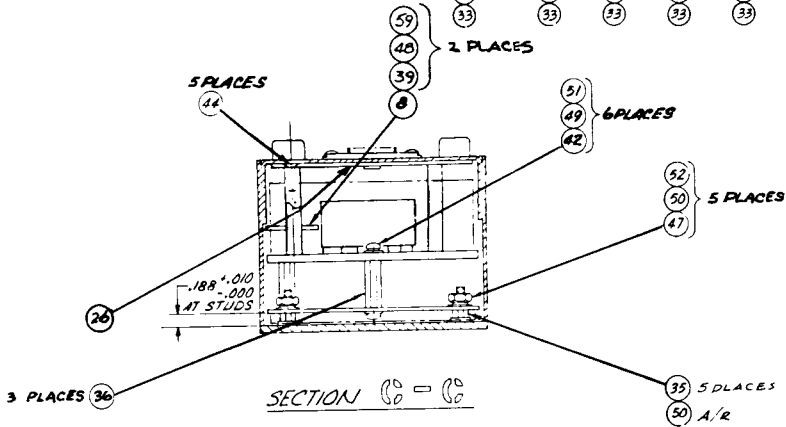
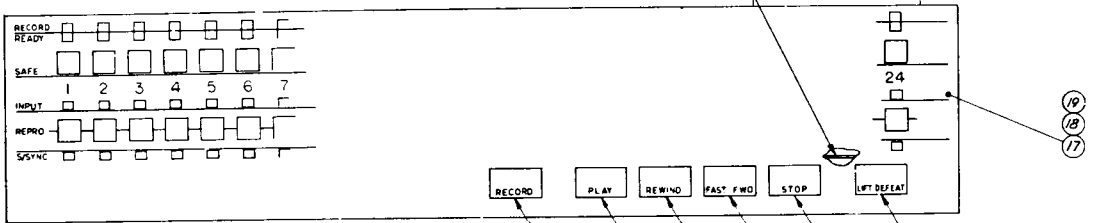
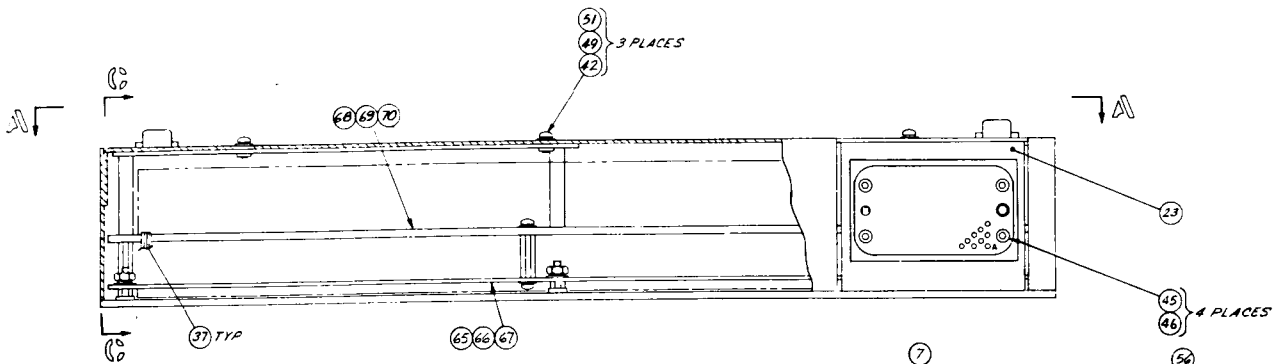
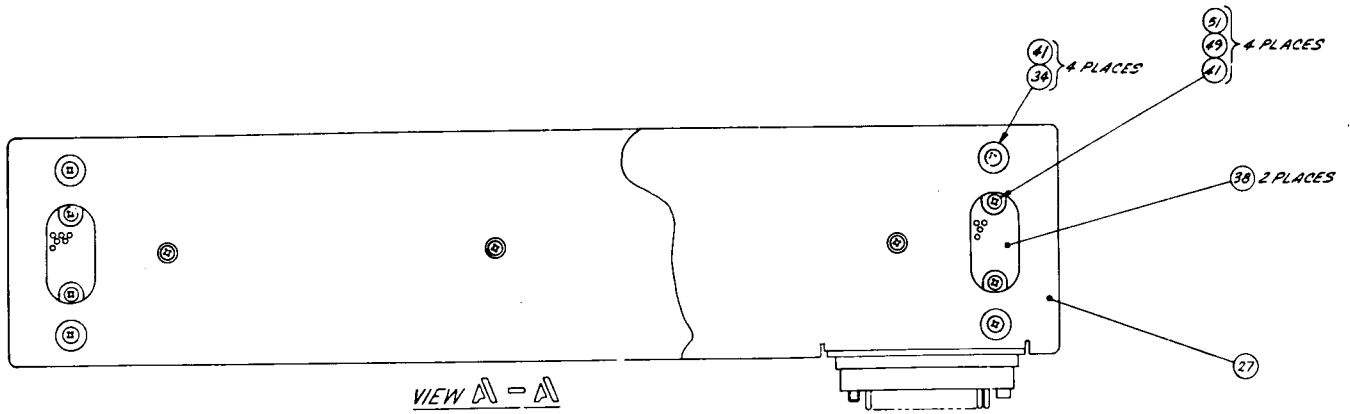

Assembly No. 4020394. Control Box Assembly

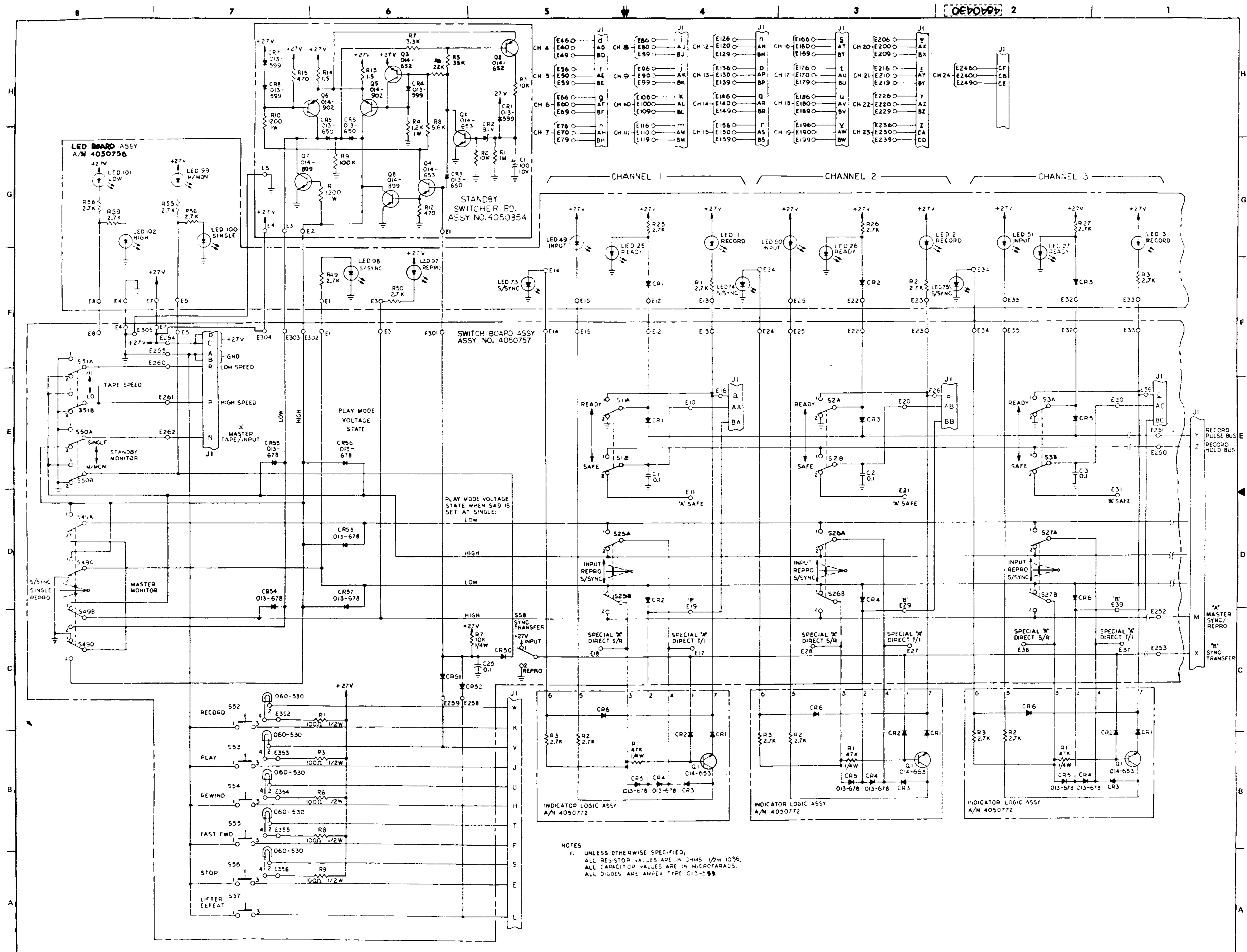

Schematic No. 4840430B.
Control Box Assembly

| ITEM NO. | AMPEX PART NO. | REFERENCE NUMBER | DESCRIPTION | JEDEC NO. OR MFR. PART NO. |
|----------|----------------------------------------|----------------------------------|------------------------------------------------------------------------------------------------------------------------------|----------------------------|
| | 4050756-04 4050756-05 4050756-06 | | LED BOARD PWA, 8 CHANNEL (NHA 4020394) LED BOARD PWA, 16 CHANNEL (NHA 4020394) LED BOARD PWA, 24 CHANNEL (NHA 4020394) | |
| 10 | 581-400 | LED 1-8, 97,98 | DIODE, LIGHT EMITTING, 8 CHANNEL, RED | HP5082-4684 |
| 11 | 581-400 | LED1-16, 97,98 | DIODE, LIGHT EMITTING, 16 CHANNEL, RED | HP5082-4684 |
| 12 | 581-400 | LED 1-24, 97,98 | DIODE, LIGHT EMITTING, 24 CHANNEL, RED | HP5082-4684 |
| 14 | 581-399 | LED 25-32,49-56, 73-80,99-102 | DIODE, LIGHT EMITTING, 8 CHANNEL, YELLOW | HP5082-4584 |
| 15 | 581-399 | LED 25-40,49-64, 73-88,99-102 | DIODE, LIGHT EMITTING, 16 CHANNEL, YELLOW | HP5082-4584 |
| 16 | 581-399 | LED 25-96,99-102 | DIODE, LIGHT EMITTING, 24 CHANNEL, YELLOW | HP5082-4584 |
| 26 | 013-599 | CR1-8 | DIODE, 8 CHANNEL | 1N914 |
| 27 | 013-599 | CR1-16 | DIODE, 16 CHANNEL | 1N914 |
| 28 | 013-599 | CR1-24 | DIODE, 24 CHANNEL | 1N914 |
| 30 | 041-053 | R1-8,25-32,49,50, 55,56,58,59 | RESISTOR, COMP, 2.7K, 1/2W, 10%, 8 CHANNEL | |
| 31 | 041-053 | R1-16,25-40,49,50 55,56,58,59 | RESISTOR, COMP, 2.7K, 1/2W, 10%, 16 CHANNEL | |
| 32 | 041-053 | R1-50,55,56,58,59 | RESISTOR, COMP, 2.7K, 1/2W, 10%, 24 CHANNEL | |
| 33 | 4840430 | | SCHEMATIC | |

B

SHEET 1 OF 1

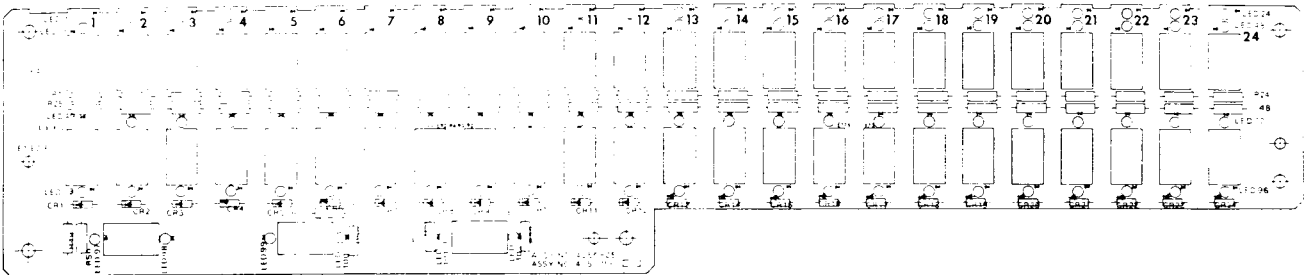

| ITEM NO. | AMPEX PART NO. | REFERENCE NUMBER | DESCRIPTION | JEDEC NO. OR MFR. PART NO. |
|----------|----------------------------------------|------------------|------------------------------------------------------------------------------------------------------------------------------------|----------------------------|
| | 4050757-04 4050757-05 4050757-06 | | SWITCHBOARD PWA, 8 CHANNEL (NHA 4020394) SWITCHBOARD PWA, 16 CHANNEL (NHA 4020394) SWITCHBOARD PWA, 24 CHANNEL (NHA 4020394) | |
| 3 | 013-599 | CR1-16,50,51,52 | DIODE, 8 CHANNEL | 1N914 |
| 4 | 013-599 | CR1-32,50,51,52 | DIODE, 16 CHANNEL | 1N914 |
| 5 | 013-599 | CR1-48,50,51,52 | DIODE, 24 CHANNEL | 1N914 |
| 8 | 013-678 | CR53-57 | DIODE | 1N4005 |
| 13 | 030-963 | C1-8,25 | CAPACITOR, CER, 0.1 UF, 100V, 10%, 8 CHANNEL | |
| 14 | 030-963 | C1-16,25 | CAPACITOR, CER, 0.1 UF, 100V, 10%, 16 CHANNEL | |
| 15 | 030-963 | C1-25 | CAPACITOR, CER, 0.1UF, 100V, 10%, 24 CHANNEL | |
| 16 | 041-003 | R1,3,6,8,9 | RESISTOR, COMP, 100 OHM, 1/2W, 5% | |
| 22 | 119-339 | S52-57 | SWITCH, PUSHBUTTON | OAK 585 |
| 23 | 119-426 | S58 | SWITCH, SLIDE, SPDT | |
| 24 | 119-341 | S49 | SWITCH, 4PDT | C & K 7411 |
| 25 | 119-342 | S25-32 | SWITCH, DPDT, 8 CHANNEL | C & K 7211 |
| 26 | 119-342 | S25-40 | SWITCH, DPDT, 16 CHANNEL | C & K 7211 |
| 27 | 119-342 | S25-48 | SWITCH, DPDT, 24 CHANNEL | C & K 7211 |
| 28 | 119-340 | S1-8,50,51 | SWITCH, DPDT, 8 CHANNEL | C & K 7201 |
| 29 | 119-340 | S1-16,50,51 | SWITCH, DPDT, 16 CHANNEL | C & K 7201 |
| 30 | 119-340 | S1-24,50,51 | SWITCH, DPDT, 24 CHANNEL | C & K 7201 |
| 31 | 041-630 | R7 | RESISTOR, COMP, 22K, 1/4W, 10% | |
| 32 | 472-113 | | SCREW, PAN HD, XREC, NO. 2-56 X 0.250 LG | |
| 33 | 472-451 | | SCREW, PAN HD, XREC, NO. 2-56 X 0.188 LG | |
| 34 | 280-878 | | SPACER, THRD, NO. 2-56 X 0.437 LG, REF: S50,51 | |
| 35 | 280-879 | | SPACER, THRD, NO. 2-56 X 0.500 LG, REF: S49 | |
| 37 | 4840430 | | SCHEMATIC | |
| 38 | 4260496-01 | | BAR, MTG, SWITCH | |
| 40 | 4050772-01 | | INDICATOR LOGIC PWA | |
| 51 | 121-223 | | NUT, HEX, SWITCH | |
| 52 | 121-224 | | SPACER, 1/16 INCH, SWITCH | |
| 53 | 121-225 | | WASHER, LOCK, SWITCH | |
| 55 | 280-162 | | SPACER, UNTHD, 0.119 ID X 0.250 OD X 0.250 LG | |
| 56 | 471-115 | | SCREW, PAN HD, XREC, NO. 4-40 X 0.625 LG | |
| 57 | 501-562 | | WASHER, NYLON, 0.115 ID X 0.281 OD X 0.047 THK | |
| 60 | 283-083 | | STANDOFF, MALE-FEMALE, HEX BODY, NO. 2-46 X 0.68 LG | |

G

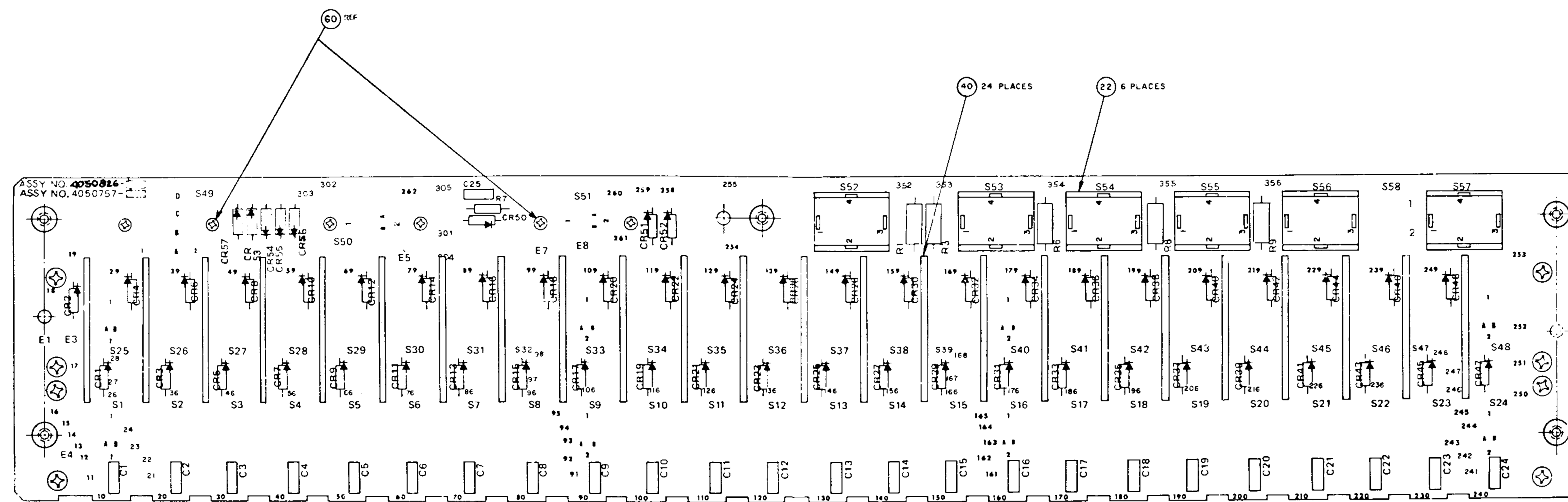
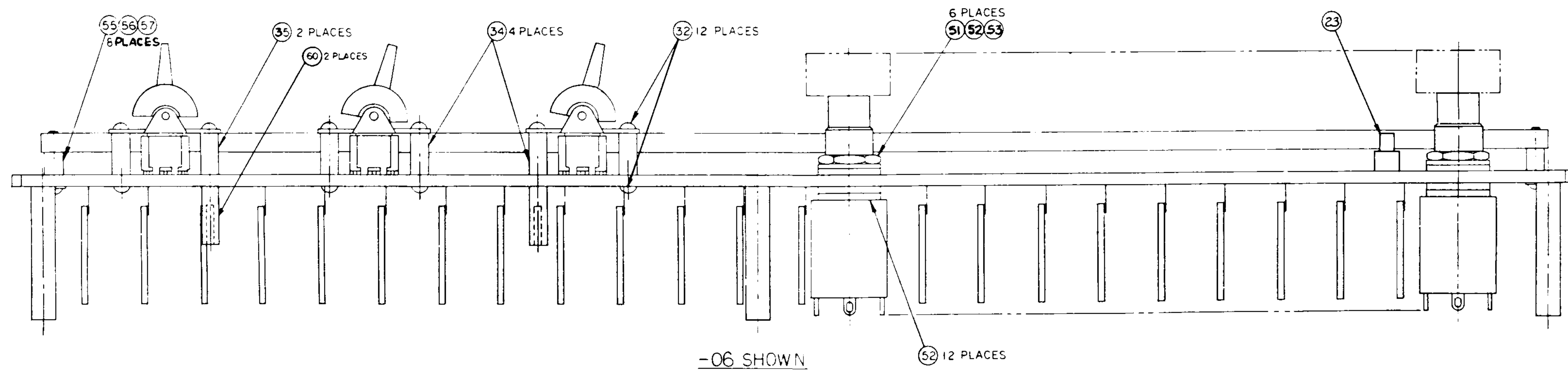
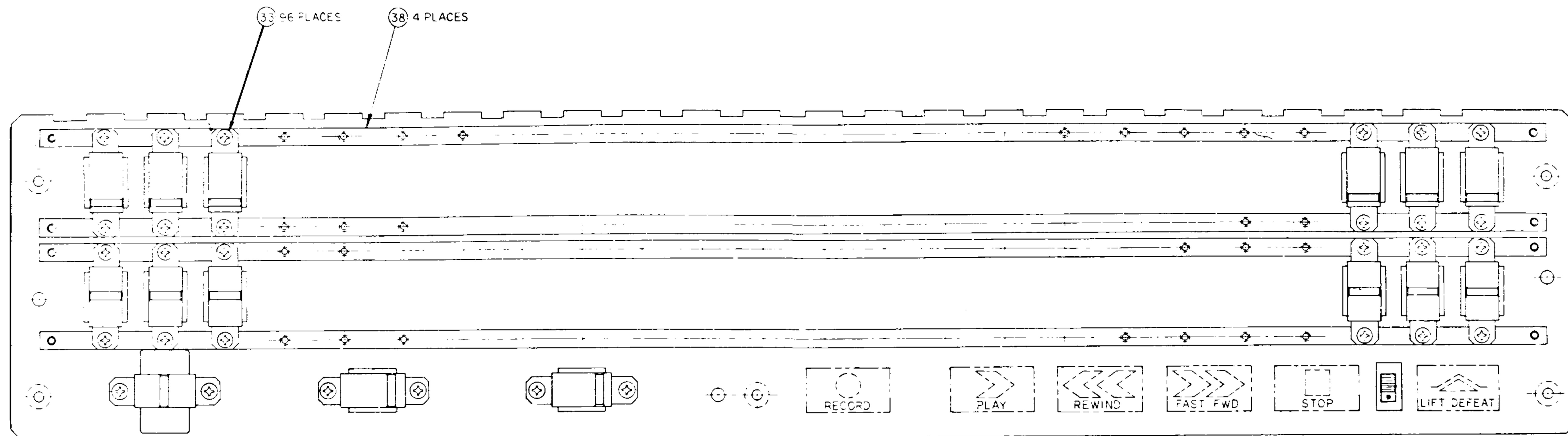

Assembly No. 4050757.
Switchboard PWA

| ITEM NO. | AMPEX PART NO. | REFERENCE NUMBER | DESCRIPTION | JEDEC NO. OR MFR. PART NO. |
|----------|----------------|------------------|-----------------------------------|----------------------------|
| | 4050772-01 | | INDICATOR LOGIC PWA (NHA 4050757) | |
| 4 | 013-599 | CR1,2,3,6 | DIODE | 1N914 |
| 5 | 013-678 | CR4,5 | DIODE | 1N4005 |
| 7 | 014-653 | Q1 | TRANSISTOR | 2N3904 |
| 9 | 041-053 | R2,3 | RESISTOR, COMP, 2.7K, 1/2W, 10% | |
| 10 | 041-411 | R1 | RESISTOR, COMP, 47K, 1/4W, 5% | |
| 36 | 4840430 | | SCHEMATIC | |

SHEET 1 OF 1

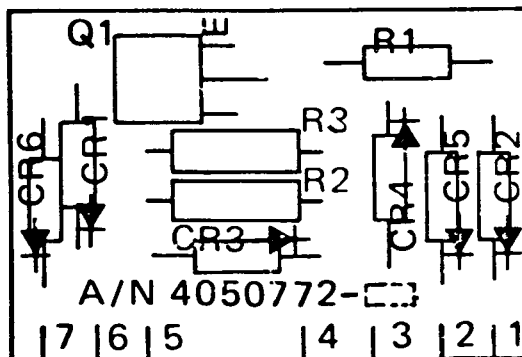

| ITEM NO. | AMPEX PART NO. | REFERENCE NUMBER | DESCRIPTION | JEDEC NO. OR MFR. PART NO. |
|----------|----------------|------------------|---------------------------------------------------|----------------------------|
| | 4050854-01 | | STANDBY SWITCHER CONTROL BOX PWA (NHA 4020394) | |
| 2 | 014-652 | Q2,3 | TRANSISTOR | 2N3906 |
| 3 | 014-653 | Q1,4 | TRANSISTOR | 2N3904 |
| 4 | 014-899 | Q7,8 | TRANSISTOR | MJE521 |
| 5 | 014-902 | Q5,6 | TRANSISTOR | MJE371 |
| 9 | 013-599 | CR1,4,7,8 | DIODE | 1N914 |
| 10 | 013-650 | CR3,5,6 | DIODE | 1N270 |
| 11 | 013-383 | CR2 | DIODE | 1N757A |
| 14 | 037-643 | C1 | CAPACITOR, TANT, 100 UF, 10V, 10% | |
| 17 | 041-428 | R12,15 | RESISTOR, CARBON, 470 OHM, 1/4W, 5% | |
| 18 | 041-407 | R7 | RESISTOR, CARBON, 3.3K, 1/4W, 5% | |
| 19 | 041-507 | R8 | RESISTOR, CARBON, 5.6K, 1/4W, 5% | |
| 20 | 041-408 | R2,3 | RESISTOR, CARBON, 10K, 1/4W, 5% | |
| 21 | 041-406 | R6 | RESISTOR, CARBON, 22K, 1/4W, 5% | |
| 22 | 041-518 | R5 | RESISTOR, CARBON, 33K, 1/4W, 5% | |
| 23 | 041-394 | R9 | RESISTOR, CARBON, 100K, 1/4W, 5% | |
| 24 | 041-393 | R1 | RESISTOR, CARBON, 1M, 1/4W, 5% | |
| 27 | 041-355 | R4,10,11 | RESISTOR, CARBON, 1200 OHM, 1W, 5% | |
| 29 | 049-584 | R13,14 | RESISTOR, CARBON, 1.5 OHM, 1/2W, 5% | |
| 32 | 471-062 | | SCREW, PAN HD, XREC, NO. 4-40 X 3/8 INCH LG | |
| 33 | 501-710 | | WASHER, NYLON, F LAT, NO. 4 | |
| 34 | 501-169 | | WASHER, FLAT, NO. 4 | |
| 35 | 496-004 | | NUT, KEP, NO. 4-32 | |
| 37 | 4840430 | | SCHEMATIC | |

SHEET 1 OF 1

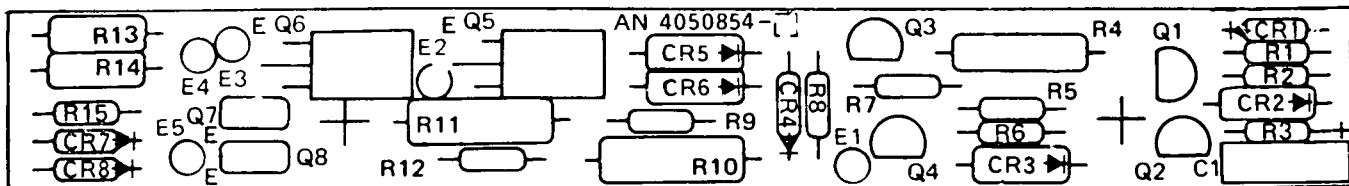

| ITEM NO. | AMPEX PART NO. | REFERENCE NUMBER | DESCRIPTION | JEDEC NO. OR MFR. PART NO. |
|----------|----------------|------------------|-----------------------------------------------------------------------------------------------------------------------------------------------------------------------------------------------------------------|----------------------------|
| | 4050773-01 | | CONTROL BOX CONNECTOR HARNESS ASSEMBLY 8 CHANNEL (NHA 4020394) CONTROL BOX CONNECTOR HARNESS ASSEMBLY, 16 CHANNEL (NHA 4020394) CONTROL BOX CONNECTOR HARNESS ASSEMBLY, 24 CHANNEL (NHA 4020394) | |
| | 4050773-02 | | | |
| | 4050773-03 | | | |
| 5 | 169-143 | | PIN, CONTACT, NO. 22 AWG PIN, CONTACT, NO. 24 AWG PIN, CONTACT, NO. 16 AWG CONNECTOR, 104 POS STRAP, CABLE, 1.25 DIAM STRAP, CABLE, 0.75 DIAM | |
| 6 | 169-086 | | | |
| 7 | 169-077 | | | |
| 8 | 160-273 | | | |
| 11 | 302-379 | | | |
| 12 | 302-335 | | | |

E

| ITEM NO. | AMPEX PART NO. | REFERENCE NUMBER | DESCRIPTION | JEDEC NO. OR MFR. PART NO. |
|----------|----------------|------------------|--------------------------------------------------|----------------------------|
| | 4030351-01 | | CONSOLE FRAME ASSEMBLY (NHA 4010240) | |
| 1 | 4120072-01 | | CATCH, PADDLE LATCH | |
| 2 | 4150349-04 | | CONSOLE MODIFICATION | |
| 4 | 4220121-01 | | SPACER, MODIFIED | |
| 5 | 4260532-02 | | BRACKET, CABLE TIE | |
| 6 | 4260491-02 | | BRACKET, MTG, MDA | |
| 7 | 4260502-02 | | MOUNTING, ANGLE, REAR | |
| 8 | 4260526-01 | | BRACKET, DOOR HINGE, LEFT | |
| 9 | 4260526-02 | | BRACKET, DOOR HINGE, RIGHT | |
| 10 | 4260532-02 | | BRACKET, CABLE TIE | |
| 11 | 4290798-01 | | PANEL, BOTTOM | |
| 12 | 4290814-02 | | PANEL, CONNECTOR, REMOTE CONTROL | |
| 14 | 4330333-01 | | PLATE, MTG, BRIDGE | |
| 15 | 4330353-01 | | PLATE, DOOR HINGE | |
| 16 | 4420059-01 | | NUTPLATE, HINGE | |
| 17 | 4130061-01 | | BUMPER, FRAME, CONSOLE | |
| 19 | 082-056 | | CASTER, SWIVEL | |
| 20 | 082-057 | | CASTER, FIXED | |
| 22 | 302-443 | | STRAP, CABLE | |
| 23 | 470-036 | | SCREW, CAP, HEX SOC HD, 10-32 X 3/8 LG | |
| 24 | 471-093 | | SCREW, PAN HD, XREC, 10-32 X 1 IN LG | |
| 25 | 473-331 | | SCREW, PAN HD, XREC, SEM, 6-32 X 1/2 LG | |
| 26 | 476-240 | | SCREW, THREAD FORMING, NO. 8 X 0.375 LG | |
| 27 | 470-038 | | SCREW, CAP, HEX SOC HD, 10-32 X 1/2 LG | |
| 28 | 480-096 | | SCREW, BOLT, HEX HD, 1/4-20 X 3/4 LG | |
| 29 | 496-007 | | NUT, KEP, 10-32 | |
| 30 | 496-009 | | NUT, KEP, 1/4-20 | |
| 31 | 497-190 | | NUT, SPRING, 10-32 | |
| 33 | 501-009 | | WASHER, NO. 6 | |
| 34 | 501-011 | | WASHER, NO. 10 | |
| 35 | 501-012 | | WASHER, 1/4 | |
| 36 | 501-205 | | WASHER, PLAIN, NO. 8 | |
| 37 | 501-702 | | WASHER, FINISHING, NYLON, BLACK, NO. 10 | |
| 39 | 471-078 | | SCREW, PAN HD, XREC, 8-32 X 3/8 LG | |
| 40 | 471-089 | | SCREW, PAN HD, XREC, 10-32 X 1/2 LG | |
| 41 | 471-093 | | SCREW, PAN HD, XREC, 10-32 X 1.0 LG | |
| 42 | 472-578 | | SCREW, OVAL HD, XREC, NK L PLTD, 10-32 X 0.75 LG | |
| 43 | 496-005 | | NUT, KEP, 6-32 | |
| 44 | 496-006 | | NUT, KEP, 8-32 | |
| 45 | 502-003 | | WASHER, LOCK, 6-32 | |
| 47 | 502-102 | | WASHER, LOCK, 1/4 | |

H

SHEET 1 OF 1

| ITEM NO. | AMPEX PART NO. | REFERENCE NUMBER | DESCRIPTION | JEDEC NO. OR MFR. PART NO. |
|----------|----------------|------------------|---------------------------------------------|----------------------------|
| | 4030370-02 | | POWER SWITCH HOUSING ASSEMBLY (NHA 4010240) | |
| 3 | 145-013 | | CONNECTOR, PLUG, 8 PIN, LOCK CAP | |
| 4 | 260-005 | | GROMMET | |
| 5 | 119-350 | | SWITCH, TOGGLE, DPST | |
| 6 | 471-117 | | SCREW, PAN HD, XREC, 6-32 X 0.31 LG | |
| 7 | 501-015 | | WASHER, PLAIN, NO. 6 | |
| 8 | 502-009 | | WASHER, LOCK, SPLIT, NO. 6 | |
| 11 | 121-212 | | WASHER, KEYING | |
| 12 | 4260501-03 | | BRACKET, POWER SWITCH | |
| 13 | 4290810-03 | | HOUSING, POWER SWITCH | |

SHEET 1 OF 1

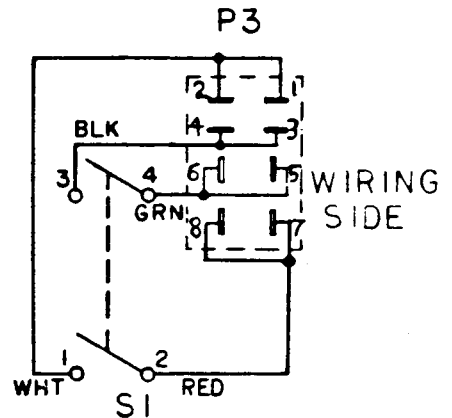
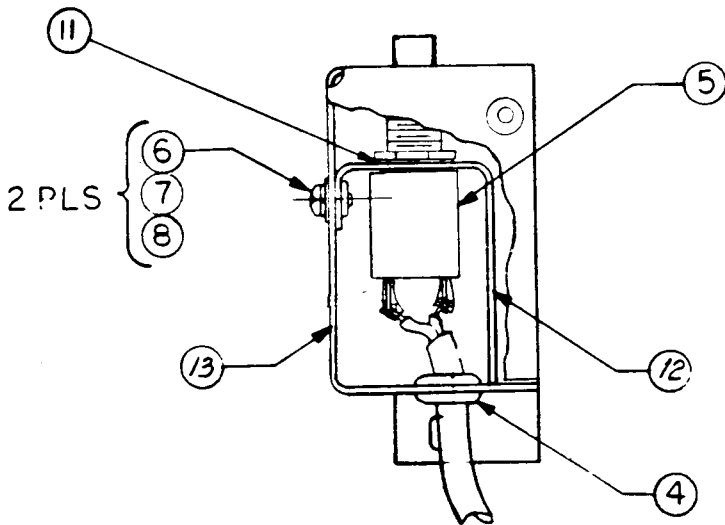
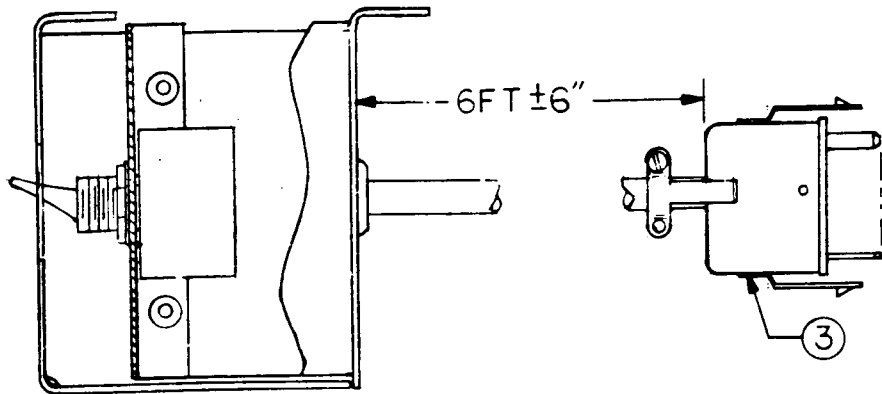

WIRING DIAGRAM

| ITEM NO. | AMPEX PART NO. | REFERENCE NUMBER | DESCRIPTION | JEDEC NO. OR MFR. PART NO. |
|----------|----------------|--------------------------------|--------------------------------------|----------------------------|
| | 4030419-01 | | FAN PANEL ASSEMBLY (NHA 4010240) | |
| 1 | 4041273-02 | TB6 | PANEL, FAN | ROTON WHISPER |
| 2 | 1374158-01 | | FILTER | |
| 4 | 171-001 | | TERMINAL LUG | |
| 5 | 180-815 | | STRIP, MARKER | |
| 6 | 180-970 | | STRIP, TERMINAL | |
| 7 | 180-142 | | JUMPER, TERMINAL | |
| 9 | 471-072 | B1,2,3 | SCREW, PAN HD, XREC, 6-32 X 0.625 LG | |
| 10 | 471-339 | | SCREW, FLAT HD, 6-32 X 0.625 LG | |
| 12 | 492-034 | | NUT, HEX, SMALL PAT, 6-32 | |
| 13 | 496-005 | | NUT, KEP, NO. 6 | |
| 15 | 501-009 | WASHER, FLAT, NO. 6 | | |
| 16 | 501-188 | WASHER, FLAT, SMALL PAT, NO. 6 | | |
| 17 | 502-003 | WASHER, LOCK, SPRING, NO. 6 | | |
| 20 | 591-053 | FAN | | |
| 21 | 591-140 | CORD, POWER | | |

SHEET 1 OF 1

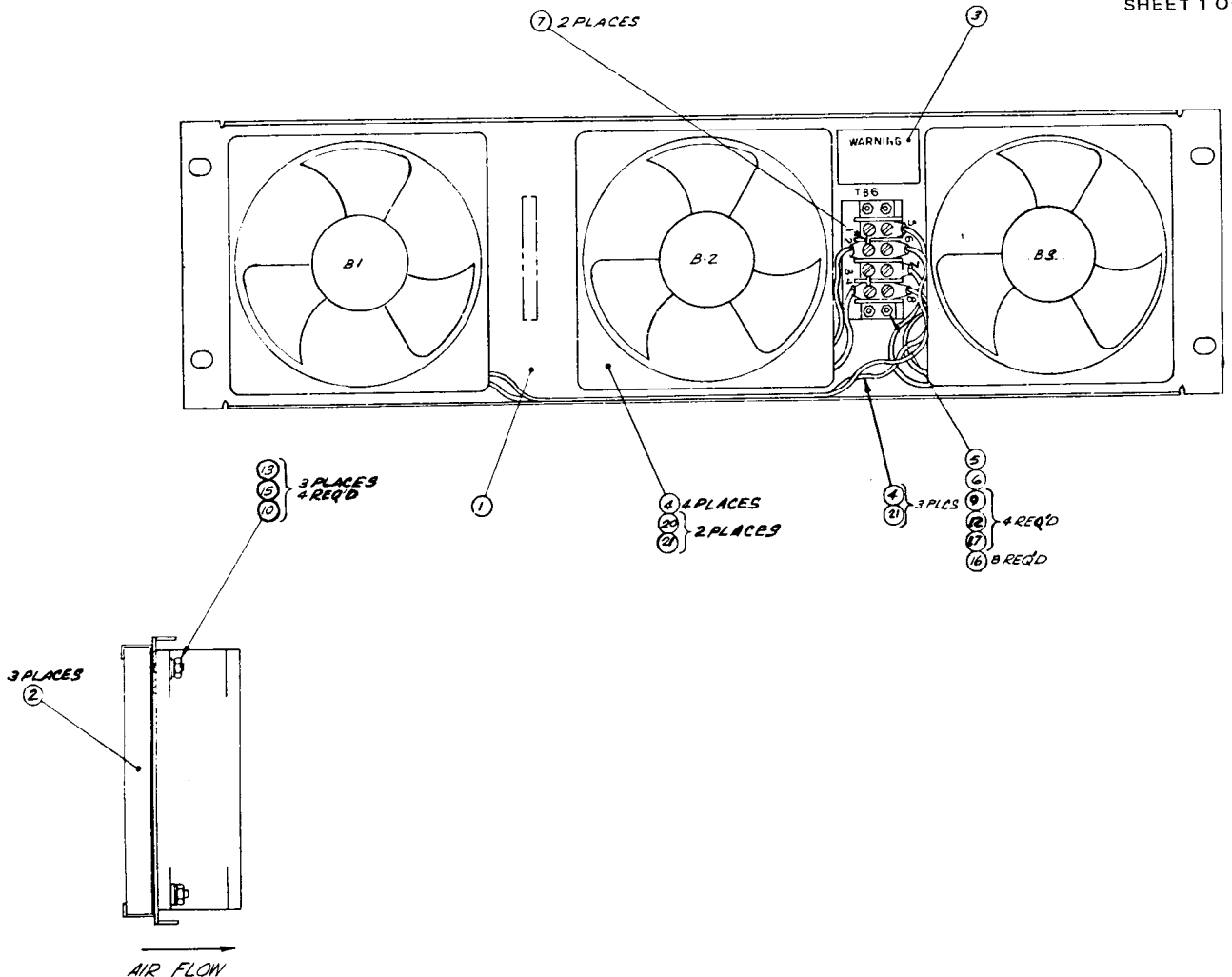

| ITEM NO. | AMPEX PART NO. | REFERENCE NUMBER | DESCRIPTION | JEDEC NO. OR MFR. PART NO. |
|----------|----------------|------------------|-----------------------------------------------------------------|----------------------------|
| | 4050798-01 | | INPUT/OUTPUT CONNECTOR PANEL ASSEMBLY, 8 CHANNEL (NHA 4010240) | |
| | 4050798-02 | | INPUT/OUTPUT CONNECTOR PANEL ASSEMBLY, 16 CHANNEL (NHA 4010240) | |
| | 4050798-03 | | INPUT/OUTPUT CONNECTOR PANEL ASSEMBLY, 24 CHANNEL (NHA 4010240) | |
| 1 | 4290916-02 | | CHASSIS, CONNECTOR, 24 CHANNEL | |
| 2 | 4290919-03 | | CHASSIS, CONNECTOR, 8 CHANNEL | |
| 3 | 4290919-04 | | CHASSIS, CONNECTOR, 16 CHANNEL | |
| 4 | 146-998 | | CONNECTOR, AUDIO RECEPT, 3 SOC | |
| 5 | 147-999 | | CONNECTOR, AUDIO RECEPT, 3 PIN | |
| 6 | 166-199 | | CONTACT, SOC, 20-22 AWG, REF: P3 | |
| 7 | 166-200 | | CONTACT, PIN, 20-22 AWG, REF: P4 | |
| 8 | 167-024 | P3,4 | CONNECTOR, PLUG, 12 CONTACT | BURNDY |
| 9 | 041-006 | | RESISTOR, COMP, 620 OHM, 1/2W, 5% | |
| 10 | 301-365 | | STRAP, CABLE | |
| 11 | 302-335 | | STRAP, CABLE, TIE WRAP | |
| 12 | 471-069 | | SCREW, PAN HD, XREC, 6-32 X 0.375 LG | |
| 13 | 471-328 | | SCREW, FLAT HD, XREC, 4-40 X 0.375 LG | |
| 15 | 496-004 | | NUT, KEP, 4-40 | |
| 16 | 496-005 | | NUT, KEP, 6-32 | |
| 18 | 501-008 | | WASHER, FLAT, NO. 4 | |
| 19 | 501-009 | | WASHER, FLAT, NO. 6 | |
| 20 | 501-188 | | WASHER, PLAIN, NO. 6 | |

C

SHEET 1 OF 1

| ITEM NO. | AMPEX PART NO. | REFERENCE NUMBER | DESCRIPTION | JEDEC NO. OR MFR. PART NO. |
|----------|----------------|------------------|---------------------------------------------------------|----------------------------|
| | 4050687-07 | | REPRODUCE HEAD CABLE ASSEMBLY, 8 CHANNEL (NHA 4010240) | |
| | 4050687-08 | | REPRODUCE HEAD CABLE ASSEMBLY, 16 CHANNEL (NHA 4010240) | |
| | 4050687-09 | | REPRODUCE HEAD CABLE ASSEMBLY, 24 CHANNEL (NHA 4010240) | |
| 3 | 166-854 | | BODY CONNECTOR, RECT, RECP, 18 PIN | |
| 4 | 146-129 | | CONNECTOR, SIGNAL CIRCUIT, RECT, RECP, 20SOC | |
| 6 | 169-080 | | CONTACT, PIN, CONN, 14-16 AWG | |
| 7 | 169-086 | | CONTACT, PIN, CONN, 24 AWG | |
| 8 | 172-003 | | TERMINAL LUG, SOLDER, RING TONGUE, NO. 6 | C |

SHEET 1 OF 1

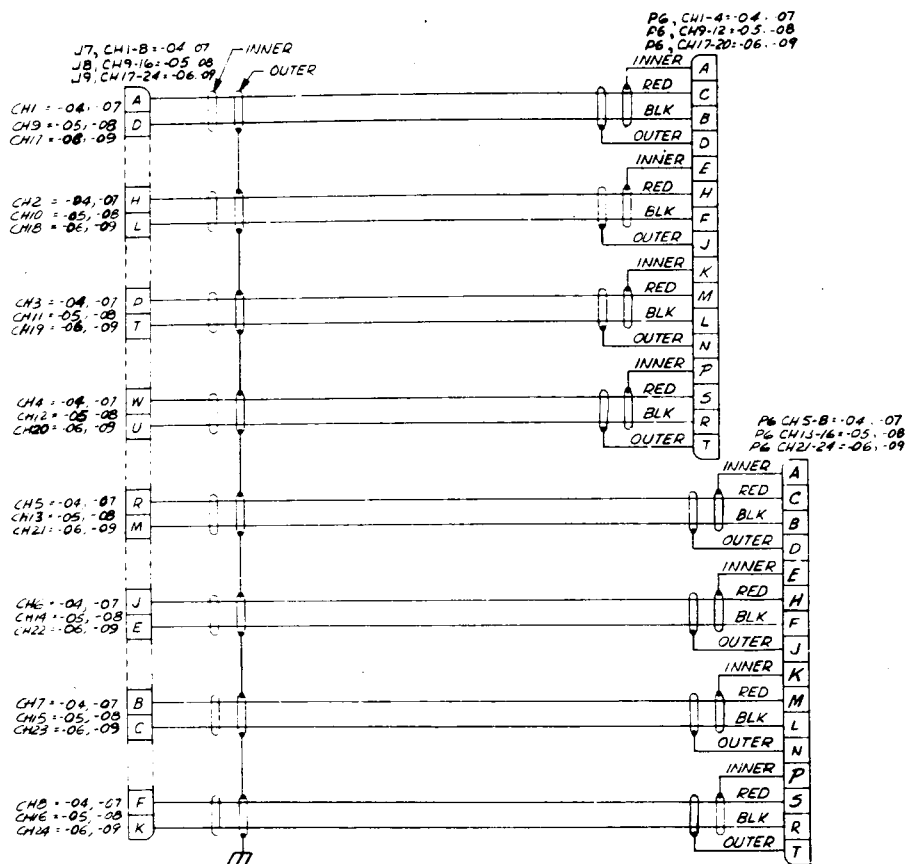

WIRING DIAGRAM

| ITEM NO. | AMPEX PART NO. | REFERENCE NUMBER | DESCRIPTION | JEDEC NO. OR MFR. PART NO. |
|----------|----------------|------------------|------------------------------------------------------|----------------------------|
| | 4050688-04 | | RECORD HEAD CABLE ASSEMBLY, 8 CHANNEL (NHA 4010240) | |
| | 4050688-05 | | RECORD HEAD CABLE ASSEMBLY, 16 CHANNEL (NHA 4010240) | |
| | 4050688-06 | | RECORD HEAD CABLE ASSEMBLY, 24 CHANNEL (NHA 4010240) | |
| 3 | 145-170 | | BODY, CONNECTOR, RECT, PLUG, 20 POS | |
| 4 | 146-129 | | CONNECTOR, SIGNAL CIRCUIT, RECT, RE CP, 20 SOC | |
| 6 | 169-080 | | CONTACT, PIN, CONN, 14-16 AWG | |
| 7 | 169-086 | | CONTACT, PIN, CONN, 24 AWG | |
| 8 | 172-003 | | TERMINAL LUG, SOLDER, RING TONGUE, NO. 6 | A |

SHEET 1 OF 1

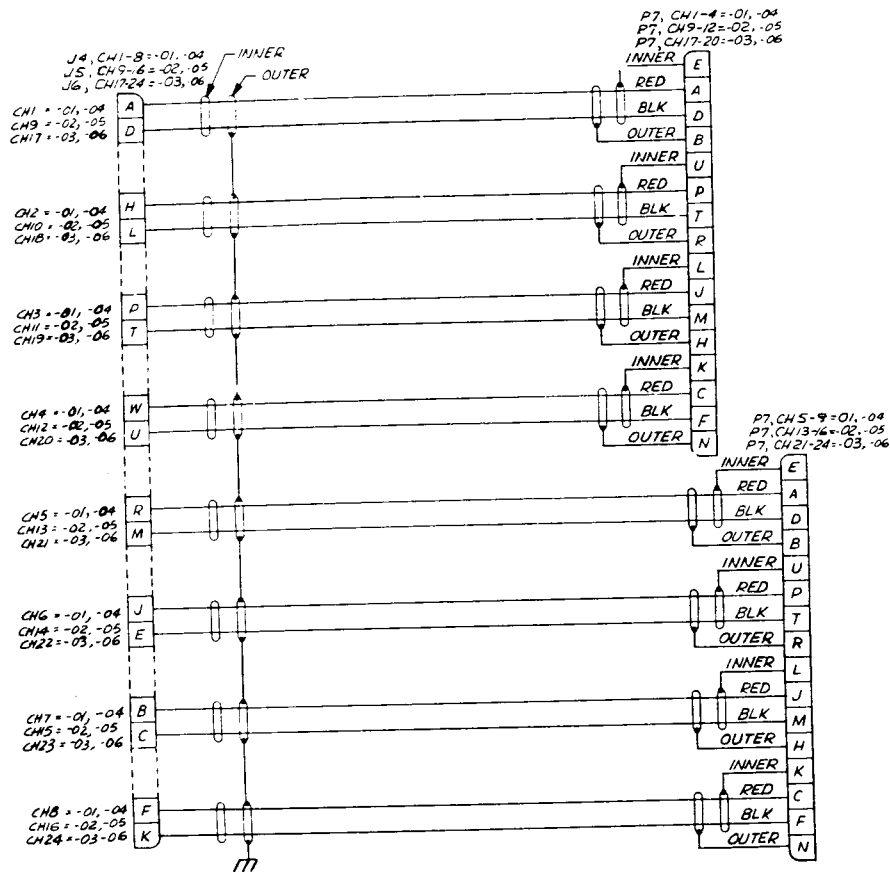

WIRING DIAGRAM

| ITEM NO. | AMPEX PART NO. | REFERENCE NUMBER | DESCRIPTION | JEDEC NO. OR MFR. PART NO. |
|----------|----------------|------------------|------------------------------------------------------------------------|----------------------------|
| | 4050770-01 | | ELECTRONICS POWER AND CONTROL CABLE ASSEMBLY, 8 CHANNEL (NHA 4010240) | |
| | 4050770-02 | | ELECTRONICS POWER AND CONTROL CABLE ASSEMBLY, 16 CHANNEL (NHA 4010240) | |
| | 4050770-03 | | ELECTRONICS POWER AND CONTROL CABLE ASSEMBLY, 24 CHANNEL (NHA 4010240) | |
| 1 | 4840401 | | WIRING DIAGRAM | |
| 3 | 166-199 | | CONTACT, CONN, SOC, 20 AWG, REF: P2A, 2B | |
| 4 | 166-200 | | CONTACT, CONN, PIN, 20 AWG, REF: P8,P9,P10 | |
| 5 | 166-225 | | CONTACT, CONN, SOC, 16 AWG, REF: P2A, 2B | |
| 6 | 166-227 | | CONTACT, CONN, PIN, 16 AWG, REF: P8, P9, P10 | |
| 7 | 167-028 | P8,9,10,P2 | CONNECTOR, RECT, 36 PIN | B |

SHEET 1 OF 1

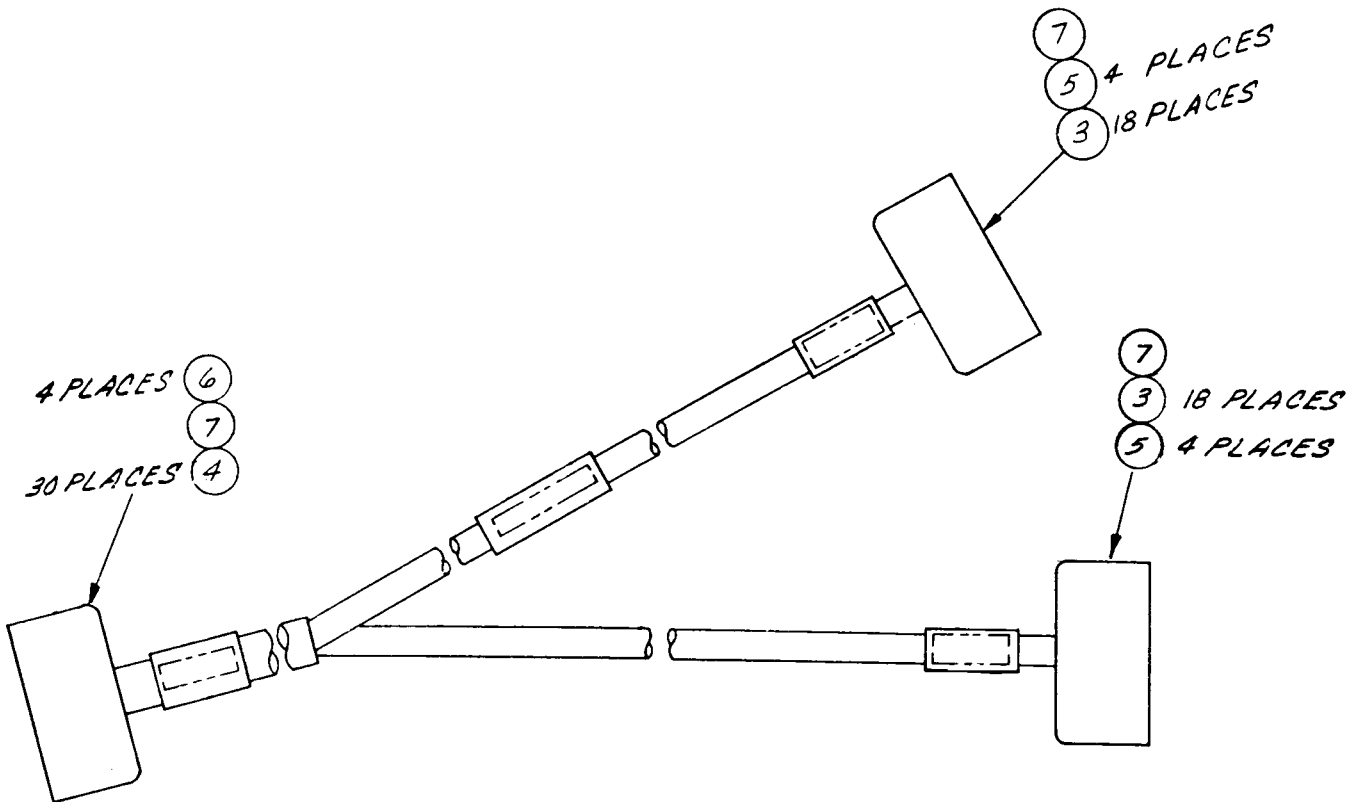



D

D

C

C

B

B

A

P8/P9/PI0

- 10
- 11
- 12
- 13
- 14
- 15
- 16
- 17
- 29
- 30
- 31
- 32
- 8
- 5
- 3
- 2
- 1
- 4
- 6
- 7
- 18
- 19
- 21
- 22
- 23
- 24
- 25
- 26
- 27
- 28
- 33
- 34
- 35
- 36

P2A

- 10 RECORD PULSE CH1
- 11 RECORD PULSE CH2
- 12 RECORD PULSE CH3
- 13 RECORD PULSE CH4
- 14 RECORD HOLD CH1
- 15 RECORD HOLD CH2
- 16 RECORD HOLD CH3
- 17 RECORD HOLD CH4
- 20 MON SEL CH1
- 21 MON SEL CH2
- 22 MON SEL CH3
- 23 MON SEL CH4
- 8 +39VDC
- 5 +39VDC COMMON
- 3 BIAS
- 2 BIAS
- 1 BIAS COMMON
- 4 HI EQUALIZATION
- 6 LO EQUALIZATION
- 7 STBY MON
- 18 +27VDC
- 19 +27VDC COMMON

P2B

- 8 +39VDC
- 5 +39VDC COMMON
- 3 BIAS
- 2 BIAS
- 1 BIAS COMMON
- 4 HI EQUALIZATION
- 6 LO EQUALIZATION
- 7 STBY MON
- 18 +27VDC
- 19 +27VDC COMMON
- 10 RECORD PULSE CH5
- 11 RECORD PULSE CH6
- 12 RECORD PULSE CH7
- 13 RECORD PULSE CH8
- 14 RECORD HOLD CH5
- 15 RECORD HOLD CH6
- 16 RECORD HOLD CH7
- 17 RECORD HOLD CH8
- 20 MON SEL CH5
- 21 MON SEL CH6
- 22 MON SEL CH7
- 23 MON SEL CH8

Wiring Diagram No. 4840401—
 Electronics Power and
 Control Cable Assembly

| ITEM NO. | AMPEX PART NO. | REFERENCE NUMBER | DESCRIPTION | JEDEC NO. OR MFR. PART NO. |
|----------|----------------|------------------|------------------------------------------------------------------------------------------------------|----------------------------|
| | 4050805-01 | | METER PANEL ASSEMBLY, 8 CHANNEL (NHA 4010240) | NO. 385 |
| | 4050805-02 | | METER PANEL ASSEMBLY, 16 CHANNEL (NHA 4010240) | |
| | 4050805-03 | | METER PANEL ASSEMBLY, 24 CHANNEL (NHA 4010240) | |
| 1 | 4050682-06 | | METER PANEL CABLE ASSEMBLY | |
| 2 | 4050682-07 | | METER PANEL CABLE ASSEMBLY, 16, 24 CHANNEL | |
| 3 | 4050682-08 | | METER PANEL CABLE ASSEMBLY, 24 CHANNEL | |
| 8 | 4110293-01 | | OVERLAY, METER PANEL, 24 CHANNEL | |
| 10 | 4110293-03 | | OVERLAY, METER PANEL, 16 CHANNEL | |
| 11 | 4110293-04 | | OVERLAY, METER PANEL, 8 CHANNEL | |
| 13 | 4140024-01 | | METER | |
| 14 | 4150353-01 | | ARM REST ASSY | |
| 17 | 4290816-02 | | PANEL, METER | |
| 19 | 060-530 | | * LAMP, 28V, 40 mA, T- 1-3/4 BULB | |
| 20 | 171-009 | | TERMINAL, QUICK DISCONNECT, SPLICE | |
| 21 | 280-718 | | SPACER, THREADED, NO. 4-40 X 0.31 LG, 8,16 CHANNEL | |
| 23 | 302-335 | | STRAP, CABLE, 0.75 DIAM. | |
| 24 | 302-365 | | STRAP, CABLE, 1.75 DIAM. | |
| 26 | 471-069 | | SCREW, PAN HD, XREC, NO. 6-32 X 0.37 LG | |
| 27 | 471-082 | | SCREW, PAN HD, XREC, No. 8-32 X 0.75 LG | |
| 30 | 496-004 | | NUT, KEP, NO. 4-40 | |
| 31 | 496-005 | | NUT, KEP, NO. 6-32 | |
| 32 | 502-003 | | WASHER, LOCK, NO. 6 | |
| 33 | 501-008 | | WASHER, PLAIN, NO. 4 | |
| 34 | 501-009 | | WASHER, PLAIN, NO. 6 | |
| 35 | 501-010 | | WASHER, PLAIN, NO. 8 | |
| 36 | 502-004 | | WASHER, LOCK, NO. 8 | |
| 37 | 502-027 | | WASHER, LOCK, INT TOOTH, NO. 10 | |
| 46 | 4840414 | | METER PANEL WIRING DIAGRAM | |
| | | | *IF BRIGHTER ILLUMINATION IS DESIRED, USE LAMP NO. 327 (060-019) OR LONG LIFE LAMP NO. 387 (060-391) | |

G

SHEET 1 OF 1

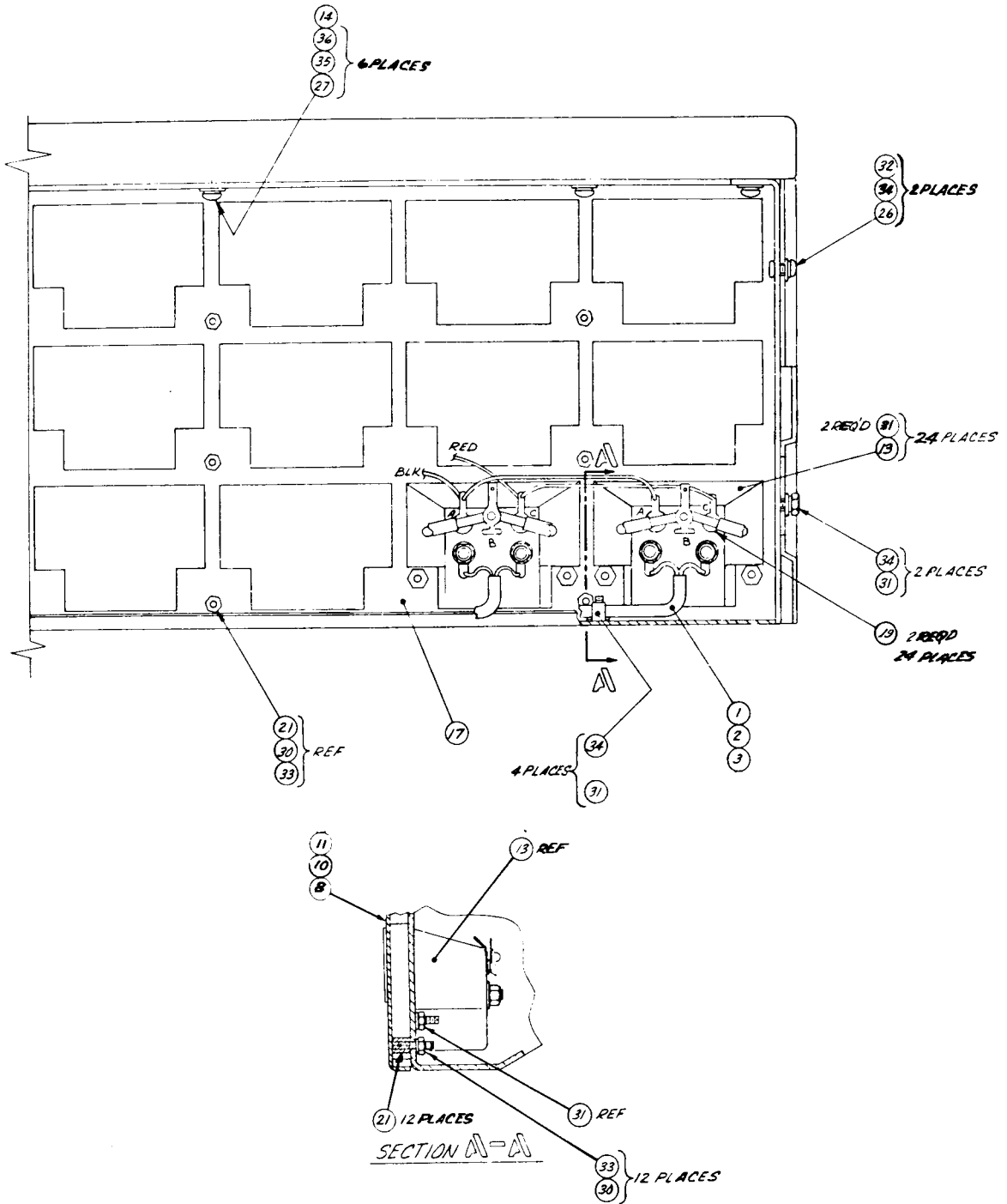

Assembly No. 4050805. Meter Panel Assembly

4

3

2

4840414

DISTR CODE:

1

D

D

C

C

B

B

A

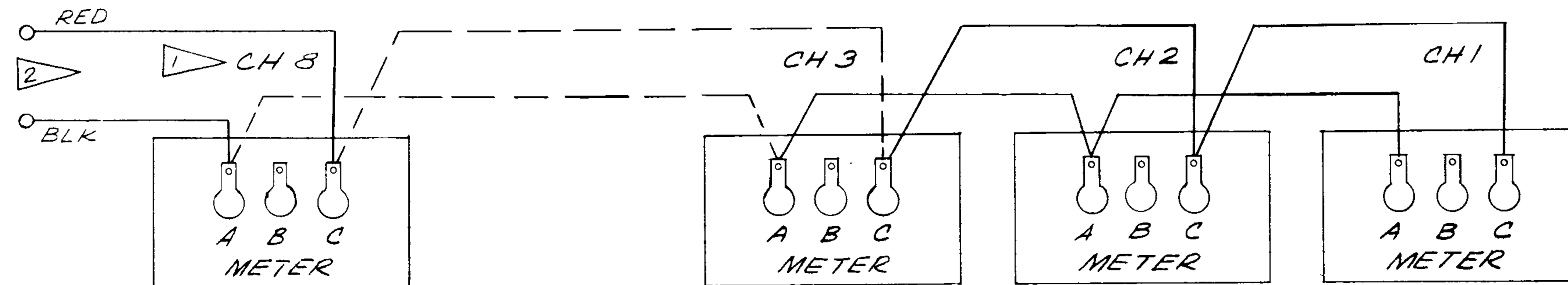

NOTES:

- 1 WIRING SHOWN FOR CHANNELS 1 THRU 8. TYPICAL FOR CHANNELS 9 THRU 16 AND 17 THRU 24.
- 2 QUICK DISCONNECT TERMINALS
- 3 ALL WIRINGS ARE #22 AWG

Wiring Diagram No. 4840414B.
Meter Panel Assembly

| ITEM NO. | AMPEX PART NO. | REFERENCE NUMBER | DESCRIPTION | JEDEC NO. OR MFR. PART NO. |
|----------|----------------|------------------|------------------------------------------------------|----------------------------|
| | 4050682-06 | | METER PANEL CABLE ASSEMBLY, 8 CHANNEL (NHA 4050805) | |
| | 4050682-07 | | METER PANEL CABLE ASSEMBLY, 16 CHANNEL (NHA 4050805) | |
| | 4050682-08 | | METER PANEL CABLE ASSEMBLY, 24 CHANNEL (NHA 4050805) | |
| 2 | 171-009 | | TERMINAL, QUICK DISCONNECT, KNIFE | |
| 3 | 172-005 | | TERMINAL LUG SOLDER, RING TONGUE, NO. 10 | |
| 11 | 167-026 | | BODY CONNECTOR, RECT PLUG, 24 CONTACT | |
| 12 | 166-200 | | CONTACT, PIN, 22-20 AWG | D |

SHEET 1 OF 1

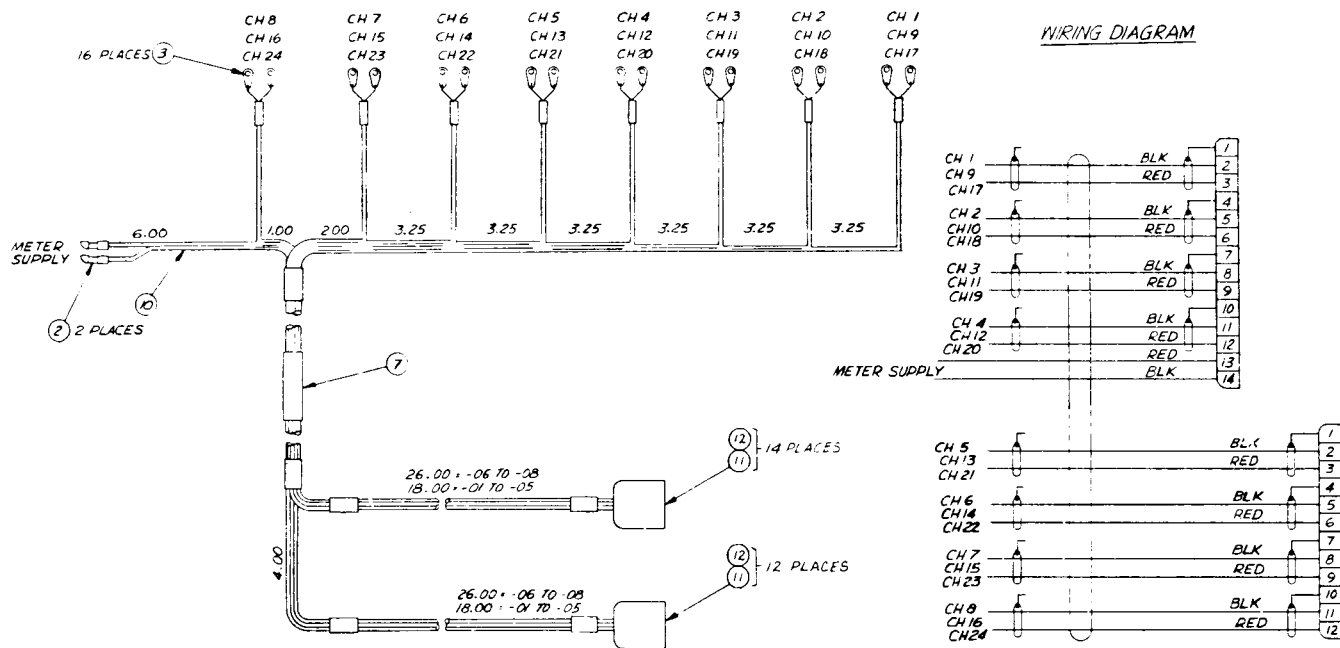

| ITEM NO. | AMPEX PART NO. | REFERENCE NUMBER | DESCRIPTION | JEDEC NO. OR MFR. PART NO. |
|----------|----------------|------------------|-------------------------------------|----------------------------|
| | 4050789-02 | | AC OUTLET ASSEMBLY (NHA 4010239) | |
| 1 | 4260425-01 | | BRACKET, A.C. OUTPUT | |
| 2 | 145-297 | | CONNECTOR, RECT, 3 PIN | |
| 3 | 145-590 | | CONNECTOR, RECP, AC POWER | |
| 4 | 262-002 | | BUSHING | |
| 6 | 4260425-02 | | BRACKET, AC OUTPUT | E |

SHEET 1 OF 1

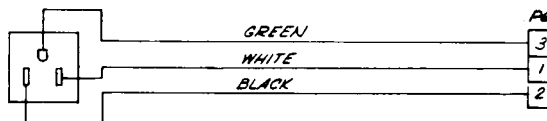
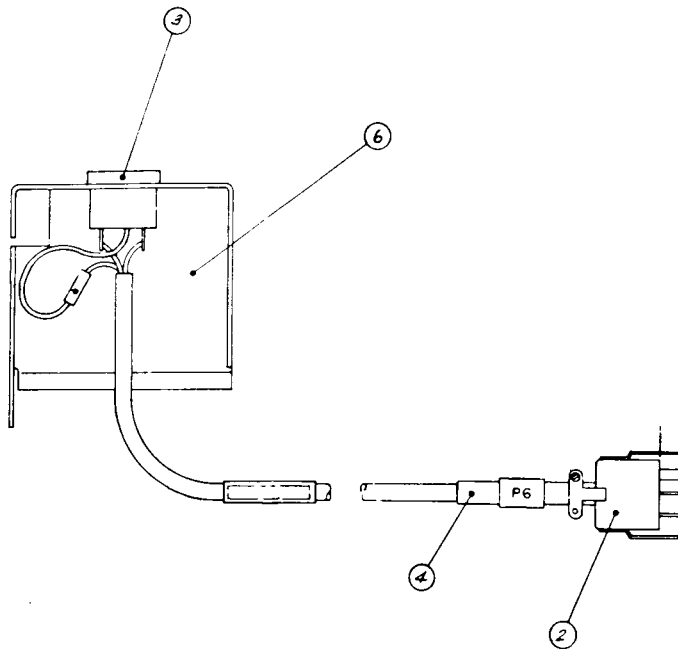

WIRING DIAGRAM

| ITEM NO. | AMPEX PART NO. | REFERENCE NUMBER | DESCRIPTION | JEDEC NO. OR MFR. PART NO. |
|----------|----------------|------------------|---------------------------------------------------|----------------------------|
| | 4010248-01 | | MISCELLANEOUS PARTS KIT, ONE-INCH (NHA 4010240) | |
| | 4010248-02 | | MISCELLANEOUS PARTS KIT, TWO-INCH (NHA 4010240) | |
| 1 | 4050695-04 | | EXTENDER BOARD PWA | |
| 2 | 4030415-01 | | CONTROL BOX ASSY, DUMMY | |
| 8 | 4952254-01 | | RING, HOLDDOWN, 1-INCH | |
| 9 | 4952563-01 | | ADAPTER RING, REEL LOWER, 1-INCH | |
| 10 | 4890400-01 | | MANUAL, OPERATION AND MAINTENANCE, MM-1200 | |
| 14 | 102-031 | | REEL, 1-INCH | |
| 15 | 102-112 | | REEL, 2-INCH | |
| 16 | 310-633 | | CATCH ASSEMBLY | |
| 18 | 041-415 | R51 | RESISTOR, COMP, 68K, 1/4W, 5% | |
| 19 | 057-127 | R54 | RESISTOR, M.F. 20K, 1/4W, 2% | |
| 20 | 057-145 | R49 | RESISTOR, M.F. 110K, 1/4W, 2% | |
| 25 | 718-051 | | BAG, POLYETHYLENE, 16X18, REF: ITEM NO. 10 | |
| 26 | 718-008 | | BAG, POLYETHYLENE, 4X6, REF: ITEM NO.'S 18, 19,20 | |
| 27 | 718-022 | | BAG, "JIFFY", NO, 7, 14 X 20 | |
| 30 | 1206876-03 | | CARTON, ACCESSORY, 21 5/8 X 2 5/8 X 23 1/4 | |

G

| ITEM NO. | AMPEX PART NO. | REFERENCE NUMBER | DESCRIPTION | JEDEC NO. OR MFR. PART NO. |
|----------|----------------|------------------|---------------------------------------|----------------------------|
| | 4050695-04 | | EXTENDER BOARD ASSEMBLY (NHA 4010248) | |
| 2 | 143-804 | | CONNECTOR, PC RECEPT. | |
| 3 | 169-318 | | KEY, POLARIZING | |
| 7 | 471-060 | | SCREW, PAN HD, XREC, 4-40 X 0.25 LG | |
| 8 | 501-008 | | WASHER, PLAIN, NO. 4 | |
| 9 | 502-002 | | WASHER, LOCK, NO. 4 | |
| 10 | 4290886-01 | | HOOK, EXTENDER BOARD | F |

SHEET 1 OF 1

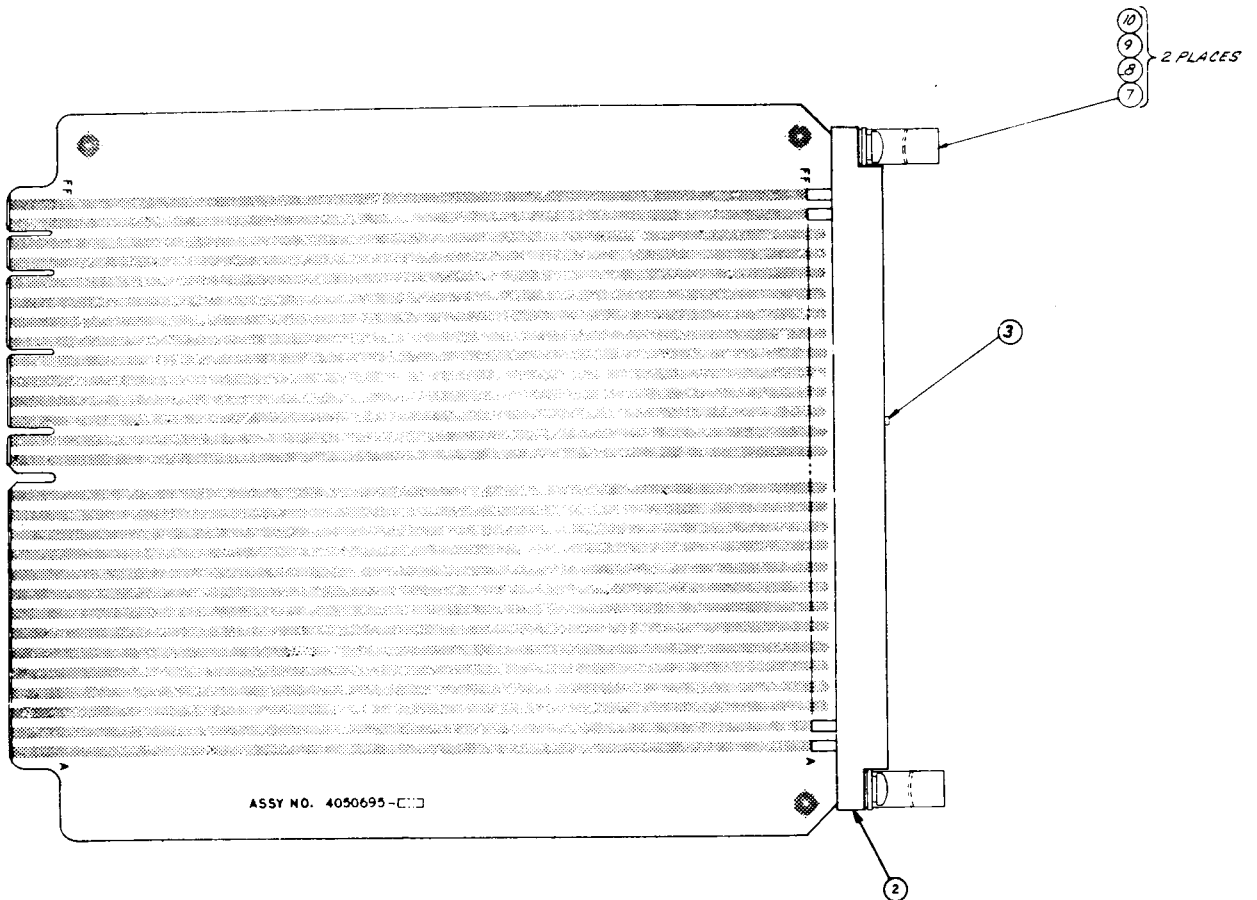

| ITEM NO. | AMPEX PART NO. | REFERENCE NUMBER | DESCRIPTION | JEDEC NO. OR MFR. PART NO. |
|----------|-----------------------|------------------|-------------------------------------------------------------------------------------------------------------------|----------------------------|
| 1 | 4050710-01 145-013 | | REMOTE CONTROL DUMMY PLUG ASSEMBLY, WITH WIRING DIAGRAM (NHA 4010240) CONNECTOR, SIGNAL CIRCUIT, 8 PINS | B |

SHEET 1 OF 1

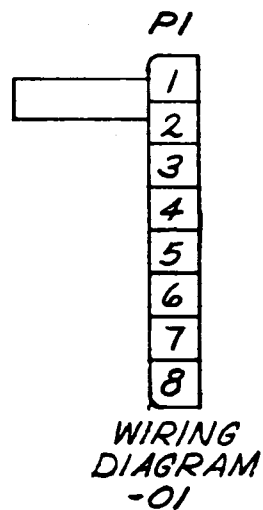
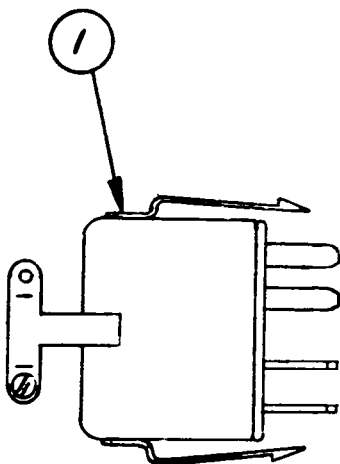

| ITEM NO. | AMPEX PART NO. | REFERENCE NUMBER | DESCRIPTION | JEDEC NO. OR MFR. PART NO. |
|----------|----------------|------------------|---------------------------------------------|----------------------------|
| | 4050857-01 | | REAR TRANSPORT PANEL ASSEMBLY (NHA 4010240) | |
| 1 | 4041276-01 | | PANEL, TRANSPORT, REAR | |
| 2 | 4605002-10 | | CLAMP, CAPACITOR | |
| 3 | 171-009 | | TERMINAL, KNIFE, DISCONNECT | |
| 4 | 171-238 | | TERMINAL, QUICK DISCONNECT | |
| 5 | 302-335 | | STRAP, CABLE, 0.75 DIAM | |
| 6 | 302-365 | | STRAP, CABLE, 1.750 DIAM | |
| 7 | 4840433 | | SCHEMATIC | |
| 9 | 496-006 | | NUT, KEP, 8-32 | |
| 10 | 501-205 | | WASHER, PLAIN, NO. 8 | |
| 12 | 036-157 | C1,2 | CAPACITOR, PAPER, 0.5 UF, 660V. 6% | |
| 13 | 036-158 | C2,3 | CAPACITOR, PAPER, 1.5 UF, 660V, 6% | |
| 15 | 4170343-01 | | LABEL, TRANSPORT PANEL, REAR | |
| 16 | 032-084 | | BOOT, CAPACITOR, REF: C1,C4 | B |

SHEET 1 OF 1

TO BE SELECTED BY FACTORY

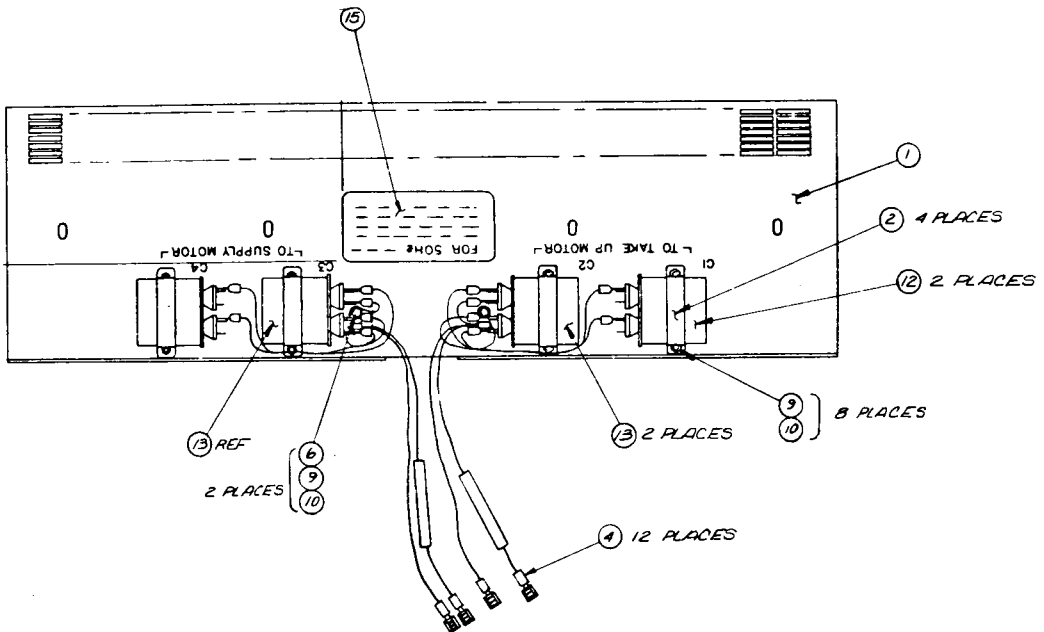

| ITEM NO. | AMPEX PART NO. | REFERENCE NUMBER | DESCRIPTION | JEDEC NO. OR MFR. PART NO. |
|----------|----------------|------------------|------------------------------------------------------------|----------------------------|
| | 4010239-03 | | MM-1200 ACCESSORIES (NHA 4010240) | |
| 1A | 4010246-01 | | CONVERSION KIT, 8 TO 16 CHANNEL, NAB 15-30 IN/S | |
| 1B | 4010246-02 | | CONVERSION KIT, 8 TO 16 CHANNEL, NAB, 7.5-15 IN/S | |
| 1C | 4010246-03 | | CONVERSION KIT, 8 TO 16 CHANNEL, CCIR/IEC, 15-30 IN/S | |
| 1D | 4010246-04 | | CONVERSION KIT, 8 TO 16 CHANNEL, CCIR/IEC, 7.5-15 IN/S | |
| 2A | 4010247-01 | | CONVERSION KIT, 16 TO 24 CHANNEL, NAB, 15-30 IN/S | |
| 2B | 4010247-02 | | CONVERSION KIT, 16 TO 24 CHANNEL, NAB, 7.5-15 IN/S | |
| 2C | 4010247-03 | | CONVERSION KIT, 16 TO 24 CHANNEL, CCIR/IEC, 15-30 IN/S | |
| 2D | 4010247-04 | | CONVERSION KIT, 16 TO 24 CHANNEL, CCIR/IEC, 7.5-15 IN/S | |
| 3 | 4010244-01 | | OVERHEAD BRIDGE, 3-1/2 IN RISER KIT | |
| 4 | 4020151-04 | | REPRODUCE EXTENDER BOARD ASSEMBLY | |
| 5 | 4020152-02 | | RECORD EXTENDER BOARD ASSEMBLY | |
| 6 | 4020153-04 | | BIAS AMPLIFIER EXTENDER BOARD ASSEMBLY | |
| 7 | 4020154-02 | | POWER SUPPLY EXTENDER BOARD ASSEMBLY | |
| 8 | 4050789-02 | | AC OUTLET ASSEMBLY | |
| 9 | 4020334-03 | | ONE INCH HEAD ASSEMBLY, 8 CHANNEL | |
| 10 | 4020372-05 | | TWO INCH HEAD ASSEMBLY, 16 CHANNEL | |
| 11 | 4020410-02 | | REMOTE DISPLAY ASSEMBLY, SEARCH-TO-CUE AND TIMER | |
| 12 | 4020411-02 | | CONTROL BOX ASSEMBLY, TRANSPORT ONLY | |
| 13 | 4010249-01 | | TAPE SPLICER | |
| 14 | 4010242-02 | | OVERHEAD BRIDGE ASSEMBLY | |
| 15 | 4050801-01 | | MOTOR DRIVE AMPLIFIER EXTENDER BOARD PWA | |
| 16 | 4050803-01 | | SWITCHER EXTENDER PWA | |
| 17 | 4210353-01 | | GUIDE, 1 INCH, FIXED | |
| 18 | 4210353-02 | | GUIDE, 2 INCH, FIXED | |
| 21 | 4850154-02 | | CONVERSION KIT, 2 INCH TO 1 INCH | |
| 24 | 4952348-02 | | REMOTE INTERCONNECT CABLE ASSEMBLY | |
| 25 | 4030414-01 | | BRUSH ASSEMBLY REPLACEMENT KIT AND PROCEDURE | |

K

SHEET 1 OF 1

| ITEM NO. | AMPEX PART NO. | REFERENCE NUMBER | DESCRIPTION | JEDEC NO. OR MFR. PART NO. |
|----------|----------------|------------------|----------------------------------------------------------------------|----------------------------|
| | 4010246-01 | | CONVERSION KIT, 8 TO 16 CHANNEL, NAB, 15-30 IN/S (NHA 4010239) | |
| | 4010246-02 | | CONVERSION KIT, 8 TO 16 CHANNEL, NAB, 7.5-15 IN/S (NHA 4010239) | |
| | 4010246-03 | | CONVERSION KIT, 8 TO 16 CHANNEL, CCIR/IEC, 15-30 IN/S (NHA 4010239) | |
| | 4010246-04 | | CONVERSION KIT, 8 TO 16 CHANNEL, CCIR/IEC, 7.5-15 IN/S (NHA 4010239) | |
| 1 | 4020269-06 | | RECORD EQUALIZER PWA, CCIR/IEC | |
| 2 | 4020269-08 | | RECORD EQUALIZER PWA, NAB | |
| 3 | 4020270-02 | | REPRODUCE EQUALIZER PWA | |
| 4 | 4020372-05 | | TWO-INCH HEAD ASSEMBLY, 16 CHANNEL, 15-30 IN/S | |
| 5 | 4020372-07 | | TWO-INCH HEAD ASSEMBLY, 16 CHANNEL, 7.5-15 IN/S | |
| 7 | 4840414 | | SCHEMATIC | |
| 8 | 4020394-05 | | CONTROL BOX ASSEMBLY, 16 CHANNEL | |
| 9 | 4020402-01 | | ELECTRONICS ASSEMBLY, 15-30 IN/S | |
| 10 | 4010265-01 | | TWO-INCH ROTARY GUIDE ASSEMBLY KIT | |
| 12 | 4020402-02 | | ELECTRONICS ASSEMBLY, 7.5-15 IN/S | |
| 13 | 4050682-07 | | METER PANEL CABLE ASSEMBLY | |
| 14 | 4050686-05 | | ERASE HEAD CABLE ASSEMBLY | |
| 15 | 4050687-08 | | REPRODUCE HEAD CABLE ASSEMBLY | |
| 16 | 4050688-05 | | RECORD HEAD CABLE ASSEMBLY | |
| 18 | 171-009 | | TERMINAL, QUICK DISCONNECT, SPLICE | |
| 19 | 4050770-02 | | ELECTRONICS POWER AND CONTROL CABLE ASSEMBLY | |
| 20 | 4050798-02 | | INPUT/OUTPUT CONNECTOR PANEL ASSEMBLY | |
| 22 | 496-005 | | NUT, KEP, 6-32 | |
| 23 | 4100079-09 | | BUTTON, ELEC, CH 9 | |
| 24 | 4100079-10 | | BUTTON, ELEC, CH 10 | |
| 25 | 4100079-11 | | BUTTON, ELEC, CH 11 | |
| 26 | 4100079-12 | | BUTTON, ELEC, CH 12 | |
| 27 | 4100079-13 | | BUTTON, ELEC, CH 13 | |
| 28 | 4100079-14 | | BUTTON, ELEC, CH 14 | |
| 29 | 4100079-15 | | BUTTON, ELEC, CH 15 | |
| 30 | 4100079-16 | | BUTTON, ELEC, CH 16 | |
| 31 | 4110293-03 | | OVERLAY, METER PANEL | |
| 32 | 4140024-01 | | METER, VU | |
| 34 | 102-112 | | REEL, 2 IN | |
| 36 | 472-578 | | SCREW, OVAL HD, XREC, 10-32 LG | |
| 37 | 501-702 | | WASHER, FINISHING, NYLON, BLK, NO. 10 | |

C

SHEET 1 OF 1

| ITEM NO. | AMPEX PART NO. | REFERENCE NUMBER | DESCRIPTION | JEDEC NO. OR MFR. PART NO. |
|----------|----------------|------------------|-----------------------------------------------------------------------|----------------------------|
| | 4010247-01 | | CONVERSION KIT, 16 TO 24 CHANNEL, NAB, 15-30 IN/S (NHA 4010239) | |
| | 4010247-02 | | CONVERSION KIT, 16 TO 24 CHANNEL, NAB, 7.5-15 IN/S (NHA 4010239) | |
| | 4010247-03 | | CONVERSION KIT, 16 TO 24 CHANNEL, CCIR/IEC, 15-30 IN/S (NHA 4010239) | |
| | 4010247-04 | | CONVERSION KIT, 16 TO 24 CHANNEL, CCIR/IEC, 7.5-15 IN/S (NHA 4010239) | |
| 1 | 4020269-06 | | RECORD EQUALIZER PWA, CCIR | |
| 2 | 4020269-08 | | RECORD EQUALIZER PWA, NAB | |
| 3 | 4020270-02 | | REPRODUCE EQUALIZER PWA | |
| 4 | 4020372-06 | | TWO-INCH HEAD ASSEMBLY, 24 CHANNEL, 15-30 IN/S | |
| 5 | 4020372-08 | | TWO-INCH HEAD ASSEMBLY, 24 CHANNEL, 7.5-15 IN/S | |
| 6 | 4020394-03 | | CONTROL BOX ASSEMBLY, 24 CHANNEL | |
| 8 | 4020402-01 | | ELECTRONICS ASSEMBLY, 15-30 IN/S | |
| 10 | 4020402-02 | | ELECTRONICS ASSEMBLY, 7.5-15 IN/S | |
| 11 | 4050682-08 | | METER PANEL CABLE ASSEMBLY | |
| 12 | 4050686-06 | | ERASE HEAD CABLE ASSEMBLY | |
| 13 | 4050687-09 | | REPRODUCE HEAD CABLE ASSEMBLY | |
| 14 | 4050688-06 | | RECORD HEAD, CABLE ASSEMBLY | |
| 16 | 4840414 | | SCHEMATIC | |
| 17 | 4050770-03 | | ELECTRONICS POWER AND CONTROL CABLE ASSEMBLY | |
| 18 | 4050798-03 | | INPUT/OUTPUT CONNECTOR PANEL ASSEMBLY, 1-24 CHANNEL | |
| 20 | 171-009 | | TERMINAL, QUICK DISCONNECT, SPLICE | |
| 21 | 4100079-17 | | BUTTON, ELEC, CH 17 | |
| 22 | 4100079-18 | | BUTTON, ELEC, CH 18 | |
| 23 | 4100079-19 | | BUTTON, ELEC, CH 19 | |
| 24 | 4100079-20 | | BUTTON, ELEC, CH 20 | |
| 25 | 4100079-21 | | BUTTON, ELEC, CH 21 | |
| 26 | 4100079-22 | | BUTTON, ELEC, CH 22 | |
| 27 | 4100079-23 | | BUTTON, ELEC, CH 23 | |
| 28 | 4100079-24 | | BUTTON, ELEC, CH 24 | |
| 29 | 4110293-01 | | OVERLAY, METER PANEL | |
| 30 | 4140024-01 | | METER, VU | |
| 31 | 060-530 | | LAMP, INCANDESCENT, 28V, 40MA, T-1-3/4 BULB NO. 385 | NO. 385 |
| 33 | 496-005 | | NUT, KEP, 6-32 | |
| 34 | 472-578 | | SCREW, OVAL HD, XREC, 10-32 X 0.75 LG | |
| 36 | 501-702 | | WASHER, FINISHING, NYLON, BLK, NO. 10 | |

A

SHEET 1 OF 1

| ITEM NO. | AMPEX PART NO. | REFERENCE NUMBER | DESCRIPTION | JEDEC NO. OR MFR. PART NO. |
|----------|----------------|------------------|--------------------------------------------------------|----------------------------|
| | 4020151-04 | | REPRODUCE MODULE EXTENDER BOARD ASSEMBLY (NHA 4010239) | |
| 1 | 4030274-01 | | CONNECTOR, 12 CONTACT | |
| 3 | 471-065 | | SCREW, PAN HD, XREC, NO. 4 X 5/8 LG | |
| 4 | 496-004 | | NUT, KEP, NO. 4 | |
| 5 | 501-008 | | WASHER, FLAT, NO. 4 | |
| 7 | 501-186 | | WASHER, PLAIN, NO. 4 | |
| 8 | 473-284 | | SCREW, PAN HD, XREC, NO. 4-40 X 0.250 LG | |
| 9 | 4041198-01 | | HANDLE ASSY, EXTENDER BOARD | E |

SHEET 1 OF 1

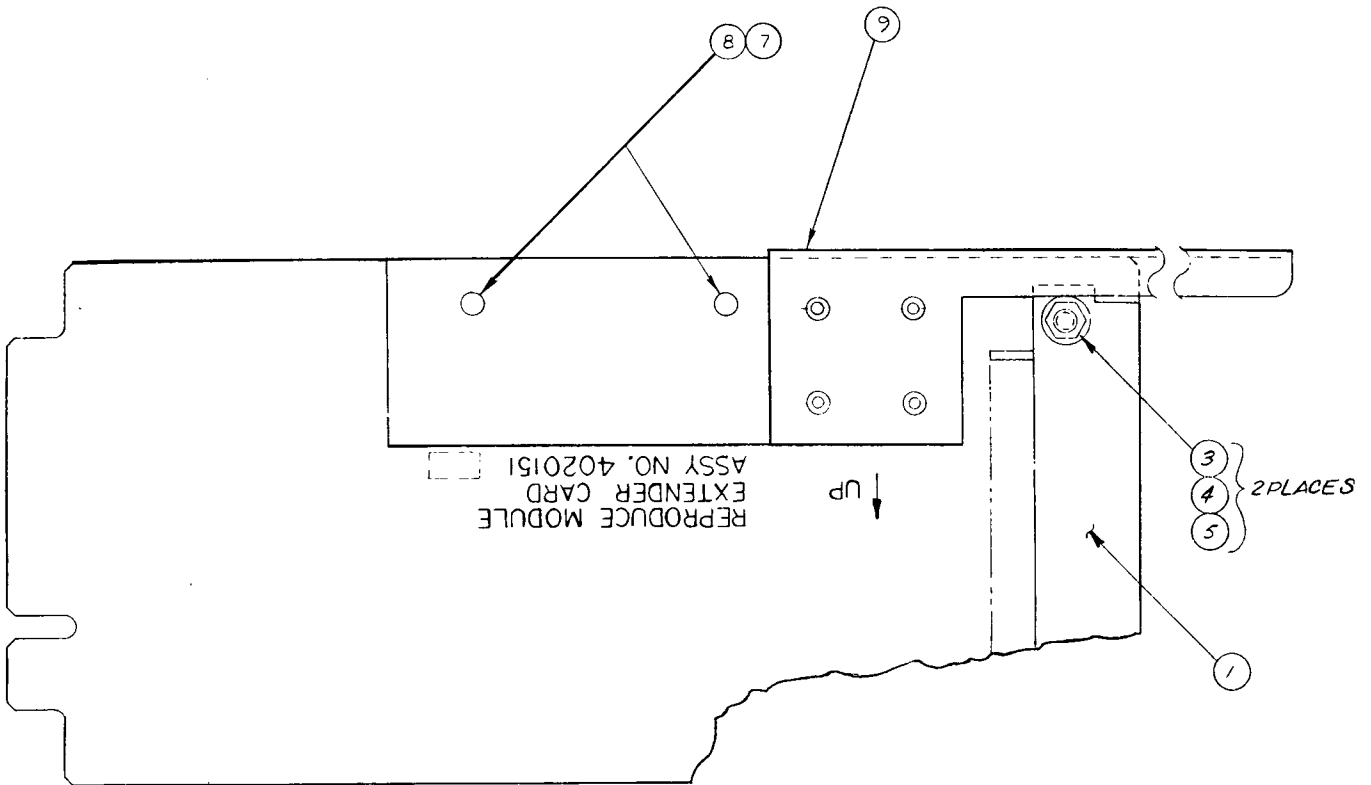

| ITEM NO. | AMPEX PART NO. | REFERENCE NUMBER | DESCRIPTION | JEDEC NO. OR MFR. PART NO. |
|----------|----------------|------------------|-----------------------------------------------------|----------------------------|
| | 4020152-02 | | RECORD MODULE EXTENDER BOARD ASSEMBLY (NHA 4010239) | |
| 1 | 4030274-03 | | CONNECTOR, 12 CONTACT | |
| 3 | 471-471 | | SCREW, PAN HD, XREC, No. 4 X 0.75 LG | |
| 4 | 496-004 | | NUT, KEP, NO. 4 | |
| 5 | 501-008 | | WASHER, FLAT, NO. 4 | |
| 6 | 501-186 | | WASHER, PLAIN, NO. 4 | |
| 7 | 473-284 | | SCREW, PAN HD, XREC, NO. 4-40 X 0.250 LG | |
| 8 | 4041198-01 | | HANDLE ASSY, EXTENDER BOARD | C |

SHEET 1 OF 1

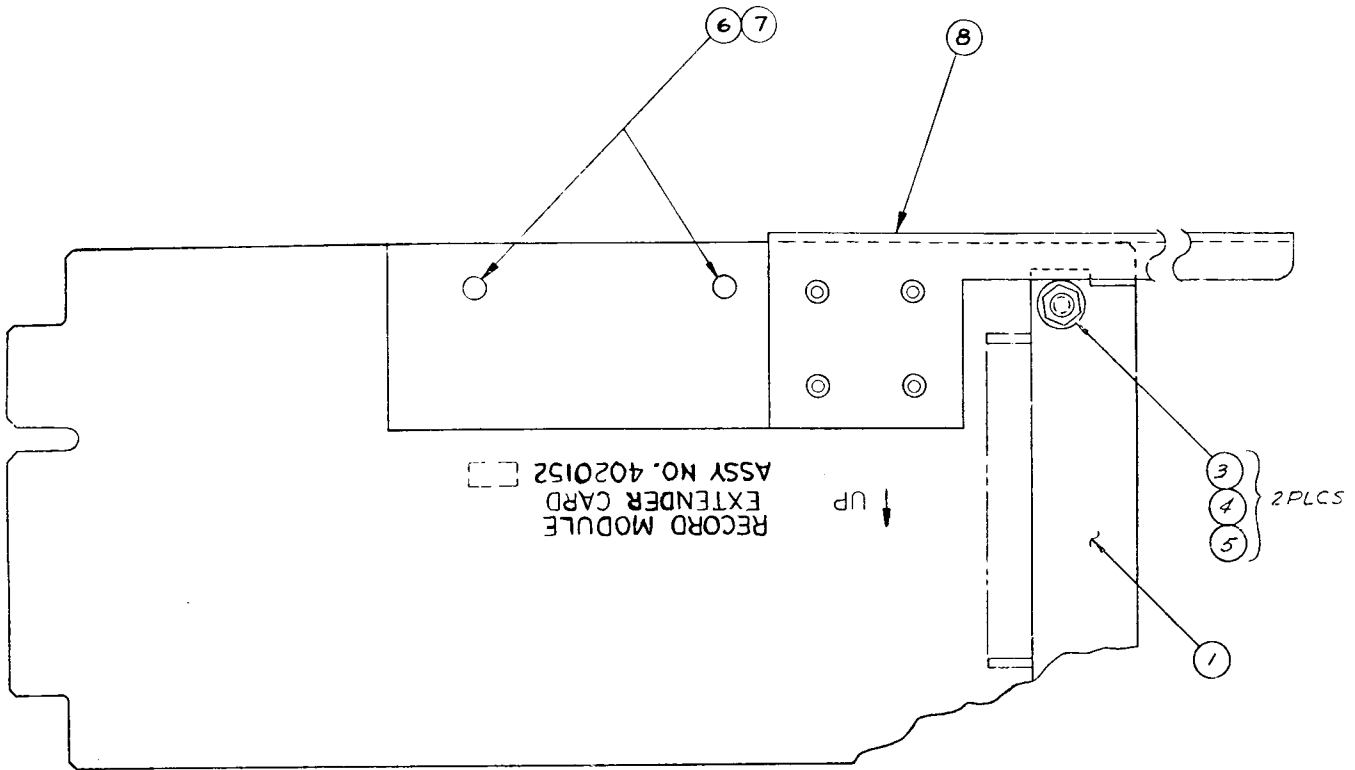

| ITEM NO. | AMPEX PART NO. | REFERENCE NUMBER | DESCRIPTION | JEDEC NO. OR MFR. PART NO. |
|----------|----------------|------------------|------------------------------------------------------|----------------------------|
| | 4020153-04 | | BIAS AMPLIFIER EXTENDER BOARD ASSEMBLY (NHA 4010239) | |
| 1 | 4030274-02 | | CONNECTOR, 12 CONTACT | |
| 2 | 501-186 | | WASHER, PLAIN, NO. 4 | |
| 3 | 471-065 | | SCREW, PAN HD, XREC, NO. 4 X 5/8 LG | |
| 4 | 496-004 | | NUT, KEP, NO. 4 | |
| 5 | 501-008 | | WASHER, FLAT, NO 4 | |
| 7 | 473-284 | | SCREW, PAN HD, XREC, 4-40 X 0.250 LG | |
| 8 | 4041198-01 | | HANDLE ASSY, EXTENDER BOARD | D |

SHEET 1 OF 1

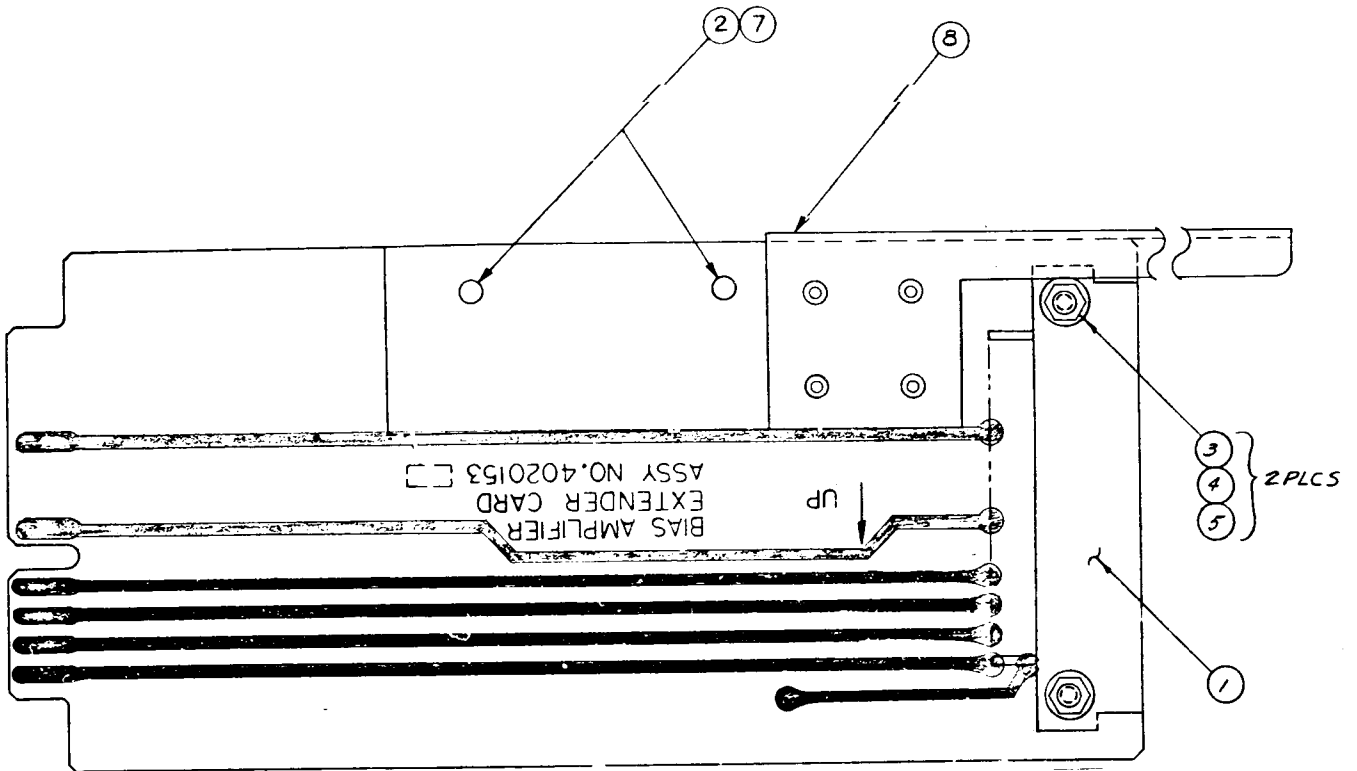

| ITEM NO. | AMPEX PART NO. | REFERENCE NUMBER | DESCRIPTION | JEDEC NO. OR MFR. PART NO. |
|------------------|------------------------------------------------------------|------------------|-------------------------------------------------------------------------------------------------------------------------------------------------------------------|----------------------------|
| 1 3 4 5 | 4020154-02 143-450 471-471 496-004 501-008 | | POWER SUPPLY EXTENDER BOARD ASSEMBLY (NHA 4010239) CONNECTOR, 18 CONTACT SCREW, PAN HD, XREC, NO. 4 X 0.75 LG NUT, KEP, NO. 4 WASHER, FLAT, NO. 4 | C |

SHEET 1 OF 1

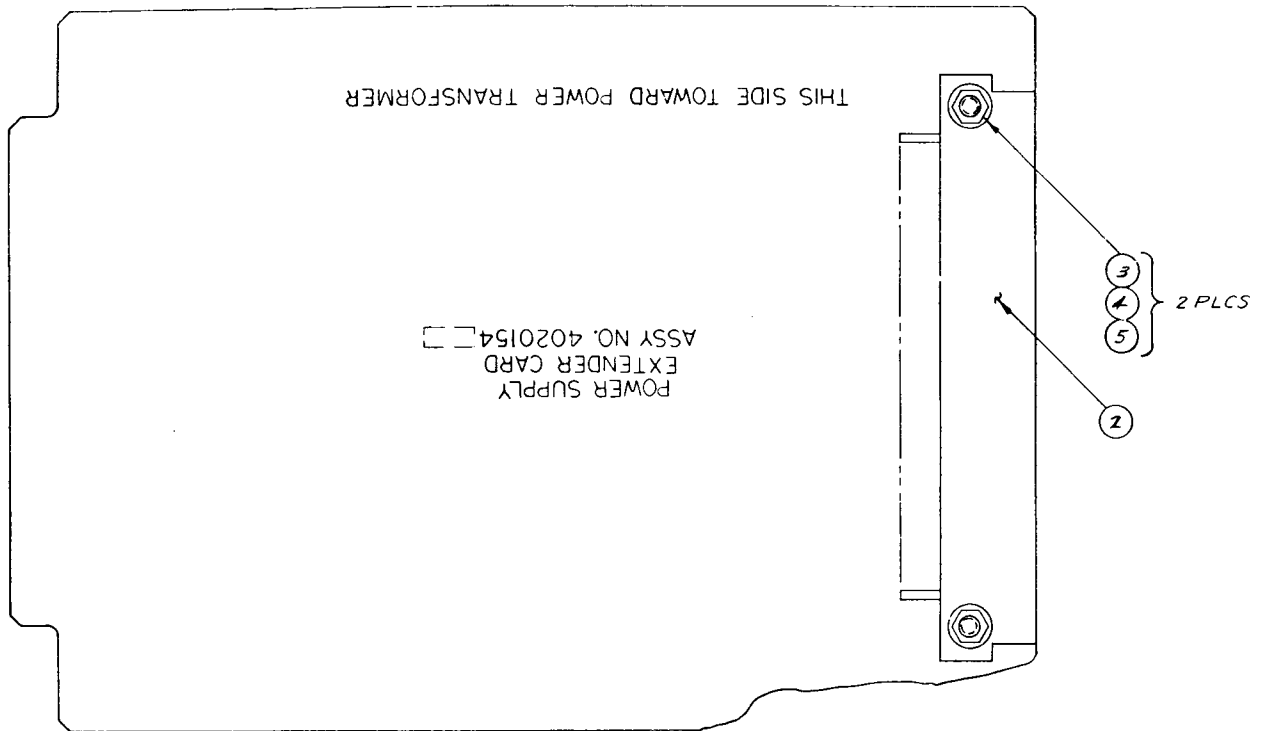

| ITEM NO. | AMPEX PART NO. | REFERENCE NUMBER | DESCRIPTION | JEDEC NO. OR MFR. PART NO. |
|----------|----------------|------------------|---------------------------------------------------------------|----------------------------|
| | 4020410-02 | | SEARCH-TO-CUE AND TIMER REMOTE DISPLAY ASSEMBLY (NHA 4010239) | |
| 3 | 4050810-03 | | SEARCH-TO-CUE/TIMER DISPLAY PWA | |
| 4 | 4110290-02 | | BEZEL, TAPE TIMER | |
| 5 | 4130063-01 | | PAD, SEARCH-TO-CUE/TIMER, REMOTE | |
| 6 | 4170328-01 | | INSULATOR, PWA | |
| 7 | 4290833-03 | | HOUSING | |
| 8 | 4290837-01 | | COVER, BOTTOM | |
| 9 | 4050809-03 | | SEARCH-TO-CUE/TIMER DISPLAY DRIVER PWA | |
| 11 | 6000051-05 | | PLATE | |
| 13 | 119-366 | | SWITCH, PUSHBUTTON | |
| 15 | 280-362 | | SPACER, PLAIN, NO. 4, 0.25 O.D. X 0.125 LG | |
| 16 | 262-003 | | BUSHING, GREEN | |
| 17 | 265-080 | | BUSHING, BLACK | |
| 18 | 471-064 | | SCREW, PAN HD, XREC, 4-40 X 0.50 LG | |
| 20 | 472-465 | | SCREW, FLAT HD, 2-56 X 0.25 LG | |
| 21 | 498-568 | | NUT, DRESS, 1/4 - 40 NS | |
| 22 | 501-863 | | WASHER, SHIM, 0.250 I.D. X 0.374 O.D. X 0.032 THK | |
| 23 | 501-169 | | WASHER, PLAIN, NO. 4 | |
| 24 | 502-002 | | WASHER, LOCK, NO. 4 | |
| 25 | 502-028 | | WASHER, INT TOOTH, NO. 1/4 | |
| 26 | 166-200 | | CONTACT PIN, 22-20 SWG | |
| 28 | 166-902 | | HOUSING, CONNECTOR | |
| 35 | 4840424 | | SCHEMATIC | |

F

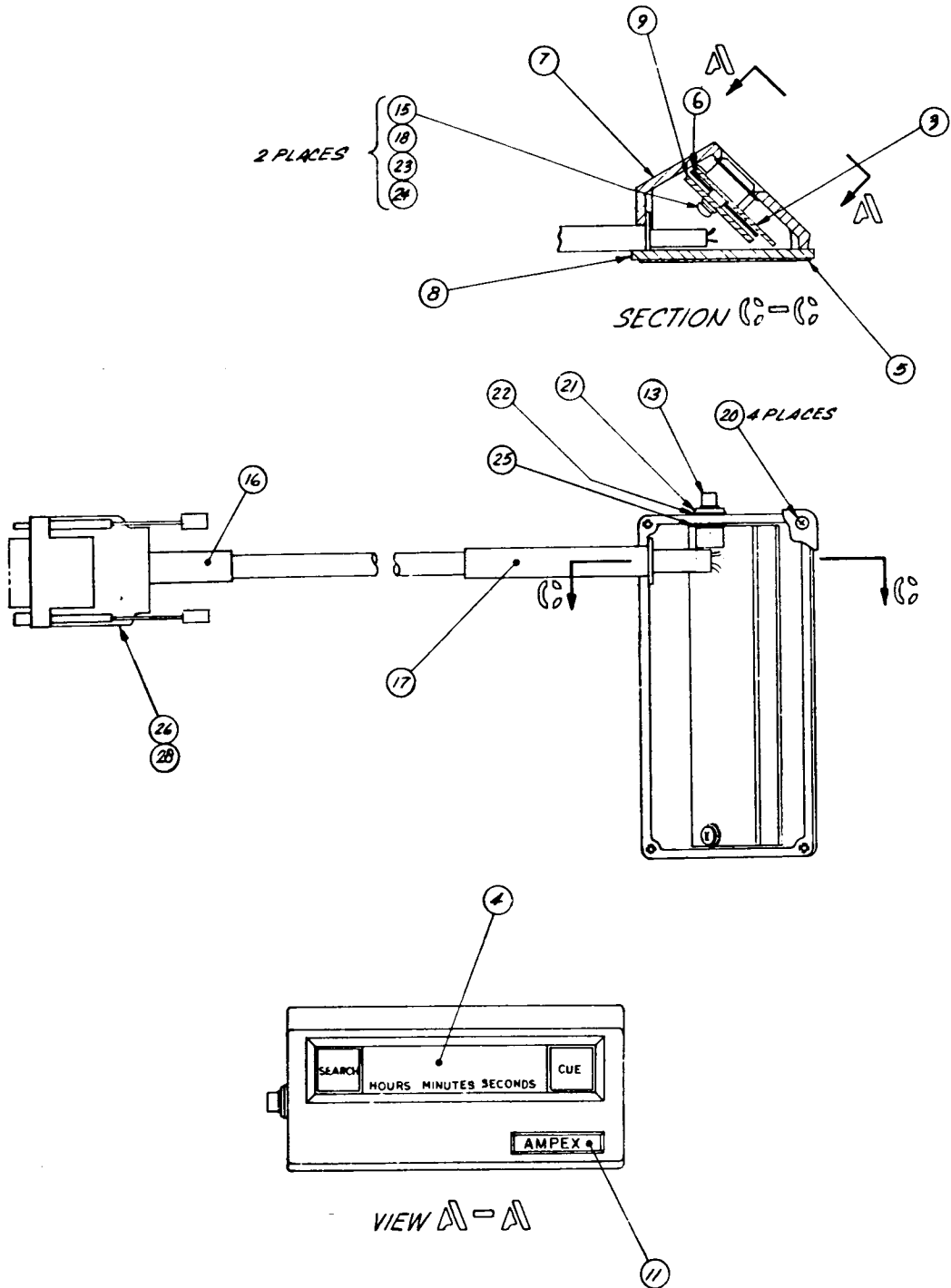

Assembly No. 4020410. Search-To-Cue and Timer Remote Display Assembly

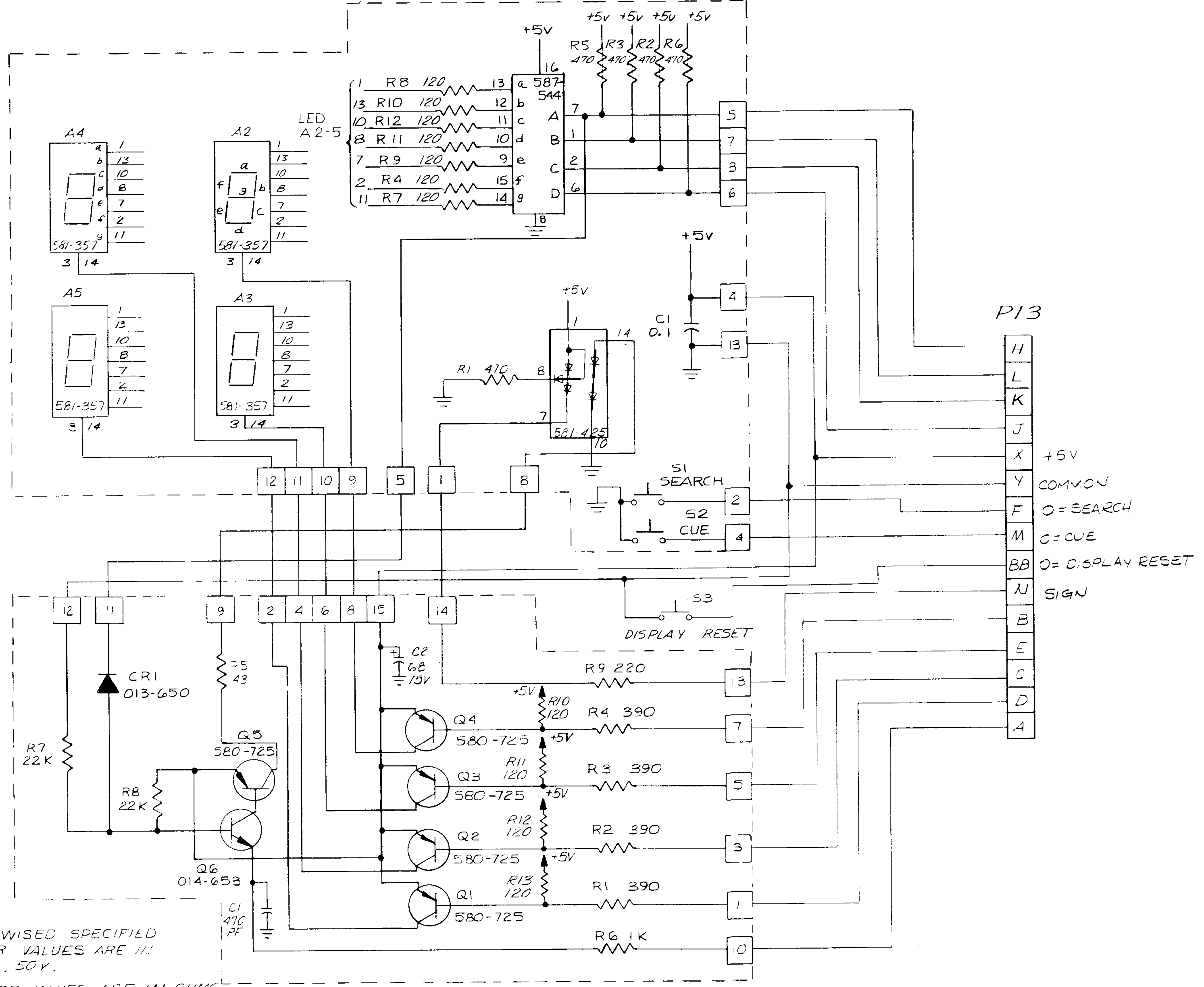

NOTES:
 UNLESS OTHERWISE SPECIFIED
 1. ALL CAPACITOR VALUES ARE IN MICROFARADS, 50V.
 2. ALL RESISTOR VALUES ARE IN OHMS 1/4 WATTS 10%.
 3. P.W.A. NOS ARE 2050309-03 AW REV D
 2050810-03 AW REV A

Schematic No. 4840424A.
 Search-to-Cue and Timer
 Remote Display Assembly

| ITEM NO. | AMPEX PART NO. | REFERENCE NUMBER | DESCRIPTION | JEDEC NO. OR MFR. PART NO. |
|----------|----------------|------------------|-----------------------------------------------------|----------------------------|
| | 4050801-01 | | MOTOR DRIVE AMPLIFIER EXTENDER PWA (NHA 4010239) | |
| 2 | 4630055-01 | | CONNECTOR, MODIFIED | |
| 4 | 290-009 | | BRACKET, ANGLE, 90° | |
| 5 | 530-359 | | GUIDE, P.C. BOARD | |
| 6 | 168-091 | | KEY, POLARIZING | |
| 8 | 471-061 | | SCREW, PAN HD, XREC, 4-40 X 5/16 LG | |
| 9 | 471-064 | | SCREW, PAN HD, XREC, 4-40 X 1/2 LG | |
| 11 | 496-004 | | NUT, KEP, 4-40 | |
| 13 | 501-008 | | WASHER, PLAIN, NO. 4 | |
| 15 | 502-030 | | WASHER, INT. TOOTH, NO. 4 | A |

SHEET 1 OF 1

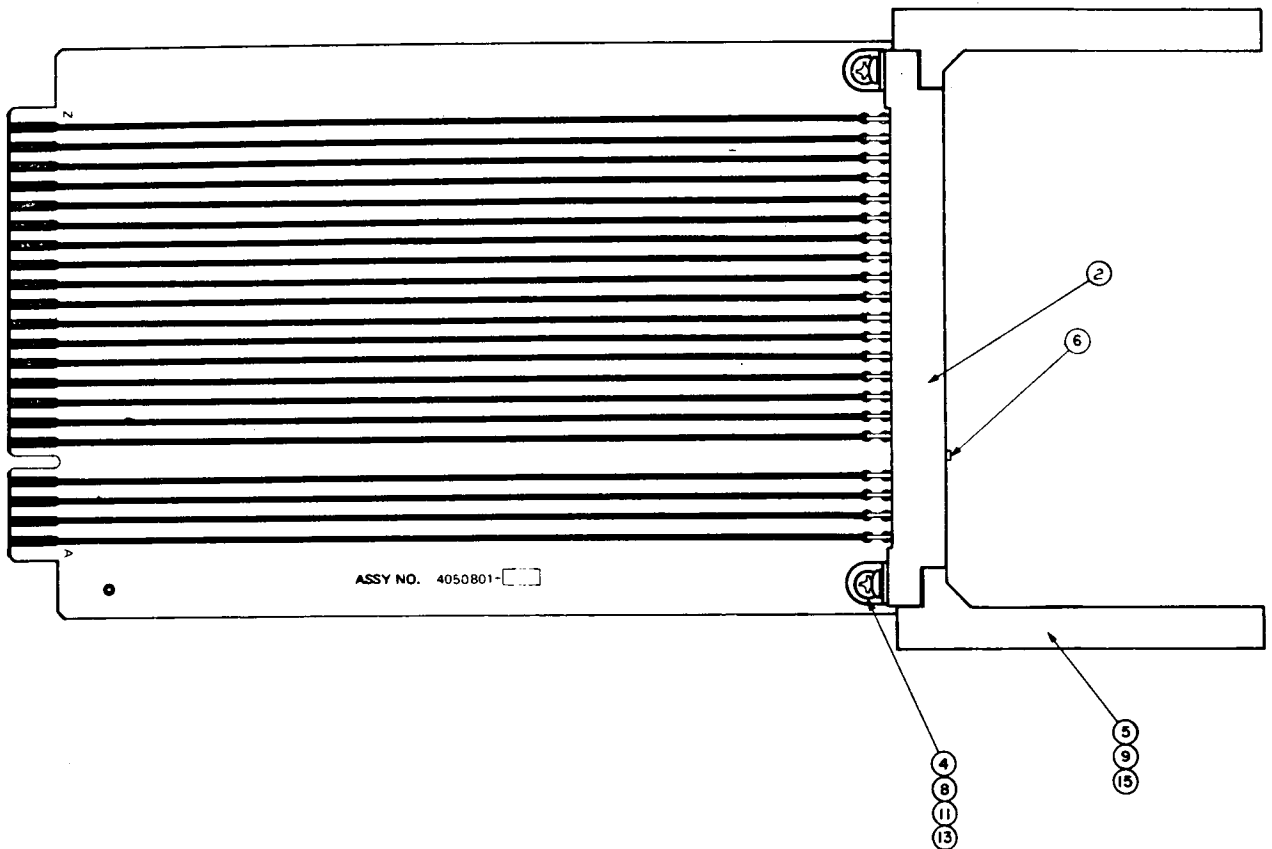

| ITEM NO. | AMPEX PART NO. | REFERENCE NUMBER | DESCRIPTION | JEDEC NO. OR MFR. PART NO. |
|-----------------------|-----------------------------------------------------------------------------------|------------------|--------------------------------------------------------------------------------------------------------------------------------------------------------------------------------------|----------------------------|
| 1 4 6 7 9 | 4050154-02 4020334-01 4030410-02 4952563-01 4952254-01 102-031 | | CONVERSION KIT, TWO INCH TO ONE INCH (NHA 4010239) ONE INCH HEAD ASSEMBLY, 8 CHANNEL GUIDE, 1 INCH, ROTARY TAPE RING, ADAPTER, FEEL, LOWER RING, HOLDDOWN REEL, EMPTY, 1 INCH | |

C

| ITEM NO. | AMPEX PART NO. | REFERENCE NUMBER | DESCRIPTION | JEDEC NO. OR MFR. PART NO. |
|----------|----------------|------------------|------------------------------------------------------|----------------------------|
| | 4020411-02 | | CONTROL BOX ASSEMBLY TRANSPORT ONLY (NHA 4010239) | |
| 2 | 4041211-02 | | CONNECTOR, CONTROL BOX, BRACKET ASSEMBLY | |
| 4 | 4050816-01 | | CONNECTOR HARNESS ASSEMBLY | |
| 5 | 6000035-01 | | LABEL | |
| 6 | 4100077-01 | | BUTTON, "RECORD" | |
| 7 | 4100077-02 | | BUTTON, "REWIND" | |
| 8 | 4100077-03 | | BUTTON, "PLAY" | |
| 9 | 4100077-04 | | BUTTON, "STOP" | |
| 10 | 4100077-05 | | BUTTON, "FAST FWD" | |
| 11 | 4100077-06 | | BUTTON, "LIFT DEFEAT" | |
| 12 | 283-082 | | STANDOFF, EXT/INT, 4-40 X 1.50 LG | |
| 14 | 4110297-02 | | OVERLAY | |
| 15 | 4260452-01 | | BRACKET, SWITCH | |
| 16 | 4330330-01 | | PLATE | |
| 17 | 4330331-01 | | BASE | |
| 18 | 4840426 | | SCHEMATIC | |
| 19 | 119-339 | S52-57 | SWITCH, BASE | OAK 585 |
| 20 | 121-223 | | NUT, HEX, PLAIN, SWITCH | |
| 21 | 060-530 | | LAMP, INCANDESCENT, 280V, 40 MA, T-1-3/4 BULB 385 | NO. 385 |
| 22 | 121-225 | | WASHER, LOCK, SWITCH | |
| 23 | 250-165 | | BUMPER, RUBBER | |
| 26 | 501-205 | | WASHER, PLAIN, NO. 8 | |
| 27 | 496-006 | | NUT, KEP, NO. 6-32 | |
| 28 | 310-740 | | CATCH ASSEMBLY | |
| 29 | 502-374 | | WASHER, LOCK, HELICAL SPRING, NO. 6 | |
| 30 | 470-018 | | SCREW, CAP, HEX SOC, 6-32 X 0.375 LG | |
| 31 | 471-061 | | SCREW, PAN HD, XREC, 4-40 X 0.312 LG | |
| 32 | 471-062 | | SCREW, PAN HD, XREC, 4-40 X 0.375 LG | |
| 33 | 471-328 | | SCREW, FLT HD, 4-40 X 0.375 LG | |
| 34 | 501-008 | | WASHER, PLAIN, NO. 4 | |
| 35 | 502-002 | | WASHER, LOCK, HELICAL SPRING, NO. 4 | |

C

SHEET 1 OF 1

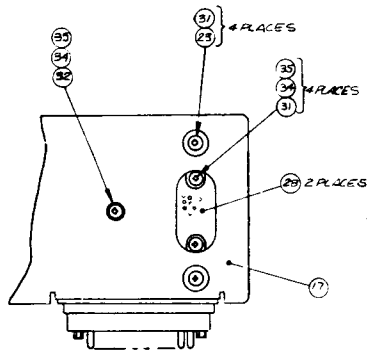

VIEW A-A

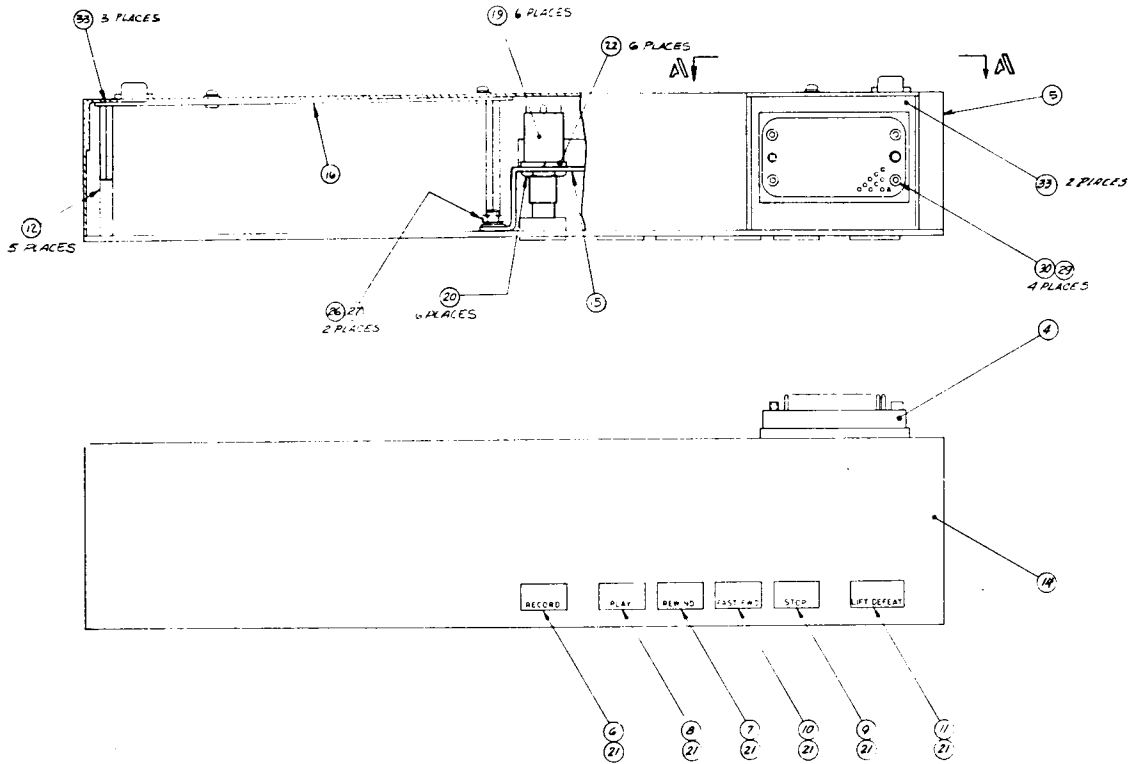

Assembly No. 4020411. Control Box Assembly (Transport Only)

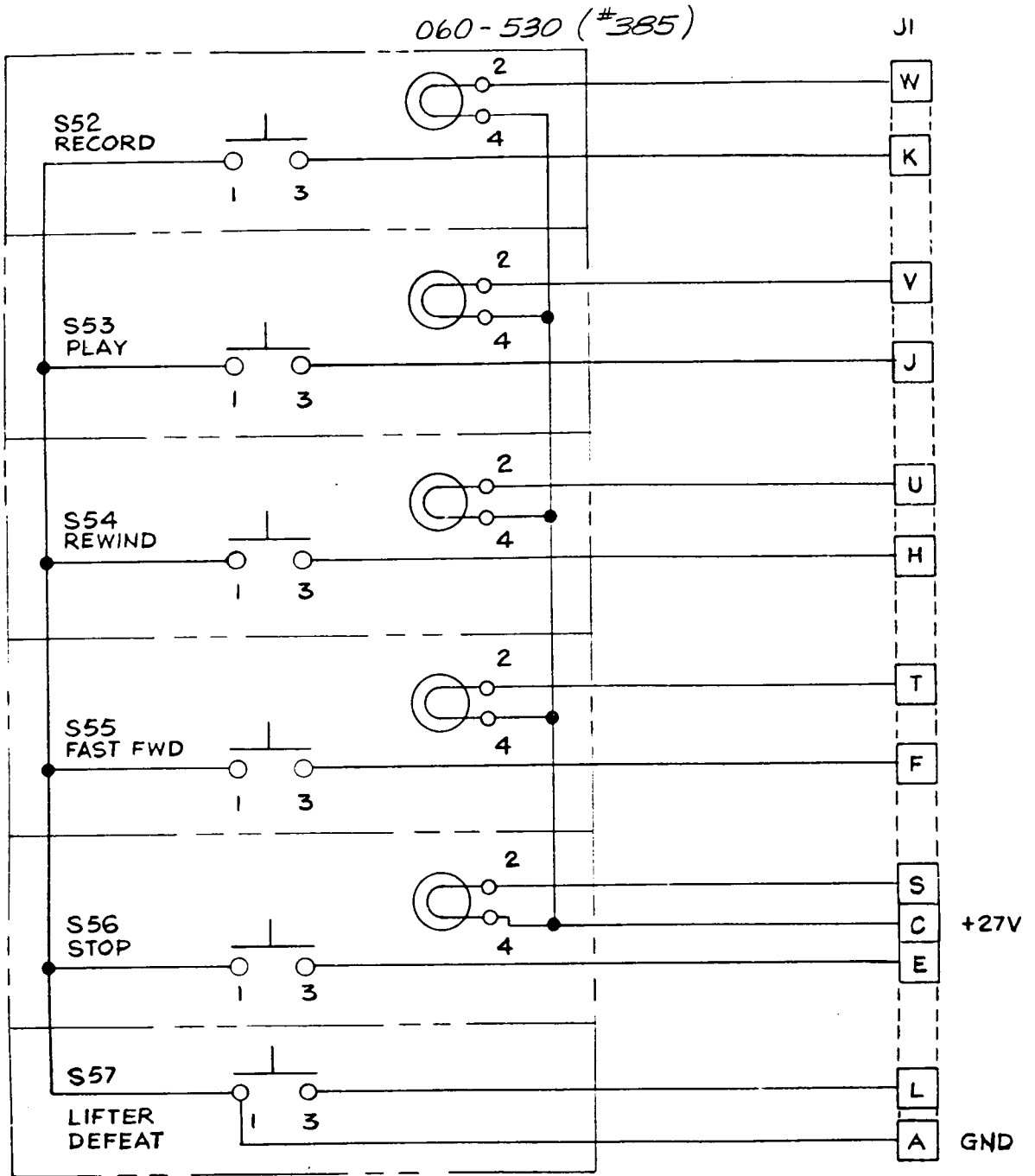

Schematic No. 4840426A. Control Box Assembly (Transport Only)

| ITEM NO. | AMPEX PART NO. | REFERENCE NUMBER | DESCRIPTION | JEDEC NO. OR MFR. PART NO. |
|----------|----------------|------------------|----------------------------------------------------------------|----------------------------|
| 1 | 4952348-02 | | REMOTE INTERCONNECT CABLE ASSEMBLY (NHA 4010239) | WITTEK 10H M |
| 3 | 4041261-01 | | REMOTE INTERCONNECT CONNECTOR ASSEMBLY, MALE | |
| 5 | 4041262-01 | | REMOTE INTERCONNECT CONNECTOR ASSEMBLY, FEMALE | |
| 6 | 169-143 | | CONTACT, PIN, CONNECTOR, 22 AWG | |
| 8 | 169-144 | | CONTACT, SOCKET, CONNECTOR, 22 AWG | |
| 9 | 262-007 | | BUSHING, SLEEVE, 0.75 I.D. X 0.927 O.D. X 2.125 LG X 1.314 FLG | |
| 9 | 302-522 | | CLAMP, BAND, GEAR | |

SHEET 1 OF 1

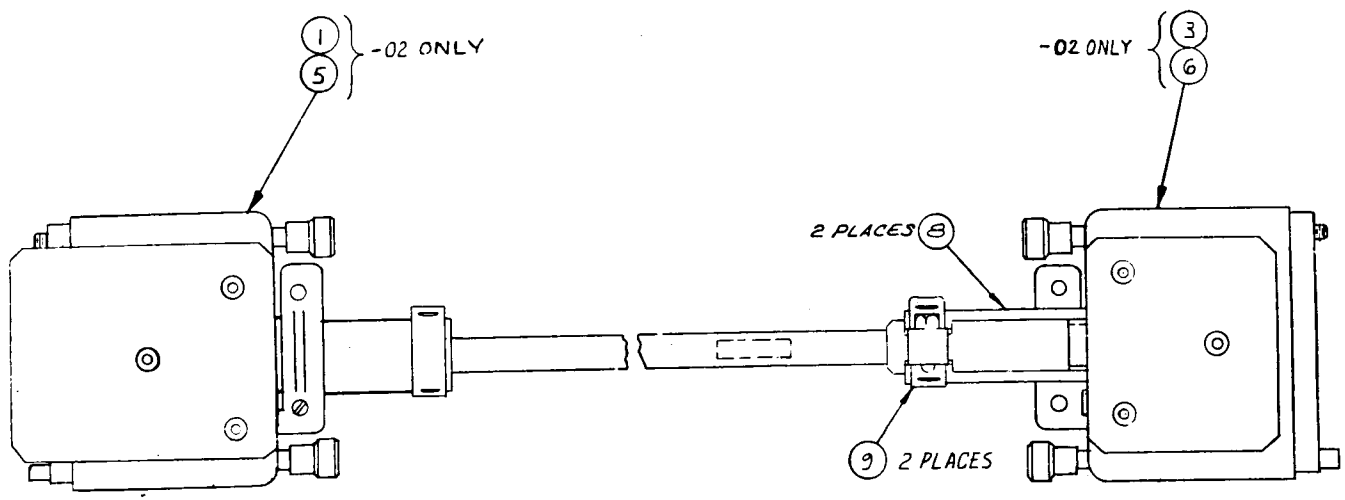

| ITEM NO. | AMPEX PART NO. | REFERENCE NUMBER | DESCRIPTION | JEDEC NO. OR MFR. PART NO. |
|----------|-----------------------|------------------|-------------------------------------------------------------------------------------|--------------------------------------|
| 1 | 4030414-01 592-447 | | BRUSH ASSEMBLY REPLACEMENT KIT AND PROCEDURE (NHA 4010239) BRUSH ASSEMBLY, MOTOR | PRINTED MOTORS, INC 26-100047-006 |
| 2 | 166-225 | | CONTACT, SOC, 16-18 AWG | |
| 3 | 265-078 | | BUSHING, STRAIN RELIEF | A |

SHEET 1 OF 1

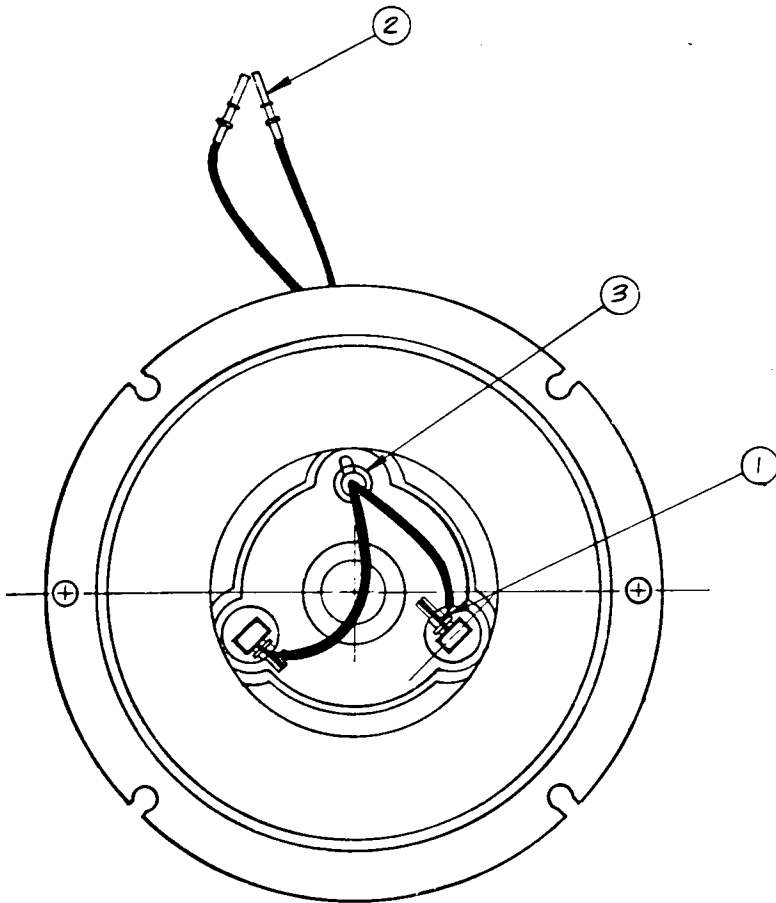

| ITEM NO. | AMPEX PART NO. | REFERENCE NUMBER | DESCRIPTION | JEDEC NO. OR MFR. PART NO. |
|----------|----------------|------------------|----------------------------------------|----------------------------|
| | 4050803-01 | | SWITCHER EXTENDER PWA (NHA 4010239) | |
| 2 | 4041263-01 | | BRACKET ASSY, PWB | |
| 4 | 143-925 | | CONNECTOR, SIGNAL CIRCUIT, RECP, P.C. | |
| 5 | 471-061 | | SCREW, PAN HD, XREC, 4-40 X 5/16 LG | |
| 6 | 471-064 | | SCREW, PAN HD, XREC, 4-40 X 1/2 IN. LG | |
| 7 | 496-004 | | NUT, KEP, NO. 4 | |
| 8 | 501-008 | | WASHER, PLAIN, NO. 4 | |
| 10 | 530-159 | | GUIDE, PCB | |
| 13 | 290-009 | | BRACKET, ANGLE, 90° | |
| 14 | 302-335 | | STRAP, CABLE | |

A

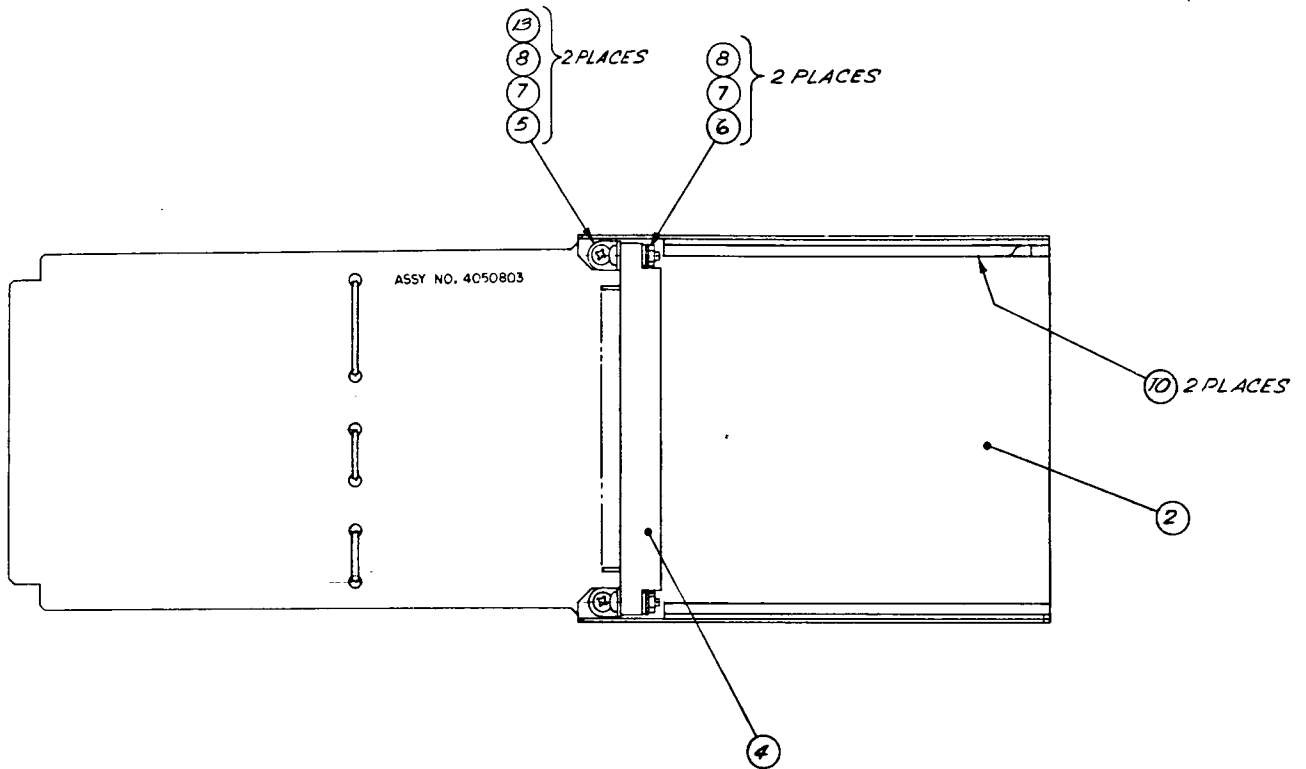

Assembly No. 4050803. Switcher Extender PWA

| ITEM NO. | AMPEX PART NO. | REFERENCE NUMBER | DESCRIPTION | JEDEC NO. OR MFR. PART NO. |
|----------|----------------|------------------|------------------------------------------------|----------------------------|
| | 4010242-02 | | OVERHEAD BRIDGE ASSEMBLY (NHA 4010239) | |
| 1 | 4041209 | | COVER ASSEMBLY, SUPPORT, ELECTRONICS | |
| 2 | 4260453-01 | | SUPPORT, LARGE | |
| 3 | 4260517-02 | | BRACKET, SUPPORT, BRIDGE | |
| 4 | 4260518-02 | | SHELF, BRIDGE | |
| 5 | 4330333-01 | | NUT PLATE | |
| 7 | 4220246-01 | | SPACER | |
| 8 | 4220306-01 | | BLOCK, SPACER | |
| 10 | 471-081 | | SCREW, PAN HD, XREC, 8-32 X 0.625 LG | |
| 12 | 470-531 | | SCREW, CAP, BUTTON HE, SOC DR, 10-32 X 0.50 LG | |
| 13 | 471-090 | | SCREW, PAN HD, XREC, 1/4 - 20 X 5/8 LG | |
| 14 | 470-149 | | SCREW, CAP, HEX SOC, 1/4 - 20 X 1-3/4 LG | |
| 16 | 501-067 | | WASHER, PLAIN, NO. 4 | |
| 17 | 501-070 | | WASHER, PLAIN, NO. 10 | |
| 18 | 501-205 | | WASHER, PLAIN, NO. 8 | |
| 19 | 501-009 | | WASHER, PLAIN, NO. 6 | |
| 20 | 502-004 | | WASHER, LOCK, SPLIT, NO. 8 | |
| 21 | 502-005 | | WASHER, LOCK, SPLIT, NO. 10 | |
| 22 | 502-006 | | WASHER, LOCK, NO. 1/4 | |
| 23 | 496-006 | | NUT, KEP, NO. 8 | |
| 24 | 496-005 | | NUT, KEP, NO. 6 | |
| 25 | 496-007 | | NUT, KEP, NO. 10 | |
| 26 | 471-071 | | SCREW, PAN HD, XREC, 6-32 X 0.50 LG | |
| 27 | 502-025 | | WASHER, INT TOOTH, NO. 6 | |
| 28 | 501-009 | | WASHER, PLAIN, NO. 6 | |
| 30 | 4041277-01 | | BRACKET ASSEMBLY, BRIDGE | |

E

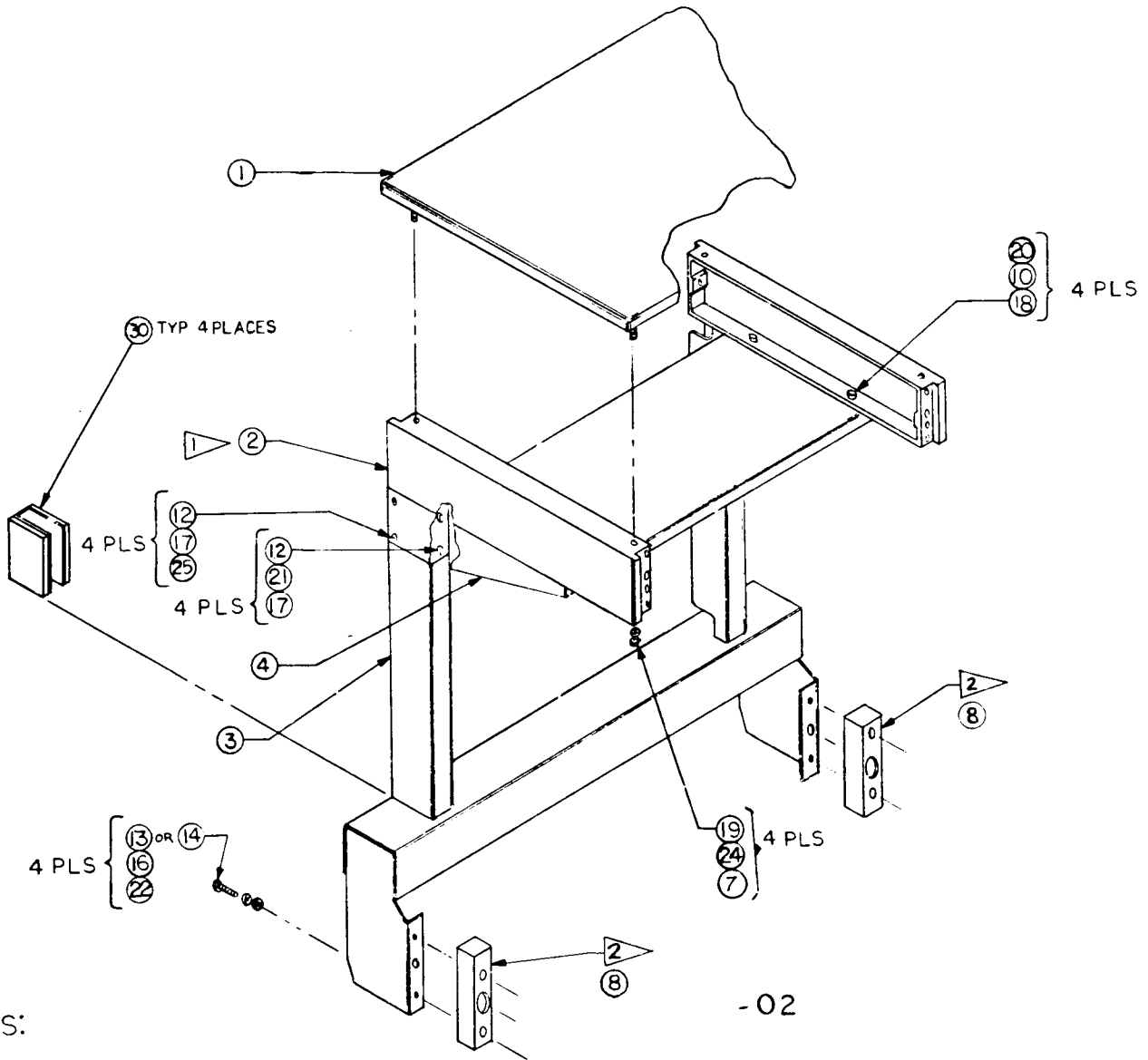

NOTES:

- ▶ ITEM 2 MAY BE STACKED FOR ADDITIONAL PANEL HEIGHT DO NOT EXCEED FOUR HIGH AND 100LBS OF ACCESSORIES. A KIT (P/N 4010244-0D CONSISTING OF TWO SIDE SUPPORT CASTINGS (ITEM 2) AND RELATED HARDWARE IS AVAILABLE
- ▶ BLOCK SPACER USED WHEN USING 16 INCH REELS ONLY (P/N FOR BLOCK IS 4220306-01,02 REQUIRED) USE 1 5/8 LG SCREW P/N 470-149 ITEM 14.

Assembly No. 4010242. Overhead Bridge Assembly

APPENDIX A

INTEGRATED CIRCUITS

Table A1. Integrated Circuit Ampex Part Numbers

| AMPEX PART NO. | MANUFACTURER'S PART NO. | MANUFACTURER | PAGE NO. |
|----------------|-------------------------|------------------------|----------|
| 581-357 | HP 5082-7730 | Hewlett-Packard | A2 |
| 581-425 | HP 5082-7732 | Hewlett-Packard | A2 |
| 586-075 | MC 7400 | Motorola | A2 |
| 586-077 | SN 7420N | Texas Instruments | A3 |
| 586-078 | SN 7430N | Texas Instruments | A3 |
| 586-108 | SN 7474 | Texas Instruments | A3 |
| 586-109 | MC 7402 | Motorola | A4 |
| 586-153 | MC 846P | Motorola | A4 |
| 586-268 | FC 741PC | Fairchild | A4 |
| 586-283 | SN 7493N | Texas Instruments | A5 |
| 586-303 | FC 9328DC | Fairchild | A6 |
| 586-309 | FC 9601DC | Fairchild | A6 |
| 586-326 | MC 7404 | Motorola | A7 |
| 586-425 | MC 853P | Motorola | A7 |
| 586-450 | SN 74164 | Texas Instruments | A8 |
| 586-554 | SN 7483 | Texas Instruments | A8 |
| 586-680 | SN 7413N | Texas Instruments | A9 |
| 586-698 | F u6A 9950 | Fairchild | A9 |
| 586-705 | SN 7486 | Texas Instruments | A9 |
| 586-713 | FC 7407PC | Fairchild | A10 |
| 586-756 | LM 309 | National Semiconductor | A10 |
| 586-759 | SN 7408N | Texas Instruments | A10 |
| 586-795 | MC 665 | Motorola | A11 |
| 586-797 | SN 74123 | Texas Instruments | A11 |
| 586-871 | SN 7413J | Texas Instruments | A12 |
| 586-890 | SN 7417 | Texas Instruments | A12 |
| 586-906 | SN 74191 | Texas Instruments | A13 |
| 586-925 | SN 74175 | Texas Instruments | A14 |
| 587-051 | SN 7425N | Texas Instruments | A15 |
| 587-086 | LM311 | National Semiconductor | A15 |
| 587-101 | MC 661 | Motorola | A16 |
| 587-102 | MC 668 | Motorola | A16 |
| 587-103 | MC 680 | Motorola | A17 |
| 587-147 | SN 7414 | Texas Instruments | A17 |
| 587-266 | SN 74279 | Texas Instruments | A18 |
| 587-458 | LM 324 | National Semiconductor | A19 |
| 587-544 | SN 7447N | Texas Instruments | A20 |

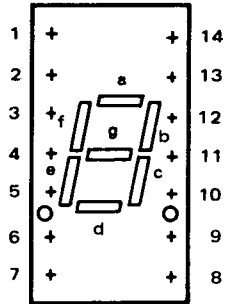

| PIN | FUNCTION |
|-----|--------------|
| 1 | CATHODE - a |
| 2 | CATHODE - f |
| 3 | ANODE * |
| 4 | NO PIN |
| 5 | NO PIN |
| 6 | CATHODE - dp |
| 7 | CATHODE - e |
| 8 | CATHODE - d |
| 9 | NO CONN. |
| 10 | CATHODE - c |
| 11 | CATHODE - g |
| 12 | NO PIN |
| 13 | CATHODE - b |
| 14 | ANODE * |

*REDUNDANT ANODES

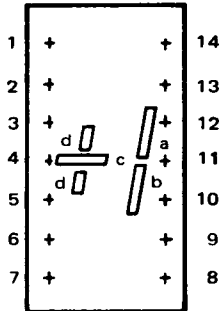

| PIN NO. | FUNCTION |
|---------|---------------------|
| 1 | ANODE c,d |
| 2 | NO PIN |
| 3 | NO PIN |
| 4 | INTERNAL CONNECTION |
| 5 | NO PIN |
| 6 | NO PIN |
| 7 | CATHODE d |
| 8 | CATHODE c |
| 9 | CATHODE dp |
| 10 | CATHODE a-b |
| 11 | INTERNAL CONNECTION |
| 12 | NO PIN |
| 13 | NO PIN |
| 14 | ANODE a,b, dp |

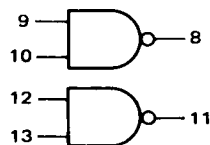
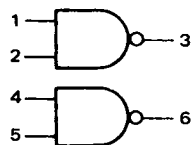

PIN 7 = GND
PIN 14 = $V_{CC}(+5V)$
3 = 1.2

TEXAS INSTRUMENTS
SN 7420 N

AMPEX
586-077

4-INPUT
NAND GATE

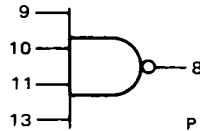
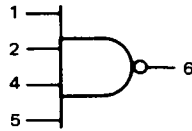

PIN 7 = GND
PIN 14 = V_{cc}
6 = 1.2.4.5

TEXAS INSTRUMENTS
SN 7430 N

AMPEX
586-078

8-INPUT
NAND GATE

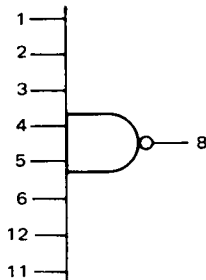

Pin 7 = GND
PIN 14 = V_{cc}

8 = (1)(2)(3)(4)(5)(6)(11)(12)

TEXAS INSTRUMENTS
SN 7474

AMPEX
586-108

DUAL D-TYPE EDGE-
TRIGGERED FLIP-FLOP

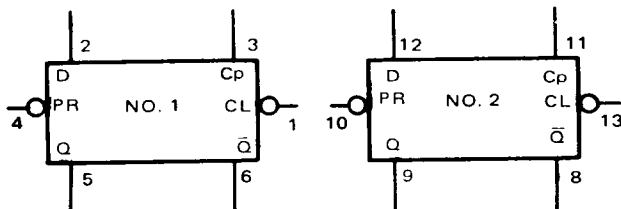

PIN 7 = GND
PIN 14 = V_{cc}

PR = PRESET
CL = CLEAR
Cp = CLOCK

| | | | |
|-------|-----------|----|----|
| t_n | t_{n+1} | | |
| D | Q | PR | CL |
| L | L | L | H |
| H | H | H | L |
| | | L | ND |

t_{n+1} IS TIME AFTER POSITIVE
TRANSITION OF CLOCK

MOTOROLA
MC 7402

AMPEX
586-109

QUAD 2-INPUT
NOR GATE

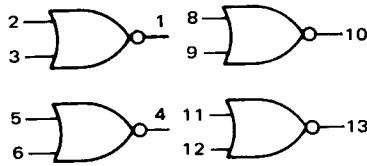

1 = $\overline{2+3}$
PIN 7 = GND
PIN 14 = V_{CC} (5V)

MOTOROLA
MC 846 P

AMPEX
586-153

QUAD 2-INPUT
NAND GATE

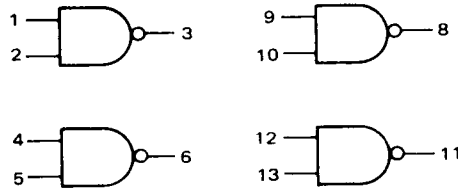

$3 = \overline{1} + \overline{2}$
 $H = L + L$
 $L = H \cdot H$

PIN 7 = GND
PIN 14 = +5V

FAIRCHILD
FC 741 PC

AMPEX
586-268

OPERATIONAL
AMPLIFIER

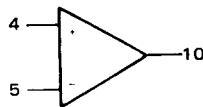

1,2,7,8
12,13,14 NO CONNECTION

PIN 6 = - SUPPLY
PIN 11 = +SUPPLY

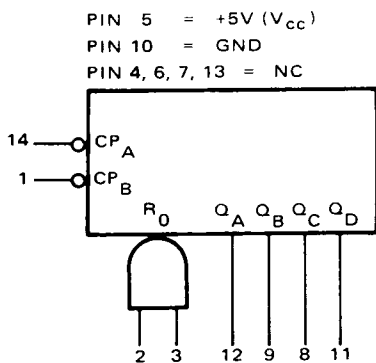
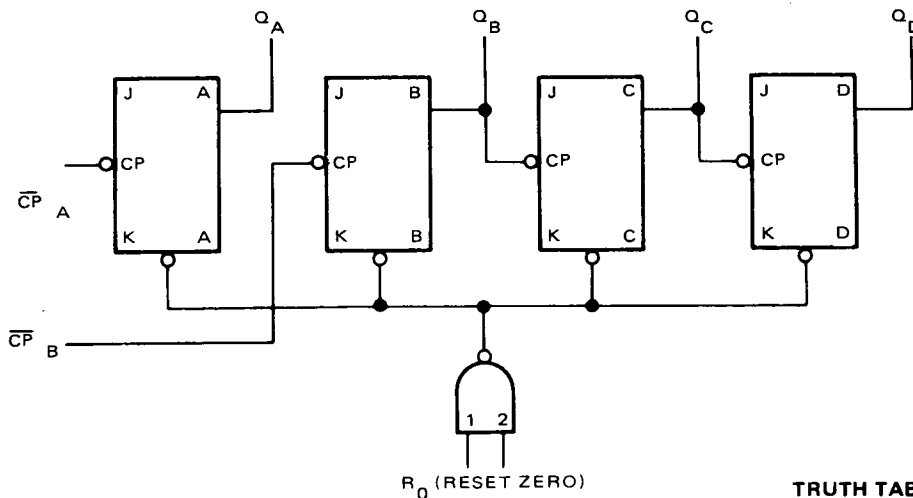

TRUTH TABLE
SEE NOTES 1, 2, AND 3)

| COUNT | OUTPUT | | | |
|-------|----------------|----------------|----------------|----------------|
| | Q _D | Q _C | Q _B | Q _A |
| 0 | L | L | L | L |
| 1 | L | L | L | H |
| 2 | L | L | H | L |
| 3 | L | L | H | H |
| 4 | L | H | L | L |
| 5 | L | H | L | H |
| 6 | L | H | H | L |
| 7 | L | H | H | H |
| 8 | H | L | L | L |
| 9 | H | L | L | H |
| 10 | H | L | H | L |
| 11 | H | L | H | H |
| 12 | H | H | L | L |
| 13 | H | H | L | H |
| 14 | H | H | H | L |
| 15 | H | H | H | H |

NOTES:

1. OUTPUT Q_A CONNECTED TO INPUT \overline{CP}_B .
2. TO RESET ALL OUTPUTS TO LOW LEVEL BOTH R₀₍₁₎ AND R₀₍₂₎ INPUTS MUST BE AT HIGH LEVEL STATE.
3. EITHER (OR BOTH) RESET INPUTS R₀₍₁₎ AND R₀₍₂₎ MUST BE AT A LOW LEVEL TO COUNT.

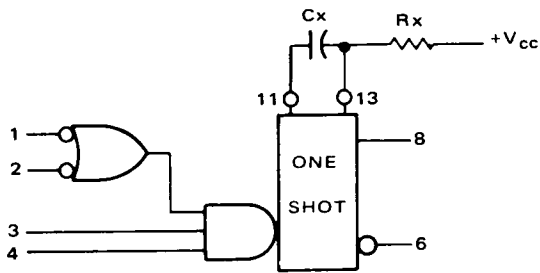
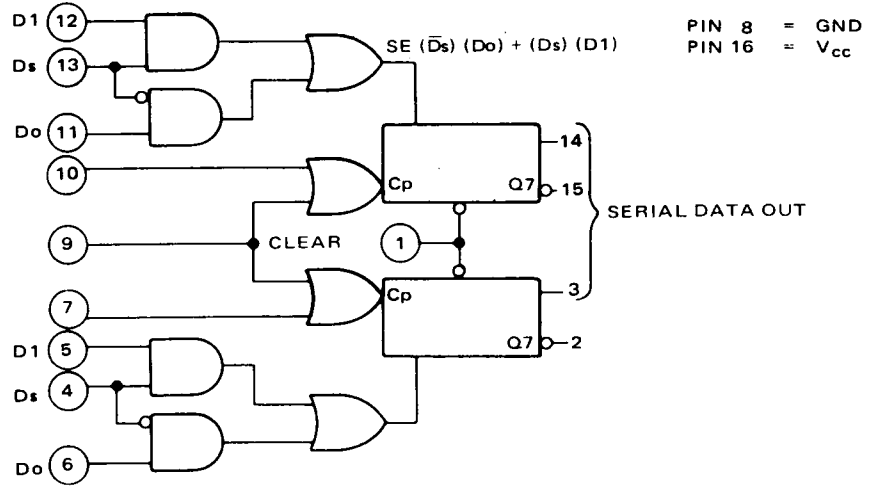

PIN 7 = GND
PIN 14 = V_{CC}

$$PW = 0.36 R_x C_x$$

$$T(ns) = 0.32 R_x C_x (1 + 0.7/R_x)$$

C_x IN pF
R_x IN K

WITH TRANSISTOR OR DIODE
ACROSS C_x (WHEN LARGE VALUES ARE USED):

$$T(ns) = 0.36 C_x R_x (1 + 0.7/R_x)$$

MOTOROLA
MC 7404

AMPEX
586-326

HEX
INVERTER

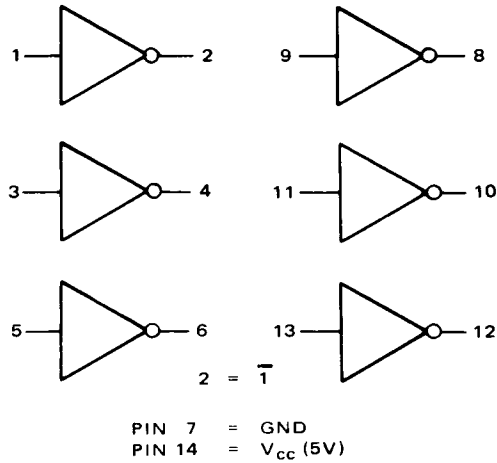

MOTOROLA
MC 853 P

AMPEX
586-425

DUAL J-K
FLIP-FLOP

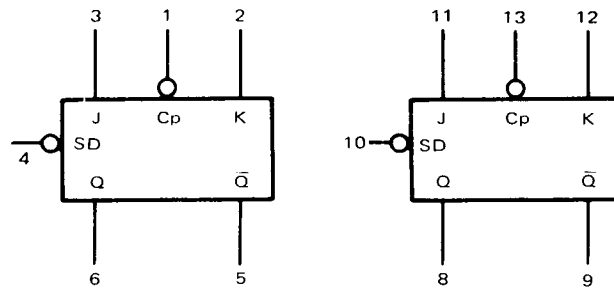

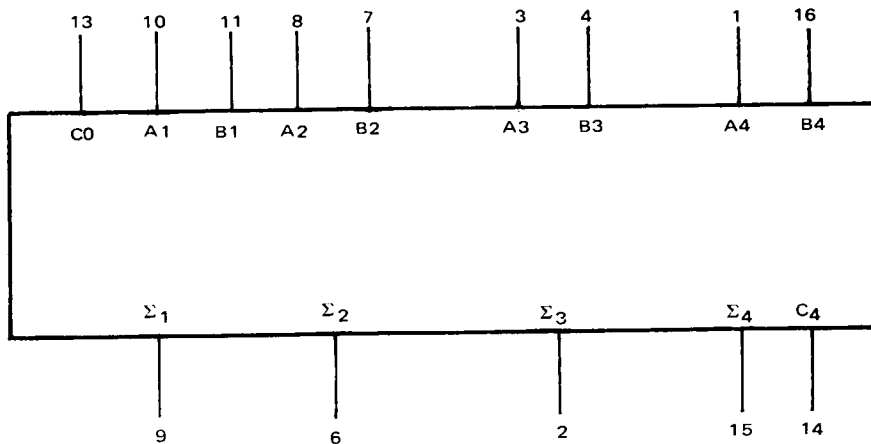
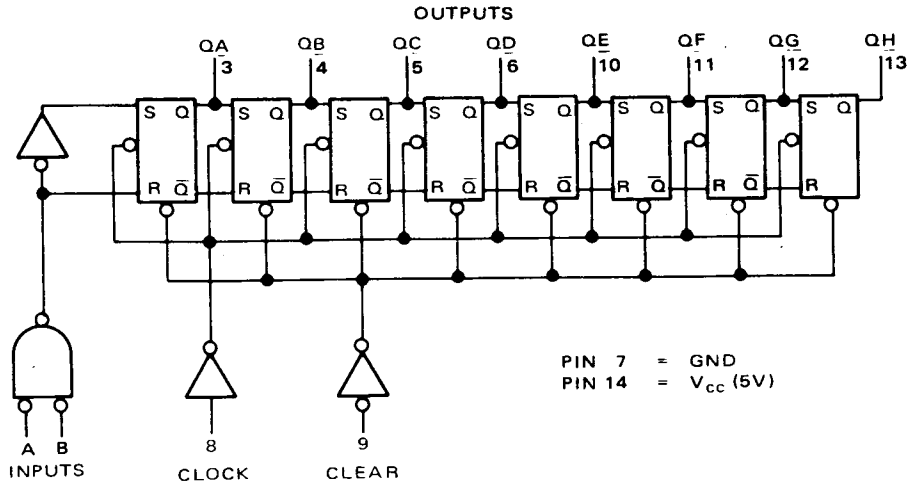

$$A_1 + B_1 + C_0 = \Sigma_1 \text{ AND } C_1 \text{ (INTERNAL)}$$

$$A_2 + B_2 + C_1 = \Sigma_2 \text{ AND } C_2 \text{ (INTERNAL)}$$

$$A_3 + B_3 + C_2 = \Sigma_3 \text{ AND } C_3 \text{ (INTERNAL)}$$

$$A_4 + B_4 + C_3 = \Sigma_4 \text{ AND } C_4$$

PIN 5 = V_{CC}
PIN 12 = GND



PIN 14 = +5V (V_{cc})
PIN 7 = GND

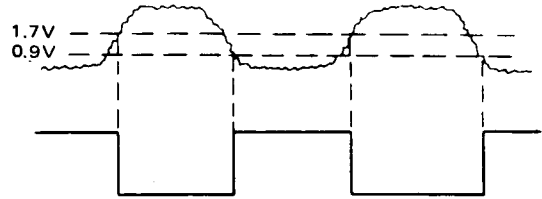

POSITIVE LOGIC:

$$6 = 1 \cdot 2 \cdot 4 \cdot 5$$



POSITIVE-GOING THRESHOLD = 1.7V
NEGATIVE-GOING THRESHOLD = 0.9V

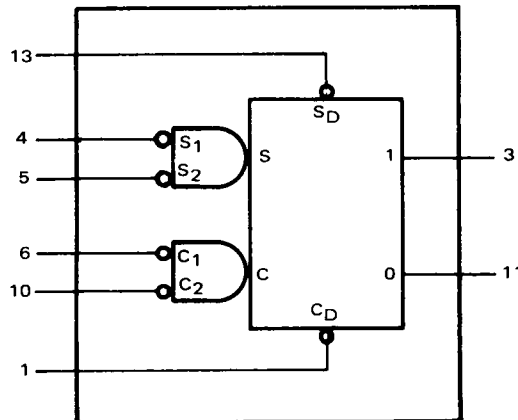

PIN 7 = GND
PIN 14 = +5V (V_{cc})

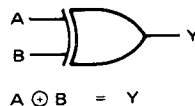

| A | B | Y |
|----|----|----|
| 1 | 2 | 3 |
| 4 | 5 | 6 |
| 9 | 10 | 8 |
| 12 | 13 | 11 |

PIN 7 = GND
PIN 14 = V_{cc}

FAIRCHILD
FC 7407 PC

AMPEX
586-713

HEX BUFFER/DRIVER
WITH OPEN-COLLECTOR
HIGH-VOLTAGE OUTPUT

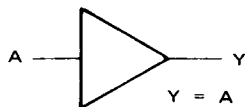

HEX BUFFER

PIN 7 = GND
PIN 14 = V_{cc}

| A | Y |
|----|----|
| 1 | 2 |
| 3 | 4 |
| 5 | 6 |
| 9 | 8 |
| 11 | 10 |
| 13 | 12 |

NATIONAL SEMICONDUCTOR
LM 309

AMPEX
586-756

5-VOLT
REGULATOR

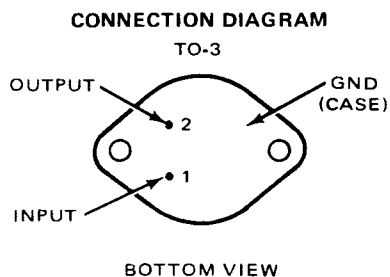
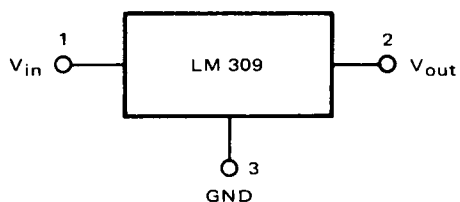

TEXAS INSTRUMENTS
SN 7408 N

AMPEX
586-759

QUAD 2-INPUT
AND GATE

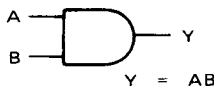

| | | | | |
|---|---|---|----|----|
| A | 1 | 4 | 9 | 12 |
| B | 2 | 5 | 10 | 13 |
| Y | 3 | 6 | 8 | 11 |

PIN 7 = GND
PIN 14 = V_{cc}

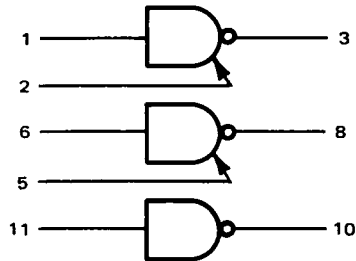

PIN 14 = +15V, (V_{cc})
 PIN 7 = GND
 POSITIVE LOGIC: 3-1 • (2)
 NEGATIVE LOGIC: 3-1 + (2)

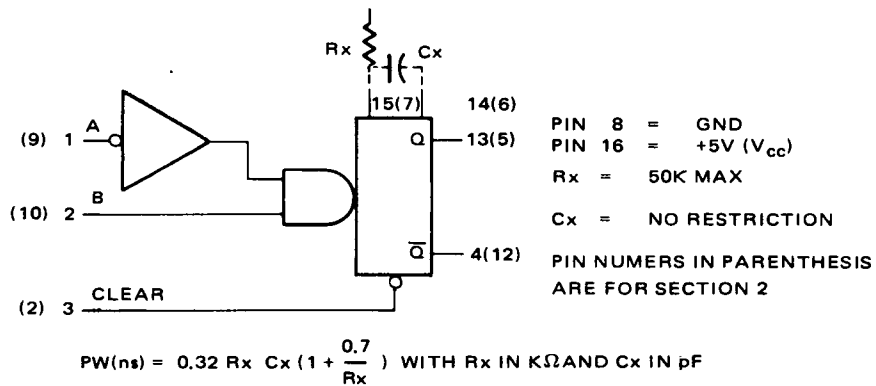



PIN 14 = +5V (V_{CC})
PIN 7 = GND

POSITIVE LOGIC:

$$6 = 1 \cdot 2 \cdot 4 \cdot 5$$

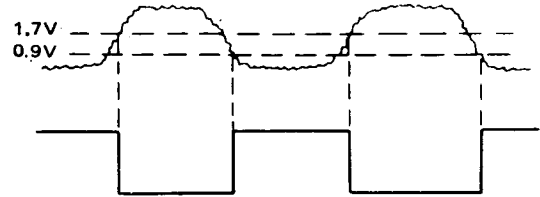

POSITIVE-GOING THRESHOLD = 1.7V
NEGATIVE-GOING THRESHOLD = 0.9V

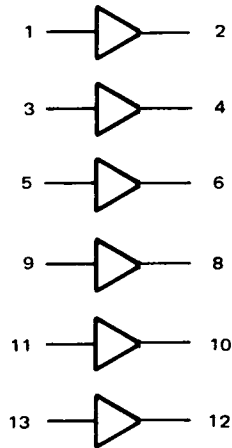

PIN 14 = +5V (V_{CC})
PIN 7 = GND

POSITIVE LOGIC:
 $2 = 1$

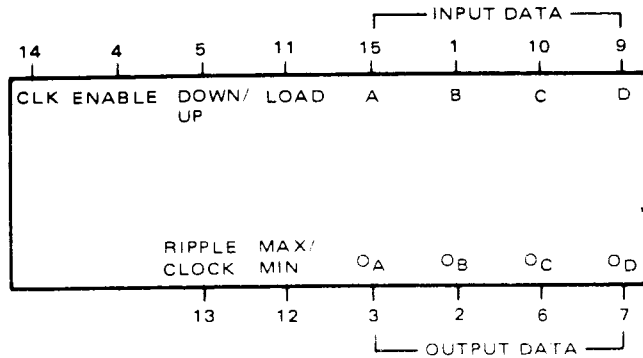

PIN 16 = +5V (V_{CC})
PIN 8 = GND
ASYNCHRONOUS INPUTS: LOW
INPUT TO LOAD SETS $O_A = A$,
 $O_B = B$, $O_C = C$, AND $O_D = D$.

TYPICAL LOAD, COUNT, AND INHIBIT SEQUENCES

THE FOLLOWING SEQUENCE ILLUSTRATES LOGIC LEVELS AND FUNCTIONS.

1. LOAD (PRESET) TO BINARY THIRTEEN
2. COUNT UP TO FOURTEEN, FIFTEEN (MAXIMUM), ZERO, ONE, AND TWO.
3. INHIBIT.
4. COUNT DOWN TO ONE, ZERO (MINIMUM), FIFTEEN, FOURTEEN, AND THIRTEEN.

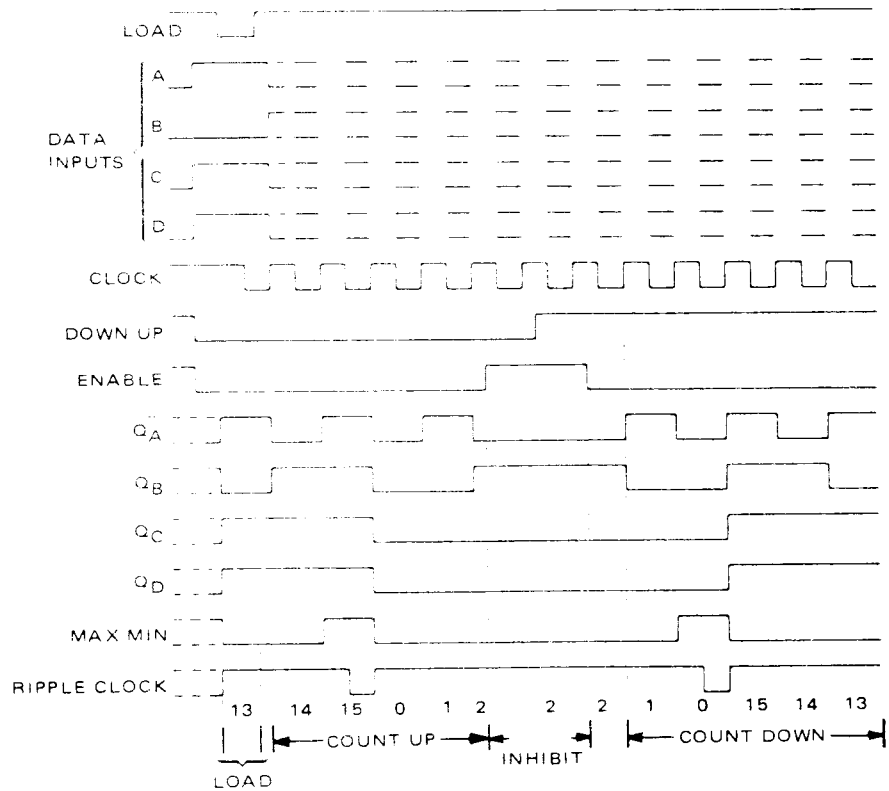

PIN 16 = +5V (V_{CC})
PIN 8 = GND

FUNCTION TABLE
(EACH FLIP-FLOP)

| INPUTS | | | OUTPUTS | |
|--------|------------|---|---------|-------------|
| CLEAR | CLOCK | D | Q | \bar{Q} |
| L | X | X | L | \bar{H} |
| H | \uparrow | H | H | L |
| H | \uparrow | L | L | H |
| H | L | X | Q_0 | \bar{Q}_0 |

- H = HIGH LEVEL (STEADY STATE)
- L = LOW LEVEL (STEADY STATE)
- X = IRRELEVANT
- \uparrow = TRANSITION FROM LOW TO HIGH LEVEL
- Q_0 = THE LEVEL OF Q BEFORE THE INDICATED STEADY-STATE INPUT CONDITIONS WERE ESTABLISHED.

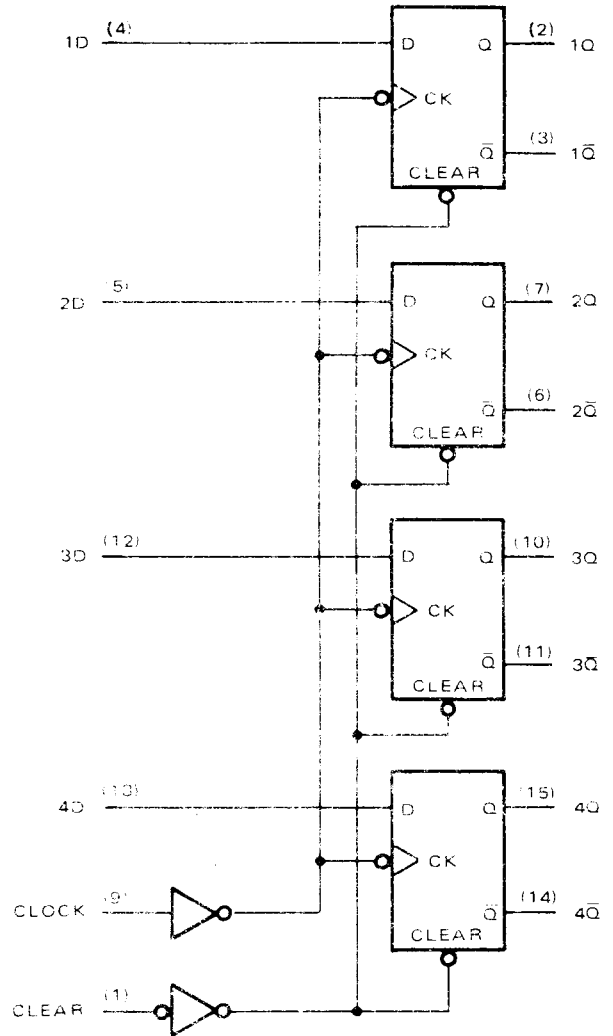

TRUTH TABLE

| IN | | | | | OUT |
|----|---|---|---|---|-----|
| A | B | C | D | G | Y |
| H | X | X | X | H | L |
| X | H | X | X | H | L |
| X | X | X | X | H | L |
| X | X | H | X | H | L |
| X | X | X | H | H | L |
| L | L | L | L | X | H |
| X | X | X | X | L | H |

X = DON'T CARE

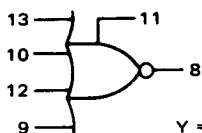
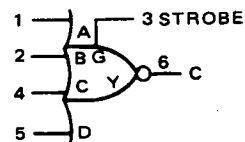

PIN 7 = GND
PIN 14 = V_{CC}

$$Y = \overline{(G)(A+B+C+D)} = \overline{G} + \overline{A}\overline{B}\overline{C}\overline{D}$$

DUAL-IN-LINE PACKAGE

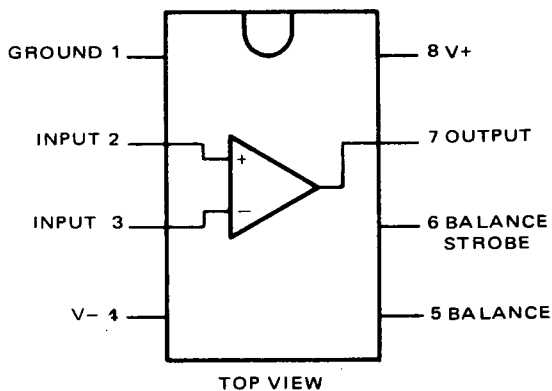

MOTOROLA
MC 661

AMPEX
587-101

EXPANDABLE DUAL
4-INPUT "NAND" GATE
(PASSIVE PULLUP)

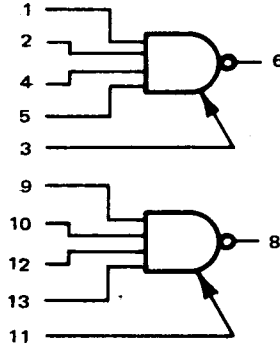

PIN 14 = +15V (V_{CC})
PIN 7 = GND

POSITIVE LOGIC $6 = \overline{1 \cdot 2 \cdot 4 \cdot 5 \cdot (3)}$

MOTOROLA
MC 668

AMPEX
587-102

QUAD 2-INPUT
NAND GATE
(PASSIVE PULLUP)

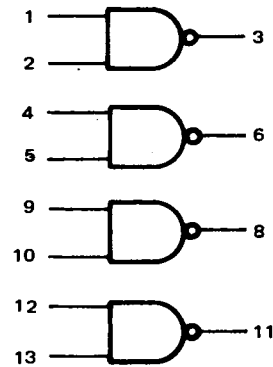

PIN 14 = +15V (V_{CC})
PIN 7 = GND

POSITIVE LOGIC: $3 = \overline{1 \cdot 2}$

MOTOROLA
MC 680

AMPEX
587-103

HEX INVERTER
(ACTIVE PULLUP)

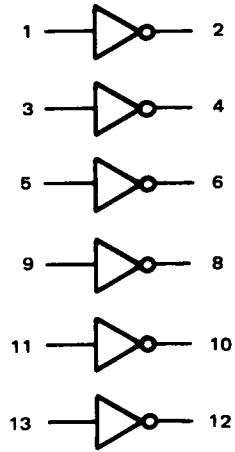

PIN 14 = +15 (V_{cc})
PIN 7 = GND

TEXAS INSTRUMENTS
SN7414

AMPEX
587-147

HEX SCHMITT
TRIGGER INVERTER

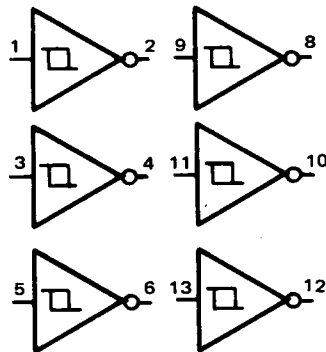

POSITIVE-GOING THRESHOLD = 1.7V
NEGATIVE-GOING THRESHOLD = 0.9V

PIN 7 = GND
PIN 14 = +5V

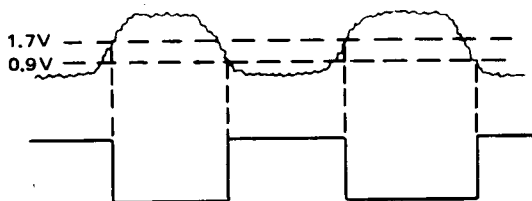

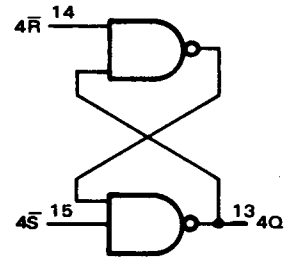
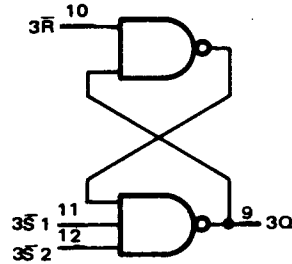
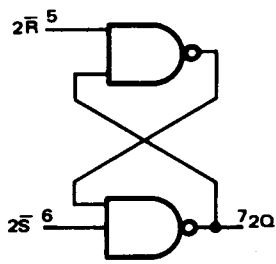
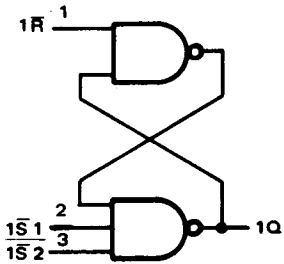

FUNCTION TABLE

| INPUTS \bar{S} \bar{R} | OUTPUT Q |
|-------------------------------|-------------|
| H H | Q_0 |
| L H | H |
| H L | L |
| L L | H^* |

H = HIGH

L = LOW LEVEL

Q_0 = THE LEVEL OF Q BEFORE THE INDICATED INPUT CONDITIONS WERE ESTABLISHED.

*THIS OUTPUT LEVEL IS PSEUDO STABLE, THAT IS, IT MAY NOT PERSIST WHEN THE \bar{S} AND \bar{R} INPUTS RETURN TO THEIR INACTIVE (HIGH) LEVEL.

†FOR LATCHES WITH DOUBLE \bar{S} INPUTS:

H = BOTH \bar{S} INPUTS HIGH

L = ONE OR BOTH \bar{S} INPUTS LOW

PIN 16 = +5V (V_{CC})

PIN 8 = GND

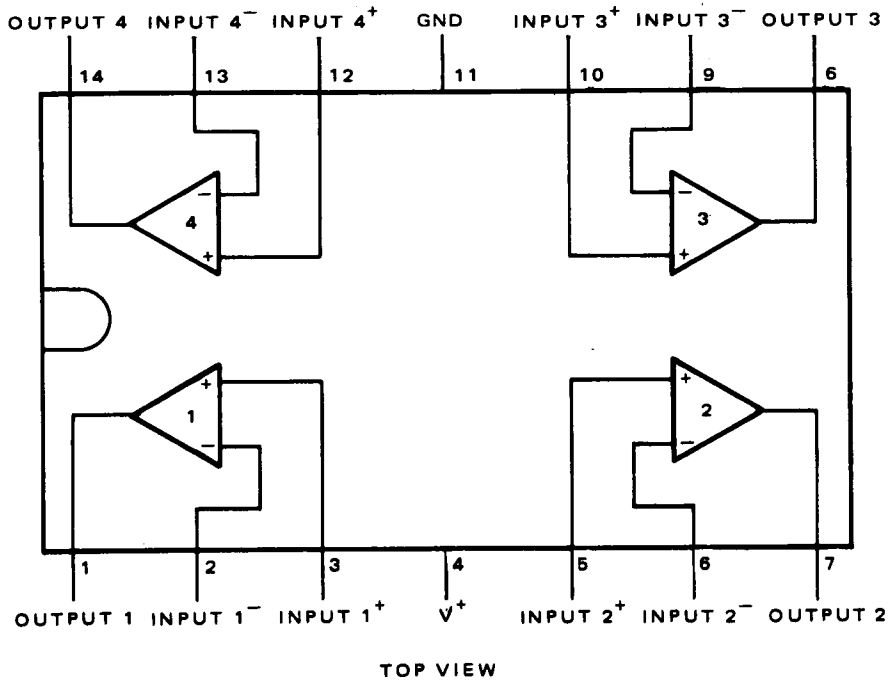

PIN 4 = V_{CC}
PIN 11 = GND

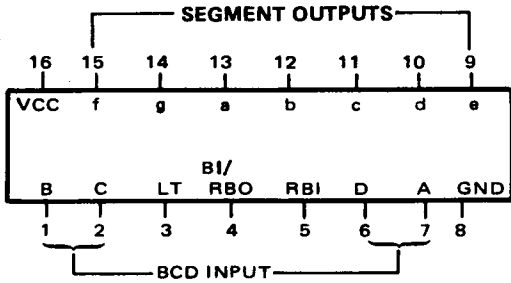

PIN 16 = +5V (V_{cc})
 PIN 8 = GND
 LT = LAMP TEST
 BI/RBO = BLANKING INPUT/RIPPLE BLANKING
 OUTPUT: WIRE-AND SERVING AS
 BLANKING INPUT (BI) AND/OR
 RIPPLE BLANKING OUTPUT (RBO)
 RBI = RIPPLE BLANKING INPUT

FUNCTION TABLE

| DECIMAL OR FUNCTION | INPUTS | | | | | | BI/RBO† | OUTPUTS | | | | | | | | |
|---------------------------|--------|-----|---|---|---|---|---------|---------|-----|-----|-----|-----|-----|-----|-----|-----|
| | LT | RBI | D | C | B | A | | a | b | c | d | e | f | g | | |
| 0 | H | H | L | L | L | L | H | ON | ON | ON | ON | ON | OFF | OFF | OFF | OFF |
| 1 | H | X | L | L | L | H | H | OFF | ON | ON | ON | OFF | OFF | OFF | OFF | OFF |
| 2 | H | X | L | L | H | L | H | ON | ON | OFF | ON | ON | OFF | OFF | ON | ON |
| 3 | H | X | L | L | H | H | H | ON | ON | ON | ON | ON | OFF | OFF | ON | ON |
| 4 | H | X | L | H | L | L | H | OFF | ON | ON | OFF | OFF | ON | ON | ON | ON |
| 5 | H | X | L | H | L | H | H | ON | OFF | ON | ON | ON | OFF | ON | ON | ON |
| 6 | H | X | L | H | H | L | H | ON | OFF | ON | ON | ON | ON | ON | ON | ON |
| 7 | H | X | L | H | H | H | H | ON | ON | ON | OFF | OFF | OFF | OFF | OFF | OFF |
| 8 | H | X | H | L | L | L | H | ON | ON | ON | ON | ON | ON | ON | ON | ON |
| 9 | H | X | H | L | L | H | H | ON | ON | ON | OFF | OFF | ON | ON | ON | ON |
| BI | X | X | X | X | X | X | L | OFF | OFF | OFF | OFF | OFF | OFF | OFF | OFF | OFF |
| RBI | H | L | L | L | L | L | L | OFF | OFF | OFF | OFF | OFF | OFF | OFF | OFF | OFF |
| LT | L | X | X | X | X | X | H | ON | ON | ON | ON | ON | ON | ON | ON | ON |

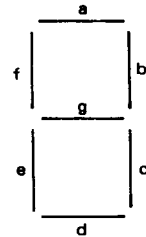

SEGMENT
IDENTIFICATION

APPENDIX B

TRANSPORT CONTROL PWA 4050706 ALIGNMENT

The transport control electronics do not require periodic adjustment. If the transport does not function properly, refer to *Troubleshooting*, paragraph 5-53, for probable cause and remedy. If any electronic components or mechanical components in the transport control PWA or the transport mechanism are replaced, perform the following procedures as necessary to ensure correct operation.

B-1. PRELIMINARY SETUP

Perform the following procedures to prepare the transport control and transport mechanism for normalizing and tension adjustments.

1. Remove power from the recorder/reproducer.
2. Check calibration of tension sensor arm in accordance with the *Tension Sensor Arm Calibration*, paragraph B-10.
3. Remove the transport control PWA (Figure B-1) from its connector and reinstall it using an extender board, part no. 4050695-04.
4. Referring to Figure B-1, position potentiometers R1 through R6 and R10 fully counterclockwise, R7 and R8 fully clockwise, and R9 to mid-position.
5. Secure the end-of-tape arm out of the tape path using masking tape, but do not actuate the tape-threading switch.

NOTE

Reel servo normalizing and tension adjustments are affected by the power supply voltages. Ensure that power supply voltages are within tolerances prior to performing the following normalizing

and tension adjustment procedures. Refer to the *Power Supply Adjustment* procedures, paragraph 5-8, for power supply voltage tolerances.

B-2. NORMALIZING REEL SERVOS

Normalize reel servos as follows:

1. Apply power to the recorder/reproducer.
2. Adjust the SUP GAIN potentiometer (R7) (Figure B-1) until the torque on the supply reel just reduces to zero, as observed by no reel motion.
3. Place the recorder/reproducer in the rewind mode, and adjust T-UP GAIN potentiometer R8 (Figure B-1) until the torque on the take-up reel just reduces to zero (no reel motion).
4. Remove power from the recorder/reproducer and remove the masking tape from the end-of-tape arm.

B-3. TENSION ADJUSTMENTS

Since tension adjustments are dependent on associated gain and normalizing adjustments, it is advisable to check all tensions after making any adjustments to the transport control electronics. Check and adjust transport tensions according to the following procedures.

B-4. Stop Tension – Not Using Tension Meter

To set stop tension with the use of a tension meter, proceed as follows:

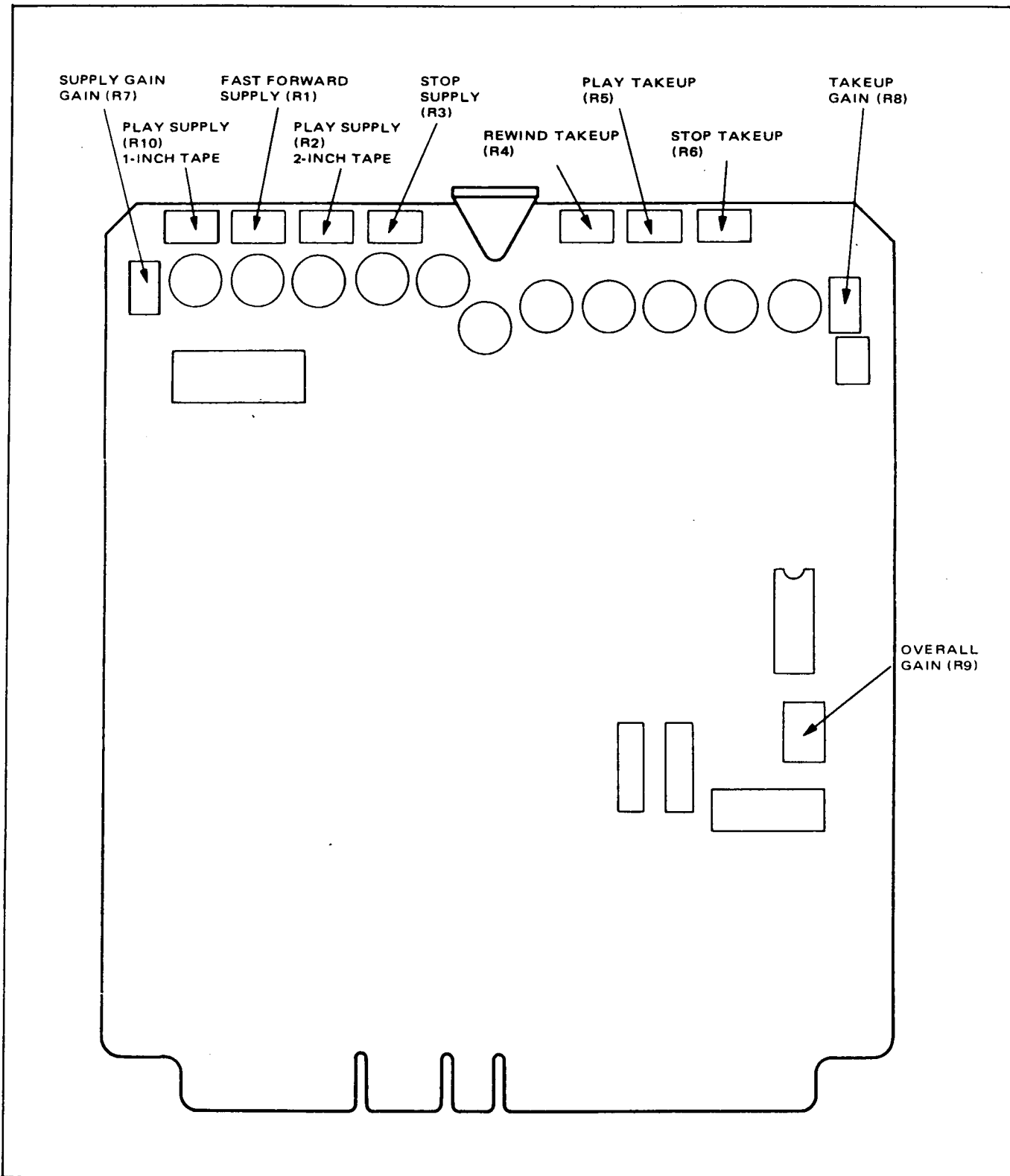

Figure B-1. Transport Control PWA, Control Locations

NOTE

The tension sensor arm is calibrated at the factory. If the position of the tension sensor arm (Figure B-2) is changed, or the adjustment specified in step 2 of the following *Stop Tension* adjustment procedure cannot be achieved, perform the *Tension Sensor Arm Calibration* procedure, paragraph B-10.

1. Thread a reel of tape onto the transport (see Figure B-1), using the largest reel size expected to be used (up to 16 inches). Wrap only two turns of tape onto the takeup reel.
2. While holding the takeup reel to restrain movement, apply power to the recorder/reproducer and adjust the stop supply tension potentiometer (R3) until the alignment surface of the tension sensor arm (Figure B-3) is aligned with the one-inch or two-inch alignment mark, according to tape width on the tension sense label.

NOTE

If the transport exhibits a tendency to oscillate during these adjustments, re-

adjust the GAIN potentiometer (R9) until the oscillations cease. This adjustment should be made with a minimum tape pack on the supply reel, using the smallest available reel.

3. With maximum tape pack on the supply reel, adjust the stop takeup potentiometer (R6) until the tension on the takeup reel increases sufficiently to cause the tape to move forward. Then, decrease tension until the tape just stops and exhibits no tendency to move forward. This balances the stop mode tensions and the tape should not move in the stop mode regardless of tape pack.

B-5. Stop Tension – Using Tension Meter

If a tape tension meter, Tentel Model T2-H20-2 or equivalent, is available, the following procedure may be used to set stop tension.

1. Shuttle the tape so that there is approximately the same amount of tape on each reel, and place the system in the stop mode.
2. Insert the tape tension meter in position A as shown in Figure B-2. Adjust R3 (Figure B-1)

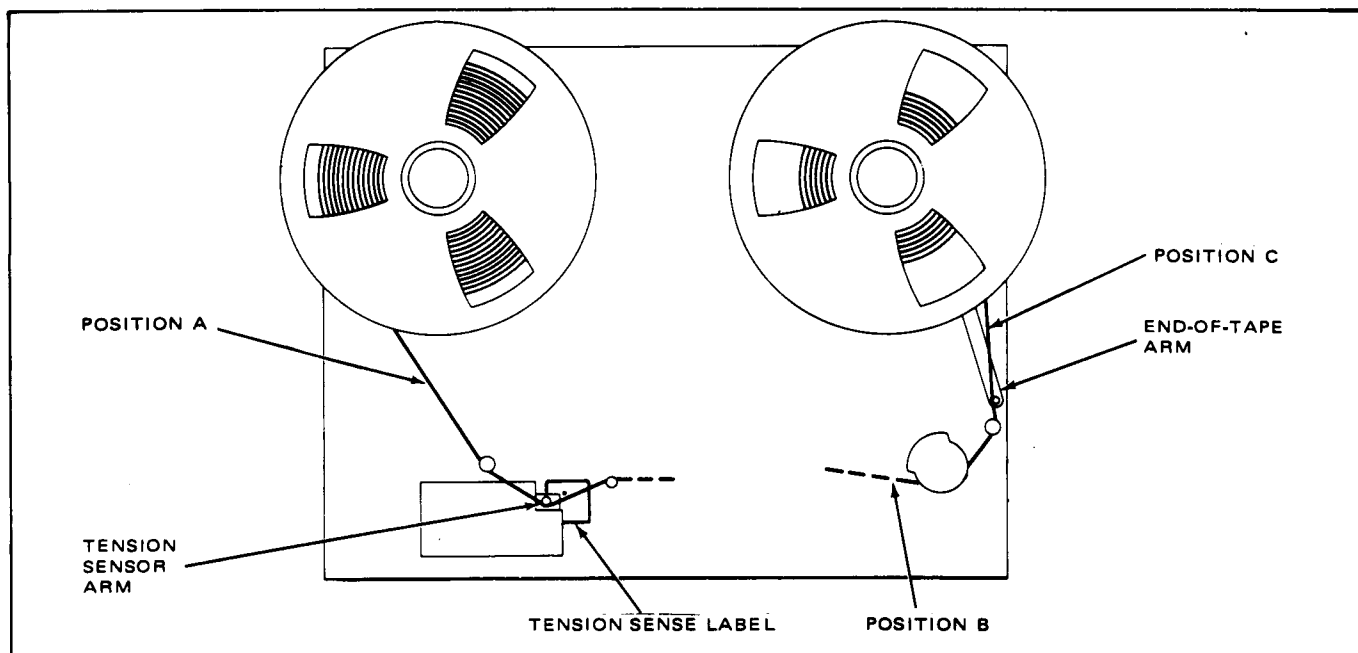

Figure B-2. Tape Tension Adjustments

- for a tension indication of 6.5 ± 0.5 oz (two-inch tape) or 3.5 ± 0.5 oz (one-inch tape).
3. Insert the tape tension meter in position C as shown in Figure B-2. Adjust R6 (Figure B-1) for a tension indication of 6.5 ± 0.5 oz (two-inch tape) or 3.5 ± 0.5 oz (one-inch tape).

NOTE

The above adjustments result in relatively high tape tension in the stop mode. If desired for easier tape handling and editing purposes, R3 and R6 (Figure B-1) may be adjusted so that the tension is approximately one-half of normal, or less, as indicated on the tape tension meter. Check that proper balance is maintained so that the tape does not tend to move in either direction during stop mode.

B-6. Play Tension – Not Using Tension Meter

Set the play tension as follows:

1. Push the end-of-tape arm toward the center of the transport, releasing reel tension and applying the reel motor brakes. Remove the tape from between the capstan shaft and the pinch roller and route tape around outside of capstan shaft. Then, take up the slack in the tape until the brakes release.

2. Depress the PLAY pushbutton while holding the takeup reel to prevent movement.
3. Adjust the play supply potentiometer R3 (for two-inch tape) or R10 (for one-inch tape) until the tension sensor arm aligns with the alignment mark for the appropriate tape size on the tension sense label under the tension sensor arm (Figure B-3).
4. Release the takeup reel and adjust play take-up potentiometer R5 until tensions are equal on both reels. This condition will exist when the tape shows no tendency to move in either direction.
5. Depress STOP pushbutton.
6. Rethread the tape normally and depress the PLAY pushbutton. The alignment surface of the tension sensor arm (Figure B-3) must be aligned with the center of the appropriate alignment mark on the tension sense label. Readjust potentiometer R2 (two-inch tape) or R10 (one-inch tape) as necessary to obtain correct alignment.

B-7. Play Tension – Using Tension Meter

If a tape tension meter, Tentel Model T2-H20-2 or equivalent, is available, the following procedure may be used to set play tension.

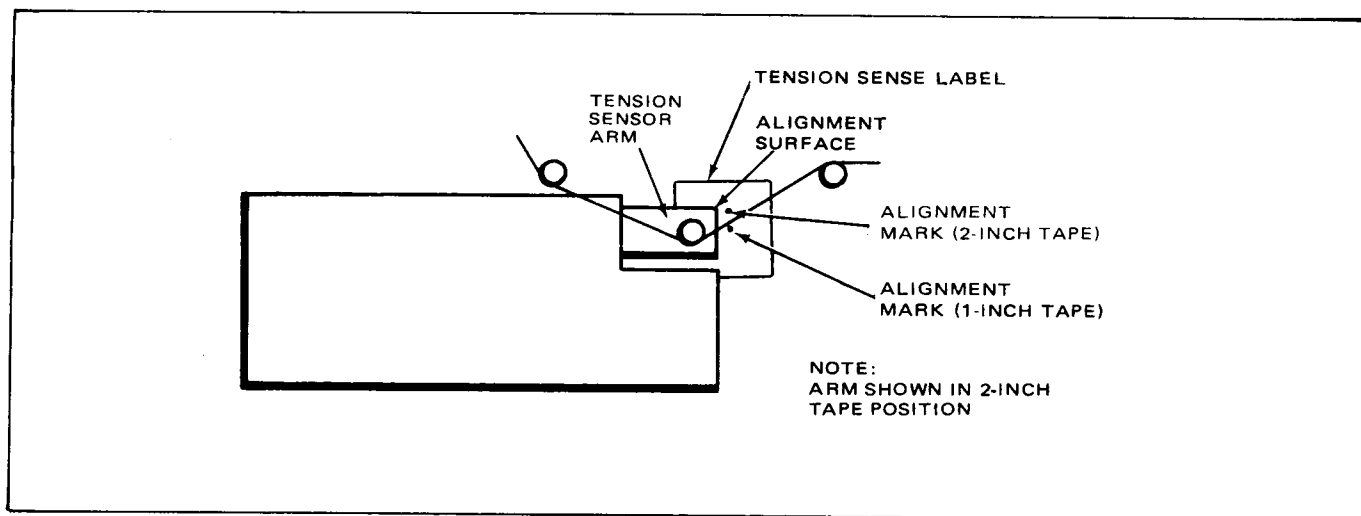

Figure B-3. Positioning Tension Sensor Arm

1. Shuttle the tape so that there is approximately the same amount of tape on each reel.
2. Insert the tension meter in position A as shown in Figure B-2, and depress the PLAY pushbutton. Adjust potentiometer R2 (two-inch tape) or R10 (one-inch tape) for a tension indication of 6.5 ± 0.5 oz (two inch tape) or 3.5 ± 0.5 oz (one-inch tape).
3. Insert the tension meter in position B as shown in Figure B-2. Adjust potentiometer R5 for a tension indication of 12 ± 1 oz (two-inch tape) or 6 ± 1 oz (one-inch tape).

B-8. Play Tension — Final Check and Adjustment

Perform the following procedure after setting play tension by either method above to verify correct operation.

1. Make a 90-second recording at 15 in/s using a 3-kHz test signal at normal operating level at the beginning of a reel.
2. Monitor the 3-kHz output of the channel just recorded. Depress the PLAY and STOP pushbuttons alternately. When the PLAY pushbutton is depressed, the reproduced signal should rise normally to the correct tone. If the play tension is too high, the tape may overspeed momentarily before settling to the correct tone.
3. Readjust potentiometer R5 as necessary to the point just below where overspeed occurs.

B-9. Shuttle Tension

Adjust the shuttle tension as follows:

1. Shuttle the tape so that approximately two-thirds of the tape is on the supply reel.
2. Depress the REWIND pushbutton. After the tape has accelerated to maximum speed, adjust rewind takeup potentiometer R4 such that the tension sensor arm (Figure B-3) aligns with the alignment mark on the tension sense label for the appropriate tape size.

3. Shuttle the tape so that two-thirds of the tape is on the takeup reel. Depress the FAST FWD pushbutton and adjust fast forward supply potentiometer R1 such that the tape accelerates at the desired rate.

NOTE

The shuttle tension settings outlined above result in optimum tape pack on a reel and maximum tape timer accuracy. However, for more rapid fast forward and rewind shuttling, potentiometers R4 and R5 may be adjusted for less hold-back tension as desired.

B-10. TENSION SENSOR ARM CALIBRATION

Check the tension sensor arm calibration as follows:

1. Remove power from the recorder/reproducer and remove tape from the area of the tension sensor arm.
2. Using a 30-ounce spring gauge, pull the tension sensor arm as shown in Figure B-4. The alignment surface of the tension sensor arm must align with the alignment marks on the tension sense label when the spring gauge indicates 4 ounces (one-inch tape) or 8 ounces (two-inch tape).

If the tensions specified in step 2 above, are not present, recalibrate the tension sensor arm as follows:

1. Remove the screw holding the tension sensor cover, remove the cover, and loosen the two screws that retain the tension sensor mounting block (see Figure B-4).
2. Reposition the mounting block such that the shutter opening is centered between the two photo cells with a tension of 8 ounces applied as shown in Figure B-4.

NOTE

The repositioning of the tension sensor arm may be most easily accomplished by

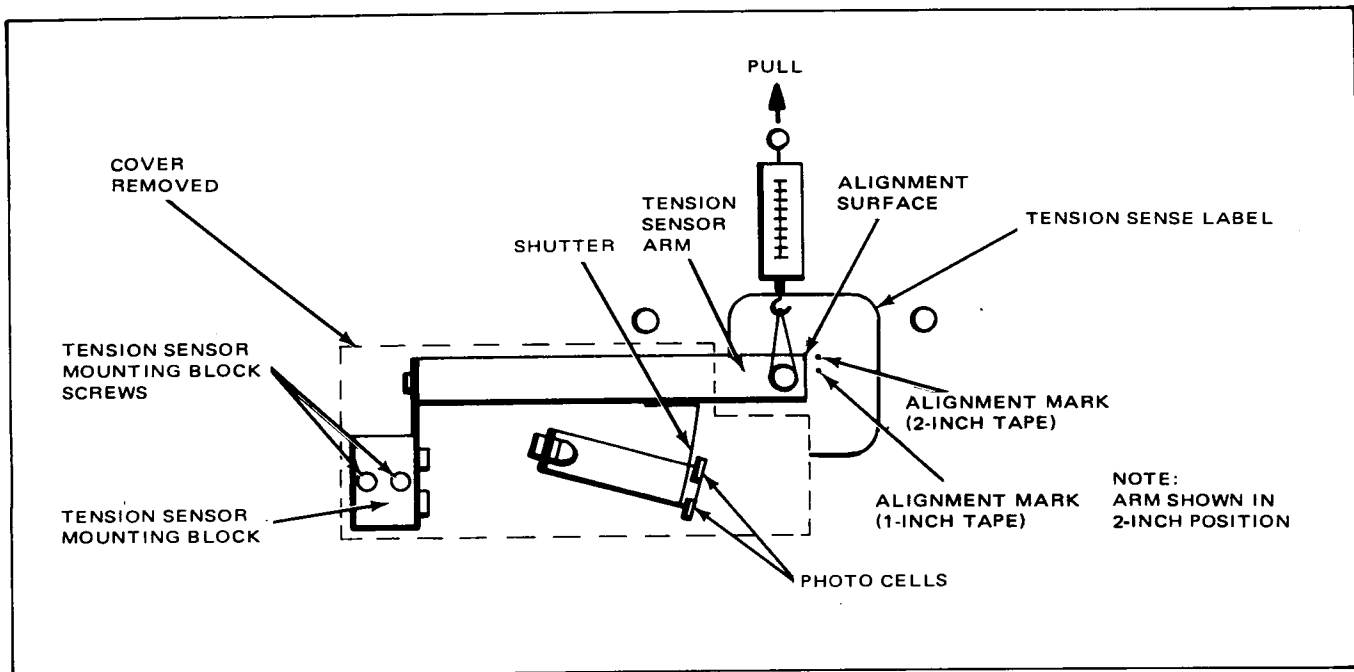

Figure B-4. Tension Sensor Arm Calibration

two persons; one to maintain 8 ounces of pressure on the tension sensor arm, and the other to readjust the mounting block.

3. When the correct position and tension have been achieved, tighten the two tension sensor mounting block screws.
4. Recheck the tension sensor arm calibration as outlined in steps 1 and 2 of the preceding paragraph and remark the tension sense label as necessary.

NOTE

The 4 and 8 ounce settings of the tension sensor arm correspond to 3-1/4 and 6-1/2 ounces of tape tension, respectively, at the supply reel.

5. Install the tension sensor cover and secure with one screw.

B-11. PARTS LIST AND SCHEMATIC

The parts list for the Transport Control PWA 4050706 and schematic 4840345 are included on the following pages.

| ITEM NO. | AMPEX PART NO. | REFERENCE NUMBER | DESCRIPTION | JEDEC NO. OR MFR. PART NO. |
|----------|----------------|--------------------|----------------------------------------------|----------------------------|
| | 4050706-07 | | TRANSPORT CONTROL PWA (NHA 4020403) | |
| 2 | 52528-01 | | HANDLE, SNAP ON | |
| 4 | 4840345 | | SCHEMATIC | |
| 5 | 013-983 | VR1 | DIODE | 1N752A |
| 7 | 014-247 | Q1-14,20,21 | TRANSISTOR | 2N2219 |
| 16 | 037-750 | C1 | CAPACITOR, TANT, 68 UF, 20V | |
| 17 | 041-336 | R12,13 | RESISTOR, COMP, 470 OHM, 1/2W, 5% | |
| 20 | 041-469 | R21 | RESISTOR, COMP, 330K, 1/4W, 5% | |
| 22 | 041-483 | R36,41 | RESISTOR, COMP, 27K, 1/4W, 5% | |
| 23 | 041-501 | R17 | RESISTOR, COMP, 330 OHM, 1W, 5% | |
| 24 | 041-561 | R16 | RESISTOR, COMP, 5.1K, 1/4W, 5% | |
| 26 | 041-772 | R23 | RESISTOR, COMP, 1.2M, 1/4W, 5% | |
| 31 | 058-602 | R5-8 | RESISTOR, VAR, 5K, 1W, 20% | |
| 32 | 058-662 | R1-4 | RESISTOR, VAR, 10K, 1W, 10% | |
| 33 | 058-855 | R9 | RESISTOR, VAR, 1.0M, 1/2W, 20% | |
| 35 | 280-998 | | PAD, MTG, XSTR, T0-5, REF: Q1-14,20,21,23,24 | |
| 36 | 580-464 | Q22,25 | TRANSISTOR | MJE1090 |
| 37 | 580-467 | Q15-19 | TRANSISTOR | MJE1100 |
| 38 | 586-268 | A11,12 | INTEGRATED CIRCUIT | UA741 |
| 39 | 587-103 | A4,5,13,16 | INTEGRATED CIRCUIT | MC680 |
| 40 | 587-101 | A2,9,14 | INTEGRATED CIRCUIT | MC661 |
| 41 | 587-102 | A1,3,6-8,10,15,17 | INTEGRATED CIRCUIT | MC668 |
| 42 | 586-795 | A18 | INTEGRATED CIRCUIT | MC665 |
| 43 | 041-396 | R29,30,46 | RESISTOR, COMP, 220 OHM, 1/4W, 5% | |
| 44 | 041-560 | R11,38,43,50 | RESISTOR, COMP, 2K, 1/4W, 5% | |
| 45 | 041-528 | R14,15 | RESISTOR, COMP, 300 OHM, 1/2W, 5% | |
| 46 | 041-408 | R19,39,44 | RESISTOR, COMP, 10K, 1/4W, 5% | |
| 48 | 041-413 | R37,42 | RESISTOR, COMP, 6.8K, 1/4W, 5% | |
| 50 | 014-678 | Q23,24 | TRANSISTOR | 2N3945 |
| 51 | 041-432 | R27,28 | RESISTOR, COMP, 220K, 1/4W, 5% | |
| 52 | 058-588 | R10 | RESISTOR, VAR, 1K, 1W, 10% | |
| 53 | 041-774 | R20 | RESISTOR, COMP, 1.5M, 1/4W, 5% | |
| 54 | 041-508 | R45 | RESISTOR, COMP, 20K, 1/4W, 5% | |
| 55 | 035-883 | C8 | CAPACITOR, MYLAR, 0.068 UF, 50V | |
| 56 | 056-163 | C7 | CAPACITOR, MICA, 470 PF, 500V, 5% | |
| 59 | 055-166 | C24 | CAPACITOR, MYLAR, 0.001 UF, 50V | |
| 63 | 013-599 | CR1-11,24-26 | DIODE | 1N914 |
| 64 | 014-698 | Q27 | TRANSISTOR | 2N3945 |
| 65 | 014-781 | Q26 | TRANSISTOR | MPS6518-5 |
| 66 | 030-057 | C2-6,9,11,20,26-28 | CAPACITOR, CER, 0.01 UF, 100V | |
| 67 | 034-153 | C10,13,14,18,21 | CAPACITOR, MICA, 1000 PF, 500V, 5% | |
| 68 | 037-790 | C19 | CAPACITOR, TANT, 2.2 UF, 20V, 20% | |
| 69 | 037-812 | C15,16 | CPACITOR, TANT, 10 UF, 25V, 20% | |
| 70 | 037-938 | C17,22,23,25 | CAPACITOR, TANT, 33 UF, 35V, 20% | |
| 72 | 041-409 | R24-26,31-34,47-49 | RESISTOR, COMP, 15K, 1/4W, 5% | |
| 74 | 041-518 | R22,51 | RESISTOR, COMP, 33K, 1/4W, 5% | |
| 75 | 037-899 | C29 | CAPACITOR, TANT, 0.1 UF, 35V, 20% | |
| 76 | 037-942 | C12 | CAPACITOR, TANT, 1.5 UF, 25V, 20% | |
| 77 | 013-650 | CR27-31 | DIODE | HPA-2970 |

N

SHEET 1 OF 1

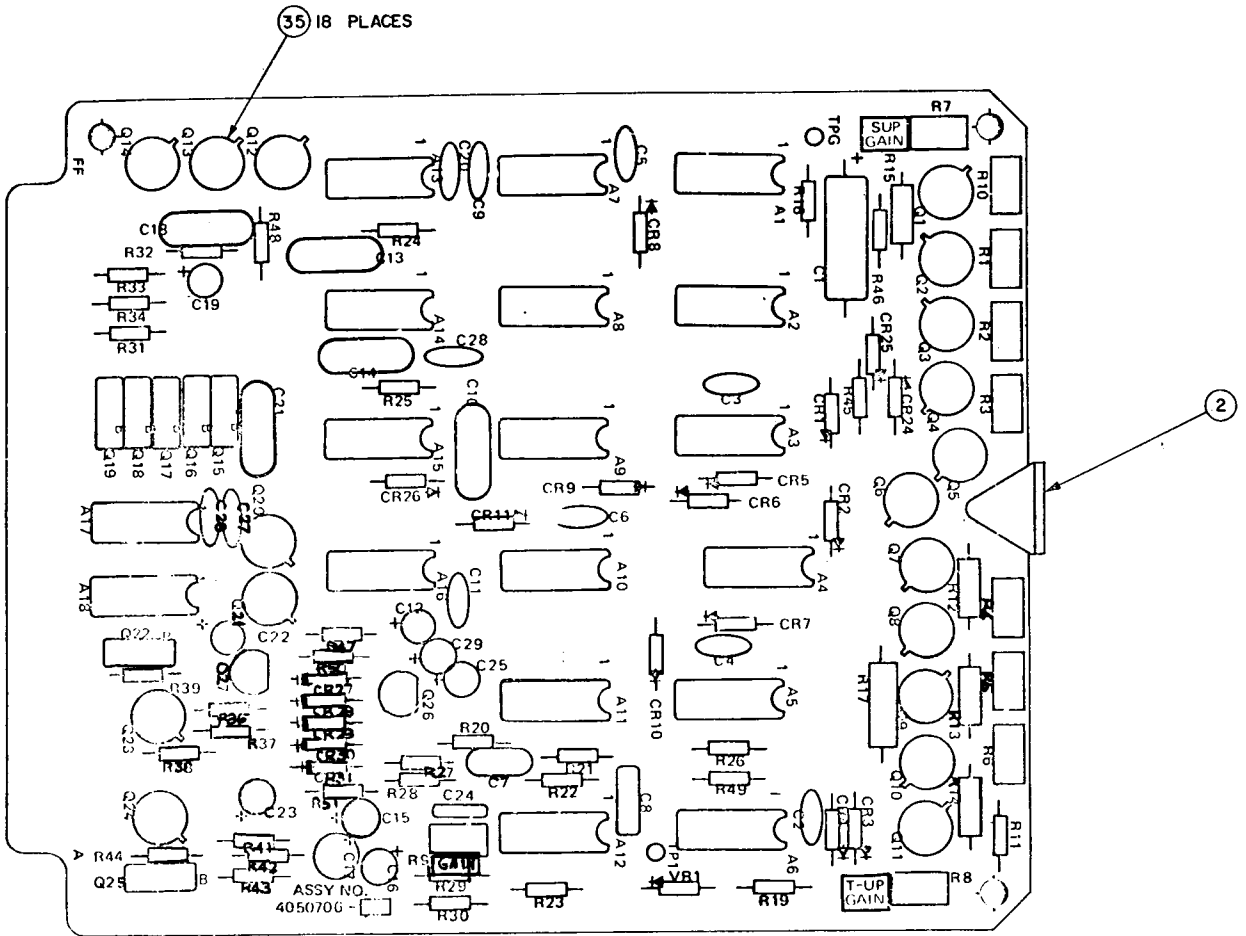

Assembly No. 4050706. Transport Control PWA

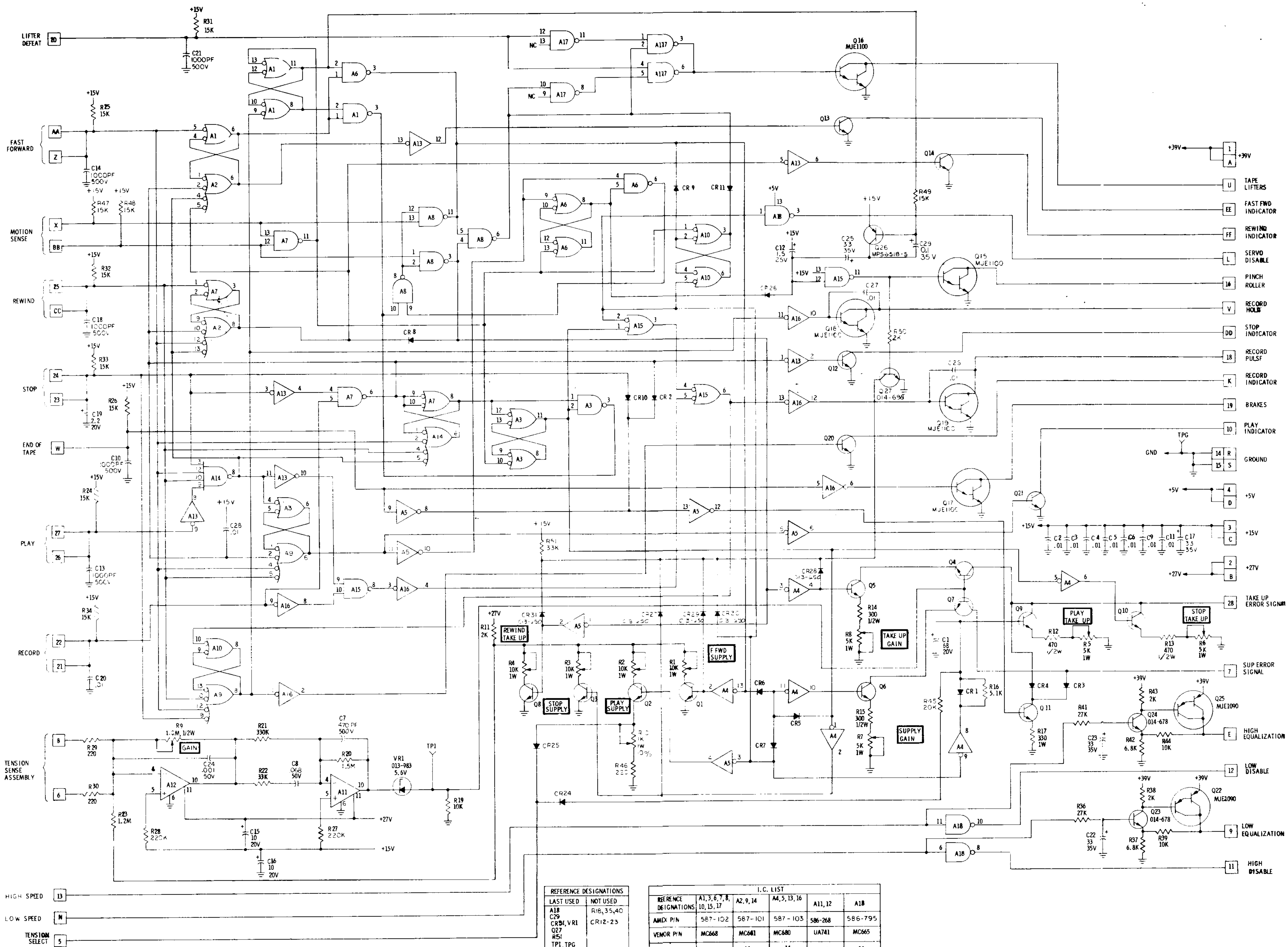

NOTES: UNLESS OTHERWISE SPECIFIED
 1. CAPACITANCE VALUES ARE IN MICROFARADS, 100V
 2. DIODES ARE PART NO. 013-599 FOR FIELD SERVICE SUBSTITUTE 1N94. 3. TRANSISTORS ARE PART NO. 014-247, FOR FIELD SERVICE SUBSTITUTE 2N2219.
 4. RESISTANCE VALUES ARE IN OHMS, 1/4W, 5%.

REFERENCE DESIGNATIONS

| LAST USED | NOT USED |
|------------|-------------|
| A18 | R16, 35, 40 |
| C29 | CR12-23 |
| CR24, V R1 | |
| Q27 | |
| RS1 | |
| TP1, TPG | |

I.C. LIST

| REFERENCE DESIGNATIONS | A1, 3, 6, 7, 8, 10, 15, 17 | A2, 9, 14 | A4, 5, 13, 16 | A11, 12 | A18 |
|------------------------|----------------------------|-----------|---------------|---------|---------|
| AMIX P/N | 587-102 | 587-101 | 587-103 | 586-268 | 586-795 |
| VENDOR P/N | MC668 | MC681 | MC680 | UA741 | MC665 |
| VOLTAGE (P/N) | 14 | 14 | 14 | 11 | 14 |
| GROUND (P/N) | 7 | 7 | 7 | 6 | 7 |

TABLE I
 P.W. 4551
 4050706-06
 4050706-07

SCHEMATIC ISSUE
 15504 "F"
 ISSUE "G"

Schematic No. 4840345K.
 Transport Control PWA

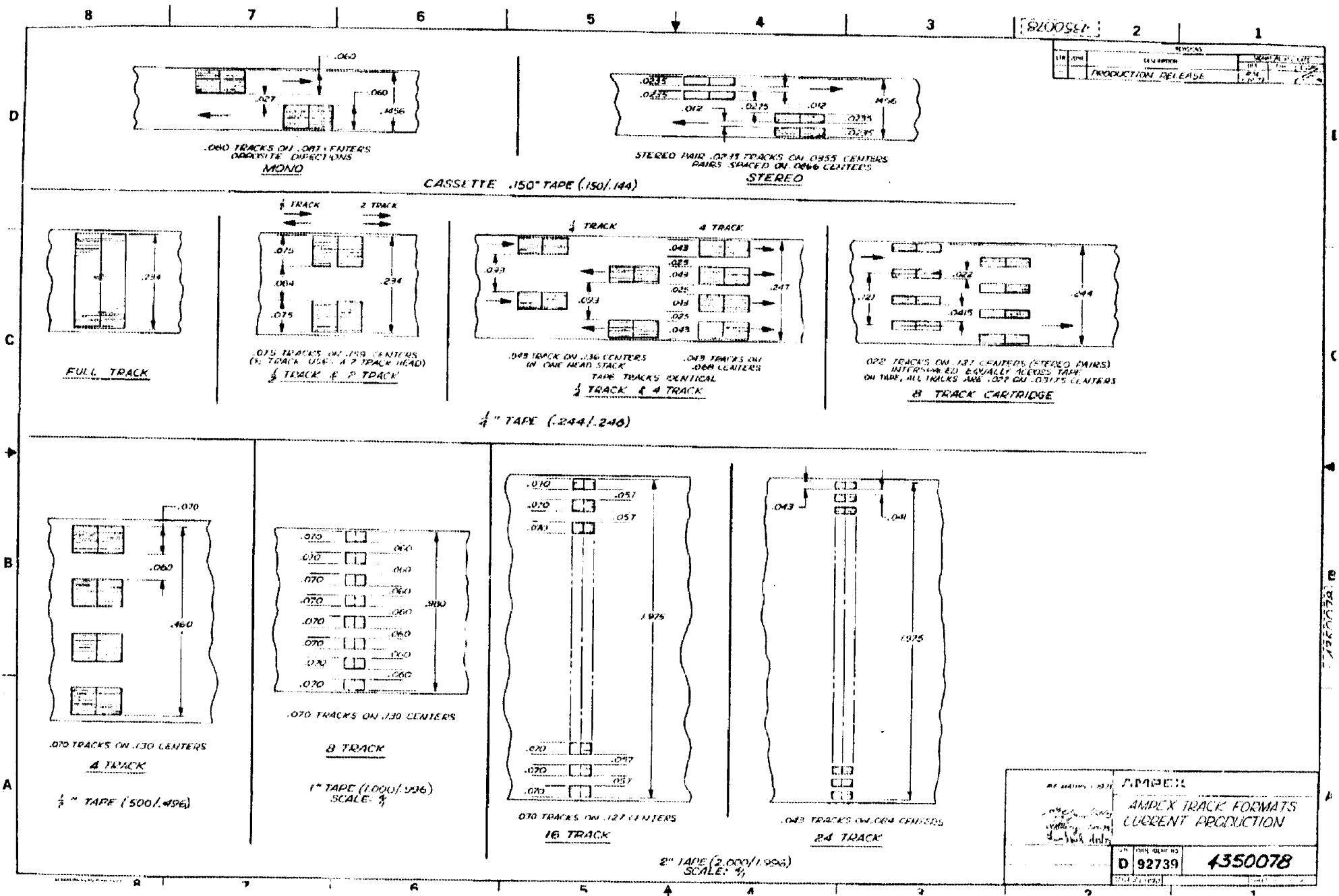

This Manual or Schematic is a

FREE DOWNLOAD

For everyone...

From the archives of

Analogrules.com

and

AudioSchematics.com

**If you have paid anything for this
Manual or Schematic**

You have been

RIPPED OFF

**Demand your money back
And let us know who is stealing
our files and charging for
our free downloads**

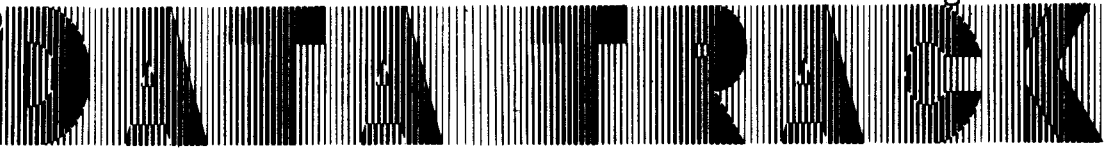

Dedicated To Excellence Through Innovation · Education · Communication

SPARS NEW YORK REGIONAL MEETING

PART I

3/19/81

REVIEW : "PROBLEMS AND SOLUTIONS / AMPEX 1200"
SPEAKER: MICHAEL GUTHRIE, DIRECTOR OF ENGINEERING
RECORD PLANT STUDIOS, LTD. -NYC

Dear MM-1200 User:

The following package of information has been compiled by the Maintenance staff of Record Plant Studios to aid the users of this machine.

It contains solutions to common problems with this machine. It is not a cure-all, and it is not a substitute for good maintenance, or for knowing what you are doing. All of the changes indicated have been made in many machines, and in our experience are reliable. We cannot, however, be responsible for these or any other changes you make in your machine. We especially recommend that you advise Ampex of all problems, and possible modifications during the warantee period.

We would like to thank the many people who have contributed ideas to this list. I am especially grateful to Bob Michaud, and Ben Oniki at Ampex for the help they have given us over the years, and would note that they contributed many of the changes. Good luck.

Good luck.

Michael Guthrie
Director of Engineering
Record Plant Studios, Ltd. (NYC)

Record Plant Studios MM-1200 modification procedures:

- 1) Add tension bulb indicator. Failure of the tension bulb during a session can cause huge client problems if it is not noted BEFORE the most important take of the day. The machine still runs, but with improper tensions.

Drill a 3/16" hole in the indicated position on the tension sense cover, and glue a small red lense on the inside. reinstall on machine. Inform all operators not to operate machine without lit indicator.

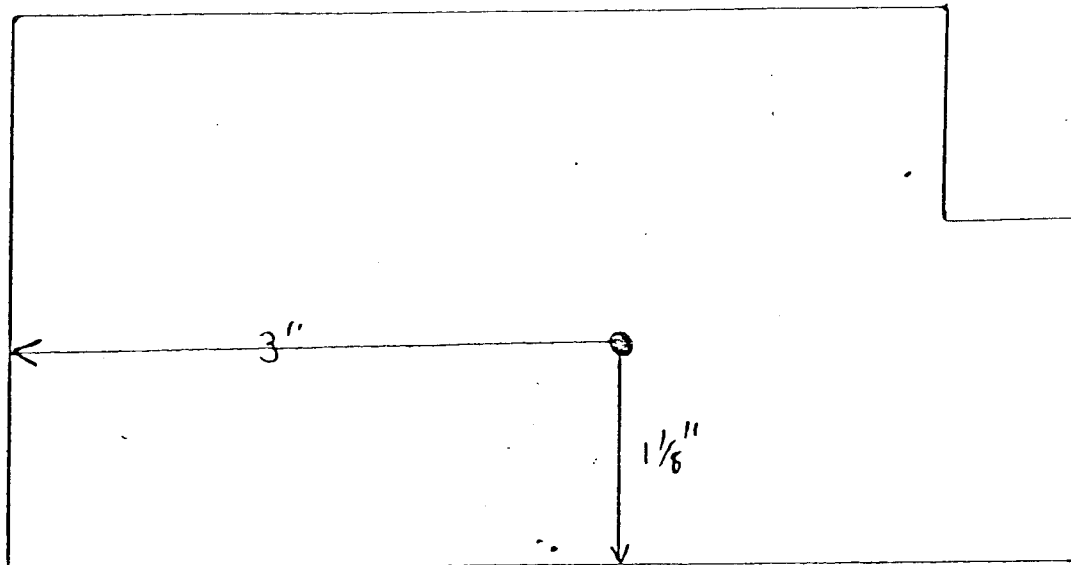

- 2) Check C-22 on the Capstan servo card. It must be 3300 pF. If not, change it. Erratic servo lock results on 80% of the machines with the original cap.
- 3) Check for improper fuse size, and especially slo-blow fuses in the 39 and 27 volt power supplies. Slo-blow fuses cause failure of the crowbar in event of over voltage condition.
- 4) Modify the controll box as follows:
Add a 270 ohm 1W resistor in series with R1,3,6,8,9.
Add a 3ohm 2W resistor in parallel with R13,14 on the standby switcher card
Add an 1N4001 in series with the lead to point E4 on the main board, coming from E4 on the LED board. The banded end faces the main board.
Change R41,42,44,45,38 to 680 1/2W.

these changes increase the lamp life and cool the controll buttons, prevent logic latchup, prevent LED ghosting, and improve controll switch life respectively.

- 5) Any machine used in a high RF field (all of NYC) should have a 1 uH choke placed in series with the base of Q1 on each Reproduce PWA. This is especially effective against TV interference common in New York.
- 6) The upper right corner of the reproduce head shield should be rounded off with a file to prevent tape damage when unthreading the machine to edit. To do this, remove the head assembly from the machine. Remove the head shield from the assembly, and carefully, with a small file remove the sharp corner from the shield. [A FREE download from the Archives at AnalogRules.com](http://www.AnalogRules.com) it easy to get

- (6) the tape between the shield and the tape guide without the danger of edge damage.
- 7) While the head assembly is off the machine, check the female head connectors on the machine for damage, and that they are regularly spaced on the top plate. They are able to move quite a bit when loosened. Check the male connectors on the head assembly for damage, and check that the nuts which attach them are tightened enough to engage the nylon in the small NYLOCK nut. on most of these, there is not enough length in the hardware to accomplish this and still maintain slop for self alignment. In this case, substitute an ordinary nut, and lock it in place with a little locktight. Head assemblies which have had the web destroyed by tightening the assembly down with improper alignment of the connectors can be saved by removing the nuts on top of the connectors. removing the broken section of web, or bending it back in place, and substituting a thin piece of threaded aluminium going across all the connectors for the nuts. The assembly then goes back together with plain nuts and locktite.
- 8) Machine side panels should have a piece of very heavy neoprene rubber or foam glued into the space between the mounting channels to prevent rattles, and to damp the resonance of the panel if the machine is to be used in the audio monitoring field. This also reduces fan noise.
- 9) If the machine is to be used in a room which has 110V VSO's for 440 machines the VSO socket should be changed to a 6 pin. plugging a 110V VSO into this socket will produce spectacular results.
- 10) Either a narrow pinch wheel, or an Ampex tension Kit should be installed on all machines. All machines not so equipped will run between .5 and 1.5% slow at the end of a 10.5" reel after 1000 or so hours of operation, the exact figures depend on many factors, including tape type, amount of stopping and starting etc. The problem is much worse with 14" reels, and with increasing wear on the capstan shaft. the narrow pinch wheel could be of the MM-1000 type, the type used on the 2" VTR, or a regular assembly with the material cut back leaving rubber only where the tape will be (allow about a sixteenth on either side for mechanical and guidance tolerance) ie leave 1 7/8 inches of material in the center of the pinch wheel. United Research 16 E 52 d St. NYC NY can supply pinch wheels to this spec resurfaced with ML6 material on old pinch wheels. These have not been tested, however, cut neoprene pinch wheels made to these dimensions have, and work quite well. Machines with either the pinch wheel change or the tension kit will maintain speed spec from end to end of a 16" reel.
- 11) When installing the tension controller kit, the following changes have been found to be beneficial. Complete instructions follow. The two 1N34 diodes and the 1N5256 make the stop and RW tensions independent of the play tension. This also leaves the pots which set these tensions closer to their centers. The regulator shown reduces the tension change with change in the 27 V power supply. This reduces drift, and allows repairs and adjustments of the 27 V supply without tension readjustment.
- 12) The powersupply modification which follows reduces the hum and low freq. garbage present in the output of the machine. These noises are below the noise of an individual channel, but when 24 tracks are summed in phase in a mix situation they become the SN limit of the machine. Note that this mod would probably

(12) not be necessary if the 39 V common in the power supply were lifted from ground and the ground connections of C28,30 and R49,53 on the transport control PWA were taken to transport connector J5, pin 5. This would prevent noise on the 27 V common line from entering the EQ lines. Also note that it is advisable to add a 1N5298 constant current diode from each EQ line to ground. This bleeds away current when the line is low, bringing it below the turn on voltage of the diodes in the Reproduce amplifiers. About 1 or 2 % of these diodes are very noisy when slightly on as when these constant current diodes are not in the machine. A more effective way would be to add a transistor to pull the line low when not in use.

The MPS-U56 circuit is not necessary, but will pay for itself in meter lamps in less than a year. Note that it will also save your ears and monitor speakers if someone forgets to mute them when switching on the machine. The time up can be raised or lowered by scaling the 22K resistor. It is about 3 sec with the values shown. Note also that this mod reduces power supply noise slightly.

13) MDA mods.

- 1) install SET 31307 transistors in Q101,102,105,106. Add the 220 ohm resistors, and the diodes as shown in the tension kit instructions. Note the 013-678 can be replaced with a 1n4004 etc. if you're not an Ampex dealer.
- 2) add two fuse holders to the PWA panel as shown. cut the lands leading to the Q1,7 collectors between C2,9 and the transistors. Drill two holes to pick up these lands on each side and wire to the fuse holders. install 1/4 or 3/8 A sol blow fuses in the fuse holders. These fuses will, at least in most cases, protect Q1,7 from failure when the transistors on the heatsink assembly fail.
- 3) if installing a tension kit, follow the instructions concerning further mods that go with that kit. Do not do these unless you are installing the kit.
- 4) Make two duct plates as shown in the drawing. these should be black anodise aluminium if possible or painted flat black if not. Drill and tap four holes for 6-32 screws in each heat sink, and use 6-32 X 1 1/4" screws, lock washers, and flat washers to attach the duct plates to the heat sinks.
- 5) Remove the fan, and turn it around when reinstalling it. it will now blow out. Do not install a filter in this location.

Power Supply Modification Procedure

Purpose:

Ground loops in machine wiring introduce noise from motors and controll logic into reproduce preamps via EQ switch lines. Modification removes these interactions and provides improved signal to noise ratio.

- 1) remove powersupply assembly from machine and remove top and heat sink assembly
- 2) remove jumper connecting C2 neg to chasis
- 3) remove jumper connecting C4 Neg to C5 Neg.
- 4) remove jumper connecting pins 6 and 8 on J1
- 5) remove jumper connection between pin 1 and pins 4,7,10 on J2.
- 6) remove jumper connecting pin 11 and pins 2,5,8 on J2
- 7) add a 16 ga wire from 2,5,8 of J2 to TS2 pin 5 (on heatsink ass), leave existing yellow wire on pin 11 (J2) and existing grey on 2,5,8 (J2).
- 8) add a 16 ga wire from 4,7,10 of J2 to C2 Neg. Leave the existing black wire on pin 1 (J2).
- 9) add a 16 ga wire from C7 Neg (E4) to the heatsink assembly near A4, and connect a 4.7mf 10 v or greater Tant. between A4 input and the added ground wire. the cap can be added to a small terminal strip added a few inches from A4. The input of A4 is the pin that would be the base of a To-3 transistor.
- 10) remove C3 from TS3. near TS3, mount a small turet board with the following on it.

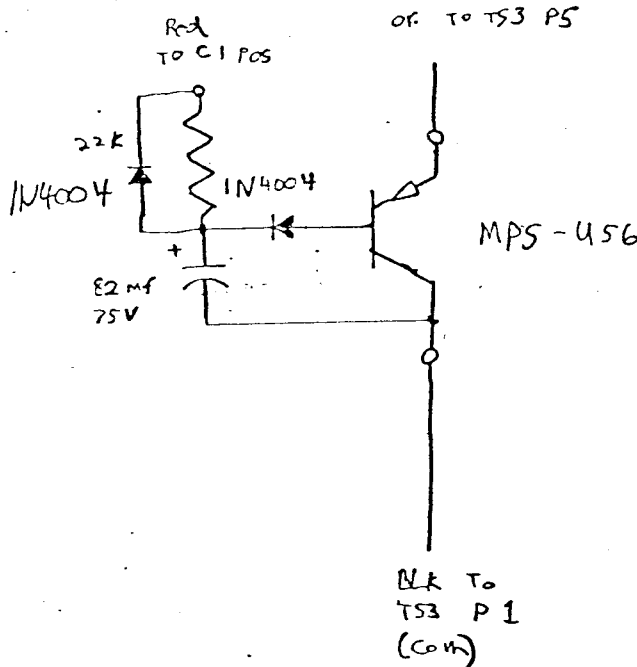

- 11) the MPS-U56 collector connects where C3 neg was. the emitter connects where C3 pos was, and the resistor gets a new wire back to C1 pos.
- 12) solder all ring lugs, both new and existing, and add a lockwasher between the lowest lug and the cap on C1,C2,C4,C5. Neatly tie all new wiring, and reassemble the power supply.
- 13) add an 18 ga wire from Transport Connector J5 (burndy) ^{pin 5} to transport control chassis J1 pin 15.
- 14) reassemble machine, check audio noise with notape, in play, with the head gate closed. reset tensions and power supply voltages if necessary and check for proper operation of all functions.

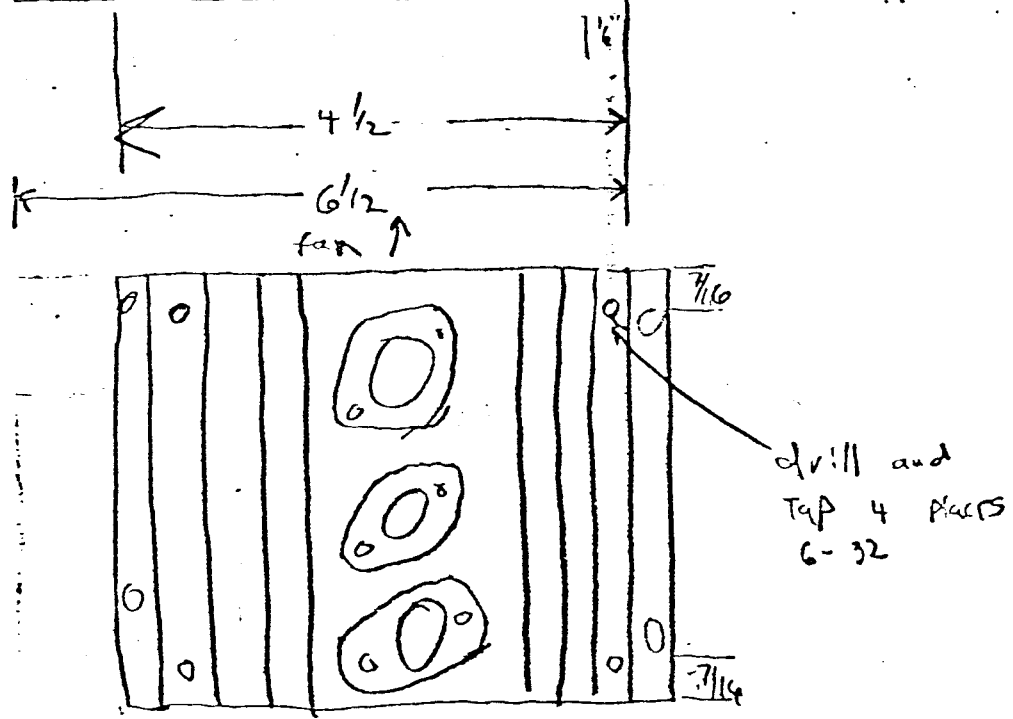
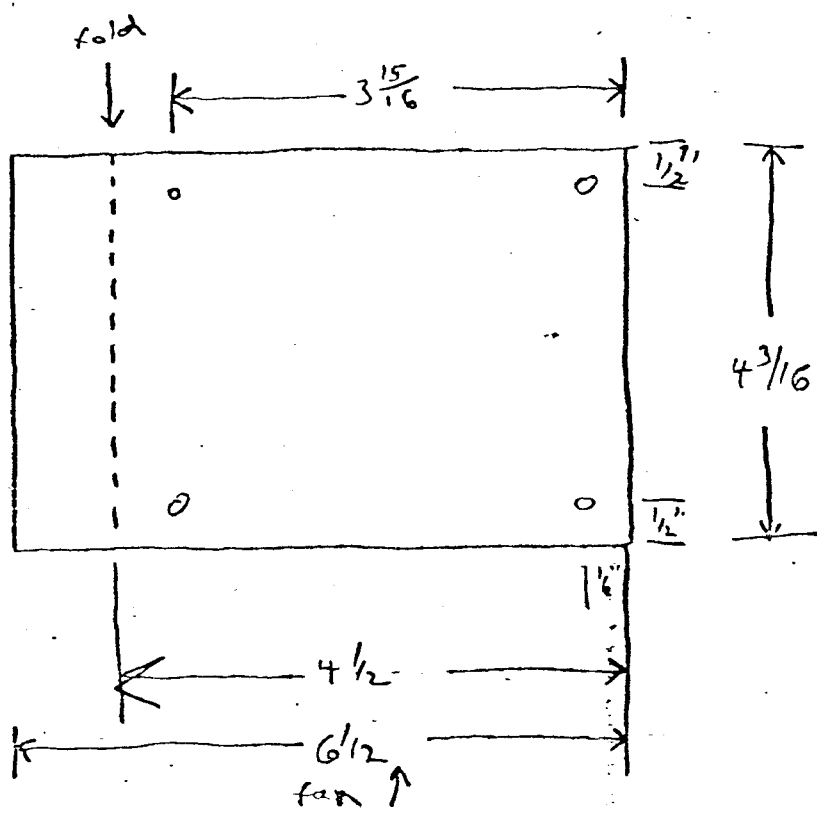
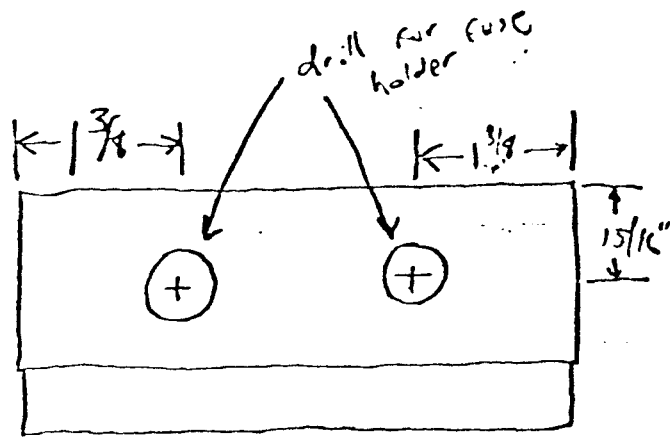

- 14) Here are two unnecessary, but nice additions for the MM-1200. the first is a piggy back board for the capstan servo card, which indicates the presence of bad bearings, servo oscillations, heavy corrections from synchronisers etc which might cause flutter. It is quite sensitive, with a little practice, you can learn to identify flutter below .07%, before it becomes a problem.

MM-1200 flutter indicator mod m-6. - 10/11

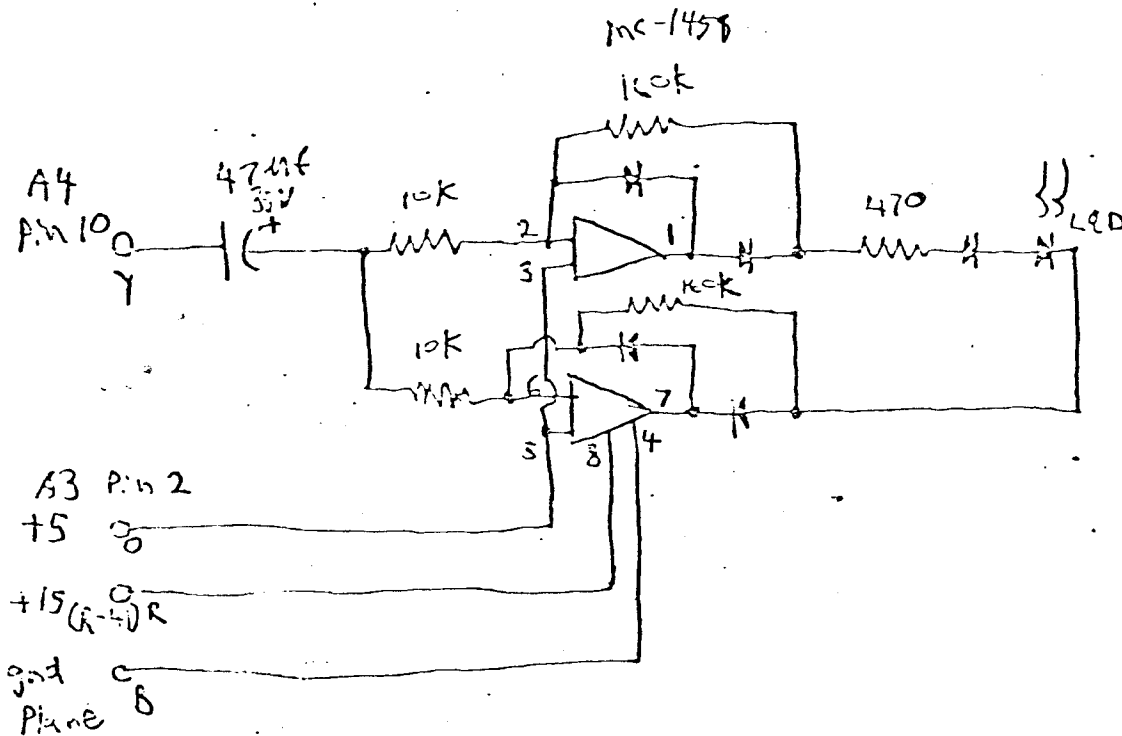

All # IN914

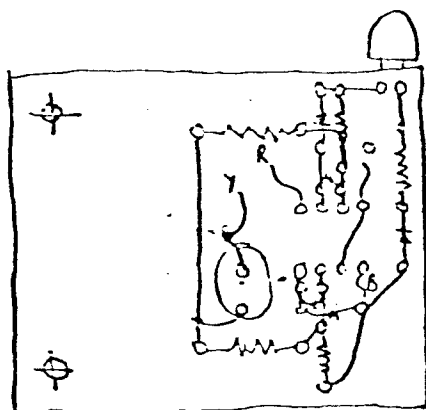

This one is a meter buffer amplifier that will eliminate the distortion caused by the VU meters. This distortion can, under some conditions, be as great as the distortion from the tape. also on this card is a meter lamp buffer that dims the lamps in play, and brightens them in record, giving record indication on the front of the machine. the amplifier does not affect bias metering as an op-amp might, and does not affect the common mode floating of the output transformer.

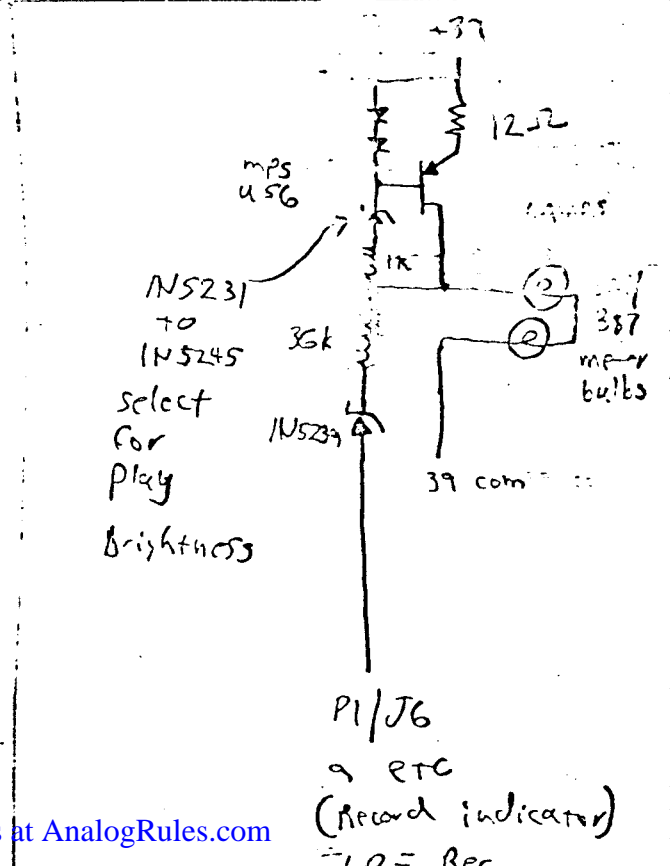
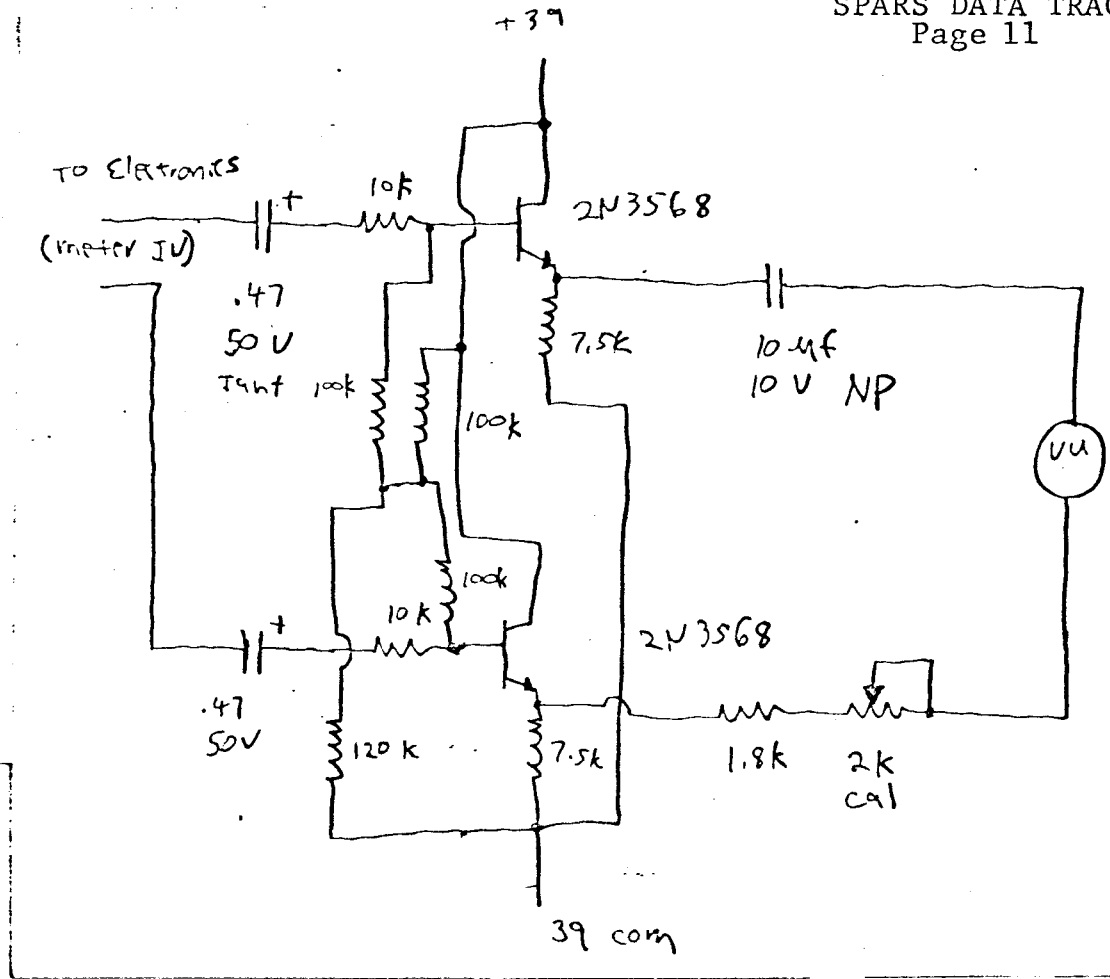

CHANGES AND ADDITIONS TO TAKEUP TENSION CONTROLLER KIT * Record Plant Studios
2/16/81

Page 1

Do not install R 29, but rather install a wire to go to new regulator board. This wire goes in the hole connected to A2 pin 5. (this eyelet is near A2 P1)

Do not install R 24, install a wire here also. the eyelet which connects to A2 P4, near A2 p1

Build the aux 24V regulator shown below, and install on card.

Be sure the MDA has SDT31307 transistors on heatsink, and add the diode to the collectors of Q6 and Q3.

Be sure the fuses on the rear panel are wired, and that 3/8 A MDL fuses are installed.

Complete the piggyback on Capstan Servo PWA as instructed.

Page 1A

Note changes in takeup MDA, and regulator addition shown below

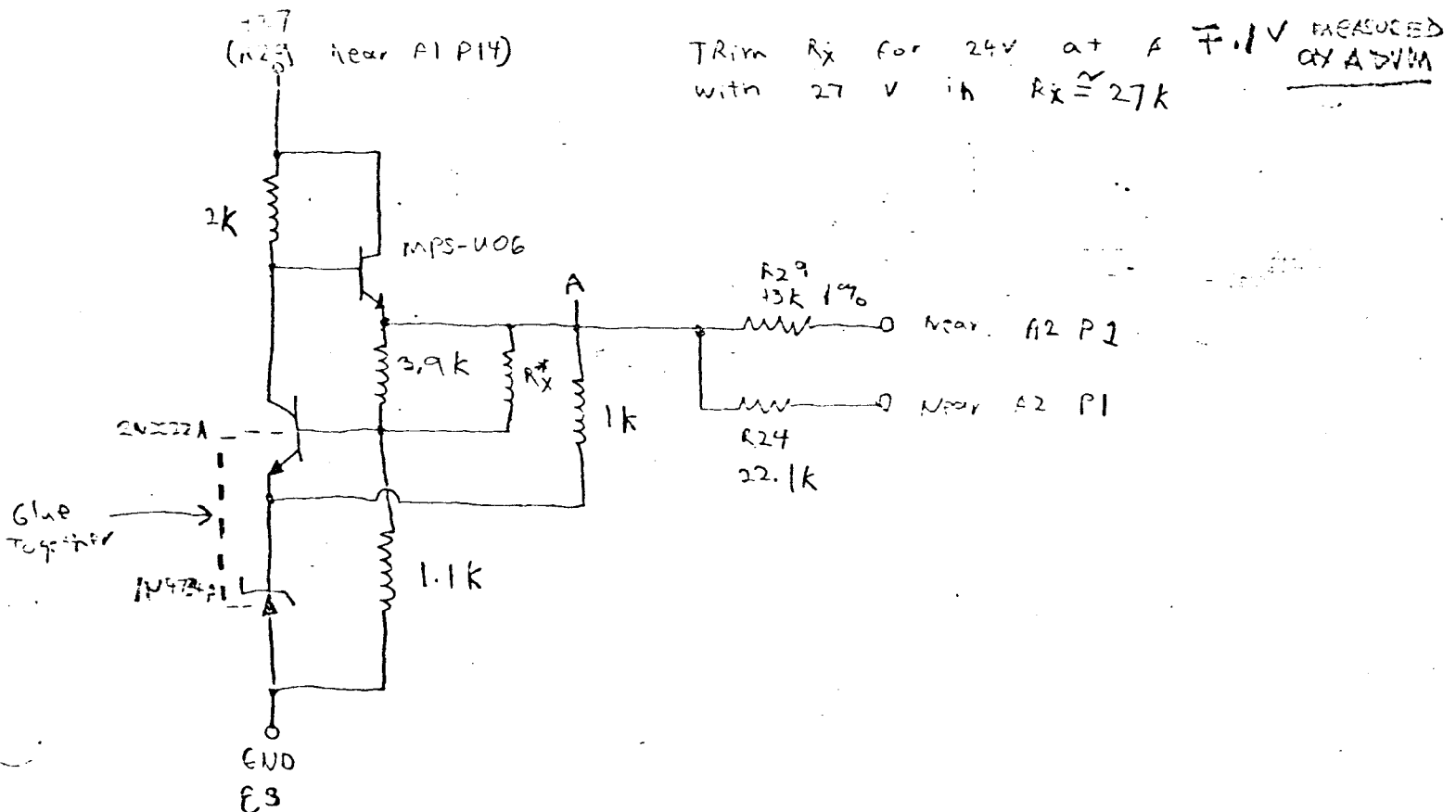

Page 2

Note dimension change on hole location. This prevents interference between meter wiring and Tensioncontroller PWA.

Page 3

Note change in location of the Motor Control Indicator, because of Power supply indicators now on top of spacer.

note also that VR1 on Indicator board must be changed as per schematic Page 6A

Page 6

Before completing installation as per page 6, modify the Tension Controller PWA as following; (note changes on schematic, Page 6A)

Add two 1N34 diodes from the bases of Q19, Q20 respectively to the Servo Disable line U10 p13. use tubing on the leads, and place them on the top side of the board

add a 1N5256B zener across c12. the banded end goes to the side connecting to U1 p2. Place this diode on the back side of the board, under C12.

SETTING TENSIONS

after checking operation of unit as per page 6, set tensions as follows

- 1) place transport control PWA on extender. turn machine on, and block the tape break arm in on position. turn machine on.
- 2) turn FF and RW tensions all the way down (four turns CCW)
- 3) place machine in RW, and adjust the TU gain until the motor just ceases turning
- 4) place the machine in FF, and similarly adjust the Supply Gain.
- 5) thread tape. put the machine in FF, and adjust FF supply tension so that after acceleration, the tension stabilizes just short of the 2" mark on the tension arm.
- 6) put the machine in RW, and adjust RW tensions the same.
- 7) go to the head of the reel, place the machine in play, and adjust R60 on the Tension Controller PWA for 16 oz of takeup tension. Adjust supply tension for 5½ oz.
- 8) go to the center of the reel (10½" or a quarter of the way 14") and check tensions. supply should be 6+-1 oz. Takeup should be 16 oz +- 1.5 oz
- 9) go to the end of the reel (10½" or about 2/3 of 14") and check tensions again. same numbers

- 10) on larger reels (14,16") the supply tension should be able to maintain 6 ± 1 oz, anywhere in reel. The takeup should be able to maintain 16 ± 1 to the end of a $10\frac{1}{2}$ ", and nearly to the end of a 14". Beyond the end of a 14, tension will fall off due to lack of torque in takeup motor.
- 11) in case of problems, check the voltage at TP1 on tension controller PWA if takeup isn't right, or at pin 7 on the transport controller PWA in the case of the supply.
- 12) TP1 should be $30 \pm 2V$ in all wind and stop modes, below 10v with no tape up, and should be variable by R60 from about 3 to 30 v. in play. (reel motor stopped). With reel motor turning, the voltage should drop as the motor spins faster.

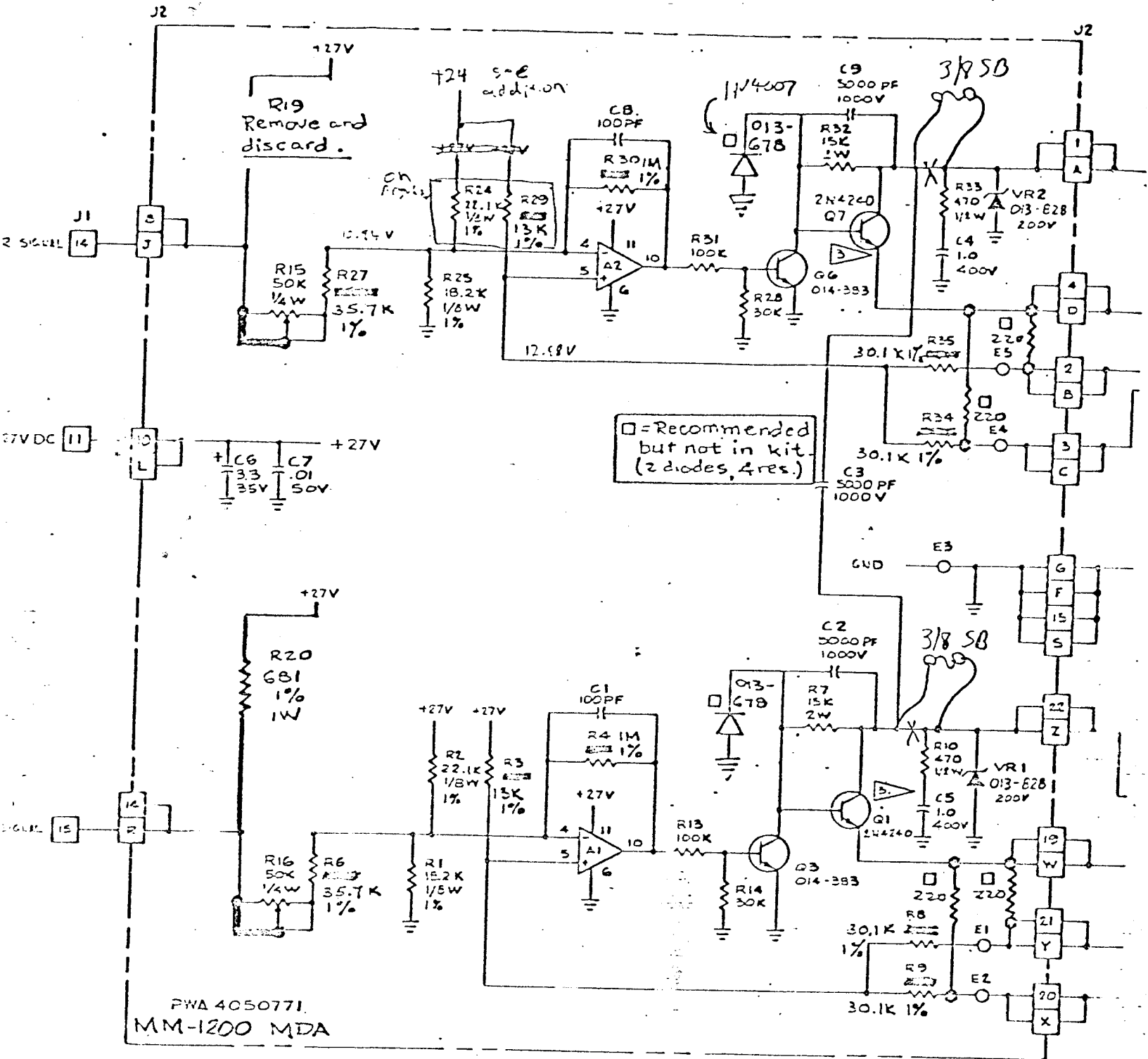

OTHERWISE SPECIFIED
RESISTOR VALUES ARE IN OHMS, 1/4W, 5%
CAPACITOR VALUES ARE IN MICROFARADS
RESISTOR VALUES ARE IN OHMS, 1/4W, 5%
CAPACITOR VALUES ARE IN MICROFARADS

| FIELD SERVICE SUBSTITUTION | |
|----------------------------|-------------------------------|
| AMPEX P/N | NEAREST COMMERCIAL EQUIVALENT |
| 014-353 | 2N2484 |
| 014-832 | MPS3638A |
| 580-729 | 2N5239 |
| 580-258 | UA741 (54774-353) |

| REFERENCE DESIGNATION | |
|-----------------------|----------|
| LIST USED | NOT USED |
| R35 | R17, R23 |
| C9 | |
| Q7 | |
| E2 | C4 |
| VR2 | |
| A2 | |

3.0 TRANSPORT CONTROL PWR; PART NO. 4050706; MODIFICATION:

3.1 REMOVE AND DISCARD R18 AND 20.

SPARS DATA TRACK

Page 16

ENC: MODIFIED TRANSPORT CONTROL SCHEMATIC

4.0 INSTALLATION OF THE TENSION CONTROLLER PWR BRACKET:

4.1 PULL OUT THE ARMREST AND METER PANEL AS FAR AS THE SLOTS IN THE ADJUSTABLE SIDE-ARMS WILL ALLOW.

4.2 REMOVE THE TRANSPORT CONTROL BOX.

4.3 REMOVE THE SHELF THAT SUPPORTS THE TRANSPORT CONTROL BOX.

4.4 REMOVE THE BLACK SPACER PIECE THAT IS LOCATED BETWEEN THE TRANSPORT CONTROL CHASSIS AND THE TRANSPORT CONTROL BOX. A NO. 2 PHILLIPS SCREWDRIVER IS NECESSARY TO REMOVE THE MOUNTING SCREWS.

4.5 DRILL TWO HOLES 0.2 INCHES IN DIA. ON A LINE 0.62 INCHES FROM THE FRONT EDGE OF THE SHELF. THE HOLES ARE 5.2 INCHES APART AND THE FIRST HOLE IS 2.5 INCHES FROM THE LEFT EDGE OF THE SHELF.

4.6 MOUNT TENSION CONTROLLER MOUNTING BRACKET WITH TWO NO. 8-32 SCREWS AND FLAT WASHERS SO THAT IT EXTENDS DOWNWARD FROM THE SHELF WHEN THE SHELF IS IN ITS NORMAL POSITION. THE SLOTS FOR THE PWR EDGE CONNECTOR SHOULD BE TO THE LEFT. SET ASIDE THE RESULTING ASSEMBLY UNTIL A LATER STEP.

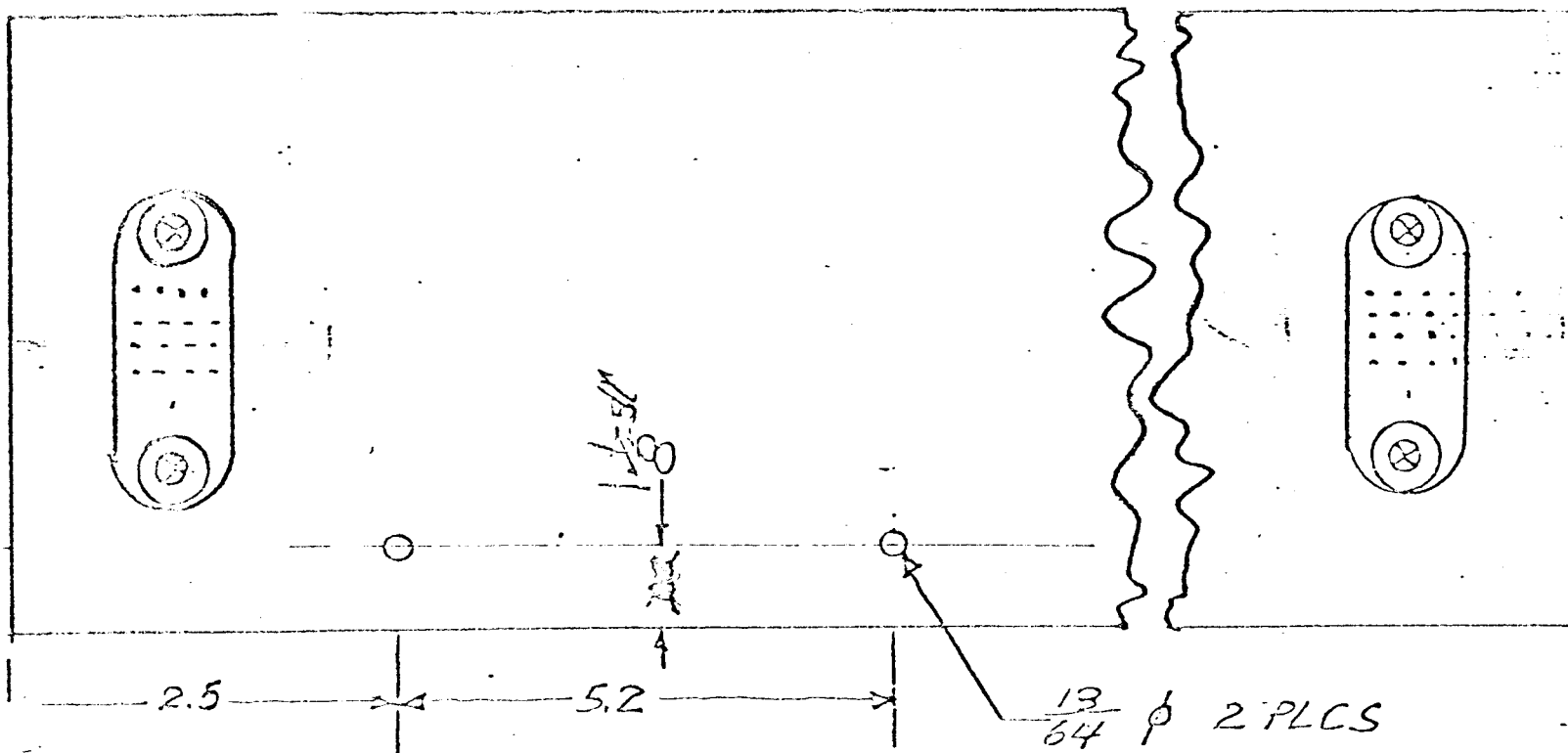

TRANSPORT CONTROL BOX SUPPORT SHELF
NEW HOLES LAYOUT

This Manual or Schematic is a

FREE DOWNLOAD

For everyone...

From the archives of

Analogrules.com

and

AudioSchematics.com

**If you have paid anything for this
Manual or Schematic**

You have been

RIPPED OFF

**Demand your money back
And let us know who is stealing
our files and charging for
our free downloads**

TITLE: MM-1200 SEARCH TO CUE MULTIPLEX "BEAT"

I. APPLICABILITY

All MM-1200's from Serial No. 1001 to 1075

II. PURPOSE

To eliminate a very low level beat frequency recorded on tape in the 100 HZ to 5 KHZ region.

III. DISCUSSION

The Search to Cue multiplex beat problem is caused by the beating of the 9th harmonic of the digit frequency (approximately 297 KHZ) with the second harmonic of the bias frequency (300 KHZ) or approximately 3 KHZ. Due to temperature changes causing drift in the digit frequency, the beat frequency may vary from 100 HZ to 5 KHZ. This may or may not be present on all machines Serial No. 1001 to 1075.

IV. PARTS NEEDED

1 each - 68 MF capacitor, tantalum, 15V, 20%.
Ampex P/N 037-957

7 each - 120 OHM Resistors, Comp., 1/4W, 10%.
Ampex P/N 049-545

V. PROCEDURE

This is a two step procedure.

Step 1. Remove AC power from the line. Remove the D.C. power supply cover and both regulator cards. Locate the rear of J1, a ten pin Jones connector. Cut the bare wire from J1, Pins 6 and 8. Re-install both regulator cards and the cover.

Step 2. Remove the Search to Cue tape timer assembly P/N 4020414-XX and locate the tach. pre-amp PWA P/N 4050783-XX. Install 1 each 68 MF capacitor, tantalum, 15V, 20%, Ampex P/N 037-957, across pins 3 and 2 on the board. The positive side is at pin 3. Next remove the display timer printed wiring assembly, P/N 4050810-XX and locate R4, R7 through R12. Replace these 47 ohm resistors with 7 each resistors. Comp. 120 ohm, 1/4 W, 10%, Ampex P/N 049-545. Re-assemble the tape timer assembly and mount the timer on the transport. Verify proper transport functions.

AMPEX

**PROFESSIONAL
AUDIO DIVISION**

FIELD ENGINEERING BULLETIN

REF. NO. 70186

MODEL MM-1200

PAGE 2 OF 2

SUPERSEDES

DATE OF ISSUE 10/76

TITLE: MM-1200 SEARCH TO CUE MULTIPLEX "BEAT"

V. PROCEDURE (CONTINUED)

If this problem existed prior to this modification, confirm that it no longer exists. This completes the modification.