

SM/23 Electronic Crossover

Schematic

B I A M P[®]
S Y S T E M S

10074 SW Arctic Drive Beaverton, OR 97005 503-641-7287

SM23-A CALIBRATION PROCEDURE

SIGNAL INPUT 0 dB UNBALANCED LOG Sweep

SIGNAL OUTPUT HF FOR METERING

1. LF LEVEL MAX

HF LEVEL MAX

FREQ CONTROL AT 500 HZ RANGE SWITCH X1

CENTER 5K & 1MEG TRIM POTS

ADJUST SLOPE CONTROL FOR UNIFORM FLATNESS OF FRONT
CORNER OF WAVEFORM (NOTE: IF LOG SWEEP IS NOT AVAILABLE
DON'T ATTEMPT THIS ADJUSTMENT.)

2. CHANGE FREQ CONTROL TO 1000 HZ

10 KHZ SINE WAVE INPUT

ADJUST THE HF OUTPUT LEVEL TO "0" DB.

3. 1 KHZ SINE WAVE INPUT

ADJUST 5K POT (1KHZ CAL) FOR -3dB DOWN (HF OUTPUT)

4. 100 HZ SINE WAVE INPUT - FREQ. POT TO 100N

ADJUST 1MEG POT (100 HZ CAL) FOR -3dB DOWN (HF OUT)

STEP 5.

MECHANICAL ADJUST FREQ POT FOR MECHANICAL CENTER

CHECK FREQ CALIBRATION AT 500 HZ (-3dB POINT)

± 50 HZ (450 - 550 HZ) 10% TOL

SIM 23 CALIBRATION PROCEDURE

VERY EARLY VERSION

SIGNAL INPUT Odd unbalanced (LOG SWEEP)

DEC 6, 1977

SIGNAL OUTPUT HF OUTPUT FOR METERING

STEP 1 LF LEVEL MAX * MECHANICAL CENTER SK
HF LEVEL MAX AND 1MEG TRIM POTS
FREQ. 1000 X 1 BEFORE CALIBRATING SLOPE CONTROL

Step 2.
Sine wave odd 10 KHZ

ADJUST OUTPUT for Odd.

STEP 3
FREQ GEN 1 KHZ

ADJUST SK POT FOR -3db down

STEP 4
FREQ GEN 100 HZ

* ADJUST 1MEG POT FOR -3db down

* FREQ CONTROL AT 100 (COUNTER CLOCKWISE)

STEP 5
MECHANICAL ADJUST FREQ POT

CHECK AT 500 HZ \pm 25 HZ (475 - 525)

5% TOL

FREQUENCY CONTROL

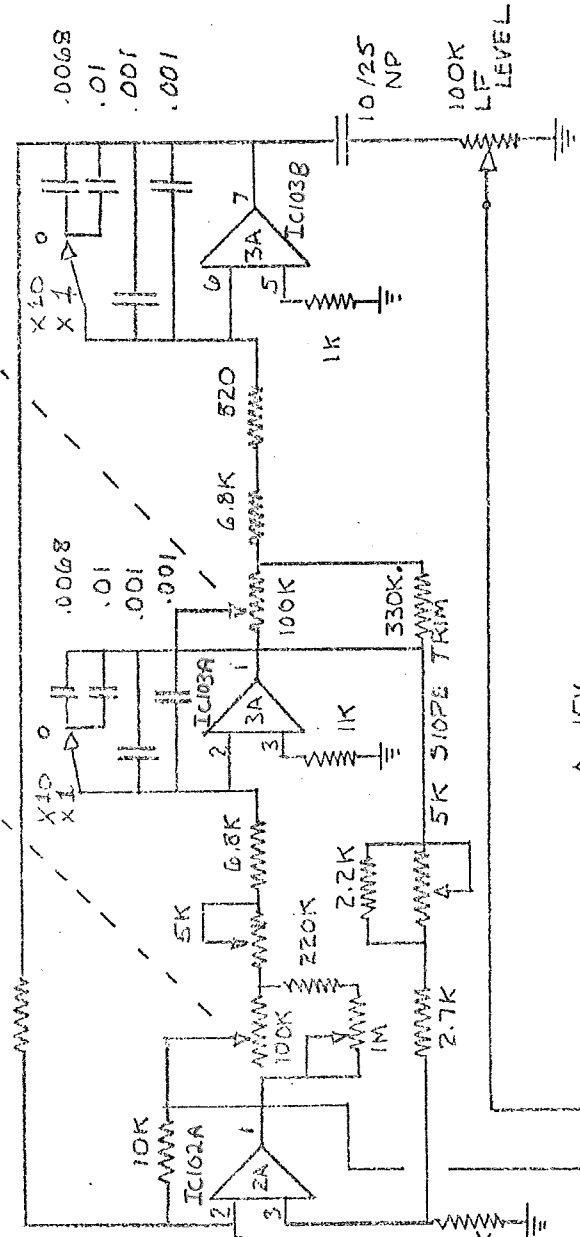

LF OUTPUTS

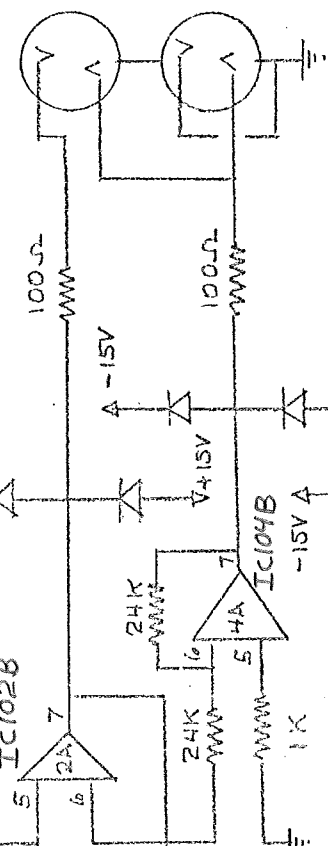

HF OUTPUTS

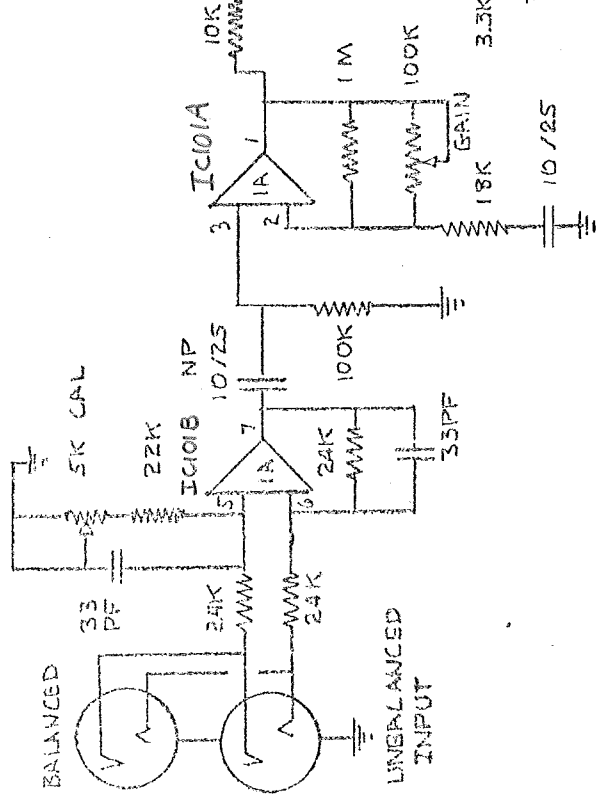
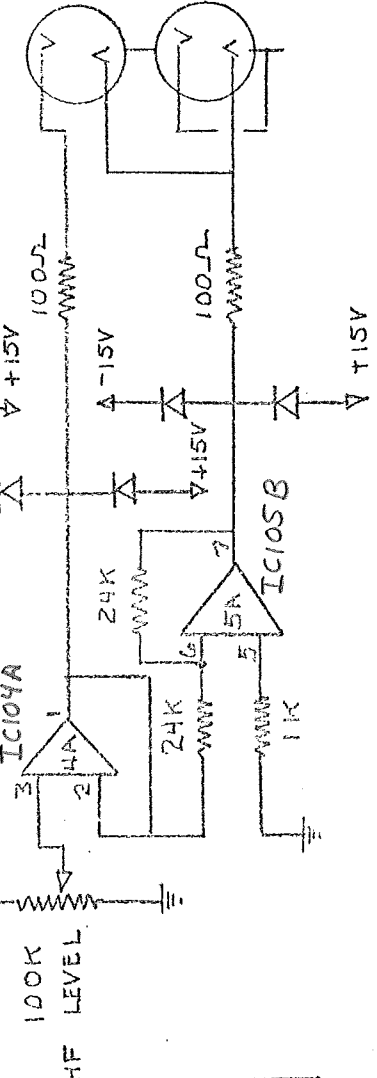

IC101

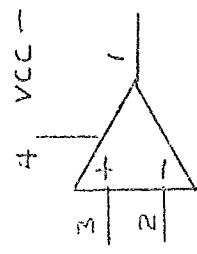

IC 4558

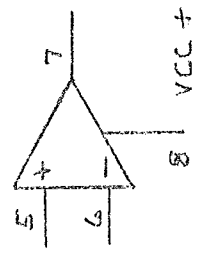

SM 23 (A) CHAN A
 ELECTRONIC CROSSOVER
 FEB 27 1978

STATE VARIABLE FILTER

GAIN

INPUT

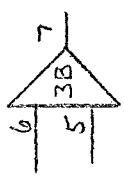

LF SECTION

HF SECTION

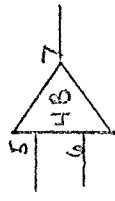
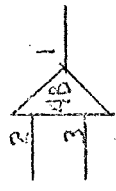

SM 23 (A) CHAN B
ELECTRONIC CROSSOVER
FEB 27. 1978

~~WAVY~~

1A

2A

~~WAVY~~

SLOPE CONTROL

HA

5A
2B

1B

4B

5B

~~WAVY~~
1KHZ COMMON MODE REJECTION

3A

~~WAVY~~
CAL 100HZ

~~WAVY~~
CAL 1KHZ

3B

~~WAVY~~
CAL 100HZ

~~WAVY~~
CAL 1KHZ

~~WAVY~~
SLOPE CONTROL

SM23 (A) IC LOCATION
ELECTRONIC CROSS OVER

FEB 27, 1978

SERVICE NOTICE



Biam Systems, Inc.

MAILING ADDRESS
P.O. Box 2160
Portland, OR 97208-2160
(Biam Systems, Inc.)

SM/23 - M2/V CROSSOVER OSCILLATION

WHEN COSMETICS AND ELECTRONICS WERE UPGRADED IN THE SM/23 AND M2/V CROSSOVERS THE 100ohm RESISTORS IN SERIES WITH THE OUTPUT CONTACTS WERE REPLACED WITH 100UF CAPACITORS. THE RESISTOR WAS REMOVED.

WE HAVE HAD SEVERAL COMPLAINTS OF THESE UNITS HUMMING OR OSCILLATING IN THE FIELD. TO CORRECT THE PROBLEM LIFT ONE END OF THE 100UF OUTPUT CAPACITOR AND ADD A 100ohm RESISTOR IN SERIES.

- 0 BLACK
- 1 BROWN
- 2 RED
- 3 ORANGE
- 4 YELLOW
- 5 GREEN
- 6 BLUE
- 7 VIOLET
- 8 GRAY
- 9 WHITE

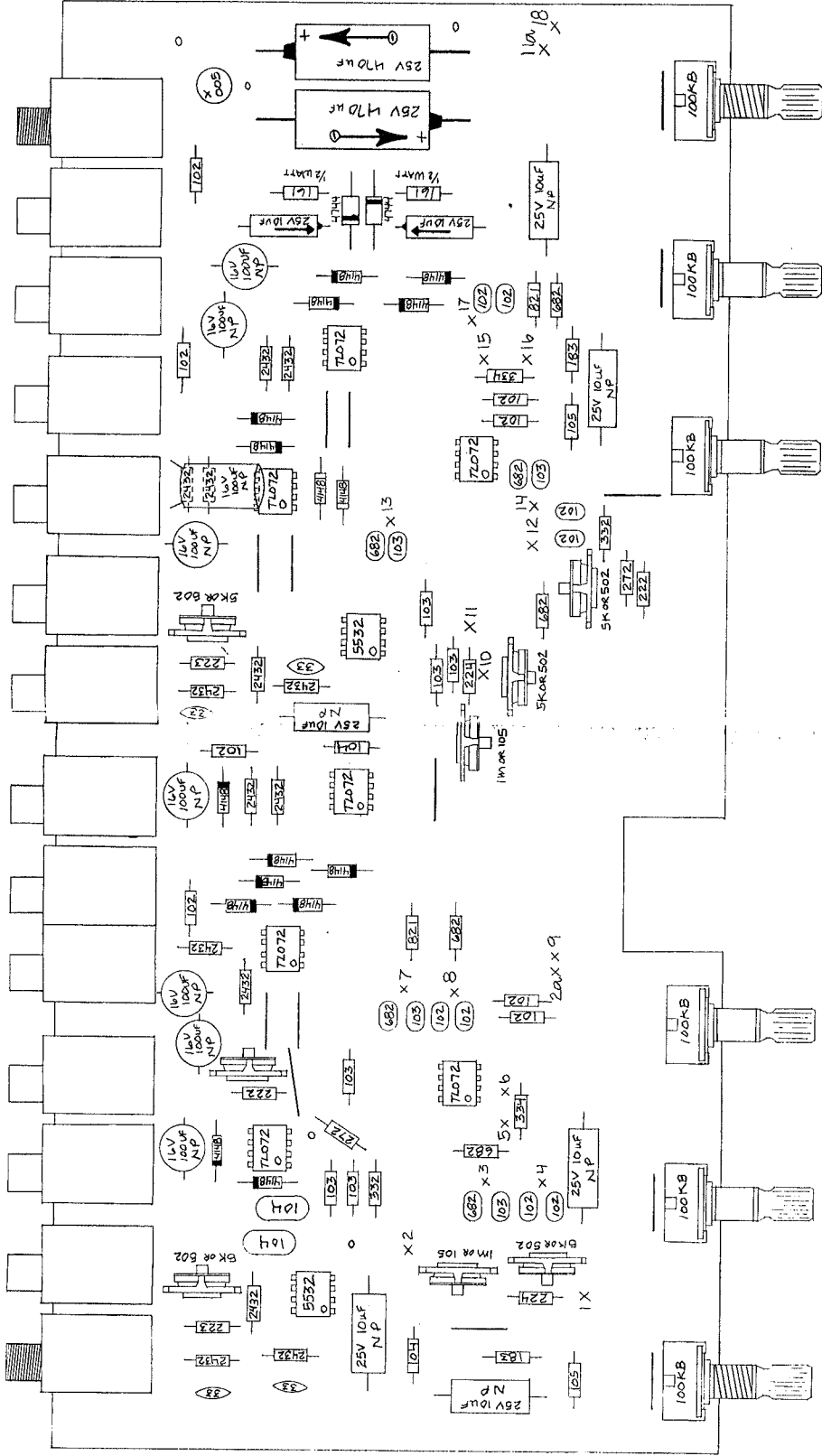

- X JUMPER PLACEMENT
- 13 BROWN 7 1/2
 - 14 VIOLET 8
 - 15 YELLOW 5
 - 16 RED 5
 - 17 BLUE 7 1/2
 - 18 WHITE 2 5/8

- 7 VIOLET 8
- 8 GREEN 4
- 9 WHITE 2 5/8
- 10 BLACK 8
- 11 GRAY 7 Jumps to 11a
- 12 GREEN 7 1/2

- 1 BLACK 8
- 2 BLACK 4 Jump to 2a
- 3 BLUE 7 1/2
- 4 BROWN 7 1/2
- 5 RED 5
- 6 YELLOW 5

FREQUENCY CONTROL

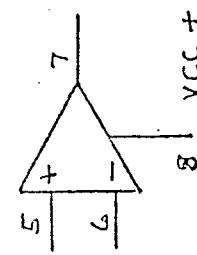
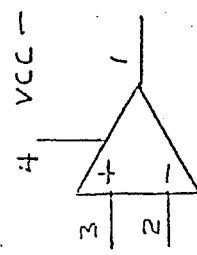
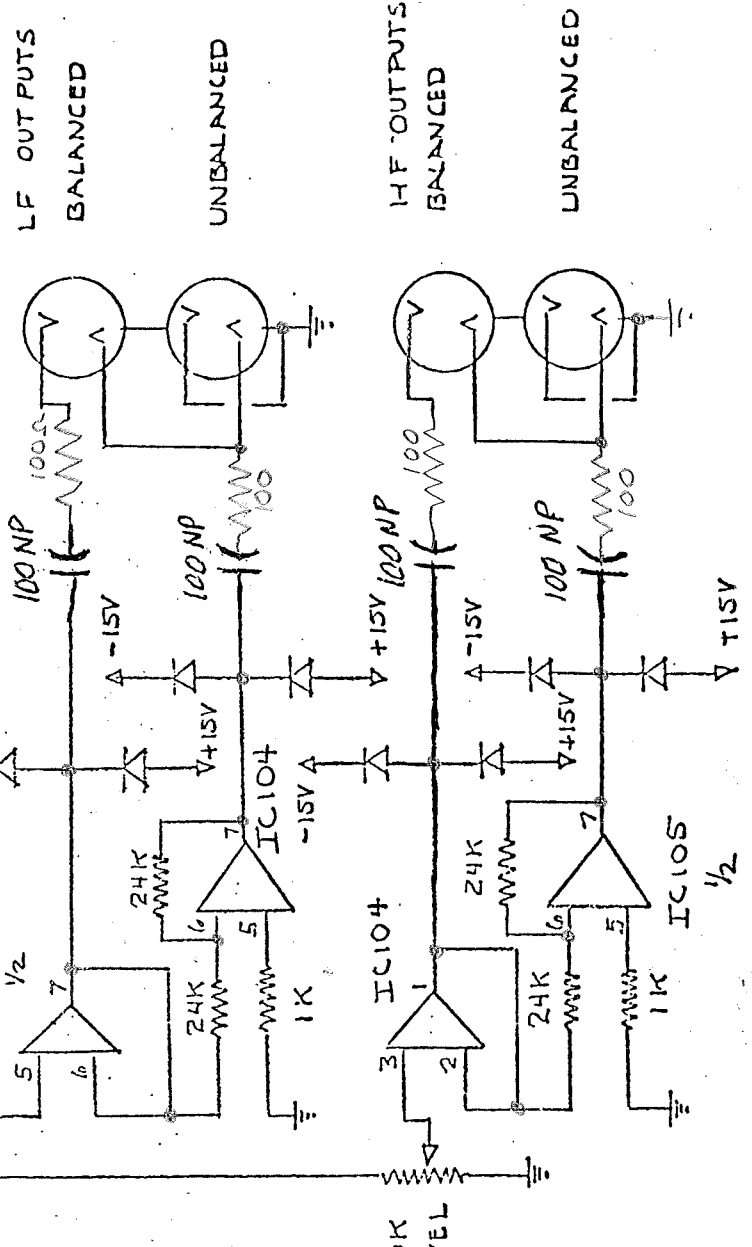
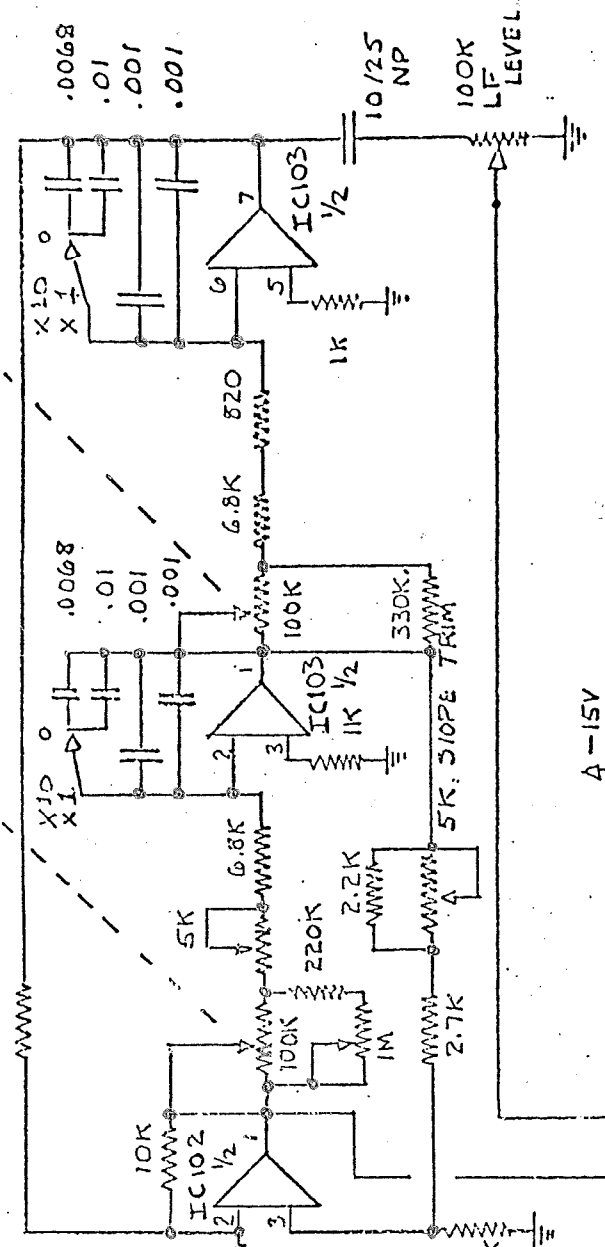

SM 23 CHAM A
 ELECTRONIC CROSSOVER
 1-21-82

FREQUENCY CONTROL

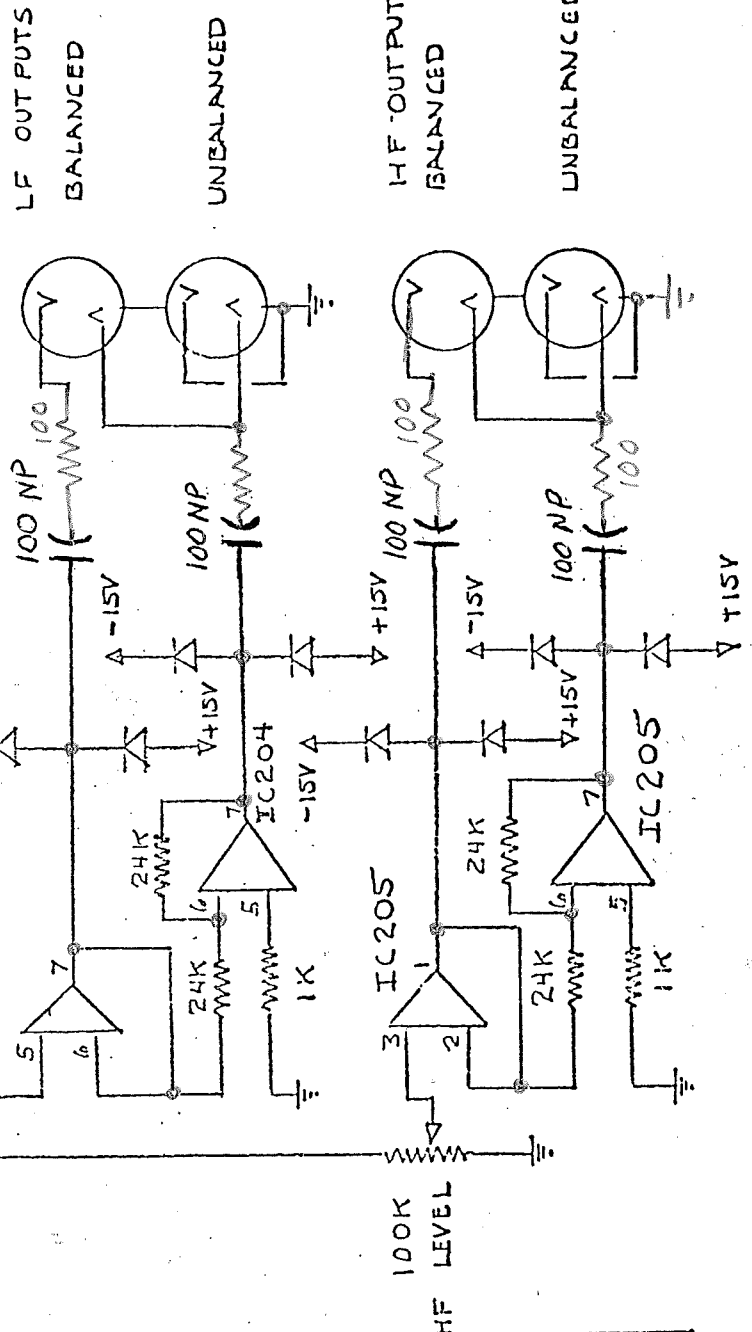
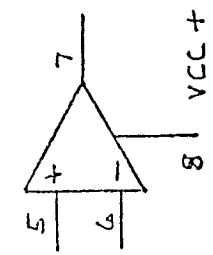
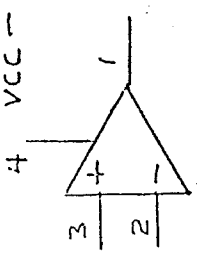
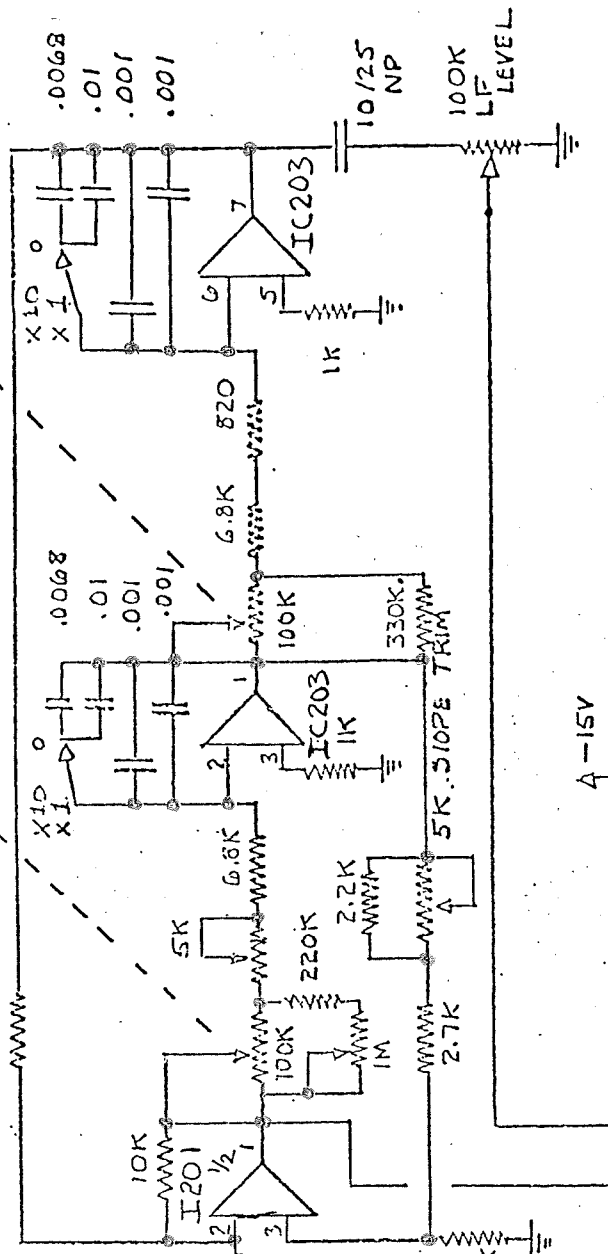

SIM 23 CHAN B
ELECTRONIC CROSSOVER
1-21-82

IC 101 = NE5532
 IC 102 = TL072
 IC 103 = TL072
 IC 104 = TL072
 IC 105 = TL072

OPAMP IC
CHANGES

IC 201 = NE5532
 IC 203 = TL072
 IC 204 = TL072
 IC 205 = TL072

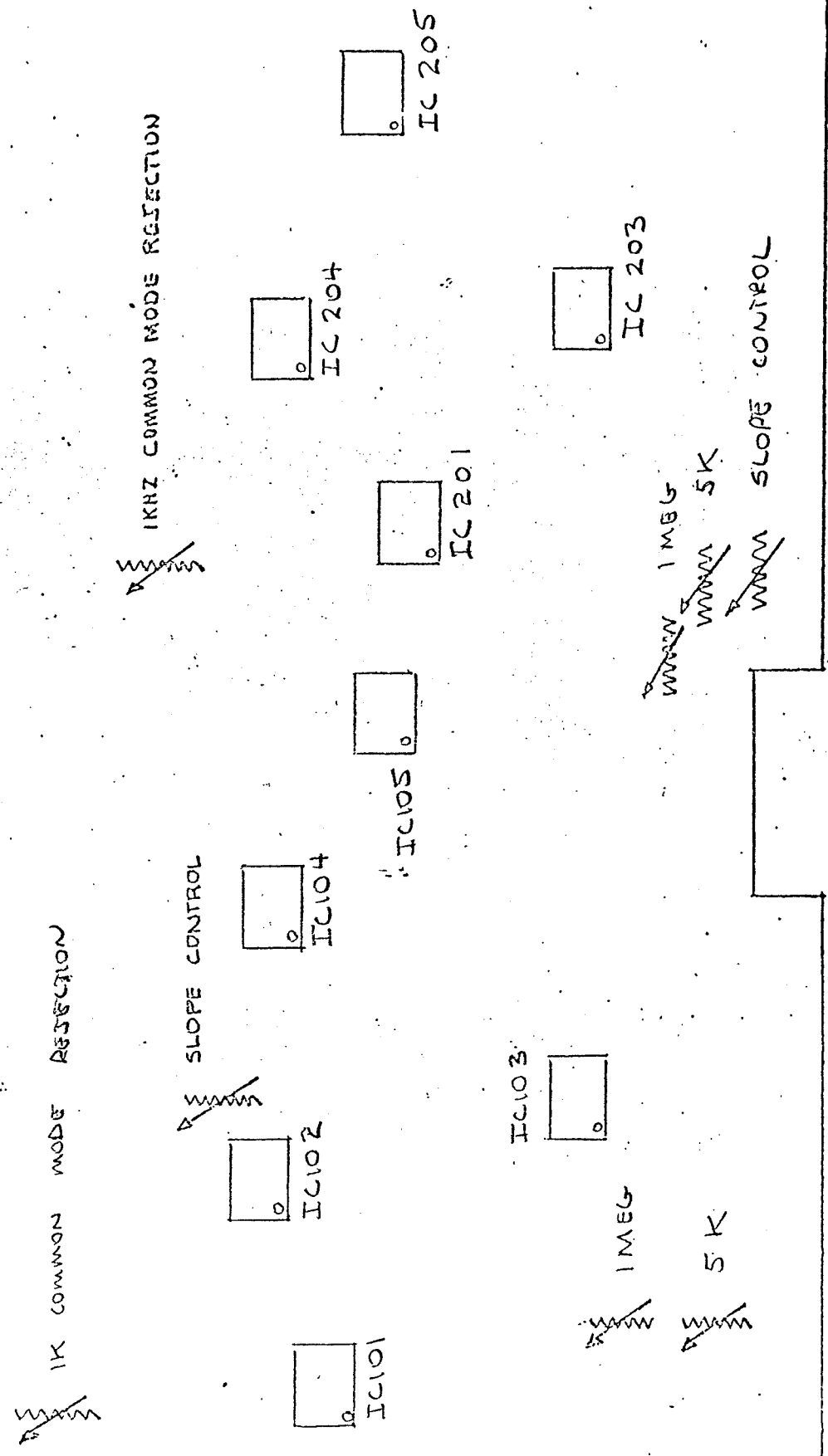

SM23 IC LOCATION
 ELECTRONIC CROSS OVER
 1-21-82

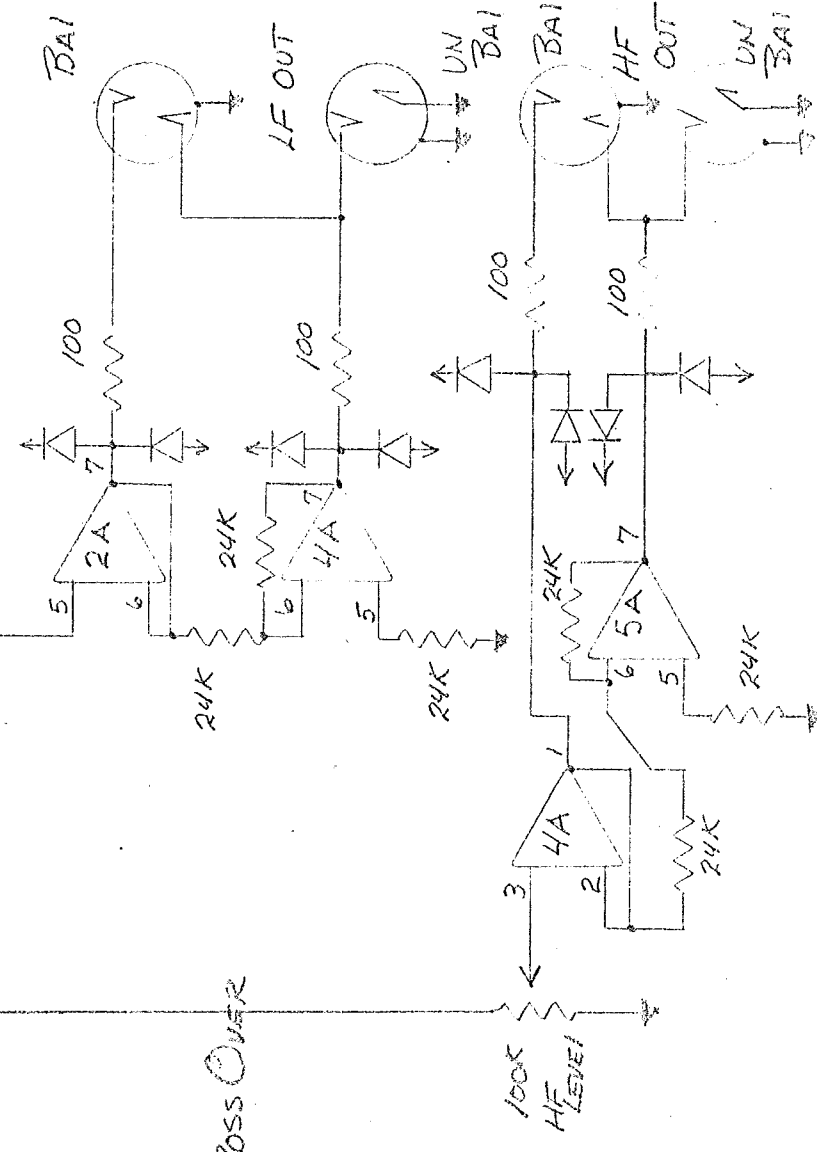
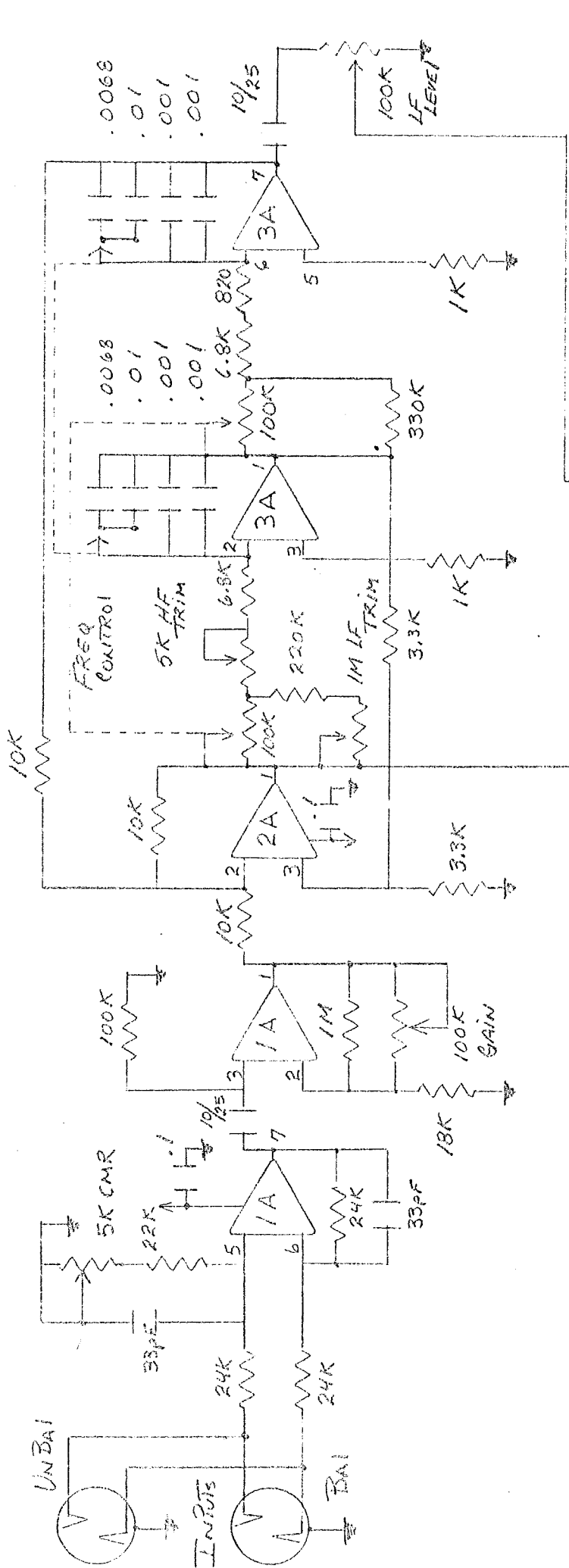

STEREO ELECTRONIC CROSS OVER
MODEL SM 23
CHANNEL A
(VERY EARLY)

STEREO ELECTRONIC CROSS OVER

MODEL SM 23

POWER SUPPLY

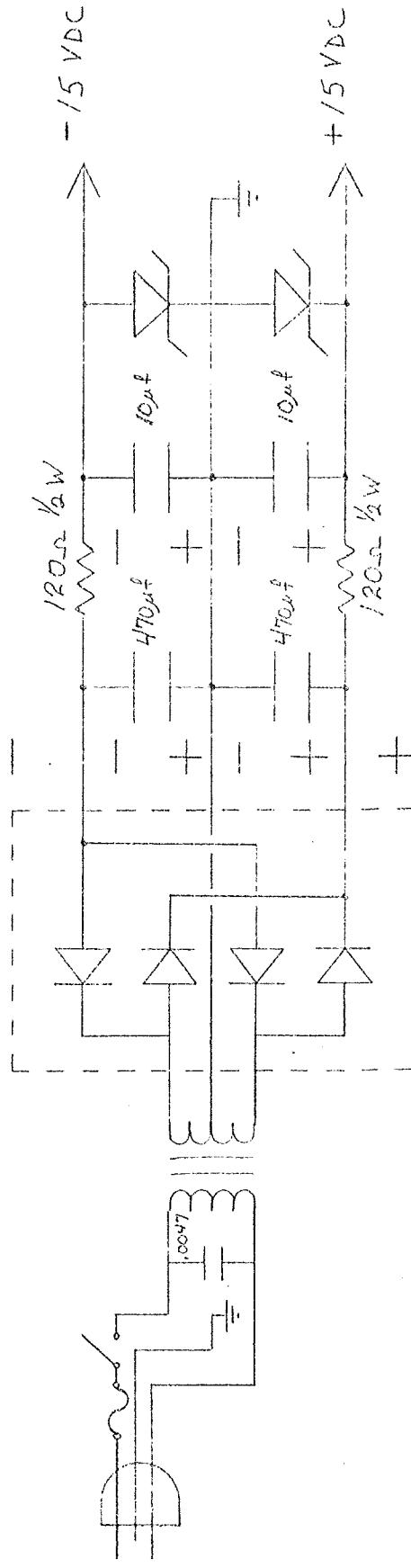

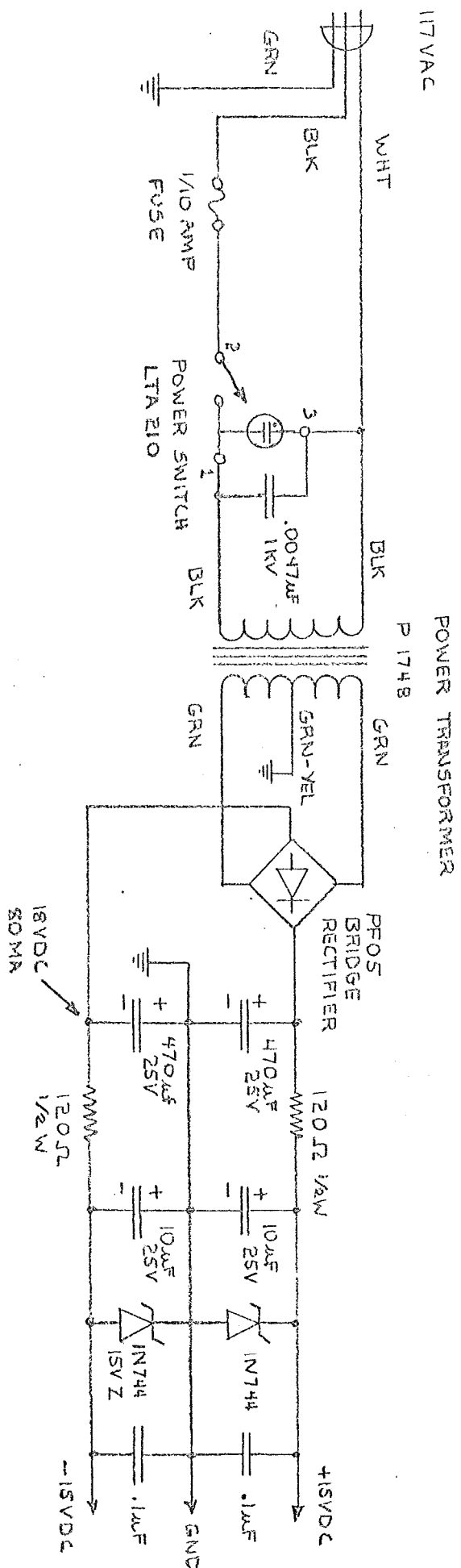

SM23 - B
 ELECTRONIC CROSSOVER
 POWER SUPPLY
 DRAWN BY J. DUNCAN
 APRIL 25, 1979