

OC-3

SUPER
Octave

SERVICE NOTES

Issued by RJA

TABLE OF CONTENTS

SPECIFICATIONS.....	2	PARTS LIST.....	6
LOCATION OF CONTROLS	4	TEST MODE.....	9
LOCATION OF CONTROLS PARTS LIST	4	CIRCUIT BOARD.....	13
EXPLODED VIEW	5	CIRCUIT DIAGRAM.....	14
EXPLODED VIEW PARTS LIST	5		

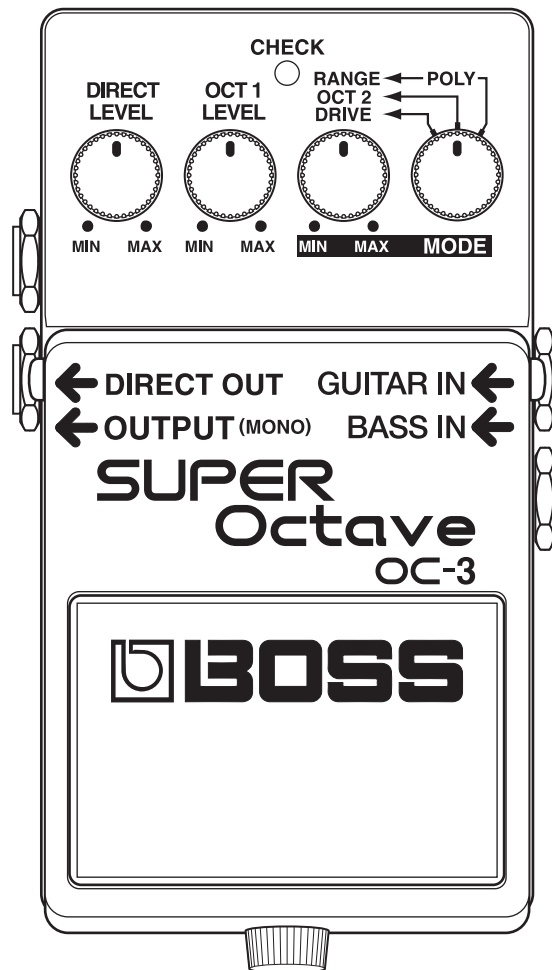

Copyright © 2003 ROLAND CORPORATION

All rights reserved. No part of this publication may be reproduced in any form without the written permission of ROLAND CORPORATION.

SPECIFICATIONS

OC-3: SUPER Octave

Nominal Input Level

-20 dBu

Input Impedance

1 M ohm

Nominal Output Level

-20 dBu

Output Impedance

1 k ohm

Recommended Load Impedance

10 k ohms or greater

Residual Noise

-96 dBu (IHF-A, Typ.); All knobs at center position

Controls

Pedal switch, DIRECT LEVEL knob, OCT 1 LEVEL knob, CONTROL knob, MODE knob,

Indicator

CHECK indicator (Serves also as battery check indicator)

Connectors

GUITAR IN jack, BASS IN jack, OUTPUT (MONO) jack, DIRECT OUT jack, AC adaptor jack (DC 9 V)

Power Supply

DC 9 V: Dry battery (9 V type) 6AM6/9 V (alkaline),
 Dry battery (9 V type) S-006P/9 V (6F22/9 V)
 AC Adaptor (PSA-series: optional)

Current Draw

50 mA (DC 9 V)

* *Expected battery life under continuous use:*

Carbon: 2 hours, Alkaline: 6 hours

These figures will vary depending on the actual conditions of use.

Dimensions

73 (W) x 129 (D) x 59 (H) mm

2-7/8 (W) x 5-1/8 (D) x 2-3/8 (H) inches

Weight

440 g / 1 lb (including battery)

Accessories

Owner's Manual ENGLISH: (#G6017375)

JAPANESE: (#G6017374)

Dry Battery: (#####) (9 V type) S-006P/9 V (6F22/9 V)

Options

AC Adaptor (PSA-series)

* $0\text{ dBu}=0.775\text{ Vrms}$

* *In the interest of product improvement, the specifications and/or appearance of this unit are subject to change without prior notice.*

LOCATION OF CONTROLS

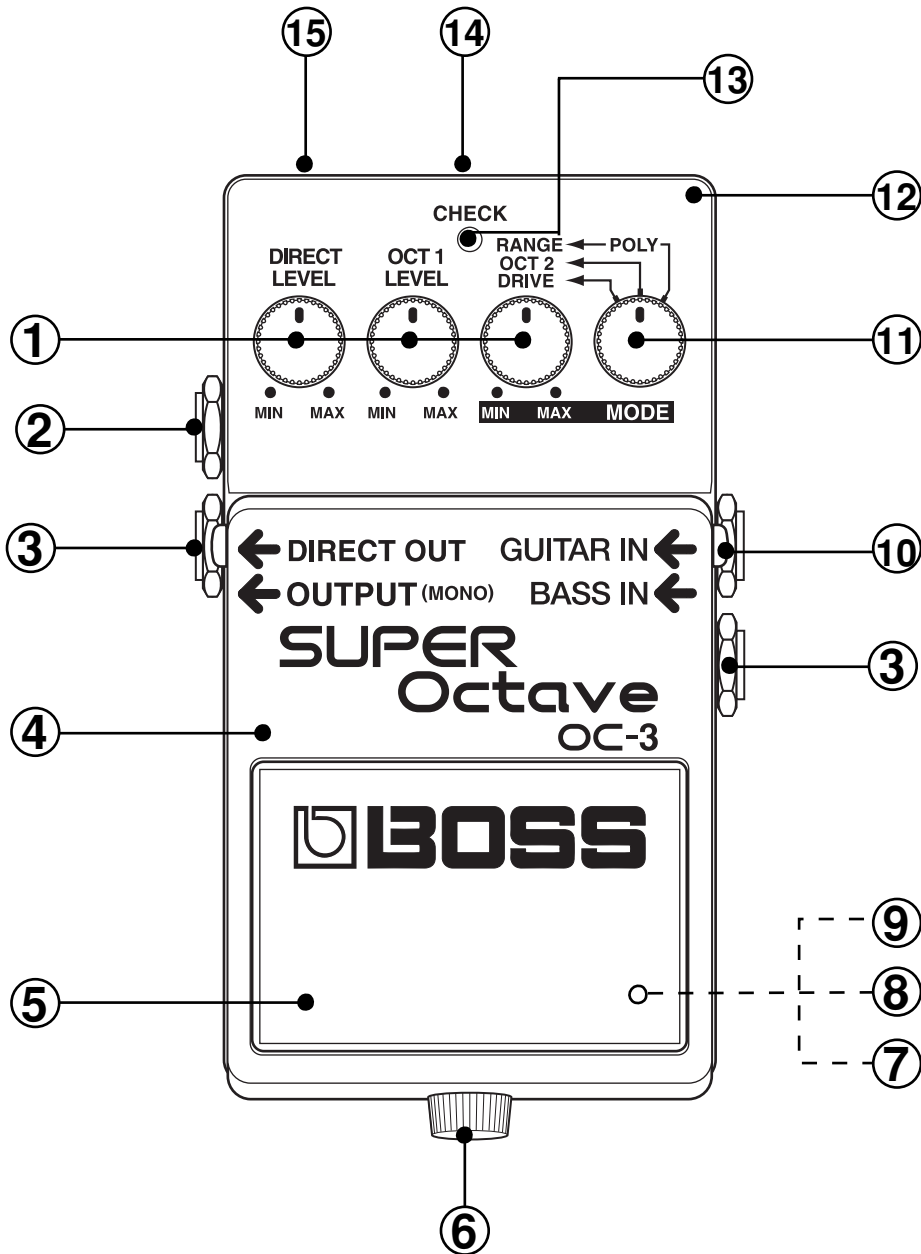

LOCATION OF CONTROLS PARTS LIST

NO	PART CODE	PART NAME	DESCRIPTION
1	22480260	P R-KNOB	MF BLK/LCG
	F3219113	POTENTIOMETER	RD901-20-15FW-B54-0039
2	13449150MF	JACK	HTJ-064-12D
3	13449140MF	JACK	HTJ-064-14D
4	75E072T000	PEDAL	
5	2235730400	FOOT BASE (PEDAL MAT)	
6	H5029820	THUMB SCREW	3X10mm (Black)
7	G253751603	BOTTOM CAUTION PSA	FCC/CE/C-TICK/EMC GRY
8	2235730500	BOTTOM BASE	
9	2202785100	BOTTOM COVER	
10	F3449150	JACK	2LJ-650NHW00
11	22480260	P R-KNOB	MF BLK/LCG
	F3219114	POTENTIOMETER	RD901-20-15FD-B54-0339
12	75E073C000	CASE	
13	1502928100	LED (RED)	L-34HD5L
14	13449717	AC ADAPTOR JACK	HEC2392-01-150
15	2253753801	PSA CAUTION	

EXPLODED VIEW

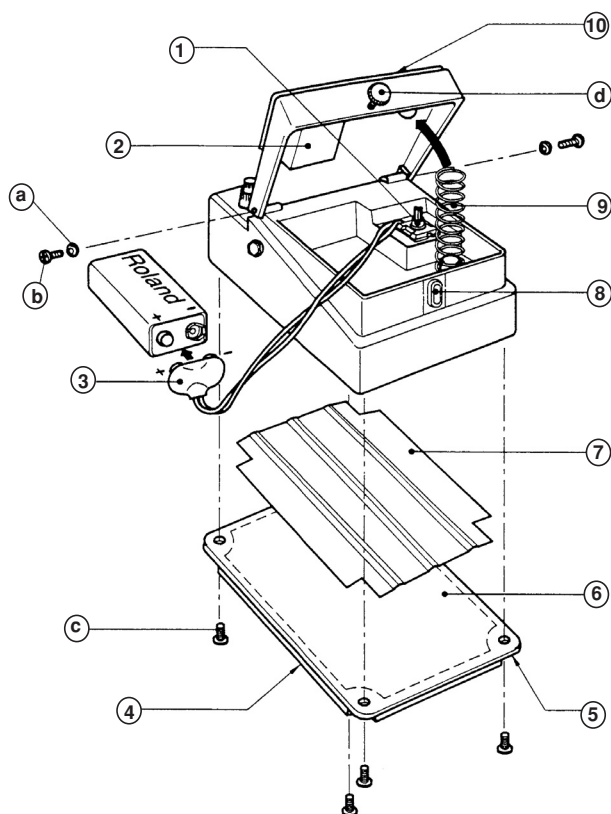

EXPLODED VIEW PARTS LIST

[PARTS]

NO	PART CODE	PART NAME	DESCRIPTION	Q'TY
1	13129710	SWITCH (PUSH)	JM-0404	1
2	2226733300	CUSHION		1
3	F3419102	BATTERY CONNECTOR		1
4	G253751603	BOTTOM CAUTION PSA	FCC/CE/C-TICK/EMC GRY	1
5	2235730500	BOTTOM BASE		1
6	2202785100	BOTTOM COVER		1
7	G2167301	INSULATION SPACER		1
8	2215770201	PEDAL GUIDE BUSH		1
9	2217710900	COIL SPRING		1
10	2235730400	FOOT BASE (PEDAL MAT)		1

[SCREW]

NO	PART CODE	PART NAME	DESCRIPTION	Q'TY
a	H5039401	NYLON WASHER M3X6X0.5		2
b	H501941301	SCREW M3X10	BINDING MACHINE FEBC	2
c	H5029325	SCREW M3X6	PAN HEAD TAPTITE B1 FEBC	4
d	H5029820	SCREW M3X10	THUMB SCREW	1

PARTS LIST

SAFETY PRECAUTIONS:

The parts marked \triangle have safety-related characteristics. Use only listed parts for replacement.

CONSIDERATION ON PARTS ORDRING

When ordering any parts listed in the parts list, please specify the following items in the order sheet.

	QTY	PART NUMBER	DESCRIPTION	MODEL NUMBER
Ex.	10	22575241	Sharp Key	C-20/50
	15	2247017300	Knob (orange)	DAC-15D

Failure to completely fill the above items with correct number and description will result in delayed or even undelivered replacement.

NOTE: The parts marked # are new. (initial parts)

CASING					Q'TY
	2235730400	FOOT BASE (PEDAL MAT)	235-304		1
	2202785100	BOTTOM COVER	202-851		1
	2235730500	BOTTOM BASE	235-305		1
#	75E073C000	CASE			1
#	75E072T000	PEDAL			1
KNOB,BUTTON					
	22480260	MF BLK/LCG	P R-KNOB		4
SWITCH					
	13129710	JM-0404	SWITCH (PUSH)	SW1	1
JACK,EXT TERMINAL					
	13449150MF	HTJ-064-12D	PHONE JACK (STEREO)	JK2	1
	F3449150	2LJ-650NHW00	JACK (STEREO+SW)	JK6	1
	13449140MF	HTJ-064-14D	JACK (STEREO)	JK5,JK7	2
	13449717	HEC2392-01-150	ADAPTOR JACK	JK1	1
PWB ASSY					
#	75E073O000	OUT JACK ASSY	OUTPUT (MONO)		1
#	75E073I000	IN JACK ASSY	GUITAR IN + BASS IN		1
#	703433L000	LED BOARD ASSY			1
#	75E073P000	MAIN BOARD ASSY			1
IC					
	02897778	S-80130ALMC-JAP-T2	IC (RESET)	IC9	1
	F5289101	NJM2100M 8P SOP	IC (OP.AMP)	IC2	1
	02565501	TC220CCA0AF-B01 (MR3)	IC (DSP)	IC7	1
	F5179125	S-8520E33MC-BJS-T2	IC (DC-DC)	IC6	1
#	03349278	UPD780034AGK-B10-9ET V1.00	IC (CPU)	IC5	1
	15189261	M5218AFP-600E	IC (BIPOLAR OP AMP)	IC1,IC3,IC4	3
	02451434	AK4552VT	IC (AD/DA)	IC8	1
TRANSISTOR					
	15309104	2SA1586-GR (TE85R)	TRANSISTOR	Q13	1
	15319107	2SC4116-GR (TE85R)	TRANSISTOR	Q1,Q8,Q9,Q10,Q11,Q12	6
	15329103	2SK880GR-TE85R	FET TRANSISTOR	Q3	1
	F5329502	2SJ190	FET	Q15	1
	F5329530	2SK879Y	FET	Q4,Q5,Q6,Q7	4
DIODE					
	1502928100	L-34HDSL	LED (RED)	LED1	1
	15339119	1SS-352	DIODE	D4,D5,D6,D7	4
	F5339201	GS1G	DIODE	D2	1
	F5339137	SS14 VF=0.45V	DIODE	D1,D3	2
RESISTOR					
#	F5399104	10 J	MTL.FILM RESISTOR	R22	1
#	F5399170	100K J	MTL.FILM RESISTOR	R33,R39,R46,R50,R54,R58,R73,R77	8
#	F5399140	10K J	MTL.FILM RESISTOR	R2,R3,R12,R14,R20,R21,R76,R90,R92	9
#	F5399147	15K J	MTL.FILM RESISTOR	R11,R23,R27	3
#	F5399128	1K J	MTL.FILM RESISTOR	R34,R40,R67,R74,R88	5
#	F5399200	1M J	MTL.FILM RESISTOR	R13,R26,R30,R35,R41,R43,R47,R51,R55,R79	10
#	F5399130	2.2K J	MTL.FILM RESISTOR	R1	1

RESISTOR					
#	F5399152	22K J	MTL.FILM RESISTOR	R7,R8,R10,R15,R16,R24,R28,R31,R32,R36,R37, R38,R42,R61,R62,R65,R81,R82	18
#	F5399154	27K J	MTL.FILM RESISTOR	R89	1
#	F5399156	33K J	MTL.FILM RESISTOR	R64	1
#	F5399298	4.7 J	MTL.FILM RESISTOR	R100	1
#	F5399106	47 J	MTL.FILM RESISTOR	R78	1
#	F5399160	56K J	MTL.FILM RESISTOR	R9,R25,R29,R44,R45,R48,R49,R52,R53,R56, R57,R63	12
	F5429365	10K OHM F RANK (1%)	CHIP RESISTOR	R91	1
	F5429386	150K F (1608TYPE)	CHIP RESISTOR	R19	1
POTENTIOMETER					
#	F3219113	RD901-20-15FW-B54-0039	POTENTIOMETER NON CLICK	VR1,VR2,VR3	3
#	F3219114	RD901-20-15FD-B54-0339	POTENTIOMETER 3CLICK	VR4	1
CAPACITOR					
	01906178	ECPU1C104MA5 (SUBMICRON)	MYLAR CAPACITOR	C13	1
	F5359732	GRM39B102J50PT	CERAMIC CAPACITOR	C78	1
	F5359740	GRM39B222K50PT	CERAMIC CAPACITOR	C11,C34,C38	3
	F5359370	GRM39CH180J50PT	CERAMIC CAPACITOR	C73	1
	F5359704	GRM39CH220J50PT	CERAMIC CAPACITOR	C62,C63,C72	3
	F5359800	GRM39F104Z25PT	CERAMIC CAPACITOR	C2,C20,C24,C26,C28,C31,C47,C48,C49,C50, C55,C56,C57,C58,C61,C65,C66,C67,C68,C69, C74,C75,C77,C79	24
#	F3629695KM	1/50V	CHEMICAL CAPACITOR	C23	1
	F3629705	10/16V SV P=1.5 4X5	CHEMICAL CAPACITOR	C10,C19,C41,C44,C80,C81	6
	F3629700	10U/16V (H=7MM)	CHEMICAL CAPACITOR	C14,C21,C22,C25,C33,C36,C37,C40,C43	9
#	F3629680	47/16V	CHEMICAL CAPACITOR	C3,C5,C27,C60	4
#	F5359725	ECJ1VC1H151J 150P J	CERAMIC CAPACITOR	C12,C35,C39,C42,C45	5
#	F5359817	GRM39B683K50PT 0.068 K	CERAMIC CAPACITOR	C71	1
	13629550KM	100/16V	CHEMICAL CAPACITOR	C1,C4,C46,C76	4
INDUCTOR,COIL,FILTER					
	F2449210	SLF7032T-4R7M1R7-2 (4.7UH)	SMD COIL	L2	1
	F5409131	QT04-60	EMI	L1	1
	F2449209	SLF7032T-151MR29-2 (150UH)	COIL	L3	1
CRYSTAL,RESONATOR					
	F5299307	HC-49SM 11.2896MHZ	CRYSTAL	X2	1
	F5299114	HC-49SM 5MHZ	CRYSTAL	X1	1
WIRING,CABLE					
	G3477166	FLAT CABLE	7P-100X6X6 P=2.0	CN2,CN5	1
SCREWS					
	H5029820	SCREW M3X10	THUMB SCREW		1
	H5029325	SCREW 3X6	PAN HEAD TAPTITE-2 BC		5
	H5039205	WASHER 12.5X9.5X0.5/0.9	INTERNAL TOOTH FENI		4
	H5039510	NUT M9X12X2	FENI		4
	H501941301	SCREW 3X10MM	BINDING MACHINE FEBC		2
	H5039104	JACK WASHER M9.2X14X1.6	AL		1
	22137709	JACK SPACER M9.6X14X1.0			1
	H5039401	NYLON WASHER 3X6X0.5			2
	H5039521	VR ACCESSORY NUT M7			4
	H5039112	WASHER M9			4
PACKING					
	G2627738	INNER BOX			1
#	G2607111	PACKING CASE			1
MISCELLANEOUS					
	G253751603	BOTTOM CAUTION PSA	FCC/CE/C-TICK/EMC GRY		1
#	F2557302	INSULATING SHEET	DIRECT OUT		1
	H5319102	INSULOK TIE	80M/M T-18S		2
	2253753801	PSA CAUTION	253-538		1
	2226733300	CUSHION	226-333		1
	2217710900	COIL SPRING	217-109		1
	2215770201	PEDAL GUIDE BUSH	215-702		1
	F3419102	BATTERY CONNECTOR	(006P)		1
	22257257	EARTH TERMINAL		ET1,ET2	2
	G2167301	INSULATION SPACER			1
	H2369402	POLYCA PIPE M3X6X6			1

ACCESSORIES (Standard)

#	*****	BATTERY	MANGANESE	1
#	G6017374	OWNER'S MANUAL	JAPANESE	1
#	G6017375	OWNER'S MANUAL	ENGLISH	1

TEST MODE

Required Items

Tools Required

- Oscillator
- Oscilloscope
- Noise meter
- 47 k Ω short plug (#17041375)

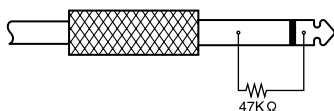

- Monitor Speakers

1. Test Categories

1. DSP, CPU Check
2. DIRECT LEVEL Volume Check
3. OCT1 LEVEL Volume Check
4. CONTROL (RANGE, OCT2, DRIVE) Volume Check
5. AF/AD Check
6. DAC, JACK Switch Check
7. MUTE Check
8. MODE Volume Check
9. DSP THRU MAXIMUM Output Check
10. BYPASS MAXIMUM Output Check
11. Battery Check
12. Noise Check

2. Entering Test Mode

- Turn all volume controls down completely (to minimum). Set MODE to DRIVE.
- Hold down the pedal and connect the DC plug to adapter jack.
- When CHECK lights up, release the pedal.
- The CHECK light goes off for approximately two seconds, then lights again, indicating that the unit has entered test mode.

NOTE

The unit will not switch to test mode unless all volume controls are turned completely down. Furthermore, the unit will not enter test mode if, due to faulty volume controls or other cause, the minimum value is not detected for all volume controls.

NOTE

If CHECK does not light, it may be due to a faulty LED. Switch the pedal on and off in Normal mode to confirm that CHECK lights and goes off. If CHECK flashes, refer to "1. DSP, CPU Check" in "3. Tests."

NOTE

For instructions on skipping tests in order to perform only a particular test item, refer to "5. Instructions for Performing Only Desired Tests" following the detailed descriptions of the test items.

3. Tests

1. DSP, CPU Check

- Refer to "2. Entering Test Mode" and switch to Test mode.
- A check of the DSP and CPU is performed automatically while the CHECK light is off. If no problem is detected, CHECK lights up and the unit enters Test mode; CHECK flashes if an error has occurred.
- Connect the oscillator to GUITAR IN or BASS IN and input a rectangular wave (200 Hz, 100 mVp-p) and check the waveform output with the oscilloscope from both OUTPUT (MONO) and DIRECT OUT. Confirm that the waveform output is the same 200 Hz, 100 mVp-p waveform shown in the figure (DSP THRU).

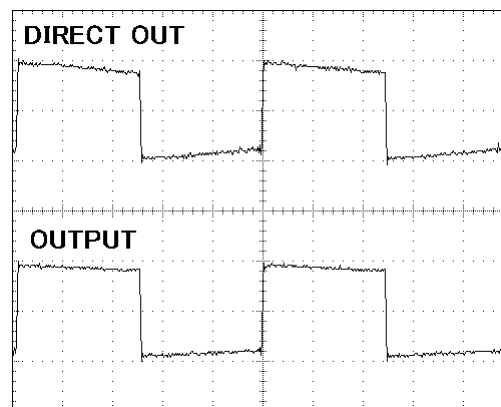

50mV/DIV, 1mS/DIV

- If CHECK lights up, the process automatically advances to the next step.

NOTE

If CHECK flashes, it may be due to a fault surrounding the DSP or CPU, faulty soldering, or other such problems. Disconnect the DC plug from the adapter jack and turn off the power.

2. DIRECT LEVEL Volume Check

- Rotate the knob in the clockwise direction from minimum to center, then to maximum; CHECK should change from lit to off to lit.
- When the maximum is detected, CHECK lights up, and then the process advances to the OCT1 LEVEL Volume Check.

3. OCT1 LEVEL Volume Check

- Rotate the knob in the clockwise direction from minimum to center, then to maximum; CHECK should change from lit to off to lit.
- When the maximum is detected, CHECK lights up, and then the process advances to the CONTROL (RANGE, OCT2, DRIVE) Volume Check.

NOTE

The maximum values for the OCT1 LEVEL Volume Check and DIRECT LEVEL VOLUME are detected simultaneously. The OCT1 LEVEL Volume Check is not run unless the DIRECT LEVEL Volume maximum is detected.

4. CONTROL (RANGE, OCT2, DRIVE) Volume Check

- Rotate the knob in the clockwise direction from minimum to center, then to maximum; CHECK should change from lit to off to lit.
- When the maximum is detected, CHECK lights up, and then the process advances to the AF/AD Check.

NOTE

The maximum values for the CONTROL Volume Check and the OCT1 LEVEL Volume are detected simultaneously. The CONTROL Volume Check is not run unless the OCT1 LEVEL Volume maximum is detected.

5. AF/AD Check

- Confirm that the MODE control is set to DRIVE.
- Use the oscillator to input a sine wave at 200 Hz, -25 dBm (FLAT) to GUITAR IN or BASS IN.
- Check the waveform output with the oscilloscope from both OUTPUT (MONO) and DIRECT OUT. Confirm that the waveform is the same as that shown in the figure and that there is no distortion.

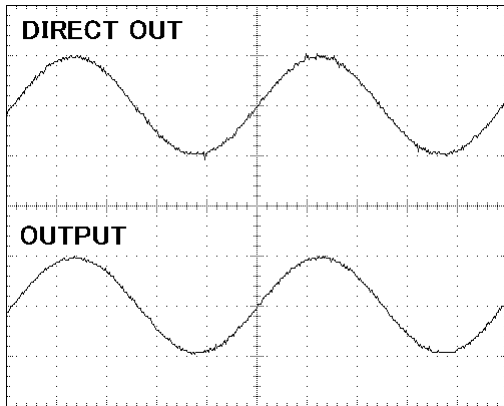

50mV/DIV, 1mS/DIV

- Check the waveform output with the noise meter from both OUTPUT (MONO) and DIRECT OUT. Confirm that each waveform output is FLAT and between -28.5 dBm and -25.5 dBm.

6. DAC, JACK Switch Check

- Confirm that the MODE control is set to OCT2. CHECK goes off.
- Use the oscillator to input a sine wave at 200 Hz, -25 dBm (FLAT) to GUITAR IN.
- Connect plugs to both the OUTPUT (MONO) and DIRECT OUT jacks, and check the waveform output from both jacks with the oscilloscope. Confirm that the waveform output from DIRECT OUT is a 200 Hz rectangular wave, the waveform output from OUTPUT (MONO) is a 200 Hz sine wave, and that the waveform is the same as that shown in the figure.

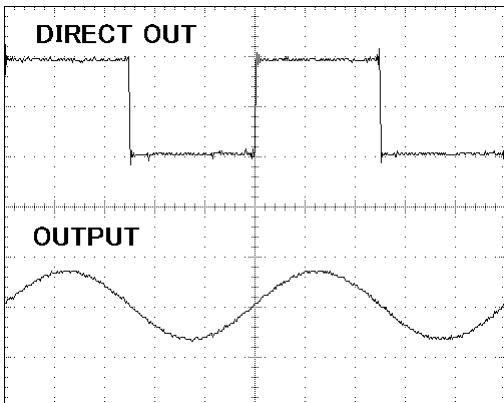

50mV/DIV, 1mS/DIV

- Disconnect the plug connected to the DIRECT OUT jack.
- Confirm that the waveform output from OUTPUT (MONO) is a 200 Hz rectangular wave, and that the waveform is the same as that shown in the figure.

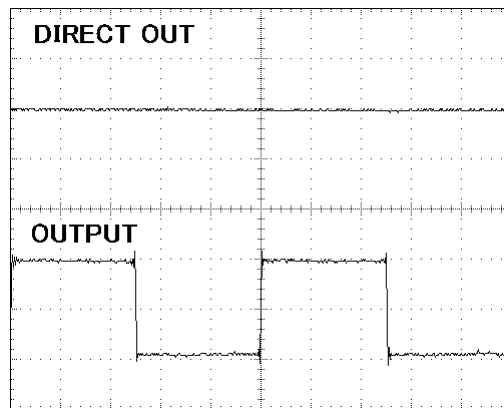

50mV/DIV, 1mS/DIV

- Disconnect the plug connected to the GUITAR IN jack and connect it to BASS IN. Confirm that the waveform output from OUTPUT (MONO) is a 400 Hz rectangular wave, and that the waveform is the same as that shown in the figure.

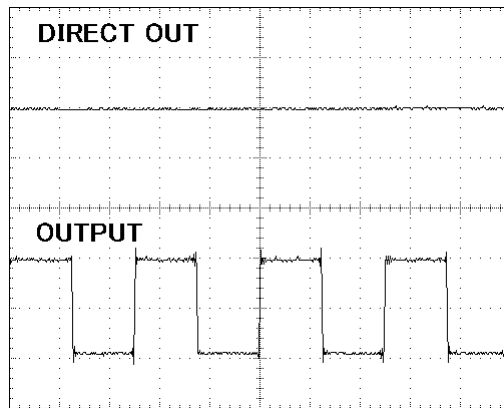

50mV/DIV, 1mS/DIV

- Connect the plug to the DIRECT OUT jack.

Confirm that the waveform output from DIRECT OUT is a 400 Hz rectangular wave, the waveform output from OUTPUT (MONO) is a 200 Hz sine wave, and that the waveform is the same as that shown in the figure.

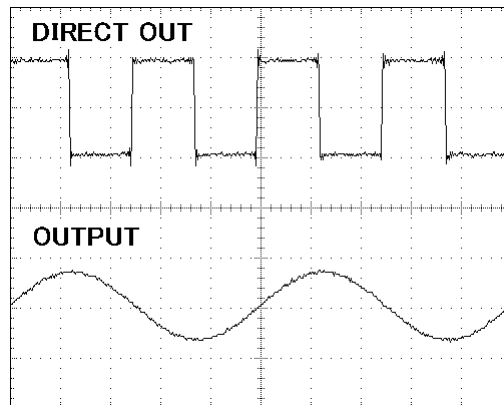

50mV/DIV, 1mS/DIV

7. MUTE Check

- Confirm that the MODE control is set to POLY. CHECK lights up.
- Use the oscillator to input a sine wave at 200 Hz, +5 dBm (FLAT) to GUITAR IN or BASS IN.
- Check the waveform output from both OUTPUT (MONO) and DIRECT OUT with the oscilloscope. Confirm that the waveform is the same as that shown in the figure.

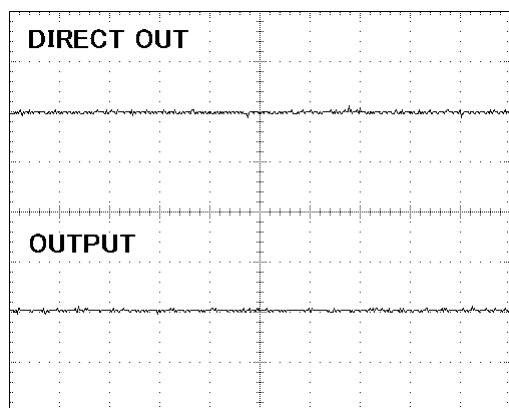

1V/DIV, 1mS/DIV

- Check the output level from both OUTPUT (MONO) and DIRECT OUT with the noise meter. Confirm that each waveform output is FLAT and at or below -74 dBm.

8. MODE Volume Check

- Confirm that CHECK lights up when the MODE control is set to POLY.
- Set the MODE control is to OCT2. Confirm that CHECK goes off.
- Set the MODE control is to DRIVE. Confirm that CHECK lights up.



Rotate the knob slowly and firmly.

9. DSP THRU MAXIMUM Output Check

- Confirm that the MODE control is set to DRIVE.
- Use the oscillator to input a sine wave at 200 Hz, +5 dBm (FLAT) to GUITAR IN or BASS IN.
- Check the waveform output from both OUTPUT (MONO) and DIRECT OUT with the oscilloscope. Confirm that the waveform is the same as that shown in the figure and that there is no distortion.

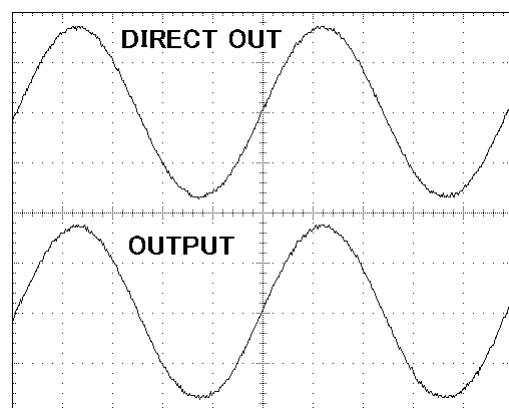

1V/DIV, 1mS/DIV

- Check the output level from both OUTPUT (MONO) and DIRECT OUT with the noise meter. Confirm that each is FLAT and between +3 dBm and +6 dBm.

10. BYPASS MAXIMUM Output Check

- Press the pedal.
- Confirm that CHECK goes off and then comes on again (exiting Test mode).
- Press the pedal again, and confirm that CHECK goes off (so that the effects are switched off).
- Use the oscillator to input a sine wave at 200 Hz, +5 dBm (FLAT) to GUITAR IN or BASS IN.
- Connect plugs to both the OUTPUT (MONO) and DIRECT OUT jacks, and check the waveform output from both jacks with the oscilloscope. Confirm that the waveform is the same as that shown in the figure, with no waveform output from OUTPUT (MONO) and no distortion in the waveform output from DIRECT OUT.

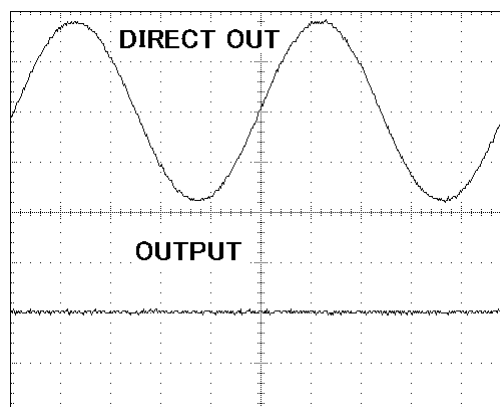

1V/DIV, 1mS/DIV

- Check the output level from both OUTPUT (MONO) and DIRECT OUT with the noise meter. Confirm that the DIRECT OUT output level is FLAT and between +3 dBm and +6 dBm, and that the OUTPUT (MONO) output is FLAT and at or below -80 dBm.
- Disconnect the plug connected to the DIRECT OUT jack.
- Check the waveform output from OUTPUT (MONO) with the oscilloscope. Confirm that the waveform is the same as that shown in the figure and that there is no distortion in the waveform.

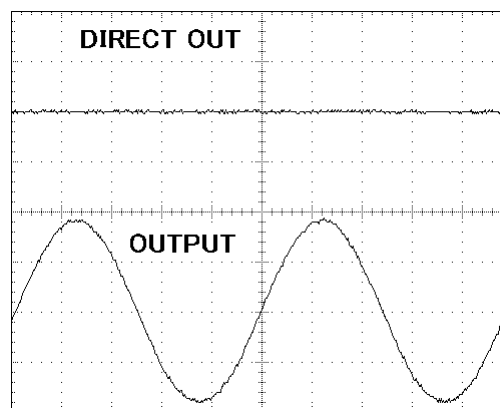

1V/DIV, 1mS/DIV

- Check the OUTPUT (MONO) output level with the noise meter. Confirm that the output level is FLAT and between +3 dBm and +6 dBm.

11. Battery Check

- Press the pedal and confirm that CHECK lights up (so that the effects are switched on).
- Confirm that a plug is connected to either the GUITAR IN jack or BASS IN jack.
- Disconnect the DC plug from the adapter jack.
- Confirm that CHECK is lit.



If CHECK is dimmer than when used with the adapter, it indicates that the batteries are going dead.

12. Noise Check

- Connect the DC plug to the adapter jack.



As this checks places a drain on the batteries, use the adapter when performing this check.

- Confirm that CHECK is lit and that the effects are on.
- Turn all volume controls to maximum. Set the MODE to POLY.
- Connect the short plug (47 k ohm) at "GUITAR IN JACK".
- Connect plugs to both the OUTPUT (MONO) and DIRECT OUT jacks and check the residual noise from both jacks with the noise meter. Confirm that both are JIS-A, at or below -92 dBm.
- Press the pedal so that CHECK goes off, switching off the effects.
- Check the residual noise from DIRECT OUT with the noise meter. Confirm JIS-A at or below -98 dBm at.
- Connect the monitor speakers to DIRECT OUT.
- Shock-test the unit by dropping it from a height of 10 cm twice. Confirm that the unit produces no unusual noise.
- Switch the pedal between ON and OFF, and confirm that no switching noise is produced.
- Switch CHECK so that it is unlit and the effects are switched off.
- Disconnect the plug connected to the DIRECT OUT jack.
- Check the residual noise from OUTPUT (MONO) with the noise meter. Confirm JIS-A, at or below -98 dBm.
- Connect the monitor speakers to OUTPUT (MONO).
- Shock-test the unit by dropping it from a height of 10 cm twice. Confirm that the unit produces no unusual noise.
- Switch the pedal between ON and OFF, and confirm that no switching noise is produced.
- Switch on the CHECK light so that the effects are switched on.
- Rotate each knob to confirm that the unit produces no unusual noise.

4. Exiting Test Mode

- The pedal can be pressed to exit Test mode.



"10. BYPASS MAXIMUM Output Check," "11. Battery Check," and "12. Noise Check" are performed in Normal mode, and are not checked as part of the test items.

5. Instructions for Performing Only Desired Tests

- Refer to "2. Entering Test Mode" to switch to Test mode.
- The "DSP, CPU Check" is run automatically when the pedal is released, and CHECK lights up if there are no errors.
- Rotate the MODE control to the desired test category.

DRIVE: Volume checks, DSP THRU Maximum Output Level.

OCT2: DAC, Jack Switch Check

POLY: MUTE Check, MODE Volume Check



The Volume checks cannot be run in the following sequence: DIRECT LEVEL, OCT1 LEVEL, CONTROL.



The AF/AD Check is not selectable. It may be run after the Volume checks.

In addition, the DSP THRU Maximum Output Level cannot be run immediately following the Volume checks. Run the test after switching the MODE control back to DRIVE.



To run "10. BYPASS MAXIMUM Output Check," "11. Battery Check," or "12. Noise Check," turn on the power and perform them in Normal mode, without switching to Test mode.

6. Precautions

Run all checks following repairs or servicing.

